

CHAPTER

53

FUSELAGE



**757-200
STRUCTURAL REPAIR MANUAL**

**CHAPTER 53
FUSELAGE**

Subject/Page	Date	Subject/Page	Date	Subject/Page	Date
EFFECTIVE PAGES		53-00-01 REPAIR 1		53-00-01 REPAIR 8	
1 thru 13	May 20/2009	201	Jan 20/2005	201	Jan 20/2005
14	BLANK	202	Jan 20/2005	202	Jan 20/2005
53-CONTENTS		53-00-01 REPAIR 2		203 Jan 20/2005	
1	Jan 20/2005	201	Jan 20/2005	204	May 20/2008
2	Sep 20/2007	202	Jan 20/2005	205	Jan 20/2005
3	Sep 20/2007	203	Jan 20/2005	206	Jan 20/2005
4	Sep 20/2007	204	Jan 20/2005	53-00-01 REPAIR 9	
5	Sep 20/2007	205	Jan 20/2005	201	Feb 20/2005
6	Sep 20/2007	206	Jan 20/2005	202	Jan 20/2005
7	Sep 20/2007	53-00-01 REPAIR 3		203	Jan 20/2005
8	Sep 20/2007	201	Jan 20/2005	204	Jan 20/2005
9	Sep 20/2007	202	Jan 20/2005	205	Jan 20/2005
10	Sep 20/2007	203	Jan 20/2005	206	Jan 20/2005
11	Sep 20/2007	204	Jan 20/2005	53-00-01 REPAIR 10	
12	Sep 20/2007	205	Jan 20/2005	201	Jan 20/2005
13	May 20/2008	206	Jan 20/2005	202	Feb 20/2005
14	May 20/2008	53-00-01 REPAIR 4		203	Jan 20/2005
53-00-00 GENERAL		201	Jan 20/2005	204	Jan 20/2005
1	Jan 20/2006	202	Jan 20/2005	205	Jan 20/2005
2	Sep 20/2008	203	Jan 20/2005	206	Jan 20/2005
3	May 20/2005	204	Jan 20/2005	53-00-01 REPAIR 11	
4	May 20/2005	53-00-01 REPAIR 5		201	Feb 20/2005
5	May 20/2005	201	Jan 20/2005	202	Jan 20/2005
6	Sep 20/2007	202	Jan 20/2005	203	Jan 20/2005
53-00-01 ALLOWABLE DAMAGE 1		203	Jan 20/2005	204	Jan 20/2005
101	May 20/2006	204	Jan 20/2005	205	Jan 20/2005
102	May 20/2006	53-00-01 REPAIR 6		206	Jan 20/2005
103	May 20/2006	201	Jan 20/2005	53-00-01 REPAIR 12	
104	May 20/2006	202	Jan 20/2005	201	Jan 20/2005
105	May 20/2006	203	Jan 20/2005	202	Jan 20/2005
106	May 20/2006	204	Jan 20/2005	203	Jan 20/2005
53-00-01 ALLOWABLE DAMAGE 2		205	Jan 20/2005	204	Jan 20/2005
101	Jan 20/2005	206	Jan 20/2005	205	Jan 20/2005
102	Jan 20/2005	207	Jan 20/2005	206	Jan 20/2005
53-00-01 REPAIR GENERAL		208	Jan 20/2005	207	Jan 20/2005
201	Jan 20/2005	53-00-01 REPAIR 7		208	BLANK
202	Jan 20/2005	201	Jan 20/2005	53-00-01 REPAIR 13	
203	Jan 20/2005	202	Jan 20/2005	201	Jan 20/2005
204	Jan 20/2005			202	Jan 20/2005

A = Added, R = Revised, O = Overflow, D = Deleted

53-EFFECTIVE PAGES



**757-200
STRUCTURAL REPAIR MANUAL**

**CHAPTER 53
FUSELAGE**

Subject/Page	Date	Subject/Page	Date	Subject/Page	Date
53-00-01 REPAIR 13 (cont)		53-00-03 REPAIR 1 (cont)		53-00-07 REPAIR 2 (cont)	
203	Jan 20/2005	204	Jan 20/2005	203	Jan 20/2005
204	Jan 20/2005	205	Jan 20/2005	204	BLANK
205	Jan 20/2005	206	Jan 20/2005	53-00-07 REPAIR 3	
206	Jan 20/2005	207	Jan 20/2005	201	Jan 20/2005
53-00-01 REPAIR 14		208	Jan 20/2005	202	Jan 20/2005
201	Jan 20/2005	209	Jan 20/2005	203	Jan 20/2005
202	Jan 20/2005	210	BLANK	204	BLANK
203	Jan 20/2005	53-00-03 REPAIR 2		53-00-07 REPAIR 4	
204	Jan 20/2005	201	Jan 20/2005	201	Jan 20/2005
205	Jan 20/2005	202	Jan 20/2005	202	Jan 20/2005
206	Jan 20/2005	203	Jan 20/2005	203	Jan 20/2005
53-00-01 REPAIR 15		204	Jan 20/2005	204	BLANK
201	Jan 20/2005	205	Jan 20/2005	53-00-07 REPAIR 5	
202	Jan 20/2005	206	Jan 20/2005	201	Sep 20/2007
203	Jan 20/2005	207	Jan 20/2005	202	Sep 20/2007
204	Jan 20/2005	208	Jan 20/2005	203	Sep 20/2007
205	Jan 20/2005	53-00-04 ALLOWABLE DAMAGE 1		204	Sep 20/2007
206	Jan 20/2005	101	Jan 20/2005	205	Sep 20/2007
53-00-01 REPAIR 16		102	Jan 20/2005	206	Sep 20/2007
201	Jan 20/2005	103	Jan 20/2005	207	Sep 20/2007
202	Jan 20/2005	104	BLANK	208	Sep 20/2007
203	Jan 20/2005	53-00-07 ALLOWABLE DAMAGE 1		209	Sep 20/2007
204	Jan 20/2005	101	Jan 20/2005	210	Sep 20/2007
205	Jan 20/2005	102	Jan 20/2005	211	Sep 20/2007
206	Jan 20/2005	103	Jan 20/2005	212	Sep 20/2007
53-00-01 REPAIR 17		104	Jan 20/2005	213	Sep 20/2007
201	Jan 20/2005	53-00-07 ALLOWABLE DAMAGE 2		214	Sep 20/2007
202	Jan 20/2005	101	Jan 20/2005	215	Sep 20/2007
203	Jan 20/2005	102	Jan 20/2005	216	BLANK
204	Jan 20/2005	103	Jan 20/2005	53-00-50 IDENTIFICATION 1	
205	Jan 20/2005	104	Jan 20/2005	1	Jan 20/2005
206	Jan 20/2005	53-00-07 REPAIR 1		2	Jan 20/2005
53-00-03 ALLOWABLE DAMAGE 1		201	Jan 20/2005	3	Jan 20/2005
101	Jan 20/2005	202	Jan 20/2005	4	Jan 20/2005
102	Jan 20/2005	203	Jan 20/2005	5	Jan 20/2005
53-00-03 REPAIR 1		204	BLANK	6	BLANK
201	Jan 20/2005	53-00-07 REPAIR 2		53-00-50 ALLOWABLE DAMAGE 1	
202	Jan 20/2005	201	Jan 20/2005	101	Jan 20/2005
203	Jan 20/2005	202	Jan 20/2005	102	Jan 20/2005

A = Added, R = Revised, O = Overflow, D = Deleted

53-EFFECTIVE PAGES



**757-200
STRUCTURAL REPAIR MANUAL**

**CHAPTER 53
FUSELAGE**

Subject/Page	Date	Subject/Page	Date	Subject/Page	Date
53-00-50 ALLOWABLE DAMAGE 2		53-00-51 REPAIR 3		53-00-52 REPAIR 4	
101	Jan 20/2005	201	Jan 20/2005	201	Jan 20/2005
102	Jan 20/2005	202	Jan 20/2005	202	Jan 20/2005
53-00-50 REPAIR 1		203	Jan 20/2005	203	Jan 20/2005
201	Jan 20/2005	204	Jan 20/2005	204	Jan 20/2005
202	Sep 20/2007	205	May 20/2006	53-00-53 ALLOWABLE DAMAGE 1	
203	May 20/2006	206	BLANK	101	Jan 20/2005
204	Sep 20/2007	53-00-51 REPAIR 4		102	Jan 20/2005
205	May 20/2006	201	Jan 20/2005	103	Jan 20/2005
206	May 20/2006	202	Jan 20/2005	104	Jan 20/2005
207	May 20/2006	53-00-51 REPAIR 5		105	Jan 20/2005
208	Jan 20/2005	201	Jan 20/2005	106	BLANK
209	Jan 20/2005	202	Jan 20/2005	53-00-70 ALLOWABLE DAMAGE 1	
210	Jan 20/2005	203	Jan 20/2005	101	Jan 20/2005
211	Jan 20/2005	204	Jan 20/2005	102	Jan 20/2005
212	Jan 20/2005	53-00-52 ALLOWABLE DAMAGE 1		103	Jan 20/2005
213	Jan 20/2005	101	Jan 20/2005	104	Jan 20/2005
214	Jan 20/2005	102	Jan 20/2005	105	Jan 20/2005
215	Jan 20/2005	103	Jan 20/2005	106	BLANK
216	Jan 20/2005	104	Jan 20/2005	53-00-70 REPAIR 1	
217	Jan 20/2005	105	Jan 20/2005	201	Jan 20/2005
218	Jan 20/2005	106	Jan 20/2005	202	Jan 20/2005
53-00-51 ALLOWABLE DAMAGE 1		53-00-52 REPAIR 1		203	Jan 20/2005
101	Jan 20/2005	201	Jan 20/2005	204	Jan 20/2005
102	Jan 20/2005	202	Jan 20/2005	205	Jan 20/2005
103	Jan 20/2005	203	Jan 20/2005	206	Jan 20/2005
104	BLANK	204	Jan 20/2005	207	Jan 20/2005
53-00-51 REPAIR 1		205	Jan 20/2005	208	Jan 20/2005
201	Jan 20/2005	206	BLANK	209	Jan 20/2005
202	Jan 20/2005	53-00-52 REPAIR 2		210	Jan 20/2005
203	Jan 20/2005	201	Jan 20/2005	211	Jan 20/2005
204	Jan 20/2005	202	BLANK	212	Jan 20/2005
205	Jan 20/2005	53-00-52 REPAIR 3		53-00-71 ALLOWABLE DAMAGE 1	
206	BLANK	201	Jan 20/2005	101	Jan 20/2005
53-00-51 REPAIR 2		202	Jan 20/2005	102	Jan 20/2005
201	Jan 20/2005	203	Jan 20/2005	103	Jan 20/2005
202	Jan 20/2005	204	Jan 20/2005	104	Jan 20/2005
203	Jan 20/2005	205	Jan 20/2005	105	Jan 20/2005
204	BLANK	206	Jan 20/2005	106	Jan 20/2005
				107	Jan 20/2005

A = Added, R = Revised, O = Overflow, D = Deleted

53-EFFECTIVE PAGES



**757-200
STRUCTURAL REPAIR MANUAL**

**CHAPTER 53
FUSELAGE**

Subject/Page	Date	Subject/Page	Date	Subject/Page	Date
53-00-71 ALLOWABLE DAMAGE 1 (cont)		53-10-04 IDENTIFICATION 1 (cont)		53-10-08 IDENTIFICATION 1 (cont)	
108	Jan 20/2005	2	Jan 20/2005	4	Jan 20/2005
109	Jan 20/2005	3	Jan 20/2005	5	Jan 20/2005
110	Jan 20/2005	4	Jan 20/2005	6	Jan 20/2005
53-10-01 IDENTIFICATION 1		5	Jan 20/2005	7	Jan 20/2005
1	Jan 20/2005	6	BLANK	8	Jan 20/2005
2	Jan 20/2005	53-10-04 ALLOWABLE DAMAGE GENERAL		9	Jan 20/2005
3	Jan 20/2005	101	Jan 20/2005	10	Jan 20/2005
4	BLANK	102	Jan 20/2005	11	Jan 20/2005
53-10-01 IDENTIFICATION 2		103	Jan 20/2005	12	Jan 20/2005
1	Jan 20/2005	104	BLANK	53-10-08 ALLOWABLE DAMAGE 1	
2	Jan 20/2005	53-10-04 REPAIR GENERAL		101	Jan 20/2007
53-10-01 ALLOWABLE DAMAGE GENERAL		201	Jan 20/2005	102	Jan 20/2005
101	Jan 20/2007	202	Jan 20/2005	103	Jan 20/2005
102	BLANK	203	Jan 20/2005	104	Jan 20/2005
53-10-01 REPAIR GENERAL		204	BLANK	105	Jan 20/2005
201	Jan 20/2005	53-10-07 IDENTIFICATION 1		106	Jan 20/2005
202	BLANK	1	Jan 20/2005	107	Jan 20/2005
53-10-01 REPAIR 1		2	Jan 20/2005	108	Jan 20/2005
201	Jan 20/2005	3	Jan 20/2005	109	Jan 20/2005
202	Jan 20/2005	4	Jan 20/2005	110	Jan 20/2005
203	Jan 20/2005	5	Jan 20/2005	53-10-13 IDENTIFICATION 1	
204	BLANK	6	Jan 20/2005	1	Jan 20/2005
53-10-03 IDENTIFICATION 1		7	Jan 20/2005	2	Jan 20/2005
1	Jan 20/2005	8	Jan 20/2005	3	Jan 20/2005
2	Jan 20/2005	9	Jan 20/2005	4	Jan 20/2005
3	Jan 20/2005	10	Jan 20/2005	5	Jan 20/2005
4	Jan 20/2005	11	Jan 20/2005	6	BLANK
5	Jan 20/2005	12	BLANK	53-10-14 IDENTIFICATION 1	
6	BLANK	53-10-07 ALLOWABLE DAMAGE GENERAL		1	Jan 20/2005
53-10-03 ALLOWABLE DAMAGE GENERAL		101	Jan 20/2005	2	Jan 20/2005
101	Jan 20/2005	102	BLANK	3	Jan 20/2005
102	BLANK	53-10-07 REPAIR GENERAL		4	Jan 20/2005
53-10-03 REPAIR GENERAL		201	Jan 20/2005	5	Jan 20/2005
201	Jan 20/2005	202	BLANK	6	BLANK
202	BLANK	53-10-08 IDENTIFICATION 1		53-10-14 ALLOWABLE DAMAGE 1	
53-10-04 IDENTIFICATION 1		1	Jan 20/2005	101	Jan 20/2005
1	Jan 20/2005	2	Jan 20/2005	102	Jan 20/2005
		3	Jan 20/2005	103	Jan 20/2005
				104	Jan 20/2005

A = Added, R = Revised, O = Overflow, D = Deleted

53-EFFECTIVE PAGES



**757-200
STRUCTURAL REPAIR MANUAL**

**CHAPTER 53
FUSELAGE**

Subject/Page	Date	Subject/Page	Date	Subject/Page	Date
53-10-14 ALLOWABLE DAMAGE 1 (cont)		53-10-51 IDENTIFICATION 1 (cont)		53-10-72 REPAIR GENERAL	
105	Jan 20/2005	5	Jan 20/2005	201	Jan 20/2006
106	BLANK	6	Jan 20/2005	202	Sep 20/2006
53-10-14 REPAIR GENERAL		53-10-51 ALLOWABLE DAMAGE GENERAL		203	Sep 20/2007
201	Jan 20/2005	101	Jan 20/2007	204	Sep 20/2007
202	BLANK	102	BLANK	205	Sep 20/2007
53-10-15 IDENTIFICATION 1		53-10-51 REPAIR GENERAL		206	May 20/2006
1	Jan 20/2005	201	Jan 20/2005	207	May 20/2006
2	Jan 20/2005	202	BLANK	208	Sep 20/2007
3	Jan 20/2005	53-10-51 REPAIR 1		209	Sep 20/2007
4	Jan 20/2005	201	Jan 20/2005	210	May 20/2006
5	Jan 20/2005	202	Jan 20/2005	211	Sep 20/2007
6	BLANK	203	Jan 20/2005	212	Sep 20/2007
53-10-15 ALLOWABLE DAMAGE 1		204	Jan 20/2005	213	Sep 20/2007
101	Jan 20/2005	205	Jan 20/2005	214	Jan 20/2005
102	Jan 20/2005	206	Jan 20/2005	215	Jan 20/2005
103	Jan 20/2005	207	Jan 20/2005	216	Jan 20/2005
104	Jan 20/2005	208	BLANK	217	Jan 20/2005
105	Jan 20/2005	53-10-52 IDENTIFICATION 1		218	Jan 20/2005
106	BLANK	1	Jan 20/2005	219	Jan 20/2005
53-10-15 REPAIR GENERAL		2	Jan 20/2005	220	BLANK
201	Jan 20/2005	3	Jan 20/2005	53-10-90 IDENTIFICATION 1	
202	Jan 20/2005	4	Jan 20/2005	1	Jan 20/2005
203	Jan 20/2005	53-10-52 ALLOWABLE DAMAGE GENERAL		2	BLANK
204	BLANK	101	Jan 20/2007	53-10-90 ALLOWABLE DAMAGE 1	
53-10-50 IDENTIFICATION 0		102	BLANK	101	Jan 20/2005
1	Jan 20/2005	53-10-52 REPAIR GENERAL		102	Jan 20/2005
2	BLANK	201	Jan 20/2005	103	Jan 20/2005
53-10-50 ALLOWABLE DAMAGE GENERAL		202	BLANK	104	Jan 20/2005
101	Jan 20/2005	53-10-72 IDENTIFICATION 1		53-10-90 REPAIR GENERAL	
102	BLANK	1	Jan 20/2005	201	Jan 20/2005
53-10-50 REPAIR GENERAL		2	Jan 20/2005	202	BLANK
201	Jan 20/2005	3	Jan 20/2005	53-11-72 REPAIR GENERAL	
202	BLANK	4	BLANK	201	Jan 20/2005
53-10-51 IDENTIFICATION 1		53-10-72 ALLOWABLE DAMAGE 1		202	Jan 20/2005
1	Jan 20/2005	101	Jan 20/2005	203	Jan 20/2005
2	Jan 20/2005	102	Jan 20/2005	204	Jan 20/2005
3	Jan 20/2005	103	Jan 20/2005	205	Jan 20/2005
4	Jan 20/2005	104	BLANK	206	Jan 20/2005
				207	Jan 20/2005

A = Added, R = Revised, O = Overflow, D = Deleted

53-EFFECTIVE PAGES



**757-200
STRUCTURAL REPAIR MANUAL**

**CHAPTER 53
FUSELAGE**

Subject/Page	Date	Subject/Page	Date	Subject/Page	Date
53-11-72 REPAIR GENERAL (cont)		53-30-01 REPAIR 1		53-30-07 IDENTIFICATION 1 (cont)	
208	Jan 20/2005	201	Jan 20/2006	7	Jan 20/2006
209	Jan 20/2005	202	BLANK	8	May 20/2006
210	Jan 20/2005	53-30-03 IDENTIFICATION 1		9	May 20/2006
211	Jan 20/2005	1	Jan 20/2005	10	May 20/2006
212	Jan 20/2005	2	Jan 20/2005	11	May 20/2006
213	Jan 20/2005	3	Jan 20/2005	12	May 20/2006
214	Jan 20/2005	4	Jan 20/2005	13	May 20/2006
215	Jan 20/2005	53-30-03 ALLOWABLE DAMAGE GENERAL		14	May 20/2006
216	Jan 20/2005	101	Jan 20/2007	15	May 20/2006
217	Jan 20/2005	102	BLANK	16	May 20/2006
218	Jan 20/2005	53-30-03 REPAIR GENERAL		53-30-07 ALLOWABLE DAMAGE GENERAL	
219	Jan 20/2005	201	Jan 20/2005	101	Jan 20/2007
220	Jan 20/2005	202	BLANK	102	BLANK
221	Jan 20/2005	53-30-03 REPAIR 1		53-30-07 REPAIR GENERAL	
222	Jan 20/2005	201	Feb 20/2005	201	Jan 20/2005
223	Jan 20/2005	202	Jan 20/2005	202	BLANK
224	Jan 20/2005	203	Jan 20/2005	53-30-12 IDENTIFICATION 1	
225	Jan 20/2005	204	Jan 20/2005	1	Jan 20/2005
226	Jan 20/2005	205	Jan 20/2005	2	Jan 20/2005
227	Jan 20/2005	206	BLANK	53-30-12 ALLOWABLE DAMAGE 1	
228	Jan 20/2005	53-30-04 IDENTIFICATION 1		101	Jan 20/2007
229	Jan 20/2005	1	Jan 20/2005	102	Jan 20/2005
230	BLANK	2	Jan 20/2005	53-30-12 REPAIR GENERAL	
53-30-01 IDENTIFICATION 1		3	Jan 20/2005	201	Sep 20/2008
1	Jan 20/2005	4	BLANK	202	BLANK
2	Jan 20/2005	53-30-04 ALLOWABLE DAMAGE GENERAL		53-30-13 IDENTIFICATION 1	
3	Jan 20/2005	101	Jan 20/2005	1	Jan 20/2005
4	Jan 20/2005	102	Jan 20/2005	2	Jan 20/2005
5	Jan 20/2005	53-30-04 REPAIR GENERAL		3	Jan 20/2005
6	BLANK	201	Jan 20/2005	4	Jan 20/2005
53-30-01 IDENTIFICATION 2		202	Jan 20/2005	5	Jan 20/2005
1	Jan 20/2005	53-30-07 IDENTIFICATION 1		6	Jan 20/2005
2	BLANK	1	Jan 20/2006	7	Jan 20/2005
53-30-01 ALLOWABLE DAMAGE 1		2	Jan 20/2006	8	BLANK
101	Jan 20/2005	3	Jan 20/2006	53-30-13 ALLOWABLE DAMAGE 1	
102	BLANK	4	Jan 20/2006	101	Jan 20/2006
53-30-01 REPAIR GENERAL		5	Jan 20/2006	102	Jan 20/2006
201	Jan 20/2005	6	Jan 20/2006	103	Jan 20/2006
202	BLANK				

A = Added, R = Revised, O = Overflow, D = Deleted

53-EFFECTIVE PAGES



**757-200
STRUCTURAL REPAIR MANUAL**

**CHAPTER 53
FUSELAGE**

Subject/Page	Date	Subject/Page	Date	Subject/Page	Date
53-30-13 ALLOWABLE DAMAGE 1 (cont)		53-30-50 ALLOWABLE DAMAGE GENERAL		53-30-53 IDENTIFICATION 1 (cont)	
104	Jan 20/2006	101	Jan 20/2005	2	Jan 20/2005
105	Jan 20/2006	102	BLANK	3	Jan 20/2005
106	BLANK	53-30-50 REPAIR GENERAL		4	Jan 20/2005
53-30-15 IDENTIFICATION 1		201	Jan 20/2005	5	Jan 20/2005
1	Jan 20/2005	202	BLANK	6	Jan 20/2005
2	Jan 20/2005	53-30-51 IDENTIFICATION 1		7	Jan 20/2005
3	Jan 20/2005	1	Jan 20/2005	8	BLANK
4	Jan 20/2005	2	Jan 20/2005	53-30-53 ALLOWABLE DAMAGE GENERAL	
5	Jan 20/2005	3	Jan 20/2005	101	Jan 20/2005
6	Jan 20/2005	4	Jan 20/2005	102	BLANK
7	Jan 20/2005	5	Jan 20/2005	53-30-53 REPAIR GENERAL	
8	Jan 20/2005	6	Jan 20/2005	201	Jan 20/2005
9	Jan 20/2005	7	Jan 20/2005	202	Jan 20/2005
10	BLANK	8	Jan 20/2005	53-30-70 IDENTIFICATION 1	
53-30-15 ALLOWABLE DAMAGE 1		9	Jan 20/2005	1	Jan 20/2007
101	Jan 20/2005	10	BLANK	2	May 20/2007
102	Jan 20/2005	53-30-51 ALLOWABLE DAMAGE GENERAL		3	May 20/2007
103	Jan 20/2005	101	Jan 20/2005	4	May 20/2007
104	Jan 20/2005	102	BLANK	5	May 20/2007
105	Jan 20/2005	53-30-51 REPAIR GENERAL		6	May 20/2007
106	Jan 20/2005	201	Jan 20/2005	7	May 20/2007
107	Jan 20/2005	202	Jan 20/2005	8	May 20/2007
108	BLANK	53-30-52 IDENTIFICATION 1		9	May 20/2007
53-30-15 ALLOWABLE DAMAGE 2		1	Jan 20/2005	10	May 20/2007
101	Jan 20/2005	2	Jan 20/2005	11	May 20/2007
102	Jan 20/2005	3	Jan 20/2005	12	May 20/2007
103	Jan 20/2005	4	Jan 20/2005	53-30-70 ALLOWABLE DAMAGE GENERAL	
104	Jan 20/2005	5	Jan 20/2005	101	Jan 20/2005
105	Jan 20/2005	6	BLANK	102	BLANK
106	BLANK	53-30-52 ALLOWABLE DAMAGE GENERAL		53-30-70 REPAIR GENERAL	
53-30-15 REPAIR GENERAL		101	Jan 20/2005	201	Jan 20/2005
201	Jan 20/2005	102	BLANK	202	BLANK
202	Jan 20/2005	53-30-52 REPAIR GENERAL		53-30-71 IDENTIFICATION 1	
203	Jan 20/2005	201	Jan 20/2005	1	Jan 20/2005
204	BLANK	202	BLANK	2	Jan 20/2005
53-30-50 IDENTIFICATION 0		53-30-53 IDENTIFICATION 1		3	Jan 20/2005
1	Jan 20/2005	1	Jan 20/2005	4	BLANK
2	BLANK				

A = Added, R = Revised, O = Overflow, D = Deleted

53-EFFECTIVE PAGES



**757-200
STRUCTURAL REPAIR MANUAL**

**CHAPTER 53
FUSELAGE**

Subject/Page	Date	Subject/Page	Date	Subject/Page	Date
53-30-71 ALLOWABLE DAMAGE GENERAL		53-40-07 IDENTIFICATION 1		53-40-12 IDENTIFICATION 1	
101	Jan 20/2005	1	Jan 20/2005	1	Feb 20/2005
102	BLANK	2	Jan 20/2005	2	May 20/2005
53-30-71 REPAIR GENERAL		3	Jan 20/2005	3	May 20/2005
201	Jan 20/2005	4	Jan 20/2005	4	May 20/2005
202	BLANK	5	Jan 20/2005	53-40-12 ALLOWABLE DAMAGE 1	
53-40-01 IDENTIFICATION 1		6	Jan 20/2005	101	Jan 20/2007
1	Jan 20/2005	7	Jan 20/2005	102	Jan 20/2005
2	May 20/2008	8	BLANK	103	Jan 20/2005
3	May 20/2008	53-40-07 ALLOWABLE DAMAGE GENERAL		104	Jan 20/2005
4	BLANK	101	Jan 20/2005	105	Jan 20/2005
53-40-01 ALLOWABLE DAMAGE GENERAL		102	BLANK	106	Jan 20/2005
101	Jan 20/2005	53-40-07 REPAIR GENERAL		107	Jan 20/2005
102	BLANK	201	Jan 20/2005	108	BLANK
53-40-01 REPAIR GENERAL		202	BLANK	53-40-12 REPAIR GENERAL	
201	Jan 20/2005	53-40-08 IDENTIFICATION 1		201	Jan 20/2005
202	BLANK	1	Jan 20/2005	202	BLANK
53-40-03 IDENTIFICATION 1		2	Jan 20/2005	53-40-13 IDENTIFICATION 1	
1	Jan 20/2005	3	Jan 20/2005	1	Jan 20/2005
2	Jan 20/2005	4	Jan 20/2005	2	Jan 20/2005
3	Jan 20/2005	53-40-08 ALLOWABLE DAMAGE GENERAL		3	Jan 20/2005
4	BLANK	101	Jan 20/2007	4	Jan 20/2005
53-40-03 ALLOWABLE DAMAGE GENERAL		102	BLANK	53-40-13 ALLOWABLE DAMAGE 1	
101	Jan 20/2005	53-40-08 ALLOWABLE DAMAGE 1		101	Jan 20/2007
102	BLANK	101	Jan 20/2005	102	Jan 20/2005
53-40-03 REPAIR GENERAL		102	Jan 20/2005	103	Jan 20/2005
201	Jan 20/2005	103	Jan 20/2005	104	Jan 20/2005
202	BLANK	104	BLANK	53-40-14 IDENTIFICATION 1	
53-40-04 IDENTIFICATION 1		53-40-08 ALLOWABLE DAMAGE 2		1	Jan 20/2005
1	Jan 20/2005	101	Jan 20/2005	2	Jan 20/2005
2	BLANK	102	Jan 20/2005	3	Jan 20/2005
53-40-04 ALLOWABLE DAMAGE GENERAL		103	Jan 20/2005	4	BLANK
101	Jan 20/2005	104	BLANK	53-40-14 ALLOWABLE DAMAGE 1	
102	BLANK	53-40-08 ALLOWABLE DAMAGE 3		101	Jan 20/2005
53-40-04 REPAIR GENERAL		101	Jan 20/2005	102	Jan 20/2005
201	Jan 20/2005	102	Jan 20/2005	103	Jan 20/2005
202	BLANK	103	Jan 20/2005	104	Jan 20/2005
		104	BLANK	105	Jan 20/2005
				106	Jan 20/2005

A = Added, R = Revised, O = Overflow, D = Deleted

53-EFFECTIVE PAGES



**757-200
STRUCTURAL REPAIR MANUAL**

**CHAPTER 53
FUSELAGE**

Subject/Page	Date	Subject/Page	Date	Subject/Page	Date
53-40-14 REPAIR GENERAL		53-40-70 IDENTIFICATION 1 (cont)		53-40-90 REPAIR GENERAL	
201	Jan 20/2005	5	May 20/2007	201	Jan 20/2005
202	BLANK	6	Sep 20/2007	202	BLANK
53-40-15 IDENTIFICATION 1		7	Sep 20/2007	53-40-90 REPAIR 1	
1	Jan 20/2005	8	Sep 20/2007	201	Jan 20/2005
2	Jan 20/2005	9	Sep 20/2007	202	Jan 20/2005
3	Jan 20/2005	10	Sep 20/2007	53-60-01 IDENTIFICATION 1	
4	BLANK	11	Sep 20/2007	1	Jan 20/2005
53-40-50 IDENTIFICATION 0		12	Sep 20/2007	2	Jan 20/2005
1	Jan 20/2005	13	Sep 20/2007	3	Jan 20/2005
2	BLANK	14	Sep 20/2007	4	Jan 20/2005
53-40-50 ALLOWABLE DAMAGE GENERAL		15	Sep 20/2007	5	Jan 20/2005
101	Jan 20/2005	16	Sep 20/2007	6	Jan 20/2005
102	BLANK	17	Sep 20/2007	7	Jan 20/2005
53-40-50 REPAIR GENERAL		18	Sep 20/2007	8	BLANK
201	Jan 20/2005	53-40-70 ALLOWABLE DAMAGE GENERAL		53-60-01 IDENTIFICATION 2	
202	BLANK	101	Jan 20/2005	1	Jan 20/2005
53-40-51 IDENTIFICATION 1		102	Jan 20/2005	2	BLANK
1	Jan 20/2005	103	Jan 20/2005	53-60-01 ALLOWABLE DAMAGE GENERAL	
2	Jan 20/2005	104	Jan 20/2005	101	Jan 20/2005
3	Jan 20/2005	53-40-70 REPAIR GENERAL		102	BLANK
4	Jan 20/2005	201	Jan 20/2005	53-60-01 REPAIR GENERAL	
53-40-51 ALLOWABLE DAMAGE 1		202	BLANK	201	Jan 20/2005
101	Jan 20/2007	53-40-71 IDENTIFICATION 1		202	Jan 20/2005
102	BLANK	1	Jan 20/2005	53-60-03 IDENTIFICATION 1	
53-40-52 IDENTIFICATION 1		2	Jan 20/2005	1	Jan 20/2005
1	Jan 20/2005	3	Jan 20/2005	2	Jan 20/2005
2	Jan 20/2005	4	Jan 20/2005	3	Jan 20/2005
53-40-52 ALLOWABLE DAMAGE GENERAL		5	Jan 20/2005	4	Jan 20/2005
101	Jan 20/2007	6	Jan 20/2005	5	Jan 20/2005
102	BLANK	7	Jan 20/2005	6	Jan 20/2005
53-40-52 REPAIR GENERAL		8	BLANK	7	Jan 20/2005
201	Jan 20/2005	53-40-71 ALLOWABLE DAMAGE GENERAL		8	Jan 20/2005
202	BLANK	101	Jan 20/2005	53-60-03 ALLOWABLE DAMAGE GENERAL	
53-40-70 IDENTIFICATION 1		102	BLANK	101	Jan 20/2007
1	May 20/2007	53-40-71 REPAIR GENERAL		102	BLANK
2	May 20/2007	201	Jan 20/2005	53-60-03 REPAIR GENERAL	
3	May 20/2007	202	Jan 20/2005	201	Jan 20/2005
4	May 20/2007			202	BLANK

A = Added, R = Revised, O = Overflow, D = Deleted

53-EFFECTIVE PAGES



**757-200
STRUCTURAL REPAIR MANUAL**

**CHAPTER 53
FUSELAGE**

Subject/Page	Date	Subject/Page	Date	Subject/Page	Date
53-60-04 IDENTIFICATION 1		53-60-12 IDENTIFICATION 1 (cont)		53-60-15 ALLOWABLE DAMAGE 1	
1	Jan 20/2005	2	Jan 20/2005	101	Jan 20/2005
2	Jan 20/2005	53-60-12 ALLOWABLE DAMAGE 1		102	Jan 20/2005
3	Jan 20/2005	101	Jan 20/2007	103	Jan 20/2005
4	Jan 20/2005	102	Jan 20/2005	104	Jan 20/2005
53-60-04 ALLOWABLE DAMAGE GENERAL		53-60-12 REPAIR GENERAL		105	Jan 20/2005
101	Jan 20/2007	201	Sep 20/2008	106	Sep 20/2005
102	Jan 20/2005	202	BLANK	107	Jan 20/2005
103	Jan 20/2005	53-60-13 IDENTIFICATION 1		108	BLANK
104	BLANK	1	Jan 20/2006	53-60-15 ALLOWABLE DAMAGE 2	
53-60-04 REPAIR GENERAL		2	Jan 20/2006	101	Jan 20/2005
201	Jan 20/2005	3	Jan 20/2006	102	Jan 20/2005
202	Jan 20/2005	4	Jan 20/2006	53-60-15 REPAIR GENERAL	
203	Jan 20/2005	5	Jan 20/2006	201	Jan 20/2005
204	BLANK	6	Jan 20/2006	202	BLANK
53-60-07 IDENTIFICATION 1		53-60-13 ALLOWABLE DAMAGE 1		53-60-15 REPAIR 1	
1	Jan 20/2005	101	Jan 20/2007	201	Jan 20/2005
2	Jan 20/2005	102	Jan 20/2005	202	Jan 20/2005
3	Jan 20/2005	103	Jan 20/2005	203	Jan 20/2005
4	Jan 20/2005	104	Jan 20/2005	204	Jan 20/2005
5	Jan 20/2005	105	Jan 20/2005	205	Jan 20/2005
6	Jan 20/2005	106	BLANK	206	BLANK
7	Jan 20/2005	53-60-13 ALLOWABLE DAMAGE 2		53-60-50 IDENTIFICATION 0	
8	Jan 20/2005	101	Jan 20/2005	1	Jan 20/2005
9	Jan 20/2005	102	Jan 20/2005	2	BLANK
10	Jan 20/2005	103	Jan 20/2005	53-60-50 ALLOWABLE DAMAGE GENERAL	
11	Jan 20/2005	104	Jan 20/2005	101	Jan 20/2005
12	BLANK	105	Jan 20/2005	102	BLANK
53-60-07 ALLOWABLE DAMAGE GENERAL		106	BLANK	53-60-50 REPAIR GENERAL	
101	Jan 20/2005	53-60-15 IDENTIFICATION 1		201	Jan 20/2005
102	BLANK	1	Jan 20/2005	202	BLANK
53-60-07 REPAIR GENERAL		2	Jan 20/2005	53-60-51 IDENTIFICATION 1	
201	Jan 20/2005	3	Jan 20/2005	1	Jan 20/2005
202	BLANK	4	Jan 20/2005	2	Sep 20/2006
53-60-08 IDENTIFICATION 1		5	Jan 20/2005	3	Sep 20/2006
1	Jan 20/2005	6	Jan 20/2005	4	Sep 20/2006
2	BLANK	7	Jan 20/2005	5	Sep 20/2006
53-60-12 IDENTIFICATION 1		8	Jan 20/2005	6	Sep 20/2006
1	Jan 20/2005	9	Jan 20/2005	7	Jan 20/2005
		10	BLANK		

A = Added, R = Revised, O = Overflow, D = Deleted

53-EFFECTIVE PAGES



**757-200
STRUCTURAL REPAIR MANUAL**

**CHAPTER 53
FUSELAGE**

Subject/Page	Date	Subject/Page	Date	Subject/Page	Date
53-60-51 IDENTIFICATION 1 (cont)		53-60-53 IDENTIFICATION 1 (cont)		53-60-71 IDENTIFICATION 1 (cont)	
8	BLANK	8	Jan 20/2005	4	Jan 20/2005
53-60-51 ALLOWABLE DAMAGE GENERAL		9	Jan 20/2005	5	Jan 20/2005
101	Jan 20/2005	10	Jan 20/2005	6	BLANK
102	BLANK	11	Jan 20/2005	53-60-71 IDENTIFICATION 2	
53-60-51 REPAIR GENERAL		12	Jan 20/2005	1	Jan 20/2005
201	Sep 20/2005	13	Jan 20/2005	2	BLANK
202	BLANK	14	BLANK	53-60-71 ALLOWABLE DAMAGE GENERAL	
53-60-51 REPAIR 1		53-60-53 ALLOWABLE DAMAGE GENERAL		101	Jan 20/2005
201	Jan 20/2005	101	Jan 20/2005	102	BLANK
202	Jan 20/2005	102	BLANK	53-60-71 ALLOWABLE DAMAGE 1	
53-60-51 REPAIR 2		53-60-53 REPAIR GENERAL		101	Jan 20/2005
201	Jan 20/2005	201	Jan 20/2005	102	Jan 20/2005
202	Jan 20/2005	202	Jan 20/2005	103	Jan 20/2005
203	Jan 20/2005	53-60-70 IDENTIFICATION 1		104	BLANK
204	Jan 20/2005	1	Jan 20/2005	53-60-71 REPAIR GENERAL	
205	Jan 20/2005	2	Jan 20/2005	201	Jan 20/2005
206	BLANK	3	Jan 20/2005	202	BLANK
53-60-52 IDENTIFICATION 1		4	Jan 20/2005	53-60-71 REPAIR 1	
1	Jan 20/2005	5	Jan 20/2005	201	Jan 20/2005
2	Jan 20/2005	6	Jan 20/2005	202	Jan 20/2005
3	Jan 20/2005	7	Jan 20/2005	203	Jan 20/2005
4	Jan 20/2005	8	Jan 20/2005	204	BLANK
5	Jan 20/2005	53-60-70 IDENTIFICATION 2		53-80-01 IDENTIFICATION 1	
6	BLANK	1	Jan 20/2005	1	Jan 20/2005
53-60-52 ALLOWABLE DAMAGE GENERAL		2	BLANK	2	Jan 20/2005
101	Jan 20/2005	53-60-70 ALLOWABLE DAMAGE GENERAL		3	Sep 20/2005
102	BLANK	101	Jan 20/2005	4	Jan 20/2005
53-60-52 REPAIR GENERAL		102	BLANK	5	Jan 20/2005
201	Jan 20/2005	53-60-70 ALLOWABLE DAMAGE 1		6	Jan 20/2005
202	BLANK	101	Jan 20/2005	7	Jan 20/2005
53-60-53 IDENTIFICATION 1		102	Jan 20/2005	8	BLANK
1	Jan 20/2005	53-60-70 REPAIR GENERAL		53-80-01 ALLOWABLE DAMAGE GENERAL	
2	Jan 20/2005	201	Jan 20/2005	101	Jan 20/2005
3	Jan 20/2005	202	BLANK	102	Jan 20/2005
4	Jan 20/2005	53-60-71 IDENTIFICATION 1		103	Jan 20/2005
5	Jan 20/2005	1	Jan 20/2005	104	Jan 20/2005
6	Jan 20/2005	2	Jan 20/2005	105	Jan 20/2005
7	Jan 20/2005	3	Jan 20/2005	106	Jan 20/2005

A = Added, R = Revised, O = Overflow, D = Deleted

53-EFFECTIVE PAGES



**757-200
STRUCTURAL REPAIR MANUAL**

**CHAPTER 53
FUSELAGE**

Subject/Page	Date	Subject/Page	Date	Subject/Page	Date
53-80-01 REPAIR GENERAL		53-80-05 IDENTIFICATION 1 (cont)		53-80-08 IDENTIFICATION 1 (cont)	
201	Jan 20/2005	3	Jan 20/2005	9	Sep 20/2007
202	BLANK	4	BLANK	10	Jan 20/2005
53-80-02 IDENTIFICATION 1		53-80-05 IDENTIFICATION 2		11	Jan 20/2005
1	Jan 20/2005	1	Jan 20/2005	12	BLANK
2	Jan 20/2005	2	BLANK	53-80-08 ALLOWABLE DAMAGE 1	
53-80-02 ALLOWABLE DAMAGE GENERAL		53-80-05 ALLOWABLE DAMAGE 1		101	Jan 20/2005
101	Jan 20/2007	101	Jan 20/2005	102	Jan 20/2005
102	Jan 20/2005	102	Jan 20/2005	103	Jan 20/2005
103	Jan 20/2005	103	Jan 20/2005	104	Jan 20/2005
104	Jan 20/2005	104	Jan 20/2005	105	Jan 20/2005
53-80-03 IDENTIFICATION 1		105	Jan 20/2005	106	Jan 20/2005
1	Jan 20/2005	106	Jan 20/2005	107	Jan 20/2005
2	Jan 20/2005	107	Jan 20/2005	108	Jan 20/2005
3	Jan 20/2005	108	BLANK	109	Jan 20/2005
4	Jan 20/2005	53-80-07 IDENTIFICATION 1		110	Jan 20/2005
5	Jan 20/2005	1	Jan 20/2005	111	Jan 20/2005
6	BLANK	2	Jan 20/2005	112	BLANK
53-80-03 ALLOWABLE DAMAGE GENERAL		3	Jan 20/2005	53-80-08 REPAIR GENERAL	
101	Jan 20/2005	4	Jan 20/2005	201	Jan 20/2005
102	BLANK	5	Jan 20/2005	202	BLANK
53-80-03 REPAIR GENERAL		6	Jan 20/2005	53-80-08 REPAIR 1	
201	Jan 20/2005	7	Jan 20/2005	201	Jan 20/2005
202	BLANK	8	Jan 20/2005	202	Jan 20/2005
53-80-04 IDENTIFICATION 1		53-80-07 ALLOWABLE DAMAGE GENERAL		203	Jan 20/2005
1	Jan 20/2005	101	Jan 20/2007	204	Feb 20/2005
2	Jan 20/2005	102	BLANK	205	Jan 20/2005
3	Jan 20/2005	53-80-07 REPAIR GENERAL		206	Jan 20/2005
4	Jan 20/2005	201	Jan 20/2005	207	Jan 20/2005
53-80-04 ALLOWABLE DAMAGE GENERAL		202	BLANK	208	BLANK
101	Jan 20/2007	53-80-08 IDENTIFICATION 1		53-80-08 REPAIR 2	
102	Jan 20/2005	1	Jan 20/2005	201	Feb 20/2005
53-80-04 REPAIR GENERAL		2	Jan 20/2005	202	Jan 20/2005
201	Jan 20/2005	3	Jan 20/2005	53-80-08 REPAIR 3	
202	Jan 20/2005	4	Jan 20/2005	201	Feb 20/2005
53-80-05 IDENTIFICATION 1		5	Jan 20/2005	202	Jan 20/2005
1	Jan 20/2005	6	Jan 20/2005	53-80-13 IDENTIFICATION 1	
2	Jan 20/2005	7	Jan 20/2005	1	Jan 20/2005
		8	Jan 20/2005	2	Jan 20/2005
				3	Jan 20/2005

A = Added, R = Revised, O = Overflow, D = Deleted

53-EFFECTIVE PAGES



**757-200
STRUCTURAL REPAIR MANUAL**

**CHAPTER 53
FUSELAGE**

Subject/Page	Date	Subject/Page	Date	Subject/Page	Date
53-80-13 IDENTIFICATION 1 (cont)		53-80-31 REPAIR 3		53-80-90 REPAIR GENERAL (cont)	
4	BLANK	201	May 20/2008	202	Jan 20/2005
53-80-13 ALLOWABLE DAMAGE 1		202	May 20/2008	203	Jan 20/2005
101	Jan 20/2005	203	May 20/2008	204	Jan 20/2005
102	Jan 20/2005	204	May 20/2008	205	Jan 20/2005
103	Jan 20/2005	53-80-31 REPAIR 4		206	Jan 20/2005
104	Jan 20/2005	201	May 20/2008		
105	Jan 20/2005	202	May 20/2008		
106	BLANK	203	May 20/2008		
53-80-30 IDENTIFICATION 1		204	BLANK		
1	Jan 20/2005	53-80-70 IDENTIFICATION 1			
2	Jan 20/2005	1	Jan 20/2005		
3	Jan 20/2005	2	Jan 20/2005		
4	Jan 20/2005	53-80-70 ALLOWABLE DAMAGE 1			
5	Jan 20/2005	101	Jan 20/2007		
6	BLANK	102	Jan 20/2005		
53-80-30 ALLOWABLE DAMAGE 1		103	Jan 20/2005		
101	Jan 20/2005	104	Jan 20/2005		
102	BLANK	53-80-71 IDENTIFICATION 1			
53-80-30 REPAIR GENERAL		1	Jan 20/2005		
201	Jan 20/2005	2	Jan 20/2005		
202	BLANK	53-80-90 IDENTIFICATION 1			
53-80-31 IDENTIFICATION 1		1	Jan 20/2005		
1	May 20/2008	2	Jan 20/2005		
2	May 20/2008	3	Jan 20/2005		
3	May 20/2008	4	Jan 20/2005		
4	BLANK	5	Jan 20/2005		
53-80-31 ALLOWABLE DAMAGE 1		6	Jan 20/2005		
101	May 20/2008	53-80-90 ALLOWABLE DAMAGE GENERAL			
102	May 20/2008	101	Jan 20/2007		
53-80-31 REPAIR 1		102	Jan 20/2005		
201	May 20/2008	103	Jan 20/2005		
202	May 20/2008	104	Jan 20/2005		
203	May 20/2008	105	Jan 20/2005		
204	May 20/2008	106	Jan 20/2005		
53-80-31 REPAIR 2		107	Jan 20/2005		
201	May 20/2008	108	BLANK		
202	May 20/2008	53-80-90 REPAIR GENERAL			
203	May 20/2008	201	Jan 20/2005		
204	May 20/2008				

A = Added, R = Revised, O = Overflow, D = Deleted

53-EFFECTIVE PAGES



757-200
STRUCTURAL REPAIR MANUAL

CHAPTER 53
FUSELAGE

<u>SUBJECT</u>	<u>CHAPTER SECTION SUBJECT</u>
<u>FUSELAGE - GENERAL</u>	53-00-00
GENERAL - Fuselage	
<u>FUSELAGE SKIN - GENERAL</u>	53-00-01
ALLOWABLE DAMAGE 1 - Fuselage Skin	
ALLOWABLE DAMAGE 2 - Operating Limits for Fuselage Skin	
REPAIR GENERAL - Fuselage Skin - Definition of Repair Zones and Service Bulletin Chart	
REPAIR 1 - Method of Using Briles Rivet Head as Repair Washer for External Skin Repair	
REPAIR 2 - Fuselage Skin - External Repair for Damage at a Stringer with Solid Fasteners	
REPAIR 3 - Fuselage Skin - External Repair for Damage Between Stringers with Solid Fasteners	
REPAIR 4 - Fuselage Skin - Flush Repair at a Stringer	
REPAIR 5 - Fuselage Skin - Flush Repair Between Stringers	
REPAIR 6 - Repair of Lightning Strike Damage on Pressurized Fuselage Skin	
REPAIR 7 - Fuselage Skin - Small Hole Flush Repair	
REPAIR 8 - Fuselage Skin Repair Near the Primary Static Ports	
REPAIR 9 - Fuselage Skin Crease Repair at BS 600 Between Stringers 27L and 27R	
REPAIR 10 - Fuselage Skin Crease Repair at BS 580 Between Stringers 27L and 27R	
REPAIR 11 - Fuselage Skin Crease Repair at BS 1420 Between Stringers 28L and 28R	
REPAIR 12 - Repair of Skin Tear Strap Disbond Between Stringers 10L and 10R - Section 43 and 46	
REPAIR 13 - Fuselage Skin - External Repair for Damage at a Stringer with Blind Fasteners	
REPAIR 14 - Fuselage Skin - External Repair for Damage Between Stringers with Blind Fasteners	
REPAIR 15 - Fuselage Skin - External Repair for Damage at a Stringer with Solid Fasteners - 757-SF	

53-CONTENTS



757-200
STRUCTURAL REPAIR MANUAL

CHAPTER 53
FUSELAGE

<u>SUBJECT</u>	<u>CHAPTER SECTION SUBJECT</u>
REPAIR 16 - Fuselage Skin - External Repair for Damage Between Stringers with Solid Fasteners - 757-SF	
REPAIR 17 - Fuselage Skin Repair Near the Primary Static Ports - 757-SF	
<u>FUSELAGE STRINGERS</u>	53-00-03
ALLOWABLE DAMAGE 1 - Fuselage Stringers	
REPAIR 1 - Fuselage Stringer Repair S-1 thru S-30	
REPAIR 2 - Fuselage Stringer Repair S-1 thru S-30 - 757-SF	
<u>FUSELAGE INTERCOSTALS</u>	53-00-04
ALLOWABLE DAMAGE 1 - Intercostals	
<u>FUSELAGE FRAMES</u>	53-00-07
ALLOWABLE DAMAGE 1 - Fuselage Frames	
ALLOWABLE DAMAGE 2 - Fuselage Frames - 757-SF	
REPAIR 1 - Fuselage Formed Zee Frame Repair	
REPAIR 2 - Fuselage Built-Up Frame Web Repair	
REPAIR 3 - Fuselage Formed Zee Frame Repair - 757-SF	
REPAIR 4 - Fuselage Built-Up Frame Web Repair - 757-SF	
REPAIR 5 - Fuselage Lower Lobe Frame Repairs in the Forward and Aft Cargo Compartments	
<u>FUSELAGE FLOOR PANELS</u>	53-00-50
IDENTIFICATION 1 - Main Deck Floor Panel	
ALLOWABLE DAMAGE 1 - Main Deck Floor Panels	
ALLOWABLE DAMAGE 2 - Main Deck Floor Panels - 757-SF	
REPAIR 1 - Main Deck Floor Panel Repairs	
<u>FUSELAGE FLOOR STRUCTURE</u>	53-00-51
ALLOWABLE DAMAGE 1 - Floor Structure	
REPAIR 1 - Floor Beam Upper Chord Under Seat Track Repair	
REPAIR 2 - Floor Beam Upper Chord Repair at BS 1681	
REPAIR 3 - Floor Beam Upper Chord Repair Away From a Seat Track	

53-CONTENTS



757-200
STRUCTURAL REPAIR MANUAL

CHAPTER 53
FUSELAGE

<u>SUBJECT</u>	<u>CHAPTER SECTION SUBJECT</u>
REPAIR 4 - Floor Structure - Intercostal Upper Chord General Repair	
REPAIR 5 - Repair to One Flange of the Floor Beam Upper or Lower Chord	
<u>FUSELAGE SEAT TRACKS</u>	53-00-52
ALLOWABLE DAMAGE 1 - Seat Tracks	
REPAIR 1 - Seat Track Repair (BAC1520-792) - Option 1	
REPAIR 2 - Hole Pattern for Seat Track Repairs	
REPAIR 3 - Seat Track Repair (BAC1520-792) - Option 2	
REPAIR 4 - Seat Track Repair (BAC1520-841)	
<u>CARGO COMPARTMENT STRUCTURE</u>	53-00-53
ALLOWABLE DAMAGE 1 - Cargo Compartment Structure	
<u>FUSELAGE FAIRING SKIN</u>	53-00-70
ALLOWABLE DAMAGE 1 - Wing to Body Fairing Skin	
REPAIR 1 - Wing To Body Fairing Skin Repairs	
<u>FUSELAGE FAIRING STRUCTURE - ALLOWABLE DAMAGE</u>	53-00-71
ALLOWABLE DAMAGE 1 - Wing to Body Fairing Structure	
<u>FUSELAGE SKINS - SECTION 41</u>	53-10-01
IDENTIFICATION 1 - Section 41 - Skins	
IDENTIFICATION 2 - Section 41 - Rain Gutter	
ALLOWABLE DAMAGE GENERAL - Section 41 - Skins	
REPAIR GENERAL - Section 41 - Fuselage Skins	
REPAIR 1 - Rain Gutter Repair at Passenger/Crew Entry Doors	
<u>FUSELAGE STRINGERS - SECTION 41</u>	53-10-03
IDENTIFICATION 1 - Section 41 - Stringers	
ALLOWABLE DAMAGE GENERAL - Section 41 - Stringers	
REPAIR GENERAL - Section 41 - Stringers	
<u>FUSELAGE INTERCOSTALS - SECTION 41</u>	53-10-04
IDENTIFICATION 1 - Section 41 - Intercostals	

53-CONTENTS



757-200
STRUCTURAL REPAIR MANUAL

CHAPTER 53
FUSELAGE

<u>SUBJECT</u>	<u>CHAPTER SECTION SUBJECT</u>
ALLOWABLE DAMAGE GENERAL - Section 41 - Intercostals	
REPAIR GENERAL - Section 41 - Intercostals	
<u>FUSELAGE FRAMES - SECTION 41</u>	53-10-07
IDENTIFICATION 1 - Section 41 - Frames	
ALLOWABLE DAMAGE GENERAL - Section 41 - Frames	
REPAIR GENERAL - Section 41 - Frames	
<u>FUSELAGE BULKHEADS - SECTION 41</u>	53-10-08
IDENTIFICATION 1 - Section 41 - Bulkheads	
ALLOWABLE DAMAGE 1 - Section 41 - Bulkheads	
<u>CREASE BEAM STRUCTURE - SECTION 41</u>	53-10-13
IDENTIFICATION 1 - Section 41 - Crease Beam	
<u>LANDING GEAR SUPPORT STRUCTURE - SECTION 41</u>	53-10-14
IDENTIFICATION 1 - Nose Wheel Well Structure	
ALLOWABLE DAMAGE 1 - Nose Wheel Well Structure	
REPAIR GENERAL - Nose Wheel Well Structure	
<u>FUSELAGE DOOR SURROUND STRUCTURE - SECTION 41</u>	53-10-15
IDENTIFICATION 1 - Section 41 - Door Surround Structure	
ALLOWABLE DAMAGE 1 - Section 41 - Door Surround Structure	
REPAIR GENERAL - Section 41 - Door Surround Structure	
<u>FUSELAGE FLOOR PANELS - SECTION 41</u>	53-10-50
IDENTIFICATION GENERAL - Section 41 - Main Deck Floor Panels	
ALLOWABLE DAMAGE GENERAL - Section 41 - Main Deck Floor Panels	
REPAIR GENERAL - Section 41 - Main Deck Floor Panel Repairs	
<u>FUSELAGE MAIN DECK FLOOR STRUCTURE - SECTION 41</u>	53-10-51
IDENTIFICATION 1 - Section 41 - Main Deck Floor Structure	
ALLOWABLE DAMAGE GENERAL - Section 41 - Main Deck Floor Structure	
REPAIR GENERAL - Section 41 - Main Deck Floor Structure	

53-CONTENTS



757-200
STRUCTURAL REPAIR MANUAL

CHAPTER 53
FUSELAGE

<u>SUBJECT</u>	<u>CHAPTER SECTION SUBJECT</u>
REPAIR 1 - Section 41 - Floor Structure Stabilizer Strap Crack Repair	
<u>FUSELAGE SEAT TRACKS - SECTION 41</u>	53-10-52
IDENTIFICATION 1 - Section 41 - Seat Tracks	
ALLOWABLE DAMAGE GENERAL - Section 41 - Seat Tracks	
REPAIR GENERAL - Section 41 - Seat Tracks	
<u>FUSELAGE NOSE RADOME - SECTION 41</u>	53-10-72
IDENTIFICATION 1 - Nose Radome	
ALLOWABLE DAMAGE 1 - Nose Radome	
REPAIR GENERAL - Nose Radome	
<u>FUSELAGE ATTACHMENT FITTINGS - SECTION 41</u>	53-10-90
IDENTIFICATION 1 - Nose Landing Gear Attachment Fittings	
ALLOWABLE DAMAGE 1 - Nose Landing Gear Attachment Fittings	
REPAIR GENERAL - Nose Landing Gear Attachment Fittings	
<u>FUSELAGE HITCO NOSE RADOME - SECTION 41</u>	53-11-72
REPAIR GENERAL - HITCO Nose Radome	
<u>FUSELAGE SKINS - SECTION 43</u>	53-30-01
IDENTIFICATION 1 - Section 43 - Skins	
IDENTIFICATION 2 - Rain Gutter	
ALLOWABLE DAMAGE 1 - Section 43 - Skins	
REPAIR GENERAL - Service Bulletin Repair Chart	
REPAIR 1 - Section 43 - Skins	
<u>FUSELAGE STRINGERS - SECTION 43</u>	53-30-03
IDENTIFICATION 1 - Section 43 - Stringers	
ALLOWABLE DAMAGE GENERAL - Section 43 - Stringers	
REPAIR GENERAL - Section 43 - Stringers	
REPAIR 1 - Section 43 - Stringer S-16 at the Wing Scanning Light	

53-CONTENTS



757-200
STRUCTURAL REPAIR MANUAL

CHAPTER 53
FUSELAGE

<u>SUBJECT</u>	<u>CHAPTER SECTION SUBJECT</u>
<u>FUSELAGE INTERCOSTALS - SECTION 43</u>	53-30-04
IDENTIFICATION 1 - Section 43 - Intercostals	
ALLOWABLE DAMAGE GENERAL - Section 43 - Intercostals	
REPAIR GENERAL - Section 43 - Intercostals	
<u>FUSELAGE FRAMES - SECTION 43</u>	53-30-07
IDENTIFICATION 1 - Section 43 - Frames	
ALLOWABLE DAMAGE GENERAL - Section 43 - Frames	
REPAIR GENERAL - Section 43 - Frames	
<u>FUSELAGE KEEL STRUCTURE - SECTION 43</u>	53-30-12
IDENTIFICATION 1 - Section 43 - Keel Beam Structure	
ALLOWABLE DAMAGE 1 - Section 43 - Keel Beam Structure	
REPAIR GENERAL - Section 43 - Keel Beam Structure	
<u>FUSELAGE BEAMS - SECTION 43</u>	53-30-13
IDENTIFICATION 1 - Section 43 - Crease Beam	
ALLOWABLE DAMAGE 1 - Section 43 - Crease Beam	
<u>FUSELAGE DOOR SURROUND STRUCTURE - SECTION 43</u>	53-30-15
IDENTIFICATION 1 - Section 43 - Door Surround Structure	
ALLOWABLE DAMAGE 1 - Section 43 - Door Surround Structure	
ALLOWABLE DAMAGE 2 - Main Deck Cargo Door - Door Surround Structure - 757-SF	
REPAIR GENERAL - Section 43 - Door Surround Structure	
<u>FUSELAGE FLOOR PANELS - SECTION 43</u>	53-30-50
IDENTIFICATION GENERAL - Section 43 - Main Deck Floor Panels	
ALLOWABLE DAMAGE GENERAL - Section 43 - Main Deck Floor Panels	
REPAIR GENERAL - Section 43 - Main Deck Floor Panels	
<u>FUSELAGE MAIN DECK FLOOR STRUCTURE - SECTION 43</u>	53-30-51
IDENTIFICATION 1 - Section 43 - Main Deck Floor Structure	
ALLOWABLE DAMAGE GENERAL - Section 43 - Main Deck Floor Structure	

53-CONTENTS



757-200
STRUCTURAL REPAIR MANUAL

CHAPTER 53
FUSELAGE

<u>SUBJECT</u>	<u>CHAPTER SECTION SUBJECT</u>
REPAIR GENERAL - Section 43 - Main Deck Floor Structure	
<u>FUSELAGE SEAT TRACKS - SECTION 43</u>	53-30-52
IDENTIFICATION 1 - Section 43 - Seat Tracks	
ALLOWABLE DAMAGE GENERAL - Section 43 - Seat Tracks	
REPAIR GENERAL - Section 43 - Seat Tracks	
<u>CARGO COMPARTMENT STRUCTURE - SECTION 43</u>	53-30-53
IDENTIFICATION 1 - Section 43 - Cargo Compartment Structure	
ALLOWABLE DAMAGE GENERAL - Section 43 - Cargo Compartment Structure	
REPAIR GENERAL - Section 43 - Cargo Compartment Structure	
<u>FUSELAGE FAIRING SKINS - SECTION 43</u>	53-30-70
IDENTIFICATION 1 - Section 43 - Wing-to-Body Fairing Skins	
ALLOWABLE DAMAGE GENERAL - Section 43 - Wing-to-Body Fairing Skins	
REPAIR GENERAL - Section 43 - Wing-to-Body Fairing Skins	
<u>FUSELAGE FAIRING STRUCTURE - SECTION 43</u>	53-30-71
IDENTIFICATION 1 - Section 43 - Wing-to-Body Fairing Structure	
ALLOWABLE DAMAGE GENERAL - Section 43 - Wing-to-Body Fairing Structure	
REPAIR GENERAL - Section 43 - Wing-to-Body Fairing Structure	
<u>FUSELAGE SKINS - SECTION 44</u>	53-40-01
IDENTIFICATION 1 - Section 44 - Skins	
ALLOWABLE DAMAGE GENERAL - Section 44 - Skins	
REPAIR GENERAL - Section 44 - Skins	
<u>FUSELAGE STRINGERS - SECTION 44</u>	53-40-03
IDENTIFICATION 1 - Section 44 - Stringers	
ALLOWABLE DAMAGE GENERAL - Section 44 - Stringers	
REPAIR GENERAL - Section 44 - Stringers	
<u>FUSELAGE INTERCOSTALS - SECTION 44</u>	53-40-04
IDENTIFICATION 1 - Section 44 - Intercostals	

53-CONTENTS



757-200
STRUCTURAL REPAIR MANUAL

CHAPTER 53
FUSELAGE

<u>SUBJECT</u>	<u>CHAPTER SECTION SUBJECT</u>
ALLOWABLE DAMAGE GENERAL - Section 44 - Intercostals	
REPAIR GENERAL - Section 44 - Intercostals	
<u>FUSELAGE FRAMES - SECTION 44</u>	53-40-07
IDENTIFICATION 1 - Section 44 - Frames	
ALLOWABLE DAMAGE GENERAL - Section 44 - Frames	
REPAIR GENERAL - Section 44 - Frames	
<u>FUSELAGE BULKHEADS - SECTION 44</u>	53-40-08
IDENTIFICATION 1 - Section 44 - Bulkhead Structure	
ALLOWABLE DAMAGE GENERAL - Section 44 - Bulkhead Structure	
ALLOWABLE DAMAGE 1 - Station 900 Front Spar Bulkhead	
ALLOWABLE DAMAGE 2 - Sta 1040 Rear Spar Bulkhead	
ALLOWABLE DAMAGE 3 - Sta 1180 Wheel Well Bulkhead	
<u>FUSELAGE KEEL STRUCTURE - SECTION 44</u>	53-40-12
IDENTIFICATION 1 - Section 44 - Keel Beam Structure	
ALLOWABLE DAMAGE 1 - Section 44 - Keel Beam Structure	
REPAIR GENERAL - Section 44 - Keel Beam Structure	
<u>FUSELAGE BEAMS - SECTION 44</u>	53-40-13
IDENTIFICATION 1 - Section 44 - Crease Beam	
ALLOWABLE DAMAGE 1 - Section 44 - Crease Beam	
<u>FUSELAGE LANDING GEAR SUPPORT STRUCTURE - SECTION 44</u>	53-40-14
IDENTIFICATION 1 - Section 44 - Main Landing Gear Wheel Well Structure	
ALLOWABLE DAMAGE 1 - Section 44 - Main Landing Gear Wheel Well Structure	
REPAIR GENERAL - Section 44 - Main Landing Gear Wheel Well Structure Repair	
<u>FUSELAGE DOOR SURROUND STRUCTURE - SECTION 44</u>	53-40-15
IDENTIFICATION 1 - Section 44 - Door Surround Structure	
<u>FUSELAGE FLOOR PANELS - SECTION 44</u>	53-40-50
IDENTIFICATION GENERAL - Section 44 - Main Deck Floor Panel	

53-CONTENTS



757-200
STRUCTURAL REPAIR MANUAL

CHAPTER 53
FUSELAGE

<u>SUBJECT</u>	<u>CHAPTER SECTION SUBJECT</u>
ALLOWABLE DAMAGE GENERAL - Section 44 - Main Deck Floor Panels	
REPAIR GENERAL - Section 44 - Main Deck Floor Panels	
<u>FUSELAGE MAIN AND UPPER DECK FLOOR STRUCTURE - SECTION 44</u>	53-40-51
IDENTIFICATION 1 - Section 44 - Floor Structure	
ALLOWABLE DAMAGE 1 - Section 44 - Floor Structure	
<u>FUSELAGE SEAT TRACKS - SECTION 44</u>	53-40-52
IDENTIFICATION 1 - Section 44 - Seat Tracks	
ALLOWABLE DAMAGE GENERAL - Section 44 - Seat Tracks	
REPAIR GENERAL - Section 44 - Seat Tracks	
<u>FUSELAGE FAIRING SKINS - SECTION 44</u>	53-40-70
IDENTIFICATION 1 - Section 44 - Wing-to-Body Fairing Skins	
ALLOWABLE DAMAGE GENERAL - Section 44 - Wing-to-Body Fairing Torque Tube Doors	
REPAIR GENERAL - Section 44 - Wing-to-Body Fairing Skins	
<u>FUSELAGE FAIRING STRUCTURE - SECTION 44</u>	53-40-71
IDENTIFICATION 1 - Section 44 - Fairing Structure	
ALLOWABLE DAMAGE GENERAL - Section 44 - Wing-to-Body Fairing Structure	
REPAIR GENERAL - Section 44 - Wing-to-Body Fairing Structure	
<u>FUSELAGE ATTACHMENT FITTINGS - SECTION 44</u>	53-40-90
REPAIR GENERAL - Section 44 - Main Landing Gear Wheel Well Fittings	
REPAIR 1 - Section 44 - Keel Beam Fittings	
<u>FUSELAGE SKINS - SECTION 46</u>	53-60-01
IDENTIFICATION 1 - Section 46 - Skins	
IDENTIFICATION 2 - Section 46 - Rain Gutter	
ALLOWABLE DAMAGE GENERAL - Section 46 - Skins	
REPAIR GENERAL - Section 46 - Skins	
<u>FUSELAGE STRINGERS - SECTION 46</u>	53-60-03
IDENTIFICATION 1 - Section 46 - Stringers	

53-CONTENTS



757-200
STRUCTURAL REPAIR MANUAL

CHAPTER 53
FUSELAGE

<u>SUBJECT</u>	<u>CHAPTER SECTION SUBJECT</u>
ALLOWABLE DAMAGE GENERAL - Section 46 - Stringers	
REPAIR GENERAL - Section 46 - Stringers	
<u>FUSELAGE INTERCOSTALS - SECTION 46</u>	53-60-04
IDENTIFICATION 1 - Section 46 - Intercostals	
ALLOWABLE DAMAGE GENERAL - Section 46 - Intercostals	
REPAIR GENERAL - Section 46 - Intercostals	
<u>FUSELAGE FRAMES - SECTION 46</u>	53-60-07
IDENTIFICATION 1 - Section 46 - Frames	
ALLOWABLE DAMAGE GENERAL - Section 46 - Frames	
REPAIR GENERAL - Section 46 - Frames	
<u>FUSELAGE BULKHEADS - SECTION 46</u>	53-60-08
IDENTIFICATION 1 - Section 46 - Bulkhead Structure	
<u>FUSELAGE KEEL STRUCTURE - SECTION 46</u>	53-60-12
IDENTIFICATION 1 - Section 46 - Keel Beam Structure	
ALLOWABLE DAMAGE 1 - Section 46 - Keel Beam Structure	
REPAIR GENERAL - Section 46 - Keel Chord Repair	
<u>CREASE BEAM - SECTION 46</u>	53-60-13
IDENTIFICATION 1 - Section 46 - Crease Beam	
ALLOWABLE DAMAGE 1 - Section 46 - Crease Beam	
ALLOWABLE DAMAGE 2 - Section 46 - Crease Beam - 757-SF	
<u>FUSELAGE DOOR SURROUND STRUCTURE - SECTION 46</u>	53-60-15
IDENTIFICATION 1 - Section 46 - Door Surround Structure	
ALLOWABLE DAMAGE 1 - Section 46 - Door Surround Structure	
ALLOWABLE DAMAGE 2 - Section 46 - Cargo Door Number 2 Lower Sill, Inboard Chord Stations 1378 - 1442	
REPAIR GENERAL - Door Surround Structure - Service Bulletin List	
REPAIR 1 - Section 46 - Door Surround Structure	

53-CONTENTS



757-200
STRUCTURAL REPAIR MANUAL

CHAPTER 53
FUSELAGE

<u>SUBJECT</u>	<u>CHAPTER SECTION SUBJECT</u>
<u>FUSELAGE FLOOR PANELS - SECTION 46</u>	53-60-50
IDENTIFICATION GENERAL - Section 46 - Main Deck Floor Panels	
ALLOWABLE DAMAGE GENERAL - Section 46 - Main Deck Floor Panels	
REPAIR GENERAL - Section 46 - Main Deck Floor Panels	
<u>FUSELAGE MAIN DECK FLOOR STRUCTURE - SECTION 46</u>	53-60-51
IDENTIFICATION 1 - Section 46 - Floor Structure	
ALLOWABLE DAMAGE GENERAL - Section 46 - Floor Structure	
REPAIR GENERAL - Section 46 - Main Deck Floor Structure	
REPAIR 1 - Section 46 - Floor Structure - Intercostal Upper Chord Repair Between Station 1661 and 1681.8	
REPAIR 2 - Section 46 - Aft Deck Plate	
<u>FUSELAGE SEAT TRACKS - SECTION 46</u>	53-60-52
IDENTIFICATION 1 - Section 46 - Seat Tracks	
ALLOWABLE DAMAGE GENERAL - Section 46 - Seat Tracks	
REPAIR GENERAL - Section 46 - Main Deck Seat Tracks	
<u>CARGO COMPARTMENT STRUCTURE - SECTION 46</u>	53-60-53
IDENTIFICATION 1 - Section 46 - Cargo Compartment Structure	
ALLOWABLE DAMAGE GENERAL - Section 46 - Cargo Compartment Floor Structure	
REPAIR GENERAL - Section 46 - Cargo Compartment Floor Structure	
<u>FUSELAGE FAIRING SKIN - SECTION 46</u>	53-60-70
IDENTIFICATION 1 - Section 46 - Wing-To-Body Fairing Skins	
IDENTIFICATION 2 - Dorsal Fin Skin	
ALLOWABLE DAMAGE GENERAL - Section 46 - Wing-to-Body Fairing Skins	
ALLOWABLE DAMAGE 1 - Dorsal Fin Skin	
REPAIR GENERAL - Section 46 Wing to Body Fairing Skin Repairs	
<u>FUSELAGE FAIRING STRUCTURE - SECTION 46</u>	53-60-71
IDENTIFICATION 1 - Section 46 - Wing-to-Body Fairing Structure	
IDENTIFICATION 2 - Dorsal Fin Structure	

53-CONTENTS



757-200
STRUCTURAL REPAIR MANUAL

CHAPTER 53
FUSELAGE

<u>SUBJECT</u>	<u>CHAPTER SECTION SUBJECT</u>
ALLOWABLE DAMAGE GENERAL - Section 46 Wing-to-Body Fairing Structure	
ALLOWABLE DAMAGE 1-Dorsal Fin Structure - Section 46	
REPAIR GENERAL - Section 46 - Wing-to-Body Fairing Structure	
REPAIR 1 - Section 46 - Wing-to-Body Fairing - Frame Support Angle	
<u>FUSELAGE SKINS - SECTION 48</u>	53-80-01
IDENTIFICATION 1 - Section 48 - Skins	
ALLOWABLE DAMAGE GENERAL - Section 48 - Skins	
REPAIR GENERAL - Section 48 - Skins	
<u>FUSELAGE STRUCTURE - SECTION 48</u>	53-80-02
IDENTIFICATION 1 - Section 48 - Stabilizer Jackscrew Support Fitting Structure	
ALLOWABLE DAMAGE GENERAL - Section 48 - Stabilizer Jackscrew Support Fitting Structure	
<u>FUSELAGE STRINGERS - SECTION 48</u>	53-80-03
IDENTIFICATION 1 - Section 48 - Stringers	
ALLOWABLE DAMAGE GENERAL - Section 48 - Stringers	
REPAIR GENERAL - Section 48 - Stringers	
<u>FUSELAGE INTERCOSTALS - SECTION 48</u>	53-80-04
IDENTIFICATION 1 - Section 48 - Intercostals	
ALLOWABLE DAMAGE GENERAL - Section 48 - Intercostals	
REPAIR GENERAL - Section 48 - Intercostal	
<u>FUSELAGE LONGERONS - SECTION 48</u>	53-80-05
IDENTIFICATION 1 - Section 48 - Longerons	
IDENTIFICATION 2 - Section 48 - APU Door Support Longeron	
ALLOWABLE DAMAGE 1 - Section 48 - Longerons	
<u>FUSELAGE FRAMES - SECTION 48</u>	53-80-07
IDENTIFICATION 1 - Section 48 - Frames	
ALLOWABLE DAMAGE GENERAL - Section 48 - Frames	
REPAIR GENERAL - Section 48 - Frames	

53-CONTENTS



757-200
STRUCTURAL REPAIR MANUAL

CHAPTER 53
FUSELAGE

<u>SUBJECT</u>	<u>CHAPTER SECTION SUBJECT</u>
<u>FUSELAGE BULKHEADS - SECTION 48</u>	53-80-08
IDENTIFICATION 1 - Section 48 - Bulkheads	
ALLOWABLE DAMAGE 1 - Section 48 - Bulkheads	
REPAIR GENERAL - Service Bulletin Repair Chart	
REPAIR 1 - Aft Pressure Bulkhead Lower Web and Chord Repair	
REPAIR 2 - APU Firewall Web Crack Repair Between Stiffeners	
REPAIR 3 - APU Firewall Web Crack Repair at a Stiffener	
<u>FUSELAGE BEAMS - SECTION 48</u>	53-80-13
IDENTIFICATION 1 - Section 48 - Beams	
ALLOWABLE DAMAGE 1 - Section 48 - Beams	
<u>FUSELAGE AUXILIARY STRUCTURE - SECTION 48</u>	53-80-30
IDENTIFICATION 1 - APU Plenum	
ALLOWABLE DAMAGE 1 - APU Plenum	
REPAIR GENERAL - Service Bulletin Repair Chart	
<u>AUXILIARY POWER UNIT AIR INLET DOOR - SECTION 48</u>	53-80-31
IDENTIFICATION 1 - Auxiliary Power Unit Air Inlet Door	
ALLOWABLE DAMAGE 1 - Auxiliary Power Unit Air Inlet Door	
REPAIR 1 - Acoustic Liner Damage Between 0.5 Inches and 3.0 Inches in Diameter	
REPAIR 2 - Acoustic Liner Damage Larger Than 3.0 Inches in Diameter	
REPAIR 3 - Acoustic Liner and Acoustic Core Damage Between 0.5 Inches and 3.0 Inches in Diameter	
REPAIR 4 - Acoustic Liner or Acoustic Core Damage Less Than 0.5 Inches in Diameter	
<u>FUSELAGE FAIRING SKIN - SECTION 48</u>	53-80-70
IDENTIFICATION 1 - Section 48 - Seal Fairing Skin	
ALLOWABLE DAMAGE 1 - Section 48 - Seal Fairing Skin	
<u>FUSELAGE FAIRING STRUCTURE - SECTION 48</u>	53-80-71
IDENTIFICATION 1 - Section 48 - Seal Fairing Structure	

53-CONTENTS



757-200
STRUCTURAL REPAIR MANUAL

CHAPTER 53
FUSELAGE

CHAPTER
SECTION
SUBJECT

SUBJECT

FUSELAGE ATTACHMENT FITTINGS - SECTION 48

53-80-90

IDENTIFICATION 1 - Section 48 - Attachment Fittings

ALLOWABLE DAMAGE GENERAL - Section 48 - Attachment Fittings

REPAIR GENERAL - Section 48 - Attachment Fittings

53-CONTENTS

Page 14
May 20/2008

D634N201



**757-200
STRUCTURAL REPAIR MANUAL**

GENERAL - FUSELAGE

1. General

- A. This chapter contains information concerning the structural components of the entire fuselage.
- B. Materials of these structural components, are tabulated. Their locations and arrangement are shown by illustrations. The pressurized areas are shown in Figure 2/GENERAL.
- C. Allowable damage to structural components is defined and illustrated in each section of the chapter.
- D. Typical repairs with instructions and illustrations are included in the chapter.
- E. In some instances, the term "body" has been used in place of "fuselage" to avoid conflict with manufacturing drawings. In particular, fore and aft locations on the fuselage are given by "body stations," and spanwise locations by "body buttock lines."
- F. Sealing procedure of structural repairs in the pressurized sections of the fuselage is indicated in 51-20-05, GENERAL.
- G. Leakage tests should be carried out as detailed in Chapter 5 of the Maintenance Manual after making the following repairs.
 - (1) Repairs involving several frames and/or bulkheads and adjacent skin panels.
 - (2) Repairs or replacement of structure adjacent to main entry door, cargo doors, emergency hatches, or galley door.
 - (3) Repairs to main entry doors, cargo doors, galley door, or emergency hatches.

2. References

Reference	Title
51-20-05, GENERAL	Repair Sealing

3. Applicability to modified airplanes

- A. The data in this section is applicable to 757 airplanes and 757 airplanes with Boeing modification only. Modifications that have been done independently of Boeing are not covered in this manual.
- B. Reference to "757-SF" airplanes refers to 757-200 airplanes modified to the Special Freighter configuration by The Boeing Company. These airplanes are listed in Table 1/GENERAL. Unless otherwise noted, reference to "757-200" includes Special Freighter airplanes.

Table 1: 757-200 Special freighter aircraft modified by Boeing.

Model-Series	Operator		Manufacturer			Registration number
	Identification code	Effectivity Code	Block Number	Serial number	Line Number	
757-236	NA201	001	N0009	22172	9	OO-DLN
757-236	NA202	002	N0010	22173	10	OO-DPF
757-236	NA203	003	N0011	22174	11	G-BIKC
757-236	NA204	004	N0013	22175	13	OO-DLQ
757-236	NA206	006	N0016	22177	16	G-BIKF
757-236	NA207	007	N0023	22178	23	G-BIKG
757-236	NA208	008	N0024	22179	24	OO-DLP
757-236	NA209	009	N0025	22180	25	G-BIKI



757-200 STRUCTURAL REPAIR MANUAL

Table 1: 757-200 Special freighter aircraft modified by Boeing. (Continued)

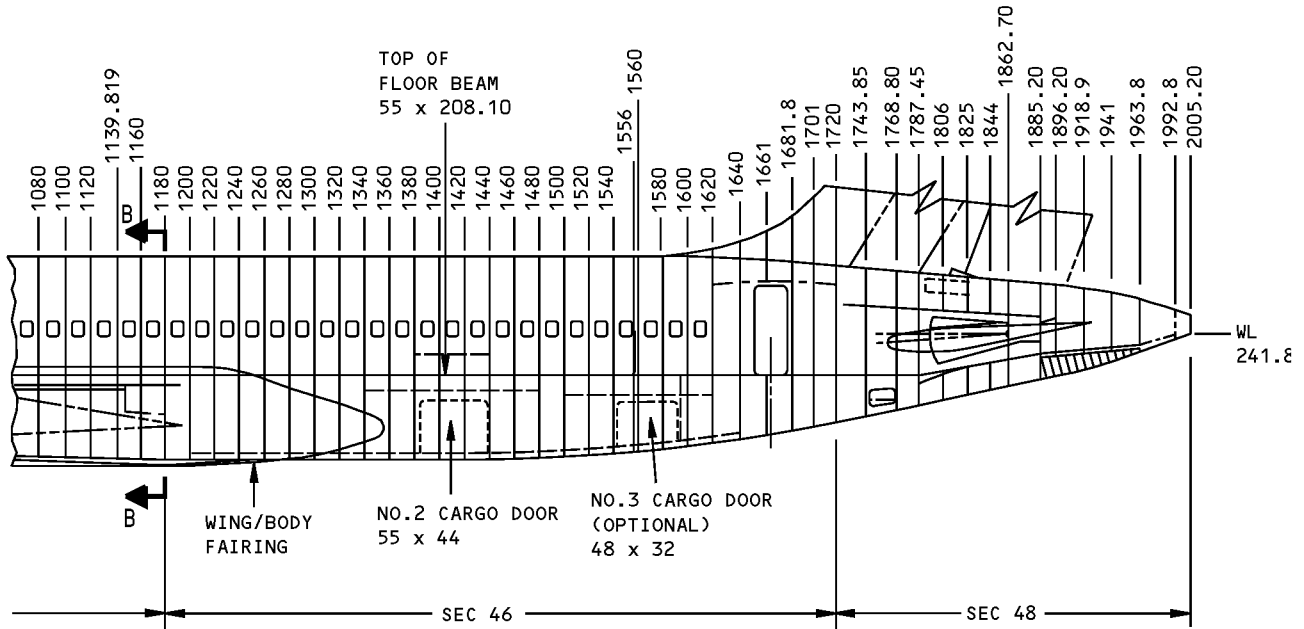
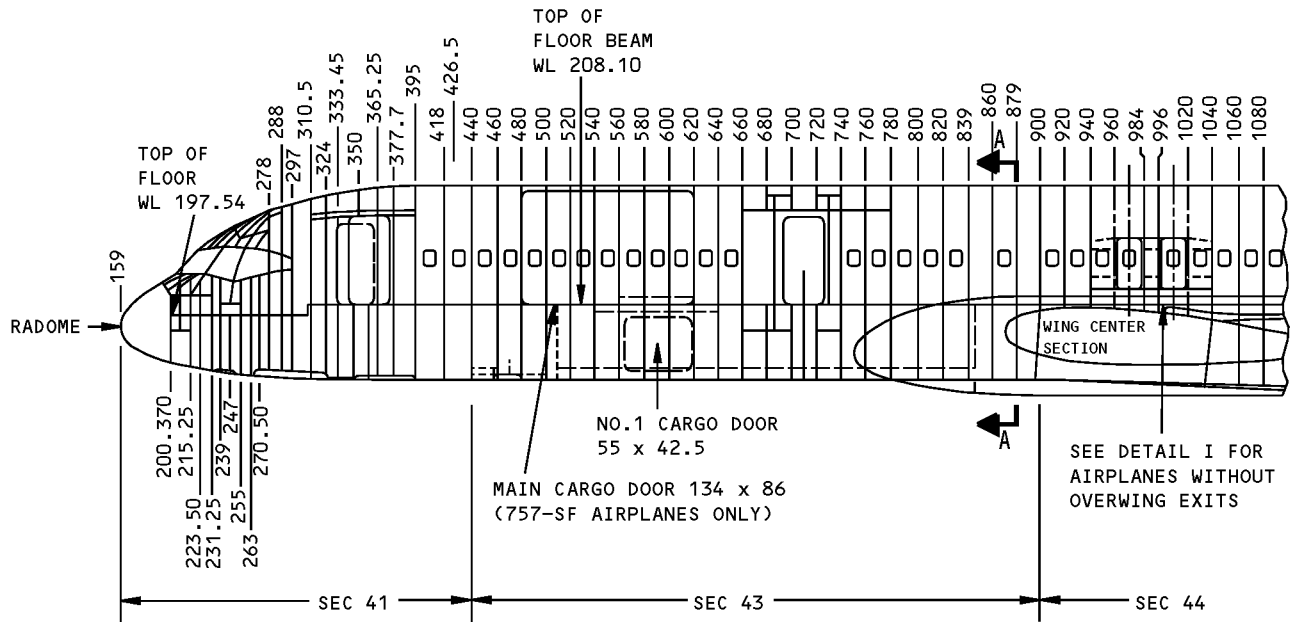
Model-Series	Operator		Manufacturer			Registration number
	Identification code	Effectivity Code	Block Number	Serial number	Line Number	
757-236	NA210	010	N0029	22181	29	G-BIKJ
757-236	NA211	011	N0030	22182	30	G-BIKK
757-236	NA212	012	N0032	22183	32	OO-DPB
757-236	NA213	013	N0033	22184	33	G-BIKM
757-236	NA215	015	N0040	22186	50	G-BIKN
757-236	NA216	016	N0042	22187	52	G-BIKO
757-236	NA217	017	N0044	22188	54	G-BIKP
757-236	NA218	018	N0048	22189	58	OO-DPM
757-236	NA219	019	N0052	22190	63	G-BIKS
757-236	NA220	020	N0061	23398	77	OO-DPO
757-236	NA221	021	N0062	23399	78	G-BIKU
757-236	NA222	022	N0065	23400	81	G-BIKV
757-236	NA223	023	N0070	23492	89	OO-DPK
757-236	NA224	024	N0071	23493	90	OO-DPJ
757-236	NA225	025	N0072	23533	93	OO-DPN
757-236	NA226	026	N0076	23532	98	G-BIKZ
757-236	NA227	027	N0095	23710	123	G-BMRA
757-236	NA228	028	N0106	23975	145	G-BMRB
757-236	NA229	029	N0113	24072	160	G-BMRC
757-236	NA230	030	N0118	24073	166	G-BMRD
757-236	NA231	031	N0120	24074	168	G-BMRE
757-236	NA232	032	N0126	24101	175	G-BMRF
757-236	NA233	033	N0128	24102	179	OO-DPI
757-236	NA234	034	N0142	24266	210	G-BMRH
757-236	NA235	035	N0143	24267	211	OO-DPL
757-236	NA236	036	N0146	24268	214	G-BMRJ

4. Testing

- A. Proof pressure testing of an extensively damaged fuselage after repair is beneficial to the fatigue life of the structure as a pressure vessel.
- B. Care in installation and sealing when carrying out repairs or replacements in the pressurized region of the fuselage will minimize the risk of leaks. Normally a check for excessive leakage rates may be made during flight test after repair.
- C. Where excessive leakage rates occur or where it is desired to make a leakage test on the ground, reference should be made to Chapter 5 of the Maintenance Manual.

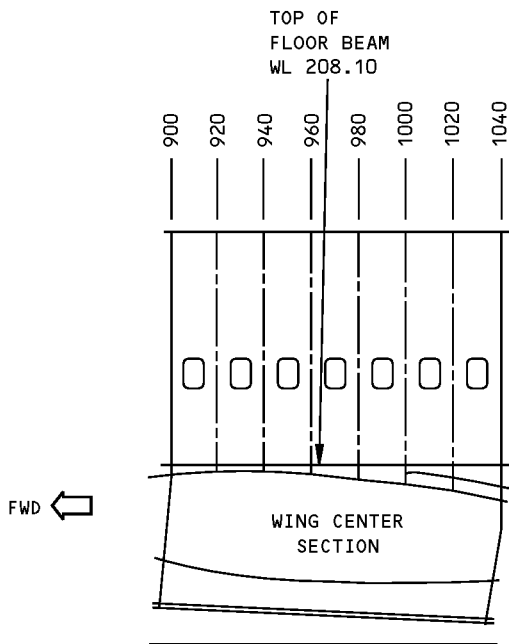
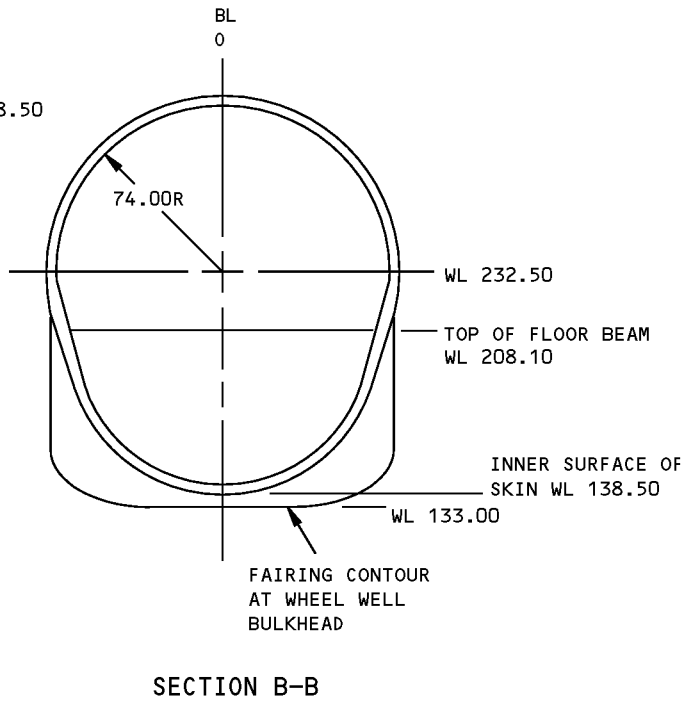
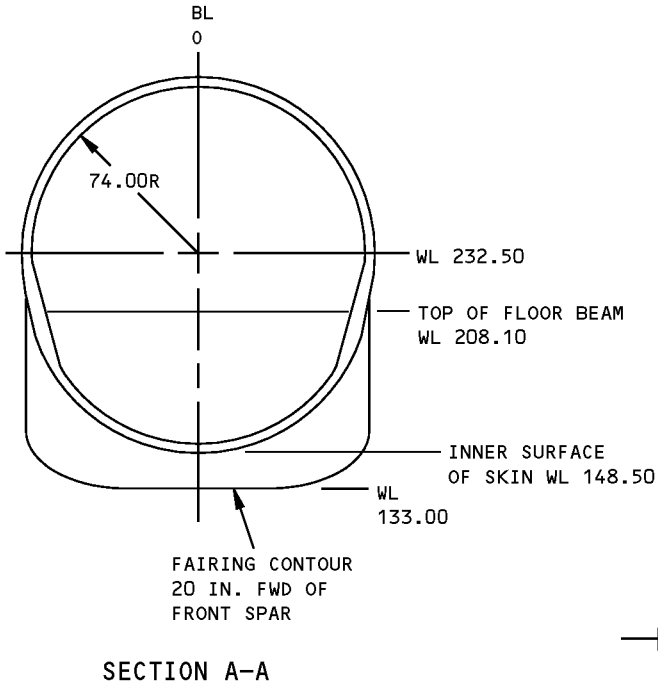
**757-200
STRUCTURAL REPAIR MANUAL**

REF DWG
140N1510



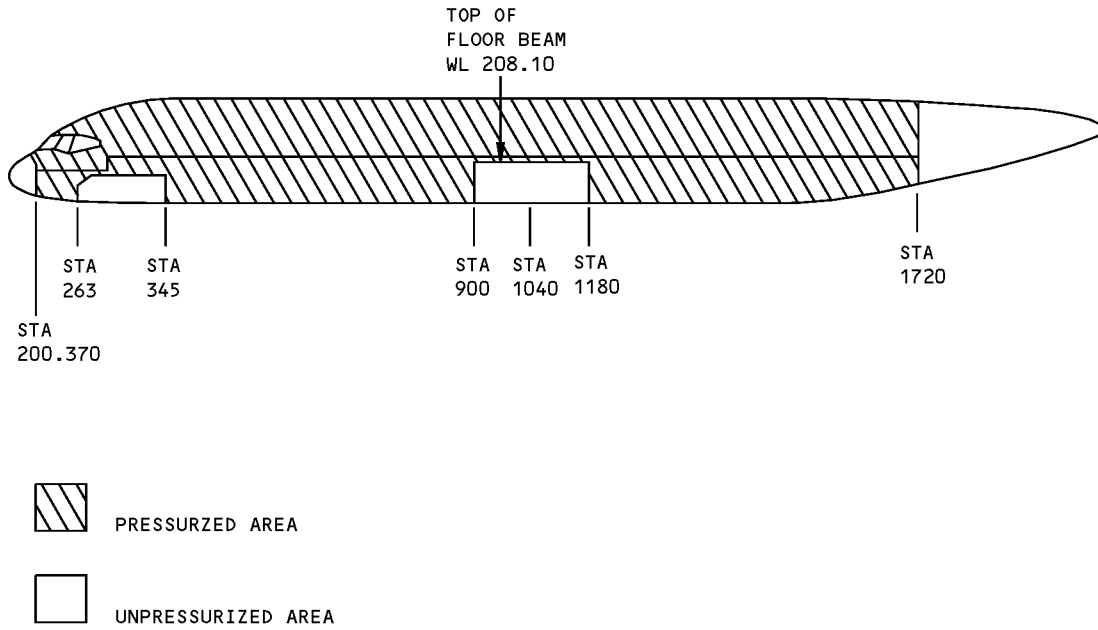
**Fuselage Station Diagram
Figure 1 (Sheet 1 of 2)**

**757-200
STRUCTURAL REPAIR MANUAL**



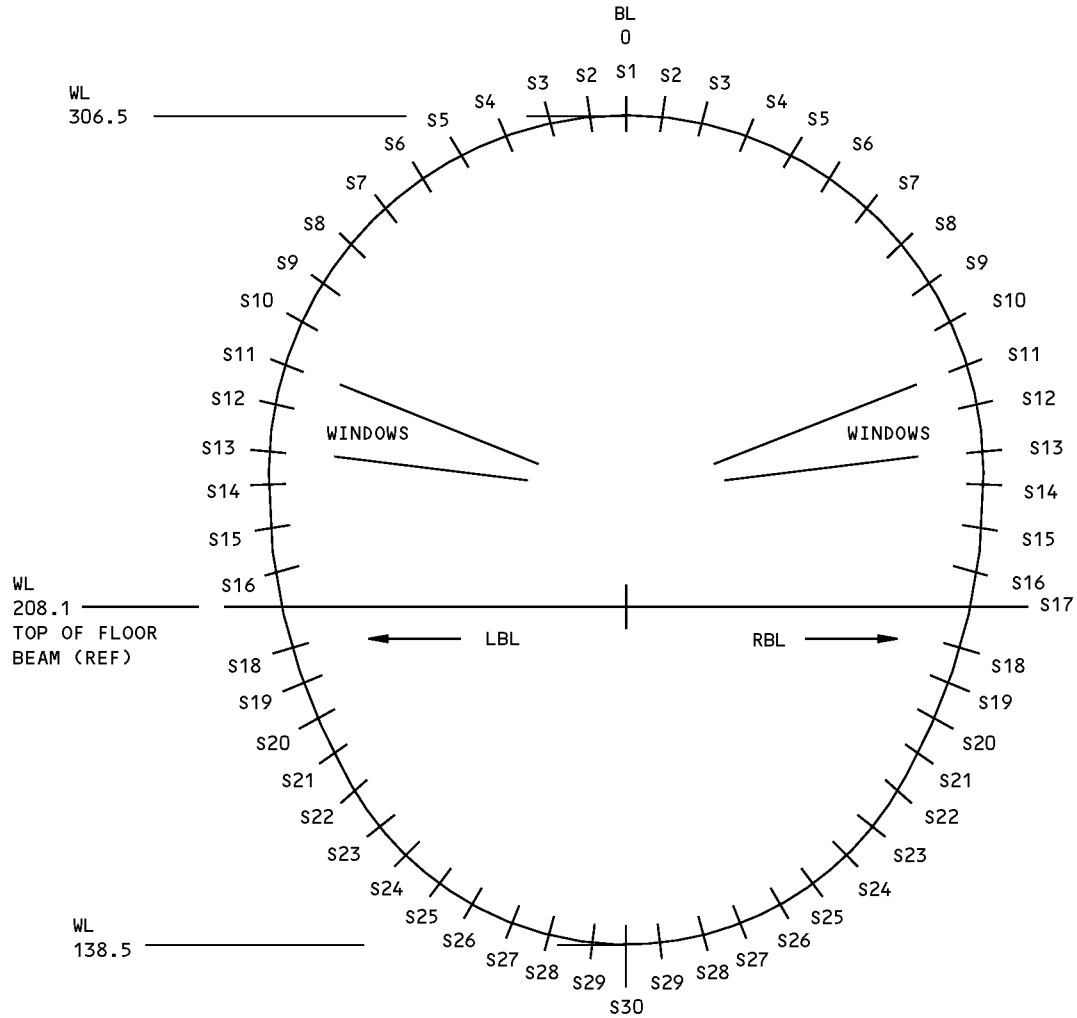
**Fuselage Station Diagram
Figure 1 (Sheet 2 of 2)**

**757-200
STRUCTURAL REPAIR MANUAL**



**Pressurized Area Diagram
Figure 2**

**757-200
STRUCTURAL REPAIR MANUAL**



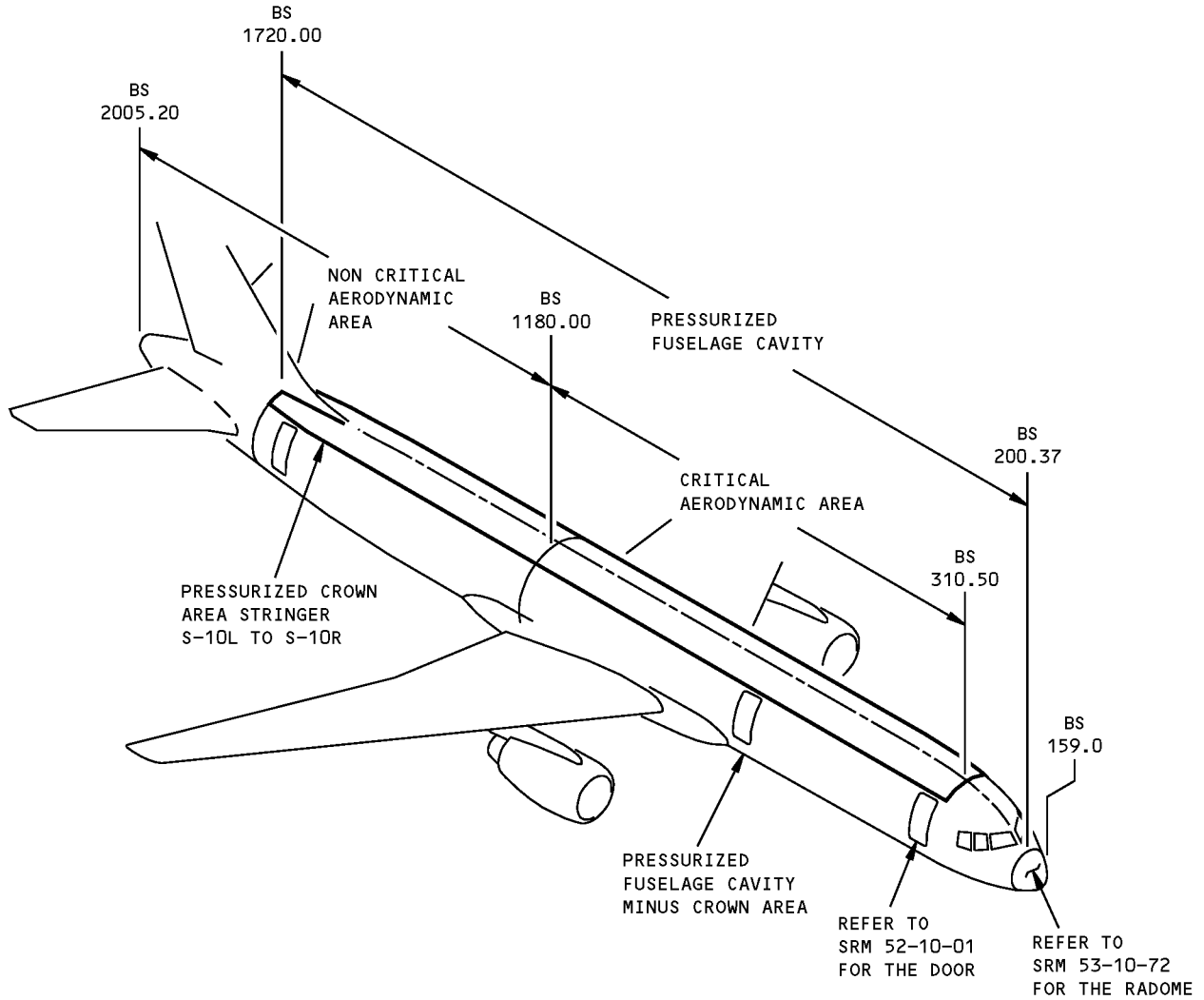
**STRINGER DIAGRAM
VIEW LOOKING FORWARD
SECTION 46**

**Fuselage Stringer Diagram
Figure 3**

**757-200
STRUCTURAL REPAIR MANUAL**

ALLOWABLE DAMAGE 1 - FUSELAGE SKIN

REFERENCE DRAWING
140N1580



**Fuselage Skin Allowable Damage
Figure 101 (Sheet 1 of 6)**



757-200

STRUCTURAL REPAIR MANUAL

AREA	CRACKS [C]	NICKS, GOUGES, SCRATCHES AND CORROSION [C]	DENTS [K]	HOLES	WRINKLES OR BUCKLES
THE PRESSURIZED FUSELAGE SKIN MINUS THE CROWN (S10L-S10R)	FOR EDGE CRACKS SEE DETAIL I [A]. OTHER CRACKS ARE NOT PERMITTED.	FOR EDGE DAMAGE SEE DETAIL I [A]. FOR DAMAGE IN THE LONGITUDINAL LAP SPLICES SEE DETAIL IV [D]. FOR OTHER DAMAGE SEE DETAIL II [D].	SEE DETAIL III [B] [F] [I] [J]	NOT PERMITTED	[B] [H]
THE PRESSURIZED FUSELAGE CROWN SKIN (S10L-S10R)	FOR EDGE CRACKS SEE DETAIL I [A]. OTHER CRACKS ARE NOT PERMITTED.	FOR EDGE DAMAGE SEE DETAIL I [A]. FOR DAMAGE IN THE LONGITUDINAL LAP SPLICES SEE DETAIL IV [E]. FOR DAMAGE IN THE CIRCUMFERENTIAL BUTT SPLICE SEE DETAIL V. FOR OTHER DAMAGE SEE DETAIL II [E].	SEE DETAIL III [B] [I] [J]	NOT PERMITTED	[B]
SECTION 48 FUSELAGE SKIN FROM BS 1720.00 TO BS 1896.20. FOR THE ALLOWABLE DAMAGE OF THE HONEYCOMB SKIN PANELS IN SECTION 48 BETWEEN BS 1896.20 AND BS 1992.8, REFER TO SRM 53-80-01.	FOR EDGE CRACKS SEE DETAIL I. OTHER CRACKS ARE NOT PERMITTED.	FOR EDGE DAMAGE SEE DETAIL I. FOR OTHER DAMAGE SEE DETAIL II [D].	SEE DETAIL III [B] [I] [J]	[G]	[B]

Fuselage Skin Allowable Damage
Figure 101 (Sheet 2 of 6)

ALLOWABLE DAMAGE 1

53-00-01

Page 102
May 20/2006

D634N201

STRUCTURAL REPAIR MANUAL

NOTES

- THIS ALLOWABLE DAMAGE IS A CATEGORY A REPAIR FOR 757-SF AIRPLANES. THE INSPECTIONS GIVEN IN THE MAINTENANCE PLANNING DATA (MPD) AND ASSOCIATED SUPPLEMENT ARE SUFFICIENT TO MAINTAIN THE DAMAGE TOLERANCE OF THE INITIAL STRUCTURE WITH THIS ALLOWABLE DAMAGE. REFER TO SRM 51-00-06 FOR REPAIR CATEGORIES AND DEFINITIONS.
- REFER TO SRM 51-10-02 FOR INSPECTION AND REMOVAL OF DAMAGE.
- REFINISH REWORKED AREAS AS GIVEN IN AMM 51-20.
- FINISH ALL REWORKED EDGES AND SURFACES TO 63 MICROINCHES Ra OR BETTER.

- A** EDGE GAPS MUST BE FILLED WITH AERODYNAMIC SMOOTHER AS SHOWN IN AMM 51-10-01 FORWARD OF BS 1180.00.
- B** REFER TO SRM 51-10-01 FOR AERODYNAMIC SMOOTHNESS REQUIREMENTS.
- C** REFER TO ALLOWABLE DAMAGE 2 FOR THE FUSELAGE SKIN OPERATING LIMITS AFTER THE DAMAGE HAS BEEN REMOVED.
- D** MAXIMUM ALLOWABLE CROSS SECTION AREA REMOVED INCLUDING ALL INITIAL HOLES IS NOT MORE THAN 15 PERCENT OF THE TOTAL CROSS SECTIONAL AREA IN ANY LOCAL REGION.
- E** MAXIMUM ALLOWABLE CROSS SECTION AREA REMOVED INCLUDING ALL INITIAL HOLES IS NOT MORE THAN 10 PERCENT OF THE TOTAL CROSS SECTIONAL AREA IN ANY LOCAL REGION.
- F** REFER TO SRM 51-10-01 FOR LIMITATIONS IN THE VICINITY OF THE STATIC PORT.
- G** HOLES CLEANED UP TO 0.25 INCH (6 mm) DIAMETER ARE PERMITTED. FILL HOLE WITH A 2117 PROTRUDING HEAD RIVET.
- H** IT IS NORMAL TO FIND LIGHT SKIN WRINKLES OR BUCKLING IN THE LOWER AFT FUSELAGE, EXCEPT LOCALLY AROUND CUTOUTS.

THE WRINKLES ARE CONSIDERED TO BE NORMAL UNLESS THERE IS EVIDENCE OF CRACKING, LOOSE OR DAMAGED FASTENERS, SHARP CREASES, OR WRINKLING THAT EXTENDS INTO OR BEYOND FASTENER ROWS. FUSELAGE SKINS WITH EVIDENCE OF CRACKING, LOOSE OR DAMAGED FASTENERS, SHARP CREASES, OR WRINKLING THAT EXTENDS INTO OR BEYOND FASTENER ROWS MUST BE REPAIRED, AND ADJACENT STRUCTURE MUST BE INSPECTED FOR DAMAGE AS SPECIFIED IN AMM 05-51.

- I** NO REPAIRS OR SPECIAL INSPECTIONS ARE NECESSARY FOR DENTS THAT MEET THE LIMITS SHOWN IN DETAIL III. HOWEVER, REFER TO SRM 51-70-01 FOR THE REPAIR OF MINOR DENTS IN SHEET METAL MATERIALS IF IMPROVED APPEARANCE OR AERODYNAMIC SMOOTHNESS IS NECESSARY.

CAUTION: DO NOT FILL THE DENTS WHICH ARE MORE THAN THE LIMITS SHOWN IN DETAIL III.

DENTS THAT DO NOT MEET THE LIMITS SHOWN IN DETAIL III SHOULD BE PERMANENTLY REPAIRED (REFER TO SRM 53-00-01 REPAIR 2, 3, 4, 5, 7, OR 8). HOWEVER, A REPAIR CAN BE DELAYED IF THE CONDITIONS THAT FOLLOW ARE MET:

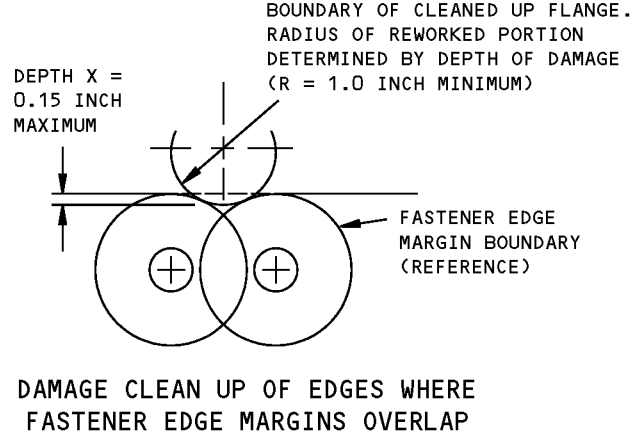
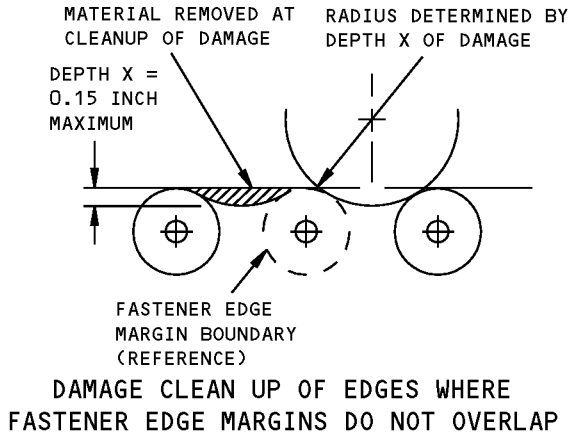
- DENTS MUST MEET ALL THE LIMITS SHOWN IN DETAIL III EXCEPT THE DEPTH CAN BE GREATER THAN 0.125 AND/OR THE A/Y RATIO CAN BE LESS THAN 30.
- AN EXAMINATION OF THE DENT IS MADE EVERY 300 FLIGHT CYCLES.
- A PERMANENT REPAIR IS MADE AT OR BEFORE THE NEXT C-CHECK, NOT TO EXCEED 24 MONTHS.

- J** IF A DENT IS WITHIN THE LIMITS OF DETAIL III BUT MORE THAN THE WAVINESS LIMIT SHOWN IN SRM 51-10-01, FIGURE 3, SUBSEQUENT FLIGHTS ARE PERMITTED BUT A LOSS OF AERODYNAMIC PERFORMANCE WILL OCCUR

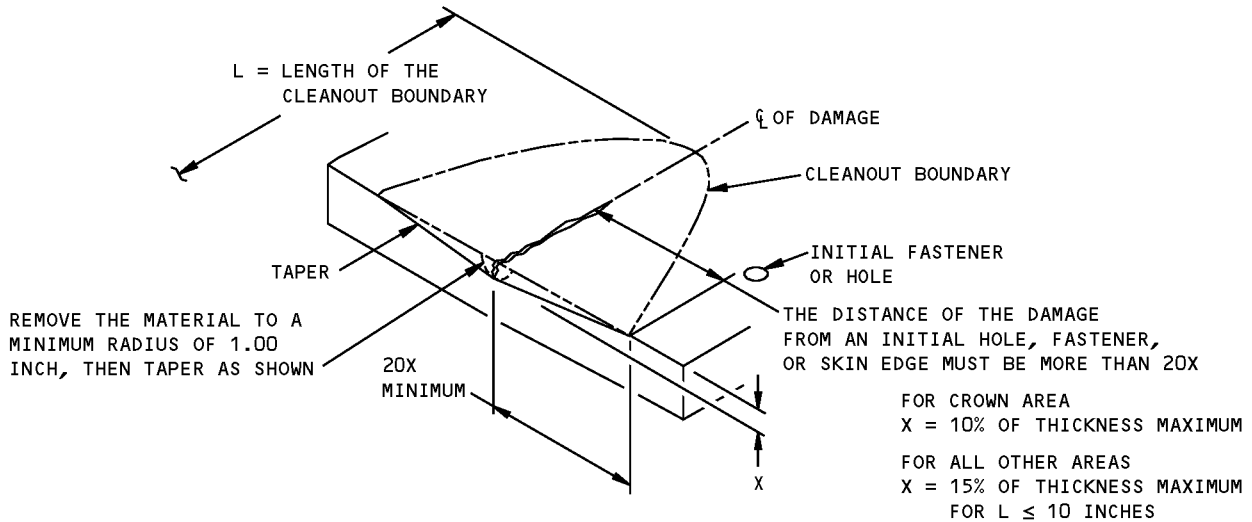
- K** THE INSPECTION GIVEN IN THE MAINTENANCE PLANNING DATA (MPD) MANUAL ARE SUFFICIENT TO MAINTAIN THE DAMAGE TOLERANCE OF THE INITIAL STRUCTURE WITH THIS ALLOWABLE DAMAGE.

**Fuselage Skin Allowable Damage
Figure 101 (Sheet 3 of 6)**

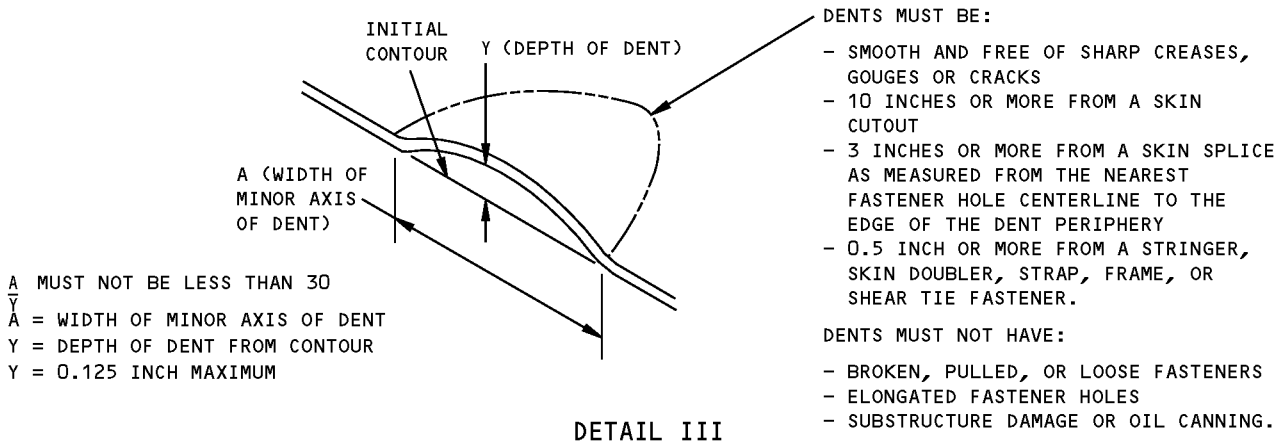
STRUCTURAL REPAIR MANUAL



DETAIL I



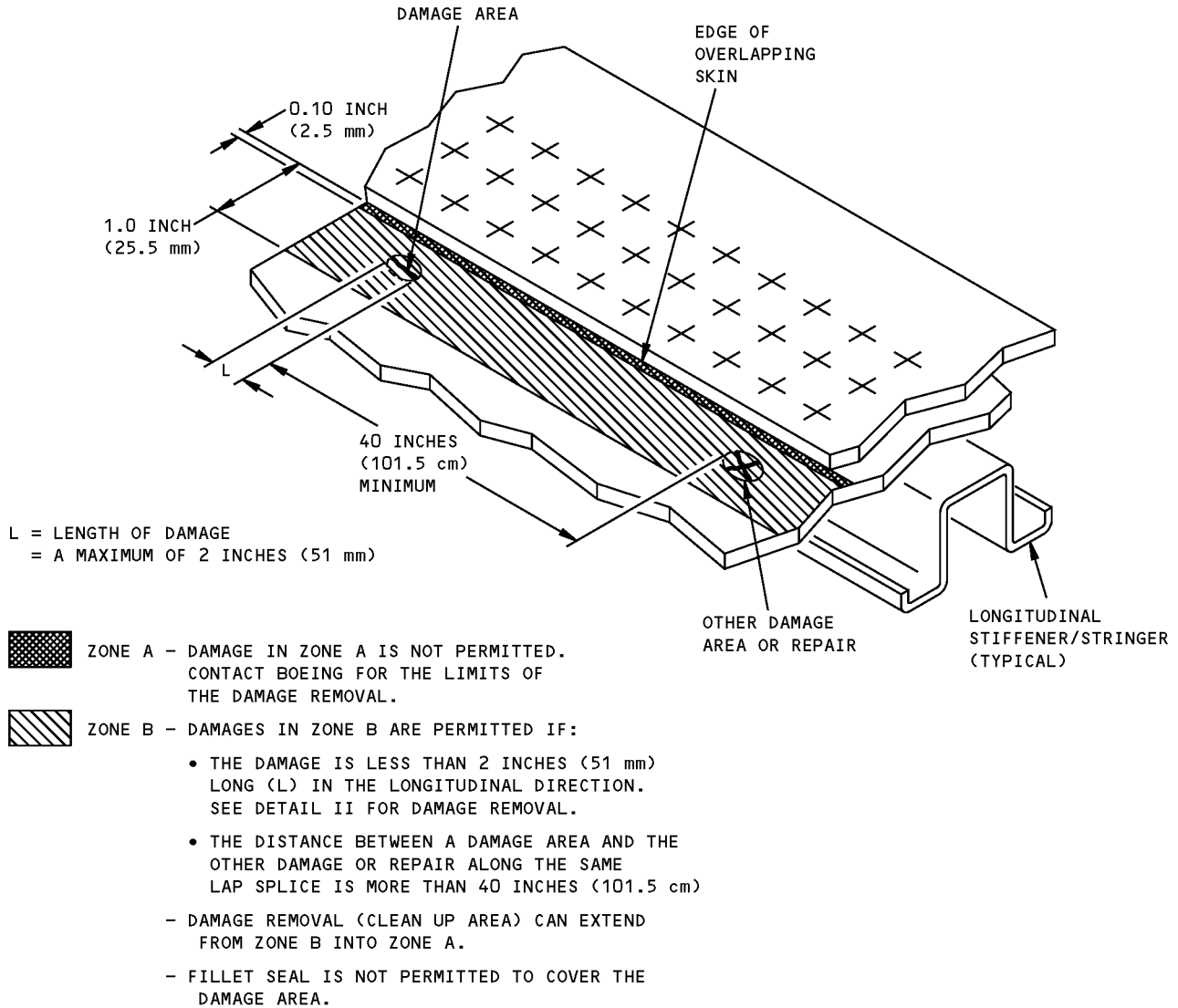
REMOVAL OF NICK, GOUGE, CORROSION, AND SCRATCH DAMAGE ON A SURFACE
DETAIL II



DETAIL III

Fuselage Skin Allowable Damage
Figure 101 (Sheet 4 of 6)

**757-200
STRUCTURAL REPAIR MANUAL**



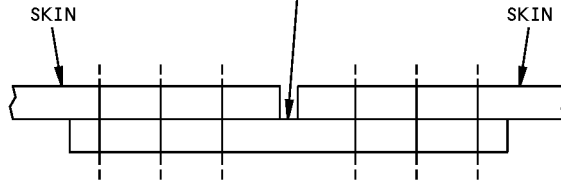
**DAMAGE AT THE LONGITUDINAL LAP SPLICE
DETAIL IV**

**Fuselage Skin Allowable Damage
Figure 101 (Sheet 5 of 6)**

757-200
STRUCTURAL REPAIR MANUAL

REWORK IS NOT PERMITTED ALONG THE
CIRCUMFERENTIAL BUTT SPLICE STRAP,
BETWEEN SKIN EDGES.

CONTACT BOEING FOR ALLOWABLE
DAMAGE IN THIS AREA

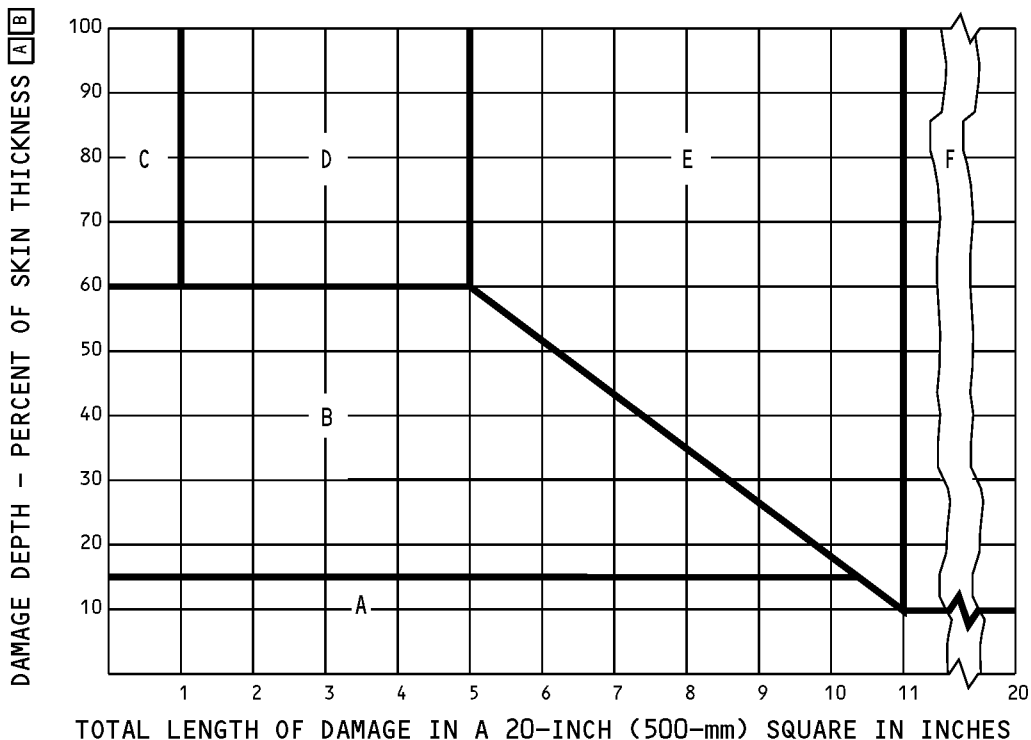


DAMAGE AT THE CIRCUMFERENTIAL BUTT SPLICE
DETAIL V

Fuselage Skin Allowable Damage
Figure 101 (Sheet 6 of 6)

**757-200
STRUCTURAL REPAIR MANUAL**

ALLOWABLE DAMAGE 2 - OPERATING LIMITS FOR FUSELAGE SKIN



NOTES

- SEE ALLOWABLE DAMAGE 1, DETAIL II FOR CROWN AREA RESTRICTIONS
- THIS ALLOWABLE DAMAGE IS A CATEGORY A REPAIR FOR 757-SF AIRPLANES. THE INSPECTIONS GIVEN IN THE MAINTENANCE PLANNING DATA (MPD) AND ASSOCIATED SUPPLEMENT ARE SUFFICIENT TO MAINTAIN THE DAMAGE TOLERANCE OF THE INITIAL STRUCTURE WITH THIS ALLOWABLE DAMAGE. REFER TO SRM 51-00-06 FOR REPAIR CATEGORIES AND DEFINITIONS. THIS CATEGORY A REPAIR CLASSIFICATION IS APPLICABLE TO CHART AREA A ONLY, FOR DAMAGE OUTSIDE THE CROWN AREA.

- A** THE PERCENT OF SKIN THICKNESS IS CALCULATED FROM THE NOMINAL THICKNESS GIVEN ON THE PRODUCTION DRAWING FOR THE SKIN.
SKIN THICKNESS DOES NOT INCLUDE THE THICKNESS OF THE DOUBLERS, TRIPLERS, OR STRAPS.
- B** DAMAGE INCLUDES HOLES, PUNCTURES, NICKS, GOUGES, SCRATCHES, CORROSION AND CRACKS.
DAMAGE DOES NOT INCLUDE DENTS.
- C** CABIN PRESSURE LIMITS ARE FOR SKIN DAMAGE IN THE PRESSURIZED FUSELAGE CAVITY ONLY.

**Operating Limits for Fuselage Skin
Figure 101 (Sheet 1 of 2)**



757-200

STRUCTURAL REPAIR MANUAL

CHART AREA	DAMAGE TREATMENT	ALLOWABLE AIRPLANE OPERATIONS
A	CLEAN UP AS SHOWN IN ALLOWABLE DAMAGE 1.	NO FLIGHT RESTRICTIONS.
B	CLEAN UP AS SHOWN IN ALLOWABLE DAMAGE 1 TO DAMAGE DEPTH.	LIMITED TO 50 HOURS OF FLIGHT OR 25 FLIGHTS, WHICHEVER COMES FIRST (INCLUDING REVENUE FLIGHTS).
	DO AN APPLICABLE REPAIR AS GIVEN IN SRM 53-00-01.	REFER TO THE APPLICABLE REPAIR FOR THE LIMITS.
C	CLEAN UP AS SHOWN IN ALLOWABLE DAMAGE 1 TO DAMAGE DEPTH. STOP DRILL 0.25 INCH (6.35 mm) DIAMETER HOLES AT THE ENDS OF THE CRACKS.	A NON-REVENUE FLIGHT TO A REPAIR STATION IS PERMITTED IF THE APPLICABLE REGULATORY AUTHORITY GIVES APPROVAL BEFORE THE FLIGHT. IT IS RECOMMENDED THAT THE PROPOSED REPAIR PROCEDURE BE PROVIDED TO BOEING. THE MAXIMUM CABIN PRESSURE DIFFERENTIAL LIMITED C TO 6.0 PSIG (41.4 KPAG) UNLESS REPAIRED.
	DO AN APPLICABLE REPAIR AS GIVEN IN SRM 53-00-01.	REFER TO THE APPLICABLE REPAIR FOR THE LIMITS.
D	CLEAN UP AS SHOWN IN ALLOWABLE DAMAGE 1 TO DAMAGE DEPTH. STOP DRILL 0.25 INCH (6.35 mm) DIAMETER HOLES AT THE ENDS OF THE CRACKS.	A NON-REVENUE FLIGHT TO A REPAIR STATION IS PERMITTED IF THE APPLICABLE REGULATORY AUTHORITY GIVES APPROVAL BEFORE THE FLIGHT. IT IS RECOMMENDED THAT THE PROPOSED REPAIR PROCEDURE BE PROVIDED TO BOEING. THE MAXIMUM CABIN PRESSURE DIFFERENTIAL LIMITED C TO 6.0 PSIG (41.4 KPAG) UNLESS REPAIRED.
	DO AN APPLICABLE REPAIR AS GIVEN IN SRM 53-00-01.	REFER TO THE APPLICABLE REPAIR FOR THE LIMITS.
E	CLEAN UP AS SHOWN IN ALLOWABLE DAMAGE 1 TO DAMAGE DEPTH. STOP DRILL 0.25 INCH (6.35 mm) DIAMETER HOLES AT THE ENDS OF THE CRACKS.	A NON-REVENUE FLIGHT TO A REPAIR STATION IS PERMITTED IF THE APPLICABLE REGULATORY AUTHORITY GIVES APPROVAL BEFORE THE FLIGHT. IT IS RECOMMENDED THAT THE PROPOSED REPAIR PROCEDURE BE PROVIDED TO BOEING. THE MAXIMUM CABIN PRESSURE DIFFERENTIAL LIMITED C IS NOT MORE THAN ZERO PSIG (ZERO KPAG).
	DO AN APPLICABLE REPAIR AS GIVEN IN SRM 53-00-01.	REFER TO THE APPLICABLE REPAIR FOR THE LIMITS.
F	CLEAN UP AS SHOWN IN ALLOWABLE DAMAGE 1 TO DAMAGE DEPTH. STOP DRILL 0.25 INCH (6.35 mm) DIAMETER HOLES AT ENDS OF THE CRACKS.	OPERATION IS NOT PERMITTED BEFORE BOEING AND THE APPLICABLE REGULATORY AUTHORITY GIVES APPROVAL.
	DO AN APPLICABLE REPAIR AS GIVEN IN SRM 53-00-01.	REFER TO THE APPLICABLE REPAIR FOR THE LIMITS.

LIMITS FOR CORROSION, CRACKS, NICKS, GOUGES, AND HOLE DAMAGE

Operating Limits for Fuselage Skin
Figure 101 (Sheet 2 of 2)

ALLOWABLE DAMAGE 2

53-00-01

Page 102
Jan 20/2005

D634N201



**757-200
STRUCTURAL REPAIR MANUAL**

REPAIR GENERAL - FUSELAGE SKIN - DEFINITION OF REPAIR ZONES AND SERVICE BULLETIN CHART

SERVICE BULLETIN REPAIRS

The following service bulletins contain Fuselage Skin repairs which are available for use where specific damage has been encountered. Usually, the service bulletin also covers preventive modification data which operators are encouraged to use to eliminate the need for repair.

DAMAGED AREA	CUM LINE NUMBER EFFECTIVITY A	SB NUMBER
FUSELAGE - INSPECTION AND REPAIR OF SHORT EDGE MARGINS IN TEARSTRAP END TABS	1 THRU 104	757-53-0043

A FOR AIRPLANES ON WHICH PREVENTIVE MODIFICATION HAS NOT BEEN ACCOMPLISHED

**Service Bulletin Repair Chart
Figure 201**

D634N201

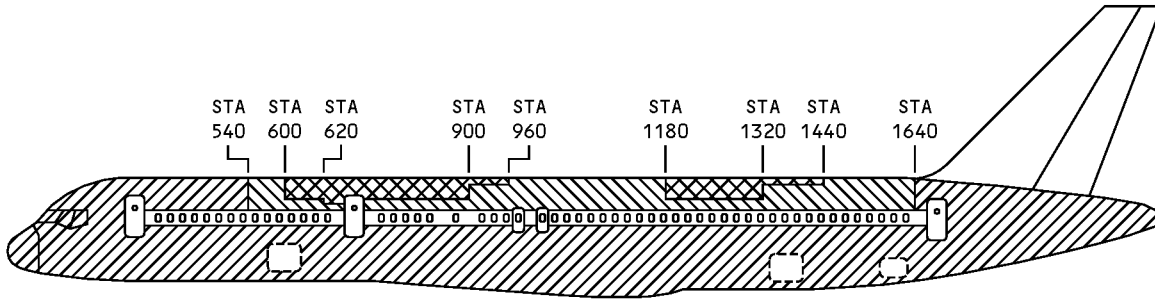
53-00-01




REPAIR GENERAL
Page 201
Jan 20/2005



757-200
STRUCTURAL REPAIR MANUAL

**757-200
STRUCTURAL REPAIR MANUAL**



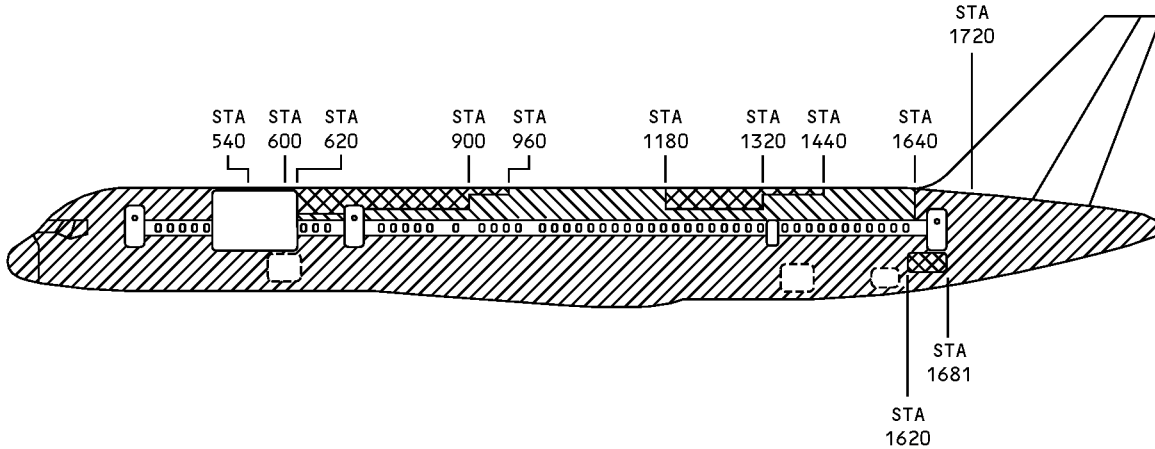
- 
ZONE A - FROM STA 192 TO STA 540 AND FROM STA 1640 TO THE TAIL CONE ANYWHERE IN THE FUSELAGE SKIN, AND FROM STA 540 TO STA 1640 BELOW STRINGER 13
- 
ZONE B - FROM STA 540 TO STA 1640 ABOVE THE WINDOW BELT FROM STRINGER 11L TO 11R EXCLUDING ZONE C
- 
ZONE C - BETWEEN STA 600 AND STA 900 FROM STRINGER 6L TO 6R; BETWEEN STA 620 AND STA 660 FROM STRINGERS 6L/6R TO 8L/8R; BETWEEN STA 900 AND STA 960 FROM STRINGERS 4L TO 4R, BETWEEN STA 1180 AND STA 1320 FROM STRINGER 6L TO 6R; BETWEEN STA 1320 AND STA 1440 FROM STRINGER 4L TO 4R

NOTES

- DEFINITION OF REPAIR ZONES APPLICABLE TO PASSENGER AIRPLANES ONLY

**Fuselage Skin - Definition of Repair Zones
Figure 202 (Sheet 1 of 2)**

**757-200
STRUCTURAL REPAIR MANUAL**



ZONE A - FROM STA 192 TO STA 540 AND FROM STA 1640 TO THE TAIL CONE ANYWHERE IN THE FUSELAGE SKIN, AND FROM STA 540 TO STA 1640 BELOW STRINGER 13



ZONE B - FROM STA 540 TO STA 1640 ABOVE THE WINDOW BELT FROM STRINGER 11L TO 11R EXCLUDING ZONE C



ZONE C - BETWEEN STA 600 AND STA 620 FROM STRINGER 3L TO 6R; BETWEEN STA 620 AND STA 900 FROM STRINGER 6L TO 6R; BETWEEN STA 620 AND STA 660 FROM STRINGERS 6L/6R TO 8L/8R; BETWEEN STA 900 AND STA 960 FROM STRINGERS 4L TO 4R, BETWEEN STA 1180 AND STA 1320 FROM STRINGER 6L TO 6R; BETWEEN STA 1320 AND STA 1440 FROM STRINGER 4L TO 4R; BETWEEN STA 1620 AND STA 1681 FROM STRINGER 20L TO 24L AND FROM STRINGER 20R TO 22R

NOTES

- DEFINITION OF REPAIR ZONES APPLICABLE TO 757-SF AIRPLANES ONLY

**Fuselage Skin - Definition of Repair Zones
Figure 202 (Sheet 2 of 2)**

STRUCTURAL REPAIR MANUAL**REPAIR 1 - METHOD OF USING BRILES RIVET HEAD AS REPAIR WASHER FOR EXTERNAL SKIN REPAIR****REPAIR INSTRUCTIONS**

1. Overdrive the existing Briles rivet button to a maximum diameter of 1.65D button diameter.
2. Centerpunch center of existing Briles manufactured rivet head.
3. Drill 1/8 inch pilot hole through the Briles rivet from the manufactured side.
4. Microshave the manufactured head to provide a flush surface for the doubler.
5. Locate repair doubler and drill all holes in new fastener locations.
6. Backdrill pilot holes through repair doubler from button side.
7. Drill or ream holes to final size and countersink for desired fastener on external side of repair doubler.
8. Remove chips and any remaining portion of the original rivet button and install fasteners.

NOTES

- THIS IS A TYPICAL PROCEDURE FOR INSTALLING AN EXTERNAL REPAIR PLATE OVER AREAS WHERE BRILES RIVETS (BACR15FV) WERE INSTALLED AT MANUFACTURE, THE EXISTING BRILES RIVET HEADS ARE USED AS REPAIR WASHERS IN THIS REPAIR PROCEDURE.
- FINISH THE REWORKED ARE PER 51-20 OF THE MAINTENANCE MANUAL.
- ALODIZE EDGES AND HOLES PER 51-10-02
- REFER TO 51-40-02 FOR RIVET INSTALLATION.

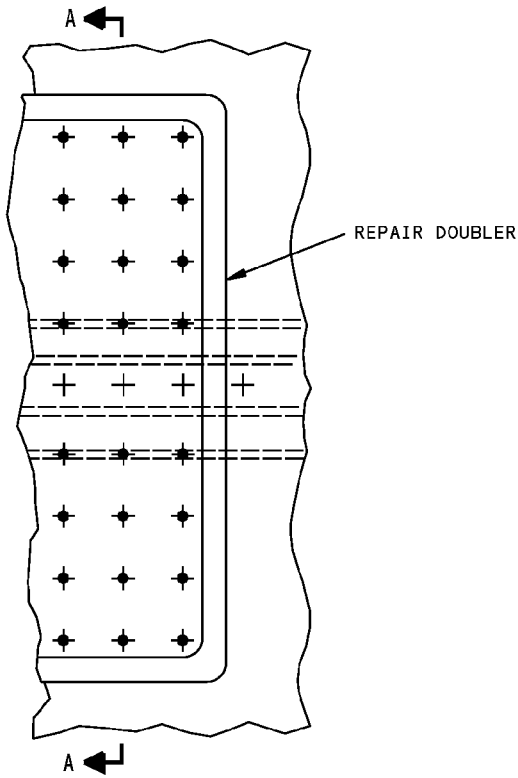
FASTENER SYMBOLS

+ EXISTING FASTENER LOCATIONS

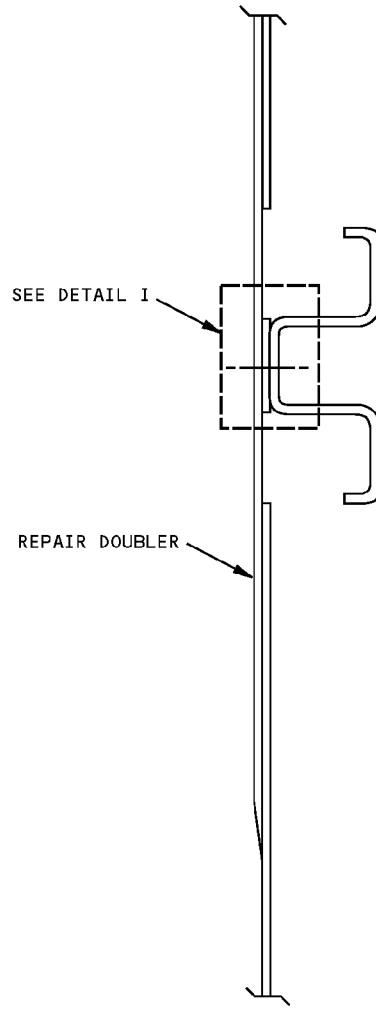
◆ NEW FASTENER LOCATIONS

**Method of Using Briles Rivet Head as Repair Washer for External Skin Repair
Figure 201 (Sheet 1 of 2)**

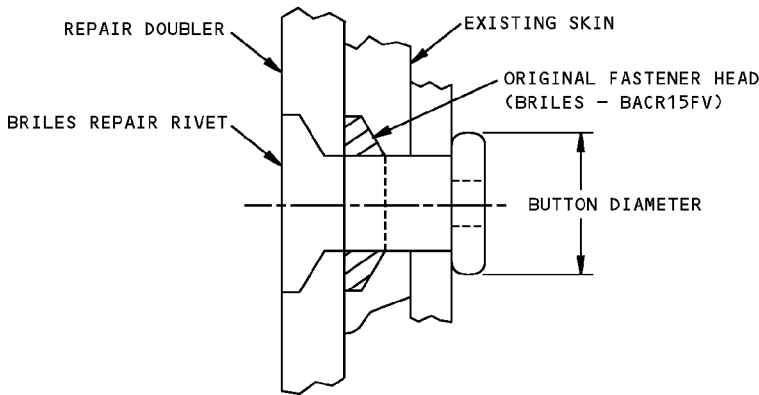
**757-200
STRUCTURAL REPAIR MANUAL**



TYPICAL SKIN REPAIR DOUBLER



SECTION A-A
(2X SIZE)



BRILES REPAIR RIVET SHOWN INSTALLED
SEE APPLICABLE REPAIR FOR REPAIR FASTENER
DETAIL I

**Method of Using Briles Rivet Head as Repair Washer for External Skin Repair
Figure 201 (Sheet 2 of 2)**

STRUCTURAL REPAIR MANUAL

REPAIR 2 - FUSELAGE SKIN - EXTERNAL REPAIR FOR DAMAGE AT A STRINGER WITH SOLID FASTENERS

APPLICABILITY N
<p>THIS CATEGORY B REPAIR IS APPLICABLE TO DAMAGE AT A STRINGER IN ZONES A AND B. CONTACT BOEING FOR REPAIRS IN ZONE C. D</p> <p>THIS REPAIR IS NOT APPLICABLE TO:</p> <ul style="list-style-type: none"> - DAMAGE THAT EXTENDS TO MORE THAN ONE STRINGER OR FRAME - DAMAGE AT OR ADJACENT TO A TEARSTRAP OR WHERE THE REQUIRED FASTENERS WOULD BE INSTALLED THROUGH A TEARSTRAP - DAMAGE AT A SKIN SPLICE WHERE THE REQUIRED REPAIR DOUBLER FASTENERS WOULD PICK UP THE EXISTING SPLICE FASTENERS - DAMAGE NEAR THE STATIC PORTS OR ANGLE OF ATTACK SENSORS B - DAMAGE ADJACENT TO ANOTHER REPAIR (INTERNAL OR EXTERNAL) WHERE EDGES OF EACH REPAIR ARE: <ul style="list-style-type: none"> - WITHIN 10 INCHES (25 CM) CIRCUMFERENTIALLY - WITHIN 20 INCHES (50 CM) LONGITUDINALLY - WITHIN 20 INCHES (50 CM) OF A DOOR CUTOUT - DAMAGE AT THE WINDOW BELT (FROM STRINGER S-10 TO S-14 LEFT/RIGHT).

7. Apply two coats of BMS 10-79, Type II or III primer to the repair parts and bare surfaces of the skin and stringer. Refer to SOPM 20-44-04.
8. Install the repair parts with BMS 5-95 sealant making faying surface seals between all parts in accordance with SRM 51-20-05. A bead of sealant should be apparent all around repair parts after installation. Where there is sufficient sealant squeezed out, it may be formed into a fillet, otherwise an additional fillet seal should be applied.
9. Install the fasteners given in Table III or Table IV.
10. Restore surface finish in accordance with AMM 51-21.

NOTES

- THIS REPAIR IS A CATEGORY B REPAIR IF THE REQUIRED REPAIR DOUBLER THICKNESS IN TABLE I IS NOT MORE THAN THE TABLE II LIMITS. THE CATEGORY B REPAIR HAS FAA APPROVAL IF YOU DO THE INSPECTIONS AT THE SPECIFIED THRESHOLD AND INTERVALS GIVEN IN TABLE V.
- ALL DIMENSIONS ARE IN INCHES.
- D = FASTENER DIAMETER
- WHEN YOU USE THIS REPAIR REFER TO:
 - AMM 51-21 FOR INTERIOR AND EXTERIOR FINISHES
 - SOPM 20-44-04 FOR APPLICATION OF URETHANE COMPATIBLE FINISHES
 - SRM 51-00-06 FOR REPAIR CATEGORIES AND DEFINITIONS
 - SRM 51-10-01 FOR AERODYNAMIC SMOOTHNESS REQUIREMENTS
 - SRM 51-10-02 FOR INSPECTION AND REMOVAL OF DAMAGE
 - SRM 51-20-01 FOR PROTECTIVE TREATMENT OF METAL
 - SRM 51-20-05 FOR SEALING OF FUSELAGE SKIN REPAIRS
 - SRM 51-30-01 FOR STANDARD ALUMINUM SHEET METAL GAGES
 - SRM 51-40 FOR FASTENER CODE, REMOVAL, INSTALLATION, HOLE SIZES, EDGE MARGINS AND SUBSTITUTION

REPAIR INSTRUCTIONS

1. Cut out damage to skin to a rectangular shape parallel to the stringer with a minimum corner radius of 0.50 inch (12.7 mm).
2. Drill out existing fasteners in the skin to stringer attachment as required.
3. Return all indented or projecting skin to contour. Remove all burrs, nicks, scratches, sharp edges or corners from the damaged area. Make the surface finish of 63 microinches Ra or better.
4. Do a High Frequency Eddy Current (HFEC) inspection along the edge of the cutout. Make sure there are no cracks. If there is no more damage, make the cutout larger by 0.04 inch (1 mm). All cutout edges must have a finish of 63 microinches Ra or better. Refer to 757 NDT part 6, 51-00-01.
5. Make the repair parts as given in Table I. Pre-form the repair doubler to the fuselage contour. Drill the appropriate fastener holes. Use a drill stop to restrict penetration through skin to 0.06 inch (1.5 mm) maximum. A F K
6. Apply a chemical conversion coating to the repair parts and bare surfaces of the skin and stringer.

**Fuselage Skin - External Repair for Damage at a Stringer with Solid Fasteners
Figure 201 (Sheet 1 of 6)**

STRUCTURAL REPAIR MANUAL

NOTES (CONTINUED)




- A** DO NOT END THE REPAIR DOUBLER ON A STRINGER OR OTHER STRUCTURE. ADD AN ADDITIONAL FASTENER ROW TO HAVE A BETTER INTERNAL INSPECTABILITY AND REPAIR DURABILITY.
- B** EXTERNAL REPAIRS CAN DISRUPT THE AIRFLOW AROUND STATIC PORTS AND ANGLE OF ATTACK SENSORS. THEREFORE EXTERNAL REPAIRS ARE NOT PERMITTED IN THESE AREAS. REFER TO SRM 51-10-01 FOR LOCATIONS OF THESE AREAS.
- C** 2P SPACING FOR OUTERMOST CIRCUMFERENTIAL ROWS FOR REPAIRS IN ZONE B. **D**
- D** REFER TO REPAIR GENERAL FOR DEFINITION OF REPAIR ZONES.
- E** LOW FREQUENCY EDDY CURRENT (LFEC) INSPECTION METHOD CAN BE USED ONLY IF THE REPAIR DOUBLER THICKNESS IS LESS THAN 0.11 INCH (2.8 mm).
- F** MAKE SURE THAT THE NECESSARY COUNTERSINK DEPTHS OF ALL FASTENERS ARE NOT MORE THAN 80 PERCENT OF THE THICKNESS OF THE DOUBLER BEFORE YOU COUNTERSINK THE FASTENER HOLES. USE THE EQUIVALENT PROTRUDING HEAD FASTENERS THAT FOLLOW IF COUNTERSINK DEPTH IS MORE THAN THE MAXIMUM DEPTH LIMIT.

INITIAL FASTENER	EQUIVALENT PROTRUDING HEAD FASTENER
BACR15FV()KE	BACR15FT()KE
BACR15CE()D	BACR15BB()D
BACB30NW()K	BACB30MY()K

- G** IF THE REQUIRED REPAIR DOUBLER THICKNESS IN TABLE I IS MORE THAN THE MAXIMUM THICKNESS PERMITTED IN TABLE II, THEN THE REPAIR IS A CATEGORY C REPAIR. REPLACE THE CATEGORY C REPAIR BEFORE 3,000 FLIGHT CYCLES. CONTACT BOEING FOR ALTERNATIVE CATEGORY B REPAIR.
- H** THE THRESHOLD IS BASED ON:
 - FLIGHT CYCLES FROM TIME OF REPAIR FOR ZONE A REPAIRS WITH NO INITIAL FASTENERS IN THE INSPECTION AREA EXCEPT THE TWO STRINGER FASTENERS (AT FORWARD AND AFT EDGE OF REPAIR)
 - TOTAL AIRFRAME FLIGHT CYCLES FOR ZONE A REPAIRS WITH INITIAL FASTENERS IN THE INSPECTION AREA IN ADDITION TO THE TWO STRINGER FASTENERS
 - TOTAL AIRFRAME FLIGHT CYCLES FOR ALL ZONE B REPAIRS.

- I** THIS THRESHOLD IS APPLICABLE TO:
 - ALL ZONE B REPAIRS
 - ZONE A REPAIRS WHERE THE THINNEST INITIAL SKIN THICKNESS IN THE INSPECTION AREA IS BETWEEN 0.040 AND 0.049 INCH (1.02 mm-1.24 mm).
- J** THIS THRESHOLD IS APPLICABLE TO ZONE A REPAIRS WHERE THE THINNEST INITIAL SKIN THICKNESS IN THE INSPECTION AREA IS EQUAL TO OR GREATER THAN 0.050 INCH (1.3 mm).
- K** IF THE FASTENER HOLES INTERSECT A CHEM-MILLED STEP, BLEND THE CHEM-MILLED STEP AS GIVEN IN SRM 53-00-01, IDENTIFICATION 1, DETAIL II. DO NOT MAKE THE BLEND DEEPER THAN THE DEPTH OF THE SKIN POCKET.
- L** WHEN A BLIND FASTENER IS REPLACED WITH A SOLID FASTENER, THE SOLID FASTENER MUST BE A MINIMUM OF 1/32 INCH LARGER THAN THE NOMINAL SIZE OF THE BLIND FASTENER THAT HAS BEEN REPLACED. **F**
- M** REFER TO SRM 51-30-01, FIGURE 2/GENERAL FOR THE MOST AVAILABLE STANDARD ALUMINUM SHEET METAL GAGES.
- N** FOR PASSENGER AIRPLANES ONLY.

FASTENER SYMBOLS

-  REFERENCE FASTENER LOCATIONS
-  REPAIR FASTENER LOCATIONS
-  INITIAL FASTENER LOCATIONS. INSTALL SAME TYPE AND SIZE AS PRODUCTION, 1/32 INCH OVERSIZE IF NECESSARY **F**

**Fuselage Skin - External Repair for Damage at a Stringer with Solid Fasteners
Figure 201 (Sheet 2 of 6)**

STRUCTURAL REPAIR MANUAL

REPAIR MATERIAL			
PART	QTY	MATERIAL	
1	DOUBLER	1	SAME MATERIAL AND ONE STANDARD GAGE THICKER THAN THE THICKEST TRIMMED SKIN THICKNESS. MINIMUM DOUBLER GAGE IS 0.050 INCH. [F][G][M]
2	FILLER	1	SAME MATERIAL AND THICKNESS AS INITIAL SKIN

MATERIAL REQUIREMENTS FOR REPAIRS IN ZONES A AND B [D]

TABLE I

REPAIR DOUBLER THICKNESS LIMITATION FOR CATEGORY B REPAIRS	
MINIMUM SKIN GAGE COMMON TO ANY REPAIR FASTENER	MAXIMUM REPAIR DOUBLER GAGE [G]
0.040	0.063
0.045	0.063
0.050	0.071
0.056	0.080
0.063	0.090
0.071	0.100
0.080	0.110
0.090	0.125

TABLE II

INITIAL MINIMUM SKIN POCKET THICKNESS IN REPAIR AREA	FASTENERS [L]	NUMBER OF ROWS		SPACING (P)
		LONGITUDINAL	CIRCUMFERENTIAL	
0.040	BACR15FV5KE	3	3	0.63 TO 0.91
0.045	BACR15FV5KE	3	3	0.63 TO 0.94
0.050	BACR15FV5KE	3	3	0.63 TO 0.94
0.056	BACR15FV6KE	3	3	0.75 TO 1.13
0.063	BACR15FV6KE	3	3	0.75 TO 1.13
0.071	BACR15FV6KE	3	3	0.75 TO 1.13
0.080	BACR15FV7KE	3	3	0.87 TO 1.30
0.090	BACR15FV8KE	3	3	1.00 TO 1.50

FASTENER REQUIREMENTS FOR REPAIRS IN ZONE A [D]

TABLE III

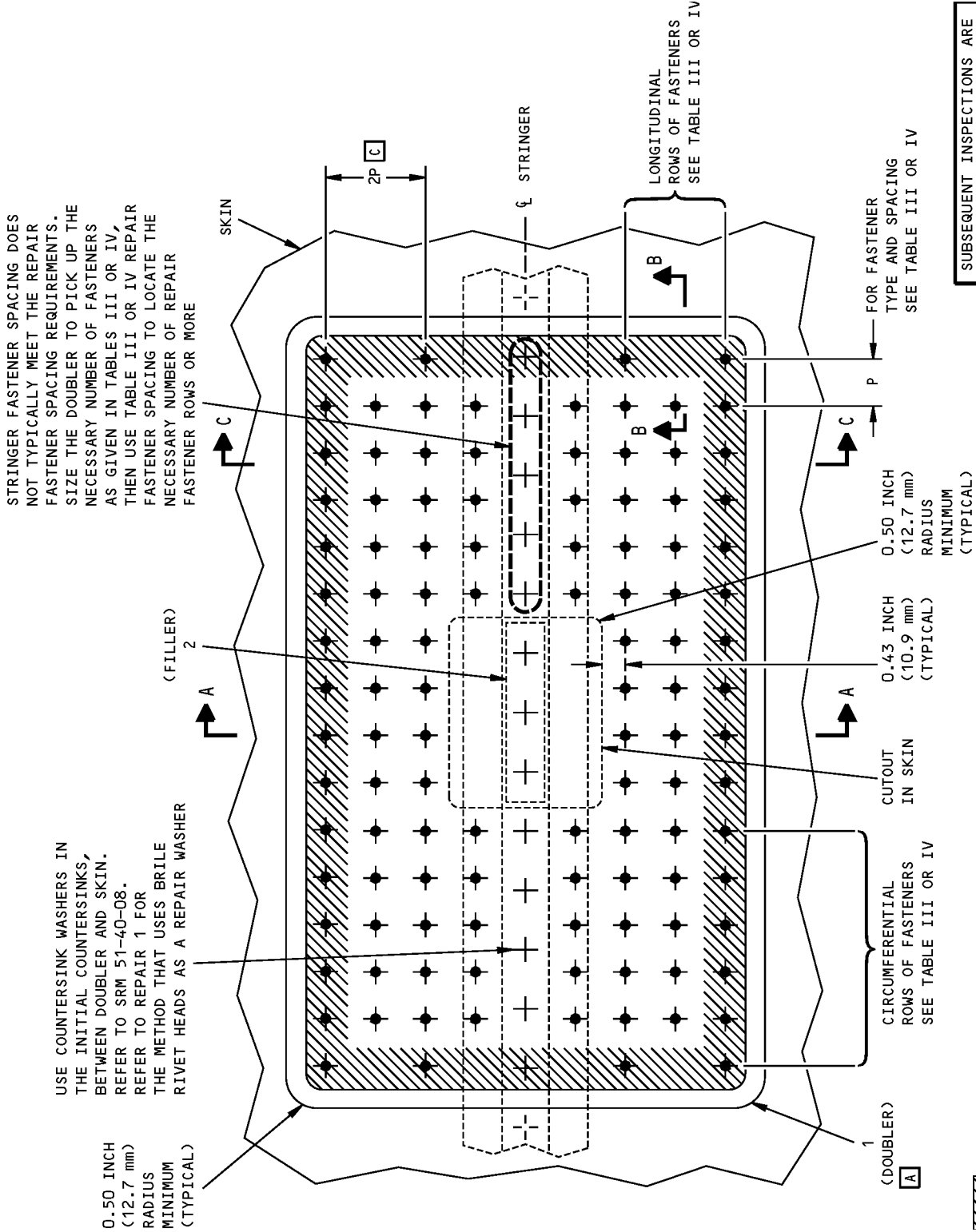
INITIAL MINIMUM SKIN POCKET THICKNESS IN REPAIR AREA	FASTENERS [L]	NUMBER OF ROWS		SPACING (P) [C]
		LONGITUDINAL	CIRCUMFERENTIAL	
0.040	BACR15FV5KE	3	5	0.63 TO 0.91
0.045	BACR15FV5KE	3	5	0.63 TO 0.94
0.050	BACR15FV5KE	3	5	0.63 TO 0.94
0.056	BACR15FV6KE	3	5	0.75 TO 1.13
0.063	BACR15FV6KE	3	5	0.75 TO 1.13
0.071	BACR15FV6KE	3	5	0.75 TO 1.13
0.080	BACR15FV7KE	3	5	0.87 TO 1.30
0.090	BACR15FV8KE	3	5	1.00 TO 1.50

FASTENER REQUIREMENTS FOR REPAIRS IN ZONE B [D]

TABLE IV

Fuselage Skin - External Repair for Damage at a Stringer with Solid Fasteners
Figure 201 (Sheet 3 of 6)

757-200
STRUCTURAL REPAIR MANUAL



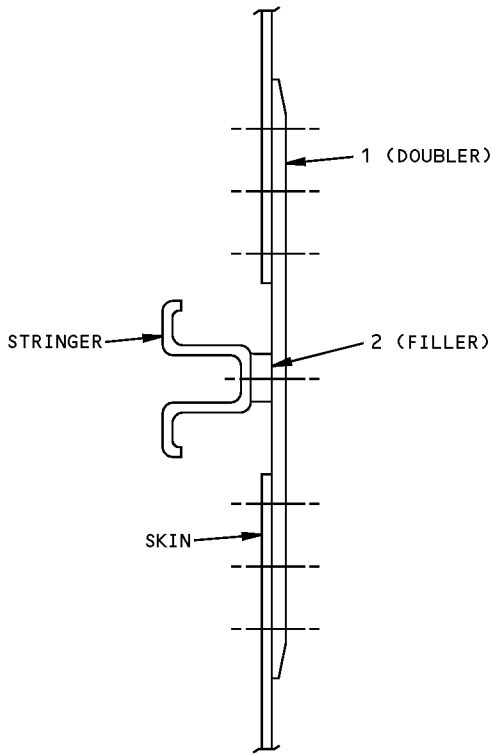
**Fuselage Skin - External Repair for Damage at a Stringer with Solid Fasteners
Figure 201 (Sheet 4 of 6)**

REPAIR 2
Page 204
Jan 20/2005

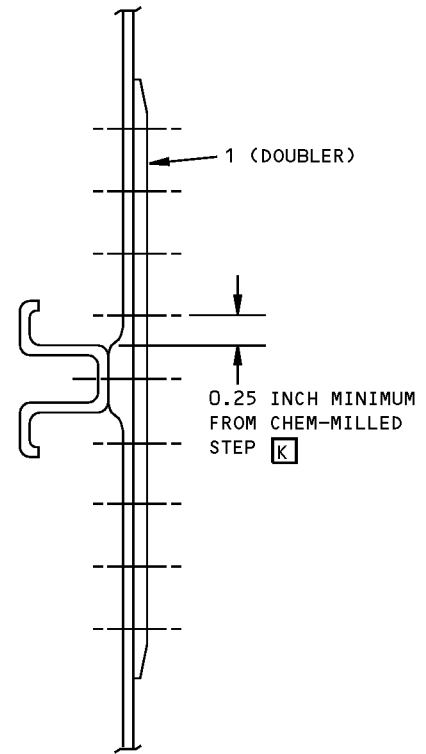
D634N201

53-00-01

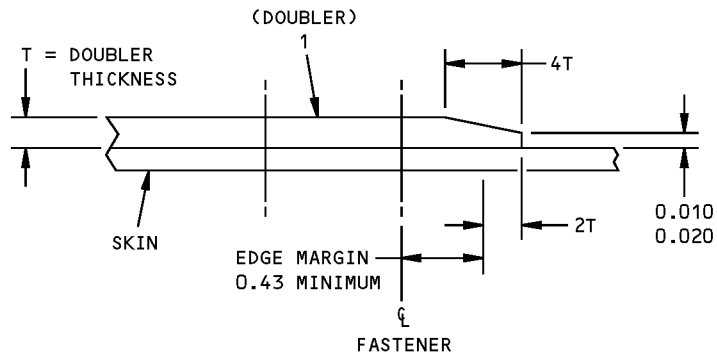
**757-200
STRUCTURAL REPAIR MANUAL**



SECTION A-A



SECTION C-C



SECTION B-B

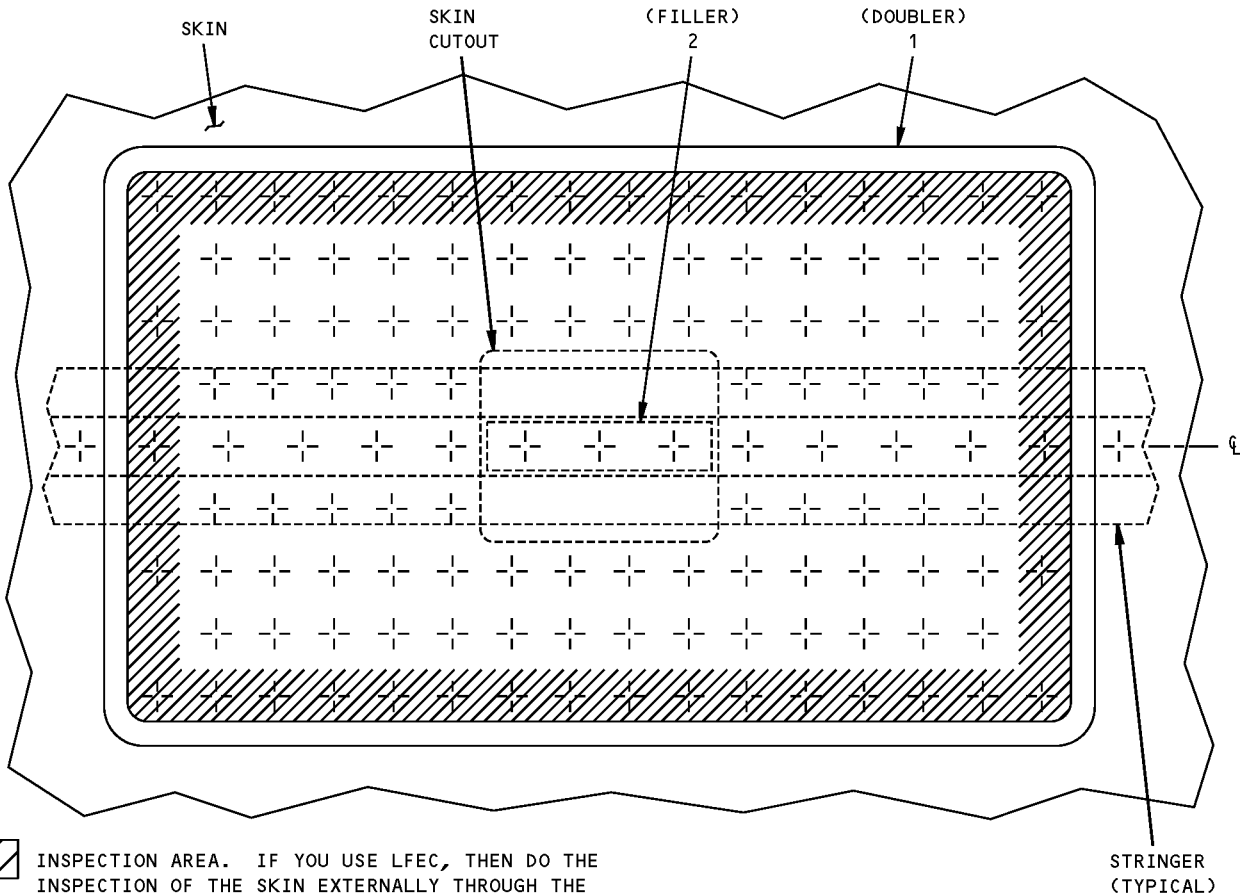
**Fuselage Skin - External Repair for Damage at a Stringer with Solid Fasteners
Figure 201 (Sheet 5 of 6)**


**757-200
STRUCTURAL REPAIR MANUAL**

CATEGORY B REPAIR INSPECTION REQUIREMENTS				
INSPECTION THRESHOLD H		REPEAT INSPECTION ALTERNATIVES		
		METHOD	INTERVAL	REFERENCE
25,000 FLIGHT CYCLES I	37,500 FLIGHT CYCLES J	HIGH FREQUENCY EDDY CURRENT (HFEC)	6,000 FLIGHT CYCLES	NDT PART 6 51-00-01
		LOW FREQUENCY EDDY CURRENT (LFEC) E	3,000 FLIGHT CYCLES	NDT PART 6 53-00-06

NOTE: INSPECT THE SKIN AROUND THE FIRST ROW OF FASTENERS ALONG THE EDGE OF THE DOUBLER AS SHOWN IN DETAIL II. USE ONE OF THE TWO INSPECTION METHODS.

TABLE V



 INSPECTION AREA. IF YOU USE LFEC, THEN DO THE INSPECTION OF THE SKIN EXTERNALLY THROUGH THE DOUBLER. IF YOU USE HFEC, INSPECT THE SKIN INTERNALLY. HOWEVER, HFEC INSPECTION IS NOT NECESSARY AROUND THE FASTENERS WHERE THE SKIN IS UNDER THE STRINGER.

DETAIL II

**Fuselage Skin - External Repair for Damage at a Stringer with Solid Fasteners
Figure 201 (Sheet 6 of 6)**

STRUCTURAL REPAIR MANUAL

REPAIR 3 - FUSELAGE SKIN - EXTERNAL REPAIR FOR DAMAGE BETWEEN STRINGERS WITH SOLID FASTENERS

APPLICABILITY Q
<p>THIS CATEGORY B REPAIR IS APPLICABLE TO DAMAGE BETWEEN STRINGERS IN ZONES A AND B. CONTACT BOEING FOR REPAIRS IN ZONE C. D</p> <p>THIS REPAIR IS NOT APPLICABLE TO:</p> <ul style="list-style-type: none"> - DAMAGE THAT EXTENDS TO MORE THAN ONE STRINGER OR FRAME - DAMAGE AT OR ADJACENT TO A TEARSTRAP OR WHERE THE REQUIRED FASTENERS WOULD BE INSTALLED THROUGH A TEARSTRAP - DAMAGE AT A SKIN SPLICE WHERE THE REQUIRED REPAIR DOUBLER FASTENERS WOULD PICK UP THE EXISTING SPLICE FASTENERS - DAMAGE NEAR THE STATIC PORTS OR ANGLE OF ATTACK SENSORS B - DAMAGE ADJACENT TO ANOTHER REPAIR (INTERNAL OR EXTERNAL) WHERE EDGES OF EACH REPAIR ARE: <ul style="list-style-type: none"> - WITHIN 10 INCHES (25 cm) CIRCUMFERENTIALLY - WITHIN 20 INCHES (50 cm) LONGITUDINALLY - WITHIN 20 INCHES (50 cm) OF A DOOR CUTOUT - DAMAGE AT THE WINDOW BELT (FROM STRINGER S-10 TO S-14 LEFT/RIGHT).

REPAIR INSTRUCTIONS

1. Cut out damage to skin to a rectangular shape parallel to the stringer with a minimum corner radius of 0.50 inch (12.7 mm).
2. Return all indented or projecting skin to contour. Remove all burrs, nicks, scratches, sharp edges or corners from the damaged area. Make the surface finish of 63 microinches Ra or better.
3. Do a High Frequency Eddy Current (HFEC) inspection along the edge of the cutout. Make sure there are no cracks. If there is no more damage, make the cutout larger by 0.04 inch (1 mm). All cutout edges must have a finish of 63 microinches Ra or better. Refer to 757 NDT part 6, 51-00-01.
4. Make the repair parts as given in Table I. Pre-form the repair doubler to the fuselage contour. Drill the appropriate fastener holes. Use a drill stop to restrict penetration through skin to 0.06 (1.5 mm) maximum. A F K

5. Apply a chemical conversion coating to the repair parts and bare surfaces of the skin.
6. Apply two coats of BMS 10-79, Type II or III primer to the repairs parts and bare surfaces of the skin. Refer to SOPM 20-44-04.
7. Install the repair parts with BMS 5-95 sealant making faying surface seals between all parts in accordance with SRM 51-20-05. A bead of sealant should be apparent all around repair parts after installation. Where there is sufficient sealant squeezed out, it may be formed into a fillet, otherwise an additional fillet seal should be applied.
8. Install the fasteners as given in Table III or Table IV.
9. Restore surface finish in accordance with AMM 51-21.

NOTES

- THIS REPAIR IS A CATEGORY B REPAIR IF THE REQUIRED DOUBLER THICKNESS IN TABLE I IS NOT MORE THAN THE TABLE II LIMITS. THE CATEGORY B REPAIR HAS FAA APPROVAL IF YOU DO THE INSPECTIONS AT THE SPECIFIED THRESHOLD AND INTERVALS AS GIVEN IN TABLE V.
- ALL DIMENSIONS ARE IN INCHES.
- D = FASTENER DIAMETER
- WHEN YOU USE THIS REPAIR, REFER TO:
 - AMM 51-21 FOR INTERIOR AND EXTERIOR FINISHES
 - SOPM 20-44-04 FOR APPLICATION OF URETHANE COMPATIBLE FINISHES
 - SRM 51-00-06 FOR REPAIR CATEGORIES AND DEFINITIONS
 - SRM 51-10-01 FOR AERODYNAMIC SMOOTHNESS REQUIREMENTS
 - SRM 51-10-02 FOR INSPECTION AND REMOVAL OF DAMAGE
 - SRM 51-20-01 FOR PROTECTIVE TREATMENT OF METAL
 - SRM 51-20-13 FOR SURFACE ROUGHNESS FINISH REQUIREMENTS
 - SRM 51-30-01 FOR STANDARD ALUMINUM SHEET METAL GAGES
 - SRM 51-20-05 FOR SEALING OF FUSELAGE SKIN REPAIRS
 - SRM 51-40 FOR FASTENER CODE, REMOVAL, INSTALLATION, HOLE SIZES, EDGE MARGINS AND SUBSTITUTION

**Fuselage Skin - External Repair for Damage Between Stringers with Solid Fasteners
Figure 201 (Sheet 1 of 6)**

STRUCTURAL REPAIR MANUAL

NOTES (CONTINUED)




- A** DO NOT END THE REPAIR DOUBLER ON A STRINGER OR OTHER STRUCTURE. IF THE LAST ROW OF FASTENERS COMES OVER A STRINGER, THEN ADD AN ADDITIONAL FASTENER ROW TO HAVE A BETTER INTERNAL INSPECTABILITY AND REPAIR DURABILITY.
- B** EXTERNAL REPAIRS CAN DISRUPT THE AIRFLOW AROUND STATIC PORTS AND ANGLE OF ATTACK SENSORS. THEREFORE, EXTERNAL REPAIRS ARE NOT PERMITTED IN THESE AREAS. REFER TO SRM 51-10-01 FOR LOCATIONS OF THESE AREAS.
- C** 2P SPACING FOR OUTERMOST CIRCUMFERENTIAL ROWS FOR REPAIRS IN ZONE B. **D**
- D** REFER TO REPAIR GENERAL FOR DEFINITION OF REPAIR ZONES.
- E** LOW FREQUENCY EDDY CURRENT (LFEC) INSPECTION METHOD CAN BE USED ONLY IF THE REPAIR DOUBLER THICKNESS IS LESS THAN 0.11 INCH (2.8 mm).
- F** MAKE SURE THAT THE NECESSARY COUNTERSINK DEPTHS OF ALL FASTENERS ARE NOT MORE THAN 80 PERCENT OF THE THICKNESS OF THE DOUBLER BEFORE YOU COUNTERSINK THE FASTENER HOLES. USE THE EQUIVALENT PROTRUDING HEAD FASTENERS THAT FOLLOW IF COUNTERSINK DEPTH IS MORE THAN THE MAXIMUM DEPTH LIMIT.

INITIAL FASTENER	EQUIVALENT PROTRUDING HEAD FASTENER
BACR15FV(<)KE	BACR15FT(<)KE
BACR15CE(<)D	BACR15BB(<)D
BACB30NW(<)K	BACB30MY(<)K

- G** IF THE REQUIRED REPAIR DOUBLER THICKNESS IN TABLE I IS MORE THAN THE MAXIMUM THICKNESS PERMITTED IN TABLE II, THEN THE REPAIR IS A CATEGORY C REPAIR. REPLACE THE CATEGORY C REPAIR BEFORE 3,000 FLIGHT CYCLES. CONTACT BOEING FOR ALTERNATIVE CATEGORY B REPAIR.
- H** THE THRESHOLD IS BASED ON:
 - FLIGHT CYCLES FROM THE TIME OF THE REPAIR FOR ZONE A REPAIRS WITH NO INITIAL FASTENERS IN THE INSPECTION AREA EXCEPT THE TWO STRINGER FASTENERS (AT THE FORWARD AND AFT EDGES OF THE REPAIR)
 - TOTAL AIRFRAME FLIGHT CYCLES FOR ZONE A REPAIRS WITH INITIAL FASTENERS IN THE INSPECTION AREA IN ADDITION TO THE TWO STRINGER FASTENERS
 - TOTAL AIRFRAME FLIGHT CYCLES FOR ALL ZONE B REPAIRS.

- I** THIS THRESHOLD IS APPLICABLE TO:
 - ALL ZONE B REPAIRS
 - ZONE A REPAIRS WHERE THE THINNEST INITIAL SKIN THICKNESS IN THE INSPECTION AREA IS BETWEEN 0.040 AND 0.049 INCH (1.02 mm TO 1.04 mm).
- J** THIS THRESHOLD IS APPLICABLE TO ZONE A REPAIRS WHERE THE THINNEST INITIAL SKIN THICKNESS IN THE INSPECTION AREA IS EQUAL TO OR GREATER THAN 0.050 INCH (1.3 mm).
- K** IF THE FASTENER HOLES INTERSECT A CHEM-MILLED STEP, BLEND THE CHEM-MILLED STEP AS GIVEN IN SRM 53-00-01, IDENTIFICATION 1, DETAIL II. DO NOT MAKE THE BLEND DEEPER THAN THE DEPTH OF THE SKIN POCKET.
- L** INSTALL FASTENERS AT ALL REPAIR DOUBLER CORNERS.
- M** WHEN A BLIND FASTENER IS REPLACED WITH A SOLID FASTENER, THE SOLID FASTENER MUST BE A MINIMUM OF 1/32 INCH LARGER THAN THE NOMINAL SIZE OF THE BLIND FASTENER THAT HAS BEEN REPLACED. **F**
- N** REFER TO SRM 51-30-01, FIGURE 2/GENERAL FOR THE MOST AVAILABLE STANDARD ALUMINUM SHEET METAL GAGES.
- O** FOR PASSENGER AIRPLANES ONLY.

FASTENER SYMBOLS

-  REFERENCE FASTENER LOCATIONS
-  REPAIR FASTENER LOCATIONS
-  INITIAL FASTENER LOCATIONS. INSTALL SAME TYPE AND SIZE AS PRODUCTION, 1/32 INCH OVERSIZE IF NECESSARY. **F**

**Fuselage Skin - External Repair for Damage Between Stringers with Solid Fasteners
Figure 201 (Sheet 2 of 6)**

STRUCTURAL REPAIR MANUAL

REPAIR MATERIAL			
PART		QTY	MATERIAL
1	DOUBLER	1	SAME MATERIAL AND ONE STANDARD GAGE THICKER THAN THE THICKEST TRIMMED SKIN THICKNESS. MINIMUM DOUBLER GAGE IS 0.050 INCH. [F] [G] [N]

MATERIAL REQUIREMENTS FOR REPAIRS IN ZONES A AND B [D]
TABLE I

REPAIR DOUBLER THICKNESS LIMITATION FOR CATEGORY B REPAIRS	
MINIMUM SKIN GAGE COMMON TO ANY REPAIR FASTENER	MAXIMUM REPAIR DOUBLER GAGE [G]
0.040	0.063
0.045	0.063
0.050	0.071
0.056	0.080
0.063	0.090
0.071	0.100
0.080	0.110
0.090	0.125

TABLE II

INITIAL MINIMUM SKIN POCKET THICKNESS IN REPAIR AREA	FASTENERS [M]	NUMBER OF ROWS		SPACING (P)
		LONGITUDINAL	CIRCUMFERENTIAL	
0.040	BACR15FV5KE	3	3	0.63 TO 0.91
0.045	BACR15FV5KE	3	3	0.63 TO 0.94
0.050	BACR15FV5KE	3	3	0.63 TO 0.94
0.056	BACR15FV6KE	3	3	0.75 TO 1.13
0.063	BACR15FV6KE	3	3	0.75 TO 1.13
0.071	BACR15FV6KE	3	3	0.75 TO 1.13
0.080	BACR15FV7KE	3	3	0.87 TO 1.30
0.090	BACR15FV8KE	3	3	1.00 TO 1.50

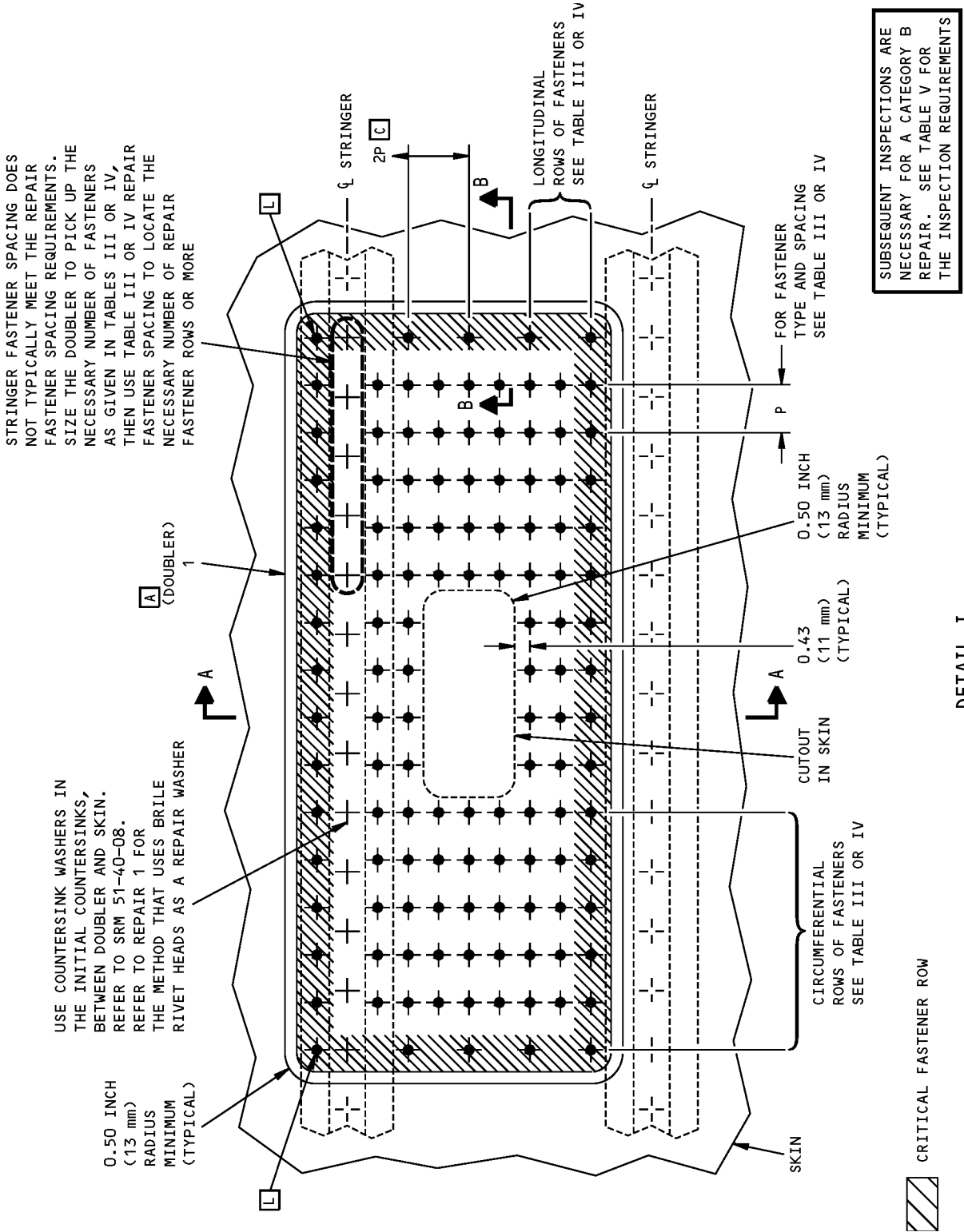
FASTENER REQUIREMENTS FOR REPAIRS IN ZONE A [D]
TABLE III

INITIAL MINIMUM SKIN POCKET THICKNESS IN REPAIR AREA	FASTENERS [M]	NUMBER OF ROWS		SPACING [C] (P)
		LONGITUDINAL	CIRCUMFERENTIAL	
0.040	BACR15FV5KE	3	5	0.63 TO 0.91
0.045	BACR15FV5KE	3	5	0.63 TO 0.94
0.050	BACR15FV5KE	3	5	0.63 TO 0.94
0.056	BACR15FV6KE	3	5	0.75 TO 1.13
0.063	BACR15FV6KE	3	5	0.75 TO 1.13
0.071	BACR15FV6KE	3	5	0.75 TO 1.13
0.080	BACR15FV7KE	3	5	0.87 TO 1.30
0.090	BACR15FV8KE	3	5	1.00 TO 1.50

FASTENER REQUIREMENTS FOR REPAIRS IN ZONE B [D]
TABLE IV

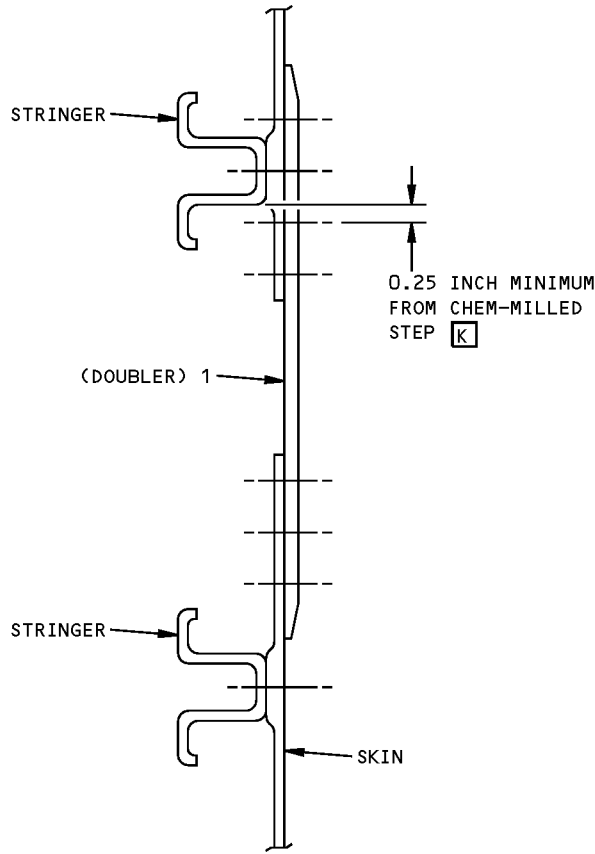
Fuselage Skin - External Repair for Damage Between Stringers with Solid Fasteners
Figure 201 (Sheet 3 of 6)

STRUCTURAL REPAIR MANUAL

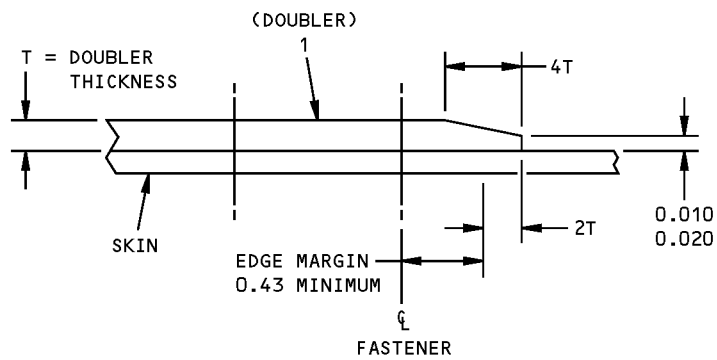


Fuselage Skin - External Repair for Damage Between Stringers with Solid Fasteners
Figure 201 (Sheet 4 of 6)

**757-200
STRUCTURAL REPAIR MANUAL**



SECTION A-A



SECTION B-B

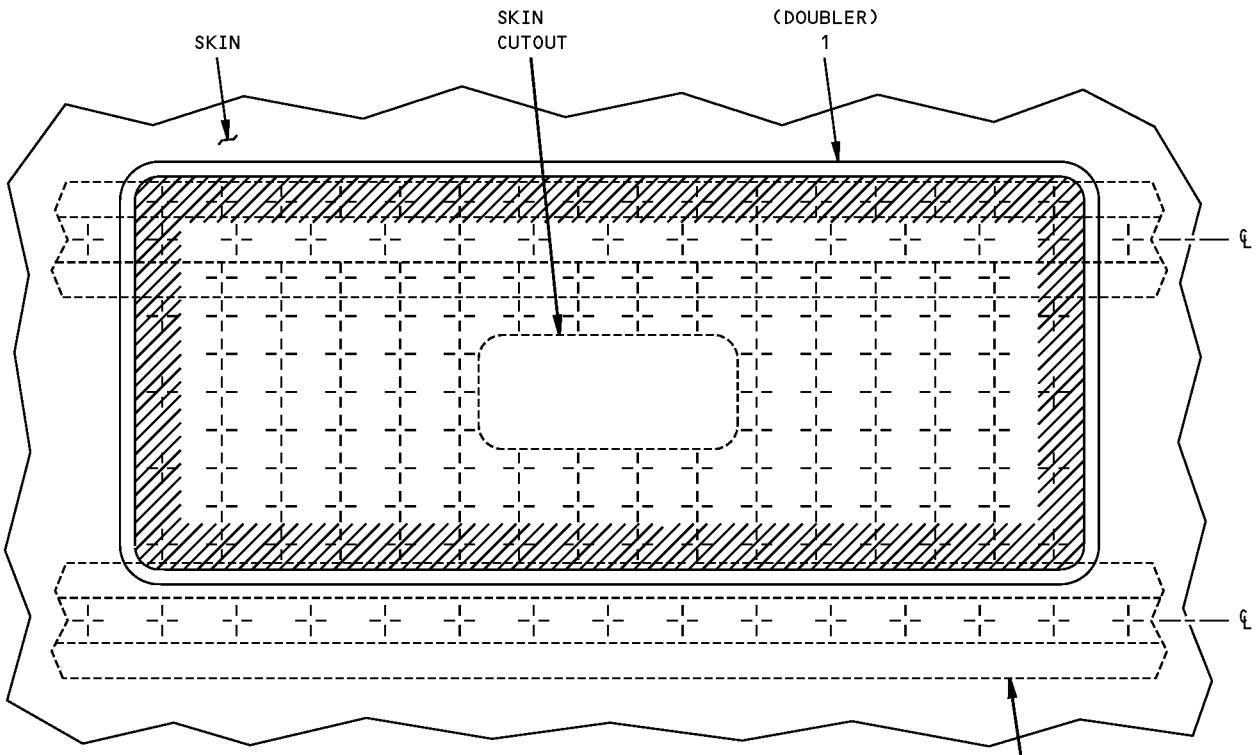
**Fuselage Skin - External Repair for Damage Between Stringers with Solid Fasteners
Figure 201 (Sheet 5 of 6)**


STRUCTURAL REPAIR MANUAL

CATEGORY B REPAIR INSPECTION REQUIREMENTS				
INSPECTION THRESHOLD ^H		REPEAT INSPECTION ALTERNATIVES		
		METHOD	INTERVAL	REFERENCE
25,000 FLIGHT CYCLES ^I	37,500 FLIGHT CYCLES ^J	HIGH FREQUENCY EDDY CURRENT (HFEC)	6,000 FLIGHT CYCLES	NDT PART 6 51-00-01
		LOW FREQUENCY EDDY CURRENT (LFEC) ^E	3,000 FLIGHT CYCLES	NDT PART 6 53-00-06

NOTE: INSPECT THE SKIN AROUND THE FIRST ROW OF FASTENERS ALONG THE EDGE OF THE DOUBLER AS SHOWN IN DETAIL II. USE ONE OF THE TWO INSPECTION METHODS.

TABLE V



 INSPECTION AREA. IF YOU USE LFEC, THEN DO THE INSPECTION OF THE SKIN EXTERNALLY THROUGH THE DOUBLER. IF YOU USE HFEC, INSPECT THE SKIN INTERNALLY. HOWEVER, HFEC INSPECTION IS NOT NECESSARY AROUND THE FASTENERS WHERE THE SKIN IS UNDER THE STRINGER.

DETAIL II

Fuselage Skin - External Repair for Damage Between Stringers with Solid Fasteners
Figure 201 (Sheet 6 of 6)

STRUCTURAL REPAIR MANUAL

REPAIR 4 - FUSELAGE SKIN - FLUSH REPAIR AT A STRINGER

APPLICABILITY
THIS REPAIR DOES NOT APPLY TO DAMAGE AT SKIN SPLICES, THE WINDOW BELT, AND SKIN CUTOUTS. [G]

REPAIR INSTRUCTIONS

1. Drill out fasteners as required to remove initial external repair parts.
 2. Drill out as many skin to stringer fasteners as are required to install the new repair plate between the stringer and skin.
 3. Fabricate repair parts and drill appropriate fastener holes. Pick up all initial repair fastener holes. **[D]**
- NOTE:** For repairs in zones A and B, prepare and install repair parts per step 4. For repairs in zone C, prepare and install repair parts per step 5. **[F]**
4. For repairs in zones A and B, prepare and install repair parts per the following:
 - (a) Apply chemical conversion coating to the repair parts and to the bare surfaces of the cut edges.
 - (b) For repairs in upper lobe, apply one layer of BMS 10-11 Type 1 primer. For repairs in lower lobe, apply one layer of BMS 10-11 Type 1 primer and one coat of BMS 10-11 Type 2 enamel to faying surfaces in accordance with AMM 51-21-00.
 - (c) Install the repair parts with BMS 5-95 sealant making faying surface seals between all parts in accordance with AMM 51-20-05. A bead of sealant should be apparent all around repair parts after installation. Where there is sufficient sealant squeezed out, it may be formed into a fillet; otherwise, an additional fillet should be applied. Install the rivets without sealant. BACR15FV rivets should never be installed with sealant.

NOTE: Ensure that drain paths provided at manufacture are not covered by sealant. It is recommended that other drain paths be checked and cleared of accumulated debris.
 5. For repairs in zone C, prepare and install repair parts per the following:
 - (a) Drill 0.125 (3 mm) vent holes at fastener locations.
 - (b) Clean and prepare the repair parts with PANTA or HF/alodine as given in SRM 51-70-09.

NOTE: PANTA is the preferred method.

- (c) Install repair parts with BMS 5-101 structural adhesive and cure as given in SRM 51-70-09.

NOTE: Do not install fasteners until cure cycle is complete.

- (d) Install the rivets without sealant. BACR15FV rivets should never be installed with sealant. Fillet seal the repair with BMS 5-95 sealant as given in SRM 51-20-05.

6. Restore surface finish in accordance with AMM 51-21.

NOTES

- THIS IS A CATEGORY A REPAIR FOR 757-SF AIRPLANES. THE INSPECTIONS GIVEN IN THE MAINTENANCE PLANNING DATA (MPD) ARE SUFFICIENT TO MAINTAIN THE DAMAGE TOLERANCE OF THE INITIAL STRUCTURE WITH THIS REPAIR INSTALLED. REFER TO SRM 51-00-06 FOR REPAIR CATEGORIES AND DEFINITIONS.
- REFER TO THE FOLLOWING WHEN USING THIS REPAIR:
 - AMM 51-21 FOR INTERIOR AND EXTERIOR FINISHES
 - SRM 51-10-01 FOR AERODYNAMIC SMOOTHNESS REQUIREMENTS
 - SRM 51-10-02 FOR INSPECTION AND REMOVAL OF DAMAGE
 - SRM 51-20-01 FOR PROTECTIVE TREATMENT OF METAL
 - SRM 51-20-05 FOR SEALING OF FUSELAGE SKIN REPAIRS
 - SRM 51-40 FOR FASTENER CODE, REMOVAL, INSTALLATION, HOLE SIZES AND EDGE MARGINS
 - SRM 51-40-08 FOR COUNTERSUNK WASHERS.

[A] TO AVOID KNIFE-EDGING OF THE SKIN, DO NOT COUNTERSINK DEEPER THAN 70% OF SKIN THICKNESS. **[E]**

[B] USE 2P FASTENER SPACING FOR OUTER-MOST CIRCUMFERENTIAL ROWS.

[C] WHEN REPLACING EXTERNAL REPAIR, USE SAME SPACING AND ONE EXTRA ROW OF FASTENERS IN EACH SHIM.

[D] FOR ZONE C REPAIRS, DO NOT DRILL FASTENER HOLES OTHER THAN 0.125 (3 mm) PILOT HOLES AT FASTENER LOCATIONS WHERE VENT HOLES ARE NEEDED.

**Fuselage Skin - Flush Repair at a Stringer
Figure 201 (Sheet 1 of 4)**

STRUCTURAL REPAIR MANUAL

- E** BACR15FT*KE PROTRUDING HEAD RIVETS MAY BE SUBSTITUTED FOR BACR15FV*KE RIVETS. USE SAME SIZE, SPACING, AND NUMBER OF ROWS AS REQUIRED FOR BACR15FV*KE RIVETS. FOR REPAIRS INSIDE THE REGION AROUND STATIC PORTS AND ANGLE OF ATTACK SENSORS, USE ONLY BACR15FV*KE RIVETS. REFER TO SRM 51-10-01 FOR LOCATIONS OF THESE AREAS.
- F** REFER TO REPAIR GENERAL FOR 757 PASSENGER AND 757-SF DEFINITION OF REPAIR ZONES.
- G** FOR 757-SF AIRPLANES:
 - THIS REPAIR IS NOT APPLICABLE TO REPAIR PLATES GREATER THAN 17 INCHES IN LENGTH.
 - THIS FLUSH REPAIR IS NOT PERMITTED BETWEEN STA 760 AND STA 880, S-5R TO S-5L.

REPAIR MATERIAL			
PART		QTY	MATERIAL
1	REPAIR PLATE	1	SAME MATERIAL AND ONE GAGE HEAVIER THAN THE THICKEST MACHINED SKIN POCKET IN THE REPAIR AREA
2	FILLER	1	SAME MATERIAL AND THICKNESS AS INITIAL SKIN PAD
3	SHIM	2	SAME MATERIAL AS INITIAL SKIN. THICKNESS IS TO BE THE DIFFERENCE BETWEEN THE SKIN PAD GAGE AND THE SKIN POCKET GAGE
4	TAPERED SHIM	2	SAME MATERIAL AS INITIAL SKIN. SEE DETAIL I FOR DIMENSIONS

FASTENER SYMBOLS

✦ REPAIR FASTENER LOCATION

✚ INITIAL FASTENER LOCATION

INITIAL MINIMUM SKIN POCKET GAGE IN REPAIR AREA	FASTENERS A E	NUMBER OF ROWS C		SPACING (P)
		LONGITUDINAL	CIRCUMFERENTIAL	
0.040	BACR15FT5KE	4	4	0.63 TO 0.77
0.045	BACR15FT5KE	4	4	0.63 TO 0.77
0.050	BACR15FV5KE	4	4	0.63 TO 0.74
0.056	BACR15FV6KE	4	4	0.75 TO 0.96
0.063	BACR15FV6KE	4	4	0.75 TO 0.92
0.071	BACR15FV6KE	4	4	0.75 TO 0.86
0.080	BACR15FV7KE	4	4	0.87 TO 1.06
0.090	BACR15FV8KE	4	4	1.00 TO 1.10

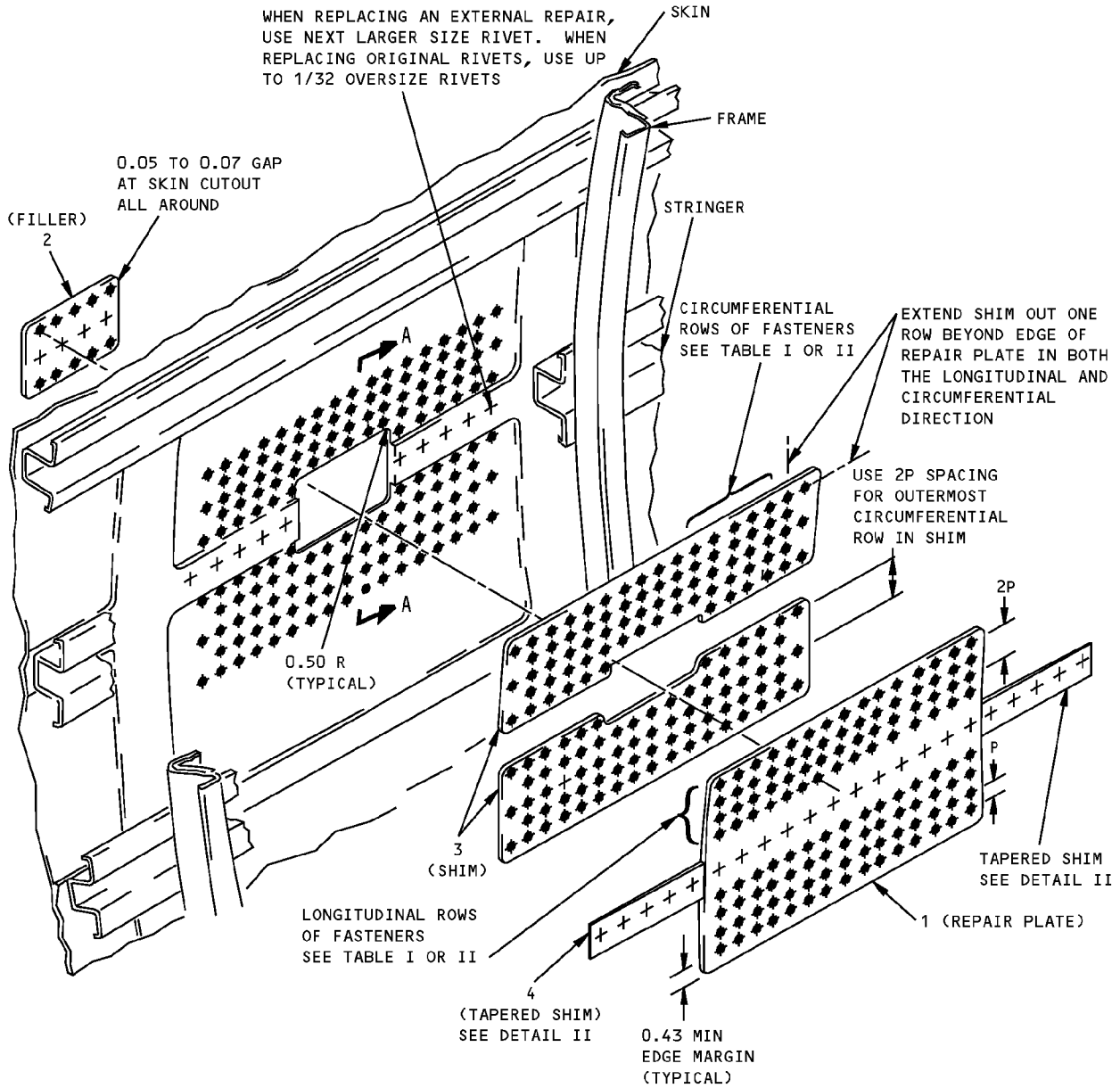
FASTENER REQUIREMENTS FOR REPAIRS IN ZONE A
TABLE I

INITIAL MINIMUM SKIN POCKET GAGE IN REPAIR AREA	FASTENERS A E	NUMBER OF ROWS C		SPACING B (P)
		LONGITUDINAL	CIRCUMFERENTIAL	
0.040	BACR15FT5KE	4	6	0.63 TO 0.77
0.045	BACR15FT5KE	4	6	0.63 TO 0.77
0.050	BACR15FV5KE	4	6	0.63 TO 0.72
0.056	BACR15FV6KE	4	6	0.75 TO 0.94
0.063	BACR15FV6KE	4	6	0.75 TO 0.90
0.071	BACR15FV6KE	4	6	0.75 TO 0.84
0.080	BACR15FV7KE	4	6	0.87 TO 1.03
0.090	BACR15FV8KE	4	6	1.00 TO 1.10

FASTENER REQUIREMENTS FOR REPAIRS IN ZONES B AND C
TABLE II

Fuselage Skin - Flush Repair at a Stringer
Figure 201 (Sheet 2 of 4)

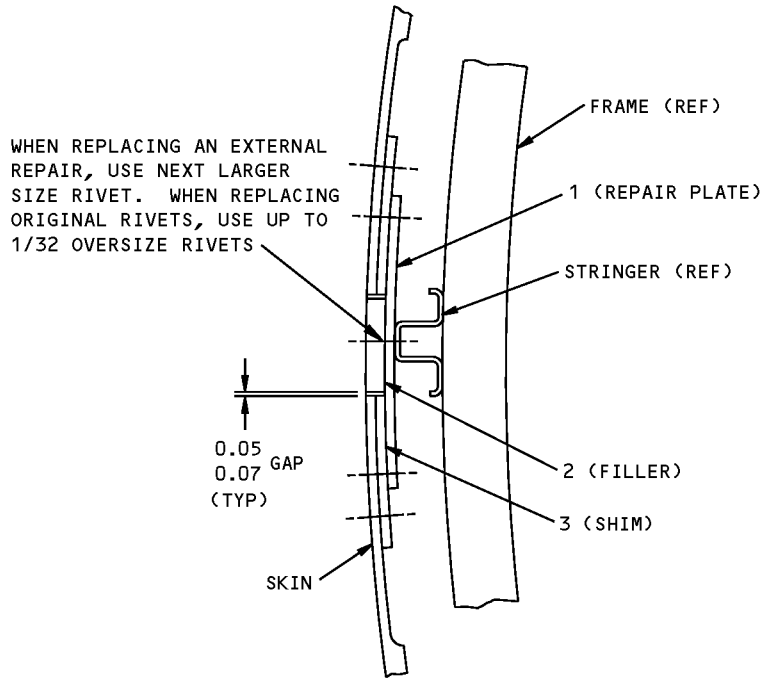
**757-200
STRUCTURAL REPAIR MANUAL**



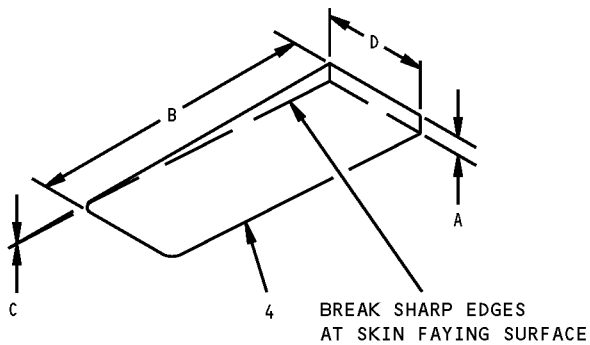
DETAIL I

**Fuselage Skin - Flush Repair at a Stringer
Figure 201 (Sheet 3 of 4)**

**757-200
STRUCTURAL REPAIR MANUAL**



SECTION A-A



DETAIL II

DIMENSIONS FOR PART NO. 4				
ORIGINAL SKIN GAGE	DIM. A	DIM. B	DIM. C	DIM. D
0.040	0.045	6.0	0.02 0.01	1.3
0.045	0.050	6.0	0.02 0.01	1.3
0.050	0.056	6.0	0.02 0.01	1.3
0.056	0.063	6.0	0.02 0.01	1.3
0.063	0.071	6.0	0.02 0.01	1.3
0.071	0.080	6.0	0.02 0.01	1.3
0.080	0.090	6.0	0.02 0.01	1.3
0.090	0.100	6.0	0.02 0.01	1.3

**Fuselage Skin - Flush Repair at a Stringer
Figure 201 (Sheet 4 of 4)**

STRUCTURAL REPAIR MANUAL

REPAIR 5 - FUSELAGE SKIN - FLUSH REPAIR BETWEEN STRINGERS

APPLICABILITY
THIS REPAIR DOES NOT APPLY TO DAMAGE EXTENDING TO MORE THAN ONE STRINGER OR FRAME, DAMAGE AT SKIN SPLICES, THE WINDOW BELT, AND SKIN CUTOUTS. G

REPAIR INSTRUCTIONS

1. Drill out fasteners as required to remove initial external repair parts.
2. Fabricate repair parts and drill appropriate fastener holes. Pick up all initial repair fastener holes. **D**

NOTE: For repairs in zones A and B, prepare and install repair parts per step 3. For repairs in zone C, prepare and install repair parts per step 4. **F**

3. For repairs in zones A and B, prepare and install repair parts per the following:
 - (a) Apply chemical conversion coating to the repair parts and to the bare surfaces of the cut edges.
 - (b) For repairs in upper lobe, apply one layer of BMS 10-11 Type 1 primer. For repairs in lower lobe, apply one layer of BMS 10-11 Type 1 primer and one coat of BMS 10-11 Type 2 enamel to faying surfaces in accordance with AMM 51-21-00.
 - (c) Install the repair parts with BMS 5-95 sealant making faying surface seals between all parts in accordance with SRM 51-20-05. A bead of sealant should be apparent all around repair parts after installation. Where there is sufficient sealant squeezed out, it may be formed into a fillet; otherwise, an additional fillet should be applied. Install the rivets without sealant. BACR15FV rivets should never be installed with sealant.

NOTE: Ensure that drain paths provided at manufacture are not covered by sealant. It is recommended that other drain paths be checked and cleared of accumulated debris.
4. For repairs in zone C, prepare and install repair parts per the following:
 - (a) Drill 0.125 (3.2 mm) vent holes at fastener locations.
 - (b) Clean and prepare the repair parts with PANTA or HF/alodine per SRM 51-70-09.

NOTE: PANTA is the preferred method.

- (c) Install repair parts with BMS 5-101 structural adhesive and cure as given in SRM 51-70-09.
- (d) Install the rivets without sealant. BACR15FV rivets should never be installed with sealant. Fillet seal the repair with BMS 5-95 sealant as given in SRM 51-20-05.

5. Restore surface finish in accordance with AMM 51-21.

NOTES

- THIS IS A CATEGORY A REPAIR FOR 757-SF AIRPLANES. THE INSPECTIONS GIVEN IN THE MAINTENANCE PLANNING DATA (MPD) ARE SUFFICIENT TO MAINTAIN THE DAMAGE TOLERANCE OF THE INITIAL STRUCTURE WITH THIS REPAIR INSTALLED. REFER TO SRM 51-00-06 FOR REPAIR CATEGORIES AND DEFINITIONS.
- REFER TO THE FOLLOWING WHEN USING THIS REPAIR:
 - AMM 51-21 FOR INTERIOR AND EXTERIOR FINISHES
 - SRM 51-10-01 FOR AERODYNAMIC SMOOTHNESS REQUIREMENTS
 - SRM 51-10-02 FOR INSPECTION AND REMOVAL OF DAMAGE
 - SRM 51-20-01 FOR PROTECTIVE TREATMENT OF METAL
 - SRM 51-20-05 FOR SEALING OF FUSELAGE SKIN REPAIRS
 - SRM 51-40 FOR FASTENER CODE, REMOVAL, INSTALLATION, HOLE SIZES AND EDGE MARGINS
 - SRM 51-40-08 FOR COUNTERSUNK WASHERS.

A TO AVOID KNIFE-EDGING OF THE SKIN, DO NOT COUNTERSINK DEEPER THAN 70% OF SKIN THICKNESS. **E**

B USE 2P FASTENER SPACING FOR OUTER-MOST CIRCUMFERENTIAL ROWS.

C WHEN REPLACING EXTERNAL REPAIR, USE SAME NUMBER OF ROWS AND SAME FASTENER SPACING AS REPAIR BEING REPLACED.

D FOR ZONE C REPAIRS, DO NOT DRILL FASTENER HOLES OTHER THAN 0.125 (3.2 mm) PILOT HOLES AT FASTENER LOCATIONS WHERE VENT HOLES ARE NEEDED.

E BACR15FT*KE PROTRUDING HEAD RIVETS MAY BE SUBSTITUTED FOR BACR15FV*KE RIVETS. USE SAME SIZE, SPACING, AND NUMBER OF ROWS AS REQUIRED FOR BACR15FV*KE RIVETS. FOR REPAIRS INSIDE THE REGION AROUND STATIC PORTS AND ANGLE OF ATTACK SENSORS, USE ONLY BACR15FV*KE RIVETS. REFER TO SRM 51-10-01 FOR LOCATIONS OF THESE AREAS.

**Fuselage Skin - Flush Repair Between Stringers
Figure 201 (Sheet 1 of 4)**

**757-200
STRUCTURAL REPAIR MANUAL**

- F** REFER TO REPAIR GENERAL FOR 757 PASSENGER AND 757-SF DEFINITION OF REPAIR ZONES.
- G** FOR 757-SF AIRPLANES:
- THIS REPAIR IS NOT APPLICABLE TO REPAIR PLATES GREATER THAN 17 INCHES (432 mm) IN LENGTH.
 - THIS FLUSH REPAIR IS NOT PERMITTED BETWEEN STA 760 AND STA 880, S-5R TO S-5L.

REPAIR MATERIAL			
PART		QTY	MATERIAL
1	REPAIR PLATE	1	SAME MATERIAL AND ONE GAGE HEAVIER THAN THE SKIN POCKET IN THE REPAIR AREA
2	FILLER	1	SAME MATERIAL AND THICKNESS AS INITIAL SKIN POCKET GAGE IN THE REPAIR AREA

FASTENER SYMBOLS

- ✦ REPAIR FASTENER LOCATION
- ✚ INITIAL FASTENER LOCATION

INITIAL MINIMUM SKIN POCKET GAGE IN REPAIR AREA	FASTENERS A E	NUMBER OF ROWS C		SPACING (P)
		LONGITUDINAL	CIRCUMFERENTIAL	
0.040	BACR15FT5KE	3	3	0.63 TO 0.77
0.045	BACR15FT5KE	3	3	0.63 TO 0.77
0.050	BACR15FV5KE	3	3	0.63 TO 0.74
0.056	BACR15FV6KE	3	3	0.75 TO 0.96
0.063	BACR15FV6KE	3	3	0.75 TO 0.92
0.071	BACR15FV6KE	3	3	0.75 TO 0.86
0.080	BACR15FV7KE	3	3	0.87 TO 1.06
0.090	BACR15FV8KE	3	3	1.00 TO 1.10

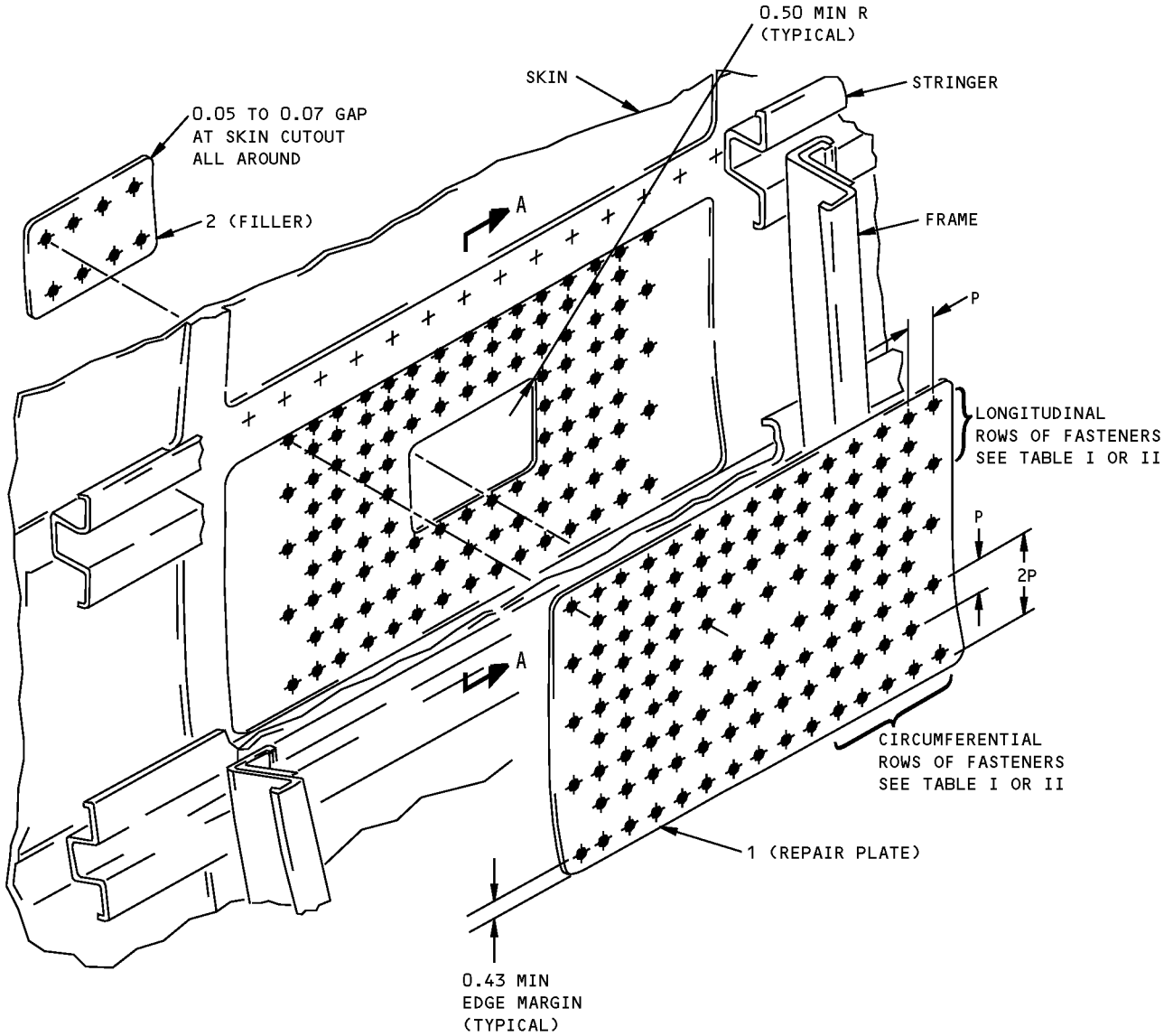
**FASTENER REQUIREMENTS FOR REPAIRS IN ZONE A
TABLE I**

INITIAL MINIMUM SKIN POCKET GAGE IN REPAIR AREA	FASTENERS A E	NUMBER OF ROWS C		SPACING B (P)
		LONGITUDINAL	CIRCUMFERENTIAL	
0.040	BACR15FT5KE	3	5	0.63 TO 0.77
0.045	BACR15FT5KE	3	5	0.63 TO 0.77
0.050	BACR15FV5KE	3	5	0.63 TO 0.72
0.056	BACR15FV6KE	3	5	0.75 TO 0.94
0.063	BACR15FV6KE	3	5	0.75 TO 0.90
0.071	BACR15FV6KE	3	5	0.75 TO 0.84
0.080	BACR15FV7KE	3	5	0.87 TO 1.03
0.090	BACR15FV8KE	3	5	1.00 TO 1.10

**FASTENER REQUIREMENTS FOR REPAIRS IN ZONES B AND C
TABLE II**

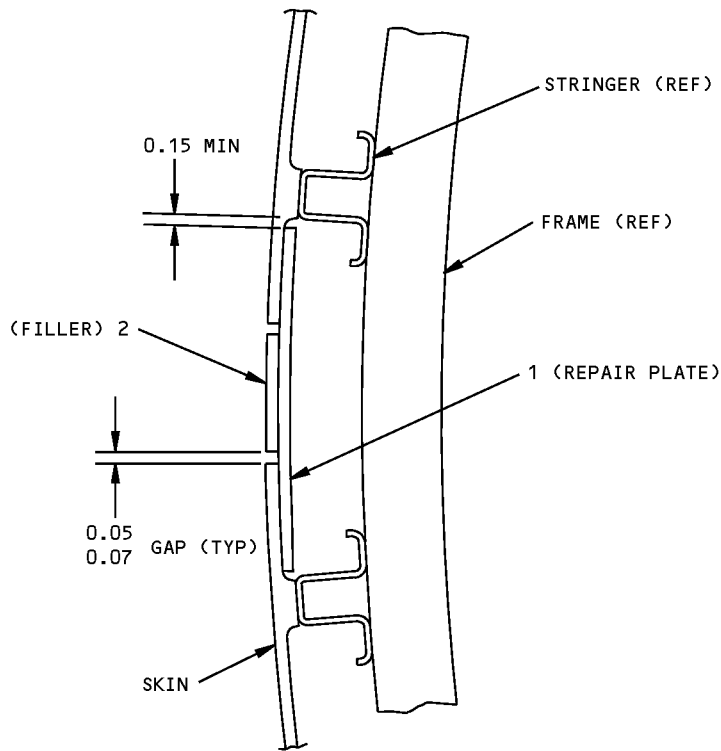
**Fuselage Skin - Flush Repair Between Stringers
Figure 201 (Sheet 2 of 4)**

**757-200
STRUCTURAL REPAIR MANUAL**



**Fuselage Skin - Flush Repair Between Stringers
Figure 201 (Sheet 3 of 4)**

**757-200
STRUCTURAL REPAIR MANUAL**



SECTION A-A

**Fuselage Skin - Flush Repair Between Stringers
Figure 201 (Sheet 4 of 4)**

STRUCTURAL REPAIR MANUAL

REPAIR 6 - REPAIR OF LIGHTNING STRIKE DAMAGE ON PRESSURIZED FUSELAGE SKIN

APPLICABILITY
THIS REPAIR IS FOR DAMAGE THAT IS LOCATED IN AN AREA OF CONSTANT THICKNESS. DAMAGE MUST ALSO BE AT LEAST 1.5 TIMES THE DAMAGE DIAMETER FROM A CHEM-MILLED RADIUS.

REPAIR INSTRUCTIONS

NOTE: Lightning strikes cause damage that looks like small burn marks. See Detail II.

Refer to section I for skin damage away from a fastener location. Refer to Section II for damage at a fastener location. Refer to Detail I for a flow chart.

SECTION I: REPAIR OF SKIN DAMAGE AWAY FROM A FASTENER LOCATION

1. Get access to the damaged area.
2. Examine the damaged area and find the depth and the length of the damage.
 - A. If the depth of the damage is less than the limits shown in the surface damage detail in SRM 53-00-01, allowable damage 1, refer to Section I, paragraph 3 or section I, paragraph 4 to repair the damage.
 - B. If the depth of the damage is more than the limits shown in the surface damage detail in SRM 53-00-01, allowable damage 1, and the damage is less than 0.3125-inch (7.94 mm) long, refer to section I, paragraph 3 to drill it out and install a rivet.
 - C. If the depth of the damage is more than the limits shown in the surface damage detail in SRM 53-00-01, allowable damage 1, and the damage is longer than 0.3125-inch (7.94 mm), see Table I for a doubler repair.
3. Drill out damage that is not longer than 0.3125 inch (7.94 mm) **B** as follows:
 - A. Use a drill bit with a diameter that is the same or larger than the length of the damage.
 - B. Do a nondestructive test to make sure there are no cracks **A**. As an alternative you can do a 10X magnified visual inspection as given in **F**.
 - C. Make the hole diameter 1/16-inch larger.

CAUTION: DO NOT MAKE THE COUNTERSINK DEPTH MORE THAN 70% OF THE SKIN THICKNESS. THE FASTENER FLUSHNESS MUST MEET FLUSHNESS REQUIREMENTS OF SRM 51-10-01, FIG. 3, TABLE III.

- D. Countersink the hole if necessary (refer to SRM 51-40-08). Remove all nicks, gouges, and sharp edges.
- E. Apply a chemical conversion coating to any bare aluminum surfaces. Refer to SRM 51-20-01.

CAUTION: BE CAREFUL WHEN YOU INSTALL LARGE DIAMETER RIVETS IN THIN SKINS. RIVET TOOLS CAN DENT, SCRATCH, OR GOUGE THE FUSELAGE SKIN.

- F. Install the rivet. The rivet must not be larger than 0.375 inch (9.52 mm) in diameter. See Detail III, IV, or V **D**.
 - G. Apply the finish to the repair area as necessary. Refer to AMM 51-21-10.
4. Repair damage that is less than the limits shown in the surface damage detail in SRM 53-00-01, allowable damage 1, as follows:
 - A. Blend out damage. Refer to the surface damage detail shown in SRM 53-00-01, allowable damage 1.
 - B. Make sure that the depth of blendout is not more than the limits shown in the surface damage detail in SRM 53-00-01, allowable damage 1.
 - C. Do a nondestructive test to make sure there are no cracks **A**. As an alternative you can do a 10X magnified visual inspection as given in **F**.
 - D. Apply a chemical conversion coating to any bare aluminum surfaces. Refer to SRM 51-20-01.
 - E. Apply the finish to the repair area as necessary. Refer to AMM 51-21-10.
 5. In the time limit given in **D**, replace blind rivets with 1/32-inch diameter oversize solid rivets as follows:
 - A. Remove the blind rivet.
 - B. Do a nondestructive test to make sure there are no cracks **A**.
 - C. Make the fastener hole larger so it agrees with the specifications for a 1/32-inch diameter oversize solid rivet. Refer to SRM 51-40-05. If the hole diameter for the 1/32-inch diameter oversize solid rivet is greater than 0.375 (9.52 mm), then refer to Fig. 208 for a small hole flush repair.
- CAUTION:** DO NOT MAKE THE COUNTERSINK DEPTH MORE THAN 70% OF THE SKIN THICKNESS. THE FASTENER FLUSHNESS MUST MEET FLUSHNESS REQUIREMENTS OF SRM 51-10-01, FIG. 3, TABLE III. DO NOT MICRO-SHAVE BLIND RIVETS.

**Repair of Lightning Strike Damage on Pressurized Fuselage Skin
Figure 201 (Sheet 1 of 8)**

STRUCTURAL REPAIR MANUAL

REPAIR INSTRUCTIONS (CONTINUED)

- D. If a flush head solid rivet is used, countersink the hole. If a protruding head solid rivet is used, use a countersink repair washer to fill any initial countersink in the skin (refer to SRM 51-40-08).
- E. Apply a chemical conversion coating to any bare aluminum surfaces. Refer to SRM 51-20-01.

CAUTION: BE CAREFUL WHEN YOU INSTALL LARGE DIAMETER RIVETS IN THIN SKINS. RIVET TOOLS CAN DENT, SCRATCH, OR GOUGE THE FUSELAGE SKIN.

- F. Install the rivet. The rivet must not be larger than 0.375 inch (9.52 mm) in diameter. Refer to Detail III or IV.
- G. Apply the finish to the repair area as necessary. Refer to AMM 51-21-10.

SECTION II

REPAIR OF LIGHTNING STRIKE DAMAGE AT A FASTENER LOCATION:

1. Get access to the damaged area.
2. Damage at a fastener location can be limited to the fastener or also include a part of the skin.

A. For fastener only damage, replace the fastener as given in Section II, paragraph 3 or 4.

B. For adjacent skin damage you can do one of the procedures that follow:

- Use a larger replacement fastener that would remove the skin damage as given in Section II Paragraph 3 or 4 or,
- Do a general skin repair as given in Table I.

3. Solid Fastener Repair **E**
For damage limited to a fastener, do steps A to E for a Category A repair. For damage at a fastener with adjacent skin damage, see step F.

A. Remove the initial fastener and make the hole 1/32 inch diameter larger. Refer to SRM 51-40-05.

CAUTION: DO NOT MAKE THE COUNTERSINK DEPTH MORE THAN 70% OF THE SKIN THICKNESS. THE FASTENER FLUSHNESS MUST MEET FLUSHNESS REQUIREMENTS OF SRM 51-10-01, FIGURE 3/GENERAL, TABLE III.

B. Countersink the hole if necessary. Refer to SRM 51-40-08. If a Briles rivet is used, refer to SRM 51-40-02 Figure 5/General for the installation of oversize Briles rivet in thin skin. Remove all nicks, gouges, and sharp edges.

C. Do a nondestructive test to make sure all the damage is removed **A**. As an alternative you can do a 10X magnified visual inspection as given in **F**. If more damage is found, get alternative repair instructions from Boeing.

CAUTION: BE CAREFUL WHEN YOU INSTALL LARGE DIAMETER RIVETS IN THIN SKINS. RIVET TOOLS CAN DENT, SCRATCH, OR GOUGE THE FUSELAGE SKIN

- D. Install the oversize fastener.
- E. Apply the finish to the fastener head as necessary. Refer to AMM 51-21-00.

F. For damage at a fastener with adjacent skin damage, it is permitted to repair the skin damage by increasing the replacement fastener one full size (1/16th inch). Do procedures in Section II, Paragraph 3 steps A thru E, provided the requirements that follow are met:

- The edge margin for the replacement fastener must be greater than 1.75D minimum or as specified in SRM 51-40-06.
- The replacement fastener spacing must be a minimum of 4D.

**Repair of Lightning Strike Damage on Pressurized Fuselage Skin
Figure 201 (Sheet 2 of 8)**

STRUCTURAL REPAIR MANUAL

REPAIR INSTRUCTIONS CONTINUED

4. Blind Fastener Repair

See Table III for limitations. For damage limited to a rivet, do steps A to E for a Category C repair with supplemental inspections as given in Table II.

NOTE: TO USE THIS REPAIR THE INITIAL FASTENER MUST BE A BACR15CE() OR A BACR15FV() RIVET WITH A MAXIMUM DIAMETER OF 6/32 INCH.

A. Remove the damaged rivet. Refer to SRM 51-40-02.

NOTE: INCREASING THE SIZE OF THE HOLE AS AN INSURANCE CUT IS NOT NECESSARY FOR THE BLIND FASTENER REPAIR. YOU WILL MAKE THE HOLE LARGER WHEN YOU SUBSEQUENTLY DO THE CATEGORY A REPAIR WITH A SOLID FASTENER.

B. Clean the hole and do a detail visual inspection of the hole with a minimum 10X magnification to make sure there are no cracks.

C. Apply a chemical conversion coating to the bare surfaces of the skin. Refer to SRM 51-20-01.

D. Install a protruding head blind fastener as given in Table III. **[G]**

E. Do the repeat inspections as given in Table II. Replace the repair with a solid rivet repair in the specified time limit given in Table II. Refer to Section II, paragraph 5.

5. Blind Fastener Replacement

In the time limit given in Table II, replace the blind fastener with an oversized solid rivet as follows:

A. Remove the blind fastener. Refer to SRM 51-40-02.

B. Do a non-destructive test to make sure there are no cracks. **[A]**

C. Make the hole diameter 1/16 inch larger for an oversized rivet installation. Refer to SRM 51-40-05.

CAUTION: DO NOT MAKE THE COUNTERSINK DEPTH MORE THAN 70% OF THE SKIN THICKNESS. THE FASTENER FLUSHNESS MUST MEET THE FLUSHNESS REQUIREMENTS OF SRM 51-10-01, FIGURE 3/GENERAL, TABLE III.

D. If a flush head solid rivet **[E]** is used, countersink the hole. If a protruding head solid **[C]** **[T]** rivet is used, use a countersink repair washer to fill initial countersink in the skin. Refer to SRM 51-40-08.

CAUTION: BE CAREFUL WHEN YOU INSTALL LARGE DIAMETER RIVETS IN THIN SKINS. RIVET TOOLS CAN DENT, SCRATCH OR GOUGE THE FUSELAGE SKIN.

E. Install the rivet.

F. Apply the finish to the repair area as necessary. Refer to AMM 51-20-00.

LENGTH OF DAMAGE	REPAIR
UP TO 1.00 INCH (25 mm)	FLUSH REPAIR - REPAIR 7 OPTIONAL: REPAIR 2, 3, 4, 5, 16, 17
LARGER THAN 1.00 INCH (25 mm)	USE EXTERNAL OR FLUSH REPAIR FOR LARGE DAMAGE - REPAIR 2, 3, 4, 5, 16, 17

TABLE I

NOTES

- D = FASTENER DIAMETER.
- REFER TO IDENTIFICATION 1 FOR FUSELAGE SKIN ALLOWABLE DAMAGE LIMITS.
- REFER TO THE FOLLOWING WHEN USING THIS REPAIR:
 - SRM 51-10-01 FOR AERODYNAMIC SMOOTHNESS REQUIREMENTS
 - SRM 51-10-02 FOR INSPECTION AND REMOVAL OF DAMAGE
 - SRM 51-20-01 FOR PROTECTIVE TREATMENT OF METAL
 - SRM 51-20-05 FOR REPAIR SEALING
 - SRM 51-40 FOR FASTENER CODE, REMOVAL, INSTALLATION, HOLE SIZES AND EDGE MARGINS
 - AMM 51-21-00 FOR INTERIOR AND EXTERIOR FINISHES.

[A] AN EDDY CURRENT INSPECTION FOR CRACKS IS RECOMMENDED. REFER TO NDT PART 6, 51-00-01 FOR EDDY CURRENT INSPECTIONS. FOR EXTERNAL SKIN DAMAGE ONLY, A PERMITTED ALTERNATIVE IS TO DYE-PENETRANT INSPECT. REFER TO SOPM 20-20-02.

[B] ANY HOLES MADE FOR THE REPAIR MUST NOT BE WITHIN 4 HOLE DIAMETERS FROM ANY OTHER HOLE, FASTENER, OR EDGE OF MATERIAL. IF A HOLE MADE FOR THE REPAIR IS CLOSER THAN ALLOWED, USE AN EXTERNAL OR FLUSH REPAIR (SEE TABLE I).

**Repair of Lightning Strike Damage on Pressurized Fuselage Skin
Figure 201 (Sheet 3 of 8)**

STRUCTURAL REPAIR MANUAL

NOTES (CONTINUED)

- C** FASTENER HEADS WHICH ARE ABOVE THE OUTER MOLD LINE OF THE SKIN ARE NOT PERMITTED NEAR THE STATIC PRESSURE PORTS. REFER TO SRM 51-10-01.
- D** A REPAIR USING BLIND FASTENERS IS A CATEGORY C REPAIR.

NOTE: REFER TO REPAIR GENERAL, FOR THE DEFINITION OF FUSELAGE REPAIR ZONES.

 1. FOR REPAIR ZONES A AND B, THE CATEGORY C REPAIR HAS FAA APPROVAL IF YOU OBEY THE CONDITIONS THAT FOLLOW:
 - BLIND RIVETS MUST BE INSPECTED AT OR BEFORE 2500 FLIGHT CYCLE INTERVALS AFTER INSTALLATION.
 - LOOSE OR MISSING FASTENERS MUST BE REPLACED WITH SOLID RIVETS
 - BLIND RIVETS MUST BE REPLACED WITH SOLID RIVETS NO LATER THAN 12,000 FLIGHT CYCLES. REFER TO SECTION I, PARAGRAPH 5.
 2. FOR REPAIR ZONE C, THE CATEGORY C REPAIR HAS FAA APPROVAL IF YOU OBEY THE CONDITIONS THAT FOLLOW:
 - THE DAMAGE MUST NOT BE:
 - INSTALLED THROUGH ANY SUBSTRUCTURE (STRINGER, TEAR STRAP, BEAR STRAP, ETC.)
 - AT A SKIN SPLICE
 - WITHIN 20 INCHES (50.8 mm) OF A SKIN CUTOUT
 - WITHIN 1.0 INCH (25 mm) OF AN EXISTING FASTENER
 - BLIND FASTENERS USED MUST BE PROTRUDING HEAD BACR15FR*E OR NAS1738E*
 - MAXIMUM BLIND RIVET SIZE USED IS 3/16 INCH DIAMETER
 - A MAXIMUM OF 3 REPAIRS IS ALLOWED PER STRINGER/ FRAME BAY WITH ADJACENT REPAIRS SEPARATED BY A MINIMUM OF 4D.
 - AT OR BEFORE 1000 FLIGHT CYCLE INTERVALS DO DETAILED VISUAL INSPECTIONS AFTER INSTALLATION.
 - BLIND RIVETS MUST BE REPLACED WITH SOLID RIVETS NO LATER THAN 3,000 FLIGHT CYCLES OR 24 MONTHS, WHICH EVER COMES FIRST.
 - REPLACE BLIND RIVETS WITH SOLID RIVETS AS GIVEN IN SECTION I, PARAGRAPH 5 EXCEPT THAT THE REPLACEMENT RIVET MUST BE A PROTRUDING HEAD BACR15FT*AD RIVET WITH A MAXIMUM SIZE OF 9/32 INCH DIAMETER.

- E** REPLACE THE INITIAL FASTENER WITH THE SAME FASTENER TYPE.
- F** AS AN ALTERNATIVE INSPECTION METHOD, YOU CAN DO A 10X MAGNIFIED VISUAL INSPECTION IF:
 - AN EXTERNAL DETAILED VISUAL INSPECTION OF THE AREA IS DONE AT INTERVALS OF NOT MORE THAN 500 FLIGHT CYCLES.
 - THERE IS ONLY ONE DAMAGE ALONG A ROW OF FASTENERS WITHIN 20 INCHES (50.8 mm).
 - THERE IS ONLY ONE DAMAGE WITHIN A SINGLE SKIN BAY.
 - AT OR BEFORE 3000 FLIGHT CYCLES OR WITHIN 24 MONTHS, WHICHEVER COMES FIRST, FROM THE TIME OF INITIAL DETECTION OF THE DAMAGE, DO AS FOLLOWS:
 1. FOR A BLIND FASTENER OR SOLID FASTENER REPAIR AWAY FROM EXISTING FASTENERS; REMOVE THE FASTENER, DO AN OPEN HOLE EDDY CURRENT INSPECTION, OVERSIZE THE HOLE BY 1/16 INCHES, AND INSTALL AN OVERSIZE SOLID FASTENER REPAIR AS GIVEN IN SECTION I, PARAGRAPH 3. REFER TO NDT PART 6, 51-00-16 FOR THE EDDY CURRENT INSPECTION.
 2. FOR A BLENDOUT REPAIR; DO A NON-DESTRUCTIVE TEST TO MAKE SURE THERE ARE NO CRACKS. **A**
 3. FOR A SOLID FASTENER REPAIR AT AN EXISTING FASTENER LOCATION; REMOVE THE FASTENER, DO AN OPEN HOLE EDDY CURRENT INSPECTION; OVERSIZE THE HOLE BY 1/16 INCH; AND INSTALL AN OVERSIZED FASTENER WHICH MEETS THE REQUIREMENTS OF SECTION II, PARAGRAPH 3. MAKE SURE THAT THE FINAL FASTENER SIZE WILL HAVE A MINIMUM OF 3D FASTENER SPACING AND A MINIMUM EDGE MARGIN OF 1.5D ON ALL ATTACHED PARTS. REFER TO NDT PART 6, 51-00-16 FOR THE EDDY CURRENT INSPECTION.
- G** INSTALL A COUNTERSINK REPAIR WASHER AS GIVEN IN SRM 51-40-08.
- H** REFER TO SRM 53-00-01, REPAIR GENERAL FOR THE DEFINITION OF REPAIR ZONES.
- I** USE A BACR15FT*D PROTRUDING HEAD RIVET IF THE FLUSH HEAD RIVET COUNTERSINK DEPTH WOULD EXCEED 70% OF THE SKIN THICKNESS.

Repair of Lightning Strike Damage on Pressurized Fuselage Skin
Figure 201 (Sheet 4 of 8)



**757-200
STRUCTURAL REPAIR MANUAL**

SECTION II, CATAGORY C REPAIR INSPECTION AND REPAIR REQUIREMENTS				
DAMAGE LOCATION	INSPECTION THRESHOLD	REPEAT INSPECTION ALTERNATIVES		TIME LIMIT TO DO THE CATAGORY A REPAIR
		METHOD	INTERVAL	
ZONE A H	1,000 CYCLES	10 X MAGNIFIED DETAIL VISUAL INSPECTION	1,000 CYCLES	3,000 FLIGHT CYCLES NOT TO EXCEED 24 MONTHS
ZONE B AND C H	500 CYCLES	10 X MAGNIFIED DETAIL VISUAL INSPECTION	500 CYCLES	1,000 FLIGHT CYCLES NOT TO EXCEED 24 MONTHS

NOTE: INSPECT THE SKIN AROUND THE HOLE FOR THE CRACKS. LOOSE OR MISSING FASTENERS MUST BE REPLACED WITH SOLID FASTENERS.

TABLE II – SECTION II CATAGORY C REPAIR INSPECTION AND REPAIR REQUIREMENTS

DAMAGED FASTENER	BLIND FASTENER	COMMENTS
BACR15FV()KE OR, BACR15CE()D, KE, AD	MS90354() G BACR15FR()E G	PROTRUDING HEAD REPAIR FASTENERS

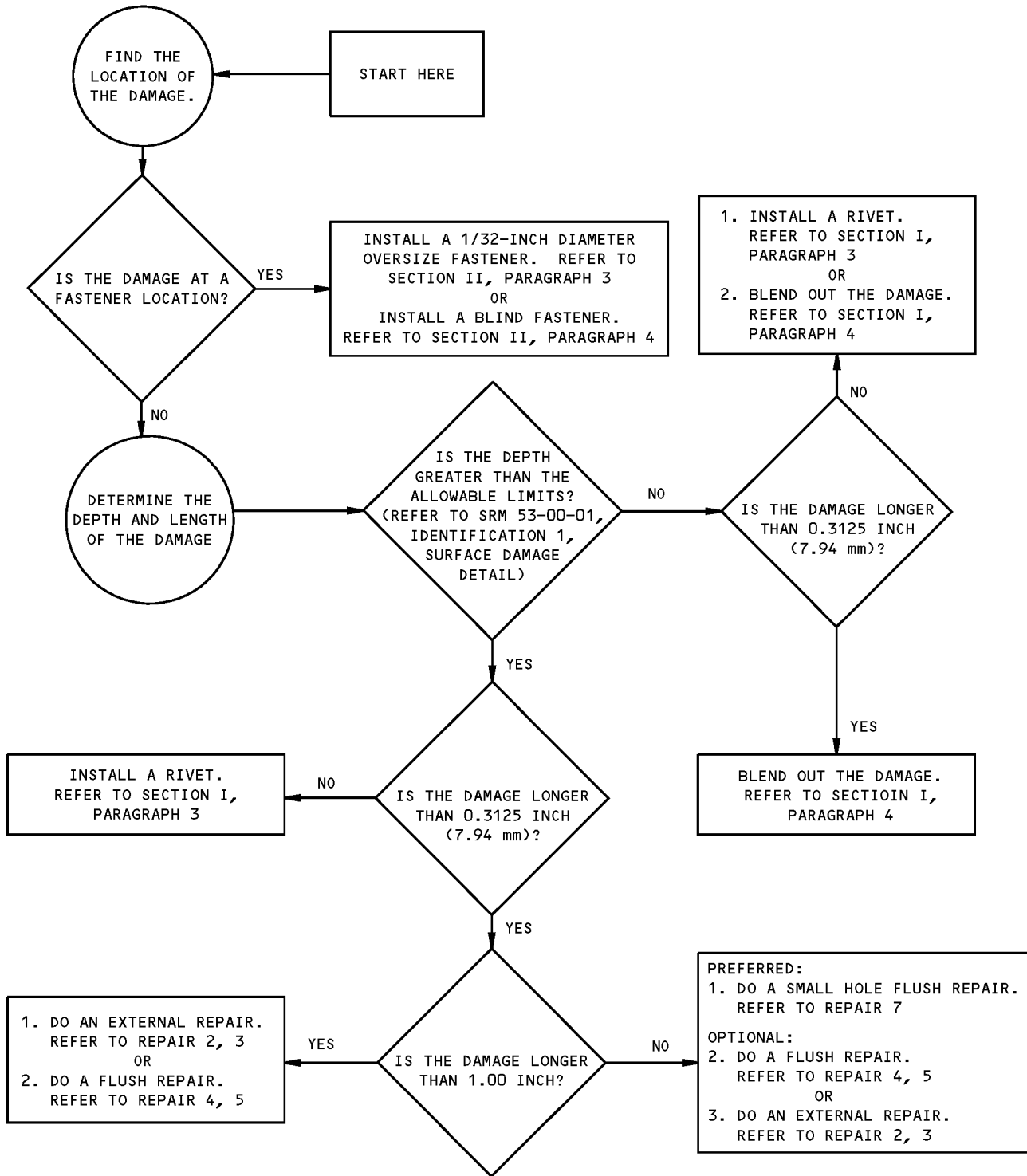
NOTES

- BLIND FASTENER REPAIRS ARE PERMITTED AS FOLLOWS:
 - THE DAMAGE MUST NOT BE WITHIN 20 INCHES (51 mm) OF SKIN CUTOUT.
 - THE DAMAGE MUST NOT BE AT A SKIN OR STRINGER SPLICE.
 - A MAXIMUM OF 2 FASTENERS WITHIN 20 INCHES (51 mm) IN THE LONGITUDINAL DIRECTION.
 - A MAXIMUM OF ONE FASTENER ON A SHEAR TIE BETWEEN STRINGERS. NO BLIND FASTENERS ARE PERMITTED AT THE END LOCATIONS OF A SHEAR TIE.
 - BLIND FASTENER REPAIRS ARE PERMITTED ONLY TO THE AREAS IN WHICH THE SKIN THICKNESS IS EQUAL TO OR LESS THAN 0.080 INCH (2.03 mm) AND IN WHICH THE INITIAL FASTENER IS EQUAL TO OR LESS THAN 6/32 INCH DIAMETER.
- DO NOT USE PROTRUDING HEAD FASTENERS NEAR STATIC PORTS AND ANGLE OF ATTACK SENSORS. REFER TO SRM 51-10-01, FIGURE 7/GENERAL.
- MAKE SURE THE EDGE MARGINS WITH THE OVERSIZED HOLES ARE 1.75D MINIMUM OR AS SPECIFIED IN SRM 51-40-06, WHICH EVER IS LESS.

TABLE III REPAIR WITH BLIND FASTENER FOR DAMAGED
INITIAL BACR15CE() AND BACR15FV() RIVETS

**Repair of Lightning Strike Damage on Pressurized Fuselage Skin
Figure 201 (Sheet 5 of 8)**

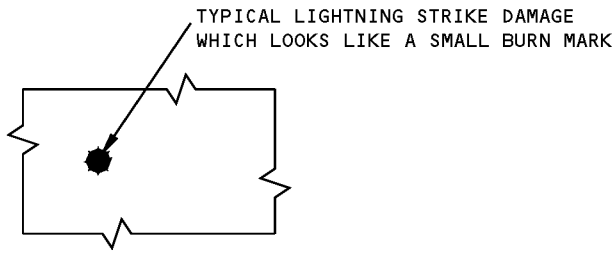
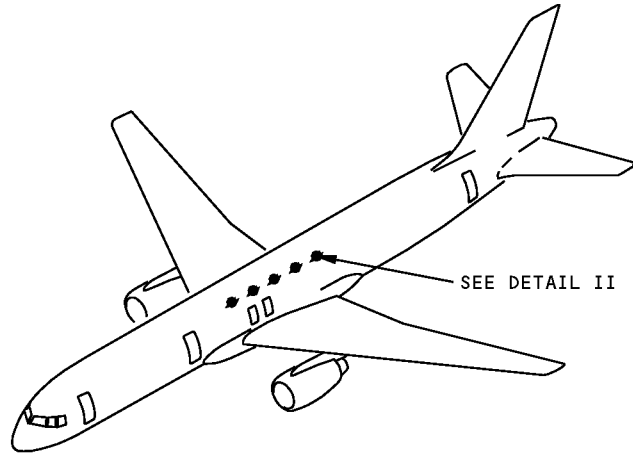
**757-200
STRUCTURAL REPAIR MANUAL**



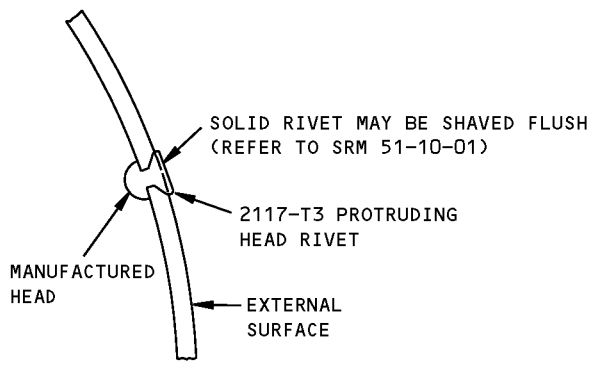
FLOW CHART FOR THE REPAIR PROCEDURE
DETAIL I

**Repair of Lightning Strike Damage on Pressurized Fuselage Skin
Figure 201 (Sheet 6 of 8)**

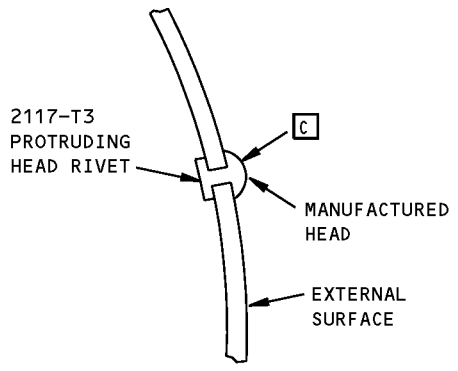
**757-200
STRUCTURAL REPAIR MANUAL**



DETAIL II



RECOMMENDED METHOD

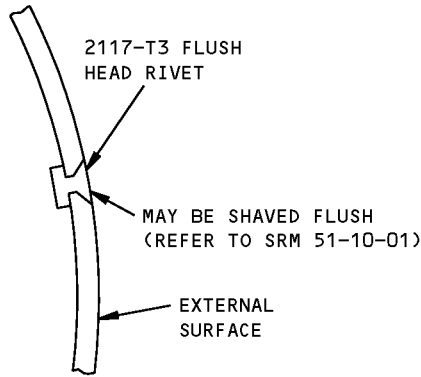


ALTERNATIVE METHOD

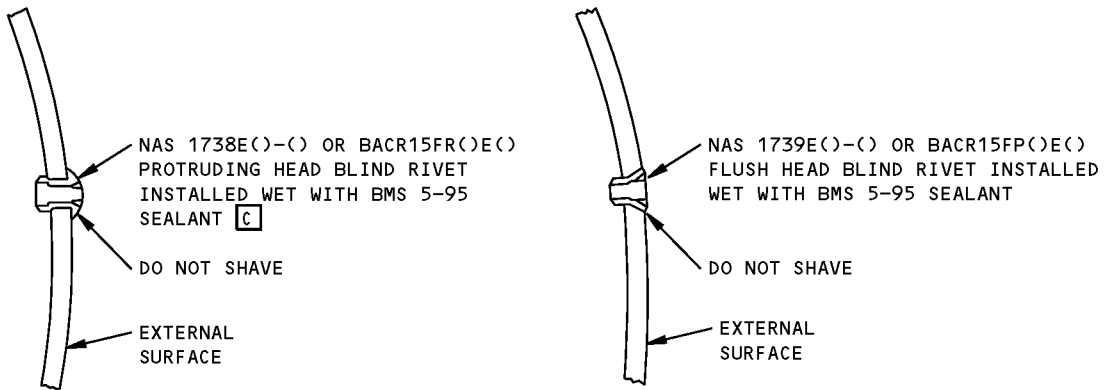
DETAIL III

**Repair of Lightning Strike Damage on Pressurized Fuselage Skin
Figure 201 (Sheet 7 of 8)**

**757-200
STRUCTURAL REPAIR MANUAL**



DETAIL IV



**FOR USE IN AREAS WITHOUT EASY ACCESS
FOR INTERNAL INSTALLATION**

DETAIL V **D**

**Repair of Lightning Strike Damage on Pressurized Fuselage Skin
Figure 201 (Sheet 8 of 8)**

**757-200
STRUCTURAL REPAIR MANUAL**

REPAIR 7 - FUSELAGE SKIN - SMALL HOLE FLUSH REPAIR

REPAIR INSTRUCTIONS

1. Clean out damaged hole to 1-inch max diameter circle. Distance from the center of hole to an edge or cutout must not be less than 4 times the diameter of hole.
2. Fabricate repair parts.
3. Assemble repair parts and drill fastener holes.
4. Remove repair parts.
5. Break sharp edges of original and repair parts 0.015 R to 0.030 R.
6. Remove all nicks, scratches, burrs, sharp edges and corners from original and repair parts.
7. Alodize the repair parts and raw edges of original parts.
8. Apply one coat of BMS 10-11, type 1 primer to all of part 2 and to the raw edges and inner surface of part 1 in accordance with 51-21 of the Maintenance Manual.
9. Install repair parts, making a faying surface seal with BMS 5-95 sealant. Install the rivets without sealant. BACR15FV rivets should never be installed with sealant.
10. Fill gap between parts with aerodynamic smoother.
11. Restore finish.

NOTES

- THIS IS A CATEGORY A REPAIR FOR 757-SF AIRPLANES. THE INSPECTIONS GIVEN IN THE MAINTENANCE PLANNING DATA (MPD) ARE SUFFICIENT TO MAINTAIN THE DAMAGE TOLERANCE OF THE INITIAL STRUCTURE WITH THIS REPAIR INSTALLED. REFER TO SRM 51-00-06 FOR REPAIR CATEGORIES AND DEFINITIONS.
- THIS REPAIR MUST NOT BE USED IN AN AREA WITH EXISTING DOUBLERS OR INTEGRAL PAD
- REFER TO THE FOLLOWING WHEN MAKING THIS REPAIR:
 - 51-10-01 FOR AERODYNAMIC SMOOTHNESS REQUIREMENTS
 - 51-10-02 FOR INSPECTION AND REMOVAL OF DAMAGE
 - 51-20-01 FOR PROTECTIVE TREATMENT OF METAL
 - 51-20-05 FOR SEALING OF REPAIRS
 - 51-21 OF THE MAINTENANCE MANUAL FOR INTERIOR AND EXTERIOR FINISHES
 - 51-31 OF THE MAINTENANCE MANUAL FOR SEALS AND SEALING
 - 51-40 FOR FASTENER CODE, REMOVAL, INSTALLATION, HOLE SIZES AND EDGE MARGINS
 - 53-01-04 OF THE MAINTENANCE MANUAL FOR INSTALLATION AND REMOVAL OF ACOUSTIC TILE.

- A** DISTANCE FROM THE CENTER OF HOLE TO AN EDGE OR CUTOUT MUST NOT BE LESS THAN 4 TIMES DIAMETER OF HOLE.
- B** FOR SKINS IN SECTIONS 41 AND 48.
- C** FOR SKINS IN SECTIONS 43, 45 AND 46.
- D** MINIMUM DISTANCE BETWEEN EDGES OF ADJACENT REPAIR DOUBLERS MUST NOT BE LESS THAN 0.20.

SYMBOLS

-  REPAIR FASTENER LOCATION.

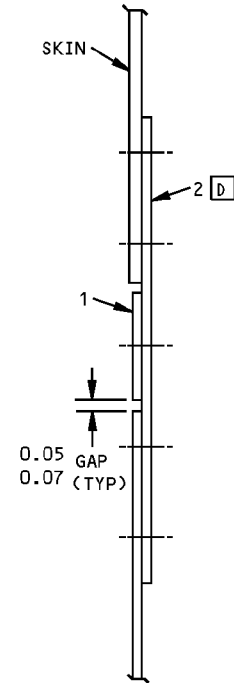
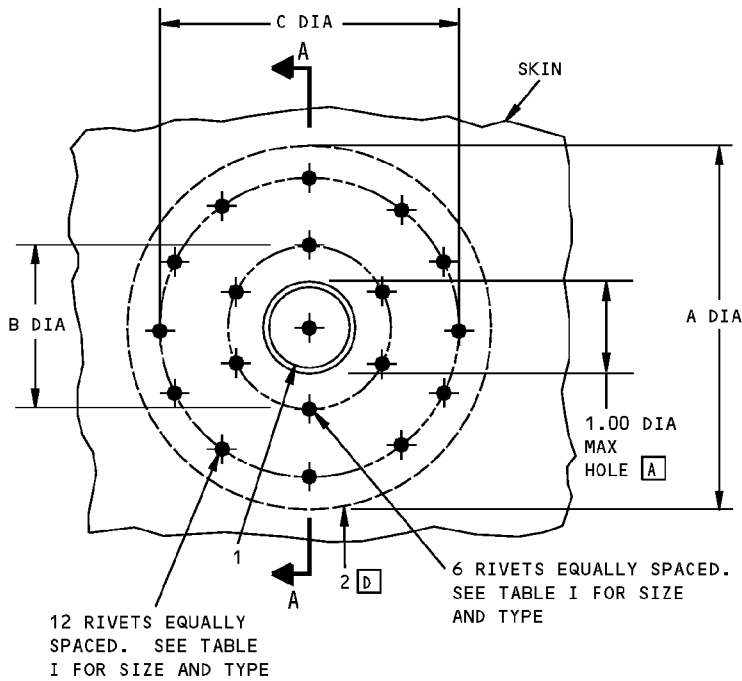
REPAIR MATERIAL			
PART		QTY	MATERIAL
1	FILLER	1	SAME MATERIAL GAGE AND HEAT TREAT AS ORIGINAL SKIN.
2	DOUBLER	1	SAME MATERIAL AND HEAT TREAT AS ORIGINAL SKIN. SEE TABLE I FOR GAGE.

**Fuselage Skin - Small Hole Flush Repair
Figure 201 (Sheet 1 of 2)**

**757-200
STRUCTURAL REPAIR MANUAL**

SKIN GAGE	PART 2 (DOUBLER) GAGE	A DIA	B DIA	C DIA	RIVET SIZE	RIVET TYPE
0.040	0.056	3.80	1.80	3.10	5/32	BACR15BB()D
0.047	0.063	3.80	1.80	3.10	5/32	
0.056	0.063	3.80	1.80	3.10	5/32	BACR15CE()D B BACR15FV()KE C
0.063	0.071	4.30	2.00	3.50	3/16	
0.071	0.080	4.30	2.00	3.50	3/16	
0.080	0.090	5.25	2.25	4.25	1/4	
0.080	0.100	5.25	2.25	4.25	1/4	

TABLE I



SECTION A-A

**Fuselage Skin - Small Hole Flush Repair
Figure 201 (Sheet 2 of 2)**

STRUCTURAL REPAIR MANUAL

REPAIR 8 - FUSELAGE SKIN REPAIR NEAR THE PRIMARY STATIC PORTS

APPLICABILITY
THIS REPAIR IS APPLICABLE TO PASSENGER AIRPLANES ONLY.

NOTES

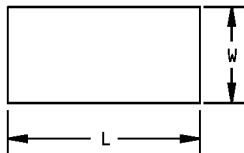
- REPAIRS DIFFER DEPENDING ON LOCATION OF DAMAGE. SEE DETAIL I FOR DEFINITIONS OF REPAIR ZONES.
- FOR SKIN REPAIRS NEAR AIR DATA SENSORS (OTHER THAN THE PRIMARY STATIC PORTS), REFER TO SRM 51-10-01, REPAIR 6.
- WHEN YOU USE THIS REPAIR REFER TO:
 - AMM 11-21-21 FOR PLACARDS AND MARKINGS
 - AMM 34-11-03 FOR REMOVAL AND INSTALLATION OF STATIC PORTS
 - AMM 51-21 FOR INTERIOR AND EXTERIOR FINISHES
 - SOPM 20-20-02 FOR PENETRANT INSPECTION METHODS
 - SRM 51-10-01 FOR AERODYNAMIC SMOOTHNESS REQUIREMENTS
 - SRM 51-10-02 FOR INSPECTION AND REMOVAL OF DAMAGE
 - SRM 51-20-01 FOR PROTECTIVE TREATMENT OF METAL
 - SRM 51-20-05 FOR SEALING OF FUSELAGE SKIN REPAIRS
 - SRM 51-40 FOR FASTENER CODE, INSTALLATION AND REMOVAL, HOLE SIZES AND EDGE MARGINS
 - SRM 51-40-08 FOR COUNTERSINK WASHERS.

REPAIR INSTRUCTIONS

1. Return all indented or projecting skin to contour.
2. Penetrant inspect surface for cracks. If cracks are found, stop drill to a diameter of 0.25 inch (6 mm) , or remove damaged skin using a 0.50 inch (13 mm) minimum corner radius. A filler is necessary if damage is at a stringer location. See Repair 2 for filler and surface treatment. **[A]**
3. For Zone 1 repairs, do the steps that follow:
 - A. Remove and discard static ports.
 - B. Increase the diameter of the initial static port hole for a 232N9104-1 washer.
 - C. Make the repair doubler and drill the fastener holes. See Detail VI for the countersink in the repair doubler at the static port.
4. Apply a chemical conversion coating to the repair parts and to the bare surfaces of the remaining skin. Refer to SRM 51-20-01.
5. Apply one layer of BMS 10-11, Type I primer and one layer of BMS 10-11, Type II enamel to the mating surfaces. Refer to SOPM 20-41-02.
6. Install the repair parts with BMS 5-95 sealant between the mating surfaces.
7. Install the fasteners. Do not use sealant to install the BACR15FV (Briles) rivet.
8. A bead of sealant will be squeezed out, around the repair, at the edges. Make the bead into a fillet. Add more sealant to make the fillet seal, if necessary.
9. Install the new static port assembly and microshave flush with the doubler to +0.003/-0.000 inch (+0.076 mm/-000 mm) (for Zone 1 repairs only).
10. Restore the surface finish. Refer to AMM 51-21.

[A] FOR ALL LINE NUMBERS THAT ARE NOT 154 THRU 204: DO A DETAILED, INTERNAL VISUAL INSPECTION OF THE SKIN IN THE REPAIR AREA, SPECIALLY AT THE OUTERMOST FASTENER ROW OF THE DOUBLER. DO THE INSPECTION WHEN THE AIRFRAME HAS 37,500 FLIGHT CYCLES, AND DO THE INSPECTION AGAIN EACH 12,000 FLIGHT CYCLES. **[F]**

FOR LINE NUMBERS 154 THRU 204: DO AN EXTERNAL, LOW FREQUENCY, EDDY CURRENT INSPECTION OF THE SKIN THAT IS UNDER THE REPAIR DOUBLER. DO THE INSPECTION AT THE OUTERMOST FASTENER ROW OF THE DOUBLER. DO THE INSPECTION WHEN THE AIRFRAME HAS 37,500 FLIGHT CYCLES, AND DO THE INSPECTION AGAIN EACH 4900 FLIGHT CYCLES. **[F]**



REPAIR DIMENSIONS

**Fuselage Skin Repair Near the Primary Static Ports
Figure 201 (Sheet 1 of 6)**

STRUCTURAL REPAIR MANUAL

NOTES (CONT)

- B** THE FOLLOWING RESTRICTIONS APPLY:
- EXTERNAL REPAIRS ONLY
 - NO REPAIR EDGES WITHIN THIS ZONE (I.E. ANY REPAIR WHICH ENTERS THE ZONE MUST COVER AT LEAST THE ENTIRE ZONE)
 - REPAIRS COVERING THIS ZONE MUST HAVE $L \geq 2.2W$
 - NO TAPERED SHIMS MAY ENTER THIS ZONE.
 - IN ADDITION TO THE ABOVE LIMITS, THE FOLLOWING NOTE APPLIES:

AFTER INSTALLATION, THE SURFACE OF THE SKIN AND PORT FOR A DISTANCE 3 INCHES FORWARD AND AFT OF THE PORT CENTERLINE SHALL BE FLUSH WITHIN 0.010 INCH (0.25 mm) MAXIMUM, MEASURED AS THE CLEARANCE BETWEEN THIS SURFACE AND THE EDGE OF A 6-INCH STRAIGHTEDGE THAT IS PLACED HORIZONTALLY AGAINST THE SURFACE. AS AN ALTERNATIVE, YOU CAN USE THE AVERAGE MEASUREMENT PROCEDURE AS GIVEN IN AMM 51-10-00-6. FOR RVSM OPERATION, YOU MUST USE THE AVERAGE MEASUREMENT PROCEDURE AS GIVEN IN AMM 51-10-00-6. THE SKIN WAVINESS MUST BE LESS THAN THE LIMIT OF ± 0.010 (± 0.25 mm) INCH WHEN MEASURED WITH THIS AVERAGE MEASUREMENT PROCEDURE.

- C** THE FOLLOWING RESTRICTIONS APPLY:
- ANY REPAIR WHICH ENTERS ZONE 2 MUST SPAN THE ENTIRE LENGTH OF THE ZONE
 - REPAIRS ENTERING THE ZONE MUST HAVE $L > W$
 - EXTERNAL REPAIRS ARE PERMITTED
 - FLUSH REPAIRS ARE PERMITTED IF THE TAPERED SHIMS END AT LEAST 2 INCHES AWAY FROM THE BORDER WITH ZONE 1. TAPERED SHIMS MUST HAVE AT LEAST A 50:1 TAPER RATIO
 - USE FLUSH FASTENERS ONLY.

- D** THE FOLLOWING RESTRICTIONS APPLY:
- EXTERNAL REPAIRS ARE PERMITTED
 - FLUSH REPAIRS ARE PERMITTED IF THE TAPERED SHIMS END AT LEAST 2 INCHES AWAY FROM ZONE 1. TAPERED SHIMS MUST HAVE AT LEAST A 50:1 TAPER RATIO
 - USE FLUSH FASTENERS ONLY.

- E** ALL RIVETS WITHIN A 3-INCH (76 mm) RADIUS OF THE STATIC PORT HOLE MUST BE FLUSH WITH THE DOUBLER, WITHIN 0.003 INCH (0.076 mm) MAXIMUM. MAKE THE FASTENER SPACING 2.0 TO 3.0 INCHES (50 mm to 76 mm) IN THE CIRCUMFERENTIAL AND LONGITUDINAL DIRECTIONS.

- F** THIS REPAIR HAS FAA APPROVAL CONTINGENT ON ACCOMPLISHMENT OF THE INSPECTIONS AT THE INTERVALS CONTAINED HEREIN.

- G** FOR RVSM OPERATION, A MAXIMUM OF TWO EXTERNAL REPAIRS, OR TWO INTERNAL REPAIRS THAT EXTEND ACROSS A FRAME OR STRINGER, ARE PERMITTED IN THE AREA OF THE PRIMARY STATIC PORTS. THE TWO REPAIRS CAN BE ON ONE SIDE OF THE AIRPLANE, OR ONE REPAIR CAN BE ON EACH SIDE. THESE LIMITS ARE BASED ON MAINTAINING SATISFACTORY PERFORMANCE OF THE PRIMARY ALTIMETRY SYSTEM.

- H** BETWEEN THE DOUBLER AND THE SKIN USE COUNTERSINK WASHERS IN THE INITIAL COUNTERSINK HOLES. REFER TO SRM 51-40-08. ALTERNATIVELY, REFER TO SRM 53-00-01, REPAIR 1, TO USE THE BRILES RIVET HEAD AS A REPAIR WASHER.

FASTENER SYMBOLS

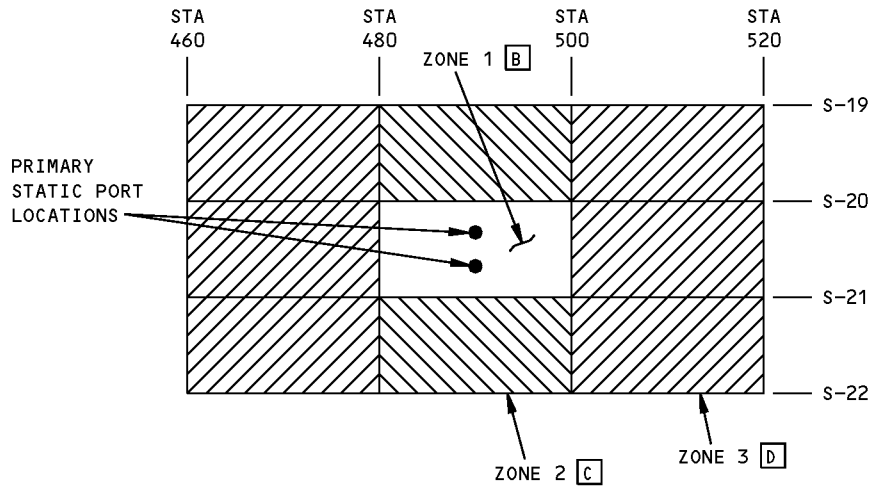
- + INITIAL FASTENER LOCATION.
- ✦ INITIAL FASTENER LOCATION. INSTALL BACR15FV6KE* BRILES, 120 DEGREE HEAD RIVET, SAME SPACING, TYPE AND DIAMETER AS THE INITIAL FASTENER.
- ⊕ REPAIR FASTENER LOCATION. BACR15FV6KE* BRILES, 120 DEGREE HEAD RIVET.

REPAIR MATERIAL			
	PART	QTY	MATERIAL
1	REPAIR DOUBLER	1	0.063 2024-T3 CLAD
2	WASHER	AS REQ'D	232N9104-1 WASHER AS REQUIRED FOR REINSTALLATION
3	WASHER	AS REQ'D	65-60419-3 WASHER AS REQUIRED FOR REINSTALLATION

TABLE I

**Fuselage Skin Repair Near the Primary Static Ports
Figure 201 (Sheet 2 of 6)**

**757-200
STRUCTURAL REPAIR MANUAL**

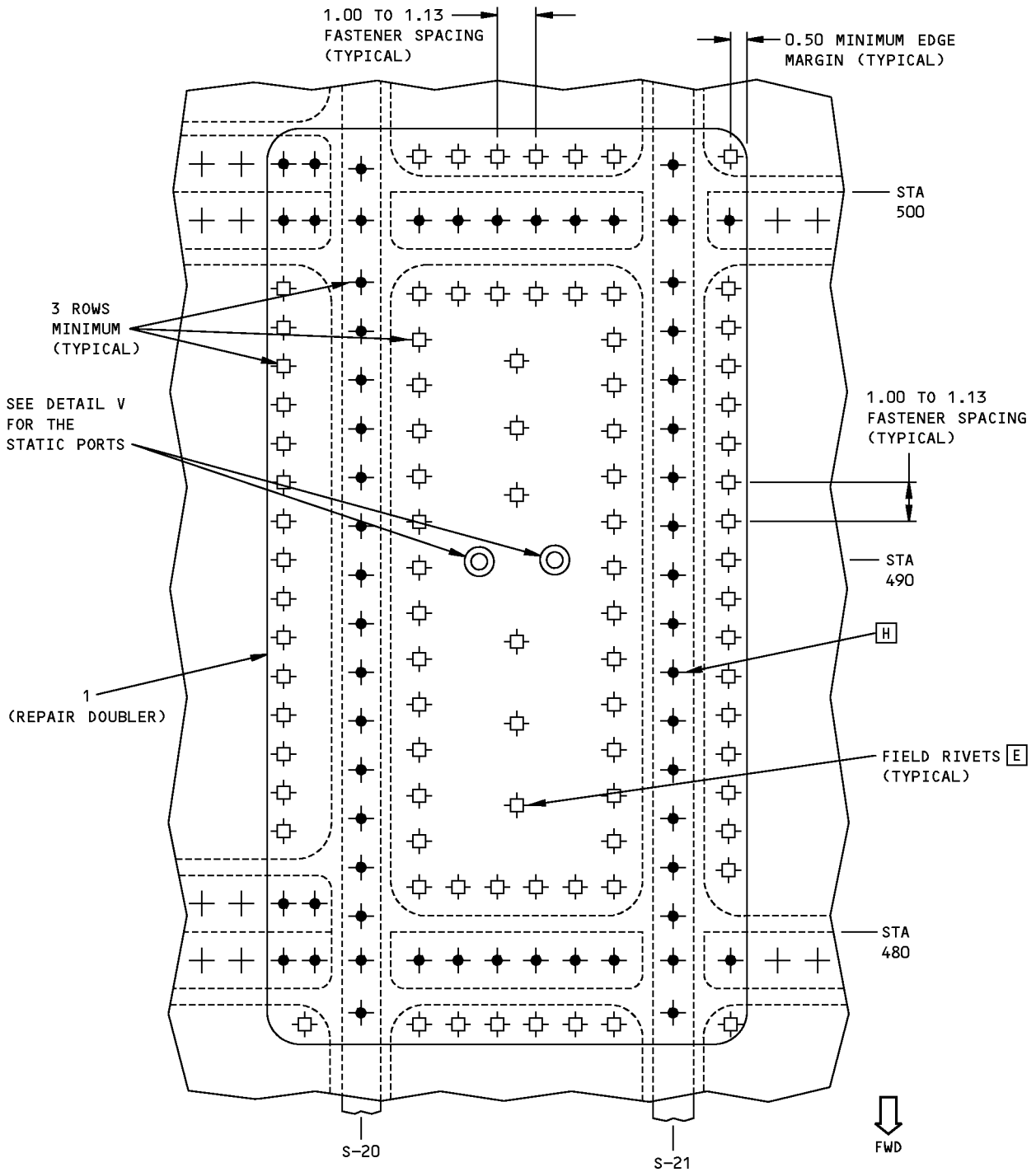


REPAIR ZONES F G
DETAIL I

- REPAIR ZONE 1 B E
- REPAIR ZONE 2 C
- REPAIR ZONE 3 D

**Fuselage Skin Repair Near the Primary Static Ports
Figure 201 (Sheet 3 of 6)**

STRUCTURAL REPAIR MANUAL

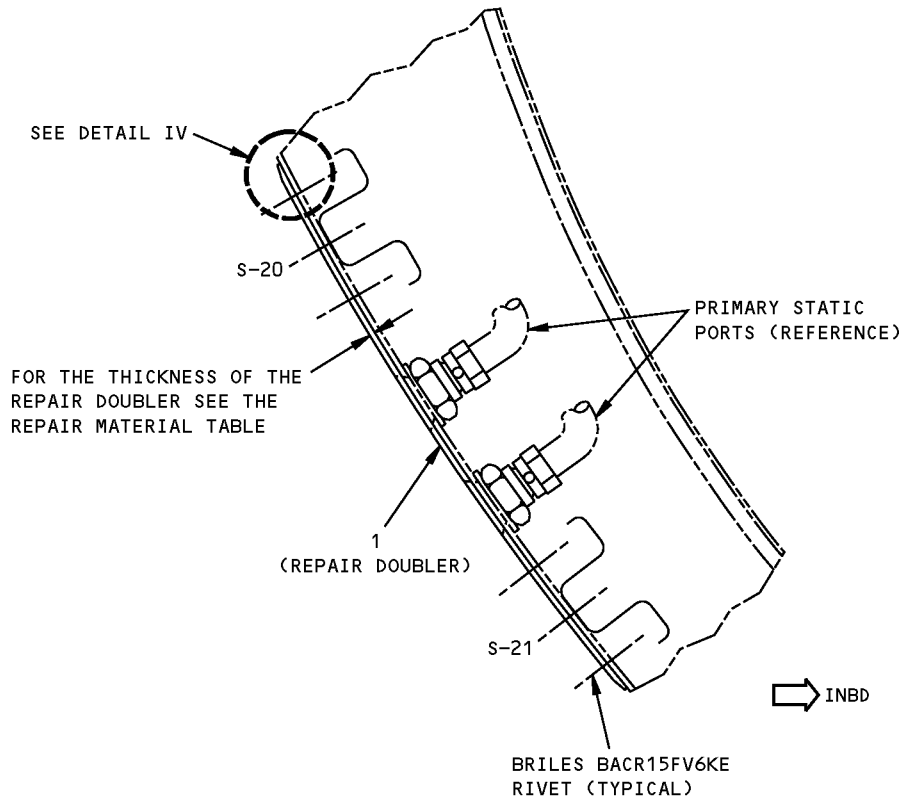


EXTERNAL SKIN REPAIR NEAR THE PRIMARY STATIC PORTS ZONE 1 REPAIR IS SHOWN
DETAIL II

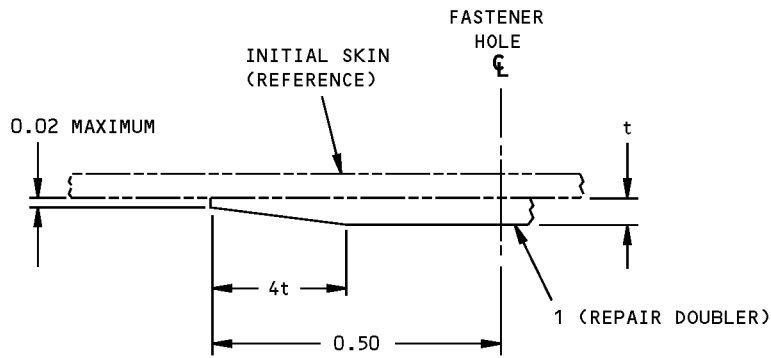
591239 S0006801533_V2

Fuselage Skin Repair Near the Primary Static Ports
Figure 201 (Sheet 4 of 6)

**757-200
STRUCTURAL REPAIR MANUAL**



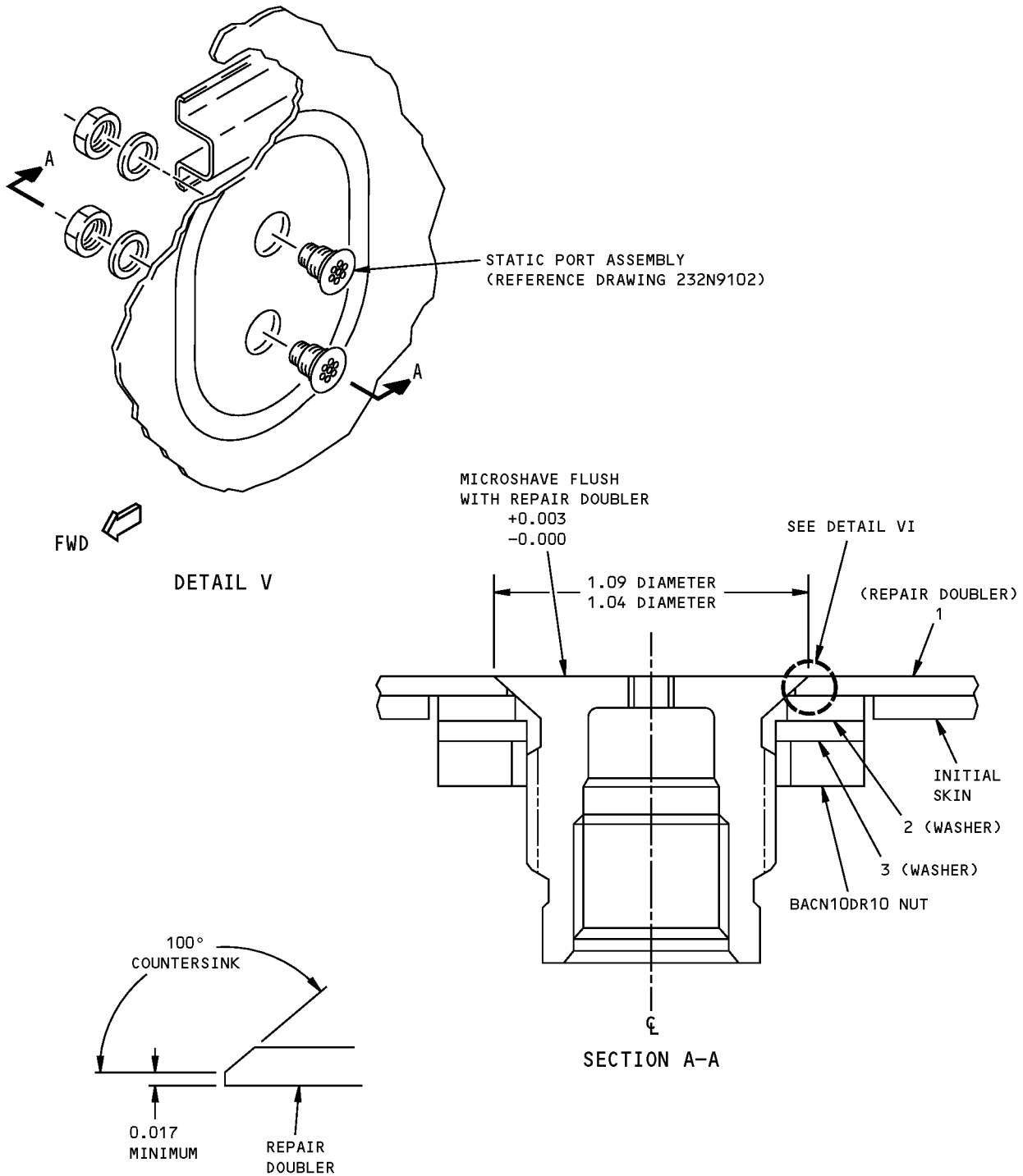
DETAIL III



**TYPICAL ALL EDGES
DETAIL IV**

**Fuselage Skin Repair Near the Primary Static Ports
Figure 201 (Sheet 5 of 6)**

**757-200
STRUCTURAL REPAIR MANUAL**



(ONLY THE REPAIR DOUBLER IS SHOWN)
DETAIL VI

**Fuselage Skin Repair Near the Primary Static Ports
Figure 201 (Sheet 6 of 6)**

STRUCTURAL REPAIR MANUAL**REPAIR 9 - FUSELAGE SKIN CREASE REPAIR AT BS 600 BETWEEN STRINGERS 27L AND 27R****REPAIR INSTRUCTIONS**

1. If necessary, remove the initial shear tie from the skin and the frame so that you can do step 2.
2. Carefully put the skin back to its correct contour.
3. Examine the damaged area to make sure that there are no cracks in the skin. Examine the shear ties and the frame for cracks. Use the eddy current inspection procedure. Refer to NDT Part 6, 51-00-01. If there is only external damage to the skin, a satisfactory alternative is the dye penetrant inspection procedure. Refer to SOPM 20-20-02.
4. Get the repair parts or make the equivalent repair parts. Put a radius on the edge of the part 4 filler where it will nest in the chem-milled step. See Detail I and Table I.
5. Assemble the repair parts and drill the fastener holes. Backdrill through the initial fastener holes, if possible. Keep a minimum edge margin of 1.7D on all parts and a minimum edge margin of 1D on all chem-milled steps. Make sure the fastener heads are not in the radius of the chem-milled step or the shear tie. Countersink the fastener holes on the external side of the skin. Do not countersink more than 70% of the skin thickness. This will prevent knife-edging of the skin. Microshave the fastener head that is above the skin surface. Do not countersink the fastener holes if you use the alternative protruding head rivets. Refer to SRM 51-10-01, 51-40-02, and 51-40-08.
6. Disassemble the repair parts.
7. Remove the nicks, scratches, gouges, burrs and sharp edges from the repair parts and the bare surfaces of the initial parts.
8. Apply a chemical conversion coating to the repair parts and to the bare surfaces of the initial parts. Refer to SRM 51-20-01.
9. Apply one layer of BMS 10-11, Type I primer to the repair parts and to the bare surfaces of the initial parts. Refer to SOPM 20-41-02.
10. Apply one layer of BMS 10-11, Type II enamel to the repair parts and to the bare surfaces of the initial parts. Refer to SOPM 20-41-02.
11. Install the part 4 filler in the chemmilled pocket of the skin at the new shear tie location between stringers S-27L and S-28L. Install the part 4 filler with BMS 5-95 sealant between the mating surfaces.
12. Install the repair parts with BMS 5-95 sealant between the mating surfaces. Use sufficient sealant to give a bead along the edges of the repair parts. Refer to SRM 51-20-05.
13. Install the fasteners.
14. Make a fillet seal if there is sufficient sealant along the edges of the repair parts. If not, apply more sealant and make a fillet seal.
15. On the internal side of the skin, apply a chemical conversion coating to the bare surfaces of the fasteners. Refer to SRM 51-20-01.
16. On the internal side of the skin, apply one layer of BMS 10-11, Type I primer to the bare surfaces of the fasteners. Refer to SOPM 20-41-02.
17. On the internal side of the skin, apply one layer of BMS 10-11, Type II enamel to the fasteners. Refer to SOPM 20-41-02.
18. Apply a layer of BMS 3-23, corrosion inhibiting compound to the internal structure of the repair area. Refer to SRM 51-20-01.

NOTES

- THIS IS A CATEGORY A REPAIR FOR 757-200 AND 757-SF AIRPLANES. THE INSPECTIONS GIVEN IN THE MAINTENANCE PLANNING DATA (MPD) ARE SUFFICIENT TO MAINTAIN THE DAMAGE TOLERANCE OF THE INITIAL STRUCTURE WITH THIS REPAIR INSTALLED. REFER TO SRM 51-00-06 FOR REPAIR CATEGORIES AND DEFINITIONS.
- WHEN YOU USE THIS REPAIR REFER TO:
 - SRM 51-10-02 FOR INSPECTION AND REMOVAL OF DAMAGE
 - SRM 51-10-01 FOR AERODYNAMIC SMOOTHNESS
 - SRM 51-20-01 FOR PROTECTIVE TREATMENT OF METALLIC AND GRAPHITE MATERIALS
 - SRM 51-20-05 FOR REPAIR SEALING
 - SRM 51-30-01 FOR SHEET METAL MATERIALS
 - SRM 51-40 FOR FASTENER CODE, REMOVAL AND INSTALLATION, HOLE SIZES AND EDGE MARGINS
 - SRM 51-40-08 FOR COUNTERSINKING OF BACR15FV RIVETS
 - SOPM 20-20-02 FOR PENETRANT INSPECTION PROCEDURES

**Fuselage Skin Crease Repair at BS 600 Between Stringers 27L and 27R
Figure 201 (Sheet 1 of 6)**

**757-200
STRUCTURAL REPAIR MANUAL**

NOTES (CONTINUED)

- SOPM 20-41-02 FOR APPLICATION OF CHEMICAL AND SOLVENT RESISTANT FINISHES
- NDT PART 6, 51-00-01 FOR THE HIGH FREQUENCY EDDY CURRENT INSPECTION PROCEDURES.
- ADD THE NECESSARY SHIMS TO GET A MAXIMUM GAP OF 0.010 INCH BETWEEN THE SHEAR TIE AND THE SKIN.

A DO ONE OF THE STEPS THAT FOLLOW:

- USE THE PART NUMBER OF THE INITIAL SHEAR TIE BETWEEN S-27L AND S-28L **E**
- MAKE A SHEAR TIE EQUIVALENT TO THAT PART NUMBER. MAKE THE FLANGE, WHICH ATTACHES TO THE FRAME SHEAR TIE, THE SAME HEIGHT AS THE PART 2 AND PART 3 SHEAR TIES **F**

B DO ONE OF THE STEPS THAT FOLLOW:

- USE THE PART NUMBER OF THE INITIAL SHEAR TIE BETWEEN S-28L AND S-28R
- MAKE A SHEAR TIE EQUIVALENT TO THAT PART NUMBER. **F**

C DO ONE OF THE STEPS THAT FOLLOW:

- USE THE PART NUMBER OF THE INITIAL SHEAR TIE BETWEEN S-27R AND S-28R
- MAKE A SHEAR TIE EQUIVALENT TO THAT PART NUMBER. **F**

D AS AN ALTERNATIVE, YOU CAN USE EQUIVALENT "T" TYPE SHEAR TIES IF YOU FIRST REMOVE THE INITIAL SHEAR TIES.






E CUT THE FLANGE OF THE SHEAR TIE. MAKE THE FLANGE, WHICH ATTACHES TO THE FRAME SHEAR TIE, THE SAME HEIGHT AS THE PART 2 AND PART 3 SHEAR TIES.

F 0.050 BARE 7075-T6. REFER TO SRM 51-30-01 FOR THE MINIMUM BEND RADIUS.

REPAIR MATERIAL			
	PART	QTY	MATERIAL
1	SHEAR TIE	1	A D
2	SHEAR TIE	1	B D
3	SHEAR TIE	1	C D
4	FILLER	1	0.016 CLAD 2024-T3

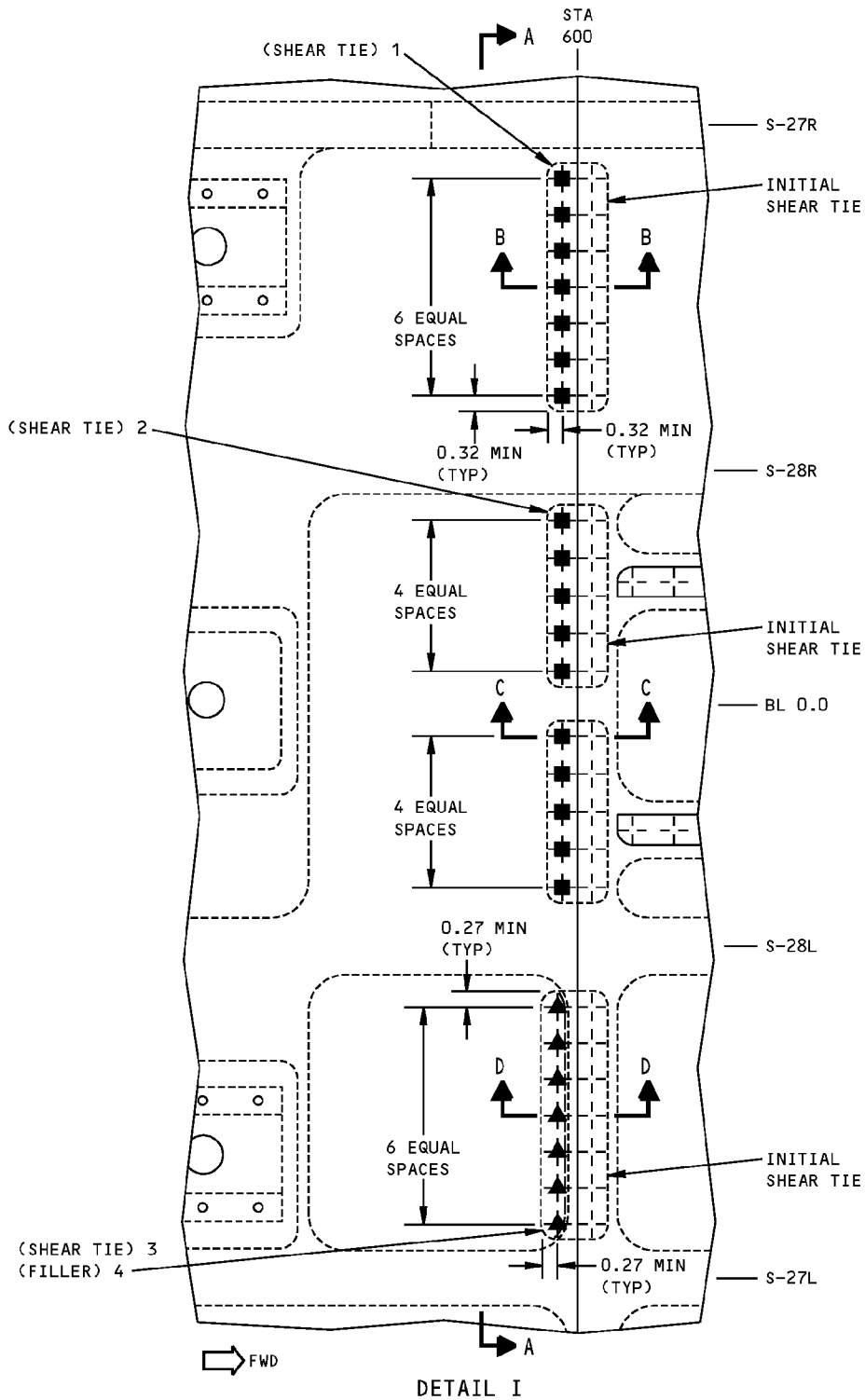
TABLE I

FASTENER SYMBOLS

-  REFERENCE FASTENER LOCATION.
-  REPAIR FASTENER LOCATION. INSTALL A BACR15FT6D RIVET. AN ALTERNATIVE IS A BACB30MY6K HEX DRIVE BOLT.
-  INITIAL FASTENER LOCATION. INSTALL A BACR15FT7D RIVET. AN ALTERNATIVE IS A 1/32 INCH OVERSIZE BACB30MY6K()Y HEX DRIVE BOLT.
-  REPAIR FASTENER LOCATION. INSTALL A BACR15FV5KE RIVET. DO NOT COUNTERSINK MORE THAN 70% OF THE SKIN THICKNESS. MICROSHAVE THE FASTENER HEAD. AN ALTERNATIVE IS A BACR15FT5KE RIVET.
-  REPAIR FASTENER LOCATION. INSTALL A BACR15FV6KE RIVET.

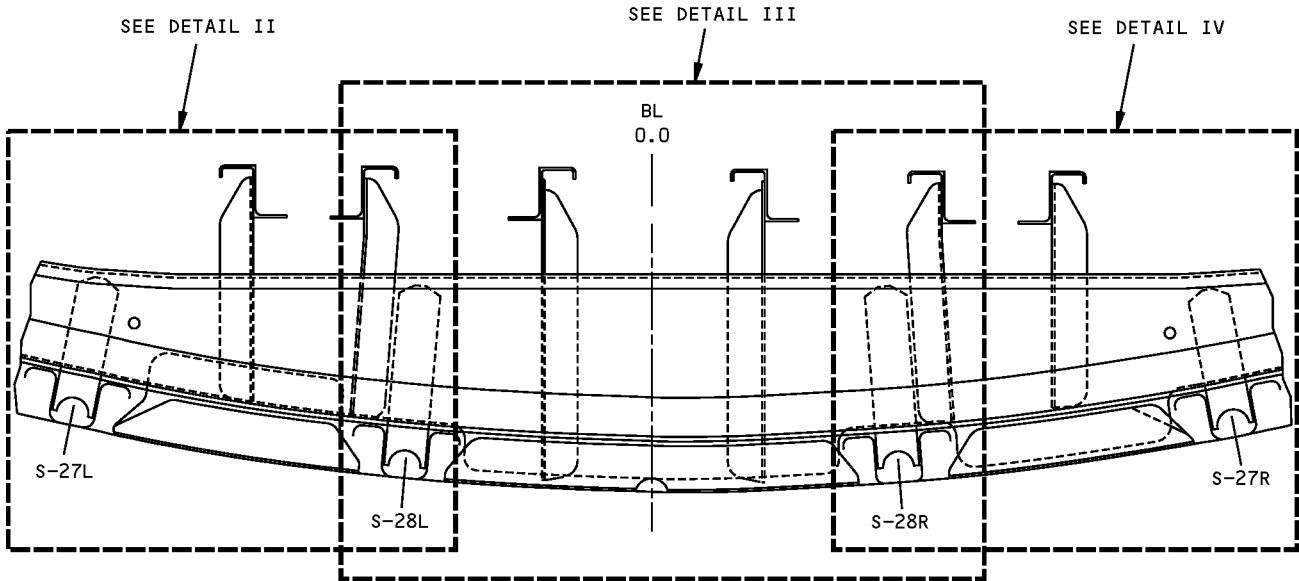
**Fuselage Skin Crease Repair at BS 600 Between Stringers 27L and 27R
Figure 201 (Sheet 2 of 6)**

**757-200
STRUCTURAL REPAIR MANUAL**

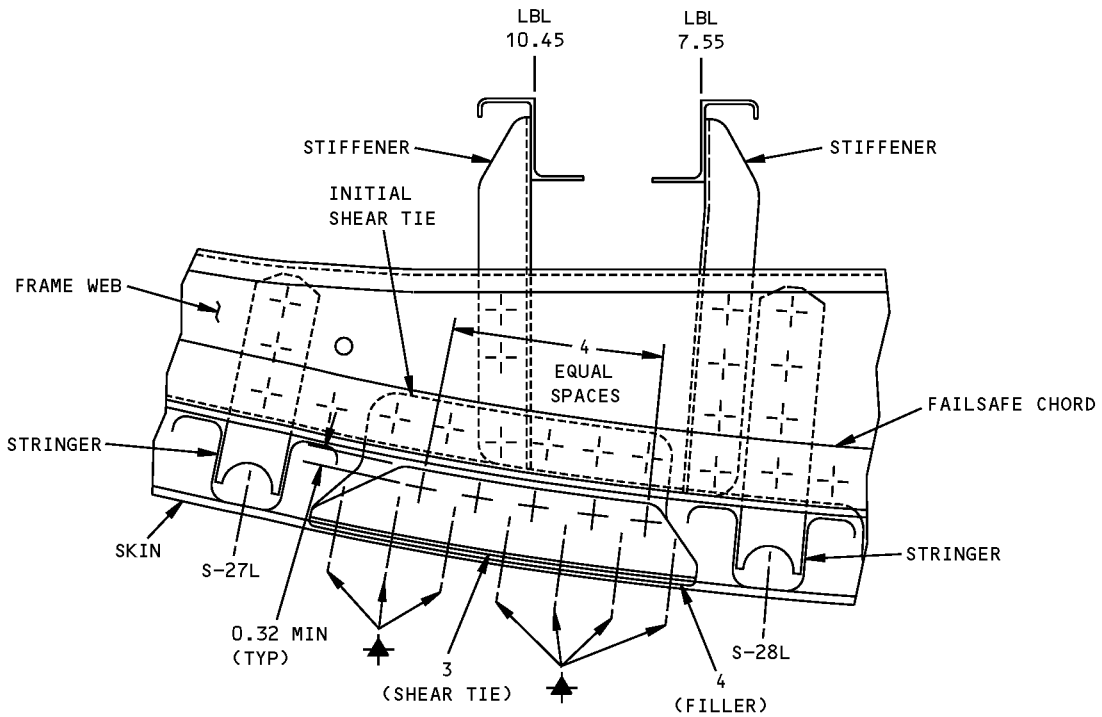


**Fuselage Skin Crease Repair at BS 600 Between Stringers 27L and 27R
Figure 201 (Sheet 3 of 6)**

**757-200
STRUCTURAL REPAIR MANUAL**



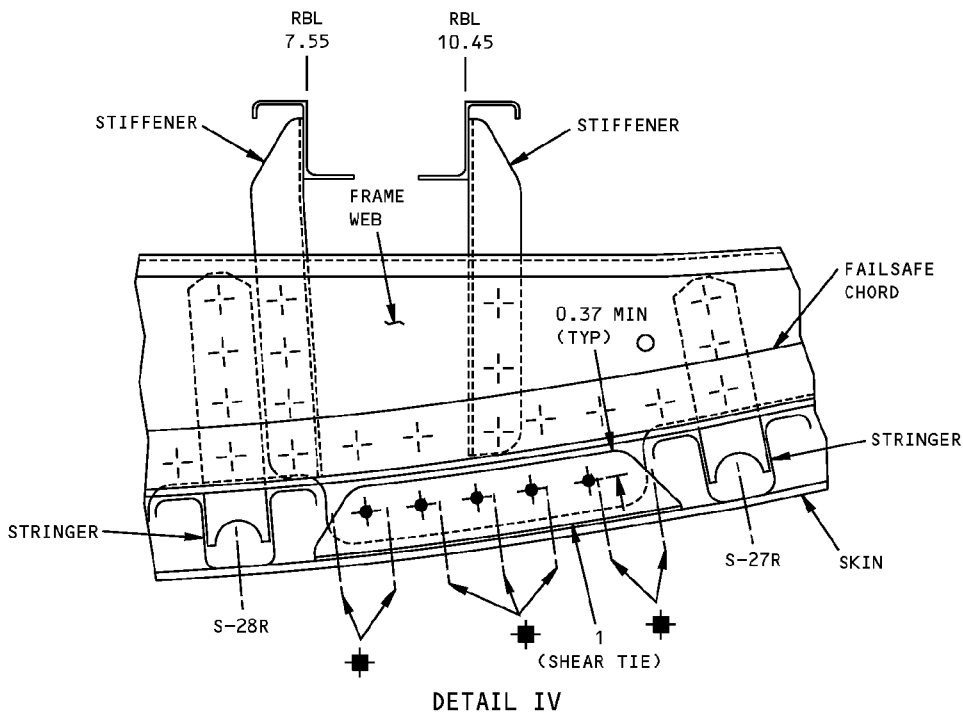
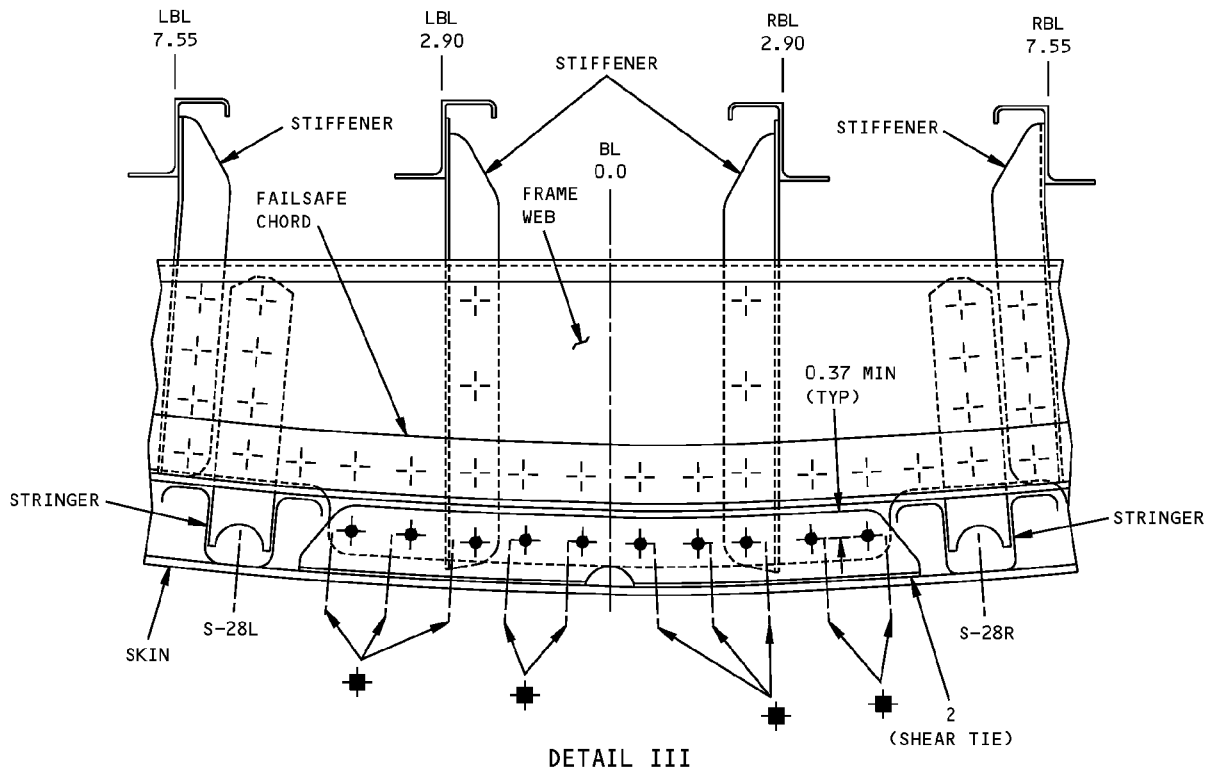
SECTION A-A



DETAIL II

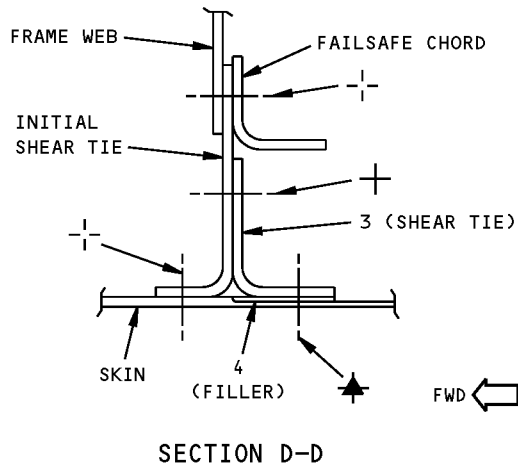
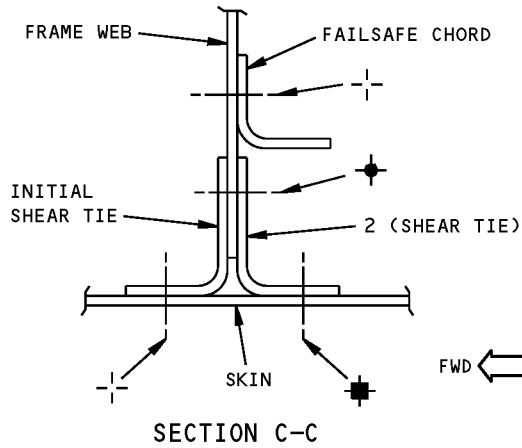
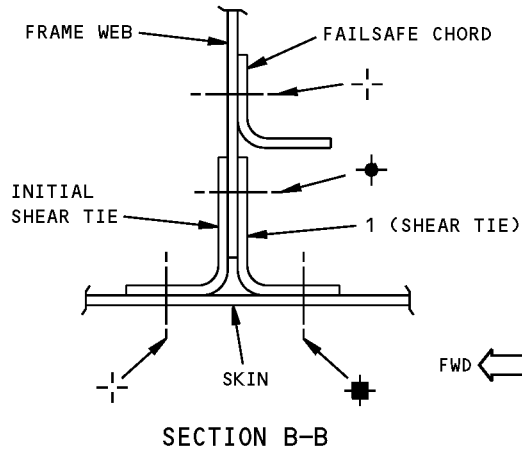
**Fuselage Skin Crease Repair at BS 600 Between Stringers 27L and 27R
Figure 201 (Sheet 4 of 6)**

**757-200
STRUCTURAL REPAIR MANUAL**



**Fuselage Skin Crease Repair at BS 600 Between Stringers 27L and 27R
Figure 201 (Sheet 5 of 6)**

**757-200
STRUCTURAL REPAIR MANUAL**



**Fuselage Skin Crease Repair at BS 600 Between Stringers 27L and 27R
Figure 201 (Sheet 6 of 6)**

STRUCTURAL REPAIR MANUAL**REPAIR 10 - FUSELAGE SKIN CREASE REPAIR AT BS 580 BETWEEN STRINGERS 27L AND 27R****REPAIR INSTRUCTIONS**

1. If necessary, remove the initial shear tie from the skin and the frame so that you can do step 2.
2. Carefully put the skin back to its correct contour.
3. When you make a repair at the part 2 shear tie, do the steps that follow:
 - A. Cut the forward end of each intercostal at LBL 2.90 and RBL 2.90, which are attached to the skin, between the first and second fastener locations. Make the cut a minimum of 1.7D from the second fastener. Do not damage the skin. See Detail I.
 - B. Cut the lower forward part of each intercostal to prevent interference with the part 2 shear tie.
4. Examine the damaged area to make sure that there are no cracks in the skin. Examine the shear ties and the frame for cracks. Use the eddy current inspection procedure. Refer to NDT Part 6, 51-00-01. If there is only external damage to the skin, a satisfactory alternative is the dye penetrant inspection procedure. Refer to SOPM 20-20-02.
5. Get the repair parts or make the equivalent repair parts. Put a radius on the edges of the part 4, part 5, and part 6 fillers where they will nest in the chem-milled steps. See Detail I and Table I.
6. Assemble the repair parts and drill the fastener holes. Backdrill through the initial fastener holes, if possible. Keep a minimum edge margin of 1.5D on all parts and a minimum edge margin of 1D on all chem-milled steps. Make sure the fastener heads are not in the radius of the chem-milled step or the shear tie. Countersink the fastener holes on the external side of the skin. Do not countersink more than 70% of the skin thickness. This will prevent knife-edging of the skin. Microshave the fastener head that is above the skin surface. Do not countersink the fastener holes if you use the alternative protruding head rivets. Refer to SRM 51-10-01, 51-40-02, and 51-40-08.
7. Disassemble the repair parts.
8. Remove the nicks, scratches, gouges, burrs and sharp edges from the repair parts and the bare surfaces of the initial parts.
9. Apply a chemical conversion coating to the repair parts and to the bare surfaces of the initial parts. Refer to SRM 51-20-01.
10. Apply one layer of BMS 10-11, Type I primer to the repair parts and to the bare surfaces of the initial parts. Refer to SOPM 20-41-02.
11. Apply one layer of BMS 10-11, Type II enamel to the repair parts and to the bare surfaces of the initial parts. Refer to SOPM 20-41-02.
12. Install the part 4 and part 5 fillers in the chem-milled pockets of the skin at the new shear tie location between stringers S-28L and S-28R. Install the part 6 filler in the chem-milled pocket of the skin at the new shear tie location between stringers S-27L and S-28L. Install all of the fillers with BMS 5-95 sealant between the mating surfaces.
13. Install the repair parts with BMS 5-95 sealant between the mating surfaces. Use sufficient sealant to give a bead along the edges of the repair parts. Refer to SRM 51-20-05.
14. Install the fasteners.
15. Make a fillet seal if there is sufficient sealant along the edges of the repair parts. If not, apply more sealant and make a fillet seal.
16. On the internal side of the skin, apply a chemical conversion coating to the bare surfaces of the fasteners. Refer to SRM 51-20-01.
17. On the internal side of the skin, apply one layer of BMS 10-11, Type I primer to the bare surfaces of the fasteners. Refer to SOPM 20-41-02.
18. On the internal side of the skin, apply one layer of BMS 10-11, Type II enamel to the fasteners. Refer to SOPM 20-41-02.
19. Apply a layer of BMS 3-23, corrosion inhibiting compound to the internal structure of the repair area. Refer to SRM 51-20-01.

**Fuselage Skin Crease Repair at BS 580 Between Stringers 27L and 27R
Figure 201 (Sheet 1 of 6)**

STRUCTURAL REPAIR MANUAL

NOTES

- THIS IS A CATEGORY A REPAIR FOR 757-200 AND 757-SF AIRPLANES. THE INSPECTIONS GIVEN IN THE MAINTENANCE PLANNING DATA (MPD) ARE SUFFICIENT TO MAINTAIN THE DAMAGE TOLERANCE OF THE INITIAL STRUCTURE WITH THIS REPAIR INSTALLED. REFER TO SRM 51-00-06 FOR REPAIR CATEGORIES AND DEFINITIONS.
- WHEN YOU USE THIS REPAIR REFER TO:
 - SRM 51-10-01 FOR AERODYNAMIC SMOOTHNESS
 - SRM 51-10-02 FOR INSPECTION AND REMOVAL OF DAMAGE
 - SRM 51-20-01 FOR PROTECTIVE TREATMENT OF METALLIC AND GRAPHITE MATERIALS
 - SRM 51-20-05 FOR REPAIR SEALING
 - SRM 51-30-01 FOR SHEET METAL MATERIALS
 - SRM 51-40 FOR FASTENER CODE, REMOVAL AND INSTALLATION, HOLE SIZES AND EDGE MARGINS
 - SRM 51-40-08 FOR COUNTERSINKING OF BACR15FV RIVETS
 - SOPM 20-20-02 FOR PENETRANT INSPECTION PROCEDURES
 - SOPM 20-41-02 FOR APPLICATION OF CHEMICAL AND SOLVENT RESISTANT FINISHES
 - NDT PART 6, 53-00-01 FOR THE HIGH FREQUENCY EDDY CURRENT INSPECTION PROCEDURES.
- ADD THE NECESSARY SHIMS TO GET A MAXIMUM GAP OF 0.010 INCH (0.25 mm) BETWEEN THE SHEAR TIE AND THE SKIN.

- A** DO ONE OF THE STEPS THAT FOLLOW:
- USE THE PART NUMBER OF THE INITIAL SHEAR TIE BETWEEN S-27L AND S-28L **D**
 - MAKE A SHEAR TIE EQUIVALENT TO THAT PART NUMBER. MAKE THE FLANGE, WHICH ATTACHES TO THE FRAME SHEAR TIE, THE SAME HEIGHT AS THE PART 2 AND PART 3 SHEAR TIES. **G**

- B** DO ONE OF THE STEPS THAT FOLLOW:
- USE THE PART NUMBER OF THE INITIAL SHEAR TIE BETWEEN S-27R AND S-28R
 - MAKE A SHEAR TIE EQUIVALENT TO THAT PART NUMBER. **G**

- C** AS AN ALTERNATIVE, YOU CAN USE EQUIVALENT "T" TYPE SHEAR TIES IF YOU FIRST REMOVE THE INITIAL SHEAR TIES.
- D** CUT THE FLANGE OF THE SHEAR TIE. MAKE THE FLANGE, WHICH ATTACHES TO THE INITIAL FRAME SHEAR TIE, THE SAME HEIGHT AS THE PART 2 AND PART 3 SHEAR TIES.
- E** DO NOT COUNTERSINK MORE THAN 70% OF THE SKIN THICKNESS. MICROSHAVE THE FASTENER HEAD THAT IS ABOVE THE SKIN SURFACE. REFER TO SRM 51-10-01, 51-40-02 AND 51-40-08.
- F** MAKE A SHEAR TIE EQUIVALENT TO THE INITIAL SHEAR TIE BETWEEN S-28R AND S-28L, BUT MAKE THE FLANGE WHICH IS ATTACHED TO THE SKIN LARGER.
- G** 0.050 BARE 7075-T6. REFER TO SRM 51-30-01 FOR THE MINIMUM BEND RADIUS.

FASTENER SYMBOLS

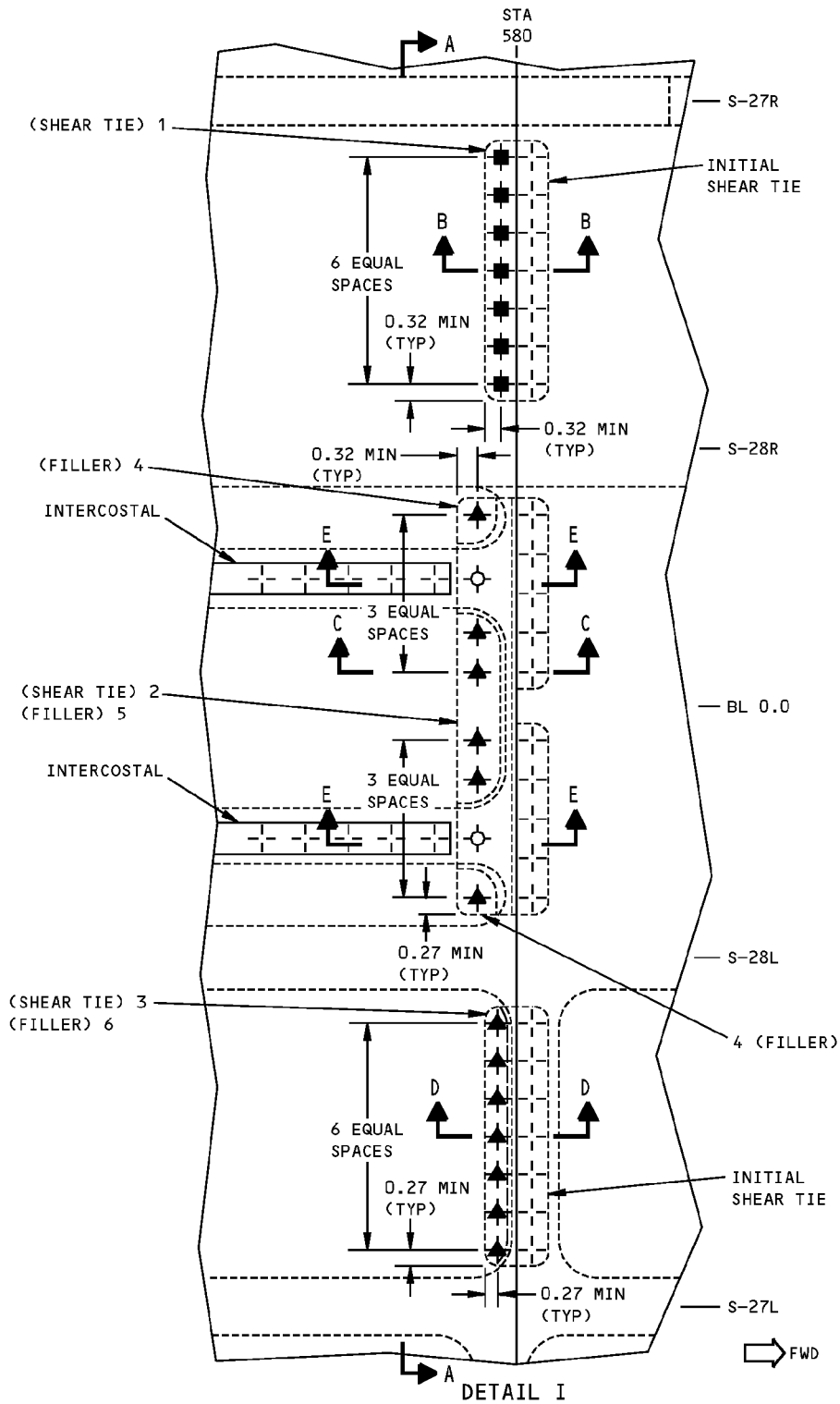
- ⊙ REFERENCE FASTENER LOCATION.
- ⊕ REPAIR FASTENER LOCATION. INSTALL A BACR15FT6D RIVET. AN ALTERNATIVE IS A BACB30MY6K HEX DRIVE BOLT.
- ⊕ INITIAL FASTENER LOCATION. INSTALL A BACR15FT7D RIVET. AN ALTERNATIVE IS A 1/32 INCH OVERSIZE BACB30MY6K(Y) HEX DRIVE BOLT.
- ⊕ INITIAL FASTENER LOCATION. INSTALL A BACR15FV6KE RIVET. **E**
- ⊕ REPAIR FASTENER LOCATION. INSTALL A BACR15FV5KE RIVET. **E** AN ALTERNATIVE IS A BACR15FT5KE RIVET.
- ⊕ REPAIR FASTENER LOCATION. INSTALL A BACR15FV6KE RIVET.

REPAIR MATERIAL			
	PART	QTY	MATERIAL
1	SHEAR TIE	1	A C
2	SHEAR TIE	1	0.050 BARE 7075-T6 F C
3	SHEAR TIE	1	B C
4	FILLER	2	0.016 CLAD 2024-T3
5	FILLER	1	0.016 CLAD 2024-T3
6	FILLER	1	0.016 CLAD 2024-T3

TABLE I

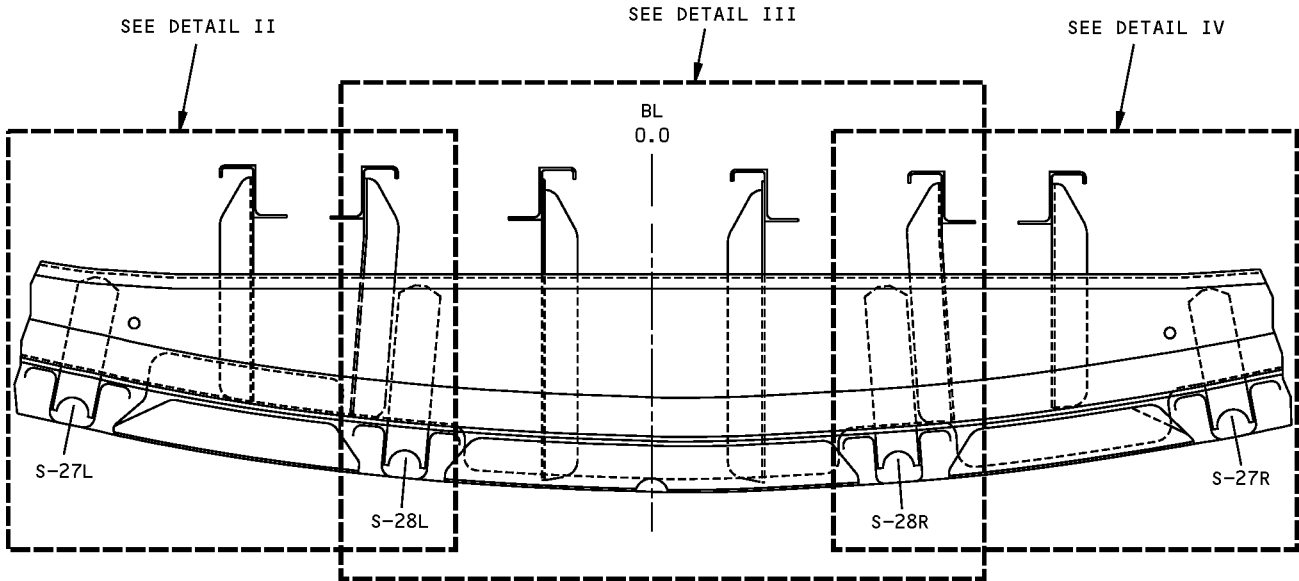
**Fuselage Skin Crease Repair at BS 580 Beteen Stringers 27L and 27R
Figure 201 (Sheet 2 of 6)**

**757-200
STRUCTURAL REPAIR MANUAL**

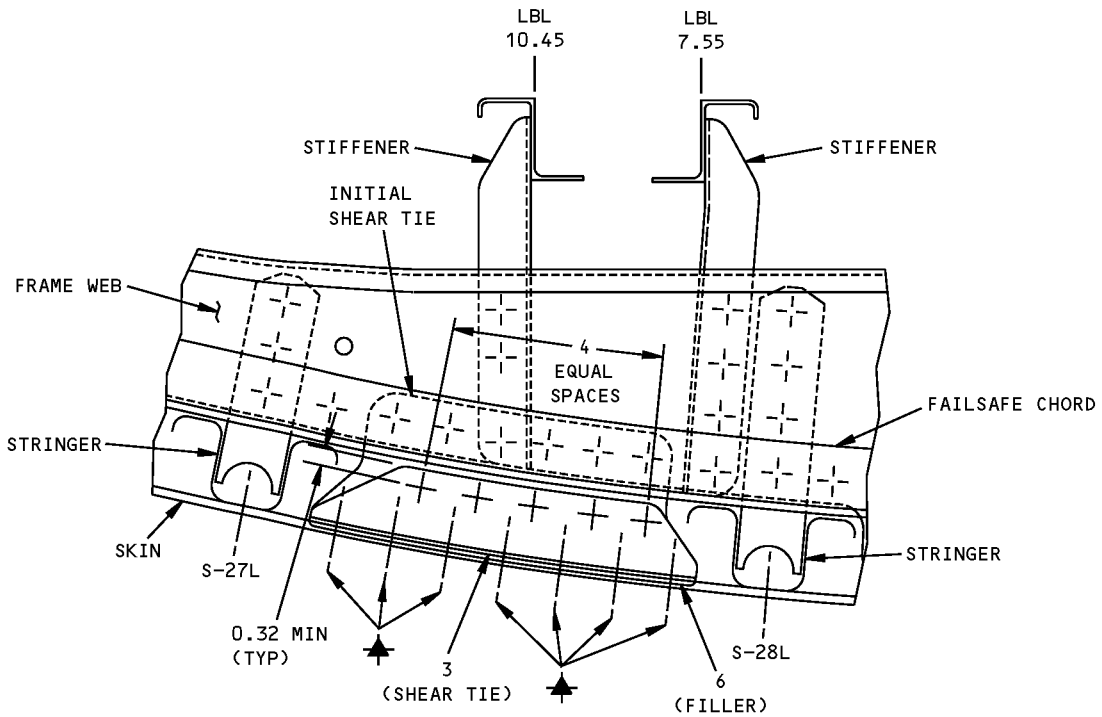


**Fuselage Skin Crease Repair at BS 580 Between Stringers 27L and 27R
Figure 201 (Sheet 3 of 6)**

**757-200
STRUCTURAL REPAIR MANUAL**



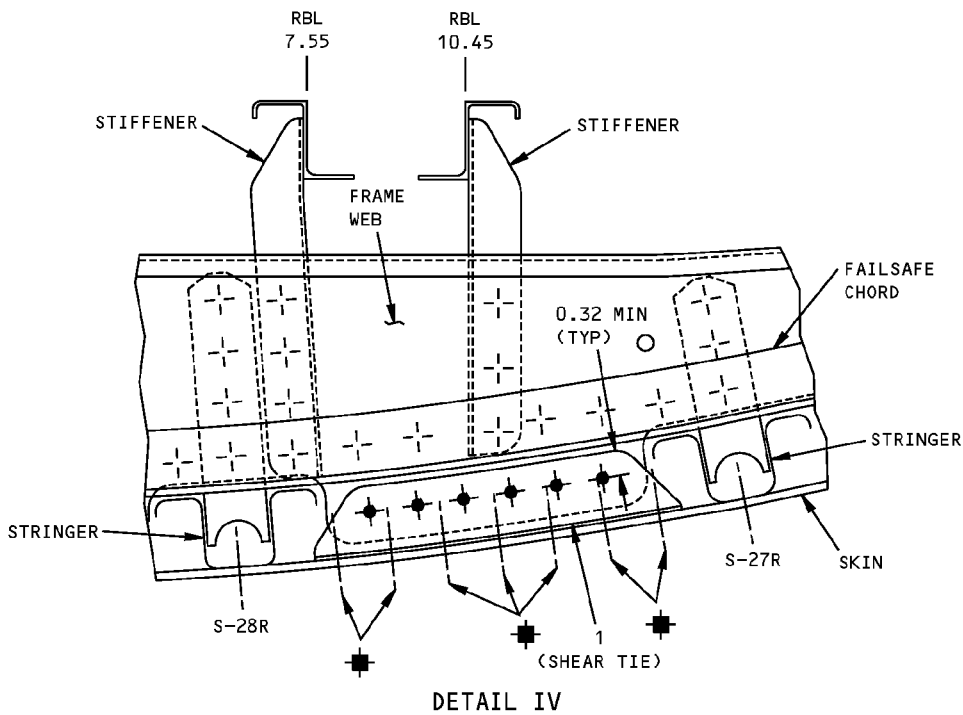
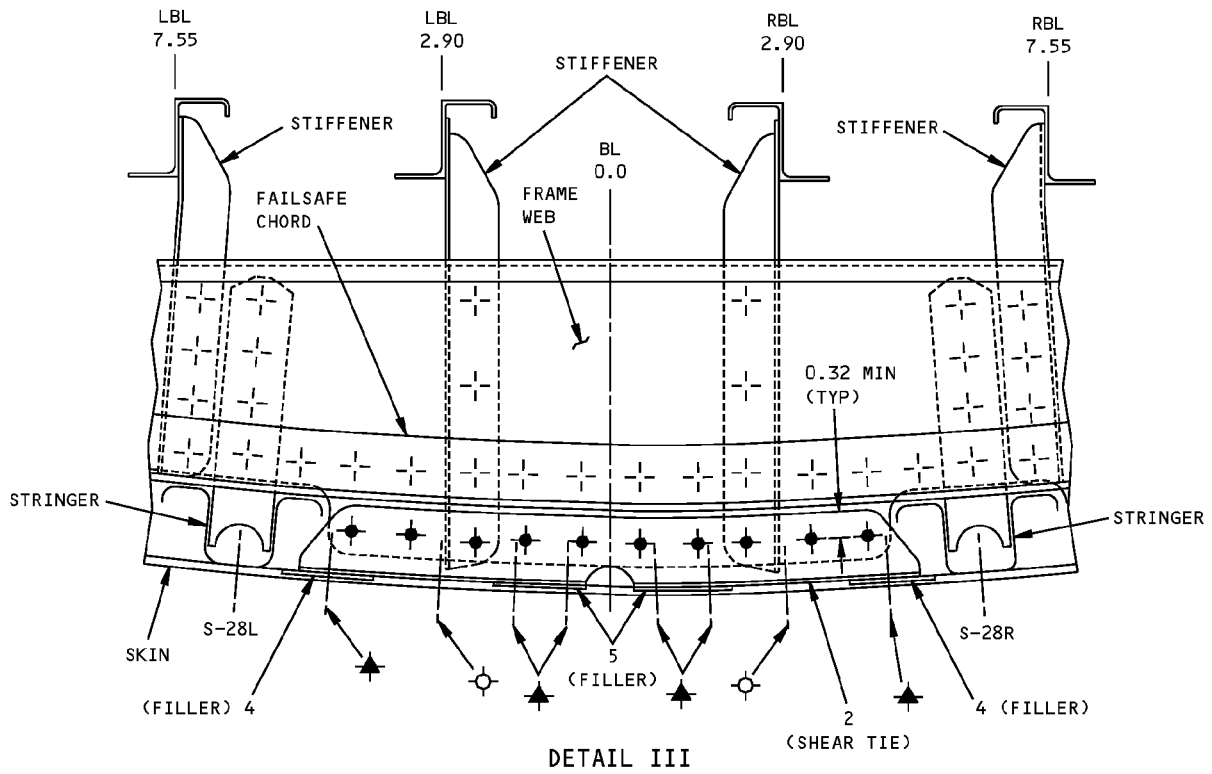
SECTION A-A



DETAIL II

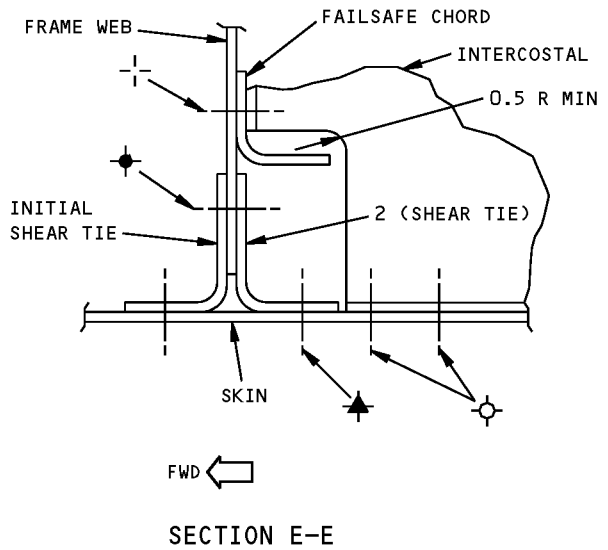
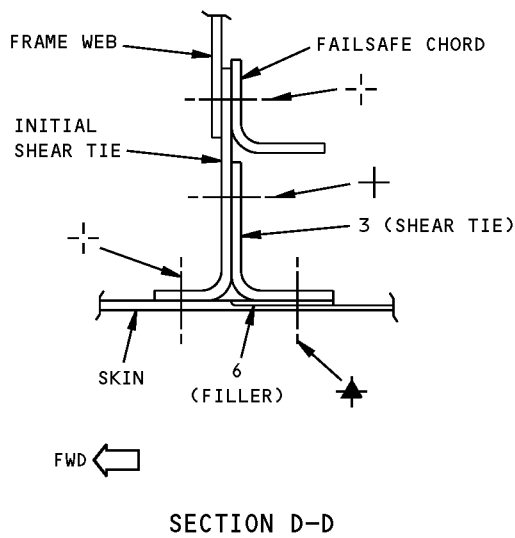
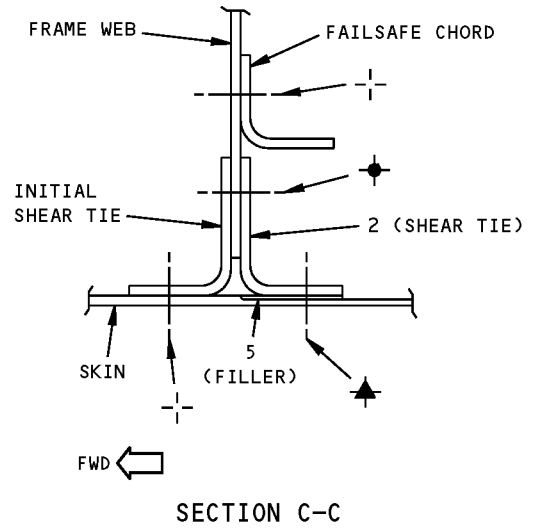
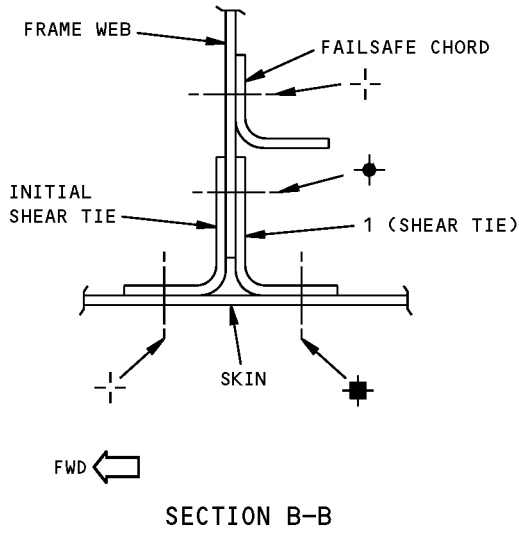
**Fuselage Skin Crease Repair at BS 580 Between Stringers 27L and 27R
Figure 201 (Sheet 4 of 6)**

**757-200
STRUCTURAL REPAIR MANUAL**



**Fuselage Skin Crease Repair at BS 580 Beteen Stringers 27L and 27R
Figure 201 (Sheet 5 of 6)**

**757-200
STRUCTURAL REPAIR MANUAL**



**Fuselage Skin Crease Repair at BS 580 Between Stringers 27L and 27R
Figure 201 (Sheet 6 of 6)**

STRUCTURAL REPAIR MANUAL**REPAIR 11 - FUSELAGE SKIN CREASE REPAIR AT BS 1420 BETWEEN STRINGERS 28L AND 28R****REPAIR INSTRUCTIONS**

1. If necessary, remove the initial shear tie from the skin and the frame so that you can do step 2.
2. Carefully put the skin back to its correct contour.
3. When you make a repair at the part 1 or part 4 shear ties, do the steps that follow:
 - A. Cut the forward end of each intercostal at LBL 10.45 and RBL 10.45, which is attached to the skin, between the first and second fastener locations. Make the cut a minimum of 1.7D from the second fastener. Do not damage the skin. See Detail I.
 - B. Cut the lower forward part of each intercostal to prevent interference with the part 1 and part 4 shear ties.
4. Examine the damaged area to make sure that there are no cracks in the skin. Examine the shear ties and the frame for cracks. Use the eddy current inspection procedure. Refer to NDT Part 6, 51-00-01. If there is only external damage to the skin, a satisfactory alternative is the dye penetrant inspection procedure. Refer to SOPM 20-20-02.
5. Get the repair parts or make the equivalent repair parts. See Detail I and Table I.
6. Assemble the repair parts and drill the fastener holes. Backdrill through the initial fastener holes, if possible. Keep a minimum edge margin of 1.5D on all parts and a minimum edge margin of 1D on all chem-milled steps. Countersink the fastener holes on the external side of the skin. Do not countersink more than 70% of the skin thickness. This will prevent knife-edging of the skin. Microshave the fastener head that is above the skin surface. Refer to SRM 51-10-01, 51-40-02, and 51-40-08.
7. Disassemble the repair parts.
8. Remove the nicks, scratches, gouges, burrs and sharp edges from the repair parts and the bare surfaces of the initial parts.
9. Apply a chemical conversion coating to the repair parts and to the bare surfaces of the initial parts. Refer to SRM 51-20-01.
10. Apply one layer of BMS 10-11, Type I primer to the repair parts and to the bare surfaces of the initial parts. Refer to SOPM 20-41-02.
11. Apply one layer of BMS 10-11, Type II enamel to the repair parts and to the bare surfaces of the initial parts. Refer to SOPM 20-41-02.
12. Install the part 5 filler in the chem-milled pocket at the part 1 shear tie location between stringers S-28L and S-29L. Install the part 6 filler in the chem-milled pocket at the part 2 shear tie location between stringers S-29L and S-30. Install the fillers with BMS 5-95 sealant between the mating surfaces.
13. Install the repair parts with BMS 5-95 sealant between the mating surfaces. Use sufficient sealant to give a bead along the edges of the repair parts. Refer to SRM 51-20-05.
14. Install the fasteners.
15. Make a fillet seal if there is sufficient sealant along the edges of the repair parts. If not, apply more sealant and make a fillet seal.
16. On the internal side of the skin, apply a chemical conversion coating to the bare surfaces of the fasteners. Refer to SRM 51-20-01.
17. On the internal side of the skin, apply one layer of BMS 10-11, Type I primer to the bare surfaces of the fasteners. Refer to SOPM 20-41-02.
18. On the internal side of the skin, apply one layer of BMS 10-11, Type II enamel to the fasteners. Refer to SOPM 20-41-02.
19. Apply a layer of BMS 3-23, corrosion inhibiting compound to the internal structure of the repair area. Refer to SRM 51-20-01.

NOTES

- THIS IS A CATEGORY A REPAIR FOR 757-200 AND 757-SF AIRPLANES. THE INSPECTIONS GIVEN IN THE MAINTENANCE PLANNING DATA (MPD) ARE SUFFICIENT TO MAINTAIN THE DAMAGE TOLERANCE OF THE INITIAL STRUCTURE WITH THIS REPAIR INSTALLED. REFER TO SRM 51-00-06 FOR REPAIR CATEGORIES AND DEFINITIONS.
- WHEN YOU USE THIS REPAIR REFER TO:
 - SRM 51-10-01 FOR AERODYNAMIC SMOOTHNESS
 - SRM 51-10-02 FOR INSPECTION AND REMOVAL OF DAMAGE
 - SRM 51-20-01 FOR PROTECTIVE TREATMENT OF METALLIC AND GRAPHITE MATERIALS
 - SRM 51-20-05 FOR REPAIR SEALING
 - SRM 51-30-01 FOR SHEET METAL MATERIALS
 - SRM 51-40 FOR FASTENER CODE, REMOVAL AND INSTALLATION, HOLE SIZES AND EDGE MARGINS
 - SRM 51-40-08 FOR COUNTERSINKING OF BACR15FV RIVETS

**Fuselage Skin Crease Repair at BS 1420 Between Stringers 28L and 28R
Figure 201 (Sheet 1 of 6)**

**757-200
STRUCTURAL REPAIR MANUAL**

NOTES (CONTINUED)





- SOPM 20-20-02 FOR EDDY CURRENT INSPECTION PROCEDURES
- SOPM 20-41-02 FOR APPLICATION OF CHEMICAL AND SOLVENT RESISTANT FINISHES
- NDT PART 6, 51-00-01 OR 51-00-19 FOR THE HIGH FREQUENCY EDDY CURRENT INSPECTION PROCEDURES.
- ADD THE NECESSARY SHIMS TO GET A MAXIMUM GAP OF 0.010 INCH BETWEEN THE SHEAR TIE AND THE SKIN.

- A** DO ONE OF THE STEPS THAT FOLLOW:
 - USE THE PART NUMBER OF THE INITIAL SHEAR TIE BETWEEN S-28R AND S-29R
 - MAKE A SHEAR TIE EQUIVALENT TO THAT PART NUMBER. **D**
- B** AS AN ALTERNATIVE, YOU CAN USE THE EQUIVALENT "T" TYPE SHEAR TIES IF YOU FIRST REMOVE THE INITIAL SHEAR TIES.
- C** MAKE A SHEAR TIE EQUIVALENT TO THE INITIAL SHEAR TIE ON THE FORWARD SIDE OF THE FRAME AT BS 1420.
- D** 0.050 BARE 7075-T6. REFER TO SRM 51-30-01 FOR THE MINIMUM BEND RADIUS.

REPAIR MATERIAL			
	PART	QTY	MATERIAL
1	SHEAR TIE	1	A B
2	SHEAR TIE	1	0.050 BARE 7075-T6 B C
3	SHEAR TIE	1	0.050 BARE 7075-T6 B C
4	SHEAR TIE	1	0.050 BARE 7075-T6 B C
5	FILLER	1	0.005 CLAD 2024-T3
6	FILLER	1	0.005 CLAD 2024-T3

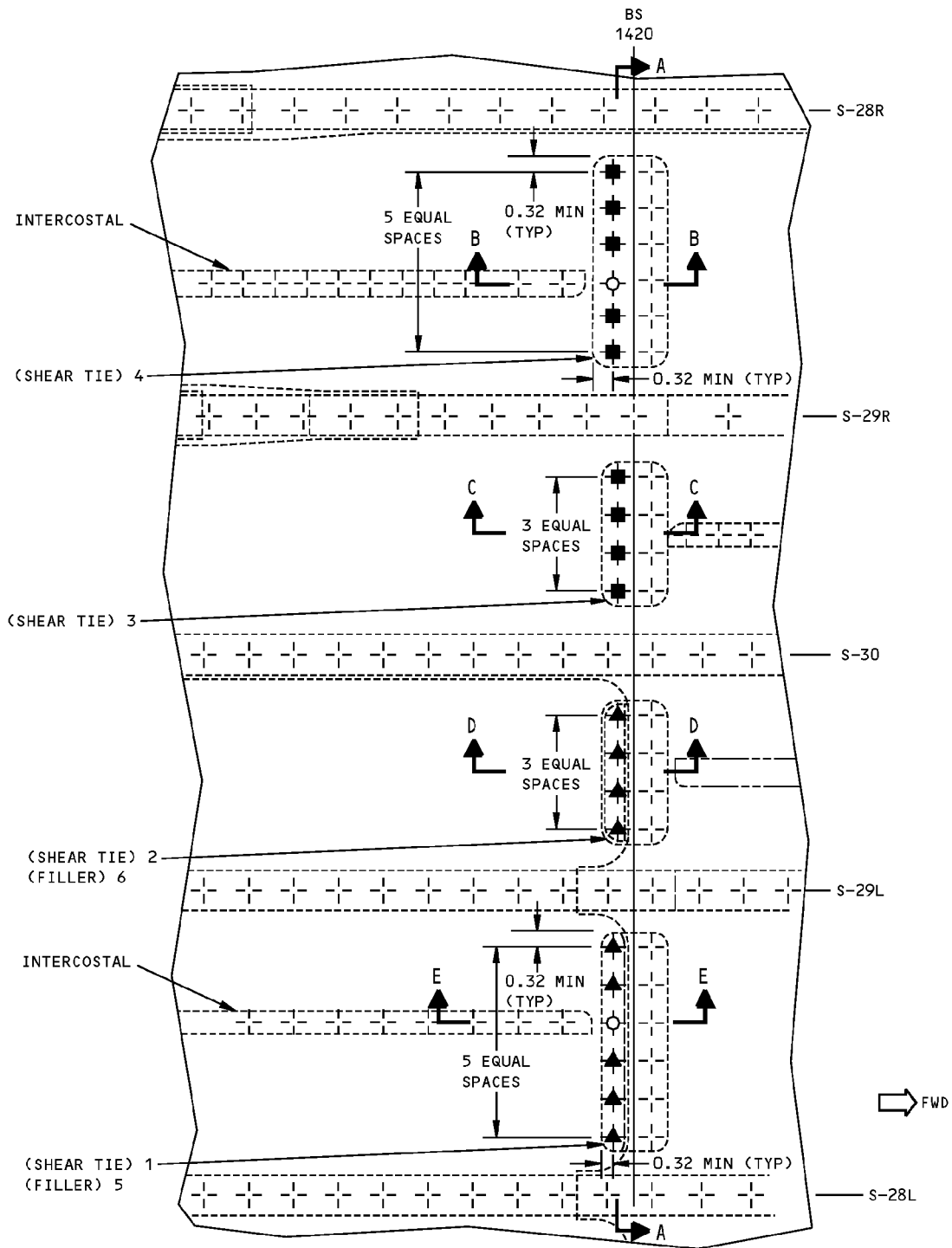
TABLE I

FASTENER SYMBOLS

-  REFERENCE FASTENER LOCATION.
-  INITIAL FASTENER LOCATION. INSTALL A BACR15FT7D RIVET. AN ALTERNATIVE IS A 1/32 INCH OVERSIZE BACB30MY6K()Y HEX DRIVE BOLT.
-  INITIAL FASTENER LOCATION. INSTALL A BACR15FV6KE RIVET.
-  REPAIR FASTENER LOCATION. INSTALL A BACR15FV6KE RIVET.

**Fuselage Skin Crease Repair at BS 1420 Between Stringers 28L and 28R
Figure 201 (Sheet 2 of 6)**

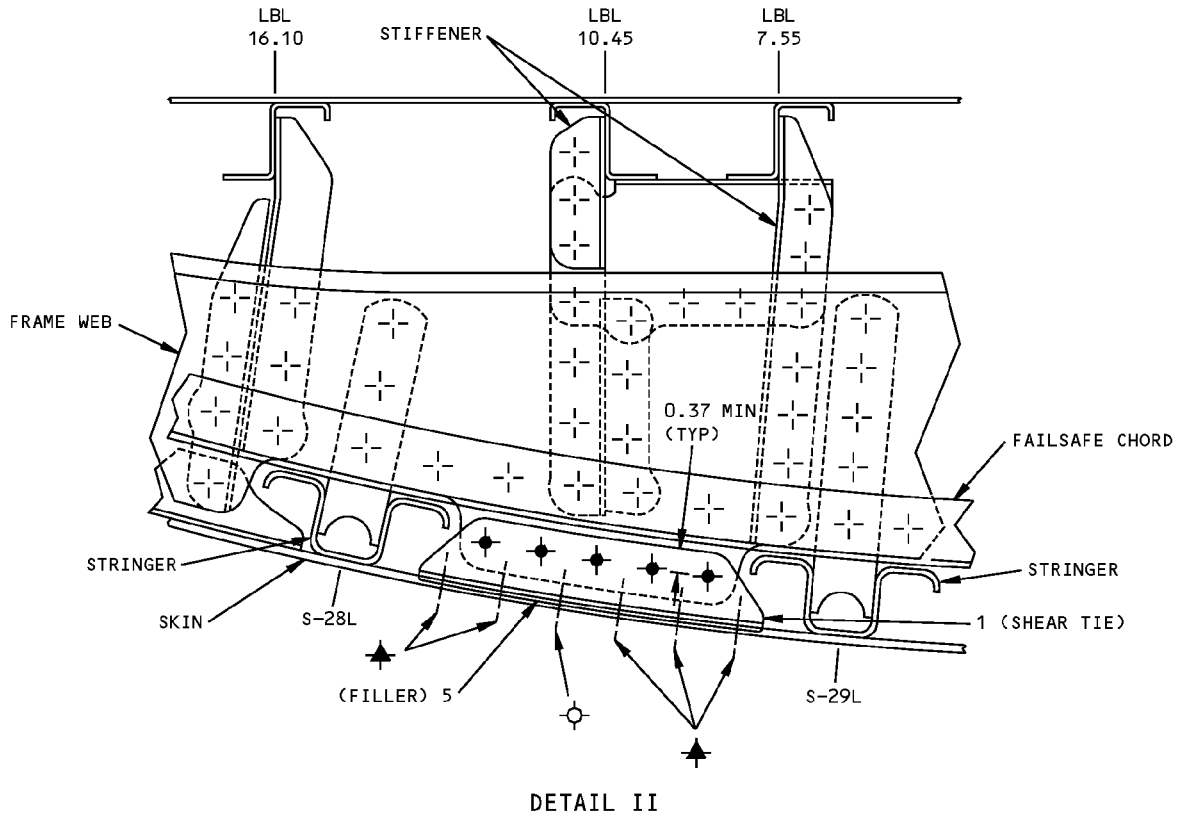
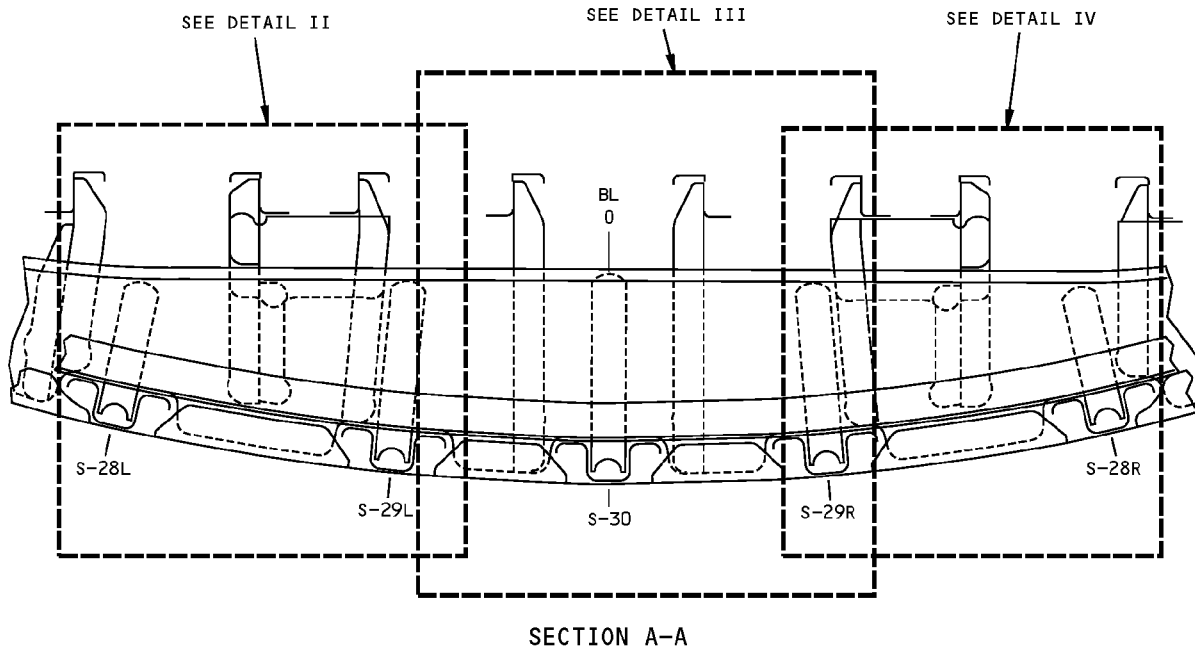
**757-200
STRUCTURAL REPAIR MANUAL**



DETAIL I

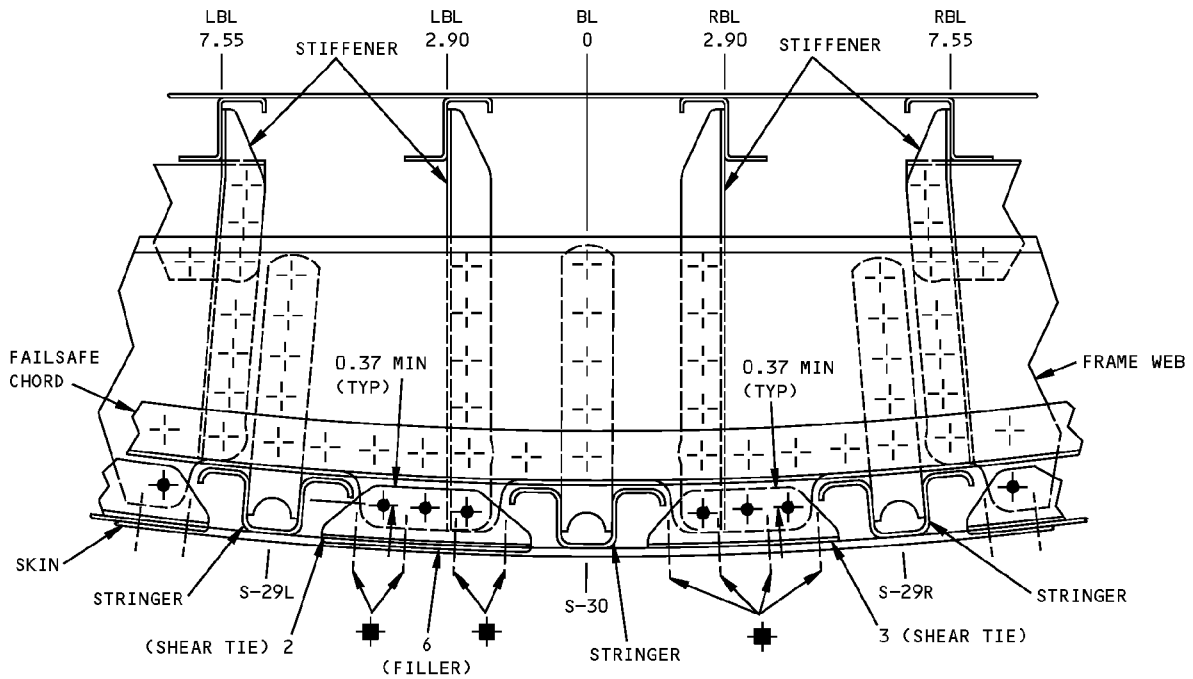
**Fuselage Skin Crease Repair at BS 1420 Between Stringers 28L and 28R
Figure 201 (Sheet 3 of 6)**

**757-200
STRUCTURAL REPAIR MANUAL**

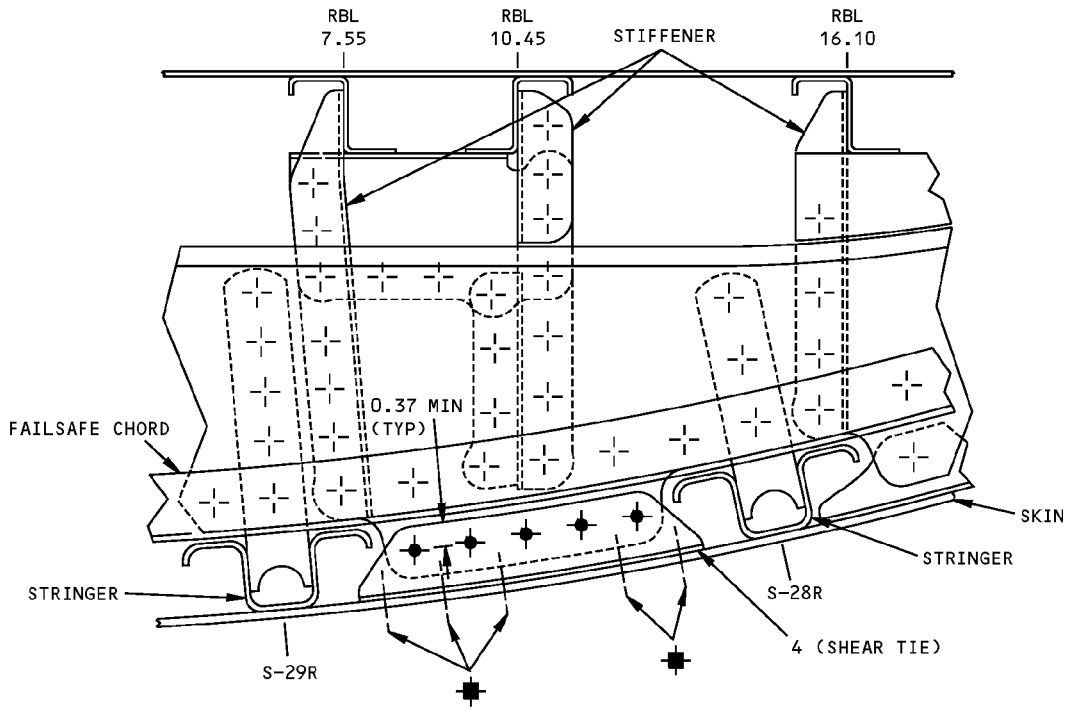


**Fuselage Skin Crease Repair at BS 1420 Between Stringers 28L and 28R
Figure 201 (Sheet 4 of 6)**

**757-200
STRUCTURAL REPAIR MANUAL**



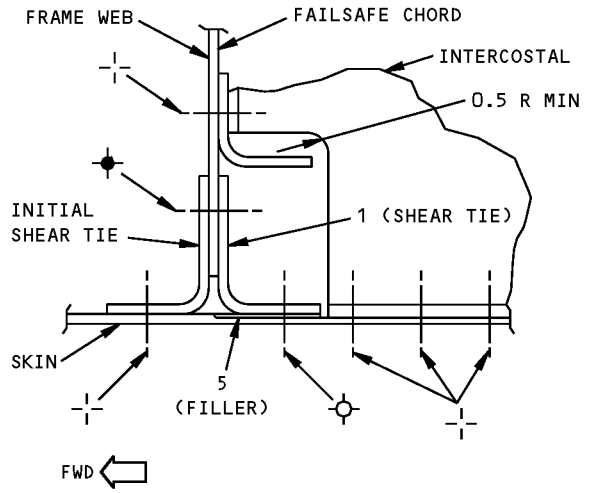
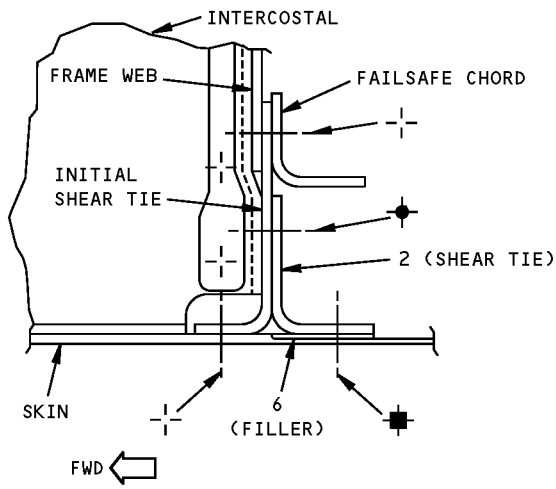
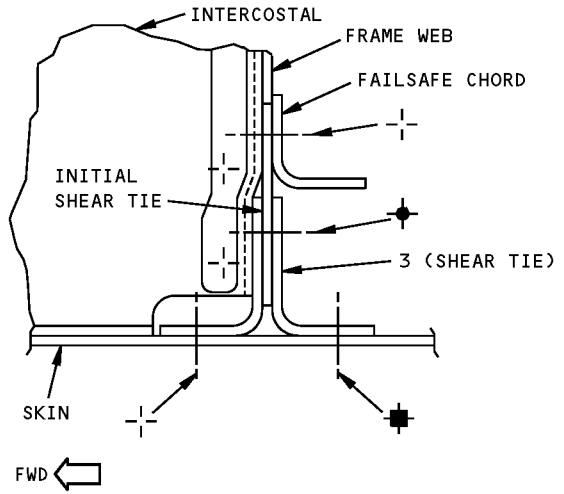
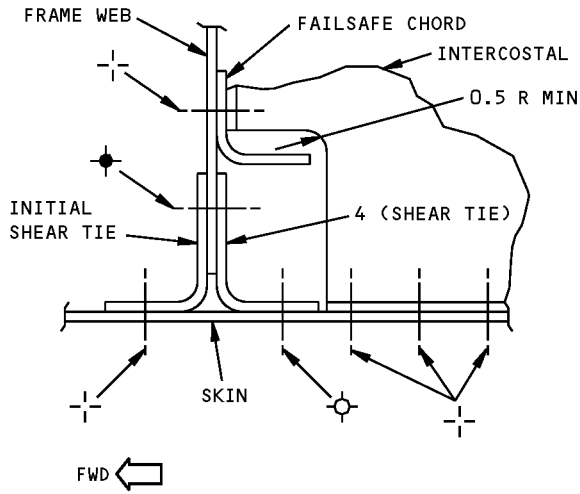
DETAIL III



DETAIL IV

**Fuselage Skin Crease Repair at BS 1420 Between Stringers 28L and 28R
Figure 201 (Sheet 5 of 6)**

**757-200
STRUCTURAL REPAIR MANUAL**



**Fuselage Skin Crease Repair at BS 1420 Between Stringers 28L and 28R
Figure 201 (Sheet 6 of 6)**

STRUCTURAL REPAIR MANUAL

REPAIR 12 - REPAIR OF SKIN TEAR STRAP DISBOND BETWEEN STRINGERS 10L AND 10R - SECTION 43 AND

46

APPLICABILITY
THIS REPAIR IS APPLICABLE TO A DISBOND AT A TEAR STRAP BETWEEN STRINGERS 10L AND 10R, IN THE SECTIONS 43 AND/OR 46.

REPAIR INSTRUCTIONS

1. Get access to the disbond area. Refer to Detail I.
2. Do a 10X visual inspection for corrosion. If you find corrosion do not use this repair.

NOTE: Bulges in the tear strap or skin, or a white powder residue, or a thin black line along the edges of the tear strap or fasteners are indications of corrosion.

3. Do an ultra low frequency eddy current examination for faying surface corrosion. Refer to the NDT Part 6, 51-00-02, or 55-00-10, or use an equivalent procedure. Tell Boeing about the quantity and location of the corrosion.
4. If you found no corrosion, the entire tear strap must be repaired. Remove all fasteners coded with the symbol \oplus in the appropriate Detail VII through XIII.
5. Do a high frequency eddy current (HFEC) inspection of the fastener holes in the skin and in the tear strap. Refer to NDT Part 6, 51-00-16, or use an equivalent procedure. If you find a crack do not use this repair. Tell Boeing about the number and location of the cracks.

CAUTION: USE HOLE CLAMPS TO KEEP THE SKIN AND TEAR STRAP TOGETHER. IF YOU DO NOT CLAMP THE TEAR STRAP TO THE SKIN WHILE YOU DRILL, MORE DISBONDING CAN OCCUR.

6. Temporarily attach the disbonded tearstrap to the skin.
CAUTION: DO NOT SCRIBE LINES ON THE SKIN OR TEAR STRAPS TO MARK THE LOCATION FOR FASTENER HOLES. SCRIBE LINES REDUCE THE FATIGUE LIFE OF THE STRUCTURE.
7. Drill the fastener holes from the internal side of the fuselage. This is to prevent the tear strap from being pushed away from the skin and to assure sufficient edge margins. See Details I through VI.
8. Remove the nicks, scratches, gouges, burrs, and sharp edges in the repair area.

9. Apply one layer of BMS 3-23, Type 2 corrosion inhibiting compound followed by a layer of BMS 3-26 corrosion inhibiting compound to the repair area. Make sure that the corrosion inhibiting compound goes into the disbond interface. If necessary, separate the strap from the skin with a wedge. Make the wedge from a material softer than aluminum. You can use plastic and phenolic materials for the wedge.

10. Install the fasteners.

NOTES

- THIS IS A CATEGORY A REPAIR FOR 757-SF AIRPLANES. THE INSPECTIONS GIVEN IN THE MAINTENANCE PLANNING DATA (MPD) ARE SUFFICIENT TO MAINTAIN THE DAMAGE TOLERANCE OF THE INITIAL STRUCTURE WITH THIS REPAIR INSTALLED. REFER TO SRM 51-00-06 FOR REPAIR CATEGORIES AND DEFINITIONS.
- REFER TO THE FOLLOWING WHEN USING THIS REPAIR:
 - SRM 51-20-01 FOR PROTECTIVE TREATMENT OF METAL
 - SRM 51-10-02 FOR INSPECTION AND REMOVAL OF DAMAGE
 - SRM 50-40 FOR FASTENER CODE, INSTALLATION AND REMOVAL, HOLE SIZES AND EDGE MARGINS
 - NDT PART 6, 51-00-02 - INSPECTION OF THE FAYING SURFACE OF THE OUTER ALUMINUM SKIN FOR CORROSION (METER DISPLAY)
 - NDT PART 6, 51-00-10 - ALUMINUM SKIN CORROSION LOSS INSPECTION (IMPEDANCE PLANE DISPLAY)
 - NDT PART 6, 51-00-16 - ALUMINUM PART FASTENER HOLE INSPECTION (ROTARY SCANNER)

- A** IF THE DISBOND IS BETWEEN STRINGERS S1 AND S3, OR BETWEEN STRINGERS S5 AND S9 USE THE REPAIR GIVEN IN DETAIL VII EXCEPT:
- A. USE DETAIL XI BETWEEN STRINGERS 6 AND 7 AT BS 760
 - B. USE DETAIL XII BETWEEN STRINGERS 7 AND 8 AT BS 760
- IF THE DISBOND IS BETWEEN STRINGERS S3 AND S4, USE THE REPAIR GIVEN IN DETAIL VIII
- IF THE DISBOND IS BETWEEN STRINGERS S4 AND S5, USE THE REPAIR GIVEN IN DETAIL IX.
- IF THE DISBOND IS BETWEEN STRINGERS S9 AND S10, USE THE REPAIR GIVEN IN DETAIL X, EXCEPT ON THE 4-DOOR MODEL AIRPLANE, USE THE REPAIR GIVEN IN DETAIL XIII AT BS 1380 AND BS1400.
- B** AN AIRPLANE CAN HAVE OVERWING EXITS OR 4-DOORS, BUT NOT THE TWO TOGETHER.

**Repair of Skin Tear Strap Disbond Between Stringers 10L and 10R - Section 43 and 46
Figure 201 (Sheet 1 of 7)**

STRUCTURAL REPAIR MANUAL

FASTENER SYMBOLS



INITIAL FASTENER LOCATION.

IF THE INITIAL FASTENER IS 6/32 DIAMETER SIZE, INSTALL A 120-DEGREE HEAD BACR15FV7KE() RIVET WITH A LIMITED COUNTER-SINK DEPTH 0.040 INCH TO 0.042 INCH ON THE SKIN. MICROSHAVE THE MANUFACTURED HEAD.

IF THE INITIAL FASTENER IS 8/32 DIAMETER SIZE, INSTALL A 120-DEGREE HEAD BACR15FV9KE() RIVET WITH A LIMITED COUNTER-SINK DEPTH 0.052 INCH TO 0.055 INCH ON THE SKIN. MICROSHAVE THE MANUFACTURED HEAD.



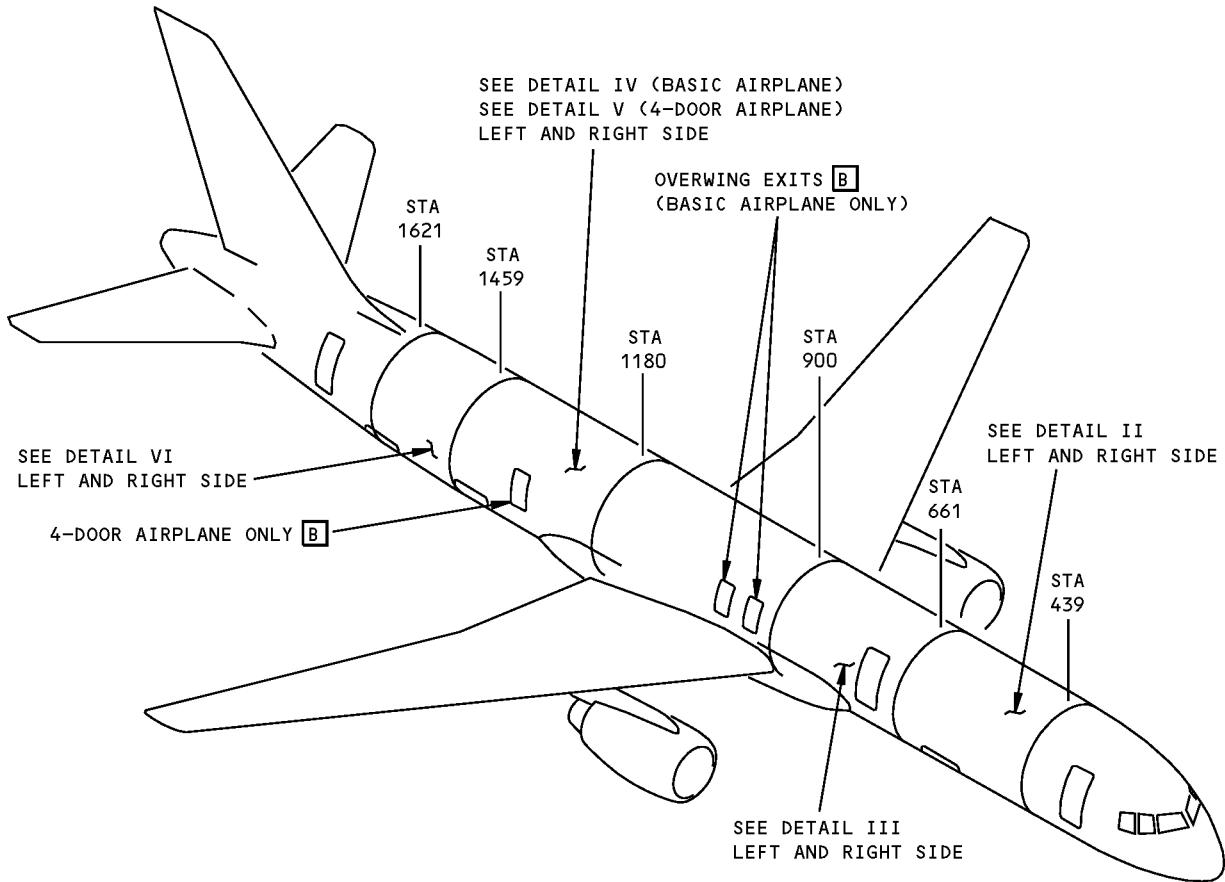
REPAIR FASTENER LOCATION. INSTALL THESE FASTENERS WITH THE MANUFACTURED HEAD ON THE OUTSIDE OF THE FUSELAGE. IF THE THICKNESS OF THE SKIN IS LESS THAN 0.063 INCH, INSTALL A BACR15BB6D, OR BACR15BB6DD, OR BACR15FT6DD RIVET. IF THE THICKNESS OF THE SKIN IS 0.063 INCH OR MORE, INSTALL A BACR15BB8D, OR BACR15BB8DD, OR BACR15FT8DD RIVET.



INITIAL FASTENER LOCATION. DO NOT REMOVE THESE FASTENERS.

Repair of Skin Tear Strap Disbond Between Stringers 10L and 10R - Section 43 and 46
Figure 201 (Sheet 2 of 7)

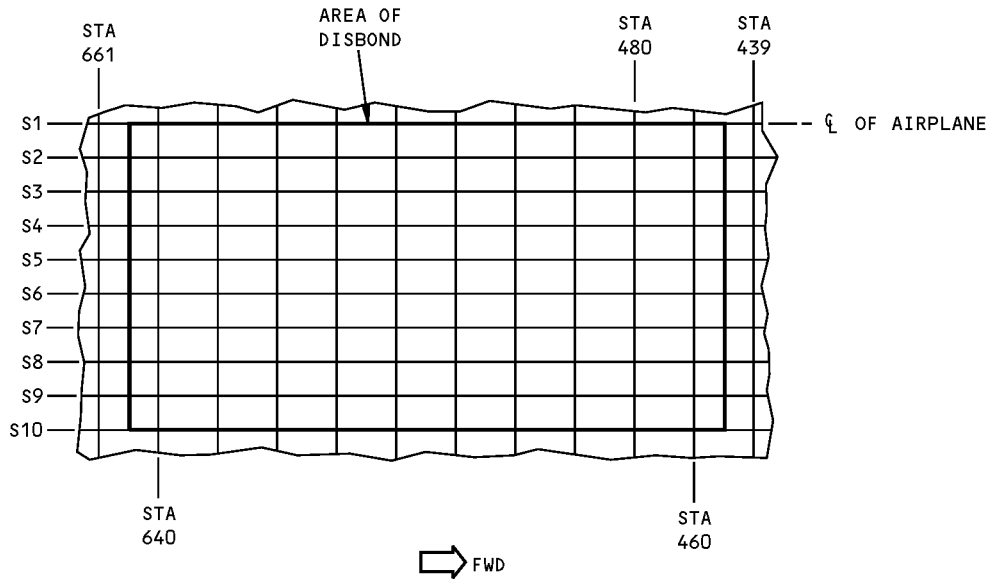
**757-200
STRUCTURAL REPAIR MANUAL**



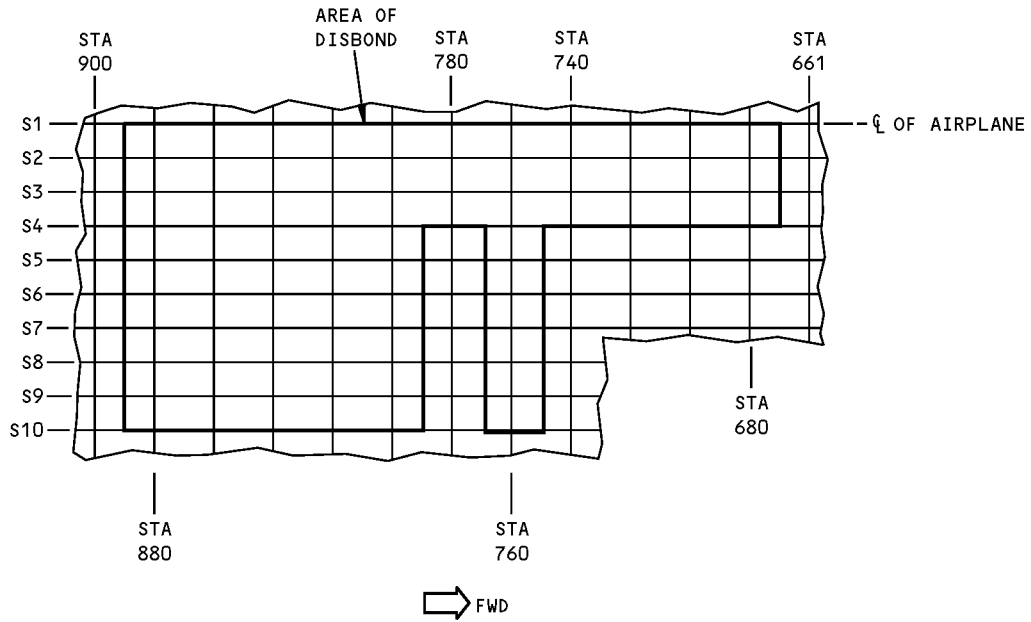
DETAIL I

**Repair of Skin Tear Strap Disbond Between Stringers 10L and 10R - Section 43 and 46
Figure 201 (Sheet 3 of 7)**

**757-200
STRUCTURAL REPAIR MANUAL**



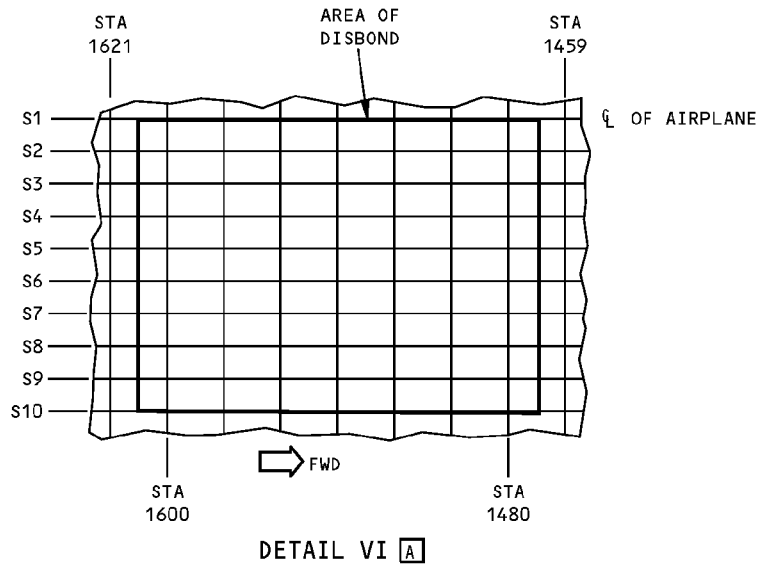
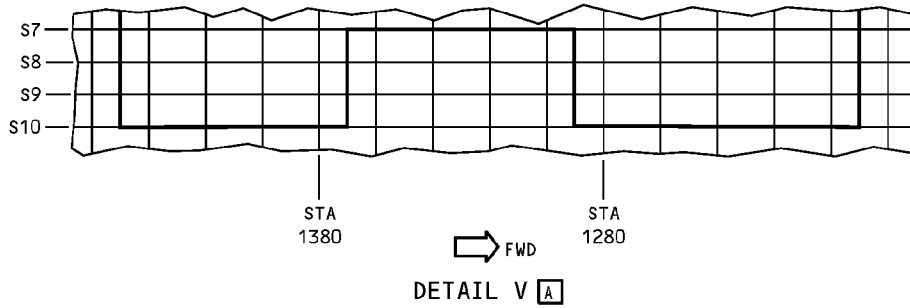
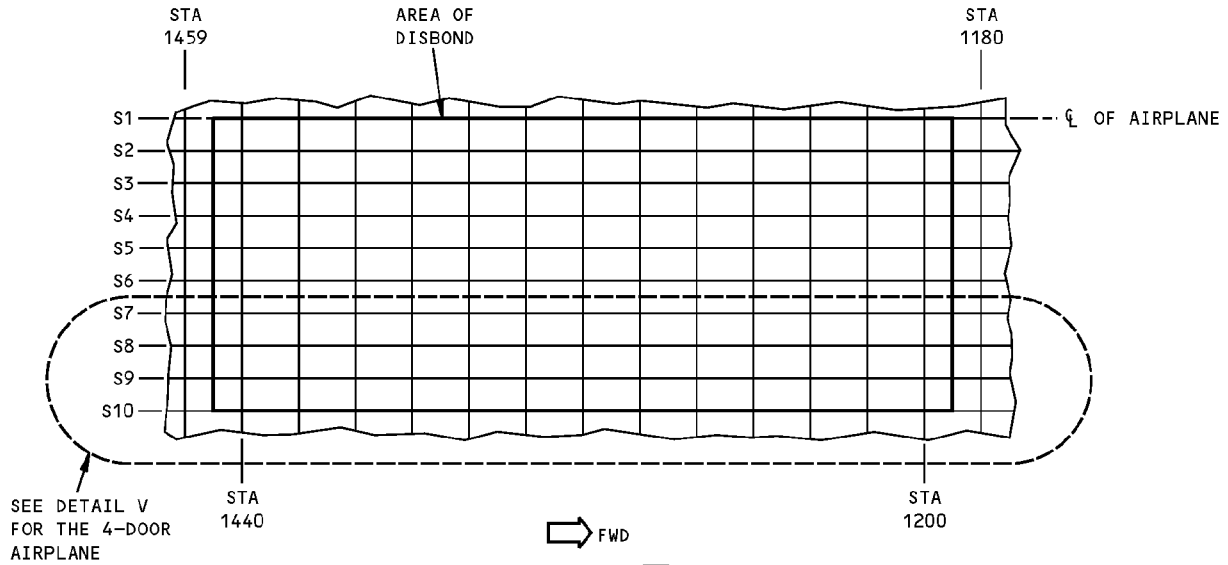
DETAIL II **A**



DETAIL III **A**

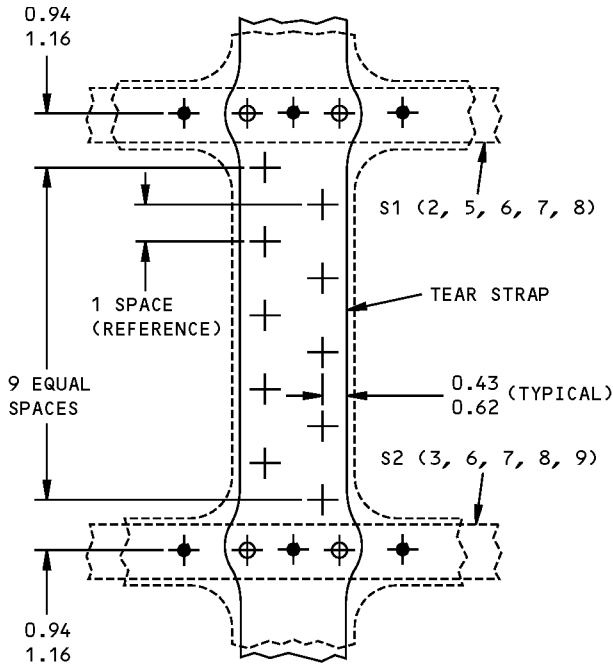
**Repair of Skin Tear Strap Disbond Between Stringers 10L and 10R - Section 43 and 46
Figure 201 (Sheet 4 of 7)**

**757-200
STRUCTURAL REPAIR MANUAL**

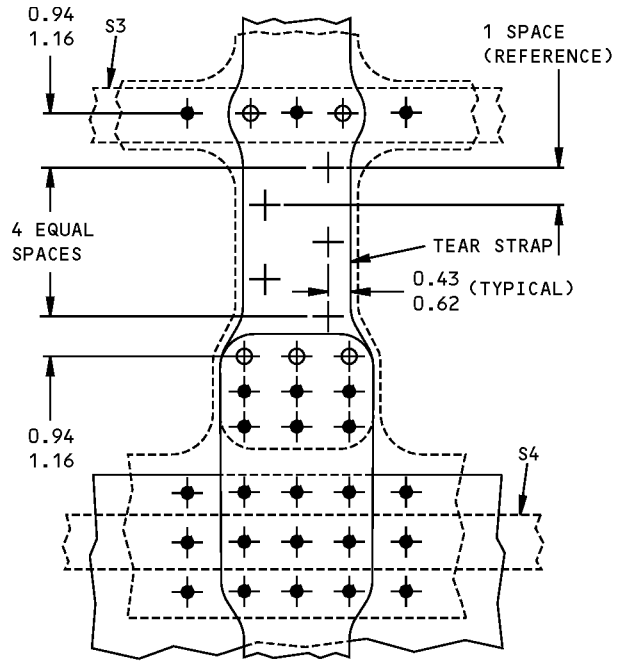


**Repair of Skin Tear Strap Disbond Between Stringers 10L and 10R - Section 43 and 46
Figure 201 (Sheet 5 of 7)**

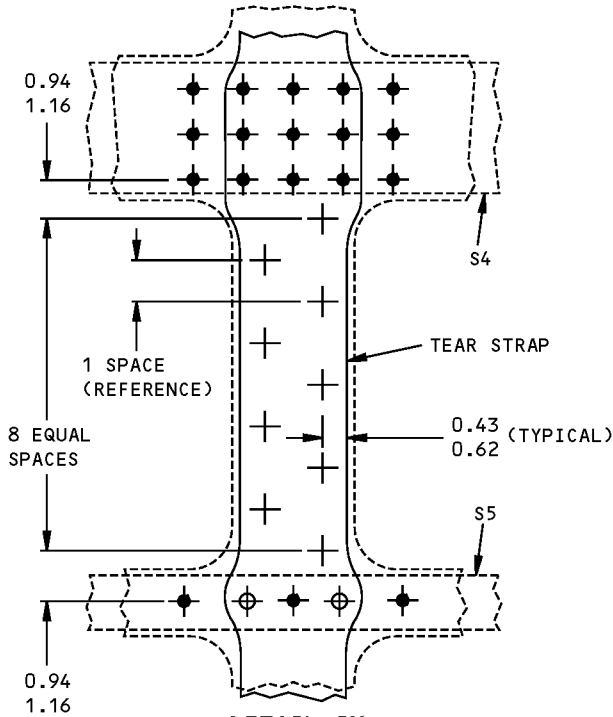
STRUCTURAL REPAIR MANUAL



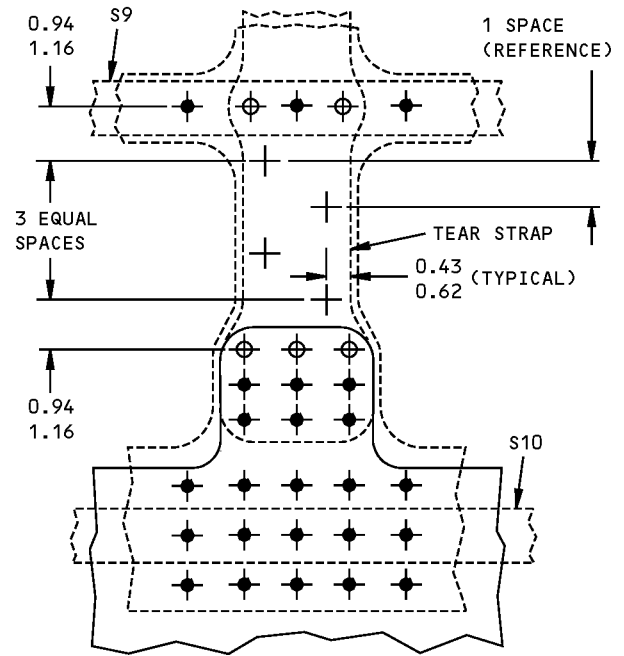
DETAIL VII



DETAIL VIII



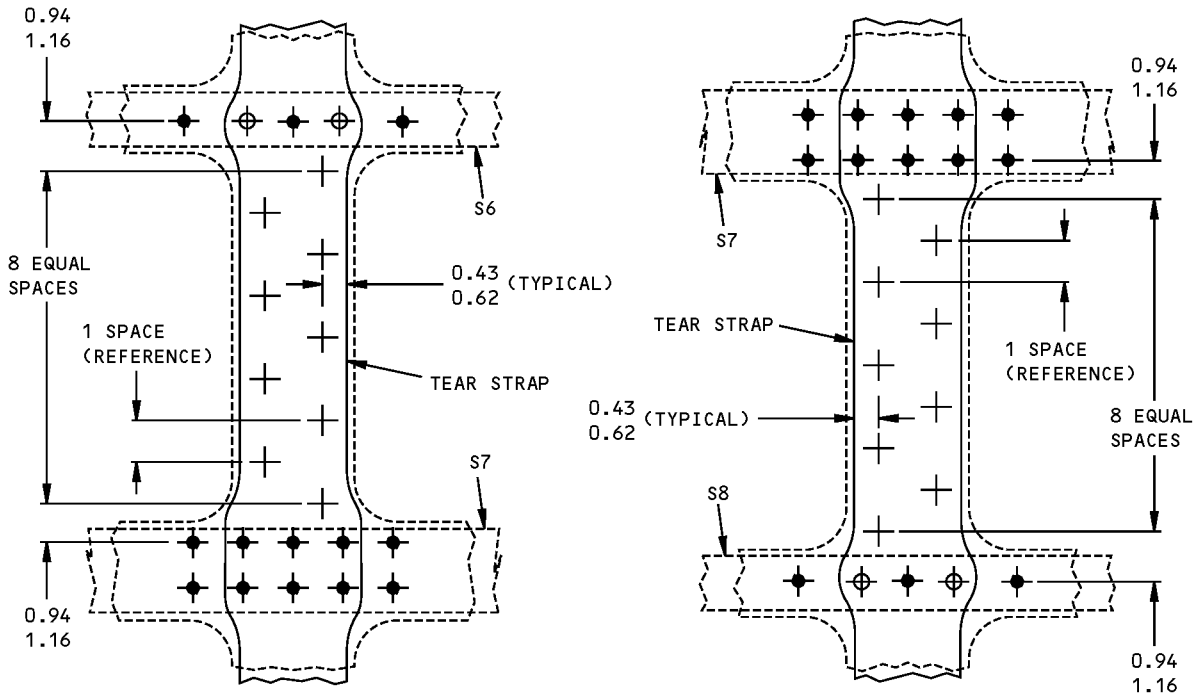
DETAIL IX



DETAIL X

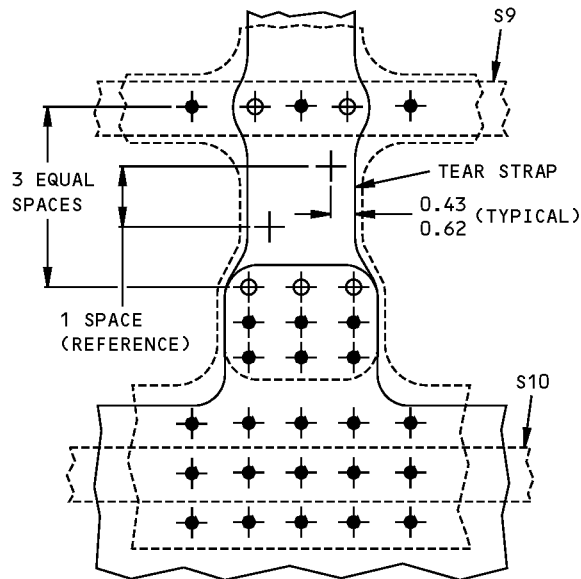
Repair of Skin Tear Strap Disbond Between Stringers 10L and 10R - Section 43 and 46
Figure 201 (Sheet 6 of 7)

**757-200
STRUCTURAL REPAIR MANUAL**



DETAIL XI

DETAIL XII



DETAIL XIII

STA 1380 SHOWN, STA 1400 SIMILAR

**Repair of Skin Tear Strap Disbond Between Stringers 10L and 10R - Section 43 and 46
Figure 201 (Sheet 7 of 7)**

STRUCTURAL REPAIR MANUAL

REPAIR 13 - FUSELAGE SKIN - EXTERNAL REPAIR FOR DAMAGE AT A STRINGER WITH BLIND FASTENERS

APPLICABILITY
<p>THIS CATEGORY C REPAIR IS APPLICABLE TO DAMAGE AT A STRINGER IN ZONES A AND B. CATEGORY C REPAIRS ARE NOT PERMITTED IN ZONE C. C D</p> <p>THIS REPAIR IS NOT APPLICABLE TO:</p> <ul style="list-style-type: none"> - DAMAGE WHERE THE SKIN THICKNESS IS THICKER THAN 0.080 INCH - AREAS WHERE THE INITIAL FASTENERS ARE LARGER THAN 6/32 INCH DIAMETER - DAMAGE THAT EXTENDS TO MORE THAN ONE STRINGER OR FRAME - DAMAGE AT OR ADJACENT TO A TEARSTRAP OR WHERE THE REQUIRED FASTENERS WOULD BE INSTALLED THROUGH A TEARSTRAP E - DAMAGE AT A SKIN SPLICE WHERE THE REQUIRED REPAIR DOUBLER FASTENERS WOULD PICK UP THE EXISTING SPLICE FASTENERS - DAMAGE NEAR THE STATIC PORTS OR ANGLE OF ATTACK SENSORS A - DAMAGE ADJACENT TO ANOTHER REPAIR (INTERNAL OR EXTERNAL) WHERE EDGES OF EACH REPAIR ARE: <ul style="list-style-type: none"> - WITHIN 10 INCHES CIRCUMFERENTIALLY - WITHIN 20 INCHES LONGITUDINALLY - WITHIN 20 INCHES OF A DOOR CUTOUT - DAMAGE AT THE WINDOW BELT (FROM STRINGER S-10 TO S-14 LEFT/RIGHT). - DAMAGE AT OR ADJACENT TO KEEL BEAM RUNOUTS, AT STRINGERS S-28R AND S-28L FROM BS 660 TO BS 900, AND AT S-29L AND S-29R FROM BS 1180 TO BS 1459.

4. Do a High Frequency Eddy Current (HFEC) inspection along the edge of the cutout. Make sure there are no cracks. If there is no more damage, make the cutout larger by 0.04 inch. All cutout edges must have a finish of 63 microinches Ra or better. Refer to 757 NDT part 6, 51-00-01 for the HFEC procedure.
5. Make the repair parts as given in Table I. Pre-form the repair doubler to the fuselage contour. Drill the appropriate fastener holes. Use a drill stop to restrict penetration through skin to 0.06 maximum.
6. Apply a chemical conversion coating to the repair parts and bare surfaces of the skin and stringer.
7. Apply two coats of BMS 10-79, Type II or III primer to the repair parts and bare surfaces of the skin and stringer. Refer to SOPM 20-44-04.
8. Install the repair parts with BMS 5-95 sealant making faying surface seals between all parts in accordance with SRM 51-20-05. A bead of sealant should be apparent all around repair parts after installation. Where there is sufficient sealant squeezed out, it may be formed into a fillet, otherwise an additional fillet seal should be applied.
9. Install the fasteners given in Table II or Table III. Install the fasteners wet with BMS 5-95 sealant.
10. Restore surface finish in accordance with AMM 51-21.

NOTES

- THE BLIND FASTENER REPAIR IS CATEGORY C. THE CATEGORY C REPAIR HAS FAA APPROVAL IF YOU DO THE INSPECTIONS AT THE SPECIFIED THRESHOLD AND INTERVALS AND REPLACE THE REPAIR AT THE SPECIFIED TIME LIMIT, AS GIVEN IN TABLE IV.
- BLIND FASTENER REPAIRS SHOULD NOT BE USED WHERE DOUBLERS, TRIPLERS AND NONTYPICAL STRUCTURE EXIST UNLESS IT CAN BE DEFINITELY ESTABLISHED THAT THE BLIND FASTENER WILL BE PROPERLY SEATED ON THE INTERNAL STRUCTURE AND THAT ADEQUATE RIVET SPACING AND EDGE MARGINS ARE MAINTAINED.
- ALL DIMENSIONS ARE IN INCHES.

REPAIR INSTRUCTIONS

1. Cut out damage to skin to a rectangular shape parallel to the stringer with a minimum corner radius of 0.50 inch.
2. Drill out existing fasteners in the skin to stringer attachment as required.
3. Return all indented or projecting skin to contour. Remove all burrs, nicks, scratches, sharp edges or corners from the damaged area. Make the surface finish of 63 microinches Ra or better.

**Fuselage Skin - External Repair for Damage at a Stringer with Blind Fasteners
Figure 201 (Sheet 1 of 6)**




STRUCTURAL REPAIR MANUAL

NOTES (CONTINUED)

- WHEN YOU USE THIS REPAIR REFER TO:
 - AMM 51-21 FOR INTERIOR AND EXTERIOR FINISHES
 - SOPM 20-44-04 FOR APPLICATION OF URETHANE COMPATIBLE FINISHES
 - SRM 51-00-06 FOR REPAIR CATEGORIES AND DEFINITIONS
 - SRM 51-10-01 FOR AERODYNAMIC SMOOTHNESS REQUIREMENTS
 - SRM 51-10-02 FOR INSPECTION AND REMOVAL OF DAMAGE
 - SRM 51-20-01 FOR PROTECTIVE TREATMENT OF METAL
 - SRM 51-20-05 FOR SEALING OF FUSELAGE SKIN REPAIRS
 - SRM 51-30-01 FOR STANDARD ALUMINUM SHEET METAL GAGES
 - SRM 51-40 FOR FASTENER CODE, REMOVAL, INSTALLATION, HOLE SIZES, EDGE MARGINS, AND SUBSTITUTION
 - SRM 51-40-08 FOR COUNTERSINK WASHERS.

- A** EXTERNAL REPAIRS MAY DISRUPT THE AIRFLOW AROUND STATIC PORTS AND ANGLE OF ATTACK SENSORS ARE NOT ALLOWED IN THESE AREAS. REFER TO SRM 51-10-01 FOR LOCATIONS OF THESE AREAS.
- B** 2P SPACING FOR OUTERMOST CIRCUMFERENTIAL ROWS FOR REPAIRS IN ZONE B. **C**
- C** REFER TO REPAIR/GENERAL FOR DEFINITION OF REPAIR ZONES.
- D** THIS REPAIR MUST BE REPLACED WITH A SOLID FASTENER REPAIR BEFORE THE TIME LIMIT GIVEN IN TABLE IV. REFER TO REPAIR 2 FOR THE CATEGORY B REPAIR INSTRUCTIONS.
- E** REFER TO PRODUCTION DRAWINGS FOR SIZE AND LOCATION OF TEARSTRAPS.
- F** REFER TO SRM 51-30-01, FIGURE 2/GENERAL FOR MOST AVAILABLE STANDARD ALUMINUM SHEET METAL GAGES.

FASTENER SYMBOLS

-  REFERENCE FASTENER LOCATIONS
-  REPAIR FASTENER LOCATIONS
-  INITIAL STRINGER FASTENER LOCATIONS. BLIND FASTENERS CAN ONLY BE USED WHERE THE INITIAL FASTENER IS A RIVET. USE BA15FR(>)E BLIND RIVETS SAME NOMINAL SIZE AS INITIAL RIVETS (THIS IS A 1/64 INCH OVERSIZE FASTENER). DO NOT REPLACE BOLTS OR FASTENERS COMMON TO A SKIN OR STRINGER SPLICE WITH BLIND RIVETS.

REPAIR MATERIAL			
	PART	QTY	MATERIAL
1	DOUBLER	1	SAME MATERIAL AND ONE STANDARD GAGE THICKER THAN THE THICKEST TRIMMED SKIN THICKNESS. MINIMUM DOUBLER GAGE IS 0.050 INCH. F
2	FILLER	1	SAME MATERIAL AND THICKNESS AS INITIAL SKIN

MATERIAL REQUIREMENTS FOR REPAIRS IN ZONES A AND B **C TABLE I**

**Fuselage Skin - External Repair for Damage at a Stringer with Blind Fasteners
Figure 201 (Sheet 2 of 6)**



**757-200
STRUCTURAL REPAIR MANUAL**

INITIAL MINIMUM SKIN POCKET THICKNESS IN REPAIR AREA (INCH)	FASTENERS	NUMBER OF ROWS		SPACING (P) (INCH)
		LONGITUDINAL	CIRCUMFERENTIAL	
0.040	BACR15FR4E	3	3	0.63 TO 0.75
0.045	BACR15FR4E	3	3	0.63 TO 0.75
0.050	BACR15FR4E	3	3	0.63 TO 0.74
0.056	BACR15FR5E	3	3	0.75 TO 0.94
0.063	BACR15FR5E	3	3	0.75 TO 0.91
0.071	BACR15FR5E	3	3	0.75 TO 0.87
0.080	BACR15FR6E	3	3	0.87 TO 1.01

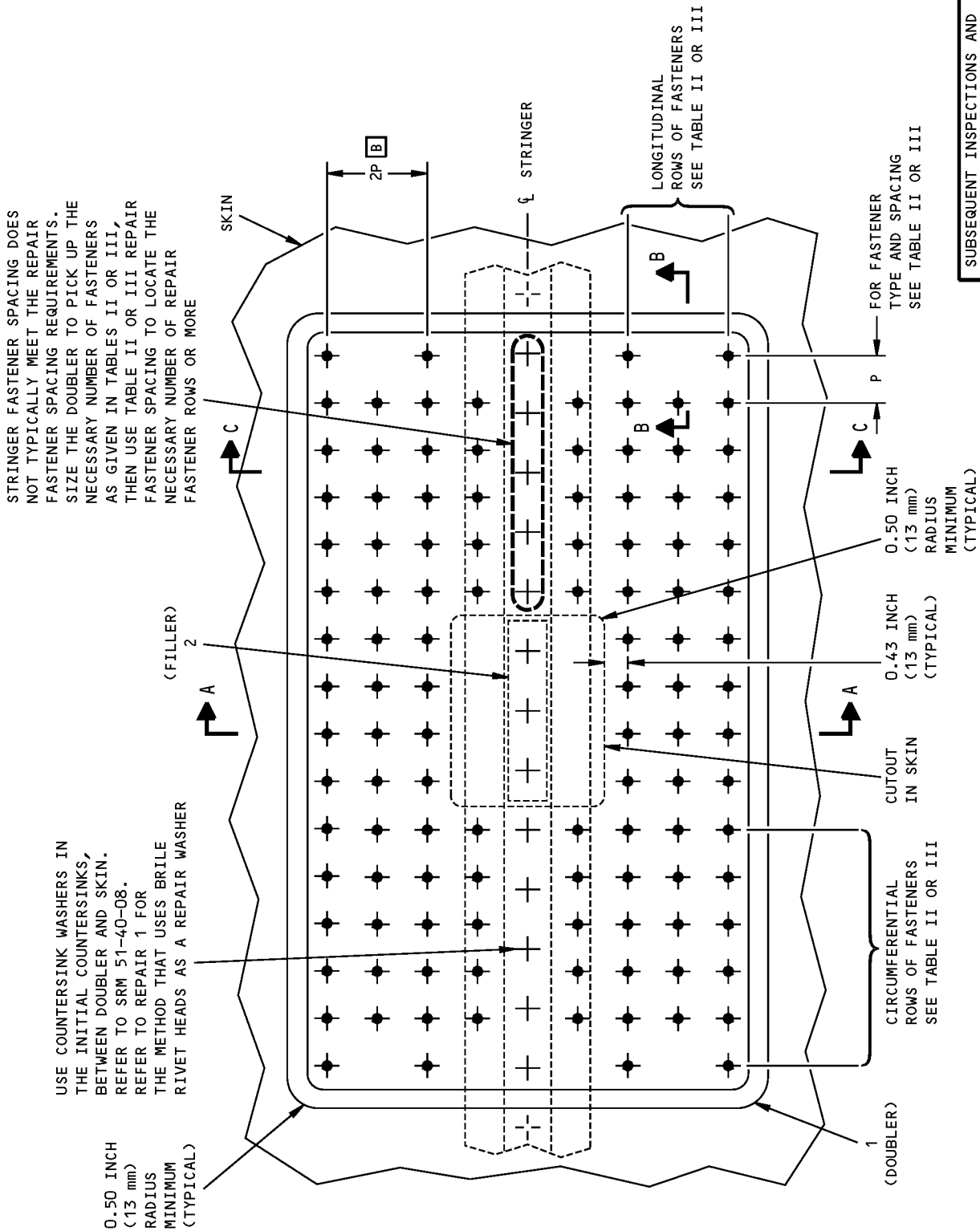
FASTENER REQUIREMENTS FOR REPAIRS IN ZONE A **C**
TABLE II

INITIAL MINIMUM SKIN POCKET THICKNESS IN REPAIR AREA (INCH)	FASTENERS	NUMBER OF ROWS		SPACING B (P) (INCH)
		LONGITUDINAL	CIRCUMFERENTIAL	
0.040	BACR15FR4E	3	5	0.63 TO 0.75
0.045	EACR15FR4E	3	5	0.63 TO 0.75
0.050	BACR15FR4E	3	5	0.63 TO 0.74
0.056	BACR15FR5E	3	5	0.75 TO 0.94
0.063	BACR15FR5E	3	5	0.75 TO 0.91
0.071	BACR15FR5E	3	5	0.75 TO 0.87
0.080	BACR15FR6E	3	5	0.87 TO 1.01

FASTENER REQUIREMENTS FOR REPAIRS IN ZONE B **C**
TABLE III

**Fuselage Skin - External Repair for Damage at a Stringer with Blind Fasteners
Figure 201 (Sheet 3 of 6)**

STRUCTURAL REPAIR MANUAL

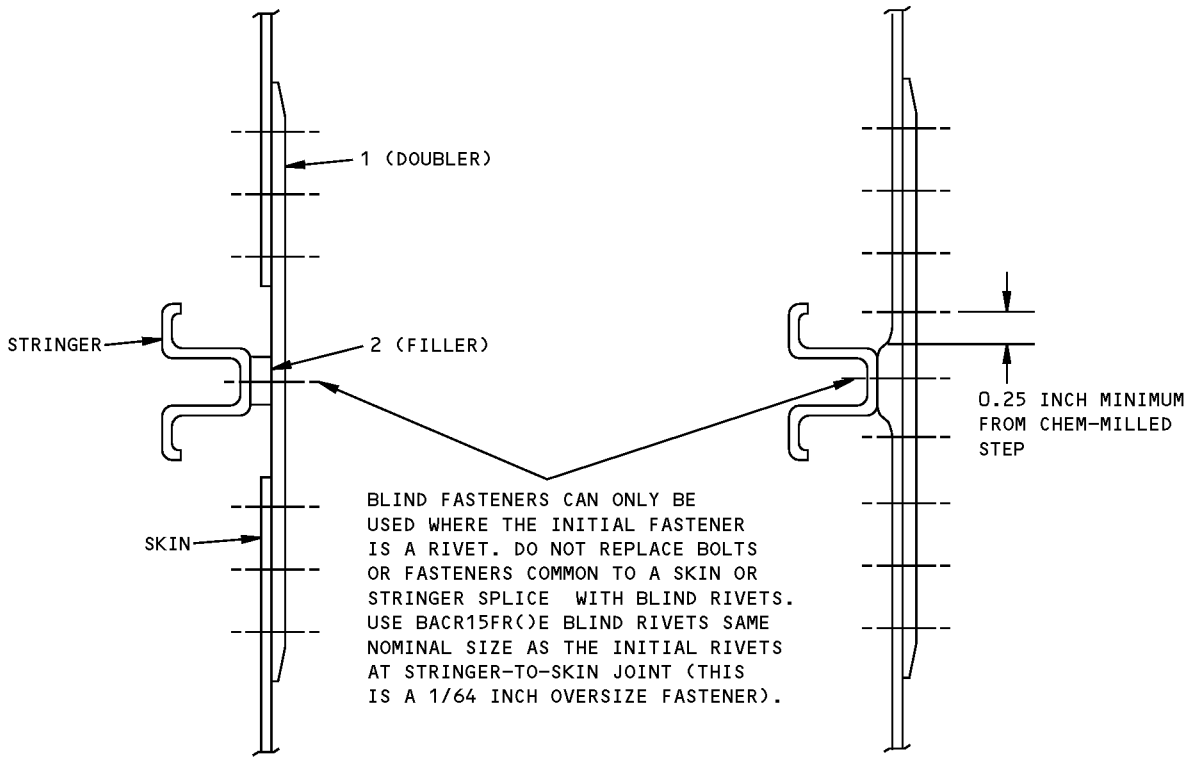


SUBSEQUENT INSPECTIONS AND A TIME LIMIT ARE NECESSARY FOR A CATEGORY C REPAIR. SEE TABLE IV.

DETAIL I

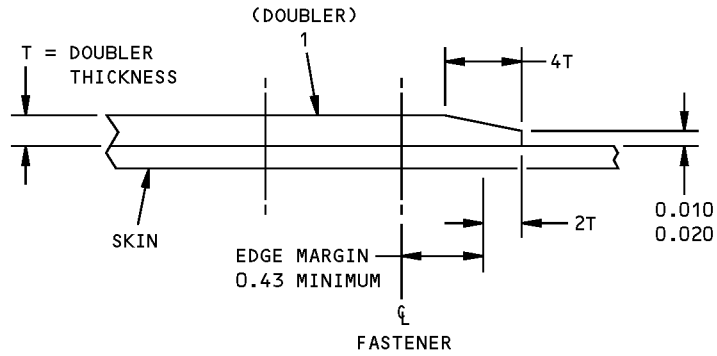
Fuselage Skin - External Repair for Damage at a Stringer with Blind Fasteners
Figure 201 (Sheet 4 of 6)

**757-200
STRUCTURAL REPAIR MANUAL**



SECTION A-A

SECTION C-C



SECTION B-B

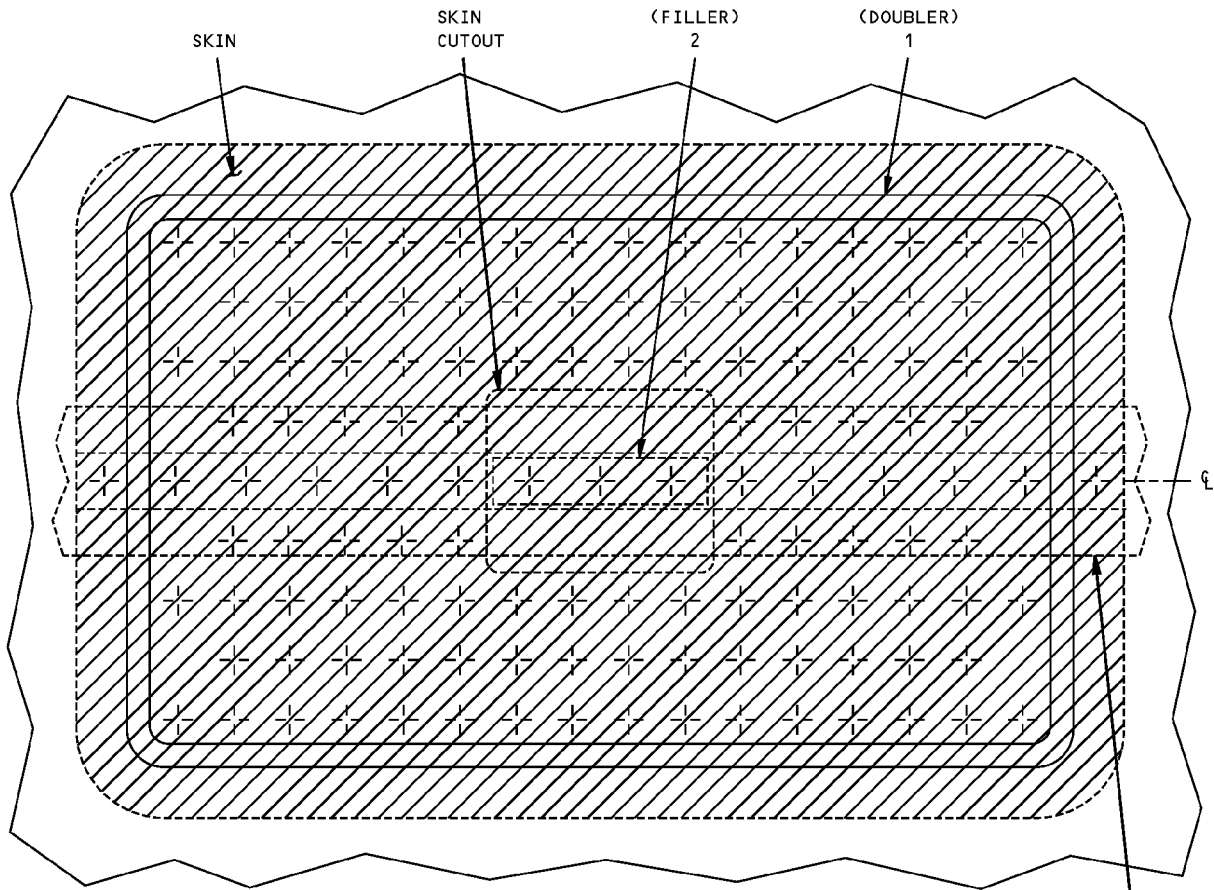
**Fuselage Skin - External Repair for Damage at a Stringer with Blind Fasteners
Figure 201 (Sheet 5 of 6)**

**757-200
STRUCTURAL REPAIR MANUAL**

CATEGORY C REPAIR INSPECTION AND REPLACEMENT REQUIREMENTS			
INSPECTION THRESHOLD	REPEAT INSPECTION		TIME LIMIT
	METHOD	INTERVAL	
1,000 FLIGHT CYCLES	DETAILED VISUAL	1,000 FLIGHT CYCLES	3,000 FLIGHT CYCLES D

NOTE: INSPECT THE 2 INCH WIDE ZONE AROUND THE DOUBLER FOR SKIN DAMAGE AND INSPECT THE DOUBLER FOR MISSING OR LOOSE FASTENERS. IF FOUND, REPLACE THE FASTENER. REFER TO DETAIL II FOR THE AREA WHERE THE EXTERNAL DETAILED VISUAL INSPECTION IS NECESSARY.

TABLE IV



EXTERNAL DETAILED VISUAL INSPECTION AREA
(INCLUDES 2.0 INCHES AROUND THE DOUBLER)

DETAIL II

**Fuselage Skin - External Repair for Damage at a Stringer with Blind Fasteners
Figure 201 (Sheet 6 of 6)**

STRUCTURAL REPAIR MANUAL

REPAIR 14 - FUSELAGE SKIN - EXTERNAL REPAIR FOR DAMAGE BETWEEN STRINGERS WITH BLIND FASTENERS

APPLICABILITY
<p>THIS CATEGORY C REPAIR IS APPLICABLE TO DAMAGE BETWEEN STRINGERS IN ZONES A AND B. CATEGORY C REPAIRS ARE NOT PERMITTED IN ZONE C. C E</p> <p>THIS REPAIR IS NOT APPLICABLE TO:</p> <ul style="list-style-type: none"> - DAMAGE WHERE THE SKIN THICKNESS IS THICKER THAN 0.080 INCH - AREAS WHERE THE INITIAL FASTENERS ARE LARGER THAN 6/32 INCH DIAMETER - DAMAGE THAT EXTENDS TO MORE THAN ONE STRINGER OR FRAME - DAMAGE AT OR ADJACENT TO A TEARSTRAP OR WHERE THE REQUIRED FASTENERS WOULD BE INSTALLED THROUGH A TEARSTRAP G - DAMAGE AT A SKIN SPLICE WHERE THE REQUIRED REPAIR DOUBLER FASTENERS WOULD PICK UP THE EXISTING SPLICE FASTENERS - DAMAGE NEAR THE STATIC PORTS OR ANGLE OF ATTACK SENSORS A - DAMAGE ADJACENT TO ANOTHER REPAIR (INTERNAL OR EXTERNAL) WHERE EDGES OF EACH REPAIR ARE: <ul style="list-style-type: none"> - WITHIN 10 INCHES CIRCUMFERENTIALLY - WITHIN 20 INCHES LONGITUDINALLY - WITHIN 20 INCHES OF A DOOR CUTOUT - DAMAGE AT THE WINDOW BELT (FROM STRINGER S-10 TO S-14 LEFT/RIGHT). - DAMAGE AT OR ADJACENT TO THE KEEL BEAM RUNOUTS AT STRINGERS S-28R AND S-28L FROM BS 660 TO BS 900, AND S-29R AND S-29L FROM BS 1180 TO BS 1459.

4. Make the repair parts as given in Table I. Pre-form the repair doubler to the fuselage contour. Drill the appropriate fastener holes. Use a drill stop to restrict penetration through skin to 0.06 maximum. **D**
5. Apply a chemical conversion coating to the repair parts and bare surfaces of the skin.
6. Apply two coats of BMS 10-79, Type II or III primerto the repair parts and bare surfaces of the skin. Refer to SOPM 20-44-04.
7. Install the repair parts with BMS 5-95 sealant making faying surface seals between all parts in accordance with SRM 51-20-05. A bead of sealant should be apparent all around repair parts after installation. Where there is sufficient sealant squeezed out, it may be formed into a fillet, otherwise an additional fillet seal should be applied.
8. Install the fasteners as given in Table II or Table III. Install the fasteners wet with BMS 5-95 sealant.
9. Restore surface finish in accordance with AMM 51-21.

NOTES

- THE BLIND FASTENER REPAIR IS CATEGORY C. THE CATEGORY C REPAIR HAS FAA APPROVAL IF YOU DO THE INSPECTIONS AT THE SPECIFIED THRESHOLD AND INTERVALS AND REPLACE THE REPAIR AT THE SPECIFIED TIME LIMIT AS GIVEN IN TABLE IV.
- BLIND FASTENER REPAIRS SHOULD NOT BE USED WHERE DOUBLERS, TRIPLERS AND NONTYPICAL STRUCTURE EXIST UNLESS IT CAN BE DEFINATELY ESTABLISHED THAT THE BLIND FASTENER WILL BE PROPERLY SEATED ON THE INTERNAL STRUCTURE AND THAT ADEQUATE RIVET SPACING AND EDGE MARGINS ARE MAINTAINED.
- ALL DIMENSIONS ARE IN INCHES.

REPAIR INSTRUCTIONS

1. Cut out damage to skin to a rectangular shape parallel to the stringer with a minimum corner radius of 0.50 inch.
2. Return all indented or projecting skin to contour. Remove all burrs, nicks, scratches, sharp edges or corners from the damaged area. Make the surface finish of 63 microinches Ra or better.
3. Do a High Frequency Eddy Current (HFEC) inspection along the edge of the cutout. Make sure there are no cracks. If there is no more damage, make the cutout larger by 0.04 inch. All cutout edges must have a finish of 63 microinches Ra or better. Refer to 757 NDT part 6, 51-00-01 for the HFEC procedure.

**Fuselage Skin - External Repair for Damage Between Stringers with Blind Fasteners
Figure 201 (Sheet 1 of 6)**

**757-200
STRUCTURAL REPAIR MANUAL**

NOTES (CONTINUED)

- WHEN YOU USE THIS REPAIR REFER TO:
 - AMM 51-21 FOR INTERIOR AND EXTERIOR FINISHES
 - SOPM 20-44-04 FOR APPLICATION OF URETHANE COMPATIBLE FINISHES
 - SRM 51-00-06 FOR REPAIR CATEGORIES AND DEFINITIONS
 - SRM 51-10-01 FOR AERODYNAMIC SMOOTHNESS REQUIREMENTS
 - SRM 51-10-02 FOR INSPECTION AND REMOVAL OF DAMAGE
 - SRM 51-20-01 FOR PROTECTIVE TREATMENT OF METAL
 - SRM 51-20-05 FOR SEALING OF FUSELAGE SKIN REPAIRS
 - SRM 51-30-01 FOR STANDARD ALUMINUM SHEET METAL GAGES
 - SRM 51-40 FOR FASTENER CODE, REMOVAL, INSTALLATION, HOLE SIZES, EDGE MARGINS AND SUBSTITUTION
 - SRM 51-40-08 FOR COUNTERSINK WASHERS.

FASTENER SYMBOLS

- ⊕ REFERENCE FASTENER LOCATIONS
- ✦ REPAIR FASTENER LOCATIONS
- ⊕ INITIAL STRINGER FASTENER LOCATIONS. BLIND FASTENERS CAN ONLY BE USED WHERE THE INITIAL FASTENER IS A RIVET. USE BACR15FR()E BLIND RIVETS THE SAME NOMINAL SIZE AS THE INITIAL RIVETS (THIS IS A 1/64 INCH OVERSIZE FASTENER). DO NOT REPLACE BOLTS OR FASTENERS COMMON TO A SKIN OR STRINGER SPLICE WITH BLIND RIVETS.

REPAIR MATERIAL			
PART		QTY	MATERIAL
1	DOUBLER	1	SAME MATERIAL AND ONE STANDARD GAGE THICKER THAN THE THICKEST TRIMMED SKIN THICKNESS. MINIMUM DOUBLER GAGE IS 0.050 INCH. [H]

**MATERIAL REQUIREMENTS FOR
REPAIRS IN ZONES A AND B **[C]**
TABLE I**

- [A]** EXTERNAL REPAIRS CAN DISRUPT THE AIRFLOW AROUND STATIC PORTS AND ANGLE OF ATTACK SENSORS. THEREFORE, EXTERNAL REPAIRS ARE NOT PERMITTED IN THESE AREAS. REFER TO SRM 51-10-01 FOR LOCATIONS OF THESE AREAS.
- [B]** 2P SPACING FOR OUTERMOST CIRCUMFERENTIAL ROWS FOR REPAIRS IN ZONE B. **[C]**
- [C]** REFER TO REPAIR GENERAL FOR REPAIR ZONES.
- [D]** DO NOT END THE REPAIR DOUBLER ON A STRINGER OR OTHER INTERNAL STRUCTURE. IF THE LAST ROW OF FASTENERS COMES OVER A STRINGER, THEN ADD ANOTHER FASTENER ROW. THIS WILL MAKE INSPECTABILITY AND DURABILITY OF THE REPAIR BETTER WHEN BLIND FASTENERS ARE REPLACED WITH SOLID FASTENERS.
- [E]** THIS REPAIR MUST BE REPLACED WITH A SOLID FASTENER REPAIR BEFORE THE TIME LIMIT GIVEN IN TABLE IV. REFER TO REPAIR 3 FOR THE CATEGORY B REPAIR INSTRUCTIONS.
- [F]** INSTALL FASTENERS AT ALL REPAIR DOUBLER CORNERS.
- [G]** REFER TO PRODUCTION DRAWINGS FOR SIZE AND LOCATION OF TEARSTRAPS.
- [H]** REFER TO SRM 51-30-01, FIGURE 2/GENERAL FOR MOST AVAILABLE ALUMINUM SHEET METAL GAGES.

**Fuselage Skin - External Repair for Damage Between Stringers with Blind Fasteners
Figure 201 (Sheet 2 of 6)**



**757-200
STRUCTURAL REPAIR MANUAL**

INITIAL MINIMUM SKIN POCKET THICKNESS IN REPAIR AREA	FASTENERS	NUMBER OF ROWS		SPACING (P)
		LONGITUDINAL	CIRCUMFERENTIAL	
0.040	BACR15FR4E	3	3	0.63 TO 0.75
0.045	BACR15FR4E	3	3	0.63 TO 0.75
0.050	BACR15FR4E	3	3	0.63 TO 0.74
0.056	BACR15FR5E	3	3	0.75 TO 0.94
0.063	BACR15FR5E	3	3	0.75 TO 0.91
0.071	BACR15FR5E	3	3	0.75 TO 0.87
0.080	BACR15FR6E	3	3	0.87 TO 1.01

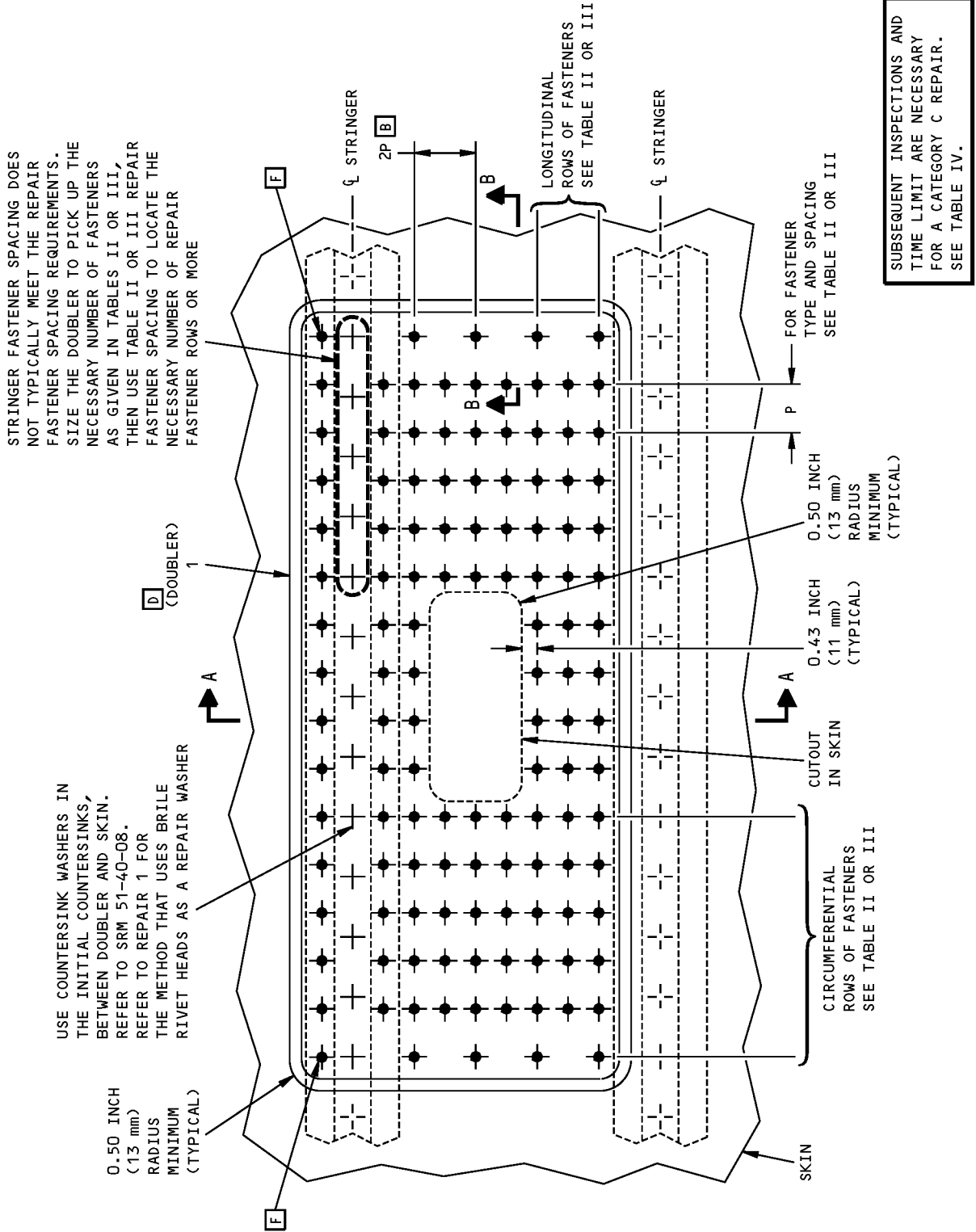
FASTENER REQUIREMENTS FOR REPAIRS IN ZONE A **C**
TABLE II

INITIAL MINIMUM SKIN POCKET THICKNESS IN REPAIR AREA	FASTENERS	NUMBER OF ROWS		SPACING B (P)
		LONGITUDINAL	CIRCUMFERENTIAL	
0.040	BACR15FR4E	3	5	0.63 TO 0.75
0.045	BACR15FR4E	3	5	0.63 TO 0.75
0.050	BACR15FR4E	3	5	0.63 TO 0.74
0.056	BACR15FR5E	3	5	0.75 TO 0.94
0.063	BACR15FR5E	3	5	0.75 TO 0.91
0.071	BACR15FR5E	3	5	0.75 TO 0.87
0.080	BACR15FR6E	3	5	0.87 TO 1.01

FASTENER REQUIREMENTS FOR REPAIRS IN ZONE B **C**
TABLE III

**Fuselage Skin - External Repair for Damage Between Stringers with Blind Fasteners
Figure 201 (Sheet 3 of 6)**

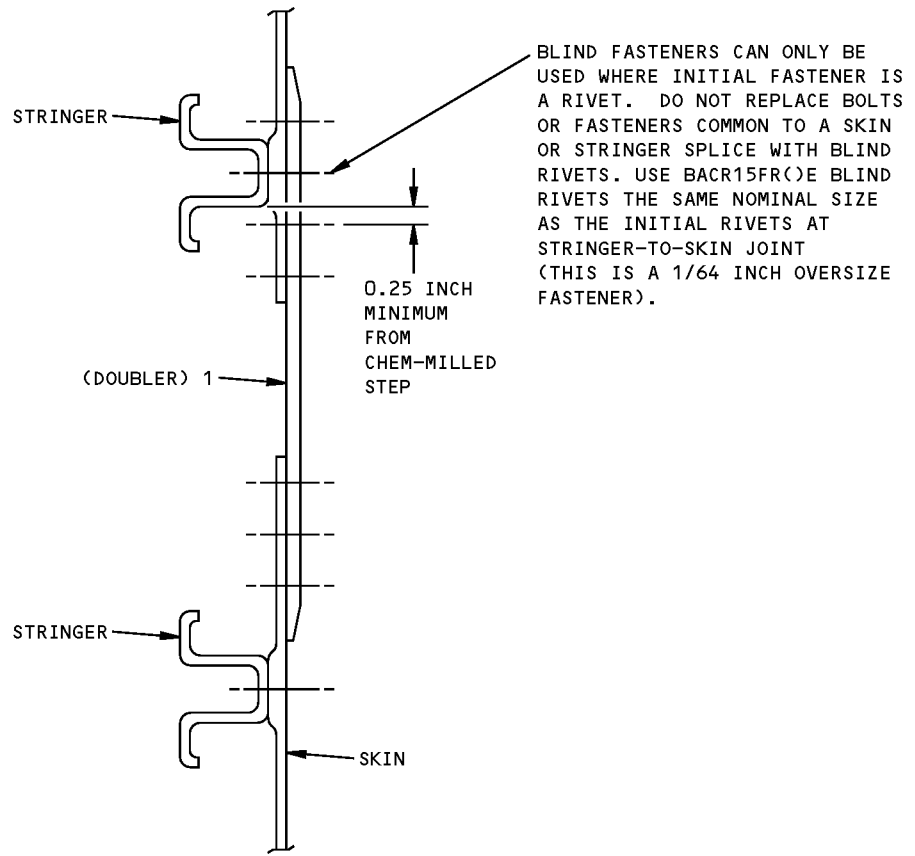
STRUCTURAL REPAIR MANUAL



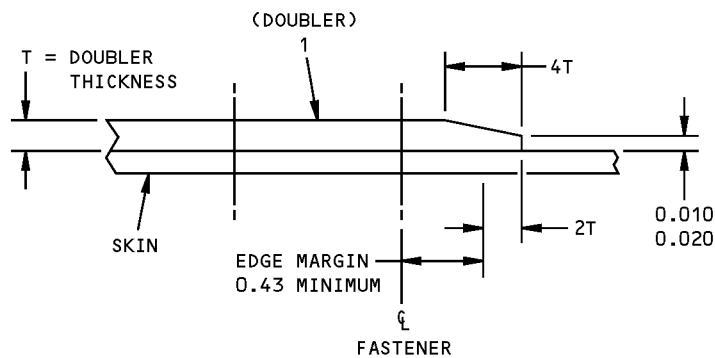
**Fuselage Skin - External Repair for Damage Between Stringers with Blind Fasteners
Figure 201 (Sheet 4 of 6)**

DETAIL I

**757-200
STRUCTURAL REPAIR MANUAL**



SECTION A-A



SECTION B-B

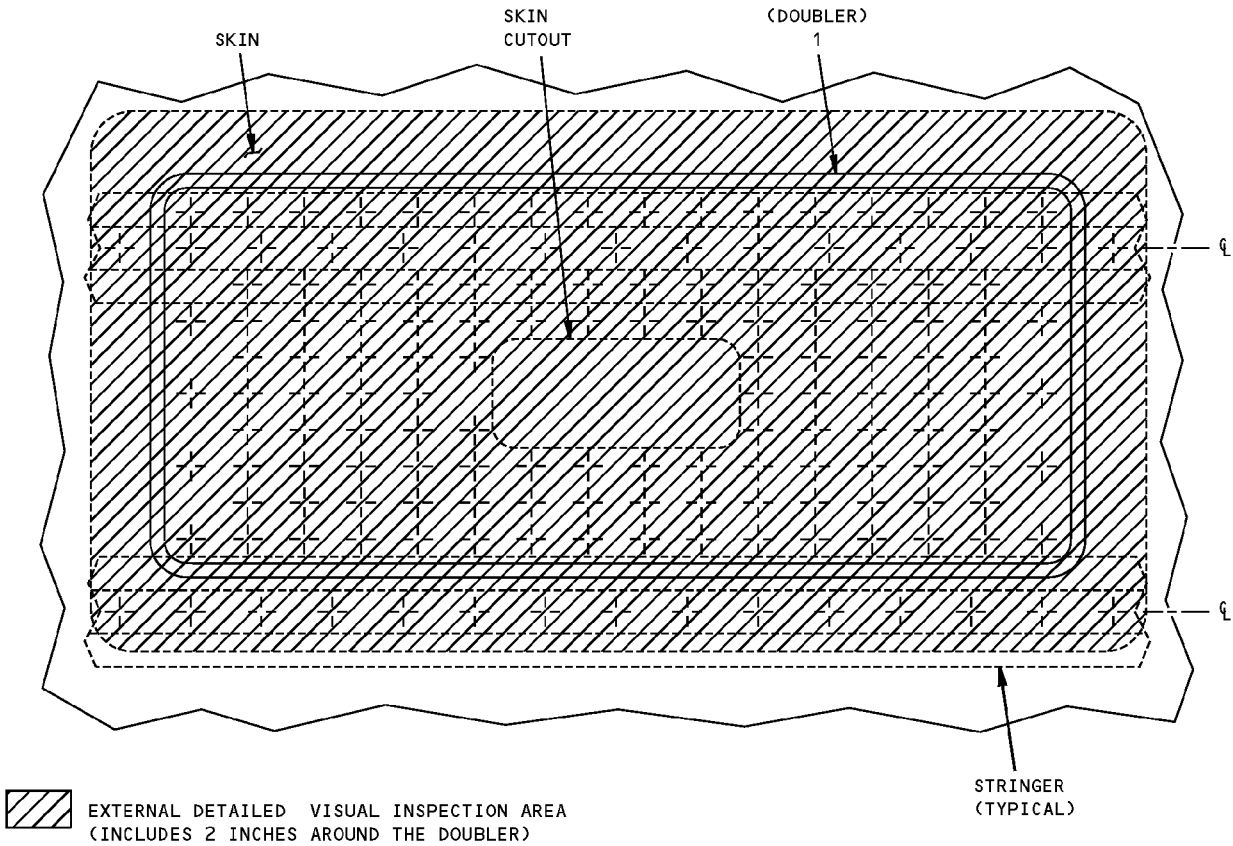
**Fuselage Skin - External Repair for Damage Between Stringers with Blind Fasteners
Figure 201 (Sheet 5 of 6)**

**757-200
STRUCTURAL REPAIR MANUAL**

CATEGORY C REPAIR INSPECTION AND REPLACEMENT REQUIREMENTS			
INSPECTION THRESHOLD	REPEAT INSPECTION		TIME LIMIT
	METHOD	INTERVAL	
1,000 FLIGHT CYCLES	DETAILED VISUAL	1,000 FLIGHT CYCLES	3,000 FLIGHT CYCLES E

NOTE: INSPECT THE 2 INCH WIDE ZONE AROUND THE DOUBLER FOR SKIN DAMAGE AND INSPECT THE DOUBLER FOR MISSING OR LOOSE FASTENERS. IF FOUND, REPLACE THE FASTENER. REFER TO DETAIL II FOR THE AREA WHERE THE EXTERNAL DETAILED VISUAL INSPECTION IS NECESSARY.

TABLE IV



**DETAIL II
Fuselage Skin - External Repair for Damage Between Stringers with Blind Fasteners
Figure 201 (Sheet 6 of 6)**

STRUCTURAL REPAIR MANUAL

REPAIR 15 - FUSELAGE SKIN - EXTERNAL REPAIR FOR DAMAGE AT A STRINGER WITH SOLID FASTENERS -

757-SF

APPLICABILITY
<p>THIS REPAIR APPLIES TO 757-SF AIRPLANES ONLY.</p> <p>THIS CATEGORY B REPAIR IS APPLICABLE TO DAMAGE AT A STRINGER IN ZONES A AND B. CONTACT BOEING FOR REPAIRS IN ZONE C. D</p> <p>THIS REPAIR IS NOT APPLICABLE TO:</p> <ul style="list-style-type: none"> - DAMAGE THAT EXTENDS TO MORE THAN ONE STRINGER OR FRAME - DAMAGE AT OR ADJACENT TO A TEARSTRAP OR WHERE THE REQUIRED FASTENERS WOULD BE INSTALLED THROUGH A TEARSTRAP - DAMAGE AT A SKIN SPLICE WHERE THE REQUIRED REPAIR DOUBLER FASTENERS WOULD PICK UP THE EXISTING SPLICE FASTENERS - DAMAGE NEAR THE STATIC PORTS OR ANGLE OF ATTACK SENSORS B - DAMAGE ADJACENT TO ANOTHER REPAIR (INTERNAL OR EXTERNAL) WHERE EDGES OF EACH REPAIR ARE: <ul style="list-style-type: none"> - WITHIN 10 INCHES (25 cm) CIRCUMFERENTIALLY - WITHIN 20 INCHES (50 cm) LONGITUDINALLY - WITHIN 20 INCHES (50 cm) OF A DOOR CUTOUT - DAMAGE AT THE WINDOW BELT (FROM STRINGER S-10 TO S-14 LEFT/RIGHT).

7. Apply two coats of BMS 10-79, Type II or III primer to the repair parts and bare surfaces of the skin and stringer. Refer to SOPM 20-44-04.
8. Install the repair parts with BMS 5-95 sealant making faying surface seals between all parts in accordance with SRM 51-20-05. A bead of sealant should be apparent all around repair parts after installation. Where there is sufficient sealant squeezed out, it may be formed into a fillet, otherwise an additional fillet seal should be applied.
9. Install the fasteners given in Table III or Table IV.
10. Restore surface finish in accordance with AMM 51-21.

NOTES

- THIS REPAIR IS A CATEGORY B REPAIR IF THE REQUIRED REPAIR DOUBLER THICKNESS IN TABLE I IS NOT MORE THAN THE TABLE II LIMITS. THE CATEGORY B REPAIR HAS FAA APPROVAL IF YOU DO THE INSPECTIONS AT THE SPECIFIED THRESHOLD AND INTERVALS GIVEN IN TABLE V.
- ALL DIMENSIONS ARE IN INCHES.
- D = FASTENER DIAMETER
- WHEN YOU USE THIS REPAIR REFER TO:

REPAIR INSTRUCTIONS

1. Cut out damage to skin to a rectangular shape parallel to the stringer with a minimum corner radius of 0.50 inch (12.7 mm).
2. Drill out existing fasteners in the skin to stringer attachment as required.
3. Return all indented or projecting skin to contour. Remove all burrs, nicks, scratches, sharp edges or corners from the damaged area. Make the surface finish of 63 microinches Ra or better.
4. Do a High Frequency Eddy Current (HFEC) inspection along the edge of the cutout. Make sure there are no cracks. If there is no more damage, make the cutout larger by 0.04 inch (1 mm). All cutout edges must have a finish of 63 microinches Ra or better. Refer to 757 NDT part 6, 51-00-01.
5. Make the repair parts as given in Table I. Pre-form the repair doubler to the fuselage contour. Drill the appropriate fastener holes. Use a drill stop to restrict penetration through skin to 0.06 (1.5 mm) maximum. **A F K**
6. Apply a chemical conversion coating to the repair parts and bare surfaces of the skin and stringer.

- AMM 51-21 FOR INTERIOR AND EXTERIOR FINISHES
- SOPM 20-44-04 FOR APPLICATION OF URETHANE COMPATIBLE FINISHES
- SRM 51-00-06 FOR REPAIR CATEGORIES AND DEFINITIONS
- SRM 51-10-02 FOR INSPECTION AND REMOVAL OF DAMAGE
- SRM 51-10-01 FOR AERODYNAMIC SMOOTHNESS REQUIREMENTS
- SRM 51-20-01 FOR PROTECTIVE TREATMENT OF METAL
- SRM 51-20-05 FOR SEALING OF FUSELAGE SKIN REPAIRS
- SRM 51-20-13 FOR SURFACE ROUGHNESS REQUIREMENTS
- SRM 51-30-01 FOR STANDARD ALUMINUM SHEET METAL GAGES
- SRM 51-40 FOR FASTENER CODE, REMOVAL, INSTALLATION, HOLE SIZES, EDGE MARGINS AND SUBSTITUTION

**Fuselage Skin - External Repair for Damage at a Stringer with Solid Fasteners - 757-SF
Figure 201 (Sheet 1 of 6)**

STRUCTURAL REPAIR MANUAL

NOTES (CONTINUED)




- A** DO NOT END THE REPAIR DOUBLER ON A STRINGER OR OTHER STRUCTURE. ADD AN ADDITIONAL FASTENER ROW TO HAVE A BETTER INTERNAL INSPECTABILITY AND REPAIR DURABILITY.
- B** EXTERNAL REPAIRS CAN DISRUPT THE AIRFLOW AROUND STATIC PORTS AND ANGLE OF ATTACK SENSORS. THEREFORE EXTERNAL REPAIRS ARE NOT PERMITTED IN THESE AREAS. REFER TO SRM 51-10-01 FOR LOCATIONS OF THESE AREAS.
- C** 2P SPACING FOR OUTERMOST CIRCUMFERENTIAL ROWS FOR REPAIRS IN ZONE B. **D**
- D** REFER TO REPAIR GENERAL FOR DEFINITION OF REPAIR ZONES.
- E** LOW FREQUENCY EDDY CURRENT (LFEC) INSPECTION METHOD CAN BE USED ONLY IF THE REPAIR DOUBLER THICKNESS IS LESS THAN 0.11 INCH (2.79 mm).
- F** USE THE EQUIVALENT PROTRUDING HEAD FASTENERS THAT FOLLOW AT INITIAL FASTENER LOCATIONS:

INITIAL FASTENER	EQUIVALENT PROTRUDING HEAD FASTENER
BACR15FV()KE	BACR15FT()KE
BACR15CE()D	BACR15BB()D
BACB30NW()K	BACB30MY()K

- G** IF THE REQUIRED REPAIR DOUBLER THICKNESS IN TABLE I IS MORE THAN THE MAXIMUM THICKNESS PERMITTED IN TABLE II, THEN THE REPAIR IS A CATEGORY C REPAIR. REPLACE THE CATEGORY C REPAIR BEFORE 3,000 FLIGHT CYCLES. CONTACT BOEING FOR ALTERNATIVE CATEGORY B REPAIR.
- H** THE INSPECTION THRESHOLD IS 25,000 TOTAL AIRFRAME CYCLES OR THE NEXT INSPECTION INTERVAL, WHICH EVER OCCURS LATER.
- I** THE INSPECTION THRESHOLD IS BASED ON TOTAL AIRFRAME CYCLES FOR REPAIRS WITH INITIAL FASTENERS IN THE INSPECTION AREA IN ADDITION TO THE TWO STRINGER FASTENERS. SOME AIRPLANES REQUIRING REPAIR MAY HAVE ACCUMULATED A TOTAL NUMBER OF AIRFRAME CYCLES APPROACHING, EQUAL TO, OR GREATER THAN THE SPECIFIED 25,000 OR 37,000 THRESHOLD. FOR REPAIRS ON THOSE AIRPLANES, DO A HIGH FREQUENCY EDDY CURRENT (HFEC) HOLE PROBE INSPECTION OF THE INITIAL FASTENER HOLES AT THE TIME OF REPAIR. IF NO DAMAGE IS EVIDENT, INSTALL THE APPROPRIATE REPAIR FASTENER AND ACCOMPLISH THE INITIAL INSPECTION AT THE FLIGHT CYCLES NOTED FROM TIME OF REPAIR (16,000 OR 29,000 FLIGHT CYCLES BASED ON T SKIN).

- J** THE INSPECTION THRESHOLD IS BASED ON FLIGHT CYCLES FROM TIME OF REPAIR FOR REPAIRS WITH NO INITIAL FASTENERS IN THE INSPECTION AREA EXCEPT THE TWO STRINGER FASTENERS (AT THE FORWARD AND AFT EDGE OF THE REPAIR).
- K** IF THE FASTENER HOLES INTERSECT A CHEM-MILLED STEP, BLEND THE CHEM-MILLED STEP AS GIVEN IN SRM 53-00-01, ALLOWABLE DAMAGE 1, DETAIL II. DO NOT MAKE THE BLEND DEEPER THAN THE DEPTH OF THE SKIN POCKET.
- L** WHEN A BLIND FASTENER IS REPLACED WITH A SOLID FASTENER, THE SOLID FASTENER MUST BE A MINIMUM OF 1/32 INCH LARGER THAN THE NOMINAL SIZE OF THE BLIND FASTENER THAT HAS BEEN REPLACED. **F**
- M** REFER TO SRM 51-30-01, FIGURE 2/GENERAL FOR THE MOST AVAILABLE STANDARD ALUMINUM SHEET METAL GAGES

FASTENER SYMBOLS

-  REFERENCE FASTENER LOCATIONS
-  REPAIR FASTENER LOCATIONS
-  INITIAL FASTENER LOCATION. INSTALL A PROTRUDING HEAD FASTENER OF THE SAME TYPE AND SIZE AS PRODUCTION, 1/32 INCH OVERSIZE IF NECESSARY **F**

**Fuselage Skin - External Repair for Damage at a Stringer with Solid Fasteners - 757-SF
Figure 201 (Sheet 2 of 6)**

STRUCTURAL REPAIR MANUAL

REPAIR MATERIAL			
PART		QTY	MATERIAL
1	DOUBLER	1	SAME MATERIAL AND ONE STANDARD GAGE THICKER THAN THE THICKEST TRIMMED SKIN THICKNESS. MINIMUM DOUBLER GAGE IS 0.050 INCH. [F][G][M]
2	FILLER	1	SAME MATERIAL AND THICKNESS AS INITIAL SKIN

MATERIAL REQUIREMENTS FOR REPAIRS IN ZONES A AND B [D]

TABLE I

REPAIR DOUBLER THICKNESS LIMITATION FOR CATEGORY B REPAIRS	
MINIMUM SKIN GAGE COMMON TO ANY REPAIR FASTENER	MAXIMUM REPAIR DOUBLER GAGE [G]
0.040	0.063
0.045	0.063
0.050	0.071
0.056	0.080
0.063	0.090
0.071	0.100
0.080	0.110
0.090	0.125

TABLE II

INITIAL MINIMUM SKIN POCKET THICKNESS IN REPAIR AREA	FASTENERS [F][L]	NUMBER OF ROWS (SEE DETAIL I)		SPACING (P)
		LONGITUDINAL	CIRCUMFERENTIAL	
0.040	BACR15FT5KE	3	3	0.63 TO 0.91
0.045	BACR15FT5KE	3	3	0.63 TO 0.94
0.050	BACR15FT5KE	3	3	0.63 TO 0.94
0.056	BACR15FT6KE	3	3	0.75 TO 1.13
0.063	BACR15FT6KE	3	3	0.75 TO 1.13
0.071	BACR15FT6KE	3	3	0.75 TO 1.13
0.080	BACR15FT7KE	3	3	0.87 TO 1.30
0.090	BACR15FT8KE	3	3	1.00 TO 1.50

FASTENER REQUIREMENTS FOR REPAIRS IN ZONE A [D]

TABLE III

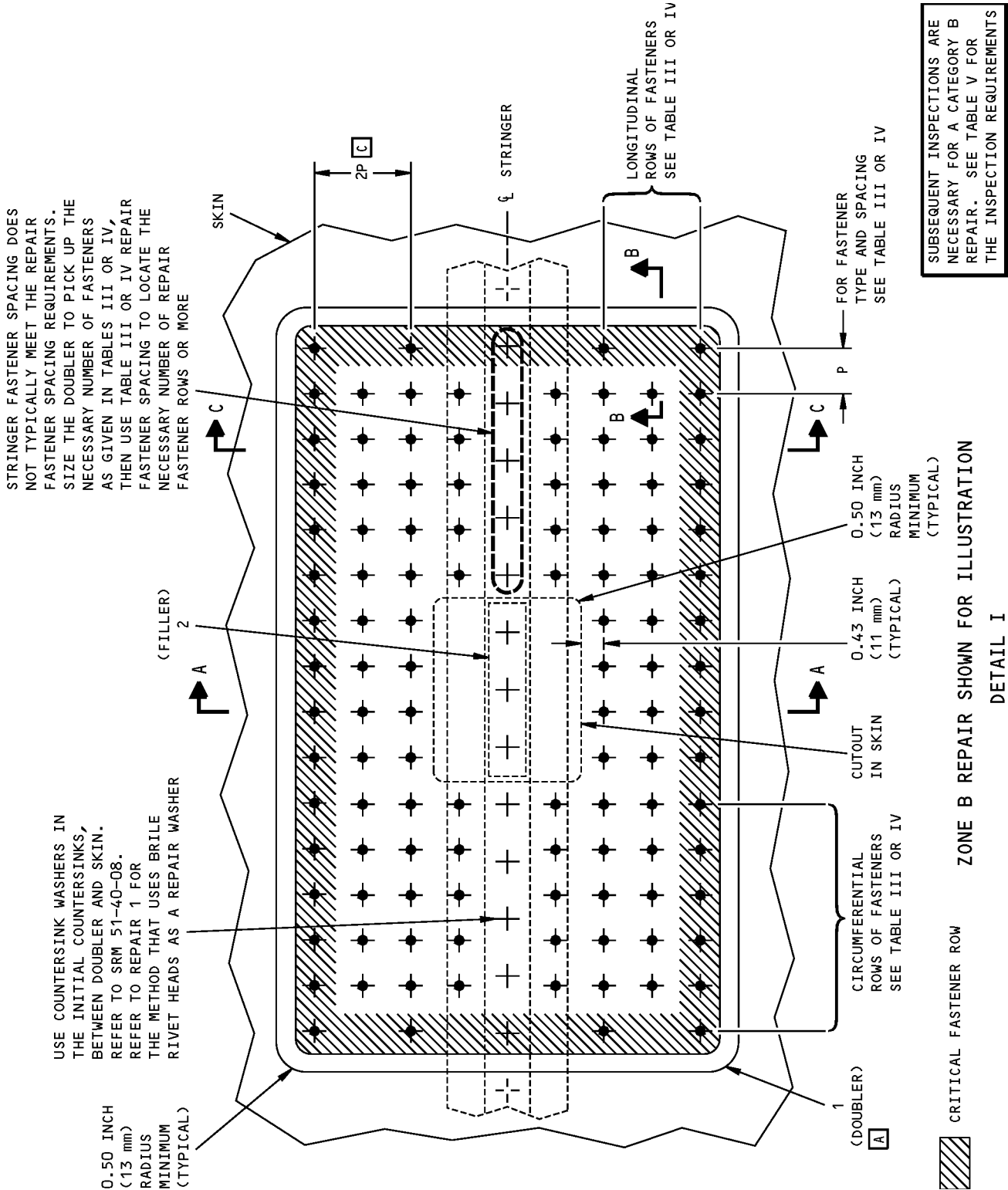
INITIAL MINIMUM SKIN POCKET THICKNESS IN REPAIR AREA	FASTENERS [F][L]	NUMBER OF ROWS (SEE DETAIL I)		SPACING [C] (P)
		LONGITUDINAL	CIRCUMFERENTIAL	
0.040	BACR15FT5KE	3	5	0.63 TO 0.91
0.045	BACR15FT5KE	3	5	0.63 TO 0.94
0.050	BACR15FT5KE	3	5	0.63 TO 0.94
0.056	BACR15FT6KE	3	5	0.75 TO 1.13
0.063	BACR15FT6KE	3	5	0.75 TO 1.13
0.071	BACR15FT6KE	3	5	0.75 TO 1.13
0.080	BACR15FT7KE	3	5	0.87 TO 1.30
0.090	BACR15FT8KE	3	5	1.00 TO 1.50

FASTENER REQUIREMENTS FOR REPAIRS IN ZONE B [D]

TABLE IV

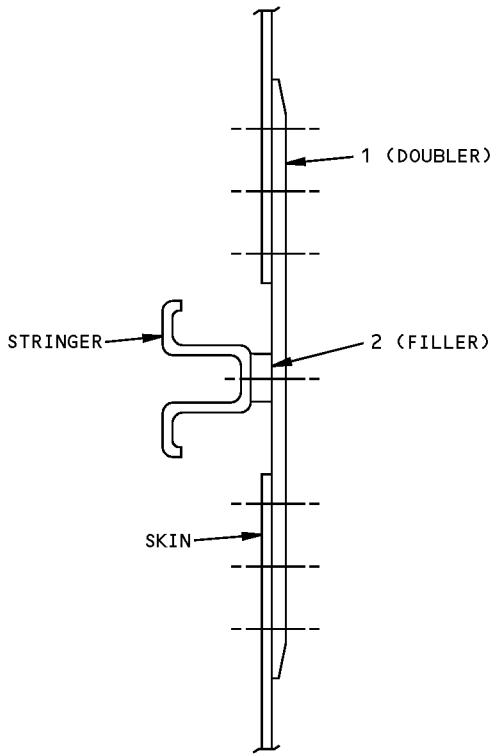
Fuselage Skin - External Repair for Damage at a Stringer with Solid Fasteners - 757-SF
Figure 201 (Sheet 3 of 6)

STRUCTURAL REPAIR MANUAL

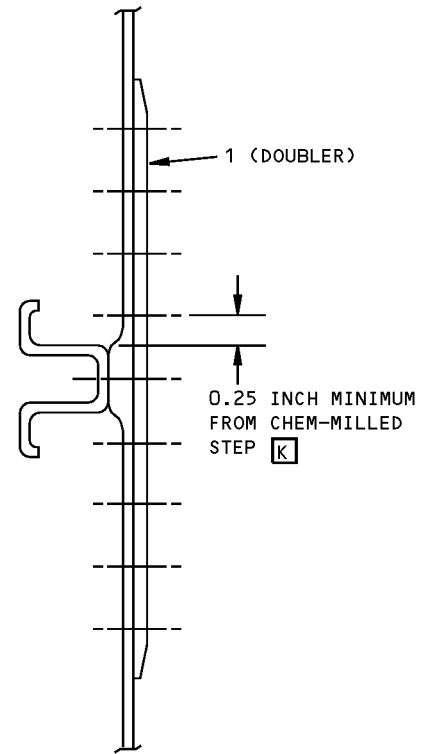


Fuselage Skin - External Repair for Damage at a Stringer with Solid Fasteners - 757-SF
Figure 201 (Sheet 4 of 6)

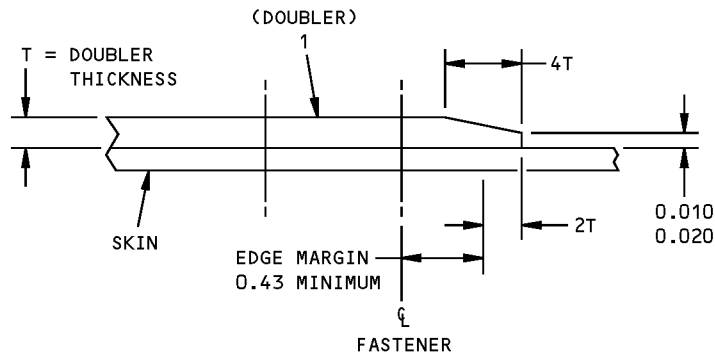
**757-200
STRUCTURAL REPAIR MANUAL**



SECTION A-A



SECTION C-C



SECTION B-B

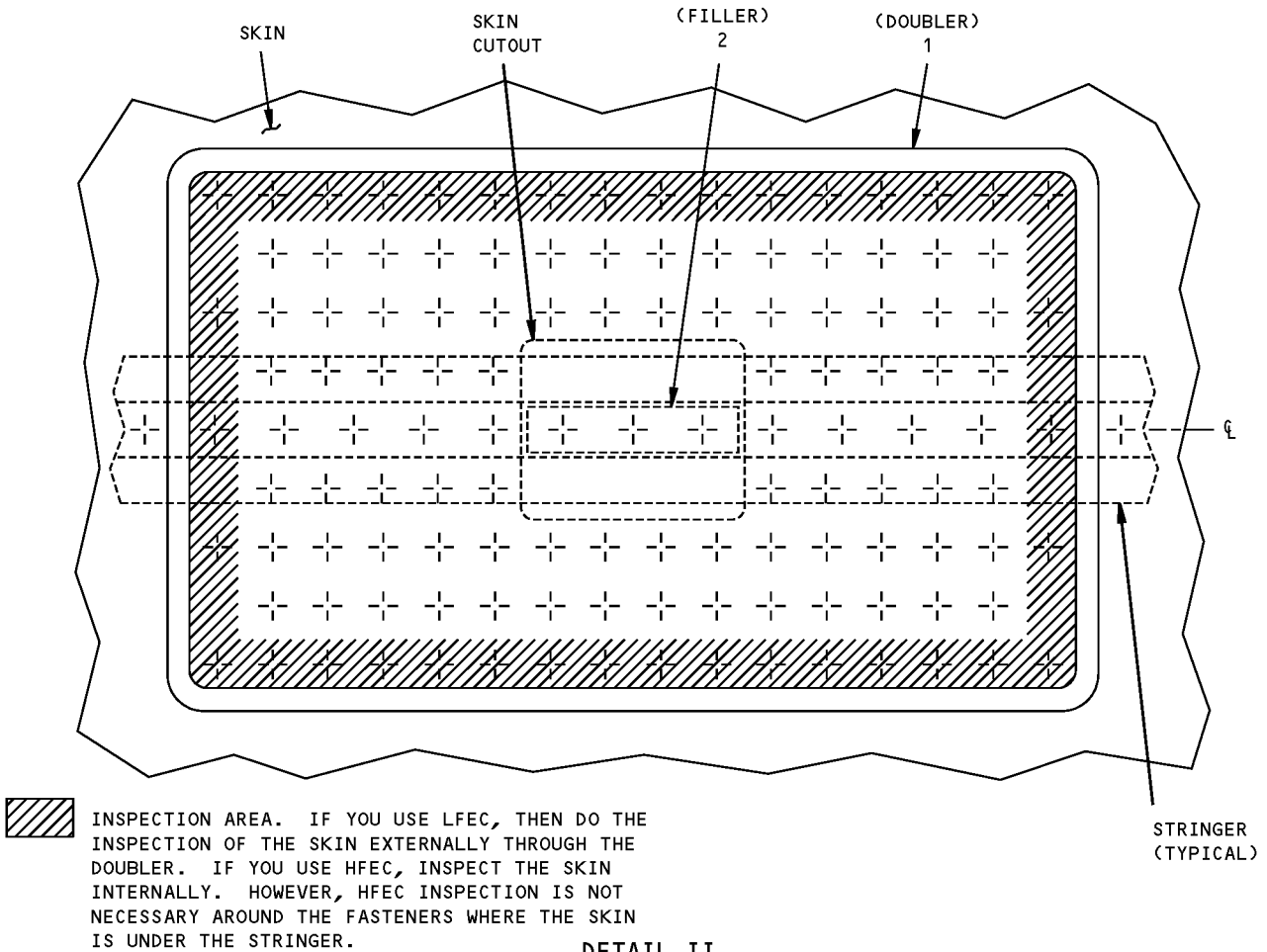
**Fuselage Skin - External Repair for Damage at a Stringer with Solid Fasteners - 757-SF
Figure 201 (Sheet 5 of 6)**

**757-200
STRUCTURAL REPAIR MANUAL**

CATEGORY B REPAIR INSPECTION REQUIREMENTS					
REPAIR ZONES	INSPECTION THRESHOLD (FLIGHT CYCLES)		REPEAT INSPECTION ALTERNATIVES		
	TOTAL FLIGHTS	FROM TIME OF REPAIR	METHOD	INTERVAL	REFERENCE
ZONE B [H]	25,000	SEE REPEAT INSPECTION INTERVALS	HIGH FREQUENCY EDDY CURRENT (HFEC)	6,000	NDT PART 6 51-00-01
ZONE A tSKIN ≤ 0.050 tSKIN ≥ 0.051	[I] 25,000 37,000	[J] 16,000 29,000	LOW FREQUENCY EDDY CURRENT (LFEC) [E]	3,000	NDT PART 6 53-00-06

NOTE: INSPECT THE SKIN AROUND THE FIRST ROW OF FASTENERS ALONG THE EDGE OF THE DOUBLER AS SHOWN IN DETAIL II. USE ONE OF THE TWO INSPECTION METHODS.

TABLE V



**Fuselage Skin - External Repair for Damage at a Stringer with Solid Fasteners - 757-SF
Figure 201 (Sheet 6 of 6)**

STRUCTURAL REPAIR MANUAL

REPAIR 16 - FUSELAGE SKIN - EXTERNAL REPAIR FOR DAMAGE BETWEEN STRINGERS WITH SOLID FASTENERS - 757-SF

APPLICABILITY
<p>THIS REPAIR APPLIES TO 757-SF AIRPLANES ONLY.</p> <p>THIS CATEGORY B REPAIR IS APPLICABLE TO DAMAGE BETWEEN STRINGERS IN ZONES A AND B. CONTACT BOEING FOR REPAIRS IN ZONE C. D</p> <p>THIS REPAIR IS NOT APPLICABLE TO:</p> <ul style="list-style-type: none"> - DAMAGE THAT EXTENDS TO MORE THAN ONE STRINGER OR FRAME - DAMAGE AT OR ADJACENT TO A TEARSTRAP OR WHERE THE REQUIRED FASTENERS WOULD BE INSTALLED THROUGH A TEARSTRAP - DAMAGE AT A SKIN SPLICE WHERE THE REQUIRED REPAIR DOUBLER FASTENERS WOULD PICK UP THE EXISTING SPLICE FASTENERS - DAMAGE NEAR THE STATIC PORTS OR ANGLE OF ATTACK SENSORS B - DAMAGE ADJACENT TO ANOTHER REPAIR (INTERNAL OR EXTERNAL) WHERE EDGES OF EACH REPAIR ARE: <ul style="list-style-type: none"> - WITHIN 10 INCHES (25 cm) CIRCUMFERENTIALLY - WITHIN 20 INCHES (50 cm) LONGITUDINALLY - WITHIN 20 INCHES (50 cm) OF A DOOR CUTOUT - DAMAGE AT THE WINDOW BELT (FROM STRINGER S-10 TO S-14 LEFT/RIGHT).

5. Apply a chemical conversion coating to the repair parts and bare surfaces of the skin.
6. Apply two coats of BMS 10-79, Type II or III primer to the repairs parts and bare surfaces of the skin. Refer to SOPM 20-44-04.
7. Install the repair parts with BMS 5-95 sealant making faying surface seals between all parts in accordance with SRM 51-20-05. A bead of sealant should be apparent all around repair parts after installation. Where there is sufficient sealant squeezed out, it may be formed into a fillet, otherwise an additional fillet seal should be applied.
8. Install the fasteners as given in Table III or Table IV.
9. Restore surface finish in accordance with AMM 51-21.

NOTES

- THIS REPAIR IS A CATEGORY B REPAIR IF THE REQUIRED DOUBLER THICKNESS IN TABLE I IS NOT MORE THAN THE TABLE II LIMITS. THE CATEGORY B REPAIR HAS FAA APPROVAL IF YOU DO THE INSPECTIONS AT THE SPECIFIED THRESHOLD AND INTERVALS AS GIVEN IN TABLE V.
- ALL DIMENSIONS ARE IN INCHES.
- D = FASTENER DIAMETER
- WHEN YOU USE THIS REPAIR REFER TO:
 - AMM 51-21 FOR INTERIOR AND EXTERIOR FINISHES
 - SOPM 20-44-04 FOR APPLICATION OF URETHANE COMPATIBLE FINISHES
 - SRM 51-00-06 FOR REPAIR CATEGORIES AND DEFINITIONS
 - SRM 51-10-01 FOR AERODYNAMIC SMOOTHNESS REQUIREMENTS
 - SRM 51-10-02 FOR INSPECTION AND REMOVAL OF DAMAGE
 - SRM 51-20-01 FOR PROTECTIVE TREATMENT OF METAL
 - SRM 51-20-13 FOR SURFACE ROUGHNESS REQUIREMENTS
 - SRM 51-30-01 FOR STANDARD ALUMINUM SHEET METAL GAGES
 - SRM 51-20-05 FOR SEALING OF FUSELAGE SKIN REPAIRS
 - SRM 51-40 FOR FASTENER CODE, REMOVAL, INSTALLATION, HOLE SIZES, EDGE MARGINS AND SUBSTITUTION

REPAIR INSTRUCTIONS

1. Cut out damage to skin to a rectangular shape parallel to the stringer with a minimum corner radius of 0.50 inch (12.7 mm).
2. Return all indented or projecting skin to contour. Remove all burrs, nicks, scratches, sharp edges or corners from the damaged area. Make the surface finish of 63 microinches Ra or better.
3. Do a High Frequency Eddy Current (HFEC) inspection along the edge of the cutout. Make sure there are no cracks. If there is no more damage, make the cutout larger by 0.04 inch (1 mm). All cutout edges must have a finish of 63 microinches Ra or better. Refer to 757 NDT part 6, 51-00-01.
4. Make the repair parts as given in Table I. Pre-form the repair doubler to the fuselage contour. Drill the appropriate fastener holes. Use a drill stop to restrict penetration through skin to 0.06 (1.5 mm) maximum. **A F K**

**Fuselage Skin - External Repair for Damage Between Stringers with Solid Fasteners - 757-SF
Figure 201 (Sheet 1 of 6)**

STRUCTURAL REPAIR MANUAL

NOTES (CONTINUED)




- A** DO NOT END THE REPAIR DOUBLER ON A STRINGER OR OTHER STRUCTURE. IF THE LAST ROW OF FASTENERS COMES OVER A STRINGER, THEN ADD AN ADDITIONAL FASTENER ROW TO HAVE A BETTER INTERNAL INSPECTABILITY AND REPAIR DURABILITY.
- B** EXTERNAL REPAIRS CAN DISRUPT THE AIRFLOW AROUND STATIC PORTS AND ANGLE OF ATTACK SENSORS. THEREFORE, EXTERNAL REPAIRS ARE NOT PERMITTED IN THESE AREAS. REFER TO SRM 51-10-01 FOR LOCATIONS OF THESE AREAS.
- C** 2P SPACING FOR OUTERMOST CIRCUMFERENTIAL ROWS FOR REPAIRS IN ZONE B. **D**
- D** REFER TO REPAIR GENERAL FOR DEFINITION OF REPAIR ZONES.
- E** LOW FREQUENCY EDDY CURRENT (LFEC) INSPECTION METHOD CAN BE USED ONLY IF THE REPAIR DOUBLER THICKNESS IS LESS THAN 0.11 INCH (2.79 mm).
- F** USE THE EQUIVALENT PROTRUDING HEAD FASTENERS THAT FOLLOW AT INITIAL FASTENER LOCATIONS:

INITIAL FASTENER	EQUIVALENT PROTRUDING HEAD FASTENER
BACR15FV(>)KE	BACR15FT(>)KE
BACR15CE(>)D	BACR15BB(>)D
BACB30NW(>)K	BACB30MY(>)K

- G** IF THE REQUIRED REPAIR DOUBLER THICKNESS IN TABLE I IS MORE THAN THE MAXIMUM THICKNESS PERMITTED IN TABLE II, THEN THE REPAIR IS A CATEGORY C REPAIR. REPLACE THE CATEGORY C REPAIR BEFORE 3,000 FLIGHT CYCLES. CONTACT BOEING FOR ALTERNATIVE CATEGORY B REPAIR.
- H** THE INSPECTION THRESHOLD IS 25,000 TOTAL AIRFRAME CYCLES OR THE NEXT INSPECTION INTERVAL WHICHEVER OCCURS LATER.
- I** THE INSPECTION THRESHOLD IS BASED ON TOTAL AIRFRAME CYCLES FOR REPAIRS WITH INITIAL FASTENERS IN THE INSPECTION AREA IN ADDITION TO THE TWO STRINGER FASTENERS. SOME AIRPLANES REQUIRING REPAIR MAY HAVE ACCUMULATED A TOTAL NUMBER OF AIRFRAME CYCLES APPROACHING, EQUAL TO OR GREATER THAN THE SPECIFIED 25,000 OR 37,500 THRESHOLD. FOR REPAIRS ON THOSE AIRPLANES, DO A HIGH FREQUENCY EDDY CURRENT (HFEC) HOLE PROBE INSPECTION OF THE INITIAL FASTENER HOLES AT THE TIME OF REPAIR. IF NO DAMAGE IS EVIDENT, INSTALL THE APPROPRIATE REPAIR FASTENER AND ACCOMPLISH THE INITIAL INSPECTION AT THE FLIGHT CYCLES NOTED FROM TIME OF REPAIR (16,000 OR 29,000 FLIGHT CYCLES BASED ON T SKIN).

- J** THE INSPECTION THRESHOLD IS BASED ON FLIGHT CYCLES FROM TIME OF REPAIR FOR REPAIRS WITH NO INITIAL FASTENERS IN THE INSPECTION AREA EXCEPT THE TWO STRINGER FASTENERS (AT FORWARD AND AFT EDGE OF REPAIR).
- K** IF THE FASTENER HOLES INTERSECT A CHEM-MILLED STEP, BLEND THE CHEM-MILLED STEP AS GIVEN IN SRM 53-00-01, ALLOWABLE DAMAGE 1, DETAIL II. DO NOT MAKE THE BLEND DEEPER THAN THE DEPTH OF THE SKIN POCKET.
- L** INSTALL FASTENERS AT ALL REPAIR DOUBLER CORNERS.
- M** WHEN A BLIND FASTENER IS REPLACED WITH A SOLID FASTENER, THE SOLID FASTENER MUST BE A MINIMUM OF 1/32 INCH LARGER THAN THE NOMINAL SIZE OF THE BLIND FASTENER THAT HAS BEEN REPLACED. **F**
- N** REFER TO SRM 51-30-01, FIGURE 2/GENERAL FOR THE MOST AVAILABLE STANDARD ALUMINUM SHEET METAL GAGES.

FASTENER SYMBOLS

-  REFERENCE FASTENER LOCATIONS
-  REPAIR FASTENER LOCATIONS
-  INITIAL FASTENER LOCATIONS. INSTALL PROTRUDING HEAD TYPE AND SAME SIZE AS PRODUCTION, 1/32 INCH OVERSIZE IF NECESSARY. **F**

**Fuselage Skin - External Repair for Damage Between Stringers with Solid Fasteners - 757-SF
Figure 201 (Sheet 2 of 6)**

STRUCTURAL REPAIR MANUAL

REPAIR MATERIAL			
PART		QTY	MATERIAL
1	DOUBLER	1	SAME MATERIAL AND ONE STANDARD GAGE THICKER THAN THE THICKEST TRIMMED SKIN THICKNESS. MINIMUM DOUBLER GAGE IS 0.050 INCH. [F] [G] [N]

MATERIAL REQUIREMENTS FOR REPAIRS IN ZONES A AND B [D]
TABLE I

REPAIR DOUBLER THICKNESS LIMITATION FOR CATEGORY B REPAIRS	
MINIMUM SKIN GAGE COMMON TO ANY REPAIR FASTENER	MAXIMUM REPAIR DOUBLER GAGE [G]
0.040	0.063
0.045	0.063
0.050	0.071
0.056	0.080
0.063	0.090
0.071	0.100
0.080	0.110
0.090	0.125

TABLE II

INITIAL MINIMUM SKIN POCKET THICKNESS IN REPAIR AREA	FASTENERS [F] [M]	NUMBER OF ROWS (SEE DETAIL I)		SPACING (P)
		LONGITUDINAL	CIRCUMFERENTIAL	
0.040	BACR15FT5KE	3	3	0.63 TO 0.91
0.045	BACR15FT5KE	3	3	0.63 TO 0.94
0.050	BACR15FT5KE	3	3	0.63 TO 0.94
0.056	BACR15FT6KE	3	3	0.75 TO 1.13
0.063	BACR15FT6KE	3	3	0.75 TO 1.13
0.071	BACR15FT6KE	3	3	0.75 TO 1.13
0.080	BACR15FT7KE	3	3	0.87 TO 1.30
0.090	BACR15FT8KE	3	3	1.00 TO 1.50

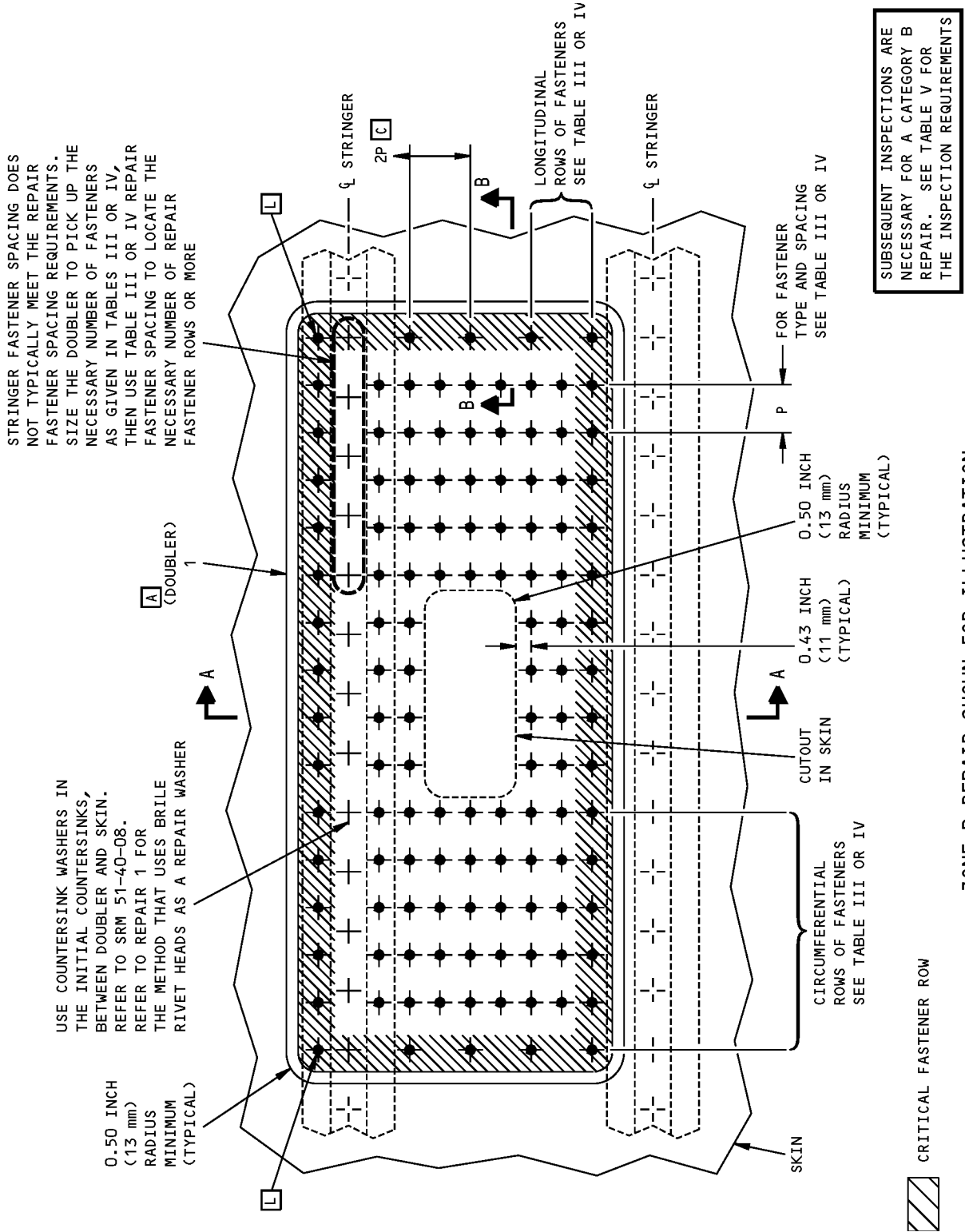
FASTENER REQUIREMENTS FOR REPAIRS IN ZONE A [D]
TABLE III

INITIAL MINIMUM SKIN POCKET THICKNESS IN REPAIR AREA	FASTENERS [F] [M]	NUMBER OF ROWS (SEE DETAIL I)		SPACING [C] (P)
		LONGITUDINAL	CIRCUMFERENTIAL	
0.040	BACR15FT5KE	3	5	0.63 TO 0.91
0.045	BACR15FT5KE	3	5	0.63 TO 0.94
0.050	BACR15FT5KE	3	5	0.63 TO 0.94
0.056	BACR15FT6KE	3	5	0.75 TO 1.13
0.063	BACR15FT6KE	3	5	0.75 TO 1.13
0.071	BACR15FT6KE	3	5	0.75 TO 1.13
0.080	BACR15FT7KE	3	5	0.87 TO 1.30
0.090	BACR15FT8KE	3	5	1.00 TO 1.50

FASTENER REQUIREMENTS FOR REPAIRS IN ZONE B [D]
TABLE IV

Fuselage Skin - External Repair for Damage Between Stringers with Solid Fasteners - 757-SF
Figure 201 (Sheet 3 of 6)

**757-200
STRUCTURAL REPAIR MANUAL**

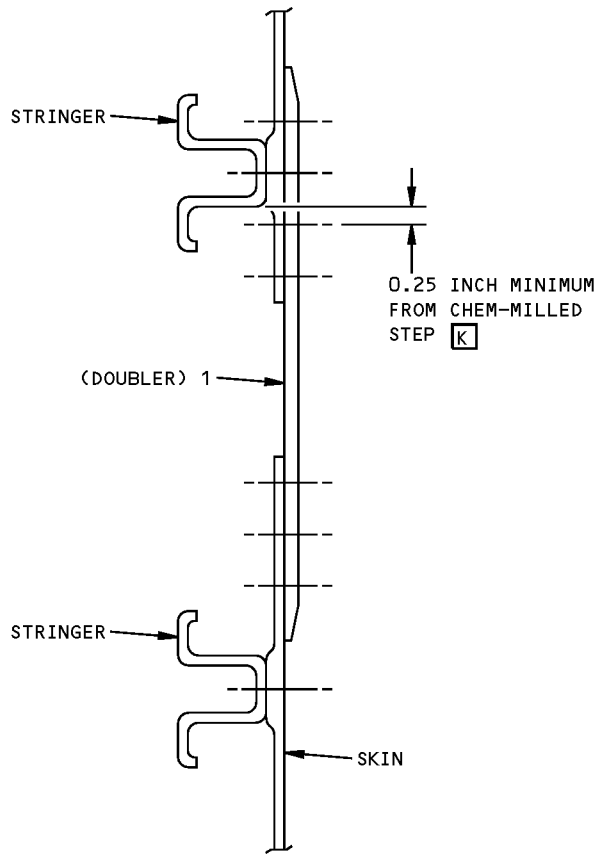


SUBSEQUENT INSPECTIONS ARE NECESSARY FOR A CATEGORY B REPAIR. SEE TABLE V FOR THE INSPECTION REQUIREMENTS

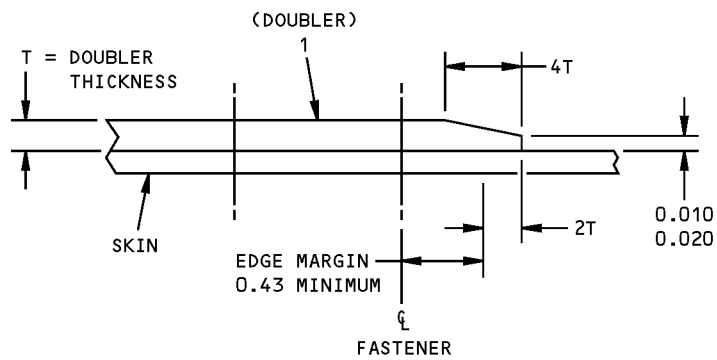
**ZONE B REPAIR SHOWN FOR ILLUSTRATION
DETAIL I**

**Fuselage Skin - External Repair for Damage Between Stringers with Solid Fasteners - 757-SF
Figure 201 (Sheet 4 of 6)**

**757-200
STRUCTURAL REPAIR MANUAL**



SECTION A-A



SECTION B-B

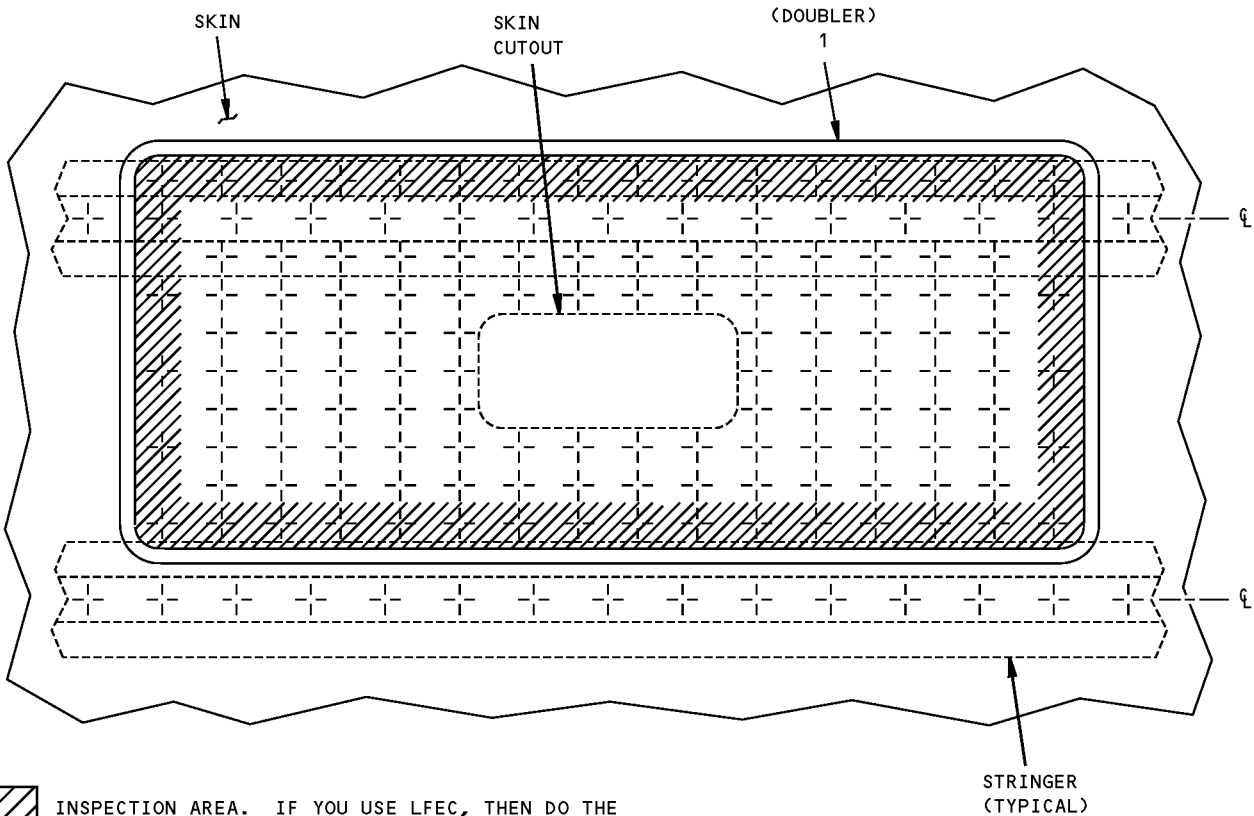
**Fuselage Skin - External Repair for Damage Between Stringers with Solid Fasteners - 757-SF
Figure 201 (Sheet 5 of 6)**


**757-200
STRUCTURAL REPAIR MANUAL**

CATEGORY B REPAIR INSPECTION REQUIREMENTS					
REPAIR ZONES	INSPECTION THRESHOLD (FLIGHT CYCLES)		REPEAT INSPECTION ALTERNATIVES		
	TOTAL FLIGHTS	FROM TIME OF REPAIR	METHOD	INTERVAL	REFERENCE
ZONE B [H]	25,000	SEE REPEAT INSPECTION INTERVALS	HIGH FREQUENCY EDDY CURRENT (HFEC)	6,000	NDT PART 6 51-00-01
ZONE A tSKIN ≤ 0.050 tSKIN ≥ 0.051	[I] 25,000 37,000	[J] 16,000 29,000	LOW FREQUENCY EDDY CURRENT (LFEC) [E]	3,000	NDT PART 6 53-00-06

NOTE: INSPECT THE SKIN AROUND THE FIRST ROW OF FASTENERS ALONG THE EDGE OF THE DOUBLER AS SHOWN IN DETAIL II. USE ONE OF THE TWO INSPECTION METHODS.

TABLE V



 INSPECTION AREA. IF YOU USE LFEC, THEN DO THE INSPECTION OF THE SKIN EXTERNALLY THROUGH THE DOUBLER. IF YOU USE HFEC, INSPECT THE SKIN INTERNALLY. HOWEVER, HFEC INSPECTION IS NOT NECESSARY AROUND THE FASTENERS WHERE THE SKIN IS UNDER THE STRINGER.

DETAIL II

**Fuselage Skin - External Repair for Damage Between Stringers with Solid Fasteners - 757-SF
Figure 201 (Sheet 6 of 6)**

**757-200
STRUCTURAL REPAIR MANUAL**

REPAIR 17 - FUSELAGE SKIN REPAIR NEAR THE PRIMARY STATIC PORTS - 757-SF

APPLICABILITY
THIS REPAIR IS APPLICABLE TO 757-SF AIRPLANES ONLY.

NOTES

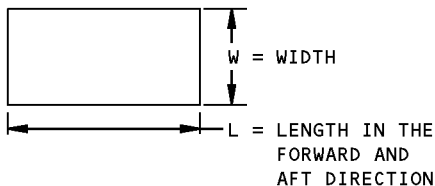
- REPAIRS DIFFER DEPENDING ON LOCATION OF DAMAGE. SEE DETAIL I FOR DEFINITIONS OF REPAIR ZONES.
- FOR SKIN REPAIRS NEAR AIR DATA SENSORS (OTHER THAN THE PRIMARY STATIC PORTS), REFER TO SRM 51-10-01, FIGURE 7/GENERAL.
- WHEN YOU USE THIS REPAIR REFER TO:
 - AMM 11-21-21 FOR PLACARDS AND MARKINGS
 - AMM 34-11-03 FOR REMOVAL AND INSTALLATION OF STATIC PORTS
 - AMM 51-21 FOR INTERIOR AND EXTERIOR FINISHES
 - SOPM 20-20-02 FOR PENETRANT INSPECTION METHODS
 - SRM 51-10-01 FOR AERODYNAMIC SMOOTHNESS REQUIREMENTS
 - SRM 51-10-02 FOR INSPECTION AND REMOVAL OF DAMAGE
 - SRM 51-20-01 FOR PROTECTIVE TREATMENT OF METAL
 - SRM 51-20-05 FOR SEALING OF FUSELAGE SKIN REPAIRS
 - SRM 51-40 FOR FASTENER CODE, INSTALLATION AND REMOVAL, HOLE SIZES AND EDGE MARGINS
 - SRM 51-40-08 FOR COUNTERSINK WASHERS.

REPAIR INSTRUCTIONS

1. Return all indented or projecting skin to contour.
2. Penetrant inspect surface for cracks. If cracks are found, stop drill to a diameter of 0.25 inch (6 mm), or remove damaged skin using a 0.50 inch (13 mm) minimum corner radius. A filler is necessary if damage is at a stringer location. See Fig. 217 for filler and surface treatment. **A**
3. For Zone 1 repairs, do the steps that follow:
 - A. Remove and discard static ports.
 - B. Increase the diameter of the initial static port hole for a 232N9104-1 washer.
 - C. Make the repair doubler and drill the fastener holes. See Detail VI for the countersink in the repair doubler at the static port.
4. Apply a chemical conversion coating to the repair parts and to the bare surfaces of the remaining skin. Refer to SRM 51-20-01.
5. Apply one layer of BMS 10-11, Type I primer and one layer of BMS 10-11, Type II enamel to the mating surfaces. Refer to SOPM 20-41-02.
6. Install the repair parts with BMS 5-95 sealant between the mating surfaces.
7. Install the fasteners. Do not use sealant to install the BACR15FV (Briles) rivet.
8. A bead of sealant will be squeezed out, around the repair, at the edges. Make the bead into a fillet. Add more sealant to make the fillet seal, if necessary.
9. Install the new static port assembly and microshave flush with the doubler to +0.003/-0.000 inch (+0.076 mm/-0.000 mm) (for Zone 1 repairs only).
10. Restore the surface finish. Refer to AMM 51-21.

A FOR ALL CUM LINE NUMBERS THAT ARE NOT 154 THRU 204: DO A DETAILED, INTERNAL VISUAL INSPECTION OF THE SKIN IN THE REPAIR AREA, SPECIALLY AT THE OUTERMOST FASTENER ROW OF THE DOUBLER. DO THE INSPECTION WHEN THE AIRFRAME HAS 37,500 FLIGHT CYCLES, AND DO THE INSPECTION AGAIN EVERY 12,000 FLIGHT CYCLES. **F**

FOR CUM LINE NUMBERS 154 THRU 204, AND ANY EXTERNAL REPAIR WHERE THE SKIN POCKET IS 0.040 INCH (1.02 mm) AT THE OUTER FASTENER ROW: DO AN EXTERNAL, LOW FREQUENCY, EDDY CURRENT (LFEC) INSPECTION OF THE SKIN THAT IS UNDER THE REPAIR DOUBLER. DO THE INSPECTION AT THE OUTERMOST FASTENER ROW OF THE DOUBLER. DO THE INSPECTION WHEN THE AIRFRAME HAS 37,500 FLIGHT CYCLES, AND DO THE INSPECTION AGAIN EVERY 3000 FLIGHT CYCLES. **F**



REPAIR DIMENSIONS

**Fuselage Skin Repair Near the Primary Static Ports - 757-SF
Figure 201 (Sheet 1 of 6)**

STRUCTURAL REPAIR MANUAL

NOTES (CONT)

B THE FOLLOWING RESTRICTIONS APPLY:

1. EXTERNAL REPAIRS ONLY
2. NO REPAIR EDGES WITHIN THIS ZONE (I.E. ANY REPAIR WHICH ENTERS THE ZONE MUST COVER AT LEAST THE ENTIRE ZONE)
3. REPAIRS COVERING THIS ZONE MUST HAVE $L \geq 2.2W$
4. NO TAPERED SHIMS MAY ENTER THIS ZONE.
5. IN ADDITION TO THE ABOVE LIMITS, THE FOLLOWING NOTE APPLIES:

AFTER INSTALLATION, THE SURFACE OF THE SKIN AND PORT FOR A DISTANCE 3 INCHES FORWARD AND AFT OF THE PORT CENTERLINE SHALL BE FLUSH WITHIN 0.010 INCH (0.025 mm) MAXIMUM, MEASURED AS THE CLEARANCE BETWEEN THIS SURFACE AND THE EDGE OF A 6-INCH (150 mm) STRAIGHTEDGE THAT IS PLACED HORIZONTALLY AGAINST THE SURFACE. AS AN ALTERNATIVE, YOU CAN USE THE AVERAGE MEASUREMENT PROCEDURE AS GIVEN IN AMM 51-10-00-6. FOR RVSM OPERATION, YOU MUST USE THE AVERAGE MEASUREMENT PROCEDURE AS GIVEN IN AMM 51-10-00-6. THE SKIN WAVINESS MUST BE LESS THAN THE LIMIT OF ± 0.010 INCH (± 0.25 mm) WHEN MEASURED WITH THIS AVERAGE MEASUREMENT PROCEDURE.

C THE FOLLOWING RESTRICTIONS APPLY:

1. ANY REPAIR WHICH ENTERS ZONE 2 MUST SPAN THE ENTIRE LENGTH OF THE ZONE
2. REPAIRS ENTERING THE ZONE MUST HAVE $L > W$
3. EXTERNAL REPAIRS ARE PERMITTED. REFER TO SRM 51-10-01, FIGURE 7/GENERAL, DETAIL VII FOR THE AERODYNAMIC SMOOTHNESS REQUIREMENTS
4. FLUSH REPAIRS ARE PERMITTED IF THE TAPERED SHIMS END AT LEAST 2 INCHES (50 mm) AWAY FROM THE BORDER WITH ZONE 1. TAPERED SHIMS MUST HAVE AT LEAST A 50:1 TAPER RATIO
5. FOR CUM LINE NUMBERS 154 THRU 204, ONLY EXTERNAL REPAIRS ARE PERMITTED.
6. USE FLUSH FASTENERS ONLY.

D THE FOLLOWING RESTRICTIONS APPLY:

1. EXTERNAL REPAIRS ARE PERMITTED
2. FLUSH REPAIRS ARE PERMITTED IF THE TAPERED SHIMS END AT LEAST 2 INCHES AWAY FROM ZONE 1. TAPERED SHIMS MUST HAVE AT LEAST A 50:1 TAPER RATIO
3. ALL INTERNAL (FLUSH) REPAIRS ARE CATEGORY A REPAIRS IF THE REPAIR DOUBLERS ARE LESS THAN OR EQUAL TO 17 INCHES IN LENGTH.
4. USE FLUSH FASTENERS ONLY.

E ALL RIVETS WITHIN A 3-INCH (76 mm) RADIUS OF THE STATIC PORT HOLE MUST BE FLUSH WITH THE DOUBLER, WITHIN 0.003 INCH (0.076 mm) MAXIMUM. MAKE THE FASTENER SPACING 2.0 TO 3.0 INCHES (50 mm TO 76 mm) IN THE CIRCUMFERENTIAL AND LONGITUDINAL DIRECTIONS.

F THIS REPAIR HAS FAA APPROVAL AS A PERMANENT CATEGORY B REPAIR, CONTINGENT ON ACCOMPLISHMENT OF THE INSPECTIONS AT THE INTERVALS CONTAINED HEREIN.

G FOR RVSM OPERATION, A MAXIMUM OF TWO EXTERNAL REPAIRS, OR TWO INTERNAL REPAIRS THAT EXTEND ACROSS A FRAME OR STRINGER, ARE PERMITTED IN THE AREA OF THE PRIMARY STATIC PORTS. THE TWO REPAIRS CAN BE ON ONE SIDE OF THE AIRPLANE, OR ONE REPAIR CAN BE ON EACH SIDE. THESE LIMITS ARE BASED ON MAINTAINING SATISFACTORY PERFORMANCE OF THE PRIMARY ALTIMETRY SYSTEM.

H BETWEEN THE DOUBLER AND THE SKIN USE COUNTERSINK WASHERS IN THE INITIAL COUNTERSINK HOLES. REFER TO SRM 51-40-08. ALTERNATIVELY, REFER TO SRM 53-00-01, REPAIR 1, TO USE THE BRILES RIVET HEAD AS A REPAIR WASHER.

FASTENER SYMBOLS

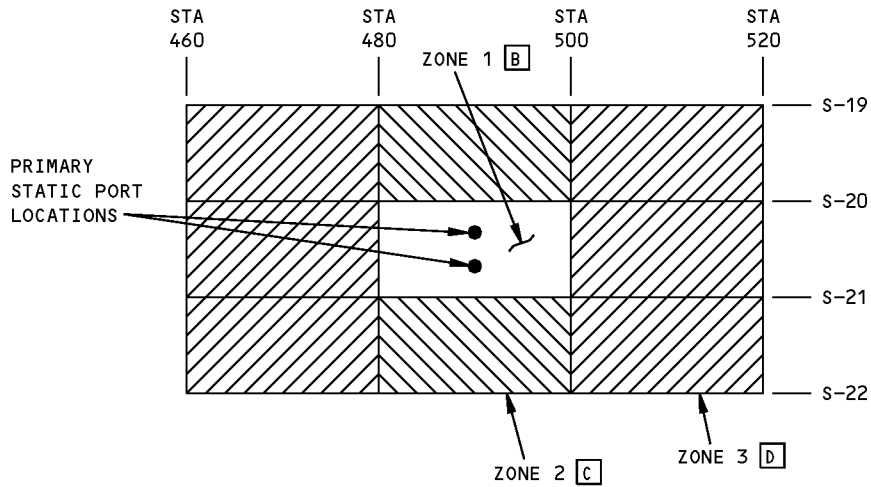
- + INITIAL FASTENER LOCATION.
- ✦ INITIAL FASTENER LOCATION. INSTALL BACR15FV6KE* BRILES, 120 DEGREE HEAD RIVET, SAME SPACING, TYPE AND DIAMETER AS THE INITIAL FASTENER.
- ⊕ REPAIR FASTENER LOCATION. BACR15FV6KE* BRILES, 120 DEGREE HEAD RIVET.

REPAIR MATERIAL			
	PART	QTY	MATERIAL
1	REPAIR DOUBLER	1	0.063 2024-T3 CLAD
2	WASHER	AS REQ'D	232N9104-1 WASHER AS REQUIRED FOR REINSTALLATION
3	WASHER	AS REQ'D	65-60419-3 WASHER AS REQUIRED FOR REINSTALLATION

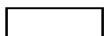


TABLE I

**Fuselage Skin Repair Near the Primary Static Ports - 757-SF
Figure 201 (Sheet 2 of 6)**

**757-200
STRUCTURAL REPAIR MANUAL**

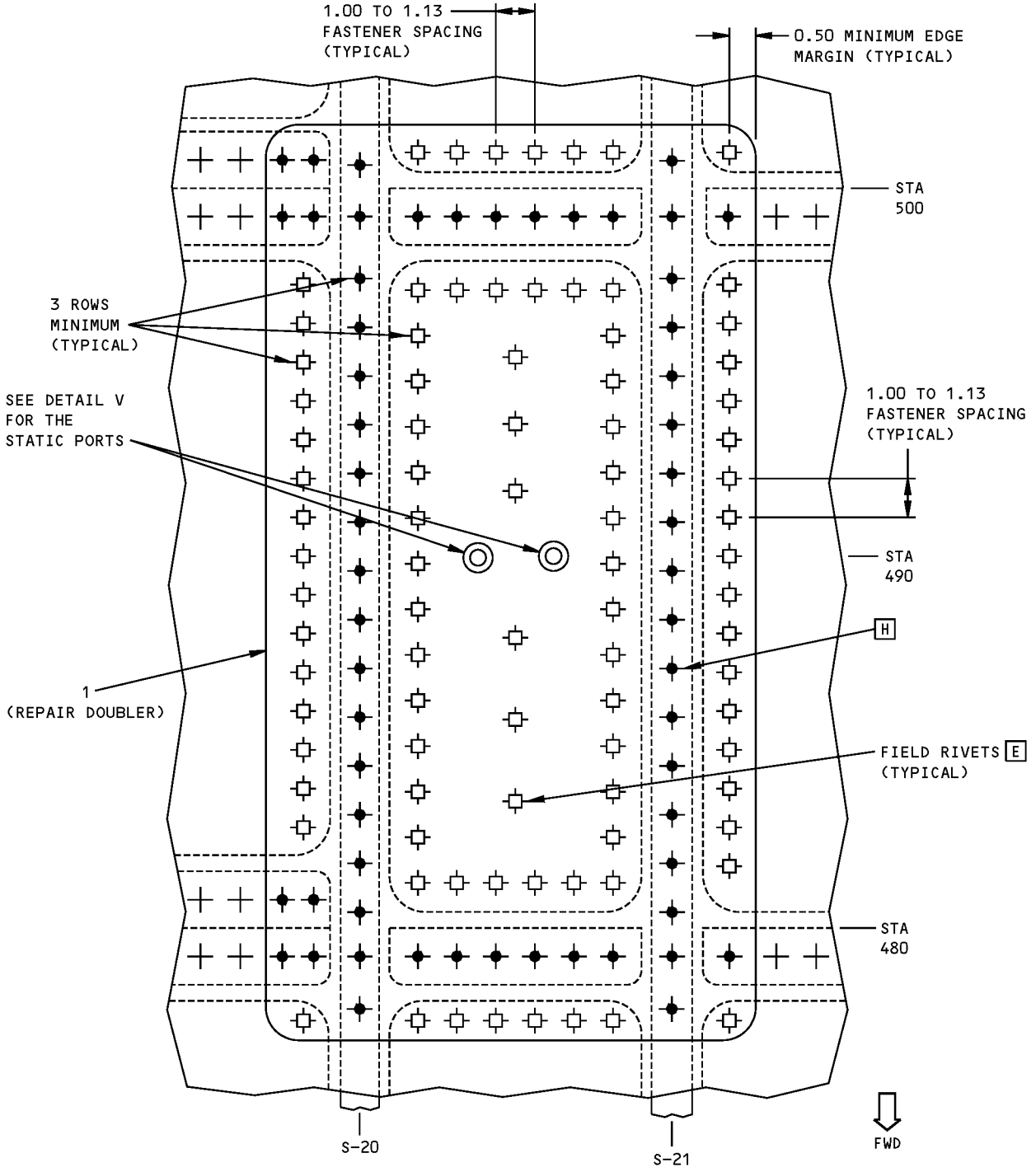


**REPAIR ZONES [F] [G]
DETAIL I**

-  REPAIR ZONE 1 [B] [E]
-  REPAIR ZONE 2 [C]
-  REPAIR ZONE 3 [D]

**Fuselage Skin Repair Near the Primary Static Ports - 757-SF
Figure 201 (Sheet 3 of 6)**

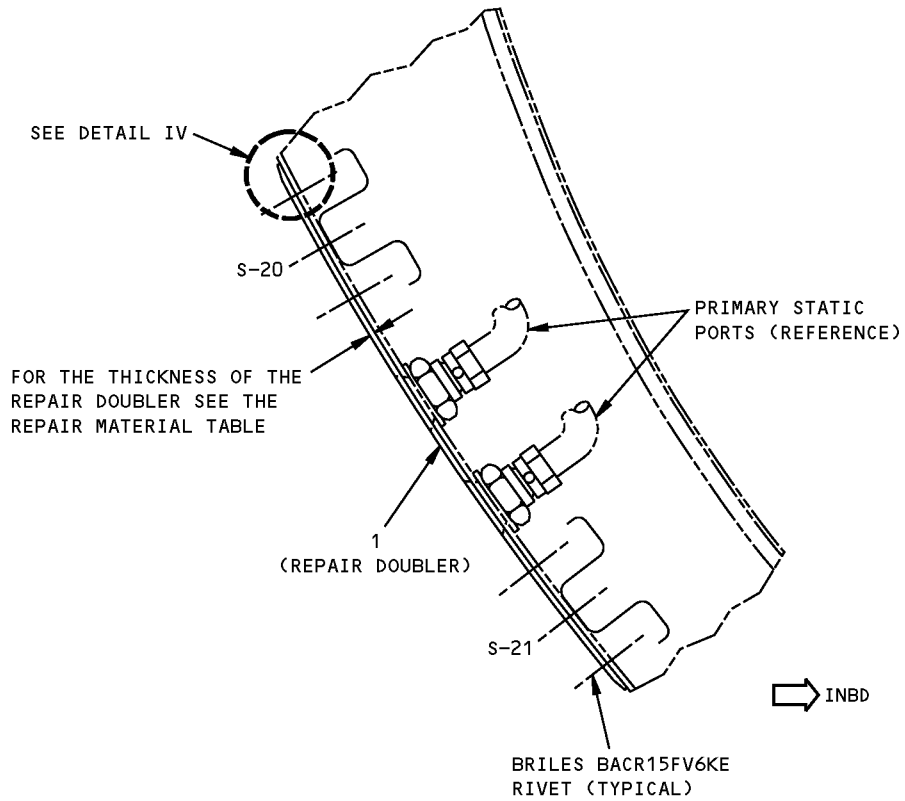
STRUCTURAL REPAIR MANUAL



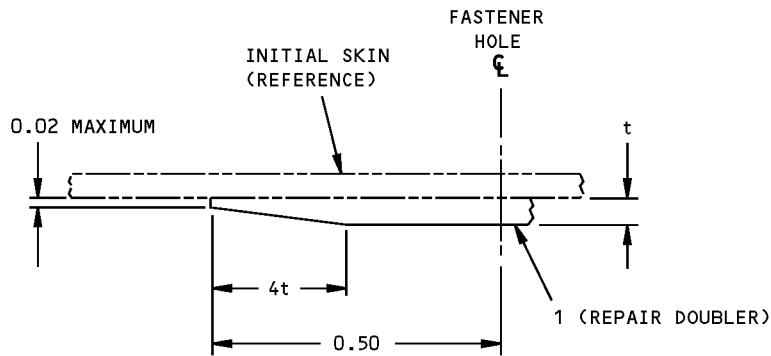
EXTERNAL SKIN REPAIR NEAR THE PRIMARY STATIC PORTS
 ZONE 1 REPAIR IS SHOWN
 DETAIL II

Fuselage Skin Repair Near the Primary Static Ports - 757-SF
Figure 201 (Sheet 4 of 6)

**757-200
STRUCTURAL REPAIR MANUAL**



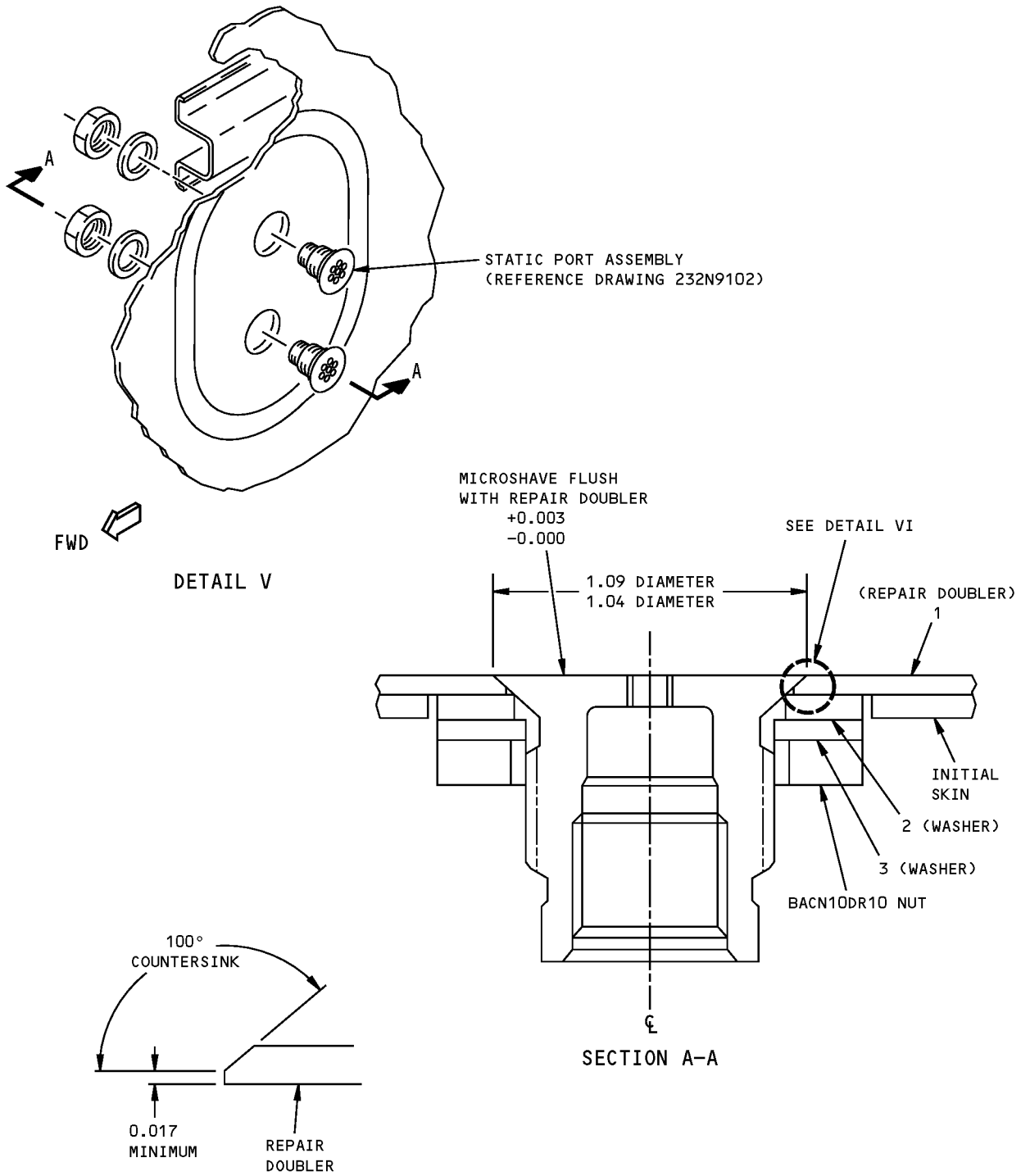
DETAIL III



**TYPICAL ALL EDGES
DETAIL IV**

**Fuselage Skin Repair Near the Primary Static Ports - 757-SF
Figure 201 (Sheet 5 of 6)**

**757-200
STRUCTURAL REPAIR MANUAL**

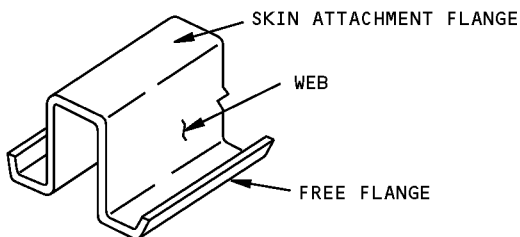


(ONLY THE REPAIR DOUBLER IS SHOWN)
DETAIL VI

**Fuselage Skin Repair Near the Primary Static Ports - 757-SF
Figure 201 (Sheet 6 of 6)**

**757-200
STRUCTURAL REPAIR MANUAL**

ALLOWABLE DAMAGE 1 - FUSELAGE STRINGERS



TYPICAL STRINGER SECTION

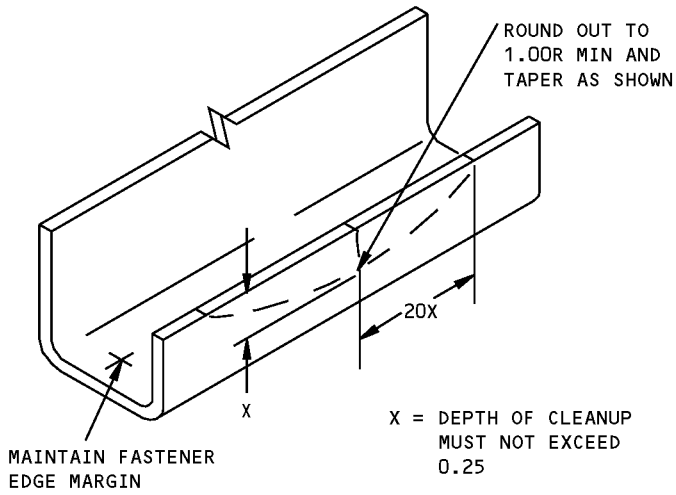
	CRACKS	NICKS GOUGES CORROSION	DENTS	HOLES
WEBS	A	B	D	C
SKIN ATTACHMENT FLANGES	A	B	D	NOT ALLOWED
FREE FLANGES	A	B	D	C

NOTES

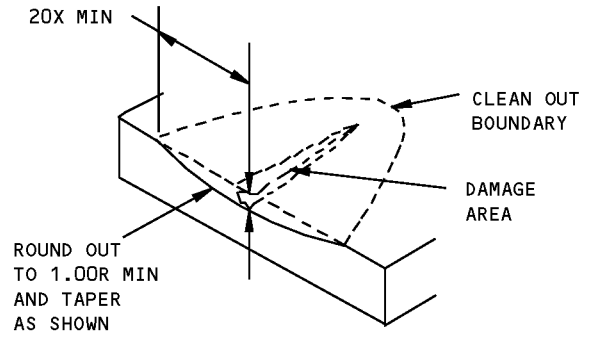
- THIS ALLOWABLE DAMAGE DATA IS APPLICABLE TO PASSENGER AIRPLANES ONLY.
 - REFINISH REWORKED AREAS PER 51-20 OF THE MAINTENANCE MANUAL.
 - DAMAGE MUST NOT EXCEED 20% OF THE CROSS-SECTIONAL AREA OF 1 STRINGER NOR MAY THE TOTAL CROSS-SECTIONAL AREA LOST IN ANY GROUP OF 4 ADJACENT STRINGERS EXCEED 20% OF THE TOTAL CROSS-SECTIONAL AREA OF THOSE 4 STRINGERS
- A** EDGE CRACKS MUST BE REMOVED AS SHOWN IN DETAIL I. ELSEWHERE CRACKS ARE NOT ALLOWED.
- B** EDGE DAMAGE MUST BE REWORKED AS SHOWN IN DETAIL I. ELSEWHERE DAMAGE MUST BE REMOVED AS SHOWN IN DETAIL II.
- C** HOLES ARE ALLOWED UP TO 0.25 INCH DIAMETER PROVIDED THAT THEY ARE NOT CLOSER THAN 4D TO ANY EXISTING HOLE OR OTHER DAMAGE AND THE HOLES ARE FILLED WITH 2117-T4 (PROCURED TEMPER) RIVETS INSTALLED WET WITH BMS 5-95 SEALANT.
- D** DENTS MUST BE SMOOTH AND FREE FROM CREASES, GOUGES, CRACKS AND SHOWING NO EVIDENCE OF PULLING OR LOOSE RIVETS. LIMITS ARE SHOWN IN DETAIL III.

**Fuselage Stringers Allowable Damage
Figure 101 (Sheet 1 of 2)**

**757-200
STRUCTURAL REPAIR MANUAL**

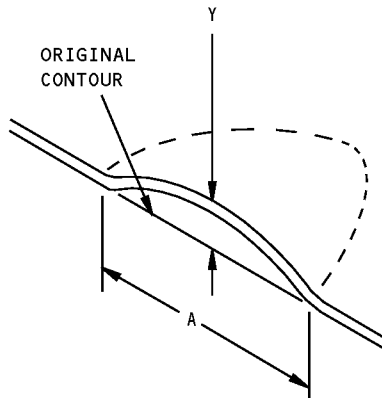


DETAIL I



X = DEPTH OF CLEANUP MUST NOT EXCEED 20% OF GAGE

DETAIL II



$\frac{A}{Y}$ MUST NOT BE LESS THAN 30

A = WIDTH OF MINOR AXIS OF DENT

Y = DEPTH OF DENT FROM CONTOUR

Y = 0.125 MAX

DETAIL III

**Fuselage Stringers Allowable Damage
Figure 101 (Sheet 2 of 2)**

STRUCTURAL REPAIR MANUAL

REPAIR 1 - FUSELAGE STRINGER REPAIR S-1 THRU S-30

APPLICABILITY I
THIS STRINGER SPLICE REPAIR HAS LIMITED APPLICABILITY BETWEEN S-4R TO S-4L AND FROM BS 740 THRU 880 F .

REPAIR INSTRUCTIONS

1. Cut and remove the damaged portion of stringer. Do not cut into skin. If skin is damaged see SRM 53-00-01.
2. Make repair parts per Detail II, III or IV.
3. Assemble the repair parts and drill the fastener holes.
4. Disassemble the repair parts.
5. Remove the nicks, scratches, gouges, burrs and sharp edges from the repair part and the seat track.
6. Apply a chemical conversion coating to the bare surfaces of the initial and repair parts. Refer to SRM 51-20-01.
7. Apply one layer of BMS 10-11, Type I primer to the bare surfaces of the initial and repair parts. Refer to SOPM 20-41-02.
8. Apply one layer of BMS 10-11, Type II enamel to the bare surfaces of the initial and repair parts. Refer to SOPM 20-41-02.
9. Install the repair parts making a faying surface seal with BMS 5-95 sealant. Install rivets **H**. See Table I for rivet type and number of rows required.
10. Restore original finish per AMM 51-21.

NOTES

- WHEN YOU USE THIS REPAIR REFER TO:
 - AMM 51-21 FOR DECORATIVE EXTERIOR FINISHES, CLEANING AND PAINTING
 - SOPM 20-41-02 FOR APPLICATION OF CHEMICAL AND SOLVENT RESISTANT FINISHES
 - SRM 51-10-02 FOR INSPECTION AND REMOVAL OF DAMAGE AND ZERO-TIMING PROCEDURE
 - SRM 51-20-01 FOR PROTECTIVE TREATMENT OF METALLIC AND GRAPHITE MATERIALS
 - SRM 51-20-05 FOR SEALING PROCEDURES AND ALTERNATE SEALANTS
 - SRM 51-40-02 FOR FASTENER INSTALLATION AND REMOVAL
 - SRM 51-40-03 FOR FASTENER SUBSTITUTIONS
 - SRM 51-40-05 FOR FASTENER HOLE SIZES
 - SRM 51-40-06 FOR FASTENER EDGE MARGINS

- A** USED IN SECTION 41 ONLY.
- B** USED IN SECTIONS 43,44,46 AND 48.
- C** SEE TABLE II FOR REPAIR SECTION NUMBER. FOR DIMENSIONS AND LOCATION OF TYPES I AND II SECTIONS, SEE TABLE III.
- D** USE WHEN REQUIRED. GAGE TO SUIT CONDITIONS OF NESTING FIT. INSTALL SHIM IF GAP EXCEEDS 0.006 INCH (0.152 mm) BEFORE INSTALLATION OF FASTENER. SHIM THICKNESS MUST NOT EXCEED 20% OF SHIM THICKNESS OF FASTENER DIAMETER MAXIMUM.
- E** IF ORIGINAL FASTENER HOLE IS DAMAGED, AND IF DAMAGE CAN BE REPAIRED BY OVERSIZING, AN OVERSIZED FASTENER UP TO 1/32 IS PERMITTED. TO AVOID KNIFE-EDGING OF THE SKIN, DO NOT COUNTERSINK DEEPER THAN 70% OF THE SKIN THICKNESS.
- F** REFER TO DETAIL I FOR RESTRICTIONS ON STRINGER SPLICE USE.
- G** SPARES KIT PART NUMBER. ALL REPAIR SECTIONS ARE IN 5.0 FT (152 cm) LENGTHS.
- H** BACR15FV RIVETS SHOULD NEVER BE INSTALLED WITH SEALANT.
NOTE: IT IS NOT NECESSARY TO INSTALL THE OTHER RIVETS WITH SEALANT.
- I** FOR PASSENGER AIRPLANES ONLY.

FASTENER SYMBOLS

- + ORIGINAL FASTENER
- ◆ REPAIR FASTENER

**Fuselage Stringer Repair S-1 thru S-30
Figure 201 (Sheet 1 of 9)**



**757-200
STRUCTURAL REPAIR MANUAL**

REPAIR MATERIAL			
PART		QTY	MATERIAL
1	HAT SECTION	1	7075-T6 [C]
2	FILLER	1	CLAD 7075-T6, SAME GAGE AND TYPE ORIGINAL STRINGER
3	SHIM [D]	AS REQ'D	7075-T6
4	CHANNEL	1	7075-T6 [C]
5	ANGLE	2	7075-T6 [C]
6	CHANNEL	1	7075-T6 [C]
7	ANGLE	2	7075-T6 [C]

DETAIL NO.	ORIGINAL SECTION GAGE	SKIN-TO-STRINGER REPAIR FASTENERS	ALL OTHER REPAIR FASTENERS
		TYPE [E]	TYPE
II AND III	0.032 THRU 0.063	BACR15CE()D [A] BACR15FV()KE [B] [H]	BACR15FT6D
	0.064 THRU 0.090	BACR15CE()D [A] BACR15FV()KE [B] [H]	BACR15FT8D
IV	0.091 THRU 0.136	BACR15CE()D [A] BACR15FV()KE [B] [H]	BACR15FT8D

TABLE I

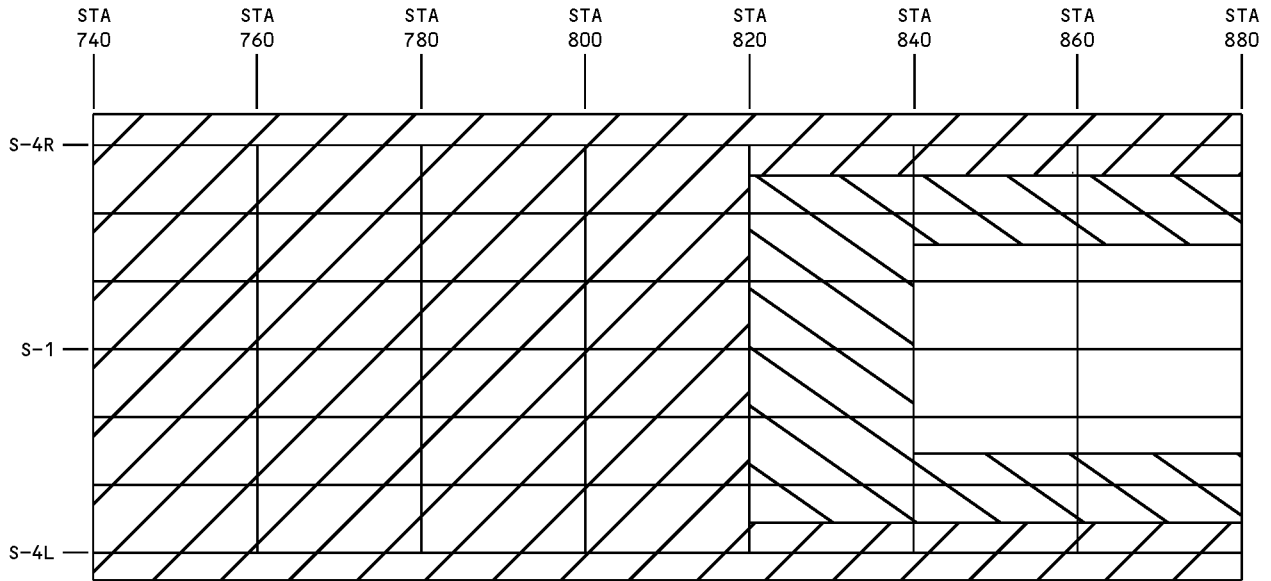
**Fuselage Stringer Repair S-1 thru S-30
Figure 201 (Sheet 2 of 9)**

D634N201

53-00-03

REPAIR 1
Page 202
Jan 20/2005

**757-200
STRUCTURAL REPAIR MANUAL**



**RESTRICTIONS ON STRINGER SPLICE USE
DETAIL I**



ZONE A

NO MORE THAN 1 SPLICE ALLOWED IN THIS AREA AND IF ONE SPLICE IS IN THIS AREA NO SPLICES ARE ALLOWED IN ZONES B AND C.



ZONE B

NO MORE THAN 2 SPLICES ALLOWED IN THIS AREA AND IF THERE ARE 2 SPLICES IN THIS AREA NO ADDITIONAL SPLICES ARE ALLOWED IN ZONE C (ONE SPLICE IN ZONE B AND ONE SPLICE IN ZONE C ARE PERMITTED)



ZONE C

NO MORE THAN 5 SPLICES ALLOWED IN ZONE C

**Fuselage Stringer Repair S-1 thru S-30
Figure 201 (Sheet 3 of 9)**



**757-200
STRUCTURAL REPAIR MANUAL**

ORIGINAL SECTION GAGE	ORIGINAL SECTION	REPAIR SECTION (REFER TO DETAIL I FOR STRINGER SPLICE RESTRICTONS)		
		DETAIL II	DETAIL III	DETAIL IV
0.032	TYPE I	BAC1498-200 OR 654N0010-124 [G]		
	TYPE II	BAC1498-232 OR 654N0010-129 [G]		
0.036	TYPE I	BAC1498-201 OR 654N0010-125 [G]		
	TYPE II	BAC1498-233 OR 654N0010-130 [G]		
0.040	TYPE I	BAC1498-202 OR 654N0010-126 [G]		
	TYPE II	BAC1498-234 OR 654N0010-131 [G]		
0.050	TYPE I	BAC1498-203 OR 654N0010-127 [G]		
	TYPE II	BAC1498-235 OR 654N0010-132 [G]		
0.056	TYPE I	BAC1498-203 OR 654N0010-127 [G]		
	TYPE II	BAC1498-235 OR 654N0010-132 [G]		
0.063	TYPE I	BAC1498-203 OR 654N0010-127 [G]		
	TYPE II	BAC1498-235 OR 654N0010-132 [G]		
0.071	TYPE I	BAC1498-204 OR 654N0010-128 [G]		
	TYPE II		BAC1498-236 OR 654N0010-133 [G]	
0.074	TYPE I	BAC1498-204 OR 654N0010-128 [G]		
	TYPE II		BAC1498-236 OR 654N0010-133 [G]	
0.080	TYPE I	BAC1498-204 OR 654N0010-128 [G]		
	TYPE II		BAC1498-236 OR 654N0010-133 [G]	
0.084	TYPE I	BAC1498-204 OR 654N0010-128 [G]		
	TYPE II		BAC1498-236 OR 654N0010-133 [G]	
0.090	TYPE I	BAC1498-204 OR 654N0010-128 [G]		
	TYPE II		BAC1498-236 OR 654N0010-133 [G]	

TABLE II

**Fuselage Stringer Repair S-1 thru S-30
Figure 201 (Sheet 4 of 9)**

D634N201

53-00-03

REPAIR 1
Page 204
Jan 20/2005



**757-200
STRUCTURAL REPAIR MANUAL**

ORIGINAL SECTION GAGE	ORIGINAL SECTION	REPAIR SECTION (REFER TO DETAIL I FOR STRINGER SPLICE RESTRICTONS)		
		DETAIL II	DETAIL III	DETAIL IV
0.091 THRU 0.120	TYPE I			BAC1493-782 OR 654N0010-134 <input type="checkbox"/> G BAC1493-785 OR 654N0010-137 <input type="checkbox"/> G BAC1493-792 OR 654N0010-144 <input type="checkbox"/> G BAC1493-793 OR 654N0010-145 <input type="checkbox"/> G
	TYPE II			BAC1493-784 OR 654N0010-136 <input type="checkbox"/> G BAC1493-786 OR 654N0010-138 <input type="checkbox"/> G BAC1493-788 OR 654N0010-140 <input type="checkbox"/> G BAC1493-790 OR 654N0010-142 <input type="checkbox"/> G
0.121 THRU 0.140	TYPE II			BAC1493-783 OR 654N0010-135 <input type="checkbox"/> G BAC1493-787 OR 654N0010-139 <input type="checkbox"/> G BAC1493-789 OR 654N0010-141 <input type="checkbox"/> G BAC1493-791 OR 654N0010-143 <input type="checkbox"/> G

TABLE II (CONTINUED)

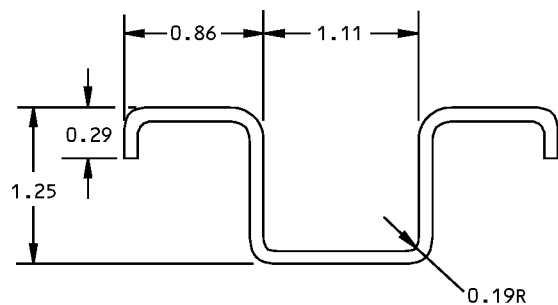
**Fuselage Stringer Repair S-1 thru S-30
Figure 201 (Sheet 5 of 9)**

D634N201

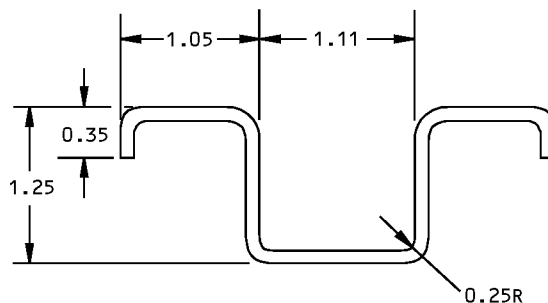
53-00-03

REPAIR 1
Page 205
Jan 20/2005

**757-200
STRUCTURAL REPAIR MANUAL**



TYPE I



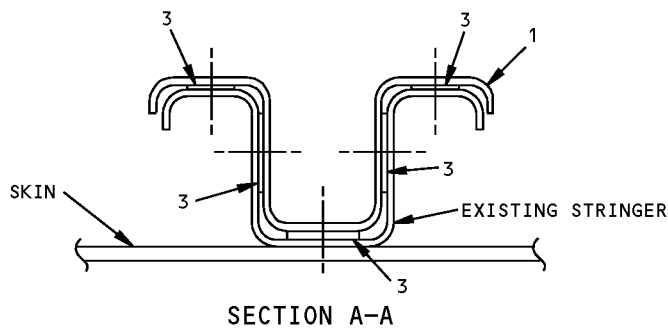
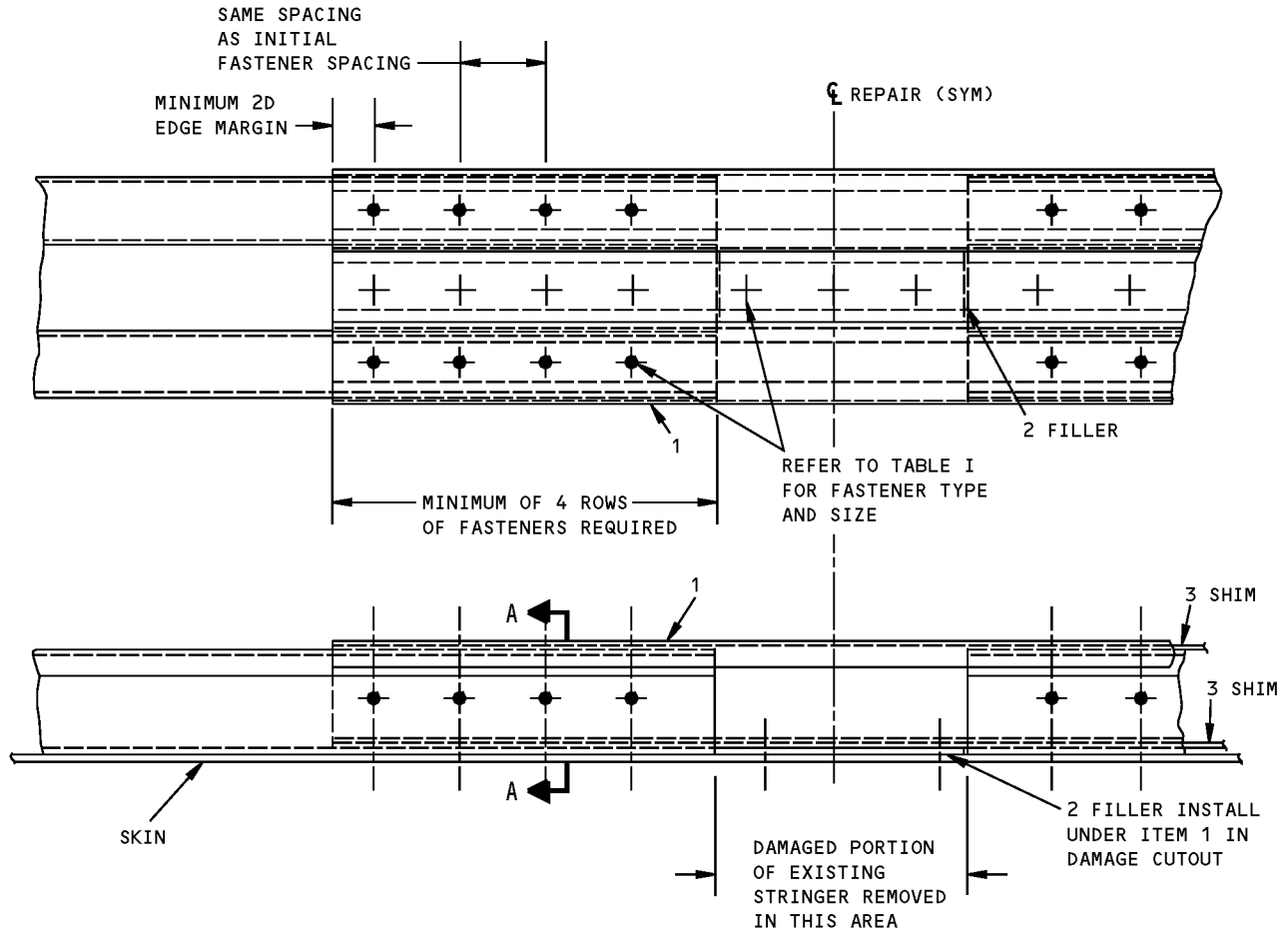
TYPE II

TYPE	LOCATION
I	STA 440 THRU STA 900, S-14R THRU S-14L (LOWER LOBE) STA 1180 THRU STA 1720, S-14R THRU S-14L (LOWER LOBE) STA 440 THRU STA 660, S-10L THRU S-10R (UPPER LOBE) STA 1680 THRU STA 1720, S-11
II	STA 660 THRU STA 1720, S-10L THRU S-10R (UPPER LOBE) STA 1180 THRU STA 1460, S-27 & S-28 STA 1400 THRU STA 1460, S-29 STA 660 THRU STA 900, S-27

TABLE III

**Fuselage Stringer Repair S-1 thru S-30
Figure 201 (Sheet 6 of 9)**

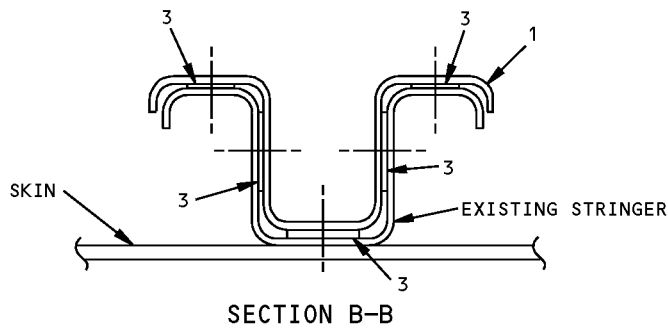
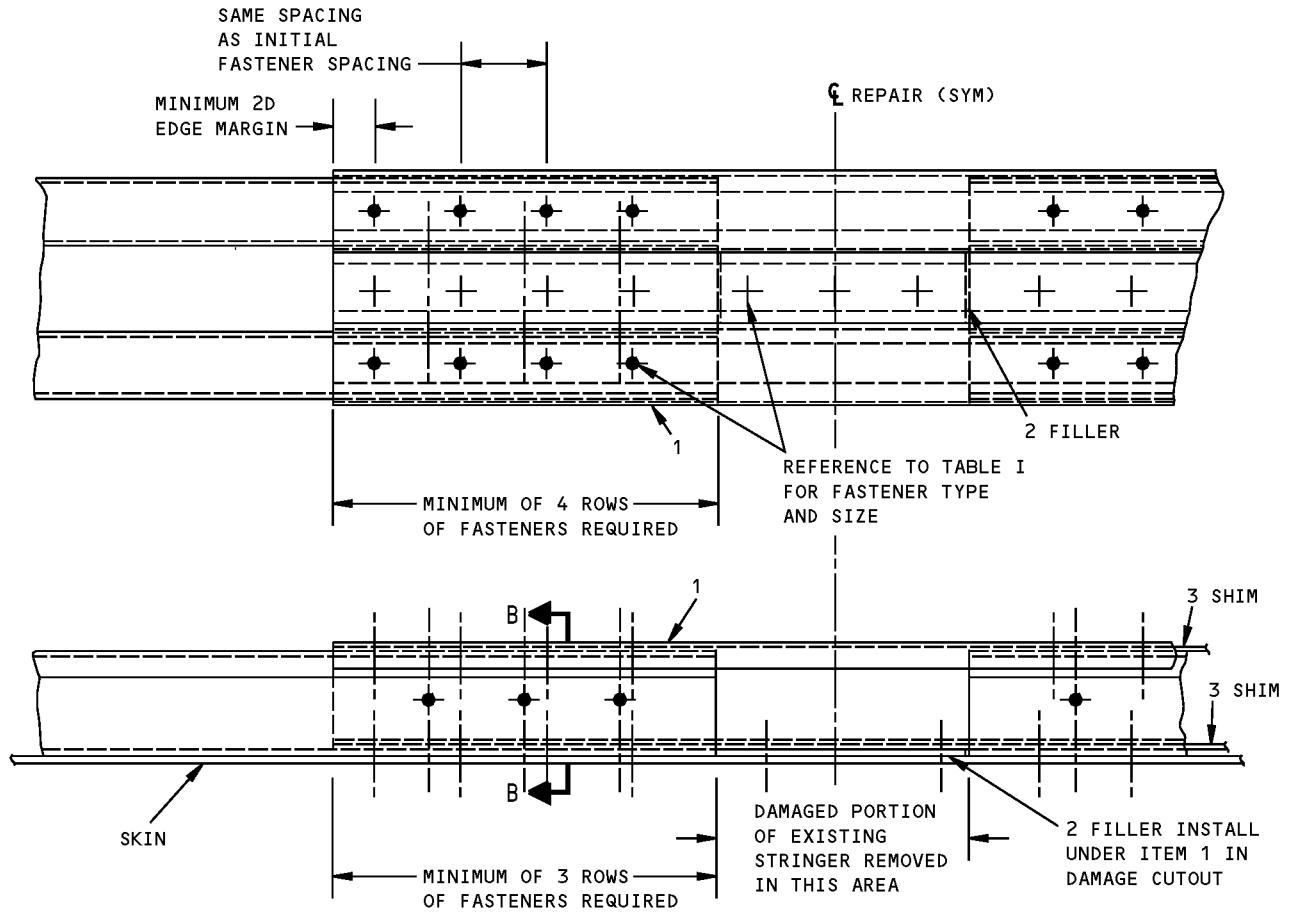
**757-200
STRUCTURAL REPAIR MANUAL**



FOR TYPE I STRINGERS WITH A GAGE OF 0.090 OR OR LESS
AND FOR TYPE II STRINGERS WITH A GAGE OF 0.063 OR LESS
DETAIL II

**Fuselage Stringer Repair S-1 thru S-30
Figure 201 (Sheet 7 of 9)**

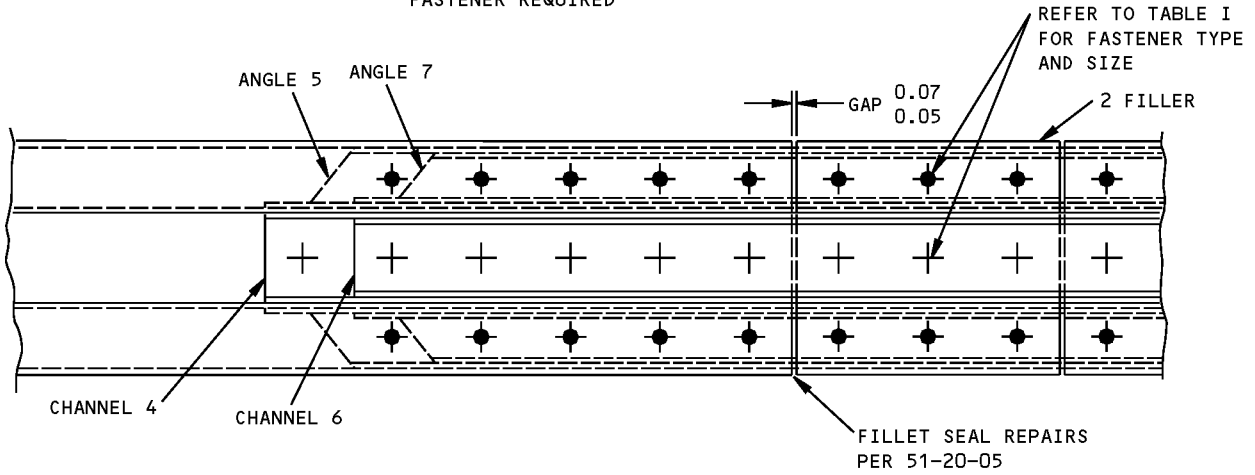
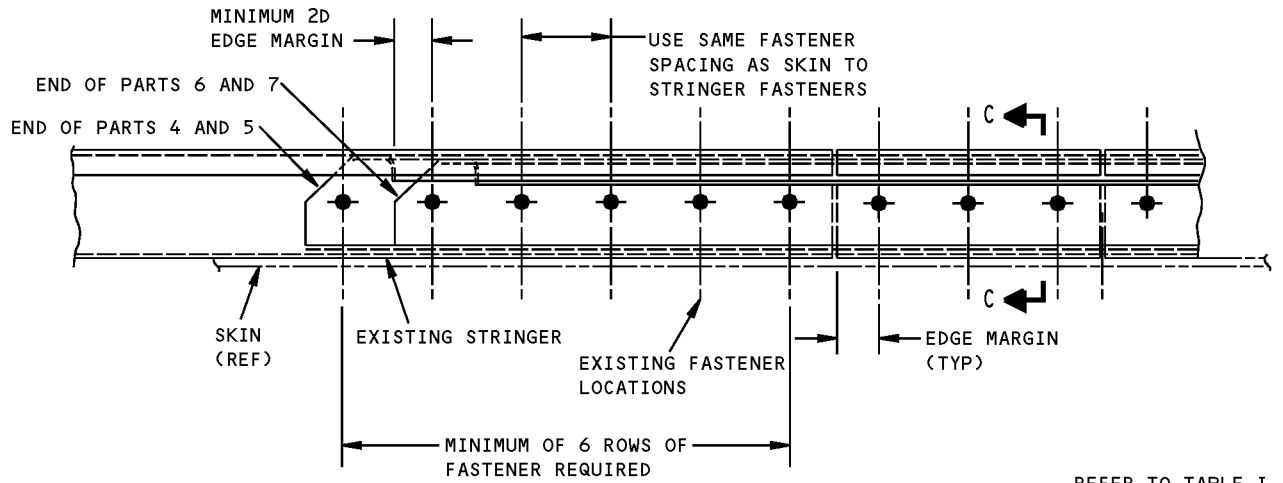
**757-200
STRUCTURAL REPAIR MANUAL**



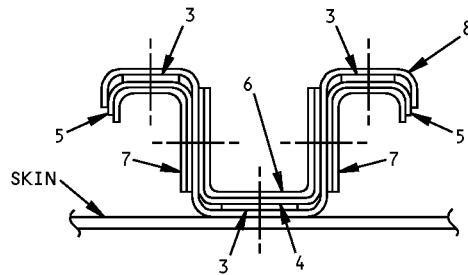
FOR TYPE II STRINGERS WITH A GAGE BETWEEN 0.064 TO 0.090
DETAIL III

**Fuselage Stringer Repair S-1 thru S-30
Figure 201 (Sheet 8 of 9)**

**757-200
STRUCTURAL REPAIR MANUAL**



TOP VIEW



SECTION C-C

FOR TYPE I OR II STRINGERS WITH GAGE GREATER THAN 0.090
DETAIL IV

**Fuselage Stringer Repair S-1 thru S-30
Figure 201 (Sheet 9 of 9)**

STRUCTURAL REPAIR MANUAL

REPAIR 2 - FUSELAGE STRINGER REPAIR S-1 THRU S-30 - 757-SF

APPLICABILITY
THIS REPAIR IS APPLICABLE TO 757-SF AIRPLANES ONLY.

REPAIR INSTRUCTIONS

1. Cut and remove the damaged portion of stringer. Do not cut into skin. If skin is damaged see SRM 53-00-01.
2. Make repair parts per Detail I, II or III.
3. Assemble the repair parts and drill the fastener holes.
4. Disassemble the repair parts.
5. Remove the nicks, scratches, gouges, burrs and sharp edges from the repair part and the seat track.
6. Apply a chemical conversion coating to the bare surfaces of the initial and repair parts. Refer to SRM 51-20-01.
7. Apply one layer of BMS 10-11, Type I primer to the bare surfaces of the initial and repair parts. Refer to SOPM 20-41-02.
8. Apply one layer of BMS 10-11, Type II enamel to the bare surfaces of the initial and repair parts. Refer to SOPM 20-41-02.
9. Install the repair parts making a faying surface seal with BMS 5-95 sealant. Install rivets **E**. See Table I for rivet type and number of rows required.
10. Restore initial finish in accordance with AMM 51-21.

NOTES

- THIS IS A CATEGORY A REPAIR FOR 757-SF AIRPLANES. THE INSPECTIONS GIVEN IN THE MAINTENANCE PLANNING DATA (MPD) ARE SUFFICIENT TO MAINTAIN THE DAMAGE TOLERANCE OF THE INITIAL STRUCTURE WITH THIS REPAIR INSTALLED. REFER TO SRM 51-00-06 FOR REPAIR CATEGORIES AND DEFINITIONS.

- WHEN YOU USE THIS REPAIR REFER TO:
 - AMM 51-21 FOR DECORATIVE EXTERIOR FINISHES, CLEANING AND PAINTING
 - SOPM 20-41-02 FOR APPLICATION OF CHEMICAL AND SOLVENT RESISTANT FINISHES
 - SRM 51-10-02 FOR INSPECTION AND REMOVAL OF DAMAGE AND ZERO-TIMING PROCEDURE
 - SRM 51-20-01 FOR PROTECTIVE TREATMENT OF METALLIC AND GRAPHITE MATERIALS
 - SRM 51-20-05 FOR SEALING PROCEDURES AND ALTERNATE SEALANTS
 - SRM 51-40-02 FOR FASTENER INSTALLATION AND REMOVAL
 - SRM 51-40-03 FOR FASTENER SUBSTITUTIONS
 - SRM 51-40-05 FOR FASTENER HOLE SIZES
 - SRM 51-40-06 FOR FASTENER EDGE MARGINS

- A** SEE TABLE II FOR REPAIR SECTION NUMBER. FOR DIMENSIONS AND LOCATION OF TYPES I AND II SECTIONS, SEE TABLE III.
 - B** USE WHEN REQUIRED. GAGE TO SUIT CONDITIONS OF NESTING FIT. INSTALL SHIM IF GAP EXCEEDS 0.006 INCH BEFORE INSTALLATION OF FASTENER. SHIM THICKNESS MUST NOT EXCEED 20% OF SHIM THICKNESS OF FASTENER DIAMETER MAXIMUM.
 - C** IF INITIAL FASTENER HOLE IS DAMAGED, AND IF DAMAGE CAN BE REPAIRED BY OVERSIZING, AN OVERSIZED FASTENER UP TO 1/32 IS PERMITTED. TO AVOID KNIFE-EDGING OF THE SKIN, DO NOT COUNTERSINK DEEPER THAN 70% OF THE SKIN THICKNESS.
 - D** SPARES KIT PART NUMBER. ALL REPAIR SECTIONS ARE IN 5.0 FT LENGTHS.
 - E** BACR15FV RIVETS SHOULD NEVER BE INSTALLED WITH SEALANT.
- NOTE:** IT IS NOT NECESSARY TO INSTALL THE OTHER RIVETS WITH SEALANT.

FASTENER SYMBOLS

- + INITIAL FASTENER
- ◆ REPAIR FASTENER

**Fuselage Stringer Repair S-1 thru S-30 - 757-SF
Figure 201 (Sheet 1 of 8)**



**757-200
STRUCTURAL REPAIR MANUAL**

REPAIR MATERIAL			
PART		QTY	MATERIAL
1	HAT SECTION	1	7075-T6 [A]
2	FILLER	1	CLAD 7075-T6, SAME GAGE AND TYPE INITIAL STRINGER
3	SHIM [B]	AS REQ'D	7075-T6
4	CHANNEL	1	7075-T6 [A]
5	ANGLE	2	7075-T6 [A]
6	CHANNEL	1	7075-T6 [A]
7	ANGLE	2	7075-T6 [A]

DETAIL NO.	INITIAL SECTION GAGE	SKIN-TO-STRINGER REPAIR FASTENERS	ALL OTHER REPAIR FASTENERS
		TYPE [C]	TYPE
I AND II	0.032 THRU 0.063	BACR15FV()KE [E]	BACR15FT6D
	0.064 THRU 0.090	BACR15FV()KE [E]	BACR15FT8D
III	0.091 THRU 0.136	BACR15FV()KE [E]	BACR15FT8D

TABLE I

**Fuselage Stringer Repair S-1 thru S-30 - 757-SF
Figure 201 (Sheet 2 of 8)**

D634N201

53-00-03

REPAIR 2
Page 202
Jan 20/2005



**757-200
STRUCTURAL REPAIR MANUAL**

INITIAL SECTION GAGE	INITIAL SECTION	REPAIR SECTION		
		DETAIL I	DETAIL II	DETAIL III
0.032	TYPE I	BAC1498-200 OR 654N0010-124 <input type="checkbox"/>		
	TYPE II	BAC1498-232 OR 654N0010-129 <input type="checkbox"/>		
0.036	TYPE I	BAC1498-201 OR 654N0010-125 <input type="checkbox"/>		
	TYPE II	BAC1498-233 OR 654N0010-130 <input type="checkbox"/>		
0.040	TYPE I	BAC1498-202 OR 654N0010-126 <input type="checkbox"/>		
	TYPE II	BAC1498-234 OR 654N0010-131 <input type="checkbox"/>		
0.050	TYPE I	BAC1498-203 OR 654N0010-127 <input type="checkbox"/>		
	TYPE II	BAC1498-235 OR 654N0010-132 <input type="checkbox"/>		
0.056	TYPE I	BAC1498-203 OR 654N0010-127 <input type="checkbox"/>		
	TYPE II	BAC1498-235 OR 654N0010-132 <input type="checkbox"/>		
0.063	TYPE I	BAC1498-203 OR 654N0010-127 <input type="checkbox"/>		
	TYPE II	BAC1498-235 OR 654N0010-132 <input type="checkbox"/>		
0.071	TYPE I	BAC1498-204 OR 654N0010-128 <input type="checkbox"/>		
	TYPE II		BAC1498-236 OR 654N0010-133 <input type="checkbox"/>	
0.074	TYPE I	BAC1498-204 OR 654N0010-128 <input type="checkbox"/>		
	TYPE II		BAC1498-236 OR 654N0010-133 <input type="checkbox"/>	
0.080	TYPE I	BAC1498-204 OR 654N0010-128 <input type="checkbox"/>		
	TYPE II		BAC1498-236 OR 654N0010-133 <input type="checkbox"/>	
0.084	TYPE I	BAC1498-204 OR 654N0010-128 <input type="checkbox"/>		
	TYPE II		BAC1498-236 OR 654N0010-133 <input type="checkbox"/>	
0.090	TYPE I	BAC1498-204 OR 654N0010-128 <input type="checkbox"/>		
	TYPE II		BAC1498-236 OR 654N0010-133 <input type="checkbox"/>	

TABLE II

**Fuselage Stringer Repair S-1 thru S-30 - 757-SF
Figure 201 (Sheet 3 of 8)**

D634N201

53-00-03

REPAIR 2
Page 203
Jan 20/2005



**757-200
STRUCTURAL REPAIR MANUAL**

INITIAL SECTION GAGE	INITIAL SECTION	REPAIR SECTION		
		DETAIL I	DETAIL II	DETAIL III
0.091 THRU 0.120	TYPE I			BAC1493-782 OR 654N0010-134 <input type="checkbox"/> D BAC1493-785 OR 654N0010-137 <input type="checkbox"/> D BAC1493-792 OR 654N0010-144 <input type="checkbox"/> D BAC1493-793 OR 654N0010-145 <input type="checkbox"/> D
	TYPE II			BAC1493-784 OR 654N0010-136 <input type="checkbox"/> D BAC1493-786 OR 654N0010-138 <input type="checkbox"/> D BAC1493-788 OR 654N0010-140 <input type="checkbox"/> D BAC1493-790 OR 654N0010-142 <input type="checkbox"/> D
0.121 THRU 0.140	TYPE II			BAC1493-783 OR 654N0010-135 <input type="checkbox"/> D BAC1493-787 OR 654N0010-139 <input type="checkbox"/> D BAC1493-789 OR 654N0010-141 <input type="checkbox"/> D BAC1493-791 OR 654N0010-143 <input type="checkbox"/> D

TABLE II (CONTINUED)

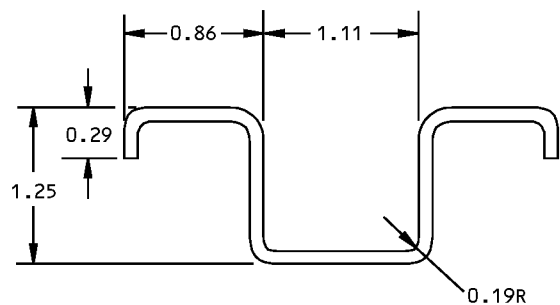
**Fuselage Stringer Repair S-1 thru S-30 - 757-SF
Figure 201 (Sheet 4 of 8)**

D634N201

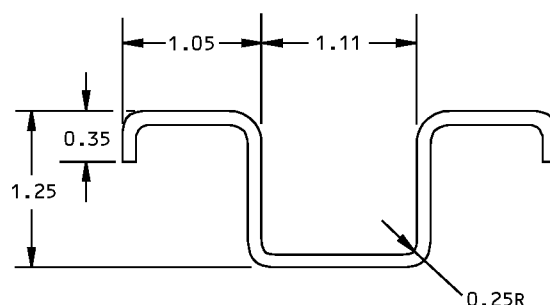
53-00-03

REPAIR 2
Page 204
Jan 20/2005

**757-200
STRUCTURAL REPAIR MANUAL**



TYPE I



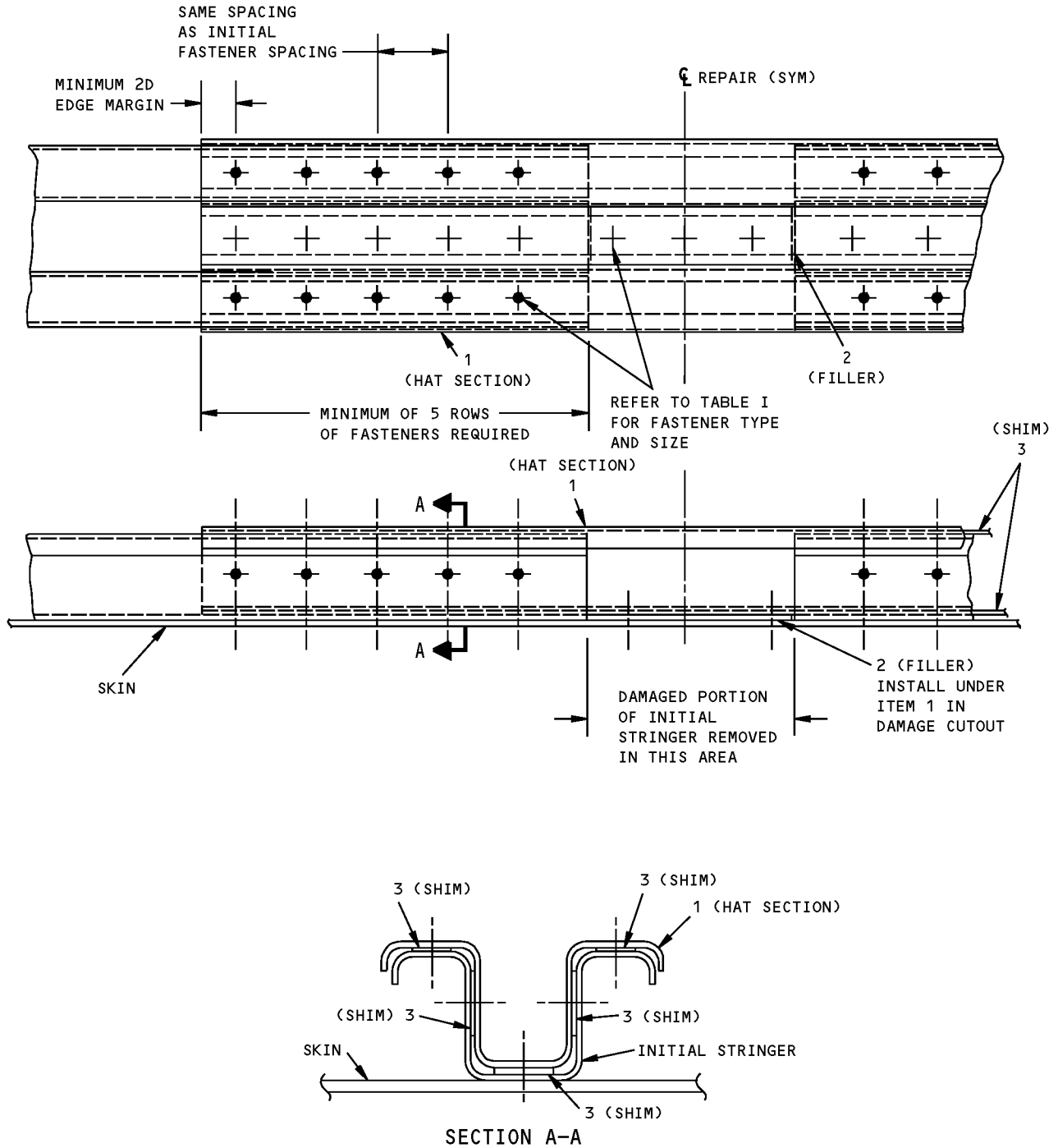
TYPE II

TYPE	LOCATION
I	STA 440 THRU STA 900, S-14R THRU S-14L (LOWER LOBE) STA 1180 THRU STA 1720, S-14R THRU S-14L (LOWER LOBE) STA 440 THRU STA 660, S-10L THRU S-10R (UPPER LOBE) STA 1680 THRU STA 1720, S-11
II	STA 660 THRU STA 1720, S-10L THRU S-10R (UPPER LOBE) STA 1180 THRU STA 1460, S-27 & S-28 STA 1400 THRU STA 1460, S-29 STA 660 THRU STA 900, S-27

TABLE III

**Fuselage Stringer Repair S-1 thru S-30 - 757-SF
Figure 201 (Sheet 5 of 8)**

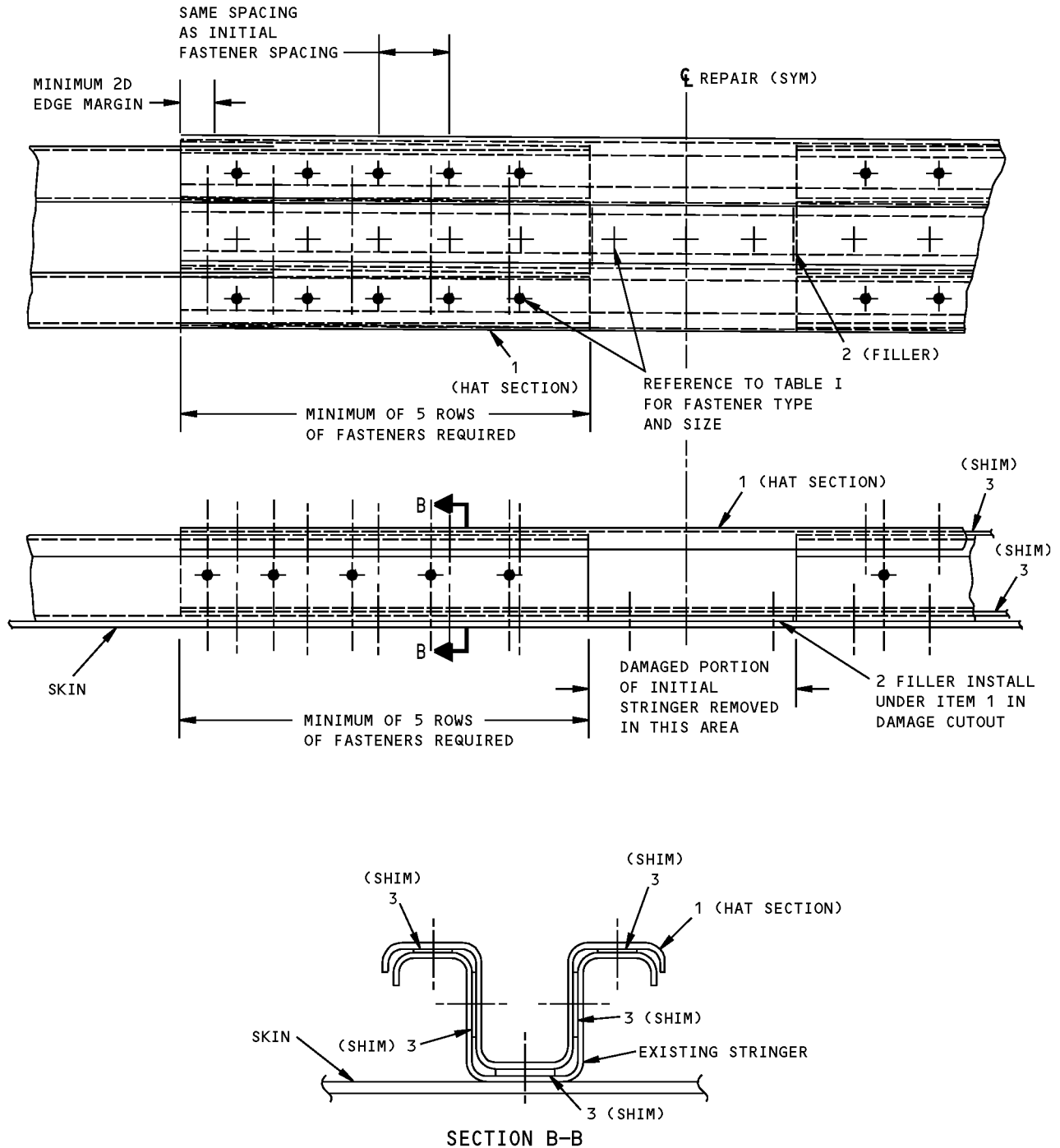
**757-200
STRUCTURAL REPAIR MANUAL**



FOR TYPE I STRINGERS WITH A GAGE OF 0.090 OR LESS
AND FOR TYPE II STRINGERS WITH A GAGE OF 0.063 OR LESS
DETAIL I

**Fuselage Stringer Repair S-1 thru S-30 - 757-SF
Figure 201 (Sheet 6 of 8)**

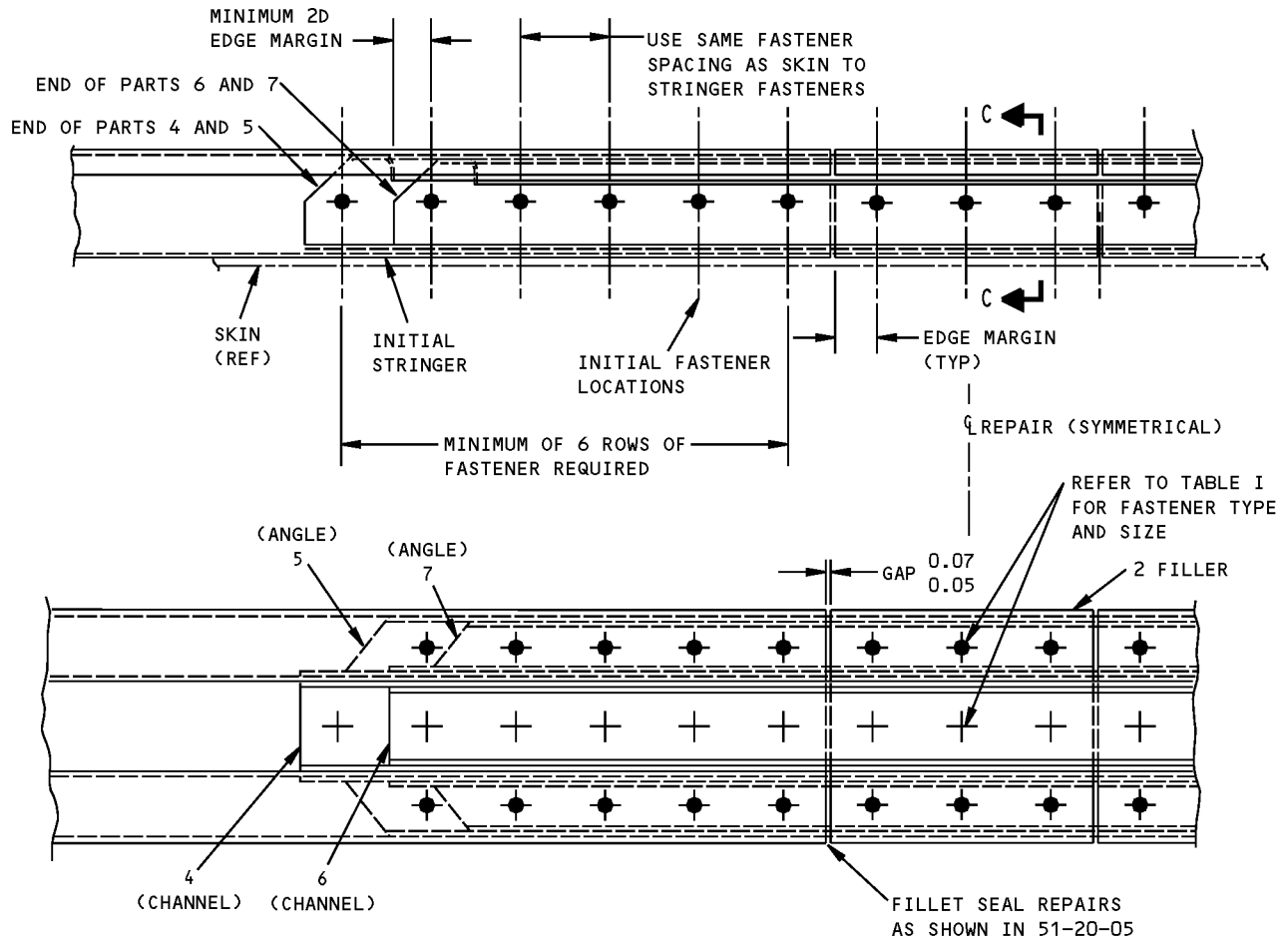
**757-200
STRUCTURAL REPAIR MANUAL**



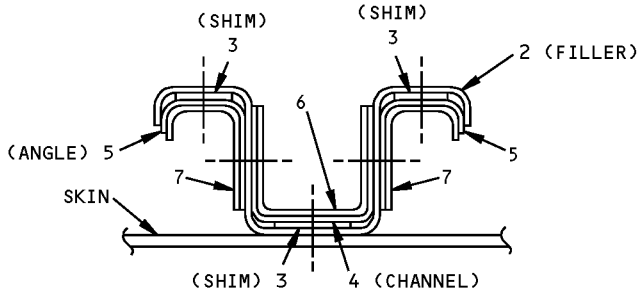
FOR TYPE II STRINGERS WITH A GAGE BETWEEN 0.064 AND 0.090
DETAIL II

**Fuselage Stringer Repair S-1 thru S-30 - 757-SF
Figure 201 (Sheet 7 of 8)**

**757-200
STRUCTURAL REPAIR MANUAL**



TOP VIEW



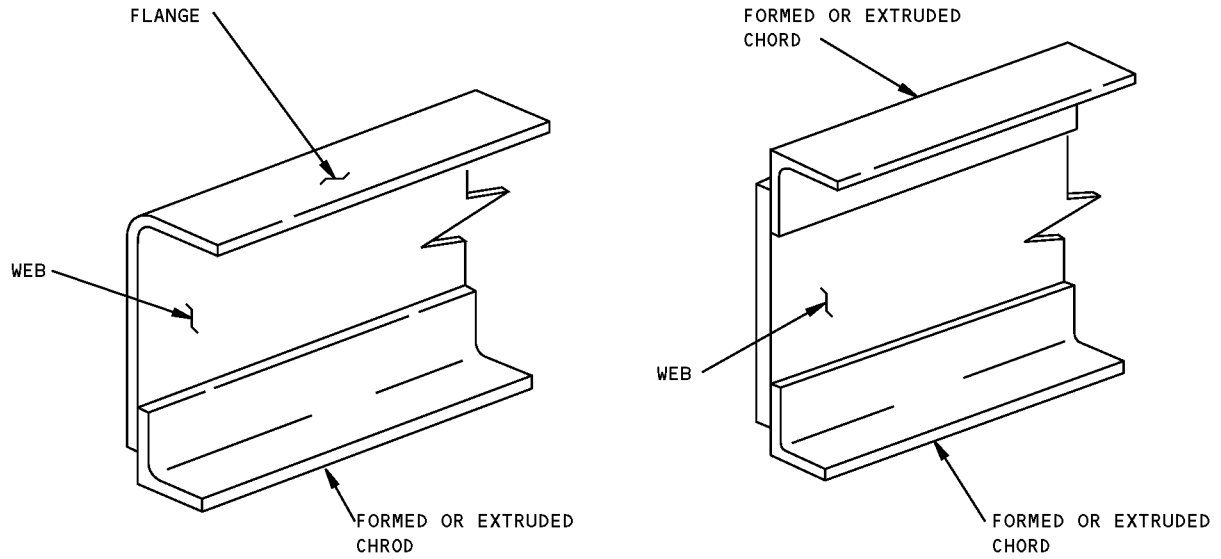
SECTION C-C

FOR TYPE I OR II STRINGERS WITH GAGE GREATER THAN 0.090
DETAIL III

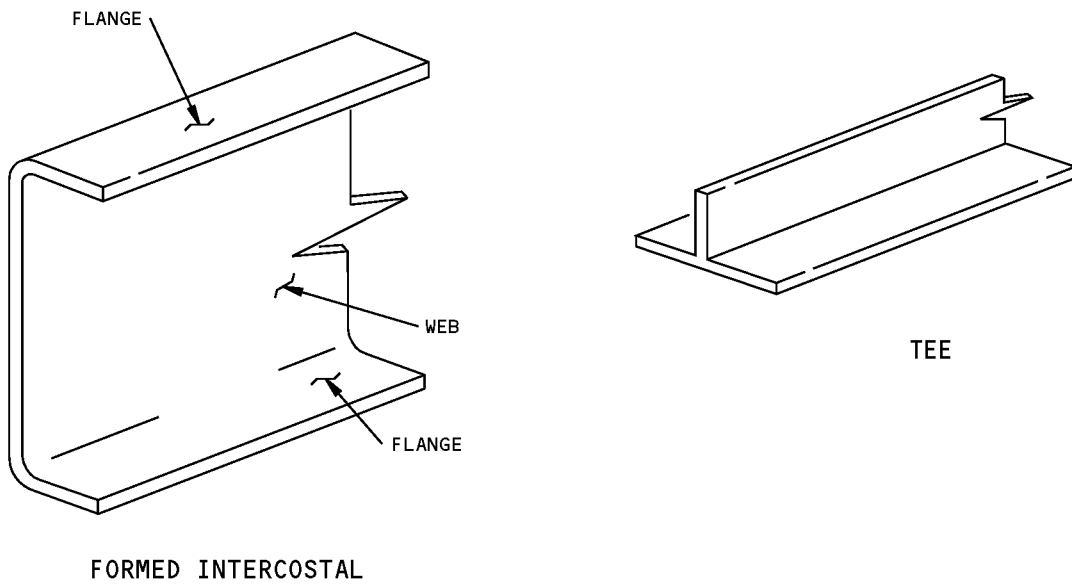
**Fuselage Stringer Repair S-1 thru S-30 - 757-SF
Figure 201 (Sheet 8 of 8)**

**757-200
STRUCTURAL REPAIR MANUAL**

ALLOWABLE DAMAGE 1 - INTERCOSTALS



BUILT-UP INTERCOSTALS



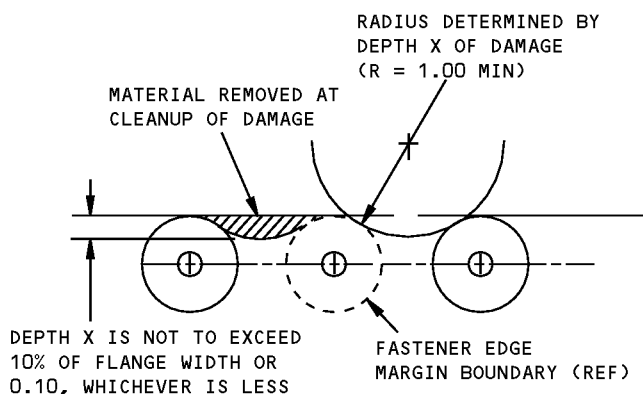
**Intercostals Allowable Damage
Figure 101 (Sheet 1 of 3)**

STRUCTURAL REPAIR MANUAL

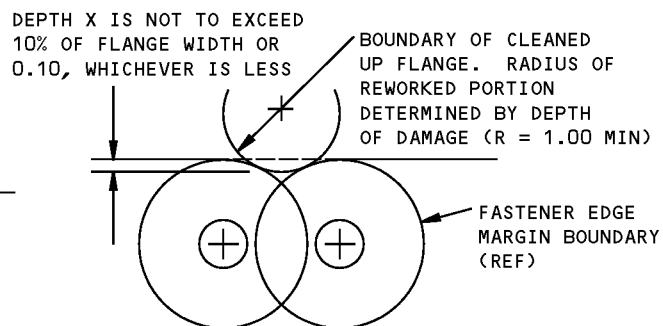
DESCRIPTION	CRACKS	NICKS, GOUGES AND CORROSION	DENTS	HOLES AND PUNCTURES
BUILT-UP INTERCOSTAL				
EXTRUDED CHORD	A	D	NOT ALLOWED	G
FORMED CHORD	B	E	SEE DETAIL III	G
WEB	C	F	SEE DETAIL III	G
FLANGE	B	E	SEE DETAIL III	G
FORMED INTERCOSTAL				
WEB	C	F	SEE DETAIL III	G
FLANGE	B	E	SEE DETAIL III	G
TEE	A	D	NOT ALLOWED	G

NOTES

- THIS ALLOWABLE DAMAGE DATA MUST NOT BE USED FOR JACKSCREW SUPPORT INTERCOSTALS
 - REFINISH REWORKED AREAS PER 51-20 OF THE MAINTENANCE MANUAL
- A** CRACKS NOT ALLOWED EXCEPT FOR EDGE CRACKS WHICH MUST BE REMOVED PER DETAILS I AND V
- B** CRACKS NOT ALLOWED EXCEPT FOR EDGE CRACKS WHICH MUST BE REMOVED PER DETAIL I
- C** CRACKS NOT ALLOWED EXCEPT FOR EDGE CRACKS WHICH MUST BE REMOVED PER DETAILS I AND IV
- D** REMOVE DAMAGE PER DETAILS I, II, AND V
- E** REMOVE DAMAGE PER DETAILS I AND II
- F** REMOVE DAMAGE PER DETAILS I, II AND IV
- G** CLEAN OUT DAMAGE UP TO 0.25 MAX DIA AND NOT CLOSER THAN 1.0 INCH TO FASTENER HOLE. FILL HOLE WITH A 2117-T3 OR T4 ALUMINUM RIVET INSTALLED WET WITH BMS 5-95 SEALANT. ALL OTHER HOLES TO BE REPAIRED



DAMAGE CLEANUP OF EDGES WHERE FASTENER EDGE MARGINS DO NOT OVERLAP

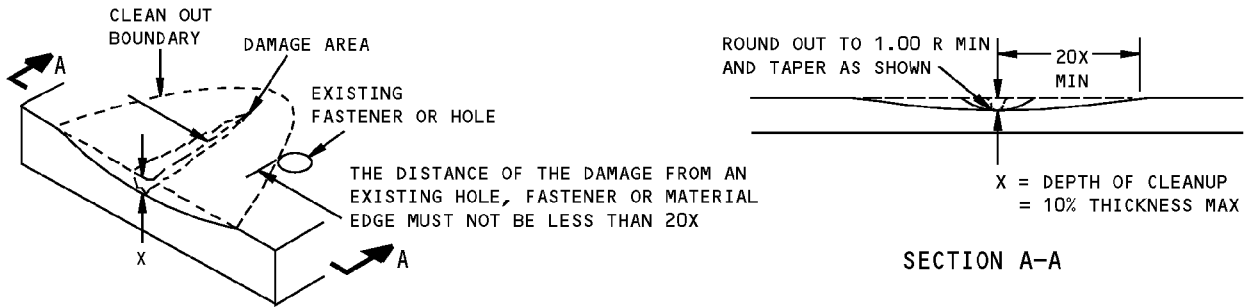


DAMAGE CLEANUP OF EDGES WHERE FASTENER EDGE MARGINS OVERLAP

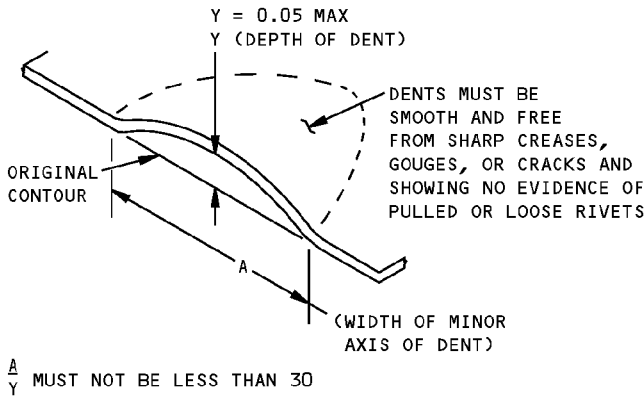
DETAIL I

**Intercostals Allowable Damage
Figure 101 (Sheet 2 of 3)**

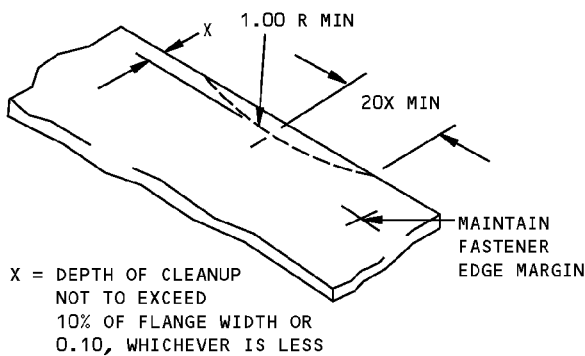
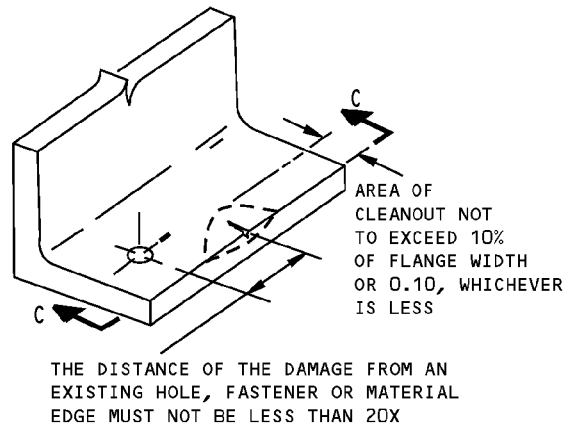
**757-200
STRUCTURAL REPAIR MANUAL**



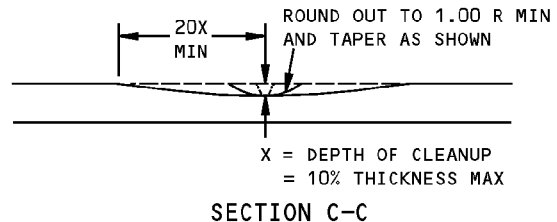
**REMOVAL OF NICK, GOUGE AND SCRATCH DAMAGE ON A SURFACE
DETAIL II**



**ALLOWABLE DAMAGE FOR DENT
DETAIL III**



**REMOVAL OF NICK OR CRACK
DAMAGE ON AN EDGE
DETAIL IV**

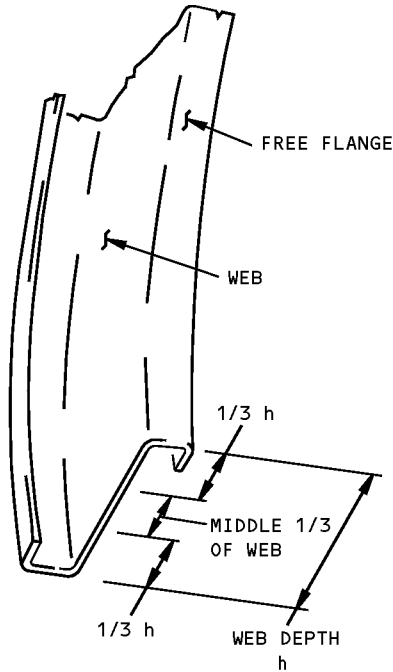


**REMOVAL OF NICK OR CRACK
DAMAGE ON AN EDGE
DETAIL V**

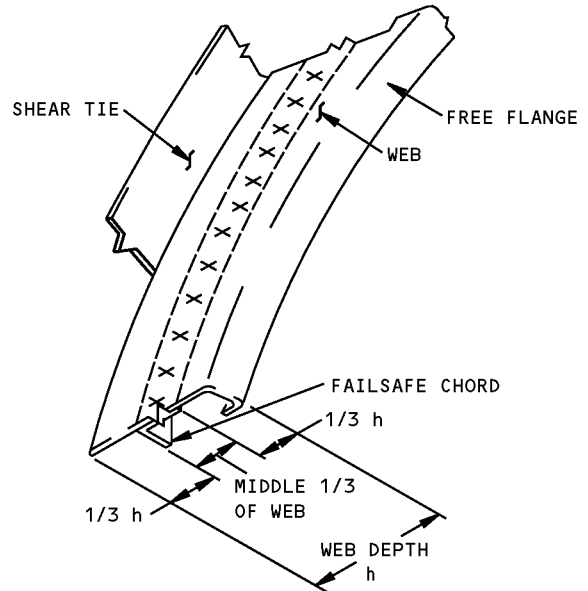
**Intercostals Allowable Damage
Figure 101 (Sheet 3 of 3)**

**757-200
STRUCTURAL REPAIR MANUAL**

ALLOWABLE DAMAGE 1 - FUSELAGE FRAMES



ZEE FRAME



BUILT-UP FRAME

TYPICAL FRAME SECTIONS

DESCRIPTION		CRACKS	NICKS, GOUGES AND CORROSION	DENTS	HOLES AND PUNCTURES
ZEE FRAMES		A	B	ALLOWED IN WEB ONLY. SEE DETAIL III	ALLOWED IN MIDDLE 1/3 OF WEB ONLY C
BUILT-UP FRAME	WEB	A	B		
	FLANGE	A	B	NOT ALLOWED	NOT ALLOWED
	FAILSAFE CHORD	A	B	NOT ALLOWED	NOT ALLOWED

**Fuselage Frames Allowable Damage
Figure 101 (Sheet 1 of 4)**



757-200

STRUCTURAL REPAIR MANUAL

NOTES

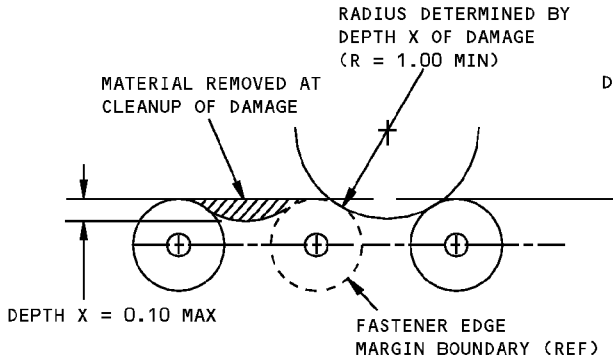
- THIS ALLOWABLE DAMAGE DATA IS APPLICABLE TO PASSENGER AIRPLANES ONLY
 - REFINISH REWORKED AREAS PER 51-20 OF THE MAINTENANCE MANUAL
 - THE TOTAL CROSS-SECTIONAL AREA REMOVED BY ANY TYPE OF DAMAGE CLEANUP MUST NOT EXCEED 10 PERCENT OF THE ORIGINAL NET CROSS-SECTIONAL AREA OF THE WEB OR FLANGE AS APPROPRIATE. THE NET CROSS-SECTIONAL AREA IS THE ORIGINAL CROSS-SECTIONAL AREA LESS LIGHTENING OR FASTENER HOLES PROVIDED AT MANUFACTURER. SEE DETAIL V
- A** CRACKS NOT ALLOWED EXCEPT FOR EDGE CRACKS WHICH MUST BE REMOVED PER DETAILS I AND IV
- B** REMOVE DAMAGE PER DETAILS I, II AND IV
- C** CLEAN OUT DAMAGE UP TO 0.18 DIA MAX AND NOT CLOSER THAN 3D TO FASTENER HOLE, MATERIAL EDGE OR OTHER DAMAGE WITH A MAXIMUM OF 4 HOLES IN 6 INCHES. SEE DETAIL II. FILL HOLE WITH 2117-T3 ALUMINUM RIVET INSTALLED WET WITH BMS 5-95 SEALANT. ALL OTHER HOLES TO BE REPAIRED

Fuselage Frames Allowable Damage
Figure 101 (Sheet 2 of 4)

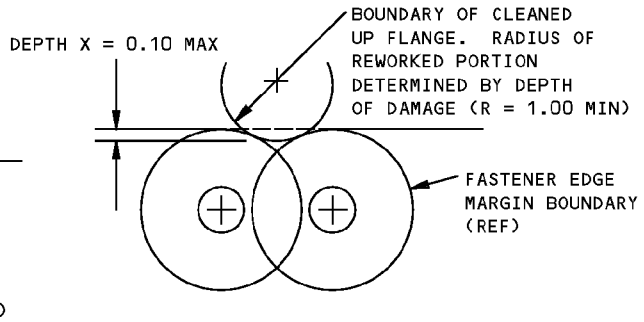
D634N201

ALLOWABLE DAMAGE 1
53-00-07
Page 102
Jan 20/2005

STRUCTURAL REPAIR MANUAL

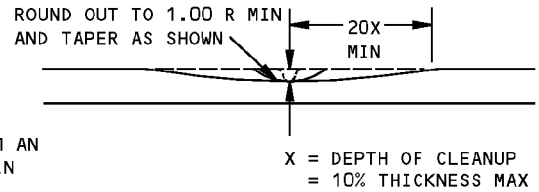
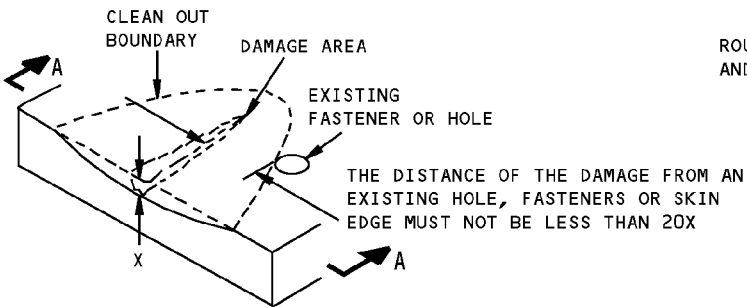


DAMAGE CLEANUP OF EDGES WHERE FASTENER EDGE MARGINS DO NOT OVERLAP



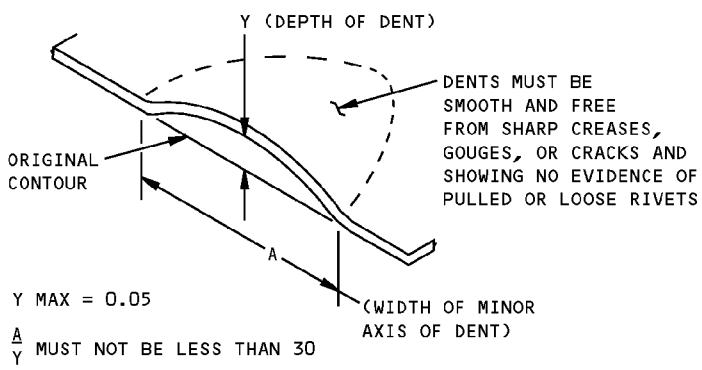
DAMAGE CLEANUP OF EDGES WHERE FASTENER EDGE MARGINS OVERLAP

DETAIL I



SECTION A-A

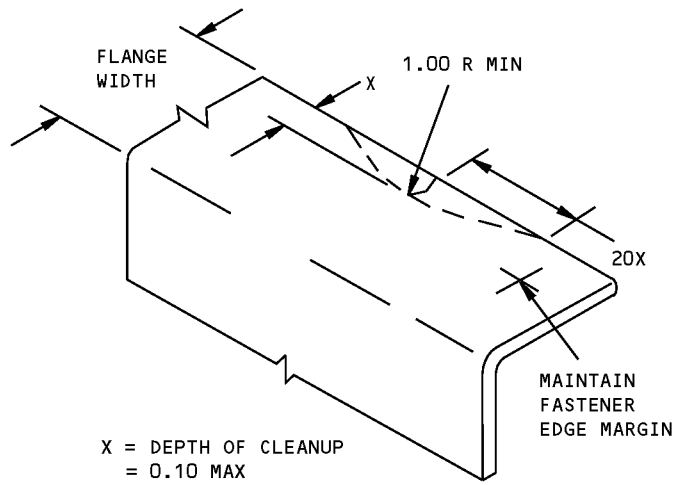
REMOVAL OF NICK, GOUGE AND SCRATCH DAMAGE ON A SURFACE
DETAIL II



ALLOWABLE DAMAGE FOR DENT
DETAIL III

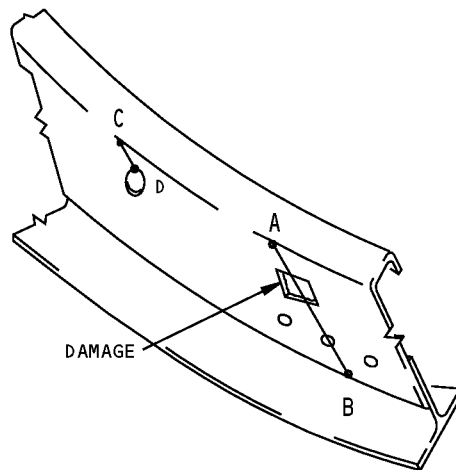
**Fuselage Frames Allowable Damage
Figure 101 (Sheet 3 of 4)**

**757-200
STRUCTURAL REPAIR MANUAL**



**REMOVAL OF NICK OR CRACK
DAMAGE ON AN EDGE**

DETAIL IV



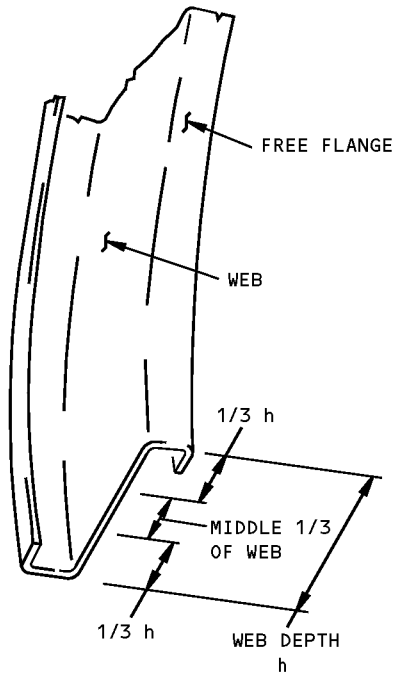
LOSS IN CROSS-SECTIONAL AREA ALONG ANY LINE A-B OR C-D DUE TO REMOVAL OF ANY TYPE OF DAMAGE MUST NOT EXCEED 10% OF ORIGINAL NET CROSS-SECTIONAL AREA

DETAIL V

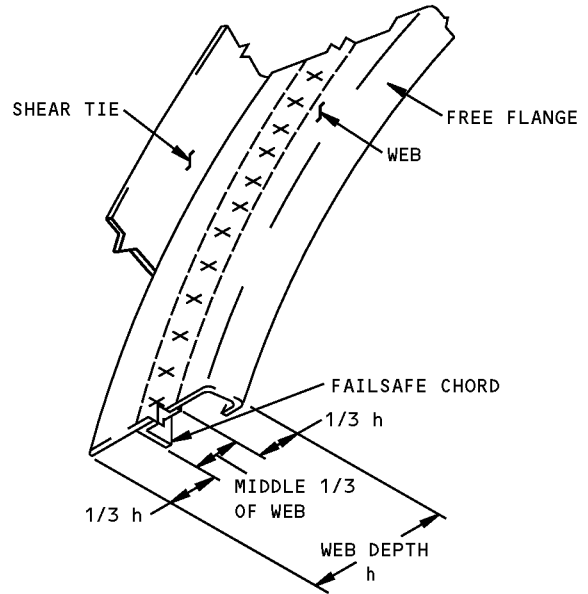
**Fuselage Frames Allowable Damage
Figure 101 (Sheet 4 of 4)**

**757-200
STRUCTURAL REPAIR MANUAL**

ALLOWABLE DAMAGE 2 - FUSELAGE FRAMES - 757-SF



ZEE FRAME



BUILT-UP FRAME

TYPICAL FRAME SECTIONS

DESCRIPTION		CRACKS	NICKS, GOUGES AND CORROSION	DENTS	HOLES AND PUNCTURES
ZEE FRAMES		A	B	ALLOWED IN WEB ONLY. SEE DETAIL III	ALLOWED IN MIDDLE 1/3 OF WEB ONLY C
BUILT-UP FRAME D	WEB	A	B		
	FLANGE	A	B	NOT ALLOWED	NOT ALLOWED
	FAILSAFE CHORD	A	B	NOT ALLOWED	NOT ALLOWED

**Fuselage Frames Allowable Damage - 757-SF
Figure 101 (Sheet 1 of 4)**

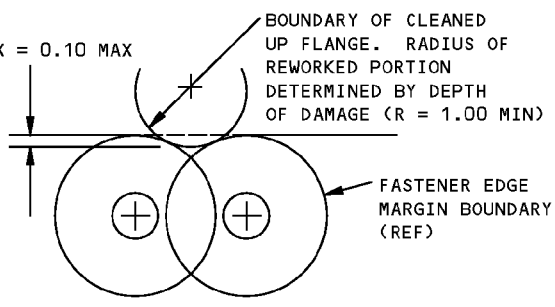
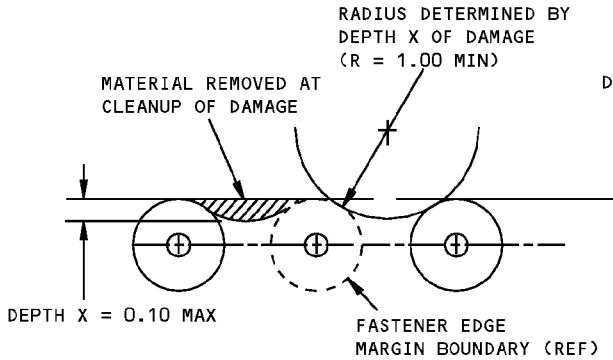
757-200
STRUCTURAL REPAIR MANUAL

NOTES

- THIS ALLOWABLE DAMAGE DATA IS APPLICABLE TO 757-SF AIRPLANES ONLY.
 - THIS ALLOWABLE DAMAGE IS A CATEGORY A REPAIR FOR 757-SF AIRPLANES. THE INSPECTIONS GIVEN IN THE MAINTENANCE PLANNING DATA (MPD) AND ASSOCIATED SUPPLEMENT ARE SUFFICIENT TO MAINTAIN THE DAMAGE TOLERANCE OF THE INITIAL STRUCTURE WITH THIS ALLOWABLE DAMAGE. REFER TO SRM 51-00-06 FOR REPAIR CATEGORIES AND DEFINITIONS.
 - ALL DIMENSIONS ARE IN INCHES.
 - D = THE FASTENER DIAMETER.
 - REFER TO AMM 51-21 FOR FINISHES IN THE REWORK AREA
 - THE TOTAL CROSS-SECTIONAL AREA REMOVED BY ANY TYPE OF DAMAGE CLEANUP MUST NOT EXCEED 10 PERCENT OF THE INITIAL NET CROSS-SECTIONAL AREA OF THE WEB OR FLANGE AS APPROPRIATE. THE NET CROSS-SECTIONAL AREA IS THE INITIAL CROSS-SECTIONAL AREA LESS LIGHTENING OR FASTENER HOLES PROVIDED AT MANUFACTURER. SEE DETAIL V
- A** CRACKS NOT PERMITTED EXCEPT FOR EDGE CRACKS WHICH MUST BE REMOVED AS SHOWN IN DETAILS I AND IV.
- B** REMOVE DAMAGE AS SHOWN IN DETAILS I, II AND IV.
- C** CLEAN OUT DAMAGE UP TO 0.18 DIA MAXIMUM AND NOT CLOSER THAN 3D TO FASTENER HOLE, MATERIAL EDGE OR OTHER DAMAGE WITH A MAXIMUM OF 4 HOLES IN 6 INCHES. SEE DETAIL II. FILL HOLE WITH 2117-T3 ALUMINUM RIVET INSTALLED WET WITH BMS 5-95 SEALANT. ALL OTHER HOLES TO BE REPAIRED.
- D** NO DAMAGE IS PERMITTED FOR SECTION 46 BUILT-UP FRAMES BETWEEN S-17 AND S-22 (L/R).
- E** FOR SECTION 46 BUILT-UP FRAMES BETWEEN S-13 AND S-17 (L/R), THE MAXIMUM DEPTH OF CLEANUP TO THE WEB IS 5 PERCENT OF THICKNESS.

Fuselage Frames Allowable Damage - 757-SF
Figure 101 (Sheet 2 of 4)

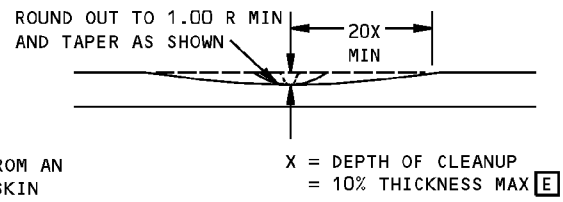
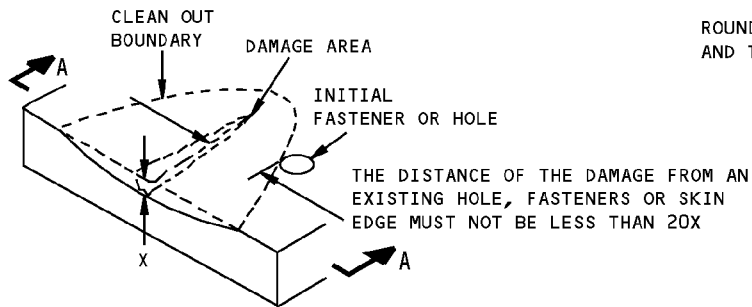
STRUCTURAL REPAIR MANUAL



DAMAGE CLEANUP OF EDGES WHERE FASTENER EDGE MARGINS DO NOT OVERLAP

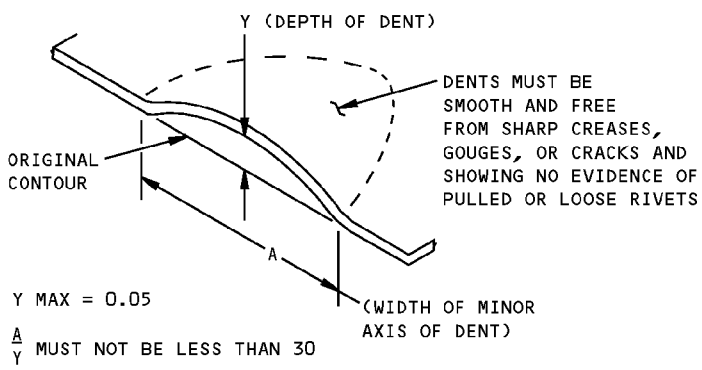
DAMAGE CLEANUP OF EDGES WHERE FASTENER EDGE MARGINS OVERLAP

DETAIL I



SECTION A-A

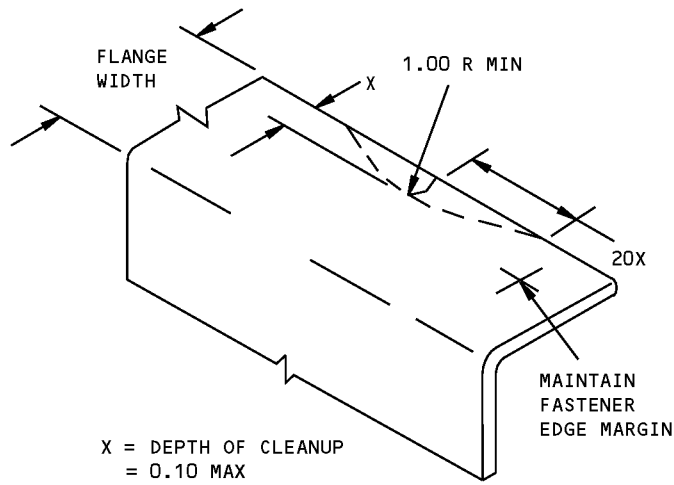
REMOVAL OF NICK, GOUGE AND SCRATCH DAMAGE ON A SURFACE
DETAIL II



ALLOWABLE DAMAGE FOR DENT
DETAIL III

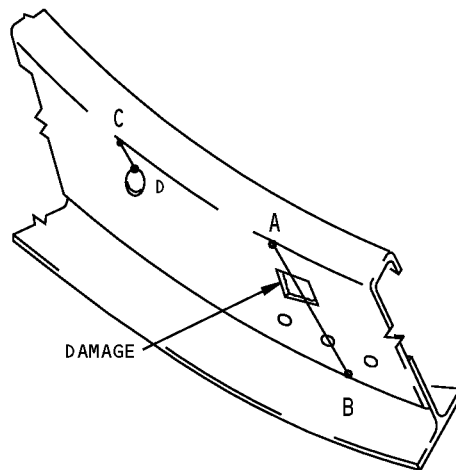
Fuselage Frames Allowable Damage - 757-SF
Figure 101 (Sheet 3 of 4)

**757-200
STRUCTURAL REPAIR MANUAL**



**REMOVAL OF NICK OR CRACK
DAMAGE ON AN EDGE**

DETAIL IV



LOSS IN CROSS-SECTIONAL AREA ALONG ANY LINE A-B OR C-D DUE TO REMOVAL OF ANY TYPE OF DAMAGE MUST NOT EXCEED 10% OF INITIAL NET CROSS-SECTIONAL AREA

DETAIL V

**Fuselage Frames Allowable Damage - 757-SF
Figure 101 (Sheet 4 of 4)**

STRUCTURAL REPAIR MANUAL

REPAIR 1 - FUSELAGE FORMED ZEE FRAME REPAIR

APPLICABILITY
THIS REPAIR IS APPLICABLE TO PASSENGER AIRPLANES ONLY.

REPAIR INSTRUCTIONS

1. Trim out the body frames as required.
2. Drill out fasteners joining stringer tie and frame to facilitate removal of damaged portion of frame. Drill out fasteners joining stringer tie and stringer only when needed to complete the repair, or when stringer tie is damaged. See Details I and II.
3. Make repair parts.
4. Assemble the repair parts and drill fastener holes.
5. Remove the repair parts and alodize all cut edges on original and repair parts.
6. Install repair parts with BMS 5-95 faying surface sealant as given in SRM 51-20-05. Install fasteners wet with BMS 5-95 sealant.
7. Restore original finish as given in AMM 51-21.

NOTES

- BREAK SHARP EDGES OF ORIGINAL AND REPAIR PARTS 0.015 TO 0.030.
- REMOVE ALL NICKS, SCRATCHES, BURRS, SHARP EDGES AND CORNERS FROM ORIGINAL AND REPAIR PARTS
- WHEN YOU USE THIS REPAIR REFER TO:
 - AMM 51-21 FOR INTERIOR AND EXTERIOR FINISHES
 - SRM 51-20-01 FOR PROTECTIVE TREATMENT OF METAL
 - SRM 51-20-05 FOR SEALING OF REPAIRS
 - SRM 51-40 FOR FASTENER CODE, REMOVAL, INSTALLATION, HOLE SIZES AND EDGE MARGINS.

- A** SAME GAGE AS ORIGINAL FRAME
- B** SHIM GAP BETWEEN STRINGER AND FRAME. INSTALL FASTENER COMMON TO STRINGER AT CENTER OF STRINGER FLANGE WIDTH.
- C** YOU CAN ORDER REPAIR CHANNEL PARTS AS SHOWN IN DRAWING NUMBER 691N0006 (SHEET 2) FROM BOEING SPARES.

FASTENER SYMBOLS

- + ORIGINAL FASTENER LOCATION
- ◆ REPAIR FASTENER LOCATION

REPAIR MATERIAL			
	PART	QTY	MATERIAL
1	CHANNEL	1	7075-T6 CLAD A C
2	CHANNEL	1	7075-T6 CLAD A C
3	FILLER	1	7075-T6 CLAD A

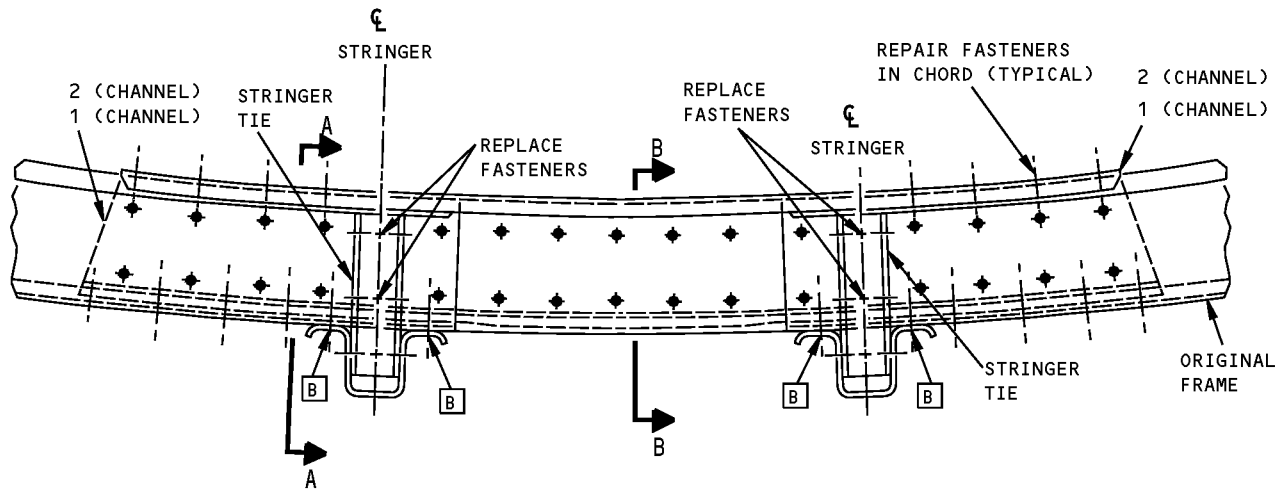
TABLE I

MINIMUM NUMBER OF FASTENERS REQUIRED IN EACH ROW ON EACH SIDE OF DAMAGE			
ORIGINAL ZEE SECTION	GAGE	FASTENER	QTY
BAC1517-2156	0.050	BACR15FT6D	5
BAC1517-2157	0.056	↓	5
BAC1517-2192	0.056		5
BAC1517-2155	0.063		5
BAC1517-2158	0.063		5
BAC1517-2159	0.071		6
BAC1517-2160	0.080		6
BAC1517-2161	0.090		BACR15FT8D

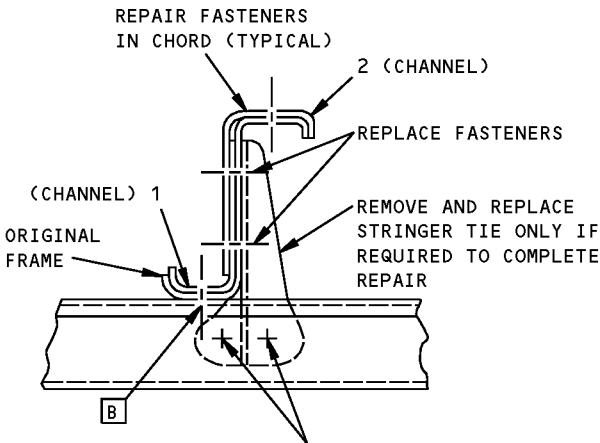
TABLE II

**Fuselage Formed Zee Frame Repair
Figure 201 (Sheet 1 of 3)**

**757-200
STRUCTURAL REPAIR MANUAL**

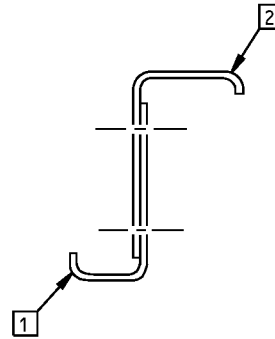


**REPAIR FOR FRAME DAMAGE BETWEEN TWO STRINGERS
DETAIL I**



REMOVE AND REPLACE AS NECESSARY
USING FASTENER OF SAME SIZE, TYPE
AND MATERIAL AS ORIGINALLY INSTALLED

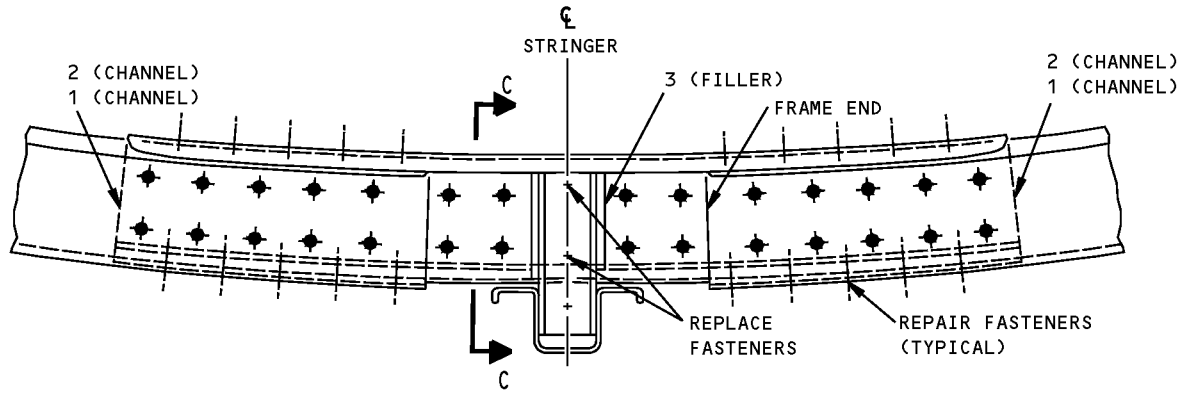
SECTION A-A



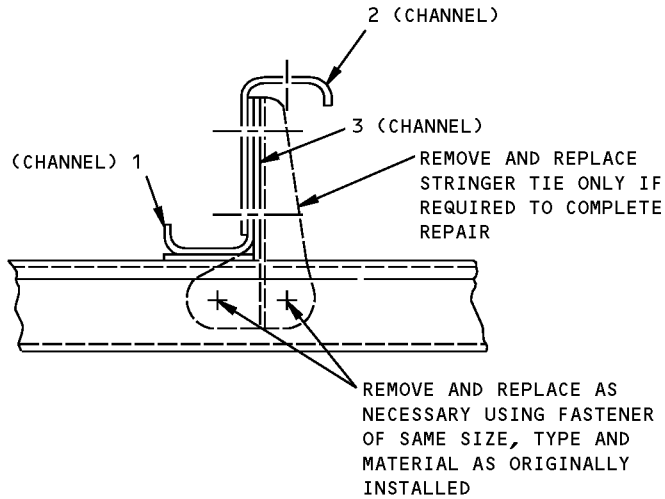
SECTION B-B

**Fuselage Formed Zee Frame Repair
Figure 201 (Sheet 2 of 3)**

**757-200
STRUCTURAL REPAIR MANUAL**



**REPAIR FOR DAMAGE AT A STRINGER
DETAIL II**



SECTION C-C

**Fuselage Formed Zee Frame Repair
Figure 201 (Sheet 3 of 3)**

STRUCTURAL REPAIR MANUAL

REPAIR 2 - FUSELAGE BUILT-UP FRAME WEB REPAIR

APPLICABILITY
THIS REPAIR IS APPLICABLE TO PASSENGER AIRPLANES ONLY.

REPAIR INSTRUCTIONS

1. Cut and remove damaged portion of web. Do not cut into any surrounding structure.
2. Fabricate repair parts per Detail I or II.
3. Assemble the repair parts and drill the fastener holes. See Table II for rows of rivets required and rivet spacing.
4. Remove repair parts.
5. Break sharp edges of original and repair parts 0.015 to 0.030.
6. Remove all nicks, scratches, burrs, sharp edges and corners from original and repair parts.
7. Alodize the repair parts and the raw edges of the original parts per 51-20-01.
8. Apply one coat of BMS 10-11, Type 1 primer to all repair parts in accordance with 51-24 of the 757 Maintenance Manual.
9. Install the repair parts. Install rivets wet with BMS 5-95.
10. Restore original finish per 51-21 of the 757 Maintenance Manual.

NOTES

- FOR CHEM-MILLED WEBS INSTALL REPAIR PART ON SIDE OF WEB WHICH IS NOT CHEM-MILLED IF POSSIBLE. WHERE NOT POSSIBLE, SHIMS MAY BE USED TO MAKE UP FOR VARIATIONS IN THICKNESS
- REFER TO THE FOLLOWING WHEN USING THIS REPAIR.
 - 51-10-00 FOR INVESTIGATION AND CLEANUP OF DAMAGE
 - 51-20-01 FOR PROTECTIVE TREATMENT OF METAL
 - 51-20-05 FOR SEALING OF REPAIRS
 - 51-21 OF THE 757 MAINTENANCE MANUAL FOR INTERIOR AND EXTERIOR FINISHES
 - 51-40 FOR FASTENER CODE, REMOVAL, INSTALLATION, HOLE SIZES AND EDGE MARGINS

NOTES (CONT)

- A** 2024-T3 MAY BE SUBSTITUTED FOR 2024-T42
- B** SEE TABLE II FOR ROW SPACING AND NUMBER OF ROWS REQUIRED
- C** MAKE NEW STRINGER CLIPS FROM CLAD 7075-T6 MATERIAL AS REQUIRED TO PROVIDE EDGE MARGIN AT RIVET LOCATIONS THRU STRINGER

SYMBOLS

- + ORIGINAL FASTENER LOCATION
- REPAIR FASTENER LOCATION

REPAIR MATERIAL			
PART	QTY	MATERIAL	A
1 REPAIR PLATE	1	SAME MATERIAL AND ONE GAGE THICKER THAN ORIGINAL	
2 REPAIR PLATE	1	SAME MATERIAL AND GAGE AS ORIGINAL	
3 SPLICE PLATE	2	SAME MATERIAL AND ONE GAGE THICKER THAN ORIGINAL	

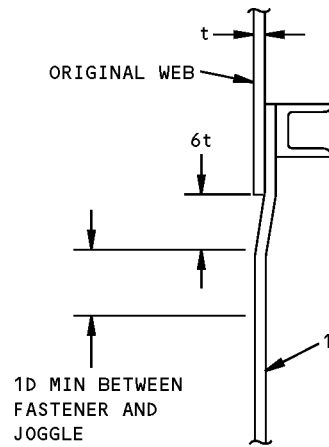
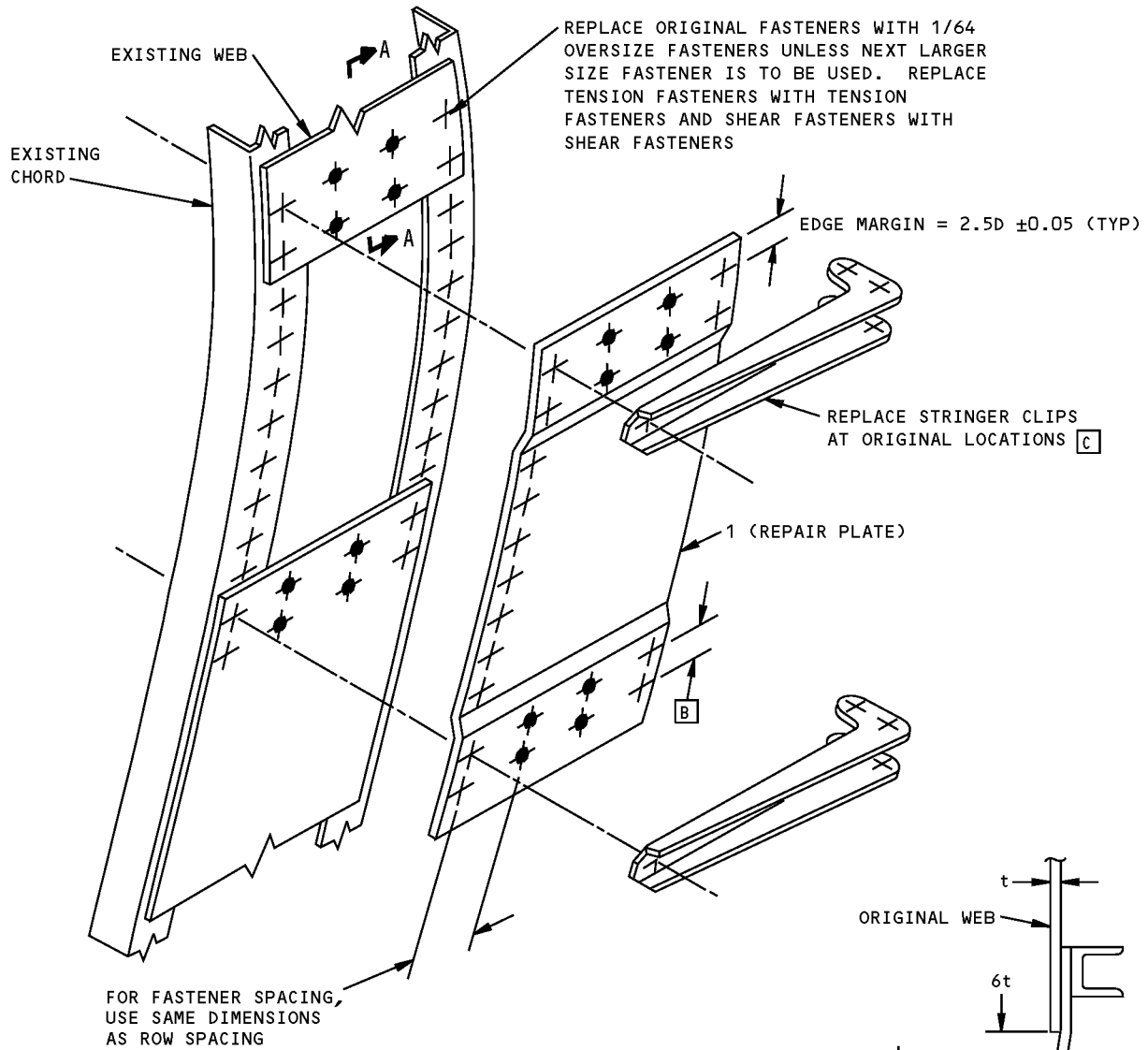
TABLE I

REPAIR FASTENER		ROW SPACING	ORIGINAL WEB THICKNESS	NUMBER ROWS REQUIRED
TYPE	DIA			
BACR15FT"AD"	5/32	0.60 TO 0.68	0.025 TO 0.050	2
	3/16	0.71 TO 0.81	0.025 TO 0.056	2
	1/4	0.94 TO 1.06	0.040 TO 0.080	2
BACB30MY"K"	3/16	0.60 TO 0.68	0.025 TO 0.125	2
	1/4	0.71 TO 0.81	0.040 TO 0.180	2
	5/16	0.94 TO 1.06	0.060 TO 0.190	2

TABLE II

**Fuselage Built-Up Frame Web Repair
Figure 201 (Sheet 1 of 3)**

**757-200
STRUCTURAL REPAIR MANUAL**



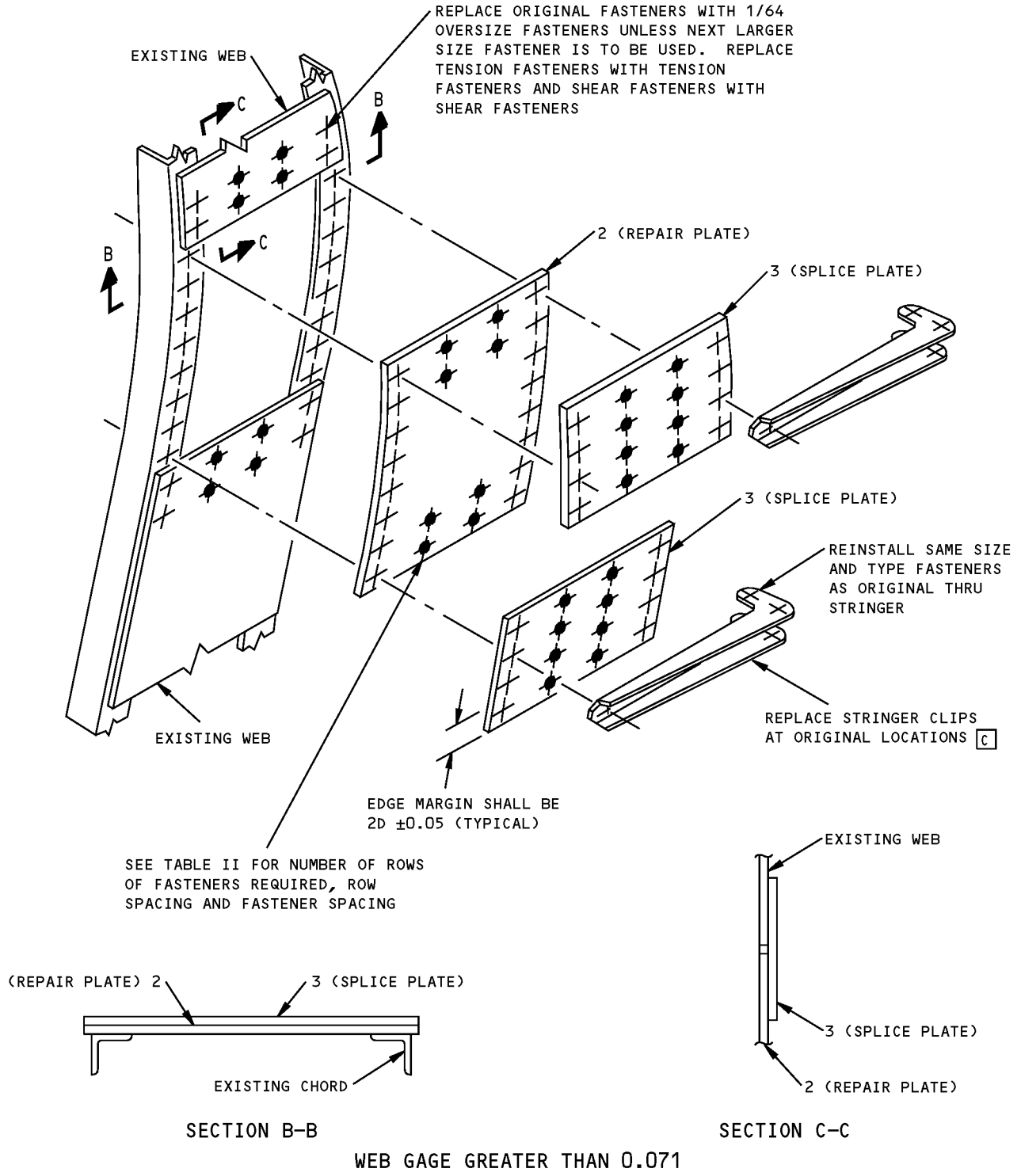
SECTION A-A

WEB GAGE 0.071 OR LESS

DETAIL I

**Fuselage Built-Up Frame Web Repair
Figure 201 (Sheet 2 of 3)**

**757-200
STRUCTURAL REPAIR MANUAL**



DETAIL II

**Fuselage Built-Up Frame Web Repair
Figure 201 (Sheet 3 of 3)**

STRUCTURAL REPAIR MANUAL

REPAIR 3 - FUSELAGE FORMED ZEE FRAME REPAIR - 757-SF

APPLICABILITY
THIS REPAIR IS APPLICABLE TO 757-SF AIRPLANES ONLY.

REPAIR INSTRUCTIONS

1. Trim out the body frames as required.
2. Drill out fasteners joining stringer tie and frame to facilitate removal of damaged portion of frame. Drill out fasteners joining stringer tie and stringer only when needed to complete the repair, or when stringer tie is damaged. See Details I and II.
3. Make repair parts.
4. Assemble the repair parts and drill fastener holes.
5. Disassemble the repair parts.
6. Break sharp edges of the initial and the repair parts 0.015 and 0.030 inch.
7. Remove all nicks, scratches, burrs, sharp edges and corners from the initial and the repair parts.
8. Apply a chemical conversion coating to the aluminum repair parts and the bare surfaces of the initial part. Refer to SRM 51-20-01.
9. Install repair parts with BMS 5-95 faying surface sealant as given in SRM 51-20-05. Install fasteners wet with BMS 5-95 sealant.
10. Restore initial finish in accordance with AMM 51-21.

NOTES

- THIS REPAIR IS A CATEGORY B REPAIR. THIS CATEGORY B REPAIR HAS FAA APPROVAL IF YOU DO THE INSPECTIONS AT THE SPECIFIED THRESHOLD AND INTERVALS AS GIVEN IN DETAILS I AND II.
- WHEN YOU USE THIS REPAIR REFER TO:
 - AMM 51-21 FOR INTERIOR AND EXTERIOR FINISHES
 - SRM 51-20-01 FOR PROTECTIVE TREATMENT OF METAL
 - SRM 51-20-05 FOR SEALING OF REPAIRS
 - SRM 51-40 FOR FASTENER CODE, REMOVAL, INSTALLATION, HOLE SIZES AND EDGE MARGINS.

- A** SAME GAGE AS INITIAL FRAME.
- B** SHIM GAP BETWEEN STRINGER AND FRAME. INSTALL FASTENER COMMON TO STRINGER AT CENTER OF STRINGER FLANGE WIDTH.

C YOU CAN ORDER REPAIR CHANNEL PARTS AS SHOWN IN DRAWING NUMBER 691N0006 (SHEET 2) FROM BOEING SPARES.

D INSPECT FOR CRACKS IN THE INITIAL FRAME AROUND THE HEAD OF THE FASTENERS WHERE INDICATED.

DO THE INITIAL INSPECTION BEFORE ACCUMULATION OF 10,000 FLIGHT CYCLES AFTER THE REPAIR. INSPECT AS FOLLOWS:

- DO A HIGH FREQUENCY EDDY CURRENT (HFEC) INSPECTION EVERY 12,000 FLIGHT CYCLES AS GIVEN IN NDT PART 6, 51-00-01. REPEAT THIS INSPECTION AT EVERY 12,000 FLIGHT CYCLE INTERVALS. AS AN ALTERNATIVE, DO A DETAILED VISUAL INSPECTION AT 9000 FLIGHT CYCLES INTERVALS AFTER THE INITIAL INSPECTION.

FASTENER SYMBOLS

- + INITIAL FASTENER LOCATION
- ⊕ REPAIR FASTENER LOCATION

REPAIR MATERIAL			
	PART	QTY	MATERIAL
1	CHANNEL	1	7075-T6 CLAD A C
2	CHANNEL	1	7075-T6 CLAD A C
3	FILLER	1	7075-T6 CLAD A

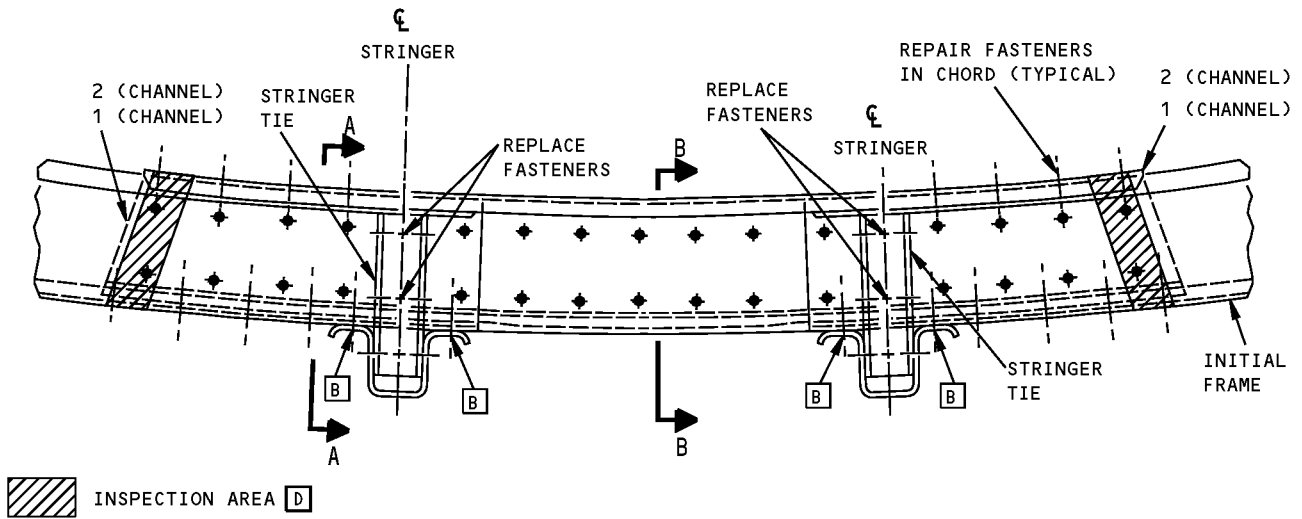
TABLE I

MINIMUM NUMBER OF FASTENERS REQUIRED IN EACH ROW ON EACH SIDE OF DAMAGE			
ORIGINAL ZEE SECTION	GAGE	FASTENER	QTY
BAC1517-2156	0.050	BACR15FT6D	5
BAC1517-2157	0.056	↓	5
BAC1517-2192	0.056		5
BAC1517-2155	0.063		5
BAC1517-2158	0.063		5
BAC1517-2159	0.071		6
BAC1517-2160	0.080		6
BAC1517-2161	0.090		BACR15FT8D

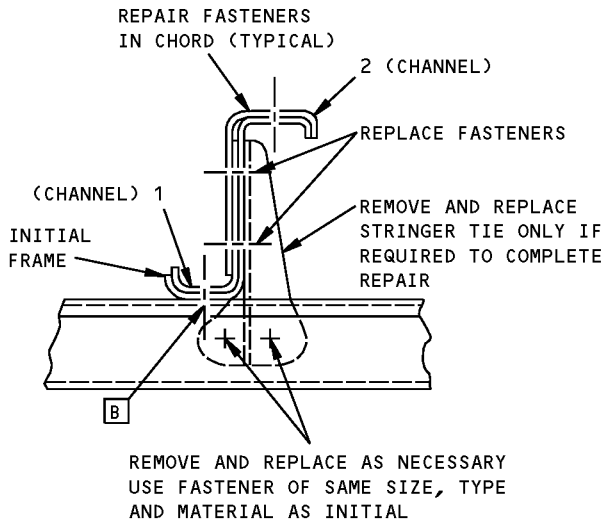
TABLE II

**Fuselage Formed Zee Frame Repair - 757-SF
Figure 201 (Sheet 1 of 3)**

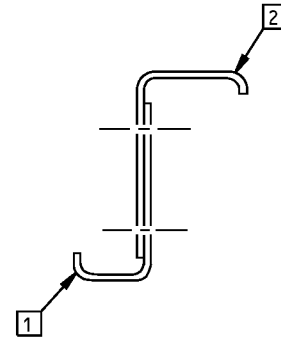
**757-200
STRUCTURAL REPAIR MANUAL**



**REPAIR FOR FRAME DAMAGE BETWEEN TWO STRINGERS
DETAIL I **D****



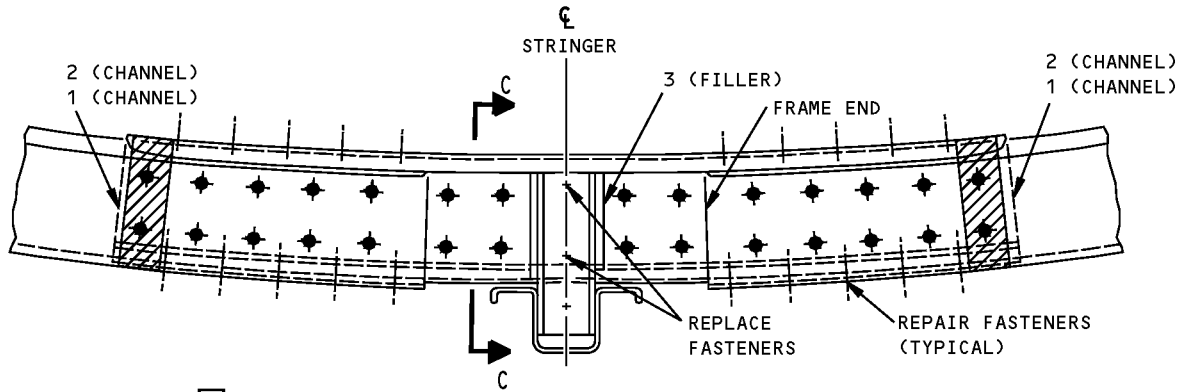
SECTION A-A



SECTION B-B

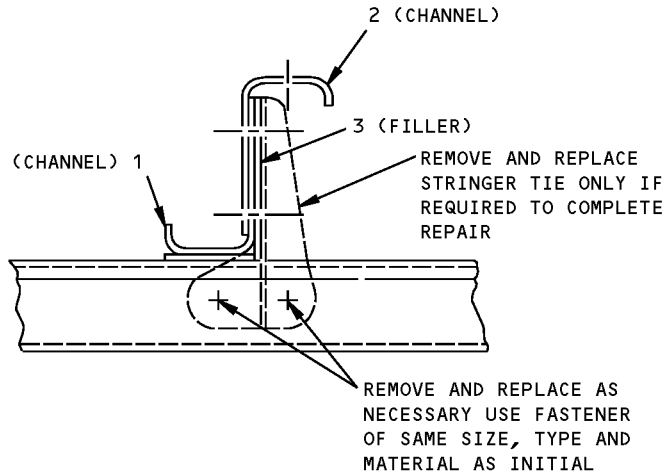
**Fuselage Formed Zee Frame Repair - 757-SF
Figure 201 (Sheet 2 of 3)**

**757-200
STRUCTURAL REPAIR MANUAL**



 INSPECTION AREA **D**

**REPAIR FOR DAMAGE AT A STRINGER
DETAIL II **D****



SECTION C-C

**Fuselage Formed Zee Frame Repair - 757-SF
Figure 201 (Sheet 3 of 3)**

757-200 STRUCTURAL REPAIR MANUAL

REPAIR 4 - FUSELAGE BUILT-UP FRAME WEB REPAIR - 757-SF

APPLICABILITY
THIS REPAIR IS APPLICABLE TO 757-SF AIRPLANES ONLY.

REPAIR INSTRUCTIONS

1. Cut and remove damaged portion of web. Do not cut into any surrounding structure.
2. Fabricate repair parts per Detail I or II.
3. Assemble the repair parts and drill the fastener holes. See Table II for rows of rivets required and rivet spacing.
4. Disassemble the repair parts.
5. Break sharp edges of the initial and the repair parts 0.015 to 0.030 inch.
6. Remove all nicks, scratches, burrs, sharp edges and corners from initial and repair parts.
7. Apply a chemical conversion coating to the aluminum repair parts and the bare surfaces of the initial part. Refer to SRM 51-20-01.
8. Apply one layer of BMS 10-11, Type 1 primer to all repair parts in accordance with 51-24 of the 757 Maintenance Manual.
9. Install the repair parts. Install rivets wet with BMS 5-95.
10. Restore initial finish in accordance with AMM 51-21.

NOTES

- THIS REPAIR IS A CATEGORY B REPAIR. THIS CATEGORY B REPAIR HAS FAA APPROVAL IF YOU DO AN INITIAL DETAILED VISUAL INSPECTION ALONG THE OUTER ROW OF REPAIR FASTENERS COMMON TO THE FRAME WEB, INBOARD AND OUTER CHORDS UPON ACCUMULATION OF 40,000 OR 12,000 FLIGHT CYCLES FROM THE TIME OF REPAIR WHICHEVER OCCURS LATER. DO THE SAME INSPECTION THEREAFTER AT 12,000 FLIGHT CYCLES.
- FOR CHEM-MILLED WEBS INSTALL REPAIR PART ON SIDE OF WEB WHICH IS NOT CHEM-MILLED IF POSSIBLE. WHERE NOT POSSIBLE, SHIMS MAY BE USED TO MAKE UP FOR VARIATIONS IN THICKNESS
- REFER TO THE FOLLOWING WHEN USING THIS REPAIR:
 - AMM 51-21 OF THE 757 MAINTENANCE MANUAL FOR INTERIOR AND EXTERIOR FINISHES
 - 51-10-02 FOR INVESTIGATION AND CLEANUP OF DAMAGE

NOTES (CONT)

- SRM 51-20-01 FOR PROTECTIVE TREATMENT OF METAL
- SRM 51-20-05 FOR SEALING OF REPAIRS
- SRM 51-40 FOR FASTENER CODE, REMOVAL, INSTALLATION, HOLE SIZES AND EDGE MARGINS

- A** 2024-T3 MAY BE SUBSTITUTED FOR 2024-T42
- B** SEE TABLE II FOR ROW SPACING AND NUMBER OF ROWS REQUIRED
- C** MAKE NEW STRINGER CLIPS FROM CLAD 7075-T6 MATERIAL AS REQUIRED TO PROVIDE EDGE MARGIN AT RIVET LOCATIONS THRU STRINGER

SYMBOLS

- ✚ INITIAL FASTENER LOCATION
- ✚ REPAIR FASTENER LOCATION

REPAIR MATERIAL			
PART	QTY	MATERIAL	A
1 REPAIR PLATE	1	SAME MATERIAL AND ONE GAGE THICKER THAN INITIAL	
2 REPAIR PLATE	1	SAME MATERIAL AND GAGE AS INITIAL	
3 SPLICE PLATE	2	SAME MATERIAL AND ONE GAGE THICKER THAN INITIAL	

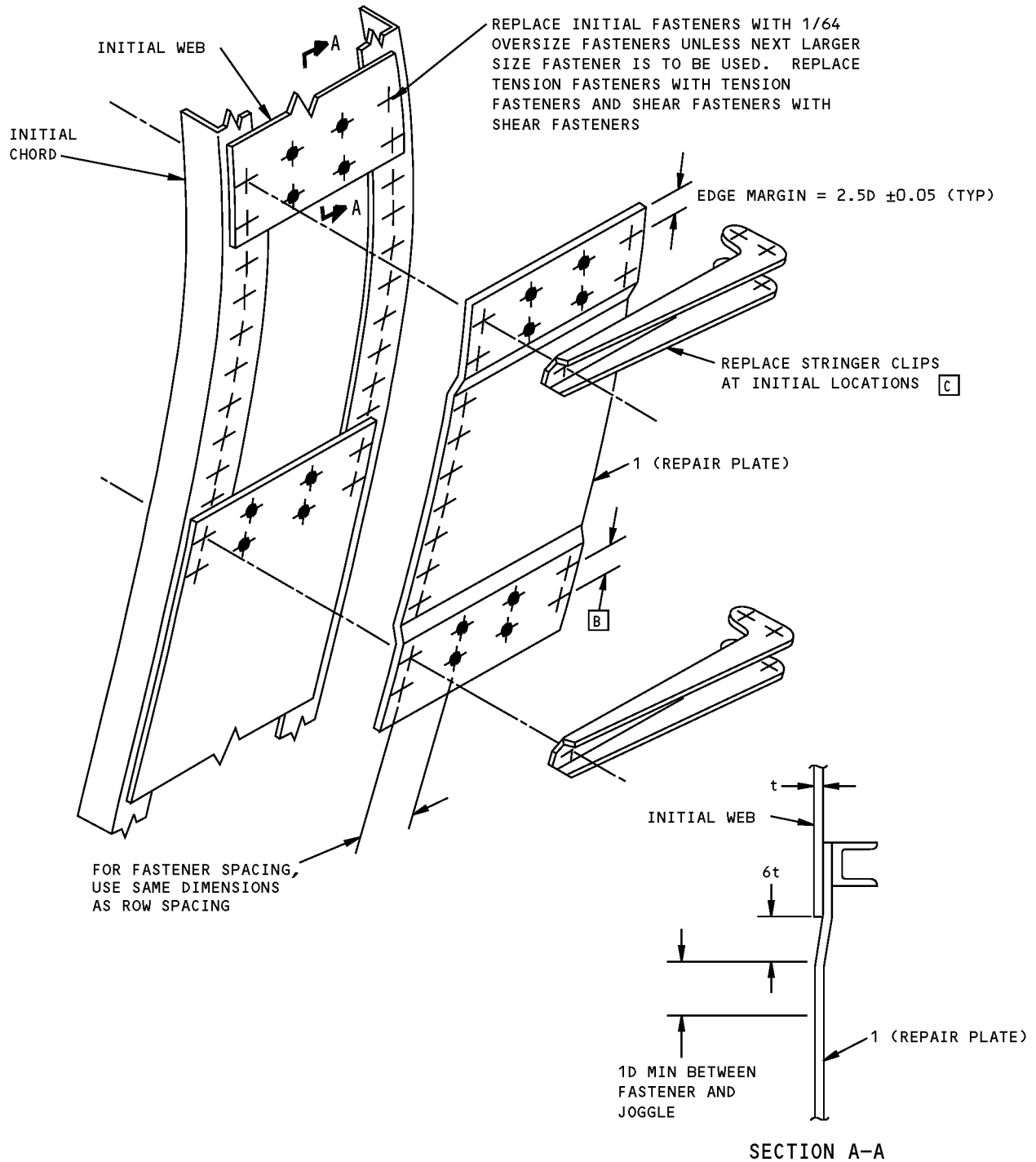
TABLE I

REPAIR FASTENER		ROW SPACING	INITIAL WEB THICKNESS	NUMBER ROWS REQUIRED
TYPE	DIA			
BACR15FT"AD"	5/32	0.60 TO 0.68	0.025 TO 0.050	2
	3/16	0.71 TO 0.81	0.025 TO 0.056	2
	1/4	0.94 TO 1.06	0.040 TO 0.080	2
BACB30MY"K"	3/16	0.60 TO 0.68	0.025 TO 0.125	2
	1/4	0.71 TO 0.81	0.040 TO 0.180	2
	5/16	0.94 TO 1.06	0.060 TO 0.190	2

TABLE II

Fuselage Built-Up Frame Web Repair - 757-SF Figure 201 (Sheet 1 of 3)

**757-200
STRUCTURAL REPAIR MANUAL**

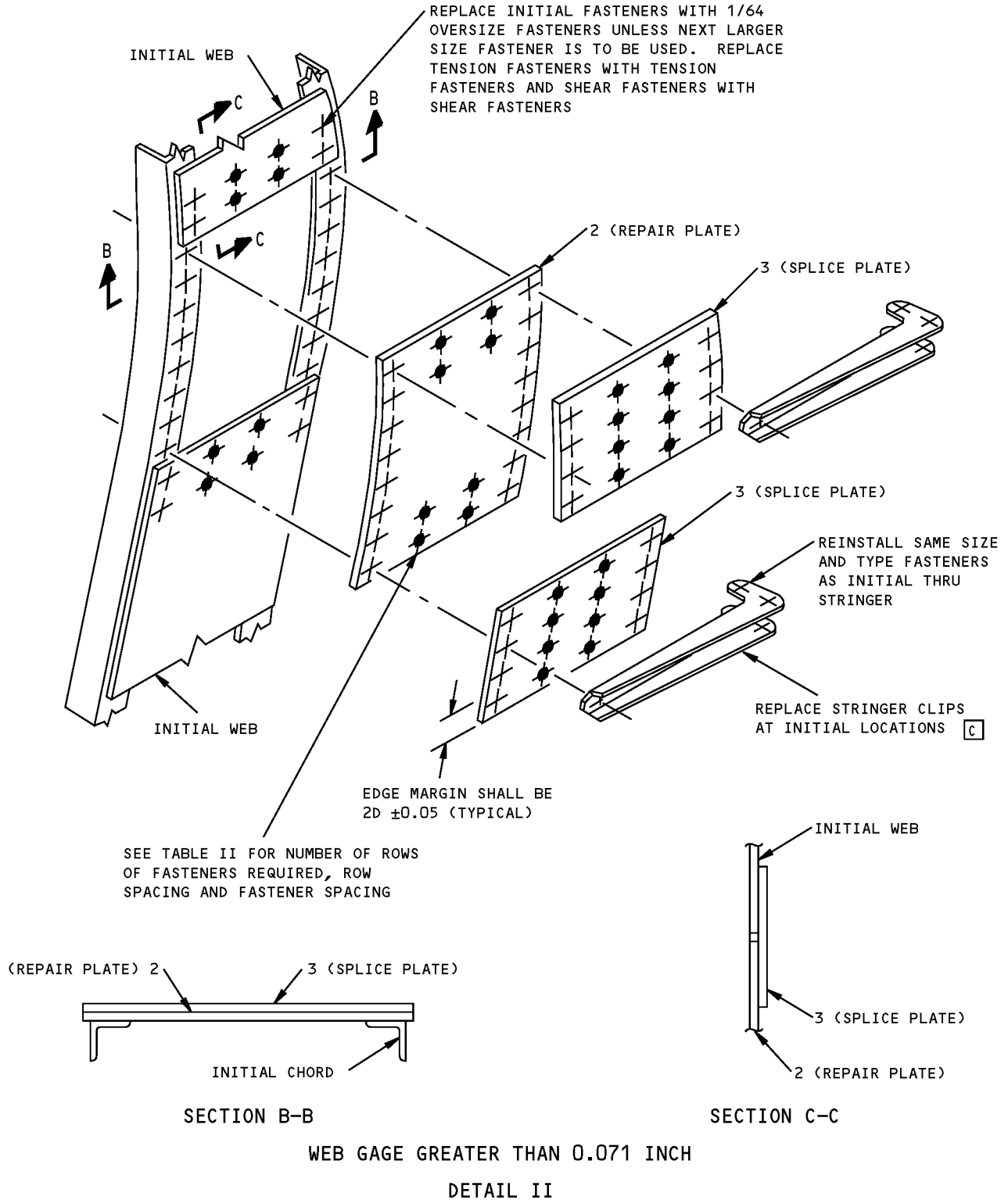


WEB GAGE 0.071 INCH OR LESS

DETAIL I

**Fuselage Built-Up Frame Web Repair - 757-SF
Figure 201 (Sheet 2 of 3)**

STRUCTURAL REPAIR MANUAL



Fuselage Built-Up Frame Web Repair - 757-SF
Figure 201 (Sheet 3 of 3)

STRUCTURAL REPAIR MANUAL

REPAIR 5 - FUSELAGE LOWER LOBE FRAME REPAIRS IN THE FORWARD AND AFT CARGO COMPARTMENTS

APPLICABILITY
<p>THESE REPAIRS ARE APPLICABLE TO PASSENGER MODELS ONLY.</p> <p>THESE REPAIRS (DETAILS I THROUGH III) ARE ONLY APPLICABLE TO FRAME INNER CHORD AND WEB DAMAGE IN THE FOLLOWING AREAS (EXCLUDING THE CARGO DOOR CUTOUT EDGE FRAMES):</p> <ul style="list-style-type: none"> - FORWARD CARGO COMPARTMENT BS 580 TO BS 840, BETWEEN THE CARGO DECK AND THE SIDEWALL STANCHION, RIGHT AND LEFT EXCEPT Q. - AFT CARGO COMPARTMENT BS 1320 TO BS 1620, BETWEEN THE CARGO DECK AND THE SIDEWALL STANCHION, RIGHT AND LEFT. - FOR AIRPLANES WITH NO. 3 CARGO DOOR: AFT CARGO COMPARTMENT BS 1320 TO BS 1480, BETWEEN THE CARGO DECK AND THE SIDEWALL STANCHION, RIGHT AND LEFT. - THE END FASTENER OF THE REPAIR CANNOT BE MORE THAN 6 INCHES OUTSIDE THE ABOVE DEFINED AREA. <p>REFER TO DETAIL I IF THE DAMAGE CUTOUT IS AT THE INNER CHORD ONLY AND AWAY FROM A SPLICE. REFER TO DETAIL II IF THE DAMAGE IS AT THE INNER CHORD AND WEB, AWAY FROM A SPLICE. HOWEVER, IT IS RECOMMENDED TO USE DETAIL I INSTEAD OF THE DETAIL II REPAIR, IF POSSIBLE, TO PREVENT REPLACEMENT OF STRINGER CLIPS AND OTHER STRUCTURE AT THE INTERFACE. REFER TO DETAIL III IF THE DAMAGE CUTOUT IS NEAR A PRODUCTION SPLICE.</p> <p>THE TABLE II INSPECTIONS ARE AN ALTERNATIVE METHOD OF COMPLIANCE (AMOC) FOR THE INSPECTIONS DEFINED BY SUBSECTION B OF BOEING DOCUMENT D622N001-9 (REFERENCE MPD SECTION 9, SSI 53-30-24 AND 53-60-24; MPD SECTION 8, 53-372-00) AT THE DETAIL II AND III REPAIR LOCATIONS, REQUIRED BY PARAGRAPH (H) AND (I) OF AD 2006-11-11.</p> <p>THE REPAIR GIVEN IN DETAIL I WILL NOT HAVE AN AFFECT ON THE INSPECTIONS THAT ARE NECESSARY FOR AD 2006-11-11 AND MPD ITEM 53-372-00.</p>

REPAIR INSTRUCTIONS

1. Trim out the frame inboard flange and web as necessary to remove all of the damage. Keep 0.5 inch minimum corner radius and 2D edge margin on the initial fasteners.
2. Do a High Frequency Eddy Current (HFEC) inspection of the edge of the cutout. If no cracks are found make the cutout larger by 0.04 inch as an insurance cut. Keep 125 microinches Ra roughness or smoother on the edges of the cutout. Refer to 757 NDT, Part 6, 51-00-01.

3. Do a High Frequency Eddy Current (HFEC) inspection of all initial fastener holes that will be common to the repair. Refer to 757 NDT, Part 6, 51-00-16.
 4. Make the repair parts. See Table I, Details I thru III as applicable. **D J**
- NOTE: For repairs given in Details II and III, a new repair stringer clip part 4 is necessary where the repair displaces the initial stringer clips.
5. Apply a chemical conversion coating to all bare initial aluminum and repair parts. Refer to SRM 51-20-01.
 6. Apply two coats of BMS 10-11, Type I primer to all bare initial aluminum and repair parts. Refer to SOPM 20-41-02.
 7. Drill the repair fasteners holes. Keep 4D to 6D spacing and a minimum 2D edge margins on all repair fasteners. Adjust the repair fastener pattern to keep a 2D minimum spacing from the repair fasteners to the plugged holes and 4D to the initial fasteners.

CAUTION: FOR FRAMES LESS THAN 0.063 INCH THICK USE A BACKING PLATE OF 0.125 INCH THICK, 7075-T6 CLAD MATERIAL AGAINST THE INNER CHORD AND WEB. THIS PROCEDURE IS NECESSARY TO PREVENT VOLCANO EFFECTS AT THE FASTENER HOLES DUE TO RELATIVELY THIN GAGES.

8. High interference cold work the end repair fastener holes in the inner chord and web as shown in Details I thru III. Refer to SRM 51-40-09, Figure 2.
- NOTE: A volcano effect is the circumferential protrusion of material around a hole. Contact The Boeing Company if this damage occurs.
9. Shim all gaps more than 0.010 inch up to a maximum of 0.040 inch before you install fasteners. Contact The Boeing Company with details of gaps more than 0.040 inch. Refer to SRM 51-30-01.
 10. Assemble the repair parts with BMS 5-95 sealant between the mating surfaces. Refer to SRM 51-20-05.
 11. Install the fasteners. Install all hex-drive bolts wet with BMS 5-95 sealant in transition holes. Refer to SRM 51-40.
 12. Apply BMS 3-23, or an equivalent corrosion inhibiting compound, to the internal surfaces of the repair area. Refer to SRM 51-20-01.

**Fuselage Lower Lobe Frame Repairs in the Forward and Aft Cargo Compartments
Figure 201 (Sheet 1 of 15)**

STRUCTURAL REPAIR MANUAL

NOTES






- THESE REPAIRS (DETAILS I THRU III) ARE CATEGORY B REPAIRS. THE CATEGORY B REPAIR HAS FAA APPROVAL IF YOU DO THE SUPPLEMENTAL INSPECTIONS AS GIVEN IN TABLE II. INCORPORATION OF THESE INSPECTION REQUIREMENTS INTO THE AIRPLANE'S MAINTENANCE PROGRAM SATISFIES THE DAMAGE TOLERANCE ASSESSMENT OF THE REPAIR. REFER TO SRM 51-00-06 FOR THE REPAIR CATEGORIES.
- THE REPAIRS AS GIVEN IN DETAILS II AND III WILL HAVE AN EFFECT ON THE INSPECTIONS OF THE MAINTENANCE PLANING DATA (MPD) ITEM 53-372-00. THE INSPECTIONS AS GIVEN IN TABLE II WILL MEET THE INSPECTION REQUIREMENTS FOR THESE STRUCTURAL SIGNIFICANT ITEMS (SSI) IN THE MPD AND AD 2006-11-11. CONTINUE WITH THE MPD AND AD 2006-11-11 INSPECTIONS FOR DETAIL I REPAIR.
- D = FASTENER DIAMETER
- BREAK ALL SHARP EDGES OF THE INITIAL AND REPAIR PARTS TO 0.015 TO 0.030 INCH.
- REMOVE ALL NICKS, SCRATCHES, BURRS, SHARP EDGES AND CORNERS FROM THE INITIAL AND REPAIR PARTS
- WHEN YOU USE THIS REPAIR REFER TO:
 - SOPM 20-41-02 FOR APPLICATION OF CHEMICAL AND SOLVENT RESISTANT FINISHES
 - SRM 51-10-02 FOR INSPECTION AND REMOVAL OF DAMAGE
 - SRM 51-20-01 FOR PROTECTIVE TREATMENT OF METALLIC AND NON-METALLIC MATERIALS
 - SRM 51-20-05 FOR REPAIR SEALING
 - SRM 51-30-01 FOR SHIMMING AND MINIMUM BEND RADII
 - SRM 51-40 FOR FASTENER CODE, INSTALLATION AND REMOVAL, HOLE SIZES, EDGE MARGINS AND SUBSTITUTION.
 - SRM 51-40-09 FOR HIGH INTERFERENCE COLD WORK OF THE HOLES.
 - NDT, PART 6, 51-00-01 FOR SURFACE CRACK INSPECTION.
 - NDT, PART 6, 51-00-16 FOR OPEN HOLE INSPECTION.



- A** ONE GAGE THICKER THAN THE INITIAL FRAME THICKNESS.
- B** SAME GAGE AS THE INITIAL FRAME.
- C** SAME MATERIAL AND GAGE AS THE INITIAL PART.
- D** REFER TO SRM 51-30-01 FOR MINIMUM BEND RADIUS.
- E** MAKE THE REPAIR ANGLE TO EXTEND FIVE REPAIR ROWS MINIMUM ON EACH SIDE OF THE CHORD CUTOUT.
- F** MAKE THE REPAIR PART TO EXTEND ONE FASTENER ROW BELOW THE CHORD CUTOUT.
- G** DO NOT EXTEND THE REPAIR ANGLE ONTO THE FRAME FAIL SAFE CHORD.
- H** THE END FASTENER HOLES MUST NOT COINCIDE WITH THE INITIAL FASTENER HOLES, TOOLING HOLES, OR INSULATION BLANKET ATTACHMENT HOLES SO THAT THE SUPPLEMENTAL INSPECTION THRESHOLD CAN BE BASED ON FLIGHT CYCLES AFTER REPAIR INSTALLATION. EXTEND REPAIR AS REQUIRED TO INSTALL THE END FASTENER AT A NEW LOCATION.
- I** THE REPAIR CAN END NEAR THE PRODUCTION SPLICE BUT THE END FASTENER MUST BE A MINIMUM OF 2 INCHES AWAY FROM THE END FASTENER OF THE INITIAL SPLICE PLATE
- J** HEAT TREAT THE REPAIR PART TO T6 CONDITION AFTER YOU FORM IT.
- K** REPLACE THESE FASTENERS WITH BACB30NX(K)Y (SECOND OVERSIZE FROM THE INITIAL SIZE).
- L** HIGH INTERFERENCE COLD WORK THESE REPAIR FASTENER HOLES AS GIVEN IN SRM 51-40-09.
- M** SEE DETAILS IV AND V FOR ZONE DEFINITION. INSPECTION REQUIREMENTS ARE BASED ON THE ZONE WHERE THE REPAIR END FASTENERS ARE LOCATED. THE LOWEST THRESHOLD AND INTERVAL OF EITHER END FASTENERS APPLIES TO THE ENTIRE REPAIR.
- N** MAKE SAME AS INITIAL PART, EXCEPT EXTEND BEYOND DAMAGE CUTOUT AS GIVEN IN DETAIL III.
- O** BS 680 FRAME REPAIRS WITH THE REPAIR SECTION ENDING ABOVE S-22, RIGHT AND LEFT, ARE CATEGORY C REPAIRS AND MUST BE REPLACED WITHIN 24 MONTHS, NOT TO EXCEED 3,000 FLIGHT CYCLES.

**Fuselage Lower Lobe Frame Repairs in the Forward and Aft Cargo Compartments
Figure 201 (Sheet 2 of 15)**

757-200 STRUCTURAL REPAIR MANUAL

FASTENER SYMBOLS

-  REFERENCE FASTENER LOCATION.
-  INITIAL BACR15FT6D FASTENER LOCATION. INSTALL BACB30NX6K()Y HEX-DRIVE BOLT WITH BACC30AC COLLAR IN TRANSITION FIT HOLE. IF YOU PICK UP AN INITIAL FASTENER LOCATION WHERE A TENSION HEAD HEX-DRIVE BOLT WAS INSTALLED, REPLACE IT WITH THE SAME TYPE BUT 1/64 INCH OVERSIZE BOLT.
-  INITIAL BACB30UB6K FASTENER LOCATION. INSTALL BACB30NX6K()X HEX-DRIVE BOLT WITH BACC30BH COLLAR IN TRANSITION FIT HOLE.
-  INITIAL BACB30UB8K FASTENER LOCATION. INSTALL BACB30NX8K()X HEX-DRIVE BOLT WITH BACC30BH COLLAR IN TRANSITION FIT HOLE.
-  INITIAL FASTENER LOCATION. K

-  REPAIR FASTENER LOCATION. INSTALL BACB30MY6K HEX-DRIVE BOLT WITH BACC30M COLLAR IN TRANSITION FIT HOLE.
-  TOOLING HOLE OR COORDINATION HOLE ("K" HOLE) LOCATION.

IT IS ACCEPTABLE TO USE THE TOOLING HOLES AND INSULATION BLANKET ATTACHMENT HOLES AS REPAIR FASTENER LOCATIONS. INSTALL A BACB30MY8K()Y HEX-DRIVE BOLT IN TRANSITION FIT HOLES AT THESE LOCATIONS. IF THESE HOLES ARE NOT USED, LIGHTLY COUNTERSINK THE HOLE TO 0.01 OR 0.02 INCH DEEP ON THE SIDE OF THE FRAME WHERE THE REPAIR ANGLE WILL BE INSTALLED. INSTALL A BACR15CE()AD() RIVET AND MICROSHAVE FLUSH. PLUGGED HOLES MUST HAVE A 2D MINIMUM SPACING FROM REPAIR FASTENER HOLES.

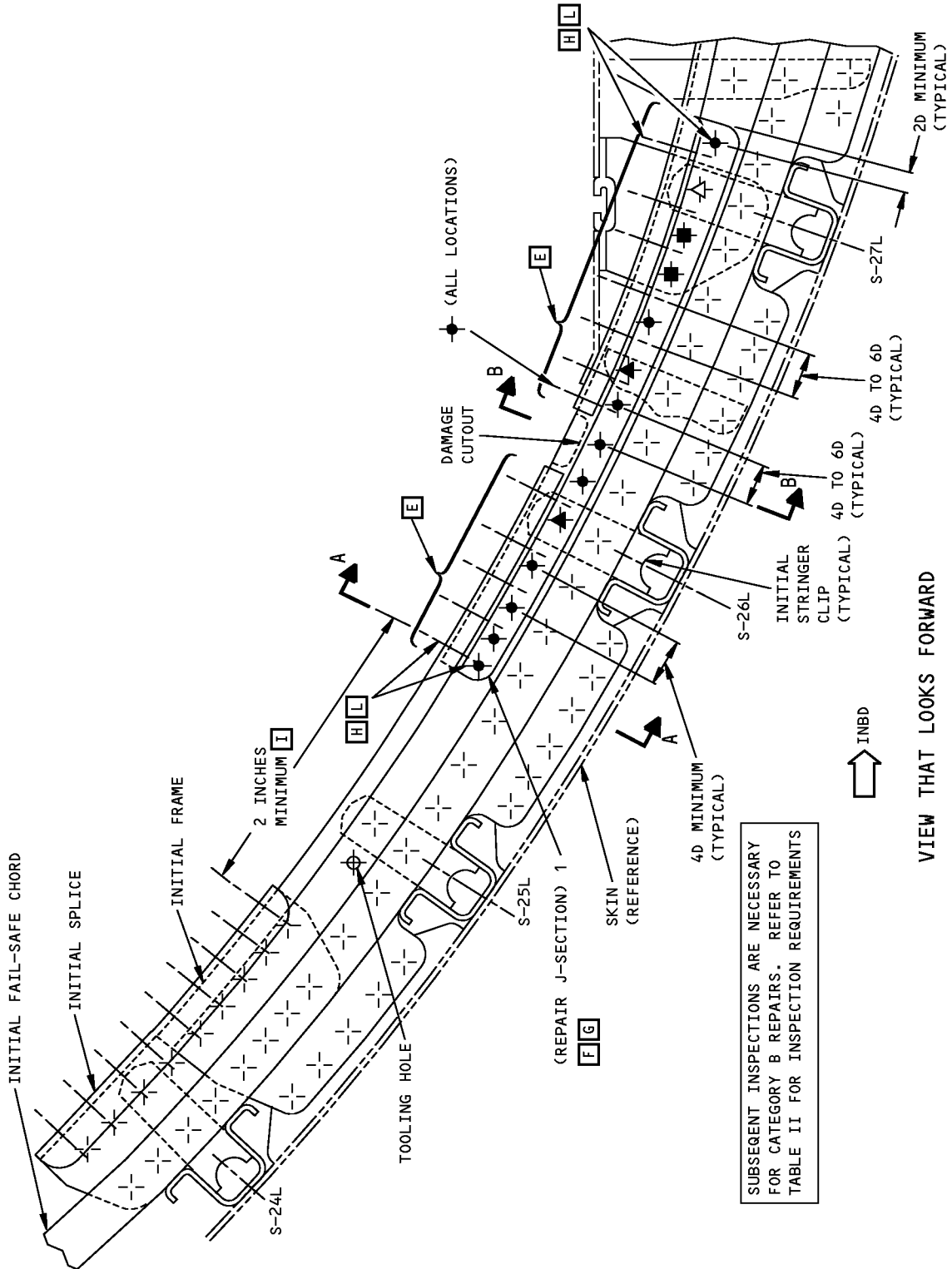
FILL THE COORDINATION HOLES ("K" HOLE) IN THE REPAIR AREA. LIGHTLY COUNTERSINK THE HOLE TO 0.01 OR 0.02 INCH DEEP ON THE SIDE OF THE FRAME WHERE THE REPAIR ANGLE WILL BE INSTALLED. INSTALL A BACR15DS9D() RIVET AND MICROSHAVE FLUSH. PLUGGED HOLES MUST HAVE 2D MINIMUM SPACING FROM REPAIR FASTENER HOLES.

REPAIR MATERIAL			
ITEM	PART	QTY	MATERIAL
1	REPAIR J-SECTION	1	7075-0 CLAD SHEET A J
2	REPAIR J-SECTION	1	7075-0 CLAD SHEET B J
3	REPAIR SPLICE	1	C N
4	REPAIR STRINGER CLIP	AS REQUIRED	C

TABLE I

Fuselage Lower Lobe Frame Repairs in the Forward and Aft Cargo Compartments Figure 201 (Sheet 3 of 15)

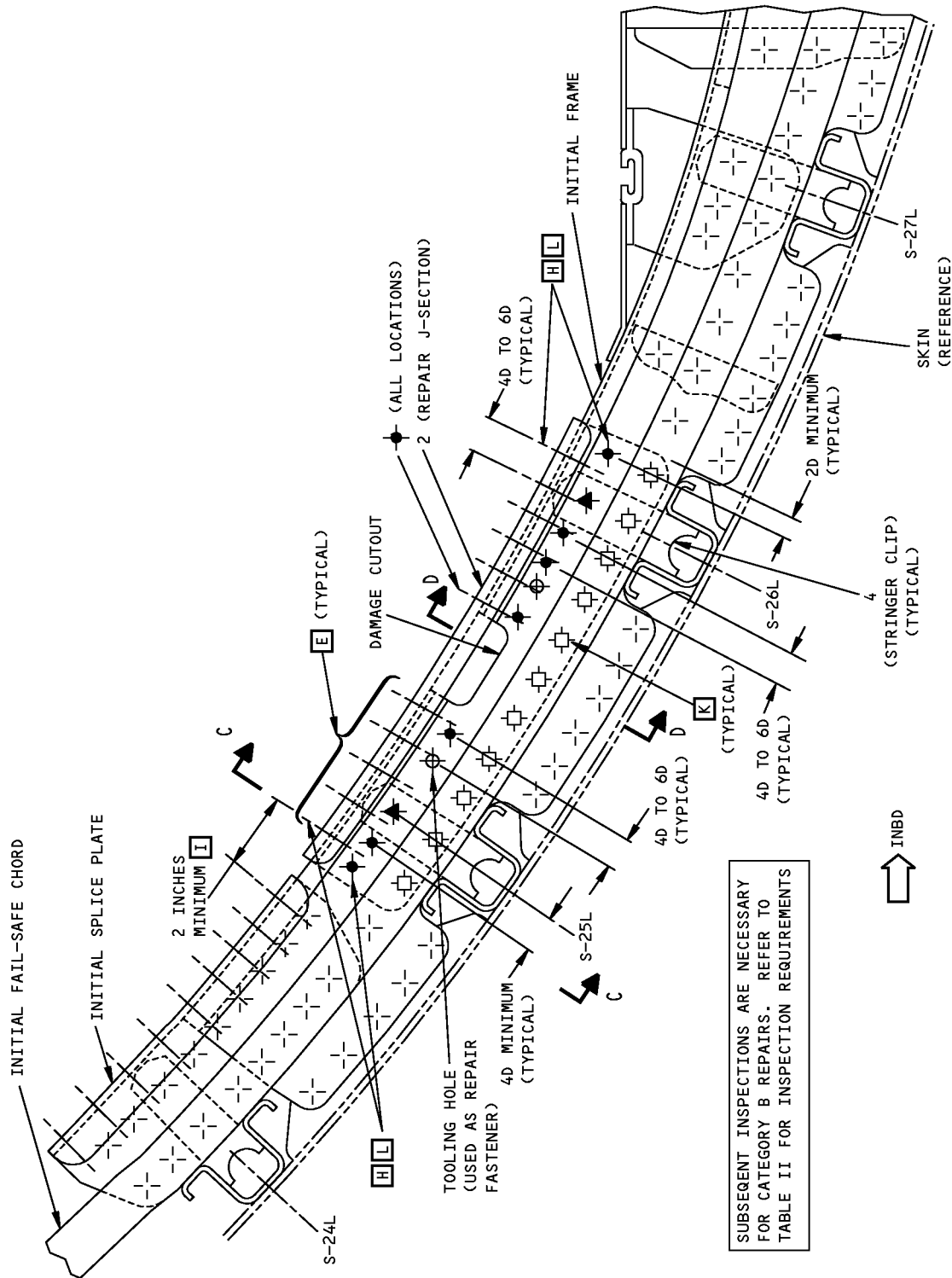
**757-200
STRUCTURAL REPAIR MANUAL**



**Fuselage Lower Lobe Frame Repairs in the Forward and Aft Cargo Compartments
Figure 201 (Sheet 4 of 15)**

VIEW THAT LOOKS FORWARD
(STATION 1380 FRAME IS SHOWN, ALMOST THE SAME AT OTHER CARGO FRAMES)
REPAIR FOR DAMAGE AT THE INNER CHORD AND AWAY FROM THE PRODUCTION SPLICE
DETAIL 1

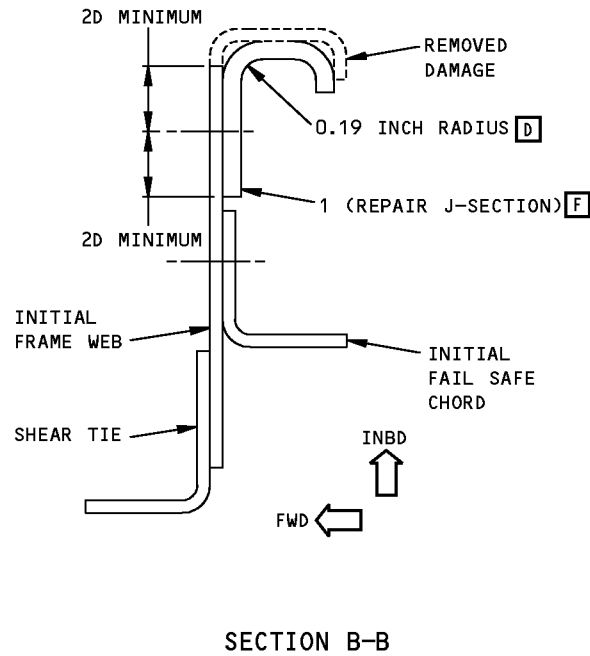
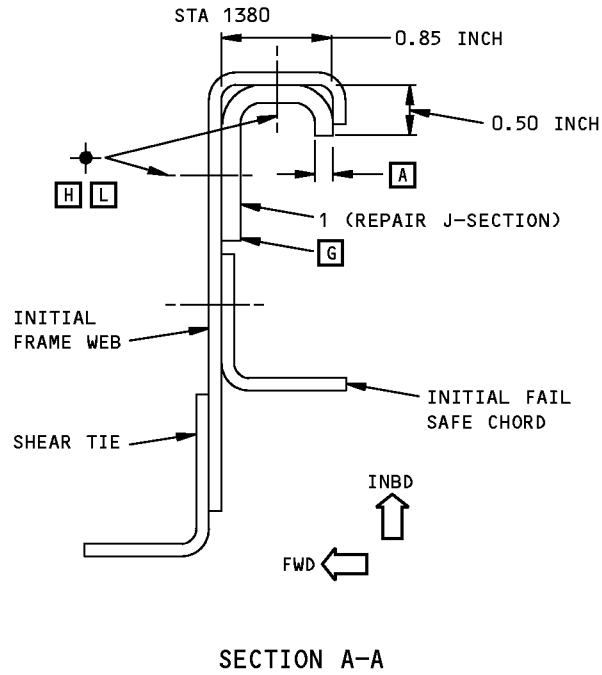
**757-200
STRUCTURAL REPAIR MANUAL**



VIEW THAT LOOKS FORWARD
REPAIR FOR DAMAGE CUTOUT AT THE INNER CHORD AND FRAME WEB AWAY FROM THE PRODUCTION SPLICE
DETAIL II

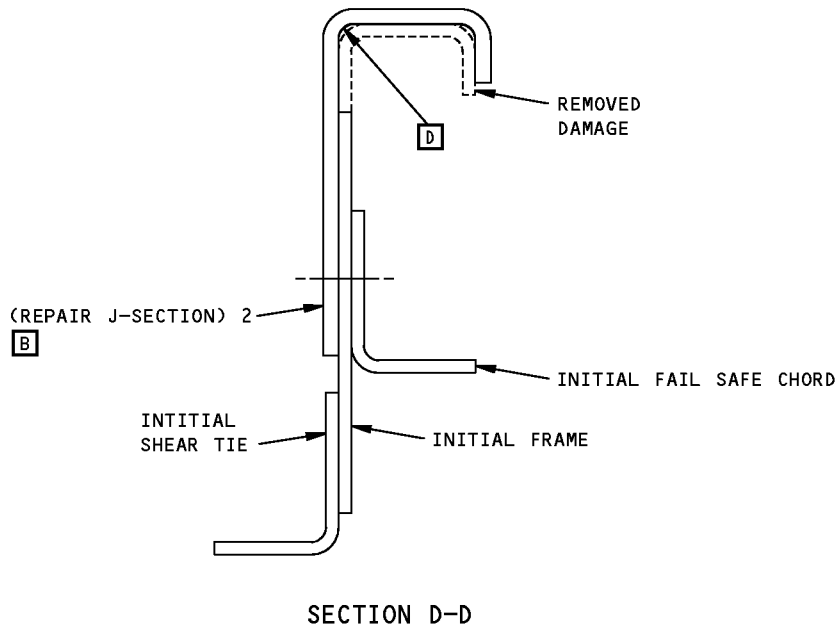
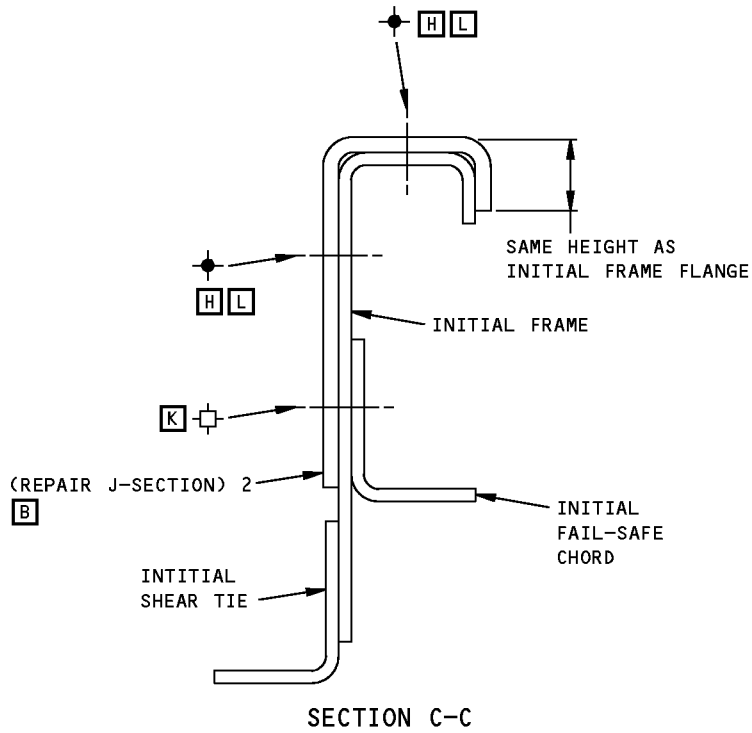
**Fuselage Lower Lobe Frame Repairs in the Forward and Aft Cargo Compartments
Figure 201 (Sheet 5 of 15)**

**757-200
STRUCTURAL REPAIR MANUAL**



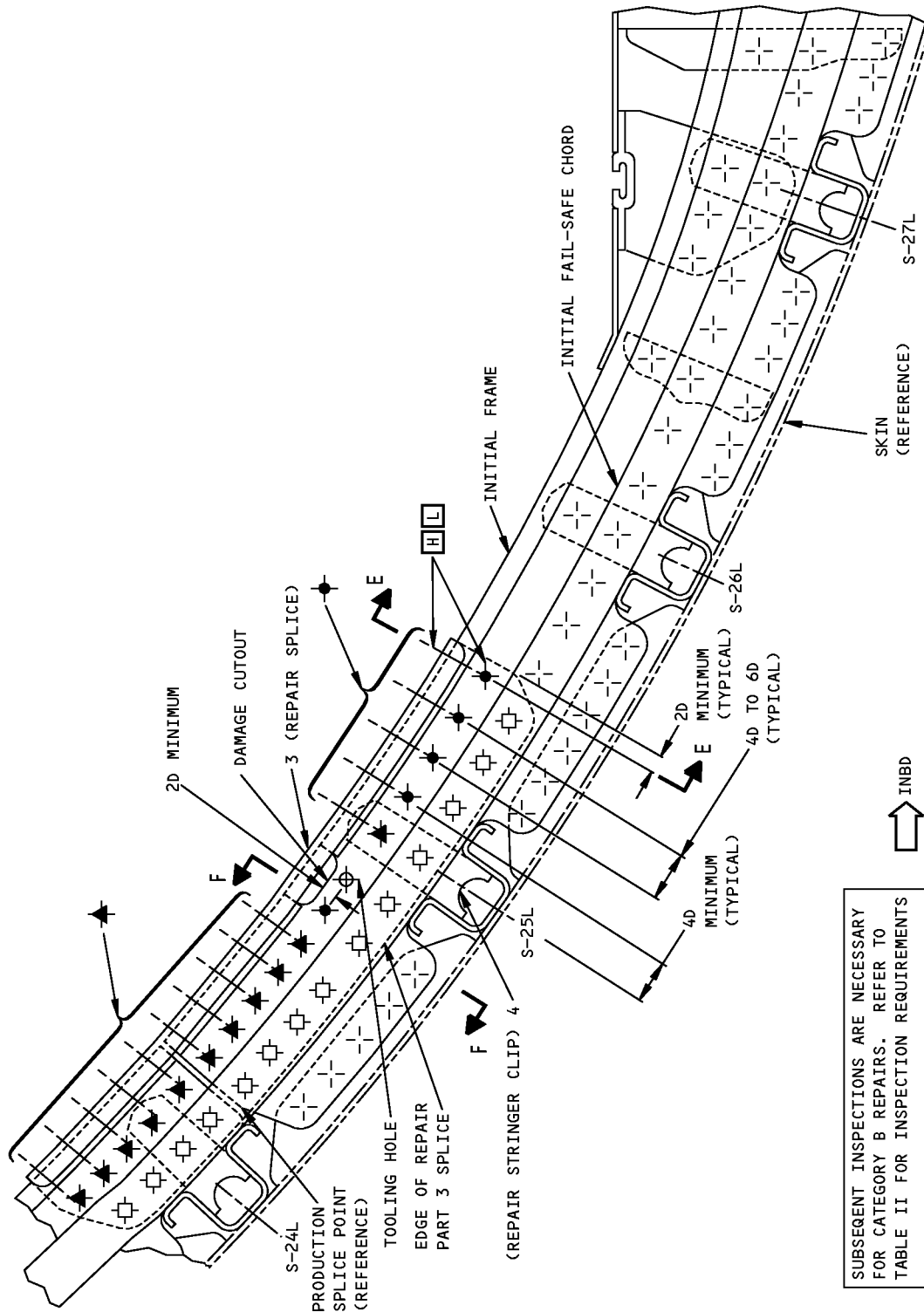
**Fuselage Lower Lobe Frame Repairs in the Forward and Aft Cargo Compartments
Figure 201 (Sheet 6 of 15)**

**757-200
STRUCTURAL REPAIR MANUAL**



**Fuselage Lower Lobe Frame Repairs in the Forward and Aft Cargo Compartments
Figure 201 (Sheet 7 of 15)**

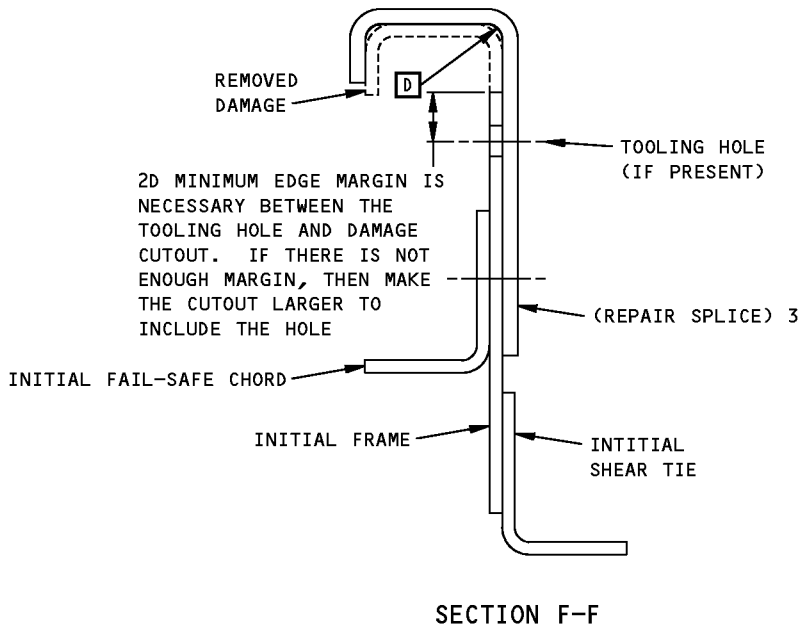
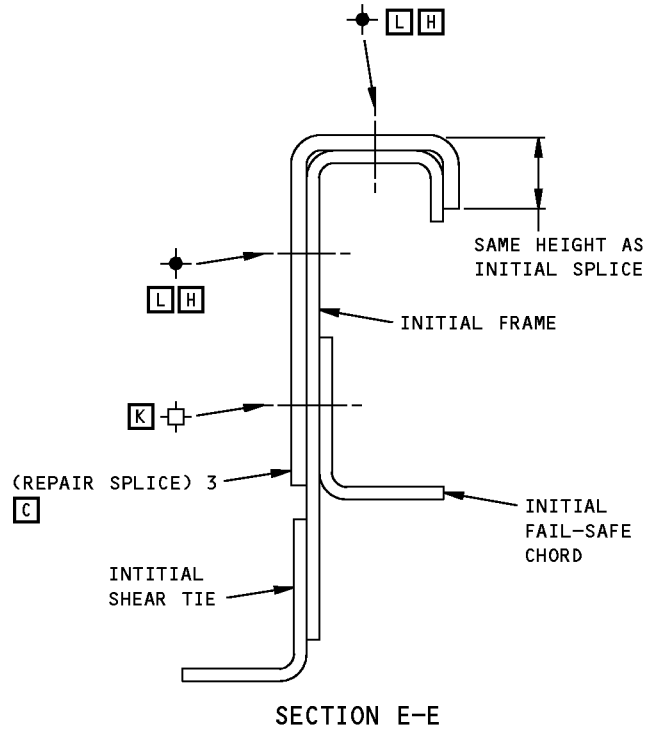
**757-200
STRUCTURAL REPAIR MANUAL**



VIEW THAT LOOKS FORWARD
 (STATION 1400 FRAME IS SHOWN, ALMOST THE SAME FOR OTHER FRAMES)
 REPAIR FOR DAMAGE NEAR THE PRODUCTION SPLICE
 DETAIL III

**Fuselage Lower Lobe Frame Repairs in the Forward and Aft Cargo Compartments
 Figure 201 (Sheet 8 of 15)**

**757-200
STRUCTURAL REPAIR MANUAL**



**Fuselage Lower Lobe Frame Repairs in the Forward and Aft Cargo Compartments
Figure 201 (Sheet 9 of 15)**

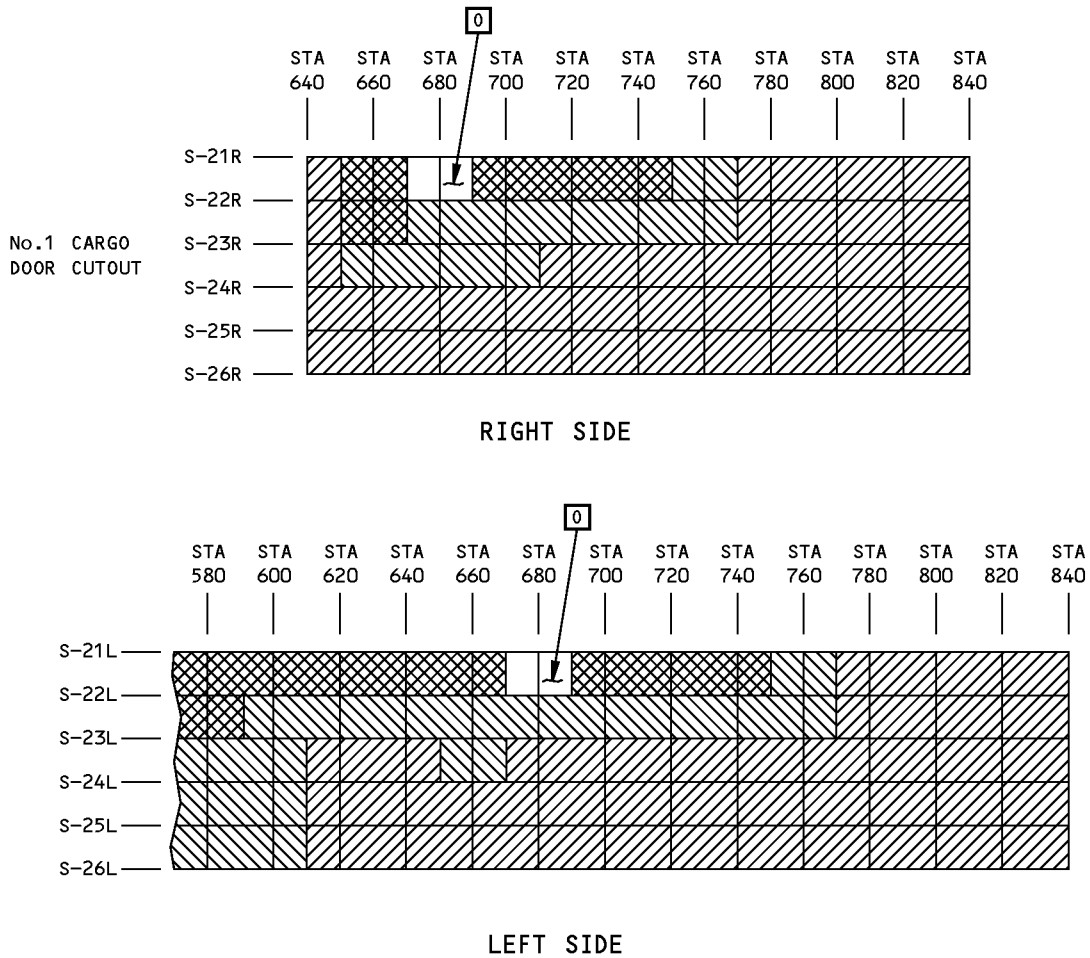
**757-200
STRUCTURAL REPAIR MANUAL**

CATEGORY B INSPECTION REQUIREMENTS			
INSPECTION THRESHOLD	REPEAT INSPECTIONS		
	METHOD	INTERVAL	REFERENCE
ZONE 1 M 37,500 FLIGHT CYCLES AFTER REPAIR INSTALLATION OR 50,000 AIRFRAME FLIGHT CYCLES, WHICHEVER COMES FIRST H	HIGH FREQUENCY EDDY CURRENT (HFEC)	12,000 FLIGHT CYCLES	NDT, PART 6, 51-00-01
	DETAILED INSPECTION	12,000 FLIGHT CYCLES	
ZONE 2 M 25,000 FLIGHT CYCLES AFTER REPAIR INSTALLATION OR 50,000 AIRFRAME FLIGHT CYCLES, WHICHEVER COMES FIRST H	HIGH FREQUENCY EDDY CURRENT (HFEC)	11,000 FLIGHT CYCLES	NDT, PART 6, 51-00-01
	DETAILED INSPECTION	11,000 FLIGHT CYCLES	
ZONE 3 M 12,000 FLIGHT CYCLES AFTER REPAIR INSTALLATION OR 50,000 AIRFRAME FLIGHT CYCLES, WHICHEVER COMES FIRST H	HIGH FREQUENCY EDDY CURRENT (HFEC)	11,000 FLIGHT CYCLES	NDT, PART 6, 51-00-01
	DETAILED INSPECTION	11,000 FLIGHT CYCLES	
NOTE: - INSPECT THE INITIAL FRAME IN THE REPAIRED AREA WITH HFEC METHOD AS SHOWN IN DETAILS VI, VII AND VIII AS APPLICABLE. - DO A DETAILED INSPECTION OF THE INITIAL FRAME COMMON TO THE REPAIR SECTION AS SHOWN IN DETAILS VI, VII, AND VIII. ALSO DO A DETAILED INSPECTION OF THE TWO ADJACENT FRAMES ON EACH SIDE (TOTAL OF FOUR FRAMES) OF THE REPAIRED FRAME (FROM ONE STRINGER ABOVE TO ONE STRINGER BELOW THE REPAIR SECTION). - CONTINUE WITH THE MPD ITEM 53-372-00 INSPECTIONS IN ALL AREAS BEYOND THE REPAIR.			

TABLE II

**Fuselage Lower Lobe Frame Repairs in the Forward and Aft Cargo Compartments
Figure 201 (Sheet 10 of 15)**

**757-200
STRUCTURAL REPAIR MANUAL**

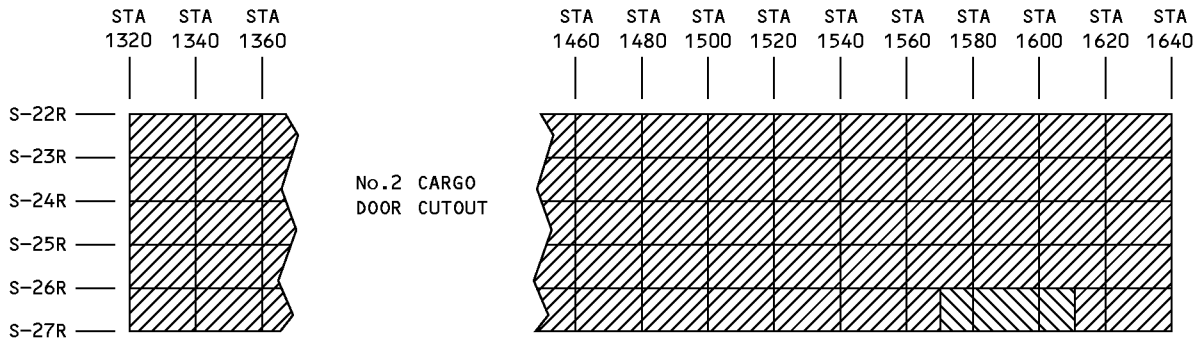


- ZONE 1 M
- ZONE 2 M
- ZONE 3 M

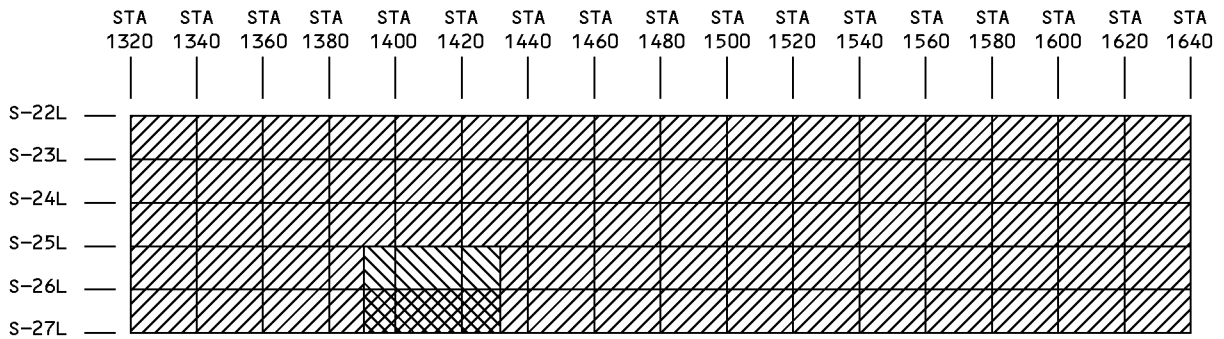
**FORWARD CARGO COMPARTMENT
SUPPLEMENTAL INSPECTION ZONES
DETAIL IV**

**Fuselage Lower Lobe Frame Repairs in the Forward and Aft Cargo Compartments
Figure 201 (Sheet 11 of 15)**

**757-200
STRUCTURAL REPAIR MANUAL**



RIGHT SIDE



LEFT SIDE

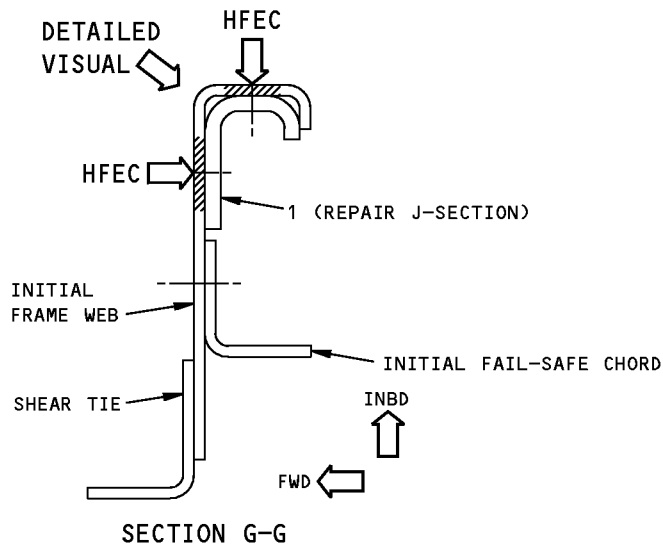
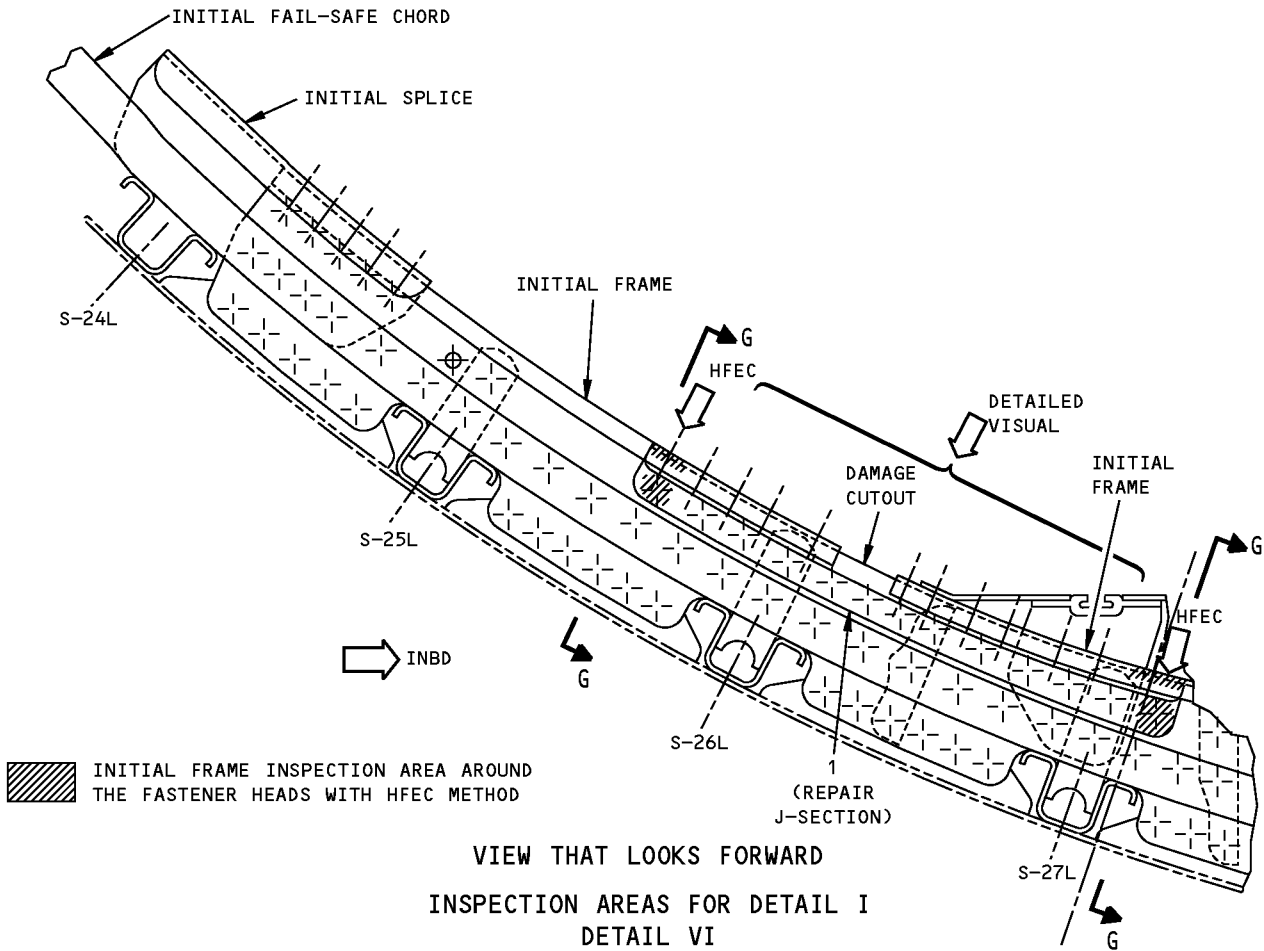
- ZONE 1 M
- ZONE 2 M
- ZONE 3 M

**AFT CARGO COMPARTMENT
SUPPLEMENTAL INSPECTION ZONES**

DETAIL V

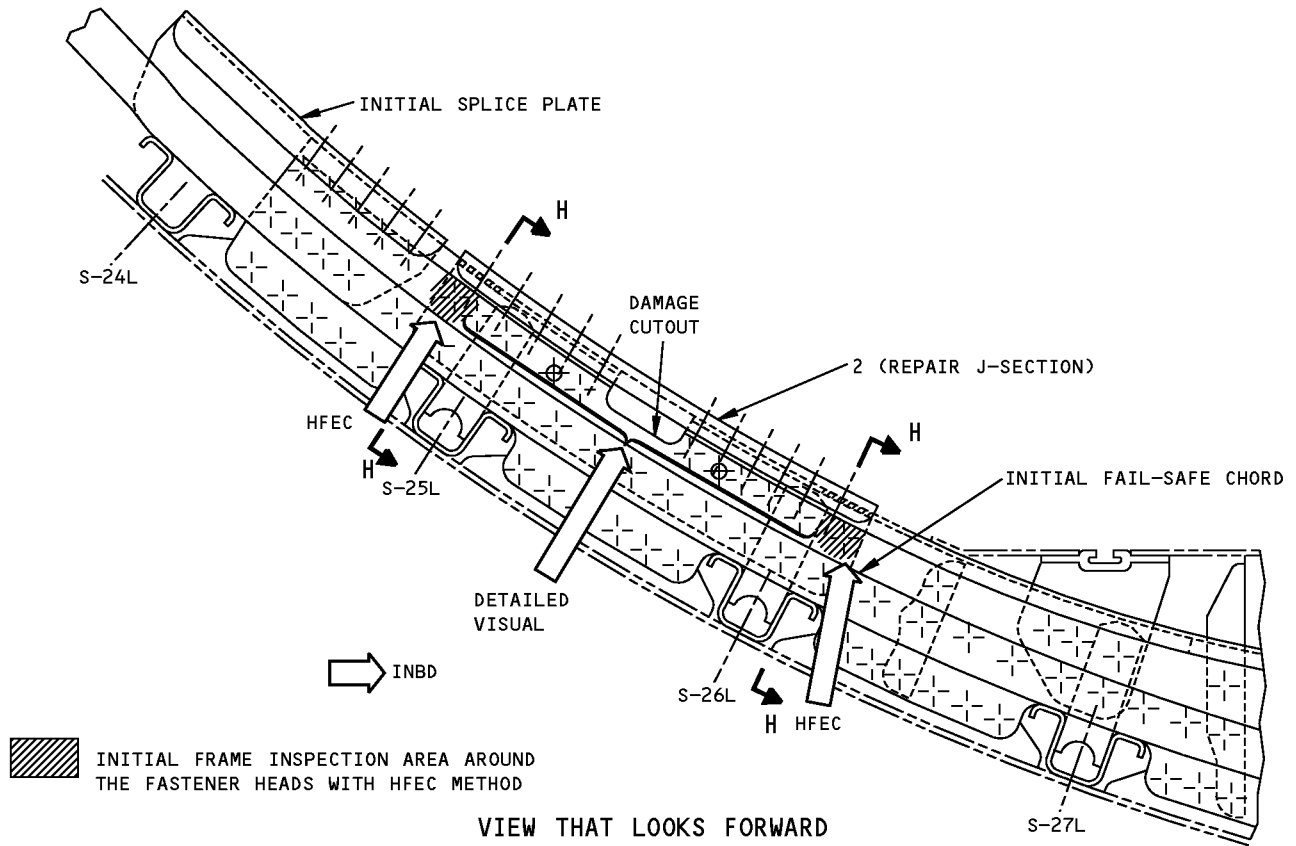
**Fuselage Lower Lobe Frame Repairs in the Forward and Aft Cargo Compartments
Figure 201 (Sheet 12 of 15)**

**757-200
STRUCTURAL REPAIR MANUAL**

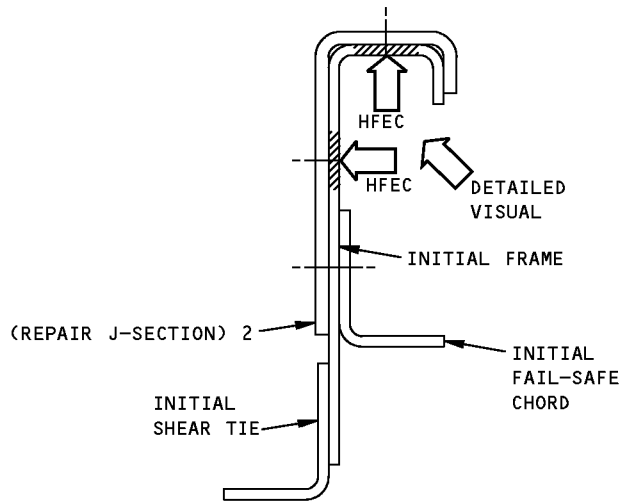


**Fuselage Lower Lobe Frame Repairs in the Forward and Aft Cargo Compartments
Figure 201 (Sheet 13 of 15)**

**757-200
STRUCTURAL REPAIR MANUAL**



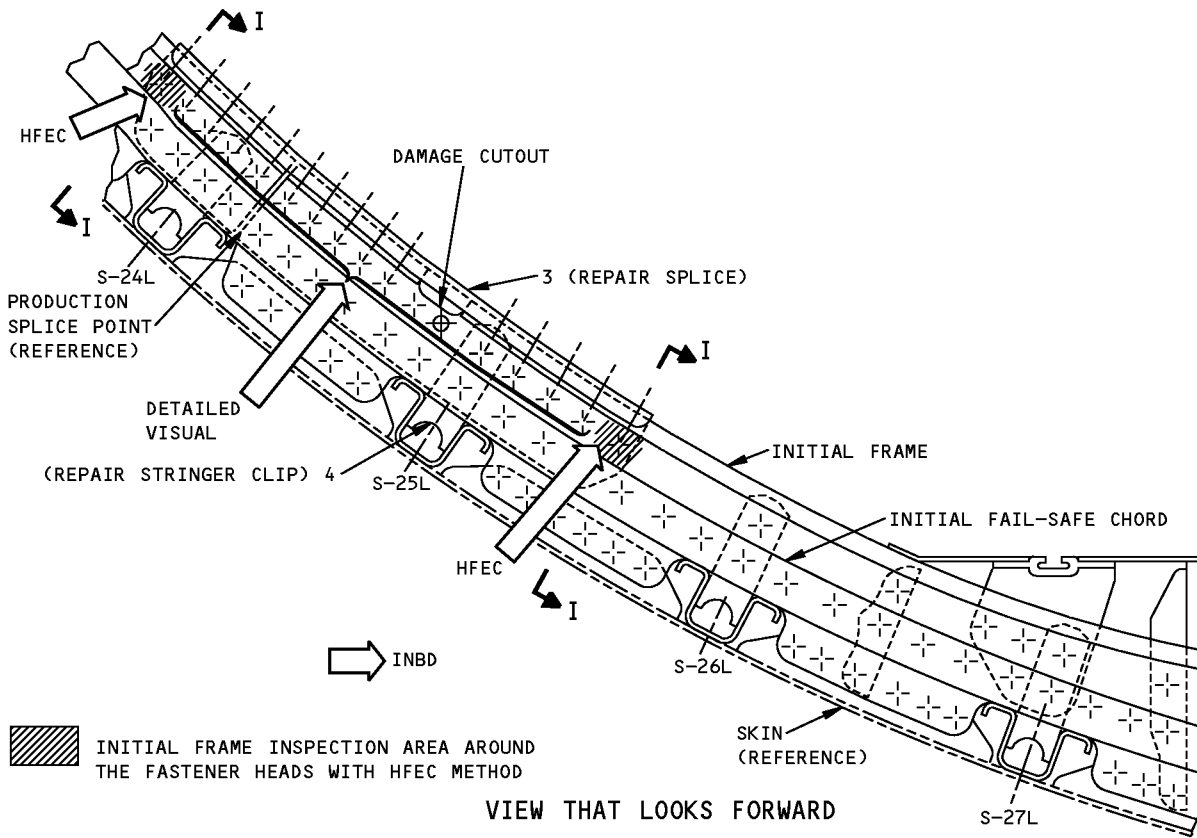
**VIEW THAT LOOKS FORWARD
INSPECTION AREAS FOR DETAIL II
DETAIL VII**



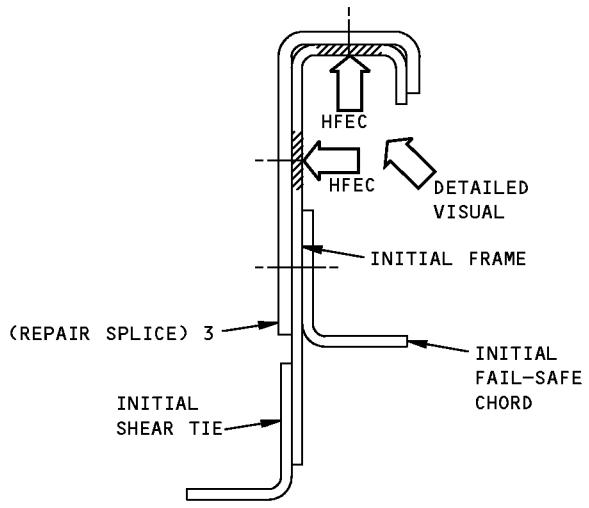
SECTION H-H

**Fuselage Lower Lobe Frame Repairs in the Forward and Aft Cargo Compartments
Figure 201 (Sheet 14 of 15)**

**757-200
STRUCTURAL REPAIR MANUAL**



VIEW THAT LOOKS FORWARD
INSPECTION AREAS FOR DETAIL III
DETAIL VIII

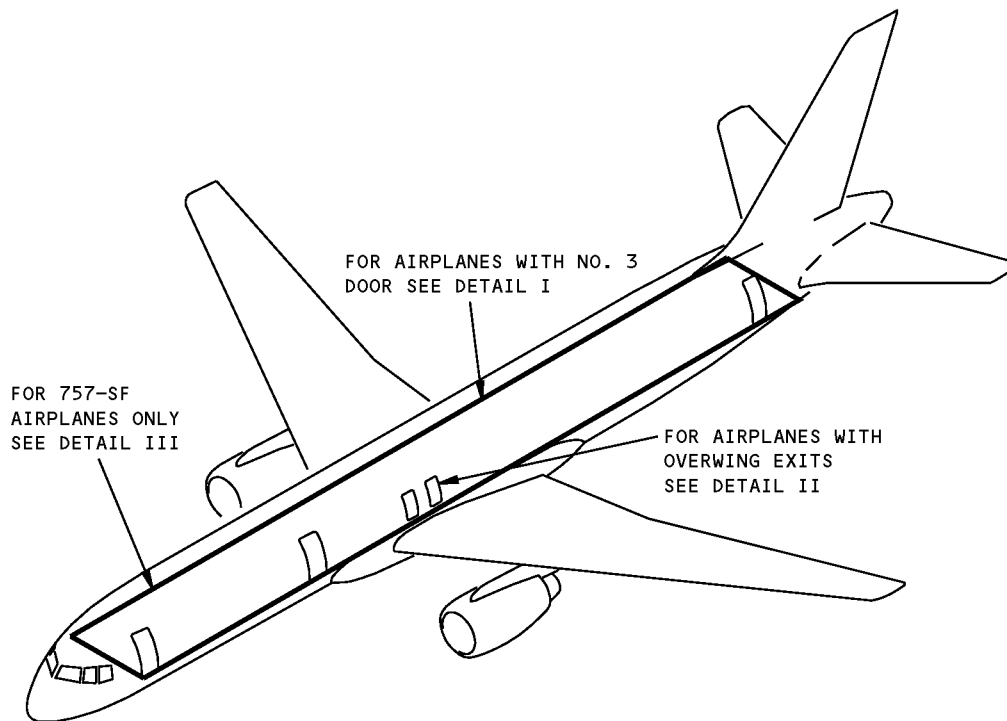


SECTION I-I

**Fuselage Lower Lobe Frame Repairs in the Forward and Aft Cargo Compartments
Figure 201 (Sheet 15 of 15)**

**757-200
STRUCTURAL REPAIR MANUAL**

IDENTIFICATION 1 - MAIN DECK FLOOR PANEL



NOTES

- THE FOLLOWING GROUND RULES HAVE BEEN USED FOR THE SELECTION OF FLOOR PANELS IN DESIGN. THE FLOOR PANEL ARRANGEMENT AND MATERIAL SELECTION, HOWEVER, REMAINS AS OPERATOR OPTIONS.
1. LOW DENSITY HONEYCOMB CORES (BOTH NOMEX AND ALUMINUM CORES) ARE USED IN LOW TRAFFIC AREA SUCH AS UNDER SEATS. LOW DENSITY NOMEX HONEYCOMB CORE IS USED UNDER LAVATORIES.
 2. MEDIUM DENSITY ALUMINUM HONEYCOMB CORES ARE USED IN SPECIAL CASES OF AREAS WITH HIGH LOADS NOT SUBJECT TO MOISTURE.
 3. MEDIUM AND DUAL DENSITY HONEYCOMB CORES (BOTH NOMEX AND ALUMINUM CORES) ARE USED IN HIGH TRAFFIC AREA SUCH AS IN AISLES.
 4. HIGH DENSITY NOMEX HONEYCOMB CORES ARE USED IN AREA OF HIGH LOADS SUBJECT TO MOISTURE SUCH AS IN GALLEYS AND IN THE VICINITY OF ENTRANCE DOORS.
- LAVATORY FLOOR INTEGRAL WITH MODULE
 - LAVATORY AND GALLEY LOCATIONS VARY AS AN OPERATOR OPTION
 - ONE PANEL INSIDE GALLEY MAY HAVE TITANIUM FACE SHEETS FOR CART WHEEL LOADS

- A** FLOOR PANELS VARY AS AN OPERATOR OPTION
- B** FIBERGLASS FACED NOMEX CORE BMS 4-17, TYPE I, GRADE B
- C** FIBERGLASS FACED NOMEX CORE BMS 4-17, TYPE II, GRADE B
- D** FIBERGLASS FACED NOMEX CORE BMS 4-17, TYPE III, GRADE B
- E** FIBERGLASS FACED NOMEX CORE BMS 4-17, TYPE VII, GRADE B
- F** FIBERGLASS FACED NOMEX CORE BMS 4-17, TYPE VI, GRADE B
 - REFER TO BOEING DRAWING 69B15779, TYPE VI
- G** FIBERGLASS FACED ALUMINUM CORE BMS 4-23, TYPE I
- H** FIBERGLASS FACED ALUMINUM CORE BMS 4-23, TYPE II
- I** FIBERGLASS FACED ALUMINUM CORE BMS 4-23, TYPE III
- J** FIBERGLASS FACED ALUMINUM CORE BMS 4-23, TYPE IV
- K** GALLEYS AND LAVATORIES ARE OPTIONAL IN THIS AREA

**Main Deck Floor Panel Identification
Figure 1 (Sheet 1 of 5)**



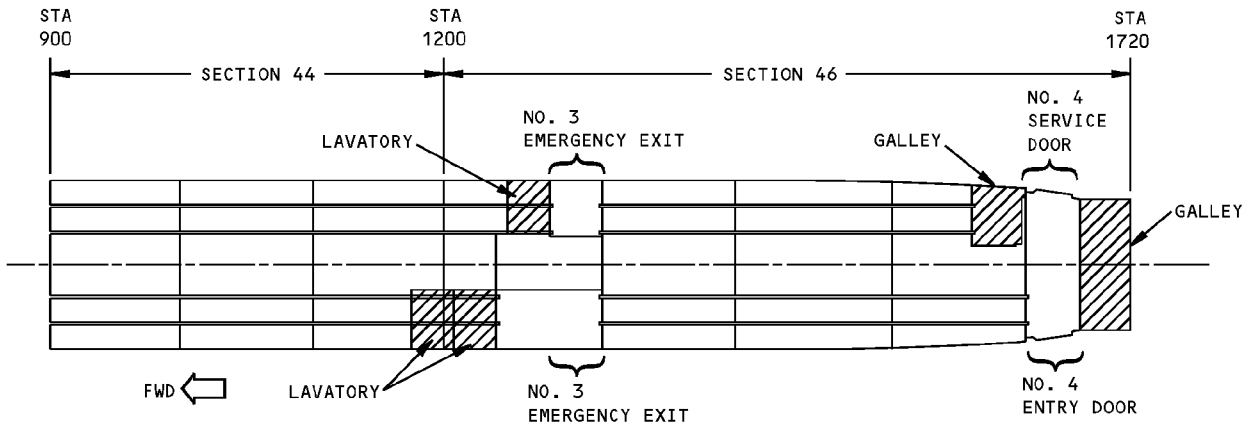
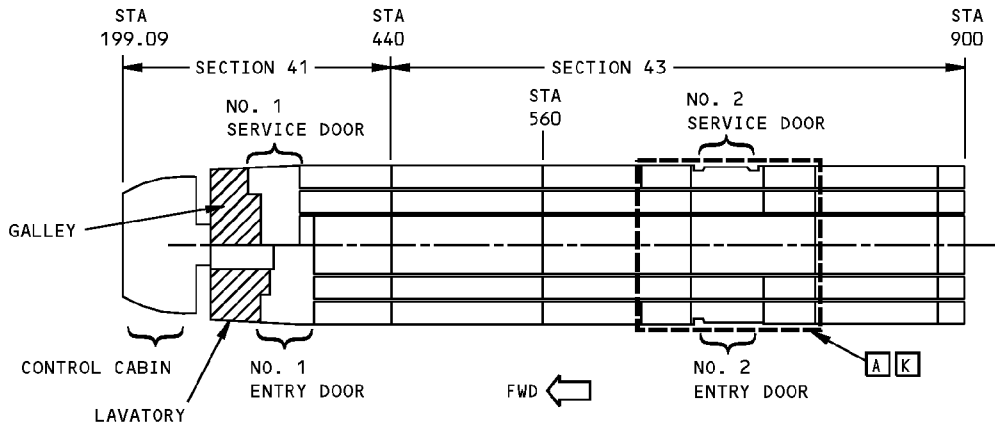
757-200

STRUCTURAL REPAIR MANUAL

PANEL MATERIAL	LOCATION					
	CONTROL CABIN	VICINITY OF DOORS	UNDER SEATS	AISLES AND TRAFFIC AREAS	UNDER GALLEYS	UNDER LAVATORIES
FIBERGLASS FACED NOMEX (LOW DENSITY CORE) B			•			•
FIBERGLASS FACED NOMEX (MEDIUM DENSITY CORE) C				•		
FIBERGLASS FACED NOMEX (MEDIUM DENSITY CORE) D				• OVER WING BOX		
FIBERGLASS FACED NOMEX (DUAL DENSITY CORE) E			•	•		
FIBERGLASS FACED NOMEX HONEYCOMB (HIGH DENSITY CORE) F		•			•	
0.05 CLAD 2024-T3 SHEET	•					
FIBERGLASS FACED ALUMINUM HONEYCOMB (LOW DENSITY CORE) G			•			
FIBERGLASS FACED ALUMINUM HONEYCOMB (MEDIUM DENSITY CORE) H				•		
FIBERGLASS FACED ALUMINUM HONEYCOMB (MEDIUM DENSITY CORE) I				• OVER WING BOX		
FIBERGLASS FACED ALUMINUM HONEYCOMB (DUAL DENSITY CORE) J			•	•		

Main Deck Floor Panel Identification
Figure 1 (Sheet 2 of 5)

**757-200
STRUCTURAL REPAIR MANUAL**



**BASIC 4-DOOR CONFIGURATION
AIRPLANES WITH NO. 3 DOOR EMERGENCY EXITS
TYPICAL FLOOR PANEL ARRANGEMENT**

DETAIL I

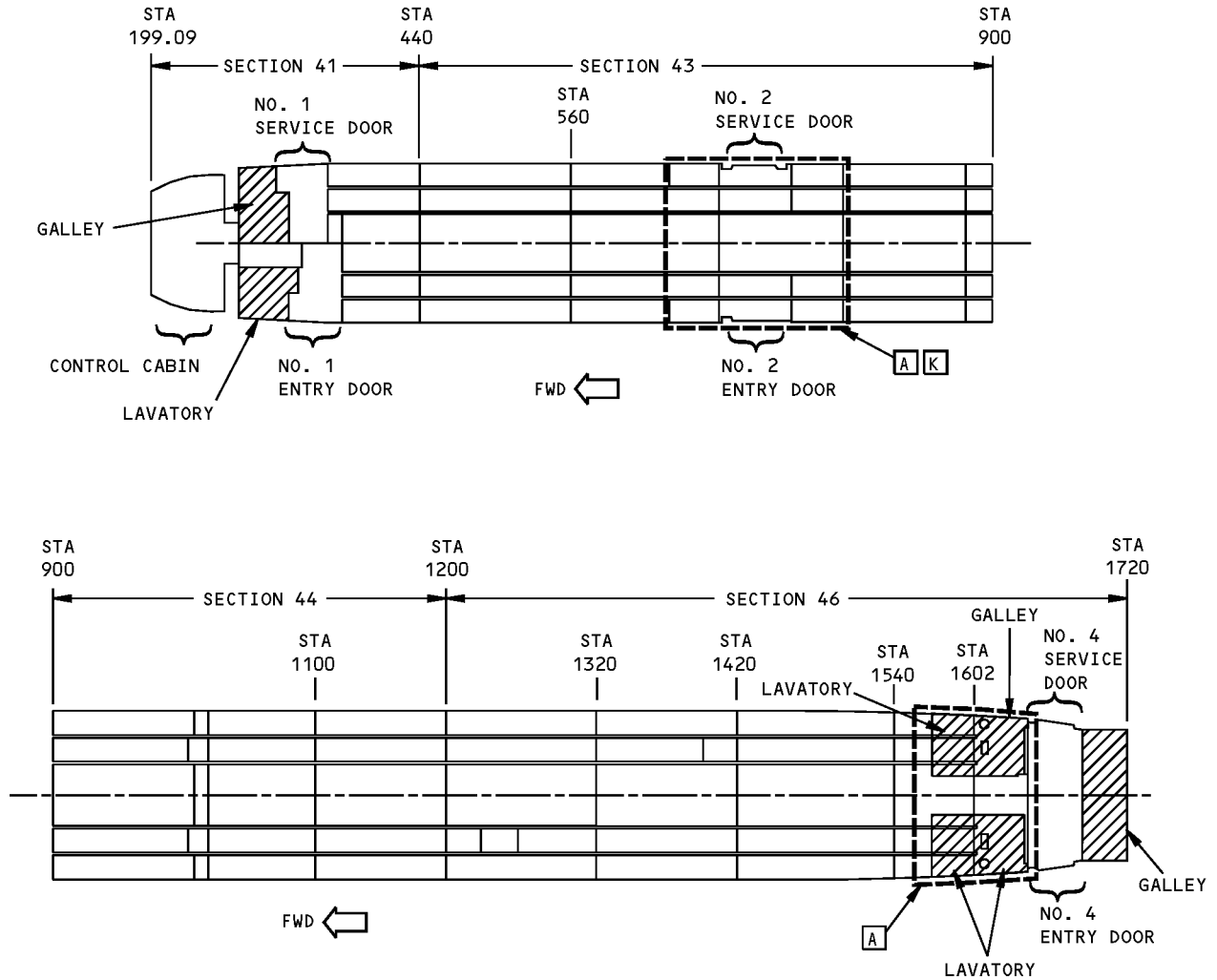
**Main Deck Floor Panel Identification
Figure 1 (Sheet 3 of 5)**

D634N201

53-00-50

IDENTIFICATION 1
Page 3
Jan 20/2005

**757-200
STRUCTURAL REPAIR MANUAL**



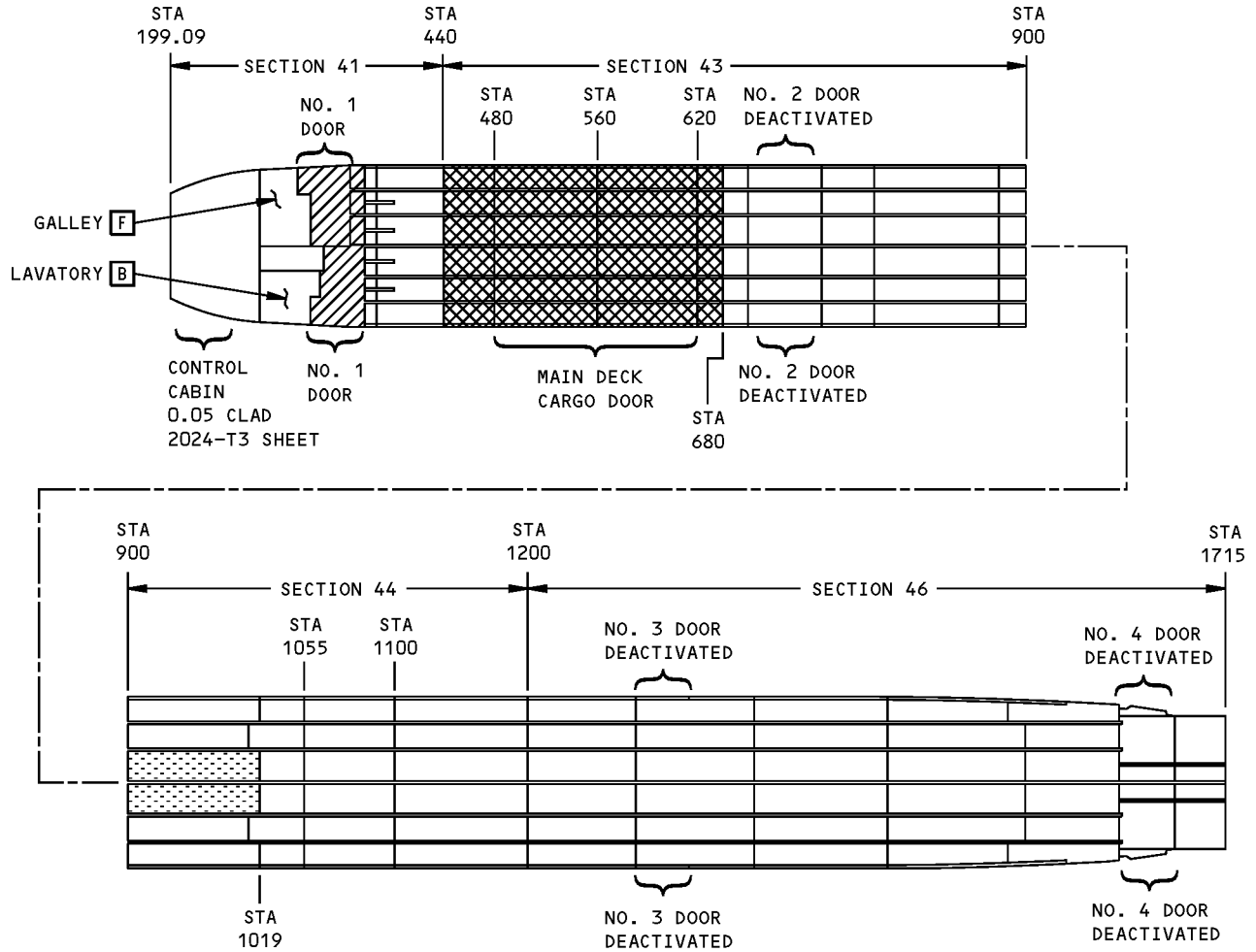
**BASIC 3-DOOR CONFIGURATION
AIRPLANES WITH OVERWING EMERGENCY EXITS
TYPICAL FLOOR PANEL ARRANGEMENT**





DETAIL II

**Main Deck Floor Panel Identification
Figure 1 (Sheet 4 of 5)**

**757-200
STRUCTURAL REPAIR MANUAL**

REFERENCE DRAWING
657N3341



-  FIBERGLASS FACED
NOMEX CORE
BMS 4-17, TYPE IX
-  FIBERGLASS FACED
NOMEX CORE
BMS 4-17, TYPE III
-  FIBERGLASS FACED
NOMEX CORE
BMS 4-17, TYPE VI
-  FIBERGLASS FACED
ALUMINUM HONEYCOMB CORE
BMS 4-23, TYPE II

FWD ←

757-SF AIRPLANES
DETAIL III

**Main Deck Floor Panel Identification
Figure 1 (Sheet 5 of 5)**

D634N201

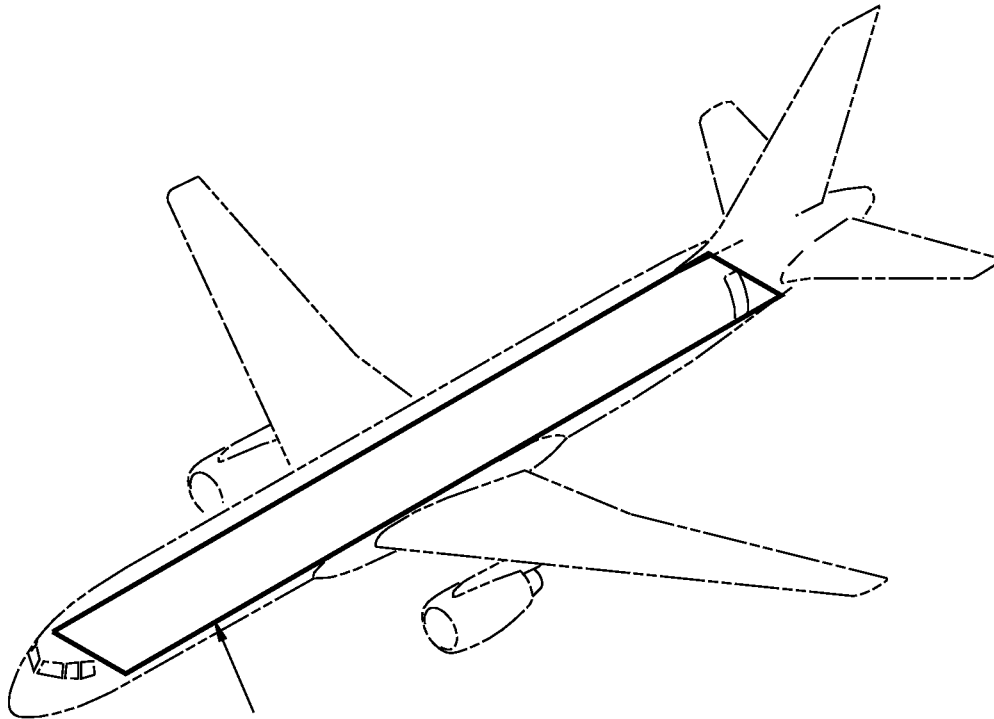
53-00-50

IDENTIFICATION 1
Page 5
Jan 20/2005



757-200
STRUCTURAL REPAIR MANUAL

ALLOWABLE DAMAGE 1 - MAIN DECK FLOOR PANELS



FOR PASSENGER AIRPLANES
SEE ALLOWABLE DAMAGE 1
(DETAIL I AND TABLE I)

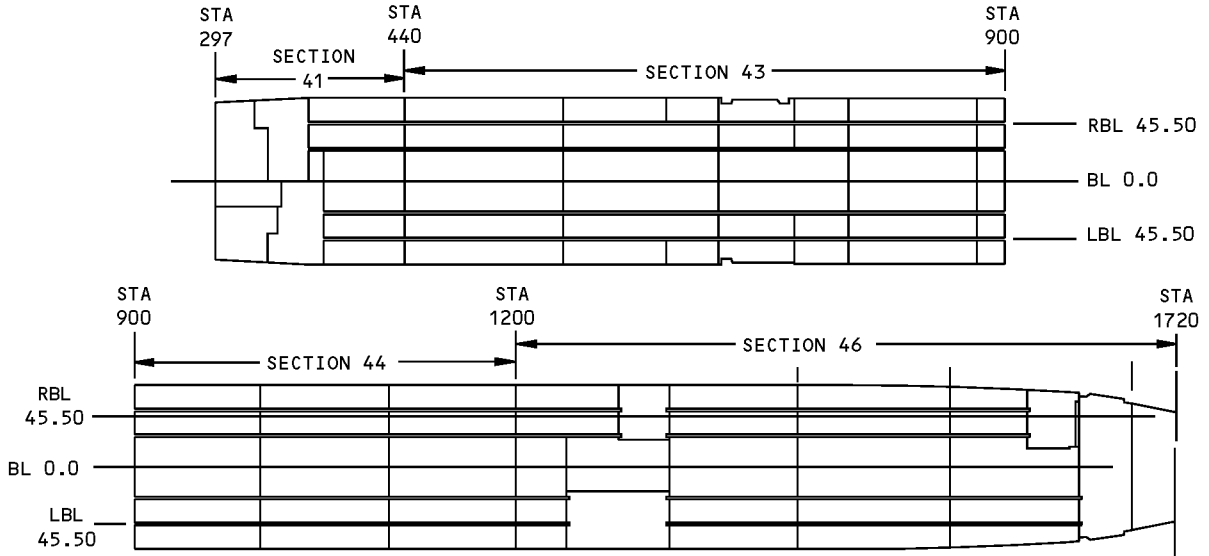
FOR 757-SF AIRPLANES ONLY
REFER TO ALLOWABLE
DAMAGE 2

Main Deck Floor Panels Allowable Damage
Figure 101 (Sheet 1 of 2)

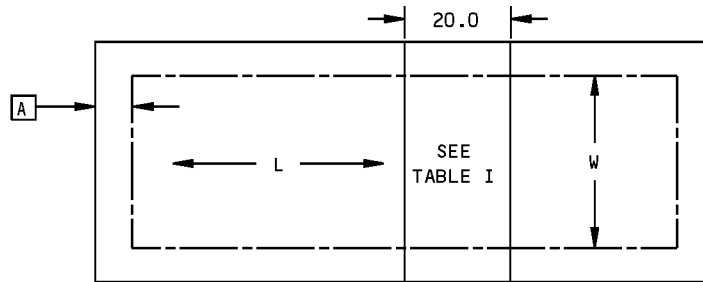
D634N201

ALLOWABLE DAMAGE 1
Page 101
53-00-50 Jan 20/2005

**757-200
STRUCTURAL REPAIR MANUAL**



**BASIC FLOOR PANEL ARRANGEMENT SHOWN
FLOOR PANEL ARRANGEMENT MAY VARY WITH OPERATOR'S OPTION
DETAIL I**



**TYPICAL FLOOR PANEL
PLAN VIEW**

ALLOWABLE DAMAGE FOR ANY 20.0 INCH LENGTH (FORE AND AFT)			
CRACKS	DENTS	HOLES	DELAMINATION
2.0 MAX LENGTH SINGLE CRACK OR MULTIPLE CRACKS TOTALING NO MORE THAN 2.0 INCHES	UP TO 4 SQUARE INCHES	UP TO 4 SQUARE INCHES	UP TO 4 SQUARE INCHES
ONLY ONE OF THE ABOVE ALLOWED PER 20.0 INCH LENGTH			

NOTES

- THIS ALLOWABLE DAMAGE DATA IS APPLICABLE TO PASSENGER AIRPLANES ONLY
- THE ALLOWABLE DAMAGE CRITERIA STATED HEREIN APPLIES TO STRUCTURAL INTEGRITY ONLY AND SHOULD NOT BE USED WHERE FLOOR PANEL FUNCTIONAL UTILITY WOULD BE IMPAIRED

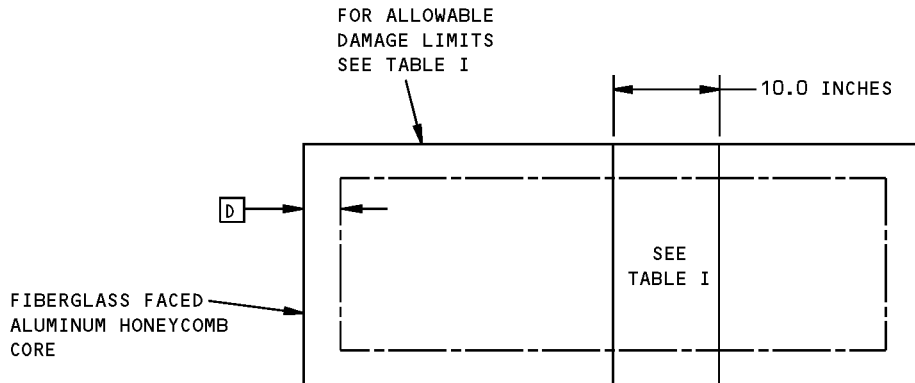
TABLE I

A NO DAMAGE ALLOWED WITHIN 3.00 INCHES OF THE EDGE OR PANEL CUTOUT

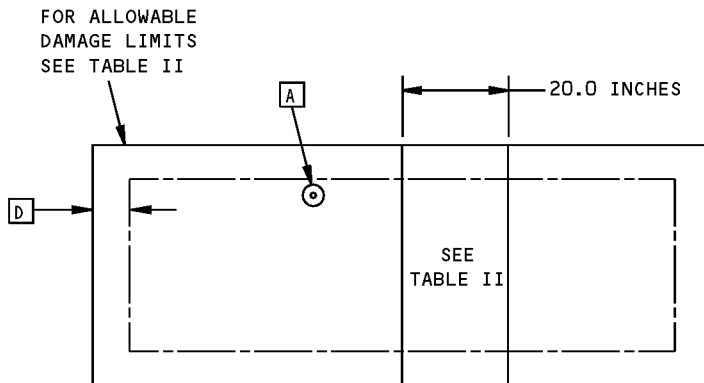
**Main Deck Floor Panels Allowable Damage
Figure 101 (Sheet 2 of 2)**

757-200
STRUCTURAL REPAIR MANUAL

ALLOWABLE DAMAGE 2 - MAIN DECK FLOOR PANELS - 757-SF



TYPICAL FLOOR PANEL FOR FIBERGLASS FACED ALUMINUM CORE PANELS
DETAIL I



TYPICAL FLOOR PANEL FOR FIBERGLASS FACED NOMEX CORE PANELS
DETAIL II

Main Deck Floor Panels Allowable Damage - 757-SF
Figure 101 (Sheet 1 of 2)



**757-200
STRUCTURAL REPAIR MANUAL**

ALLOWABLE DAMAGE FOR ANY 10.0 INCH LENGTH (FORE AND AFT) C			
CRACKS	DENTS	HOLES	DELAMINATION
B	UP TO 4 SQUARE INCHES	UP TO 4 SQUARE INCHES	UP TO 4 SQUARE INCHES
ONLY ONE OF THE ABOVE ALLOWED PER 10.0 INCH LENGTH			

FOR FIBERGLASS FACED ALUMINUM CORE PANELS
TABLE I

ALLOWABLE DAMAGE FOR ANY 20.0 INCH LENGTH (FORE AND AFT)			
CRACKS	DENTS	HOLES	DELAMINATION
B	UP TO 4 SQUARE INCHES	UP TO 4 SQUARE INCHES	UP TO 4 SQUARE INCHES
ONLY ONE OF THE ABOVE ALLOWED PER 20.0 INCH LENGTH			

FOR FIBERGLASS FACED NOMEX CORE PANELS
TABLE II

NOTES

- FOR PANEL IDENTIFICATION SEE SRM 53-00-50, IDENTIFICATION 1
- THE ALLOWABLE DAMAGE CRITERIA STATED HEREIN APPLIES TO STRUCTURAL INTEGRITY ONLY AND SHOULD NOT BE USED WHERE FLOOR PANEL FUNCTIONAL UTILITY WOULD BE IMPAIRED
- A NO DAMAGE ALLOWED WITHIN 0.50 INCH (13 mm) OF FLOOR PANEL FASTENER INSERT
- B 2.0 INCHES (50 mm) MAX LENGTH SINGLE CRACK OR MULTIPLE CRACKS TOTALING NO MORE THAN 2.0 INCHES (50 mm)
- C REMOVE MOISTURE FROM DAMAGE AREA. USE OF VACUUM AND HEAT (MAX OF 125°F (52°C)) TO REMOVE MOISTURE FROM HONEYCOMB CELLS IS RECOMMENDED. PROTECT DAMAGE FROM ENTRANCE OF WATER, SUNLIGHT OR OTHER FOREIGN MATTER BY SEALING WITH ALUMINUM FOIL TAPE (SPEED TAPE).
- D NO DAMAGE ALLOWED WITHIN 3.00 INCHES (76 mm) OF THE EDGE OR PANEL CUTOUT

**Main Deck Floor Panels Allowable Damage - 757-SF
Figure 101 (Sheet 2 of 2)**



757-200

STRUCTURAL REPAIR MANUAL

REPAIR 1 - MAIN DECK FLOOR PANEL REPAIRS

1. General

- A. These procedures are applicable to the repair of the types of floor panels which follow:
- Nomex honeycomb core with fiberglass/epoxy floor panels
 - Aluminum honeycomb core with fiberglass/epoxy floor panels
- B. Refer to Figure 201/REPAIR 1, Table I for the limits on the size of the repairs. Refer to 53-00-50, IDENTIFICATION 1 for floor panel identification.
- C. These procedures are not applicable for BMS 4-23 type II panels with overlay plies and BMS 4-17 Type IX panels.

2. References

Reference	Title
53-00-50, IDENTIFICATION 1	Main Deck Floor Panel
SOPM 20-30-99	Solvents For Final Cleaning of Composites Before Structural Bonding (Series 99)

3. Repairs

A. Dent Repair

- (1) For BMS 4-17 floor panels, cut out the damage and repair it as a hole. Dents in composite panels cause delamination and damage to the fiber.

- (2) For BMS 4-23 Type I and Type IV floor panels:

- (a) Fill dents when the largest depth of the dent is smaller than 0.030 inch. Fill dents when the largest width of the dent is 1.0 inch or less. Use BMS 5-28, Type 17, 18, 19 or 28. Cure the BMS 5-28 potting compound until it can be sanded. Sand the repair area to a smooth contour with 150 grit or smaller grit abrasive paper. Clean the repair with solvent, Series 99 (AMM/SOPM 20-30-99).

NOTE: Small dents 0.030 inch or less in depth will not decrease the strength of the floor panel if they are not repaired.

- (b) For dents that are larger than 0.030 inch (0.8 mm) in depth and 1.0 inch (25 mm) in width, or that have other damage to the skin, cut out the damage and repair it as a hole. Refer to Paragraph 3.D./REPAIR 1.

- (3) Do the steps that follow for BMS 4-23, Type II, V, and VI floor panels.

- (a) Fill dents when the largest depth of the dent is smaller than 0.060 inch (1.5 mm). Fill dents when the largest width of the dent is 1.0 inch (25 mm) or less. Use BMS 5-28, Type 17, 18, 19 or 28. Cure the BMS 5-28 potting compound until it can be sanded. Sand the repair area to a smooth contour with 150 grit or smaller grit abrasive paper. Clean the repair with solvent, Series 99, (AMM/SOPM 20-30-99).

NOTE: Small dents 0.060 inch (1.5 mm) or less in depth will not decrease the strength of the floor panel if they are not repaired.

- (b) For dents that are larger than 0.060 inch (1.5 mm) in depth and 1.0 inch in width, or that have other skin damage, cut out the damage and repair it as a hole. Refer to Paragraph 3.D./REPAIR 1.

B. Repair to one skin with undamaged core.

- (1) Insert bolts and nuts in the spacers in the vicinity of the damaged area to prevent further delamination during repair operations.

STRUCTURAL REPAIR MANUAL

- (2) Carefully cut the damaged skin with a circular hole saw and remove the damaged portion, or if the skin is cracked, drill stop holes at the extremities as shown in Figure 201/REPAIR 1, Details I and II.
 - (3) Remove spacers in damaged area.
 - (4) Mix a quantity of BMS 5-28 Type 19 potting compound as described in Paragraph 4.E./REPAIR 1. Fill all exposed core cells with potting compound to the core surface to make it flush or slightly above the outer skin surface. Cure the compound 24 hours at 75 to 85°F (24 to 29°C) or 3 hours at 120 to 130°F (49 to 54°C). Sand the potted area until it is flush with the surrounding skin.
 - (5) Apply either of the following:
 - (a) Three plies of BMS 9-3, Type H-2 or H-3 fiberglass cloth impregnated with Resin Mix 1 to a damaged top skin or bottom skin as shown in Figure 201/REPAIR 1, Detail I. Refer to Paragraph 4./REPAIR 1 for cleaning of the damaged area, and preparation and application of fiberglass repair plies.
 - (b) One ply of precured fiberglass sheet (Stratoglas 700S-EAL or Permaglass XERTT6/9) as shown in Figure 201/REPAIR 1, Detail II. Refer to Paragraph 5./REPAIR 1 for cleaning of the damaged area, and preparation and application of the fiberglass sheet.
 - (6) Reinstall spacers per Paragraph 7.A./REPAIR 1.
- C. Repair to one skin and core less than 1.0 inch (25 mm) diameter.
- (1) Insert bolts and nuts in the spacers in the vicinity of the damaged area to prevent further delamination during repair operations.
 - (2) Remove the damage by cutting a circular hole not more than 1.0 inch (25 mm) diameter, taking care not to damage the opposite skin.

NOTE: Rout out only the damaged portion of core.
 - (3) Remove spacers in damaged area.
 - (4) Fill the cavity in the core with BMS 5-28, Type 19 potting compound. Cure the compound 24 hours at 75 to 85°F (24 to 29°C) or 3 hours at 120 to 130°F (49 to 54°C). Sand the potted area until it is flush with the surrounding skin.
 - (5) Apply either of the following:
 - (a) Three plies of BMS 9-3, Type H-2 or H3 fiberglass cloth impregnated with Resin Mix 1 to a damaged top skin or bottom skin as shown in Figure 201/REPAIR 1, Detail III. Refer to Paragraph 4./REPAIR 1 for cleaning of the damaged area, and preparation and application of fiberglass repair plies.
 - (b) One ply of precured fiberglass sheet (Stratoglas 700S-EAL or Permaglass XERTT6/9) as shown in Figure 201/REPAIR 1, Detail IV. Refer to Paragraph 5./REPAIR 1 for cleaning of the damaged area, and preparation and application of the fiberglass sheet.
 - (6) Reinstall spacers per Paragraph 7.A./REPAIR 1.
- D. Repair to one skin and core greater than 1.0 inch (25 mm) diameter.
- (1) Insert bolts and nuts in the spacers in the vicinity of the damaged area to prevent further delamination during repair operations.
 - (2) Cut out the damaged area with a circular hole saw, taking care not to damage the opposite skin.
 - (3) Remove spacers.

STRUCTURAL REPAIR MANUAL

- (4) Make a core plug from similar material to the original core, 0.060 (1.5 mm) to 0.125 inch (3 mm) smaller than the diameter of the hole, as shown in Figure 201/REPAIR 1 Detail III or IV. Cut core plug from a sheet thick enough so that the upper and/or lower surface of the plug protrudes slightly above the upper and/or lower surface of the floor panel.
 - (5) Pot the core plug into the hole with BMS 5-28, Type 19 potting compound. Cure the compound 24 hours at 75 to 85°F (24 to 29°C) or 3 hours at 120 to 130°F (49 to 54°C). Sand the plug until it is flush with the surrounding skin.
 - (6) Apply either of the following:
 - (a) Three plies of BMS 9-3, Type H-2 or H-3 fiberglass cloth impregnated with Resin Mix 1 to a damaged top skin or bottom skin as shown in Figure 201/REPAIR 1, Detail III. Refer to Paragraph 4./REPAIR 1 for cleaning of the damaged area, and preparation and application of fiberglass repair plies.
 - (b) One ply of precured fiberglass sheet (Stratoglas 700S-EAL or Permaglass XERTT6/9) as shown in Figure 201/REPAIR 1, Detail IV. Refer to Paragraph 5./REPAIR 1 for cleaning of the damaged area, and preparation and application of the fiberglass sheet.
 - (7) Reinstall spacers Paragraph 7.A./REPAIR 1.
- E. Repair to both skins and core.
- (1) Insert bolts and nuts in the spacers in the vicinity of the damaged area to prevent further delamination during repair operations.
 - (2) Where both skins and core are damaged, cut right through the panel with a circular hole saw.
 - (3) Repair the panel as described in Paragraph 3.C./REPAIR 1, except that the fiberglass repair plies must be installed on both upper and lower skins.
 - (4) Reinstall spacers per Paragraph 7.A./REPAIR 1
- F. Repairs to delaminated areas under 16 square inches (103 square cm) in area.

NOTE: It is preferable to repair delamination between skin plies by removal of the skin from the affected area as described in par 3.B. Repair by adhesive injection as described in this paragraph is an alternative.

Delamination over 16 square inches (103 square cm) in area between skin plies must be repaired per Paragraph 3.B./REPAIR 1.

Delamination between skin and honeycomb core must be repaired per Paragraph 3.B./REPAIR 1.

- (1) Install bolts and nuts in the spacers to ensure that the skins will not be separated from the spacers during the course of repair work.
 - (2) Locate the void by nondestructive inspection (NDI) or coin tap.
 - (3) Drill a 0.125-inch diameter hole at each end of the void. Only one hole is required if the void extends to the edge of a panel.
 - (4) Prepare Resin Mix 1 as described in par. 6, and inject it into one hole until it comes out of the other hole or the panel edge.
 - (5) Fill the 0.125-inch diameter holes with Resin Mix 1 and finish off flush with the surrounding surface.
 - (6) Apply vacuum bag or 10 to 15-psi pressure and cure resin 10 to 12 hours at 70°F (21°C) or 30 to 60 minutes at 200°F (93°C).
- G. Repair to edge delamination between skin plies.

STRUCTURAL REPAIR MANUAL

- (1) Install bolts and nuts in the spacers to ensure that the skins will not be separated from the spacers during the course of repair work.
- (2) Insert a dull, clean spatula between the delaminated skin plies to determine the extent of the delamination.

NOTE: If delamination is greater than 4 square inches, repair per Paragraph 3.B./REPAIR 1

- (3) Prepare Resin Mix 1 as described in Paragraph 6./REPAIR 1 and inject it into the damaged area with a syringe or sealant gun and clamp the edge firmly into shape.
- (4) If the edge potting or core is damaged, fill with BMS 5-28, Type 19 potting compound mixed as described in Paragraph 4.E./REPAIR 1 (Figure 201/REPAIR 1, Detail V or VI). Cure the compound 24 hours at 75 to 85°F (24 to 29°C) or 3 hours at 120 to 130°F (49 to 54°C).

H. Repair to edge delamination between skin and honeycomb core.

- (1) Repair edge delamination between skin and honeycomb core per Paragraph 3.B./REPAIR 1

I. Repair to edge delamination and damage to core for nomex core panels.

- (1) Insert bolts and nuts in the spacers in the vicinity of the damaged area to prevent further delamination during repair operations.
- (2) Carefully trim off delaminated skin and remove damaged portion of core. Remove spacers and plugs in damaged area.
- (3) Fill cavity in core with BMS 5-28, Type 19 potting compound. Cure the compound 24 hours at 75 to 85°F (24 to 29°C) or 3 hours at 120 to 130°F (49 to 54°C). Sand the potted area flush with surrounding skin and panel edge.

NOTE: If damage to core is greater than 4 square inches, bond a section of core with one skin attached, or an undamaged section of a scrap panel with one skin removed, into the trimmed area with BMS 5-28, Type 19 potting compound as shown in Figure 201/REPAIR 1, Detail VII or VIII. The attached skin should correspond to the removed skin of the panel being repaired. The maximum gap between the new and trimmed face sheet must be 0.06 inch (1.5 mm).

- (4) Apply either of the following:
 - (a) Three plies of BMS 9-3, Type H-2 or H-3 with fiberglass cloth impregnated with Resin Mix 1 to a damaged top skin or bottom skin as shown in Figure 201/REPAIR 1, Detail III. Refer to Paragraph 4./REPAIR 1 for cleaning of the damaged area, and preparation and application of fiberglass repair plies.
 - (b) One ply of precured fiberglass sheet (Stratoglas 700S-EAL or Permaglass XERTT6/9) as shown in Figure 201/REPAIR 1, Detail IV. Refer to Paragraph 5./REPAIR 1 for cleaning of the damaged area, and preparation and application of the fiberglass sheet.
- (5) Reinstall spacers per Paragraph 7./REPAIR 1.

J. Time Limited - This repair is permitted only for floor panels installed between LBL 45.5 and RBL 45.5. The skin on the opposite side of the panel where damage has occurred must have no damage. Refer to Figure 202/REPAIR 1.

- (1) Remove the fasteners that attach the floor panel to the structure below it.
- (2) Make the shear plate of 0.063 inch thick 7075-T6 Bare or Clad sheet. Put it on the top of the floor panel. The shear plate must:
 - Extend to the lateral edges of the panel



757-200

STRUCTURAL REPAIR MANUAL

- Extend to the next forward or aft location of a floor beam which has no damage. Locations to attach it to the floor beam must be available.
- (3) Bond the shear plate to the floor panel with BMS 5-92, Type I adhesive.
- (4) Drill the fastener holes through the shear plate at the initial floor panel attach fastener locations. Drill the repair fastener holes. Keep the fastener pitch and the fastener spacing to a maximum of 6.5 inches. Adjust the pitch and the spacing as necessary so that you do not drill repair fastener holes in the floor structure below the floor panel.
- (5) Install BACB30NW6K hex drive bolts with BACC30AB3C collars. Install longer fasteners as necessary at the initial floor panel attachment locations. Install a BACB30MS6K bolt with a BACN10GW nut and a BACW10BN()SP washer:
 - In areas where the floor panel goes below adjacent structure
 - In areas where you cannot get access to the fasteners that attach the floor panel to the structure below.
- (6) For a time-limited repair, you must do one of these two procedures at the next "C" check or before:
 - Replace the floor panel
 - Make a permanent repair.

4. Application of Fiberglass Repair Plies

- A. Lightly sand the area to be covered by the fiberglass repair plies, and for 0.50 inch all around the area.
- B. Clean the area with oil-free air.
- C. Wipe the surfaces with a clean cloth moistened with solvent, Series 99 (AMM/SOPM 20-30-99).
- D. Cut a piece of BMS 9-3, Type H-2 or H-3 fiberglass cloth of sufficient size to make the required number of repair plies.
- E. Cut two pieces of parting film approximately 3 inches larger than the fiberglass cloth.
- F. Spread Resin Mix 1 over one piece of parting film and place the fiberglass cloth on top of the resin. The weight of resin required is approximately equal to the weight of the cloth.
- G. Lay the second piece of parting film on top of the fiberglass cloth and press the resin through the cloth with a squeegee or roller.
- H. Cut the repair plies to the desired size.
- I. Remove the parting film from one side of one of the repair plies. Apply the exposed side of the repair ply to the damaged panel and lightly squeegee over the remaining parting film to remove wrinkles and entrapped air. Take care not to apply excessive pressure on the squeegee or too much resin will be squeezed from the repair ply. After installation remove the top parting film.
- J. Apply the remaining repair plies, one at a time, in the same manner as the first ply.
- K. Seal a diaphragm of PVA film over the repair area using extruded sealing tape, incorporating a vacuum sniffer tube.
- L. Attach a vacuum hose to the sniffer to evacuate the space under the film, sweep the area with a squeegee to remove any air bubbles evident and maintain a minimum vacuum of 20 inches of mercury for the duration of the cure.
- M. Cure the resin for approximately 10 to 12 hours at 70°F (21°C) or 30 to 60 minutes at 200°F (93°C).
- N. After the resin has cured remove the PVA film and lightly sand the area with 180 grit sandpaper, or equivalent.

STRUCTURAL REPAIR MANUAL

- O. Apply a coat of Sealer Resin over the repair area.
- P. Allow the Sealer Resin to cure for a minimum of 24 hours at 70°F (21°C) before using the panel.

5. Application of Precured Fiberglass Sheet

- A. Remove the existing primer or paint finish over the area to which the fiberglass patch is to be applied, using a Tycro Type 30A very fine aluminum oxide unitized wheel attached to a drill motor or by hand sanding with a 200-grit or finer sandpaper.
- B. Mask any exposed core with Teflon or lead tape.
- C. Clean the abraded area with solvent, Series 99 (AMM/SOPM 20-30-99).
- D. If the surface was unpainted remove surface gloss by sanding with fresh pieces of Scotchbrite Type A, taking care not to penetrate the glass fabric. Reclean the abraded area with solvent, Series 99 (AMM/SOPM 20-30-99), or use oil-free compressed air to remove the sanding dust.
- E. Remove any masking tape applied to exposed core.
- F. Cut the repair patch from Stratoglas 700S-EAL or Permaglass XERTT6/9 fiberglass sheet of the same thickness as the skin being repaired.

Prepare the faying surface as described in Paragraph 5.D./REPAIR 1

- G. Apply a uniform coat of EC2216 adhesive (BMS 5-92, Type 1), prepared as described in par. 5, to both the floor panel and the fiberglass patch.
The adhesive should be from 0.005 to 0.010 inch thick on each surface.
- H. Apply the patch and clamp or bag the surfaces together and hold under a minimum vacuum of 20 inches of mercury or 10 to 15 pounds (4.5 to 6.8 kg) per square inch clamping pressure.
- I. Cure the bond for 16 hours at room temperature or for 3 hours at 140 (60°C) to 160°F (71°C) before removing the clamping pressure.
- J. Leave the fillet formed by the adhesive squeeze out at the edges of the patch to seal the joint.
- K. Restore the finish.

6. Preparation of Resin Mixes

WARNING: THESE CHEMICALS CONTAIN TOXIC INGREDIENTS. PROVIDE ADEQUATE VENTILATION AND PROTECT THE SKIN AND EYES FROM CONTACT WITH UNCURED RESIN OR CURING AGENT. WEAR RUBBER GLOVES OVER COTTON GLOVES FOR PROTECTION OF HANDS. IF SKIN IS EXPOSED TO DIRECT CONTACT WITH UNCURED RESINS OR CURING AGENT WASH WITH SOAP AND WARM WATER. AVOID THE USE OF SOLVENTS FOR CLEANING THE SKIN.

- A. Resin Mix 1
 - (1) Add 15 parts by weight of Epocast 9816 hardener to 100 parts by weight of Epocast 50A resin and mix thoroughly.
 - (2) Pot life of the mixture is approximately 45 to 60 minutes at 75°F (24°C).
- B. Alternative Resin Mix 1
 - (1) Add 15 parts by weight of Epocast 8442B hardener to 100 parts by weight of Epocast 8442 Mod III resin and mix thoroughly.
 - (2) Pot life of the mixture is approximately 45 to 60 minutes at 75°F (24°C).
- C. Sealer Resin
 - (1) Add 10 parts by weight of Epocast 941 hardener to 100 parts by weight of Epocast 156 resin and mix thoroughly.

**757-200
STRUCTURAL REPAIR MANUAL**

(2) Pot life of the mixture is approximately 45 to 60 minutes at 70°F (21°C).

D. EC2216 Adhesive (BMS 5-92, Type 1)

(1) The adhesive must be mixed thoroughly to a uniform gray color in the following proportions. Scrape the sides and bottom of the container frequently to pull uncombined material into the mix.

Table 201:

Component	Weight	Volume
Base B (Off-White)	100	140
Hardener A (Gray)	138	146

(2) Pot life of batches less than 6 ounces by weight is 2 hours at 75°F (24°C). Larger batches or higher temperatures will reduce the pot life appreciably.

E. BMS 5-28 Type 19 Potting Compound

(1) Weigh the components to within ± 27 percent of the proportions specified on the package. Do not mix a larger batch than 350 grains (23 grams).

(2) Mix the components together, using long strokes to avoid the inclusion of air, until the mixture obtains an even color. Do not thin resins.

(3) Pot life of the mixture is approximately 20 minutes at 75°F (24°C).

7. Reinstallation of Floor Panel Spacers (See Fig. 201, Details IX and X)

A. Spacers that have been removed from damaged area are to be reinstalled as follows:

(1) Determine location of original spacers.

(2) Drill a 0.44 to 0.47 inch diameter hole for installation of the SL-5107-A3 series insert. Cut through the floor panel by any procedure which avoids damage extending more than 0.050 inch (12.7 mm) from the hole edge on either side of the panel. Avoid dimpling of skin and delamination between skin and core.

NOTE: Centerline of hole must be maintained. Hole must be clean and free of loose core pieces which can interfere with closing or bonding of inserts. Loose fibers shall be limited to areas which will be covered by the head of the installed insert.

No liquid coolants or lubricants are permitted.

(3) Solvent clean the surface with a clean, lint-free cloth wetted with (but not saturated) genklene or chlorothene. Do not allow the solvent to evaporate from the surface.

(4) Wipe the surface dry with a clean dry cloth. Do not touch or contaminate cleaned surfaces.

(5) Degrease inserts using appropriate safety precautions.

(6) Mix the BMS 5-107 adhesive according to the supplier's recommended ratio (on the container) within ± 5 percent.

NOTE: The adhesive shall be used within 45 minutes at temperatures not to exceed 90°F (32°C). All insert installations must be completed and cure started within 90 minutes of mixing.

(7) Apply the adhesive in any manner that will assure the adhesive covers the faying surface between the insert flange and panel after insert installation.

(8) Assemble the inserts to the panel so that the flange is on the lower side of the panel.



757-200

STRUCTURAL REPAIR MANUAL

- (9) Upset the upper side of the insert using a (ST3109H) flare fitting on a rivet squeezer for the SL-5107-A3 series insert (Figure 201/REPAIR 1, Detail IX). Adjust upset pressure to provide dimension between the panel face sheet and the insert as shown in Figure 201/REPAIR 1, Detail X after insert is upset.

NOTE: Boelube or liquid cetyl alcohol may be used on the forming tool to aid the forming action and increase tool life.

- (10) All adhesives shall be removed from the inside bore of the insert prior to cure. Visually check for evidence of adhesive at the faying surface edge between the insert flange and the panel.

NOTE: Squeezed out fillets of adhesive are acceptable and need not be wiped off unless the adhesive extends more than .015 (2 mm) above the surface of the insert.

- (11) Cure the adhesive at 150 to 170°F (66 to 77°C) for 2 hours followed by a post cure of 24 hours at 68°F (20°C) minimum.

NOTE: Panels may be installed after initial 2-hours, 160°F (71°C) cure.

8. Materials

- A. Refer to the Boeing Material Specification (BMS) Qualified Products List (QPL) for the sources of repair materials.

STRUCTURAL REPAIR MANUAL

REPAIR LIMITS FOR DAMAGE TO PANELS H		
TYPE OF DAMAGE	LENGTH OR DIAMETER OF DAMAGE (INCHES)	DEPTH OF DAMAGE (INCHES)
PLY DELAMINATION	D F	
CRACK OR HOLE	D	THROUGH FACE PLY
GOUGE	D	THROUGH FACE PLY INTO CORE
HOLE	D	COMPLETELY THROUGH PANEL
SCRATCH	D	A
DENT	D	G

TABLE I

NOTES

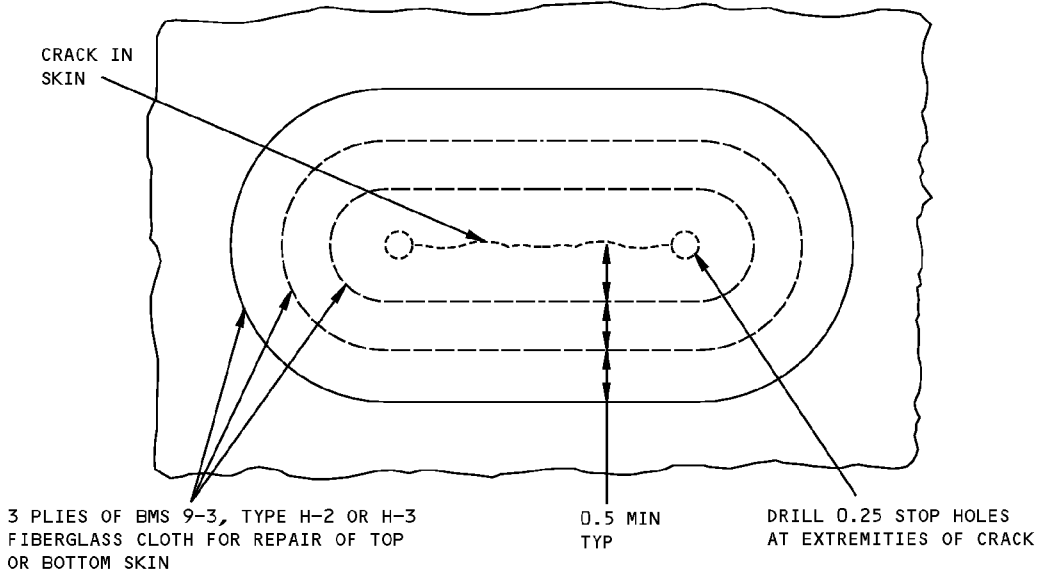
- A** SAND OUT SCRATCHES UP TO 0.015 INCH (0.38 mm) DEEP ON BOTTOM FACE WITH 180 GRIT OR FINER SANDPAPER. APPLY RESIN MIX 1 TO THE AFFECTED AREA AFTER REWORK. DEEPER SCRATCHES MUST BE REPAIRED IN A SIMILAR MANNER TO A CRACK
- B** SAME MATERIAL AND TYPE AS DAMAGED CORE (NONMETALLIC HONEYCOMB CORE PER BMS 8-124 OR ALUMINUM HONEYCOMB CORE PER BMS 4-4, SAME CLASS, TYPE, AND GRADE AS CORE BEING REPLACED)
- C** CORE AND SKIN SAME AS ORIGINAL MAY BE MADE FROM SCRAP PANEL WITH ONE SKIN REMOVED
- D** THERE ARE NO STRUCTURAL LIMITATIONS ON THE SIZE OF REPAIRABLE DAMAGE. THE SIZE OF REPAIRABLE DAMAGE IS TO BE DETERMINED BY THE PRACTICABILITY OF MAKING A SATISFACTORY REPAIR WITH THE FACILITIES AVAILABLE
- E** BOEING TOOL NO. ST3109H OR SHUR-LOK TOOL NO. SLT5107-3P. OBTAIN FROM:
 SHUR-LOK CORPORATION
 2541 WHITE RD
 IRVINE, CA 92713
 OR
 SHUR-LOK INTERNATIONAL
 RUE du MIDI, 7-9
 4822 PETIT-RECHAIN
 BELGIQUE

- F** THE TIME LIMITED REPAIR CAN BE USED FOR DELAMINATIONS UP TO 12 INCHES (300 mm) IN DIAMETER. THIS IS APPLICABLE TO ANY 20.0 INCH (500 mm) LENGTH (FORWARD AND AFT) BETWEEN LBL 45.5 AND RBL 45.5.
- G** REFER TO PAR. 3 FOR DENT REPAIR LIMITS.
- H** THIS REPAIR IS NOT APPLICABLE FOR BMS 4-17 TYPE IX PANELS AND BMS 4-23 TYPE II PANELS WITH OVERLAY PLIES.

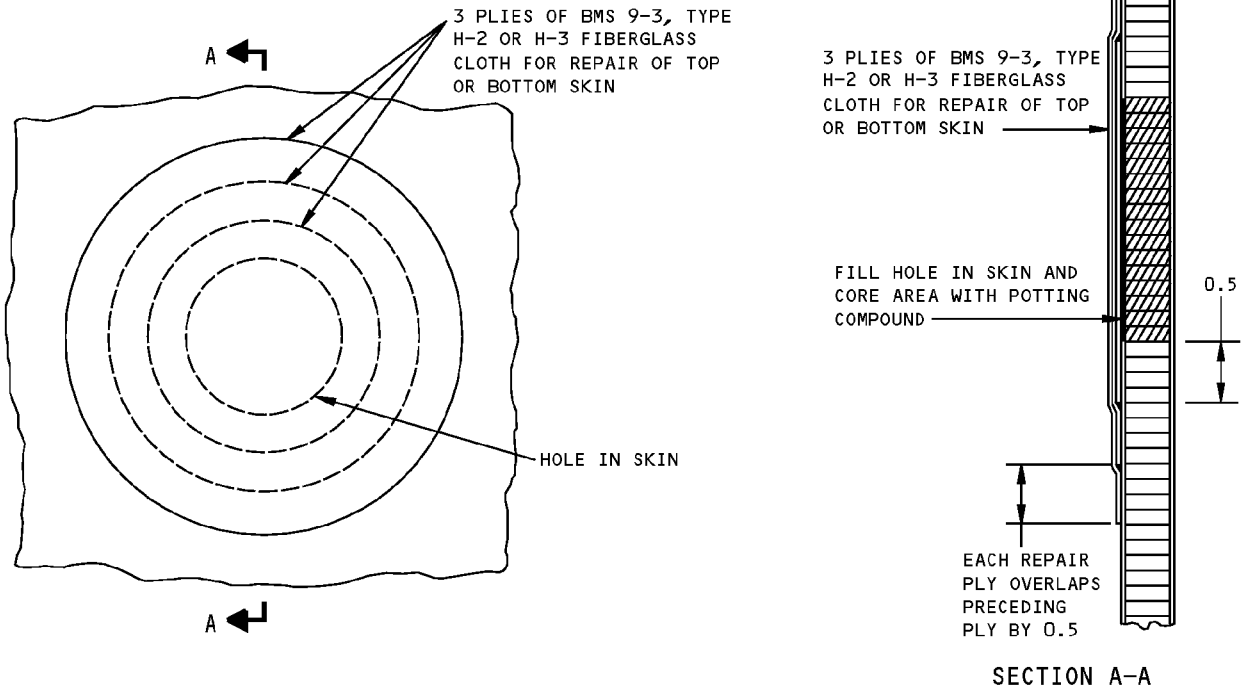
REPAIR MATERIAL			
	PART	QTY	MATERIAL
1	CORE	AS REQ	B
2	FILLER	AS REQ	C

**Fiberglass Faced Floor Panel Repair
Figure 201 (Sheet 1 of 9)**

**757-200
STRUCTURAL REPAIR MANUAL**



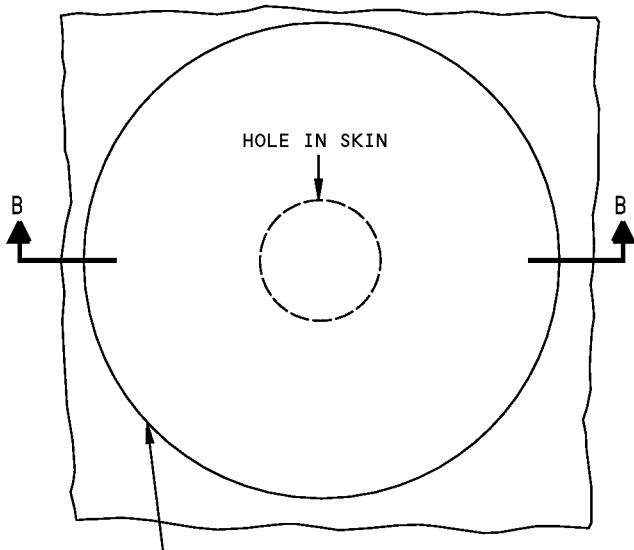
TYPICAL REPAIR TO CRACK IN SKIN USING FIBERGLASS CLOTH REPAIR PLYS



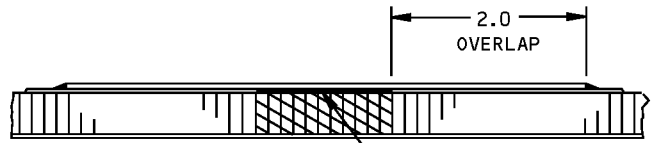
TYPICAL REPAIR TO HOLE OR CRACK IN SKIN USING FIBERGLASS CLOTH REPAIR PLYS
DETAIL I

**Fiberglass Faced Floor Panel Repair
Figure 201 (Sheet 2 of 9)**

**757-200
STRUCTURAL REPAIR MANUAL**



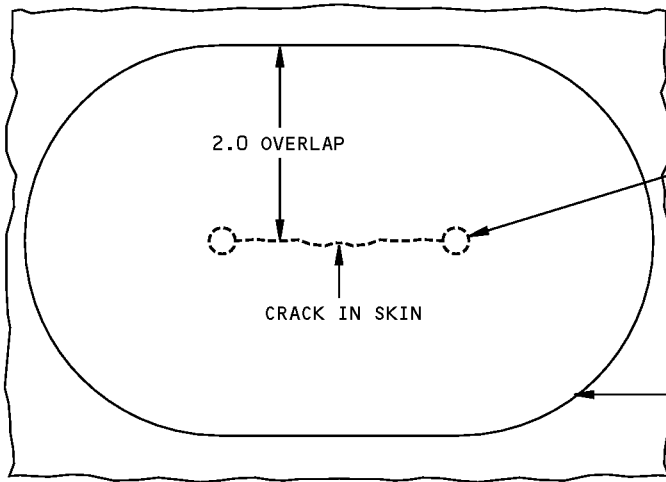
STRATOGLAS 700S-EAL
OR
PERMAGLASS XERTT6/9
PRECURED FIBERGLASS SHEET



FILL HOLE IN SKIN AND
CORE AREA WITH POTTING
COMPOUND

SECTION B-B

REPAIR FOR HOLE



DRILL 0.25 DIA STOP
HOLES AT EXTREMITIES
OF CRACK

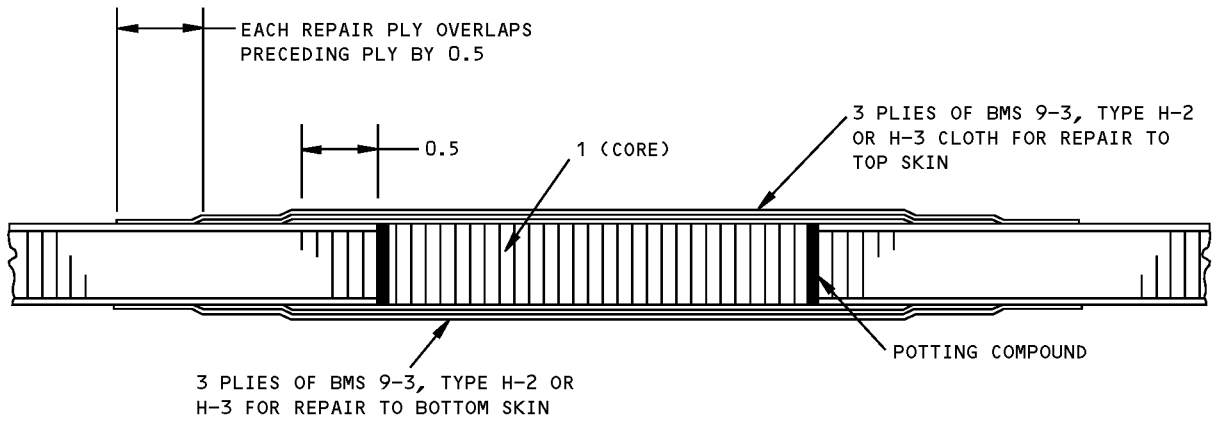
STRATOGLAS 700S-EAL
OR
PERMAGLASS XERTT6/9
PRECURED FIBERGLASS SHEET

REPAIR FOR CRACK

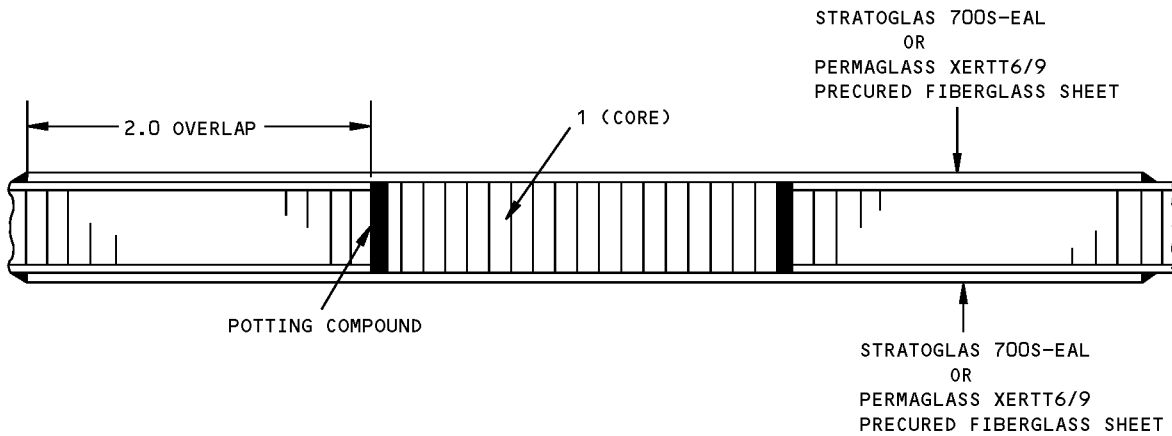
TYPICAL REPAIR TO HOLE OR CRACK IN SKIN USING PRECURED FIBERGLASS SHEET
DETAIL II

**Fiberglass Faced Floor Panel Repair
Figure 201 (Sheet 3 of 9)**

**757-200
STRUCTURAL REPAIR MANUAL**



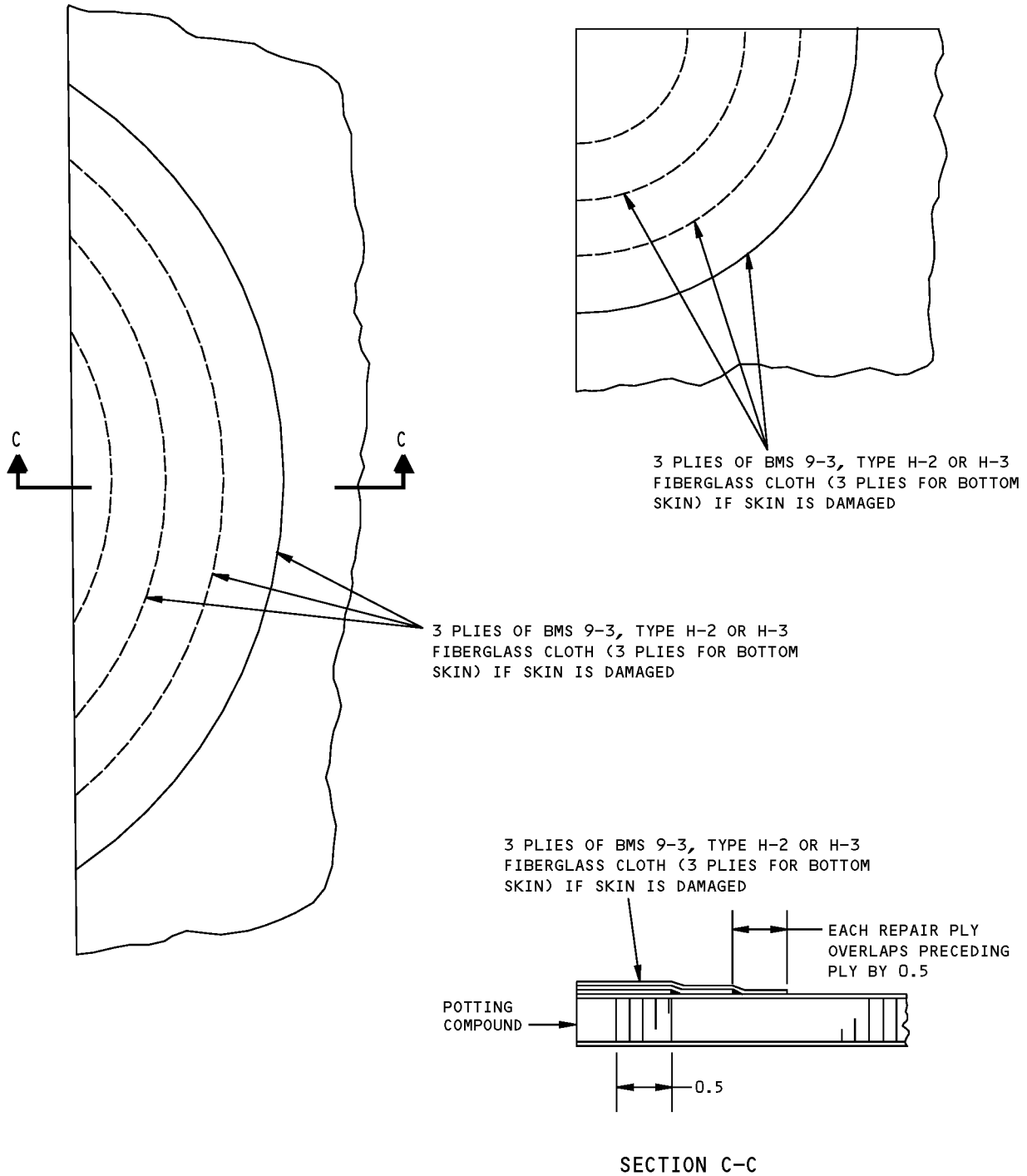
TYPICAL REPAIR TO SKIN AND CORE USING FIBERGLASS CLOTH REPAIR PLYS
DETAIL III



TYPICAL REPAIR TO SKIN AND CORE USING PRECURED FIBERGLASS SHEET
DETAIL IV

**Fiberglass Faced Floor Panel Repair
Figure 201 (Sheet 4 of 9)**

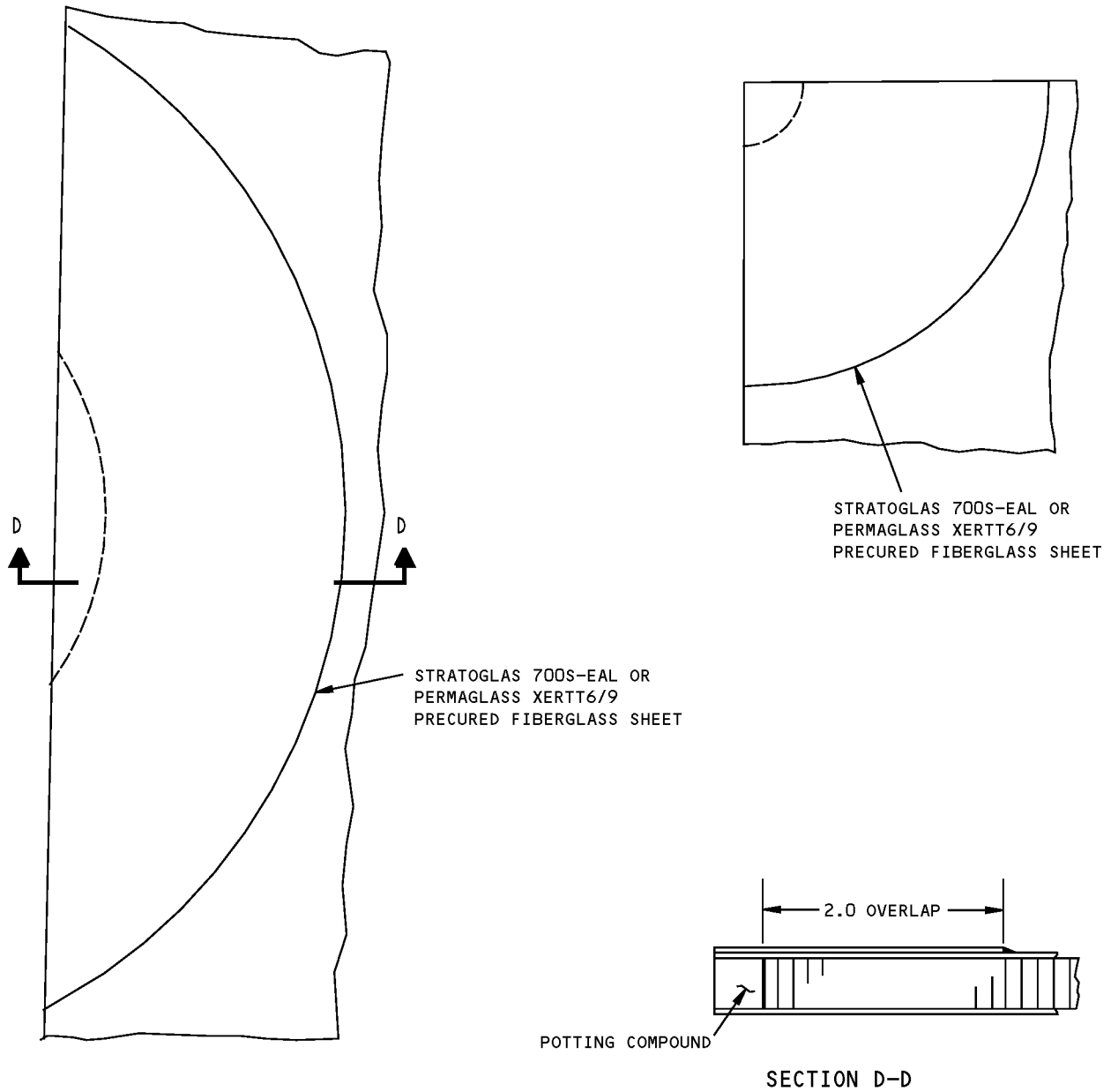
**757-200
STRUCTURAL REPAIR MANUAL**



TYPICAL REPAIR TO CORE AT EDGE OF PANEL USING FIBERGLASS CLOTH REPAIR PLYS
DETAIL V

**Fiberglass Faced Floor Panel Repair
Figure 201 (Sheet 5 of 9)**

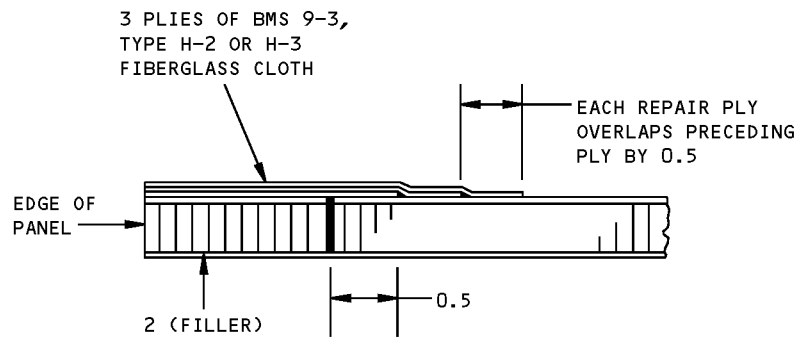
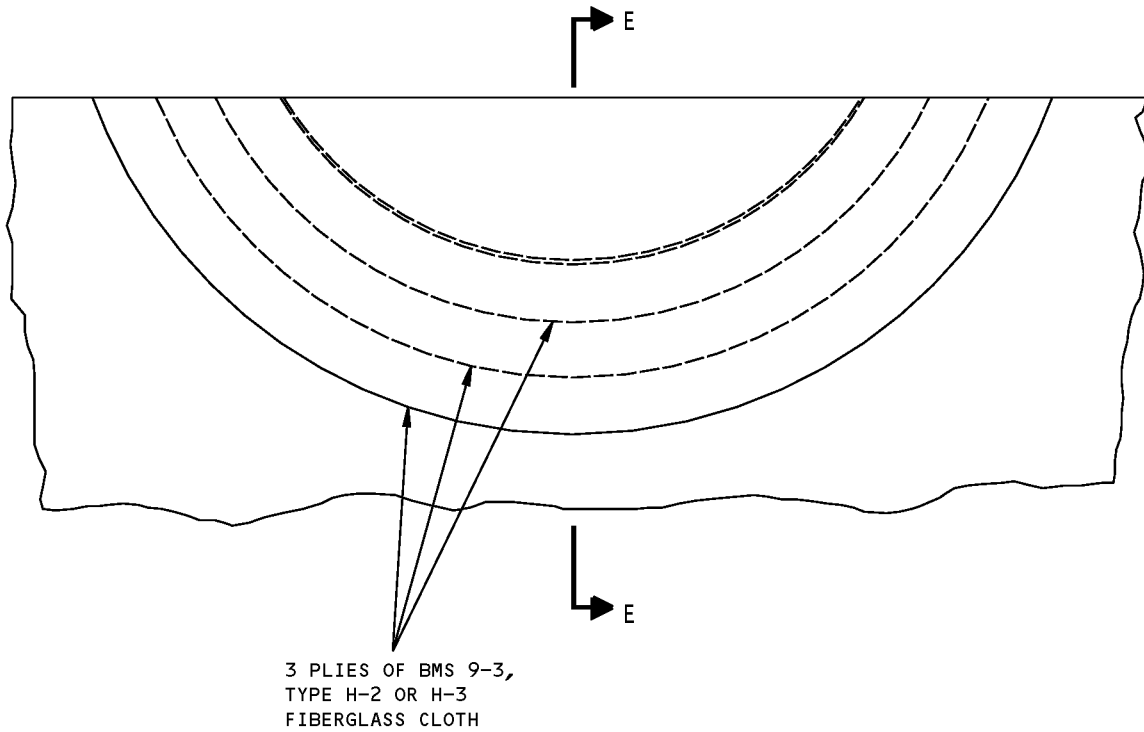
**757-200
STRUCTURAL REPAIR MANUAL**



TYPICAL REPAIR TO CORE AT EDGE OF PANEL USING PRECURED FIBERGLASS SHEET
DETAIL VI

**Fiberglass Faced Floor Panel Repair
Figure 201 (Sheet 6 of 9)**

**757-200
STRUCTURAL REPAIR MANUAL**

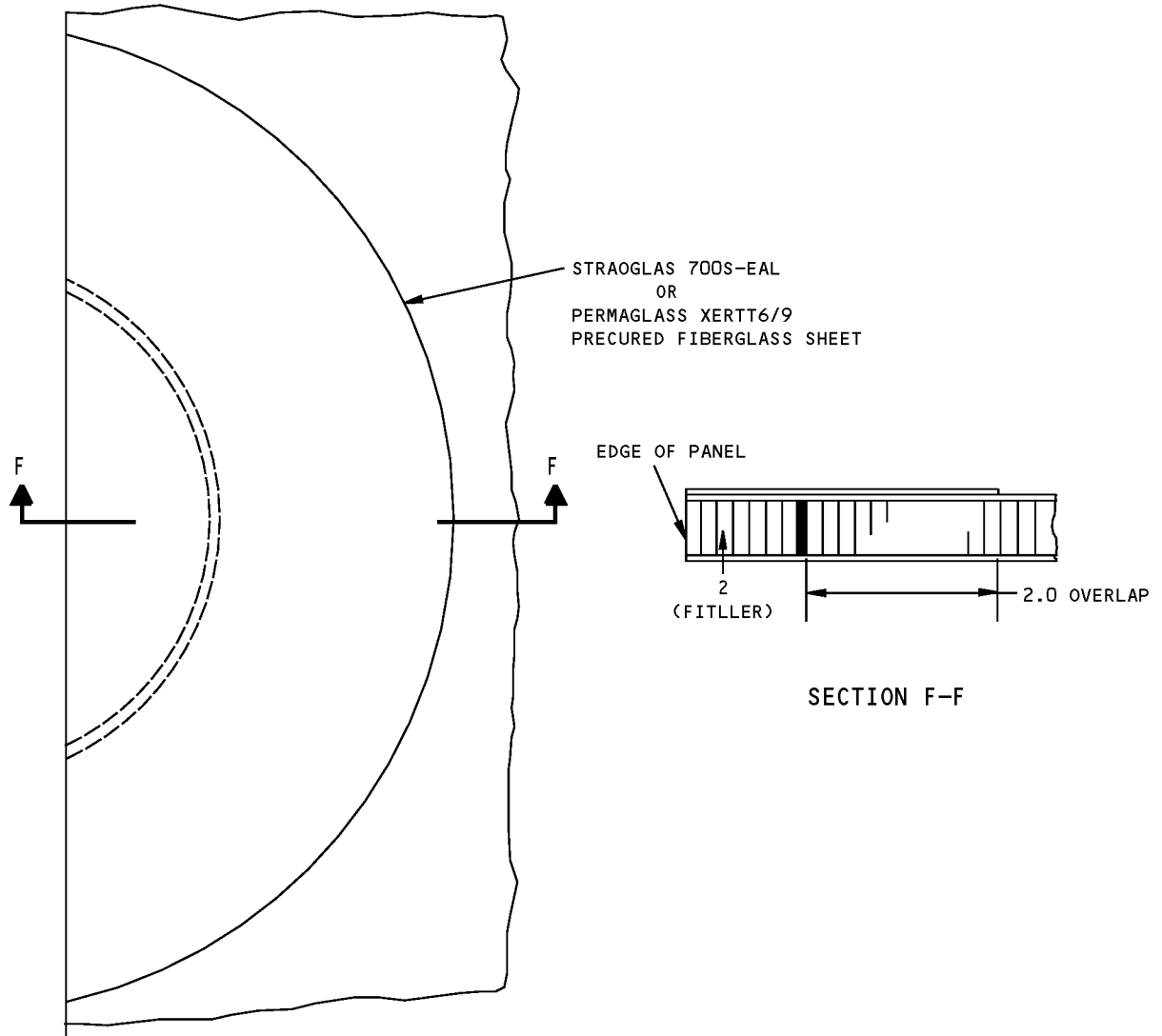


SECTION E-E

TYPICAL REPAIR TO SKIN AND CORE AT EDGE OF PANEL USING FIBERGLASS CLOTH REPAIR PLYS
DETAIL VII

**Fiberglass Faced Floor Panel Repair
Figure 201 (Sheet 7 of 9)**

**757-200
STRUCTURAL REPAIR MANUAL**

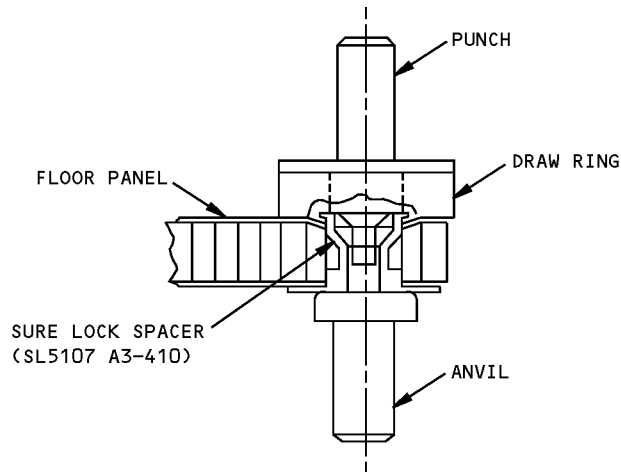


TYPICAL REPAIR TO SKIN AND CORE AT EDGE OF PANEL
USING PRECURED FIBERGLASS SHEET

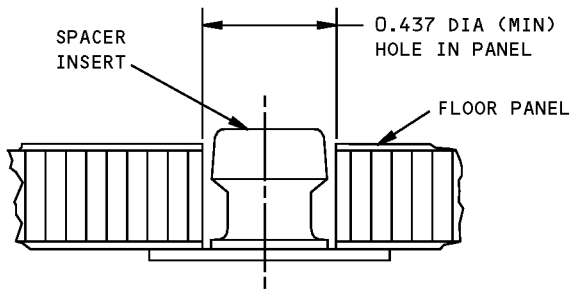
DETAIL VIII

**Fiberglass Faced Floor Panel Repair
Figure 201 (Sheet 8 of 9)**

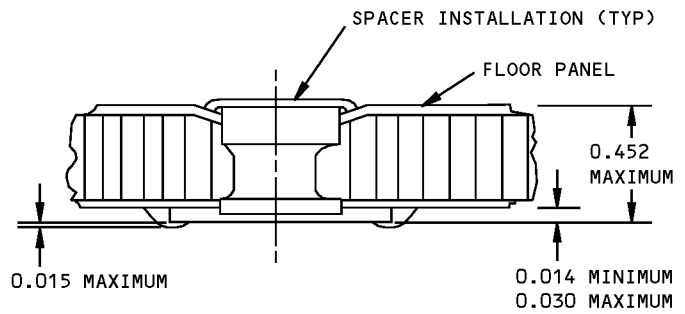
**757-200
STRUCTURAL REPAIR MANUAL**



INSTALLATION TOOL [E] FOR SURE LOCK SPACER SL5107 A3-410
DETAIL IX



BEFORE SWAGING

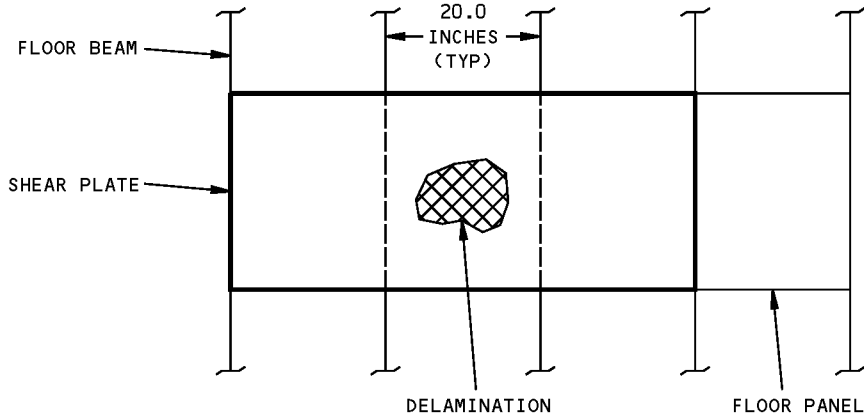


AFTER SWAGING

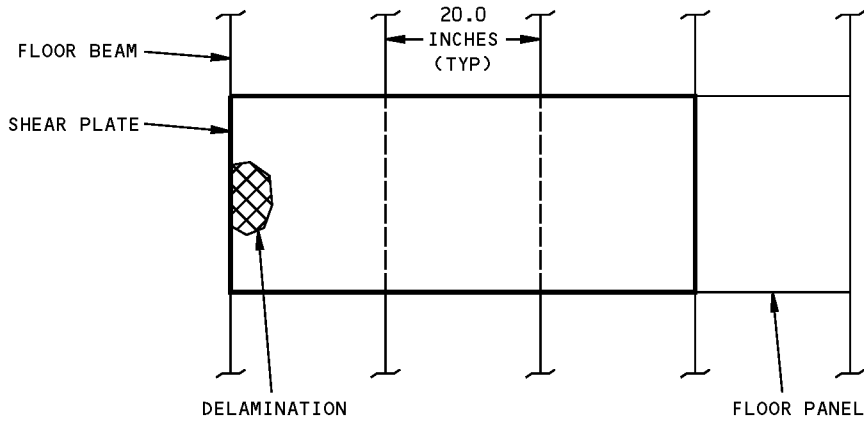
DETAIL X

**Fiberglass Faced Floor Panel Repair
Figure 201 (Sheet 9 of 9)**

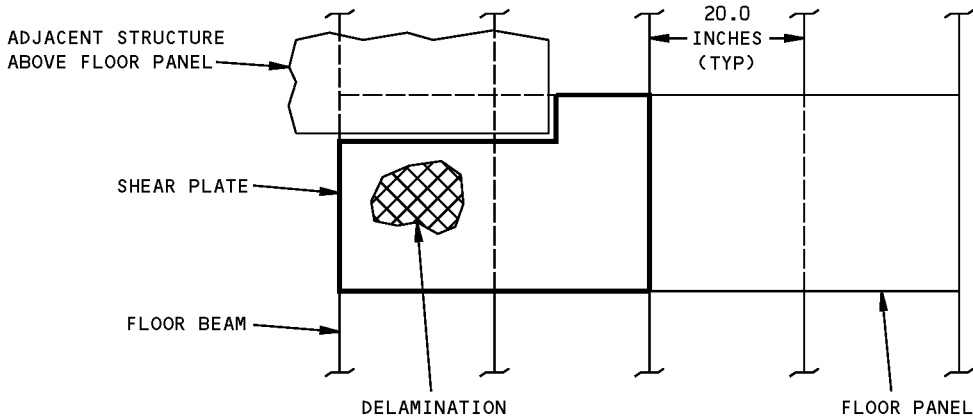
STRUCTURAL REPAIR MANUAL



**DELAMINATION IN CENTER OF PANEL
DETAIL I**



**DELAMINATION NEAR EDGE OF PANEL
DETAIL II**

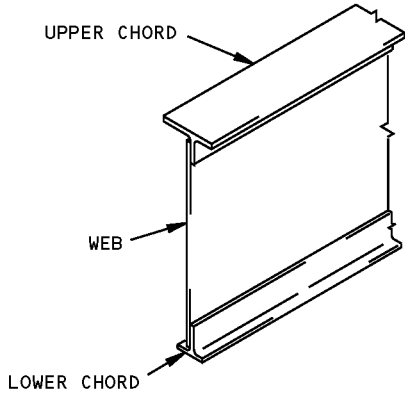


**DELAMINATION NEAR ADJACENT STRUCTURE
DETAIL III**

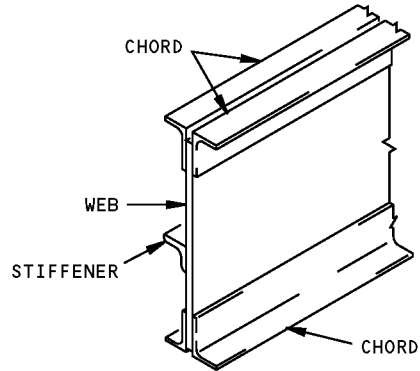
**Floor Panel Repair Limits - Time Limited Repairs
Figure 202**

**757-200
STRUCTURAL REPAIR MANUAL**

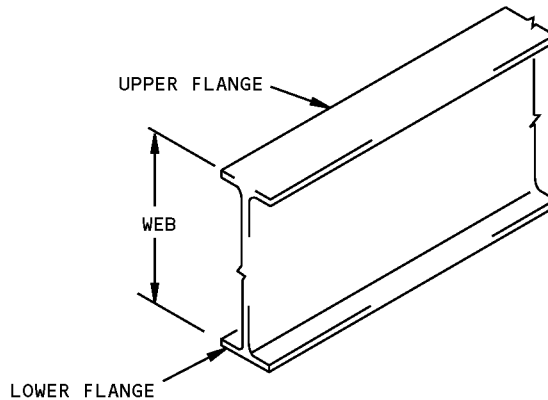
ALLOWABLE DAMAGE 1 - FLOOR STRUCTURE



LONGITUDINAL AND TRANSVERSE FLOOR
BEAMS IN SECTIONS 41 AND 44
BUILT UP



TYPICAL STUB BEAM
BUILT UP



TRANSVERSE FLOOR BEAM
EXTRUDED OR MACHINED

ITEM		CRACKS	NICKS GOUGES CORROSION	DENTS	HOLES
BUILT UP SECTION	UPPER CHORD	A	B	NOT PERMITTED	NOT PERMITTED
	WEB	A	B	C	D
	LOWER CHORD	A	B	NOT PERMITTED	NOT PERMITTED
	STIFFENER	A	B	NOT PERMITTED	NOT PERMITTED
EXTRUDED OR MACHINED BEAM	UPPER FLANGE ^H	A	B	NOT PERMITTED	NOT PERMITTED
	WEB	NOT PERMITTED	B	NOT PERMITTED	NOT PERMITTED
	LOWER FLANGE	A	B	NOT PERMITTED	NOT PERMITTED
DECK PLATE ^I BETWEEN STATIONS 1681.8 AND 1720		A	E	F	D

**Floor Structure Allowable Damage
Figure 101 (Sheet 1 of 3)**

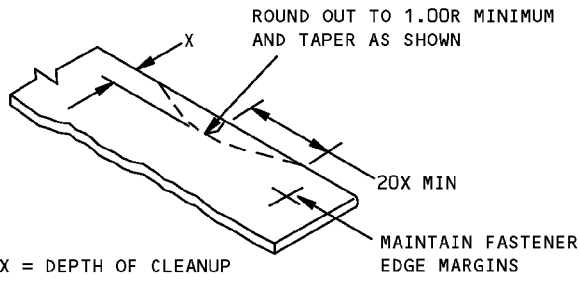
STRUCTURAL REPAIR MANUAL

NOTES

- THIS ALLOWABLE DAMAGE IS A CATEGORY A REPAIR FOR 757-SF AIRPLANES. THE INSPECTIONS GIVEN IN THE MAINTENANCE PLANNING DATA (MPD) AND ASSOCIATED SUPPLEMENT ARE SUFFICIENT TO MAINTAIN THE DAMAGE TOLERANCE OF THE INITIAL STRUCTURE WITH THIS ALLOWABLE DAMAGE. REFER TO SRM 51-00-06 FOR REPAIR CATEGORIES AND DEFINITIONS.
 - ALL DIMENSIONS ARE IN INCHES.
 - REFINISH REWORK AREAS AS GIVEN IN AMM 51-20.
- A** CRACKS ARE NOT ALLOWED EXCEPT FOR EDGE CRACKS WHICH MUST BE REMOVED AS SHOWN IN DETAIL II. MAXIMUM DEPTH OF CLEANED UP AREA IS 0.10 INCH. FASTENER EDGE MARGINS MUST BE MAINTAINED.
- B** EDGE DAMAGE MUST BE REMOVED AS SHOWN IN DETAILS II AND VI. ELSEWHERE DAMAGE MUST BE REMOVED AS SHOWN IN DETAIL III. FASTENER EDGE MARGINS MUST BE MAINTAINED. THE TOTAL CROSS-SECTIONAL AREA REMOVED AS SHOWN IN DETAILS II OR III TO REMOVE NICKS, GOUGES OR CORROSION MUST NOT EXCEED 5 PERCENT OF THE INITIAL CROSS-SECTIONAL AREA OF THE FLANGE OR WEB AS APPROPRIATE. SEE DETAIL IV. THE LIMITATION ON CROSS-SECTIONAL AREA REMOVAL AND THE LIMITATION TO THE DEPTH OF CLEANUP (AS SHOWN IN DETAILS II AND III) MUST BOTH BE SATISFIED.
- C** SMOOTH DENTS THAT ARE FREE FROM CRACKS, GOUGES AND ABRASIONS, AND SHOWING NO EVIDENCE OF PULLED OR LOOSE RIVETS, ARE ALLOWED UP TO 0.125 INCH DEEP PROVIDED THAT A/Y IS NOT LESS THAN 20. SEE DETAIL V.
- D** CLEAN OUT DAMAGE UP TO 0.25 MAX DIA AND NOT CLOSER THAN 1.0 INCH TO FASTENER HOLE, MATERIAL EDGE, OR OTHER DAMAGE. FILL HOLE WITH A 2117-T3 OR T4 ALUMINUM RIVET INSTALLED WET WITH BMS 5-95 SEALANT. ALL OTHERS HOLES MUST BE REPAIRED.
- E** REMOVE EDGE DAMAGE AS SHOWN IN DETAIL II. ELSEWHERE, REMOVE DAMAGE AS SHOWN IN DETAIL III.
- F** SMOOTH DENTS THAT ARE FREE FROM CRACKS, GOUGES AND ABRASIONS, AND SHOWING NO EVIDENCE OF PULLED OR LOOSE RIVETS, ARE ALLOWED UP TO 0.125 INCH DEEP PROVIDED THAT A/Y IS NOT LESS THAN 30. SEE DETAIL V.
- G** THE VERTICAL FLANGE OF THE CHORD IS NOT USED IN THE AREA CALCULATION.
- H** AT BS1681.8 AND BS1701, THE DECK PLATE THICKNESS MUST NOT BE INCLUDED AS PART OF THE UPPER FLANGE THICKNESS OF THE EXTRUDED FLOOR BEAM.
- I** THE THICKNESS OF THE ATTACHED STRUCTURE MUST NOT BE INCLUDED AS PART OF THE DECK PLATE THICKNESS.

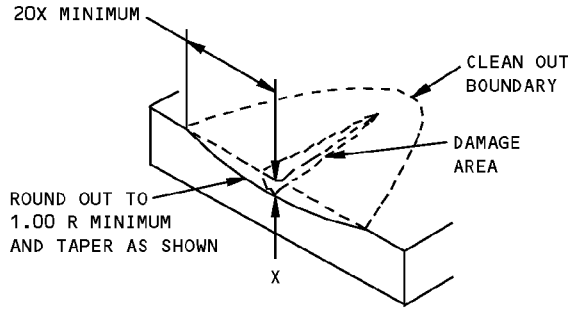
Floor Structure Allowable Damage
Figure 101 (Sheet 2 of 3)

**757-200
STRUCTURAL REPAIR MANUAL**



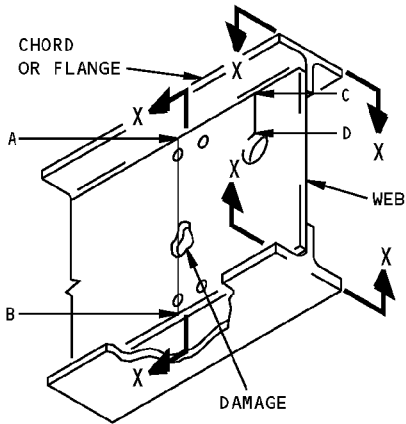
X = DEPTH OF CLEANUP
MUST NOT EXCEED 0.10 INCH

DETAIL II

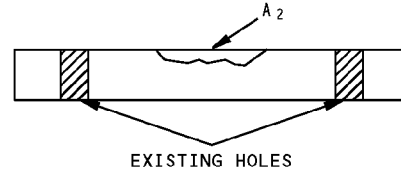


X = DEPTH OF CLEANUP
MUST NOT EXCEED 10% OF GAGE

DETAIL III



LOSS IN CROSS-SECTIONAL AREA ALONG ANY LINE A-B OR C-D DUE TO REMOVAL OF NICKS, GOUGES OR CORROSION PER DETAIL II OR DETAIL III MUST NOT EXCEED 5% OF ORIGINAL NET CROSS-SECTIONAL AREA (SEE SECTION X-X)



A₁ = NET (NON-SHADED AREA) = TOTAL AREA MINUS THE ORIGINAL EXISTING HOLES (SHADED AREA) AS MANUFACTURED

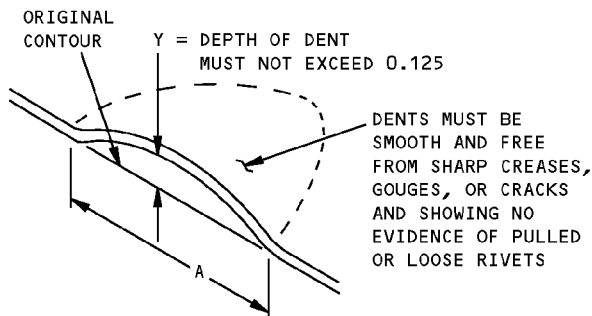
A₂ = AREA REMOVED FOR NICKS, GOUGES, OR CORROSION

$$\left(\frac{A_2}{A_1}\right) = 5\% \text{ MAXIMUM}$$

SECTION X-X [G]

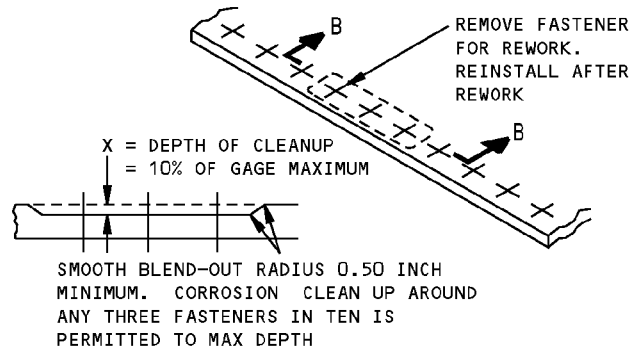
(CHORD OR FLANGE, ROTATED 90° FOR THE WEB)

DETAIL IV



A = WIDTH OF MINOR AXIS OF DENT

DETAIL V



**SECTION B-B
CORROSION CLEANUP**

DETAIL VI

**Floor Structure Allowable Damage
Figure 101 (Sheet 3 of 3)**

STRUCTURAL REPAIR MANUAL

REPAIR 1 - FLOOR BEAM UPPER CHORD UNDER SEAT TRACK REPAIR

APPLICABILITY
THIS REPAIR APPLIES ONLY TO BAC1518-338 TYPE FLOOR BEAMS FROM BS 345 TO BS 880 AND FROM BS 1200 TO BS 1701, EXCEPT AT BS 1681. THIS REPAIR IS NOT APPLICABLE AT SEAT TRACK SPLICE LOCATIONS. E

REPAIR INSTRUCTIONS

1. Remove floor panels and miscellaneous structure to gain access to damaged floor beam.
2. Remove fasteners from existing structure as necessary to facilitate the installation of repair parts. See Details I and II.
3. Remove damaged section of floor beam upper chord. Discard radius fillers at the seat track attach locations. See Details I, II, and III.
4. Trim stabilization structure, if applicable, to facilitate installation of repair parts. See Section C-C.
5. Fabricate repair parts.
6. Preassemble repair parts. Locate and drill fastener holes.
7. Remove parts. Break all sharp edges of new parts and existing structure 0.008.
8. Apply a chemical conversion coating to the repair parts and to the bare surfaces of the initial parts. Refer to SRM 51-20-01.
9. Apply one layer of BMS 10-11, Type 1 primer to the repair parts and to the bare surfaces of the initial parts. Refer to SOPM 20-41-02.
10. Install repair parts with BMS 5-95 sealant between the mating surfaces.
11. Install the fasteners. Fasteners that are not made of aluminum must be installed wet with BMS 5-95 sealant. Refer to SRM 51-20-05.
12. Apply one coat of BMS 10-11, Type 2 enamel to all exposed surfaces in the repair area. **J**
13. Install the clip nuts or nut plates at each hole.
14. Install the structure that was removed to get access to the damaged floor beam. Initial vertical stiffeners on the forward side of the floor beam will have to be installed over the repair angles and possibly need to be trimmed to fit. Use tapered fillers as necessary.

15. Install the floor panels that were removed to get access to the damaged floor beam.
16. Install the floor panel fasteners. Torque the fasteners to 20-25 lb-in.

NOTES

- THIS IS A CATEGORY A REPAIR FOR 757-SF AIRPLANES. THE INSPECTIONS GIVEN IN THE MAINTENANCE PLANNING DATA (MPD) ARE SUFFICIENT TO MAINTAIN THE DAMAGE TOLERANCE OF THE INITIAL STRUCTURE WITH THIS REPAIR INSTALLED. REFER TO SRM 51-00-06 FOR REPAIR CATEGORIES AND DEFINITIONS.
- ALL DIMENSIONS ARE IN INCHES, UNLESS GIVEN DIFFERENTLY
- THE EXTERNAL RADII ON THE REPAIR PARTS MUST BE 0.375 R UNLESS GIVEN DIFFERENTLY
- WHEN YOU USE THIS REPAIR REFER TO:
 - SOPM 20-41-02 FOR THE APPLICATION OF CHEMICAL AND SOLVENT RESISTANCE FINISHES
 - SRM 51-10-00 FOR INVESTIGATION AND CLEAN-UP OF DAMAGE
 - SRM 51-20-01 FOR PROTECTIVE TREATMENT OF METALLIC AND GRAPHITE MATERIALS
 - SRM 51-20-05 FOR REPAIR SEALING
 - SRM 51-40 FOR FASTENER CODE, REMOVAL, INSTALLATION, HOLE SIZES AND EDGE MARGINS.

- A** USE UP TO 1/32 OVERSIZE FASTENER.
- B** SPACE FASTENERS EQUALLY 0.65 TO 0.85. ADJUST FASTENER SPACING TO ACCOMMODATE FLOOR PANEL ATTACH FASTENERS.
- C** TRIM 45°. MAINTAIN FASTENER EDGE MARGIN.
- D** REPAIR PARTS MUST NOT CAUSE BLOCKAGE OF INITIAL HOLES. MAKE THE CUTOUTS IN THE REPAIR PARTS IN THE SAME SHAPE AS THE HOLES THEY MUST GO AROUND IN THE FLOOR BEAM.
- E** REPAIR SHOWN AT BS 460, LBL 24.75. REPAIR FOR BL 45.50 AND OTHER STATIONS SIMILAR.
- F** ADJUST THE REPAIR PART LENGTHS AND THE DISTANCE BETWEEN REPAIR FASTENERS TO INCLUDE THE FLOOR PANEL FASTENER ATTACH LOCATIONS.
- G** THERE MUST BE A MINIMUM OF FOUR REPAIR FASTENERS THROUGH THE ENDS OF EACH FLANGE OF THE PART 2 SUPPORT ANGLE. THIS IS NECESSARY LEFT AND RIGHT OF THE FLOOR CHORD SPLICE.
- H** THERE MUST BE A MINIMUM OF TWO REPAIR FASTENERS THROUGH THE ENDS OF EACH FLANGE OF THE PART 3 SUPPORT ANGLE. THIS IS NECESSARY LEFT AND RIGHT OF THE FLOOR CHORD SPLICE.









**Floor Beam Upper Chord Under Seat Track Repair
Figure 201 (Sheet 1 of 5)**

STRUCTURAL REPAIR MANUAL

NOTES (CONT)

- I** IF THERE IS DOUBLER THAT HOLDS THE AFT FLANGE, INSTALL THE REPAIR STRAPS BELOW THE DOUBLER. IT IS NOT NECESSARY FOR THE STRAPS TO BE IN THE RADIUS OF THE TEE.
- J** FOR ALL OF THE HOLES WHERE THE FLOOR BEAM ATTACHES TO THE FLOOR PANEL:
 1. CLEAN UP THE HOLES.
 2. APPLY ONE LAYER OF BMS 10-11, TYPE 1 PRIMER TO THE HOLE AND THE CLIP NUTS. IT CAN BE NECESSARY TO USE RIVETS TO INSTALL NUT PLATES ON THE REPAIR PARTS IF THE CORRECT CLIP NUTS ARE NOT AVAILABLE. ATTACH THE NUT PLATES WITH TWO BACR15DR3 RIVETS TO STRAP OR ANGLE. REFER TO SOPM 20-41-02.
 3. APPLY ONE LAYER OF MIL-C-11796, CLASS 3 CORROSION INHIBITING COMPOUND IN ALL OF THE HOLES.
- K** BEND THE REPAIR ANGLES IN THE ANNEALED CONDITION, THEN HEAT TREAT AS SPECIFIED.
- L** MAKE THE LENGTH OF THE REPAIR CHORD THE SAME AS THE LENGTH OF THE SHORTER OF THE TWO REINFORCEMENT STRAPS OR THE TWO SUPPORT ANGLES.

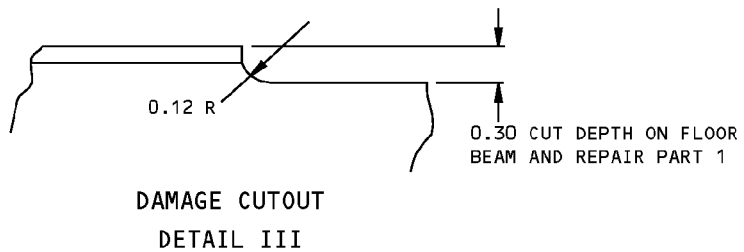
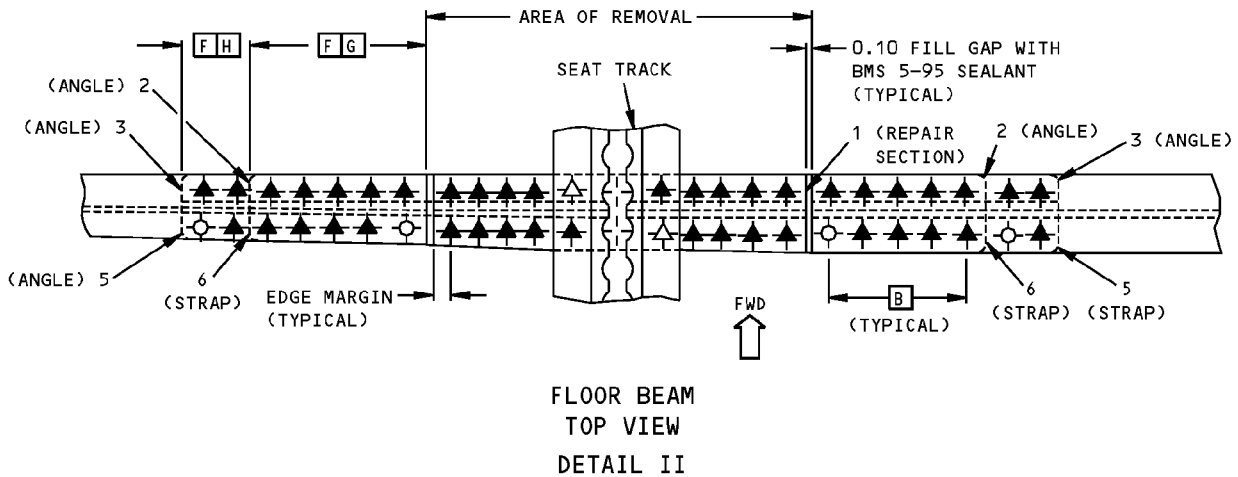
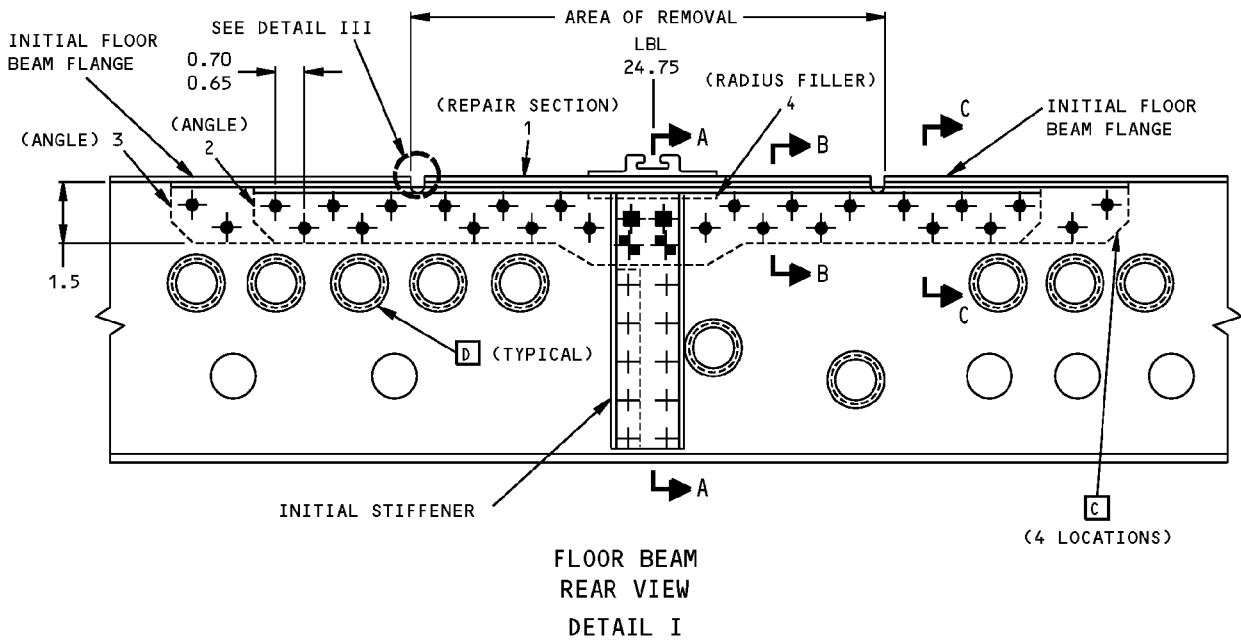
FASTENER SYMBOLS

-  EXISTING FASTENER LOCATION. INSTALL BACB30MY6K HILOK WITH BACC30M6 COLLAR. **A**
-  EXISTING FASTENER LOCATION. INSTALL BACB30NY6K HILOK WITH BACC30X COLLAR. **A**
-  EXISTING FLOOR PANEL ATTACH FASTENER. REPLACE WITH SAME TYPE FASTENER.
-  EXISTING FASTENER LOCATION. INSTALL BACR15FT6D RIVET. **A**
-  REPAIR FASTENER LOCATION. INSTALL BACB30MY6K HILOK WITH BACC30M COLLAR. AS AN ALTERNATIVE, INSTALL A BACB30VT6K HEX DRIVE BOLT WITH A BACC30BL COLLAR.
-  EXISTING FASTENER LOCATION. INSTALL BACB30MY8K HILOK WITH BACC30M COLLAR. **A**
-  REPAIR FASTENER LOCATION. INSTALL BACB30NY6K HILOK WITH BACC30X COLLAR.
-  EXISTING FASTENER LOCATION. INSTALL SAME TYPE AS REMOVED.

REPAIR MATERIAL			
PART		QTY	MATERIAL
1	REPAIR SECTION	1	BAC1505-100617 L 7075-T73
2	SUPPORT ANGLE	1	0.071 CLAD 7075-0 K HT TR T0-T6 AS AN ALTERNATIVE, USE BAC1490-2865 7075-T6
3	SUPPORT ANGLE	1	0.063 CLAD 7075-0 K HT TR T0-T6 AS AN ALTERNATIVE, USE BAC1490-2734 7075-T6
4	RADIUS FILLER	1	BAC1512-426 7075-T6
5	REINFORCEMENT STRAP	1	0.063 CLAD 7075-T6
6	REINFORCEMENT STRAP	1	0.071 CLAD 7075-T6 AS AN ALTERNATIVE, USE BAC1512-3345 7075-T6
7	CLIP	1	0.063 CLAD 7075-T6

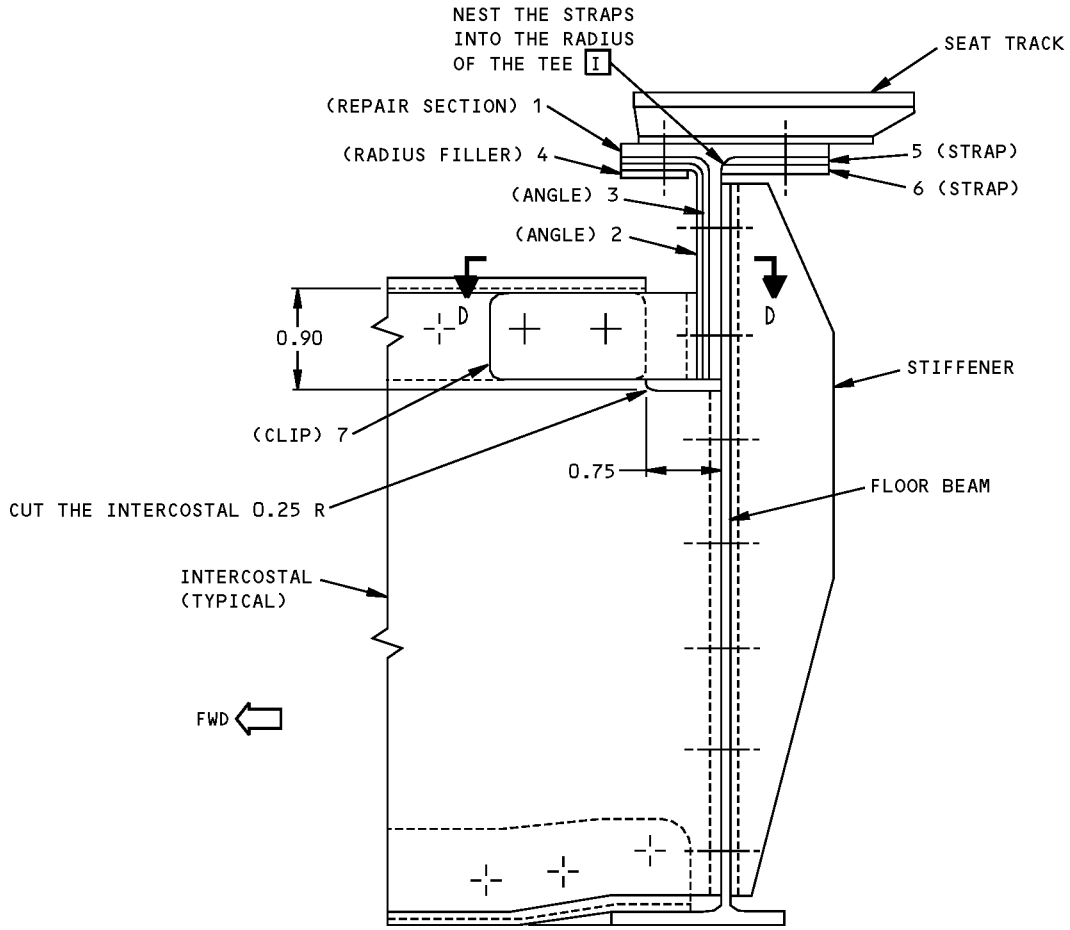
Floor Beam Upper Chord Under Seat Track Repair
Figure 201 (Sheet 2 of 5)

**757-200
STRUCTURAL REPAIR MANUAL**

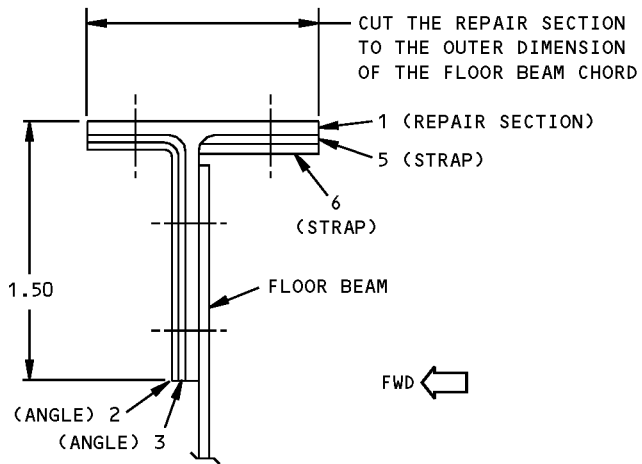


**Floor Beam Upper Chord Under Seat Track Repair
Figure 201 (Sheet 3 of 5)**

**757-200
STRUCTURAL REPAIR MANUAL**



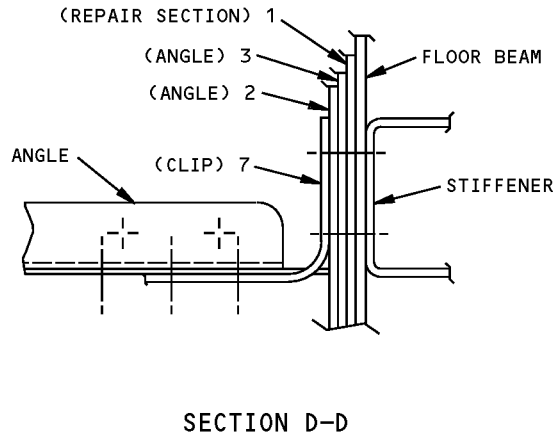
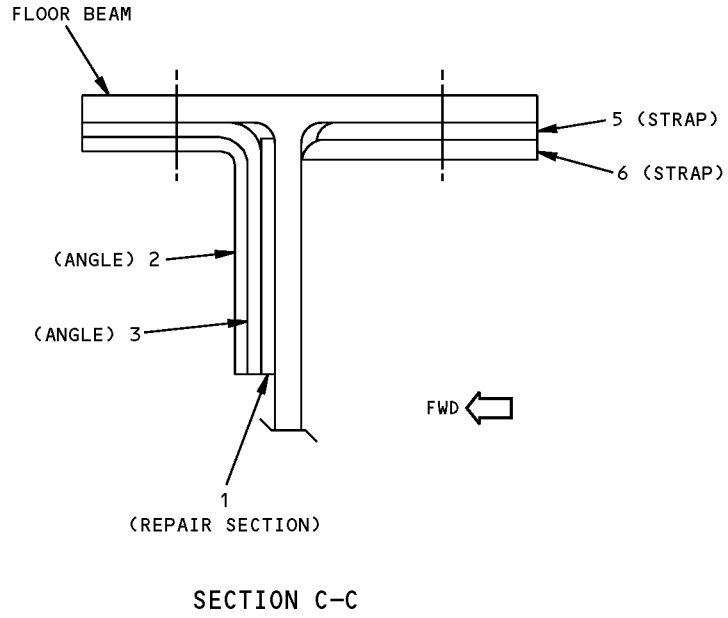
SECTION A-A



SECTION B-B

**Floor Beam Upper Chord Under Seat Track Repair
Figure 201 (Sheet 4 of 5)**

**757-200
STRUCTURAL REPAIR MANUAL**



**Floor Beam Upper Chord Under Seat Track Repair
Figure 201 (Sheet 5 of 5)**

STRUCTURAL REPAIR MANUAL

REPAIR 2 - FLOOR BEAM UPPER CHORD REPAIR AT BS 1681

APPLICABILITY
THIS REPAIR IS APPLICABLE ONLY TO BAC1518-827 TYPE FLOOR BEAMS AT BS 1681.8. DO NOT USE THIS REPAIR IF THE DAMAGE IS LARGER THAN 30% OF THE INITIAL AREA OF THE CROSS SECTION OF THE FLANGE. IF THE DAMAGE IS LARGER THAN 30% OF THE AREA OF THE CROSS SECTION OF THE FLANGE, TELL THE BOEING COMPANY.

REPAIR INSTRUCTIONS

1. Remove the floor panels and the necessary structure to get access to the damaged floor beam.
2. Remove the fasteners from the initial structure as necessary to make the installation of the repair parts easier.
3. Remove the damaged part of the floor beam upper chord.
4. Cut the floor beam stabilization structure, if necessary, to make the installation of the repair parts easier.
5. Make the repair parts. See Table I.
6. Assemble the repair parts and drill the fastener holes.
7. Disassemble the repair parts.
8. Remove the nicks, scratches, gouges, burrs, and sharp edges from the repair parts and initial parts.
9. Apply a chemical conversion coating to the repair parts and to the bare surfaces of the initial parts. Refer to SRM 51-20-01.
10. Apply one layer of BMS 10-11, Type 1 primer to the repair parts and to the bare surfaces of the initial parts. Refer to SOPM 20-41-02.
11. Fill the damaged area that was blended out with BMS 5-92, Type I or Type III adhesive. This will give a flush surface for the repair angles and straps.
12. Install the repair parts with BMS 5-95 sealant between the mating surfaces.
13. Install the fasteners. Fasteners that are not made of aluminum must be installed wet with BMS 5-95 sealant. Refer to SRM 51-20-5.
14. Apply one layer of BMS 10-11, Type 2 enamel to the repair parts and to the initial parts in the repair area. **D**
15. Install the clip nuts or nutplates.
16. Install the structure that was removed to get access to the damaged floor beam.

17. Install the floor panels that were removed to get access to the damaged floor beam.
18. Install the floor panel fasteners. Torque the fasteners 20-25 lb-in.

NOTES

- THIS IS A CATEGORY A REPAIR FOR 757-SF AIRPLANES. THE INSPECTIONS GIVEN IN THE MAINTENANCE PLANNING DATA (MPD) ARE SUFFICIENT TO MAINTAIN THE DAMAGE TOLERANCE OF THE INITIAL STRUCTURE WITH THIS REPAIR INSTALLED. REFER TO SRM 51-00-06 FOR REPAIR CATEGORIES AND DEFINITIONS.
- THE DIMENSIONS ARE IN INCHES UNLESS GIVEN DIFFERENTLY.
- WHEN YOU USE THIS REPAIR REFER TO:
 - AMM 51-21 FOR INTERIOR AND EXTERIOR FINISHES
 - SOPM 20-41-02 FOR THE APPLICATION OF CHEMICAL AND SOLVENT RESISTANT FINISHES
 - SRM 51-10-00 FOR INVESTIGATION AND CLEANUP OF DAMAGE
 - SRM 51-20-01 FOR PROTECTIVE TREATMENT OF METAL
 - SRM 51-20-05 FOR REPAIR SEALING
 - SRM 51-40 FOR FASTENER CODE, REMOVAL, INSTALLATION, HOLE SIZES AND EDGE MARGINS.

- A** THE DISTANCE BETWEEN THE FASTENERS MUST BE EQUAL. THIS DISTANCE CAN BE FROM 0.65 INCH TO 0.85 INCH. THERE MUST BE SUFFICIENT CLEARANCE WITH THE FASTENERS THAT ATTACH THE FLOOR PANEL TO THE FLOOR STRUCTURE. CHANGE THE DISTANCE BETWEEN THESE FASTENERS, IF NECESSARY, TO DO THIS.
- B** CUT THIS AT 45 DEGREES. KEEP THE FASTENER EDGE MARGIN.
- C** THE REPAIR PARTS MUST NOT CAUSE A BLOCKAGE OF THE INITIAL HOLES.
- D** FOR ALL OF THE HOLES WHERE THE FLOOR BEAM ATTACHES TO THE FLOOR PANEL:
 1. CLEAN UP THE HOLES.
 2. APPLY ONE LAYER OF BMS 10-11, TYPE 1 PRIMER TO THE HOLE AND THE CLIP NUTS. IT CAN BE NECESSARY TO USE RIVETS TO INSTALL NUTPLATES ON THE REPAIR PARTS IF THE CORRECT CLIP NUTS ARE NOT AVAILABLE.
 3. APPLY ONE LAYER OF MIL-C-11796, CLASS 3 CORROSION INHIBITING COMPOUND IN ALL OF THE HOLES.

**Floor Beam Upper Chord Repair at BS 1681
Figure 201 (Sheet 1 of 3)**

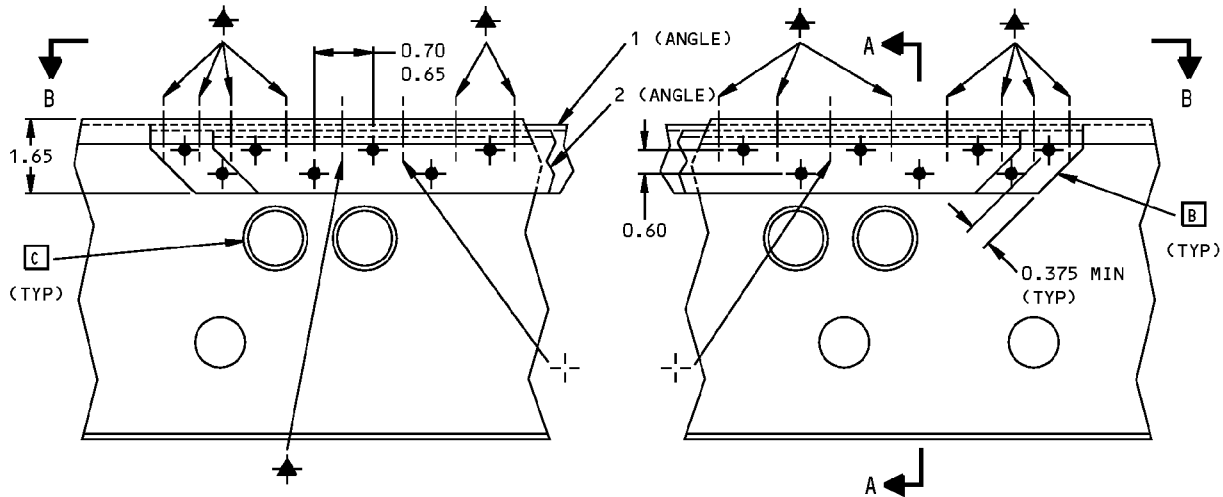
**757-200
STRUCTURAL REPAIR MANUAL**

FASTENER SYMBOLS

- + INITIAL FLOOR PANEL ATTACHMENT LOCATION. INSTALL THE SAME TYPE AND SIZE FASTENER AS THE INITIAL FASTENER THAT WAS REMOVED.
- ◆ REPAIR FASTENER LOCATION. INSTALL A BACB30MY6K HEX DRIVE BOLT WITH A BACC30M COLLAR. AS AN ALTERNATIVE, INSTALL A BACB30VT6K HEX DRIVE BOLT WITH A BACC30BL COLLAR.
- ▲ REPAIR FASTENER LOCATION. INSTALL A BACB30NY6K HEX DRIVE BOLT WITH A BACC30X COLLAR.

REPAIR MATERIAL			
PART		QTY	MATERIAL
1	ANGLE	1	BAC1490-2720 7075-T6
2	ANGLE	1	BAC1490-2720 7075-T6
3	STRAP	1	0.040 X 1.0 7075-T6
4	STRAP	1	0.040 X 1.0 7075-T6

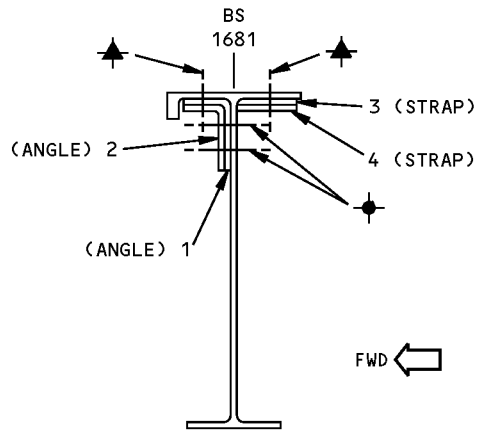
TABLE I



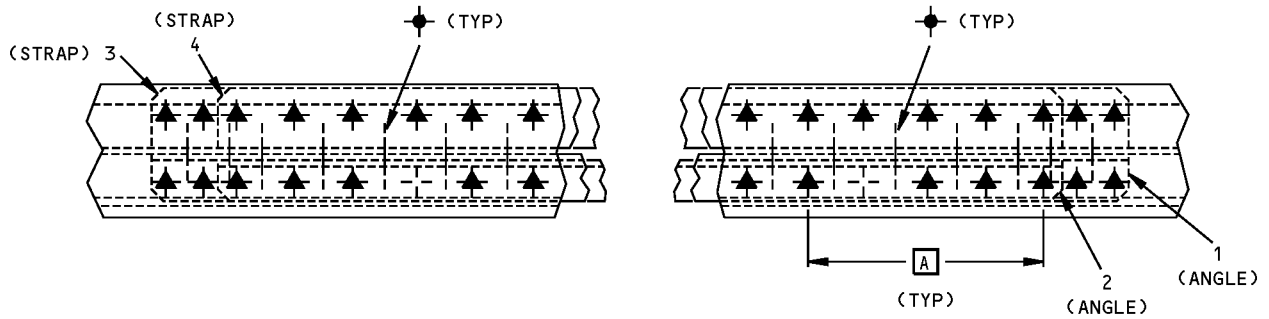
DETAIL I

**Floor Beam Upper Chord Repair at BS 1681
Figure 201 (Sheet 2 of 3)**

**757-200
STRUCTURAL REPAIR MANUAL**



SECTION A-A



VIEW B-B

**Floor Beam Upper Chord Repair at BS 1681
Figure 201 (Sheet 3 of 3)**

STRUCTURAL REPAIR MANUAL**REPAIR 3 - FLOOR BEAM UPPER CHORD REPAIR AWAY FROM A SEAT TRACK****APPLICABILITY**

THIS REPAIR IS APPLICABLE TO DAMAGE ON THE UPPER CHORD OF BAC1518-338 FLOOR BEAMS FROM BS 345 TO BS 880 AND FROM BS 1200 TO BS 1701, EXCEPT AT BS 1681. THIS REPAIR IS NOT APPLICABLE TO DAMAGE FOUND AT A SEAT TRACK.

REPAIR INSTRUCTIONS

1. Remove floor panels and other structure as necessary to get access to the damaged floor beam. Remove the fasteners from the repair area as necessary to make the installation of the repair parts easier.
2. Cut and remove the damaged part of the floor beam upper chord. See Detail I.
3. Make the repair parts. See Table I.
4. Assemble the repair parts and drill the fastener holes. Fastener hole diameters at the floor panel fastener locations must be 0.250 to 0.261 inches.
5. Disassemble the repair parts.
6. Remove the nicks, scratches, gouges, burrs, and sharp edges from the repair parts and the floor beam.
7. Apply a chemical conversion coating to the repair parts and to the bare surfaces of the floor beam. Refer to SRM 51-20-01.
8. Apply one layer of BMS 10-11, Type I primer to the repair parts and to the bare surfaces of the floor beam. Refer to SOPM 20-41-02.
9. Install the repair parts with BMS 5-95 sealant between the mating surfaces.
10. Install the fasteners wet with BMS 5-95 sealant. Refer to SRM 51-20-05.
11. Apply one layer of BMS 10-11, Type II enamel, color 702 white gloss to all of the surfaces in the repair area where you have applied primer.
12. Install the adjacent structure which was removed to get access to the damaged area. Initial vertical stiffeners on the forward side of the floor beam will have to be reinstalled over the repair angles and possibly need to be trimmed to fit. Use tapered fillers as necessary.
13. Install the floor panels which were removed to get access to the damaged area. The following steps apply to all of the holes common to the floor panel attachments.
 - A. Clean up the holes.
 - B. Apply one layer of BMS 10-11, Type I primer to the holes and clipnuts. It can be necessary to use rivets to install nutplates on the repair parts if the correct clip-on nuts are not available. Attach the nutplates with two BACR15DR3 rivets to the strap or angle. Refer to SOPM 20-41-02.
 - C. Apply one layer of MIL-C-11796, Class 3 corrosion inhibiting compound in all of the holes.
 - D. Install a clip-on nut or nutplate at each hole.
 - E. Install the floor panel fasteners and torque to 20-25 in-lb.

**Floor Beam Upper Chord Repair Away From a Seat Track
Figure 201 (Sheet 1 of 5)**

STRUCTURAL REPAIR MANUAL

NOTES

- THIS IS A CATEGORY A REPAIR FOR 757-SF AIRPLANES. THE INSPECTIONS GIVEN IN THE MAINTENANCE PLANNING DATA (MPD) ARE SUFFICIENT TO MAINTAIN THE DAMAGE TOLERANCE OF THE INITIAL STRUCTURE WITH THIS REPAIR INSTALLED. REFER TO SRM 51-00-06 FOR REPAIR CATEGORIES AND DEFINITIONS.
- IF THE REPAIR PARTS EXTEND UNDER A SEAT TRACK IT CAN BE NECESSARY TO DO THE REPAIR GIVEN IN SRM 53-00-51, REPAIR 1.
- ALL DIMENSIONS ARE IN INCHES, UNLESS GIVEN DIFFERENTLY.
- WHEN YOU USE THIS REPAIR REFER TO:
 - SOPM 20-41-02 FOR APPLICATION OF CORROSION RESISTANT PRIMER
 - SRM 51-20-01 FOR PROTECTIVE TREATMENT OF METALLIC AND GRAPHITE MATERIALS
 - SRM 51-10-02 FOR INSPECTION AND REMOVAL OF DAMAGE
 - SRM 51-20-05 FOR REPAIR SEALING
 - SRM 51-40 FOR FASTENER CODE, INSTALLATION AND REMOVAL, HOLE SIZES, AND EDGE MARGINS.

- A** THE EXTERNAL RADII ON THE REPAIR PARTS MUST BE 0.375 INCH (10 mm) RAD UNLESS GIVEN DIFFERENTLY.
- B** BEND THE REPAIR ANGLES IN THE ANNEALED CONDITION, THEN HEAT TREAT AS SPECIFIED.
- C** THE REPAIR PARTS MUST NOT CAUSE BLOCKAGE OF ANY FLOOR BEAM HOLES. MAKE THE CUTOUTS IN THE REPAIR PARTS THE SAME SHAPE AS THE HOLES THEY MUST GO AROUND IN THE FLOOR BEAM.
- D** ADJUST THE REPAIR PART LENGTHS AND THE DISTANCE BETWEEN REPAIR FASTENERS TO INCLUDE THE FLOOR PANEL FASTENER ATTACH LOCATIONS.
- E** FILL THE DISTANCE BETWEEN PARTS WITH BMS 5-95 SEALANT.
- F** THERE MUST BE A MINIMUM OF FOUR REPAIR FASTENERS THROUGH THE ENDS OF EACH FLANGE OF THE PART 3 SUPPORT ANGLE. THIS IS NECESSARY LEFT AND RIGHT OF THE FLOOR CHORD SPLICE.
- G** THERE MUST BE A MINIMUM OF TWO REPAIR FASTENERS THROUGH THE ENDS OF EACH FLANGE OF THE PART 2 SUPPORT ANGLE. THIS IS NECESSARY LEFT AND RIGHT OF THE FLOOR CHORD SPLICE.

- H** USE UP TO 1/32 OVERSIZE FASTENERS TO REPLACE INITIAL FASTENERS THROUGH FLOOR BEAMS THAT ATTACH A DOUBLER TO THE AFT FLANGE.
- I** IF THERE IS AN INITIAL DOUBLER THAT HOLDS THE AFT FLANGE, INSTALL THE REPAIR STRAPS BELOW THE DOUBLER. IT IS NOT NECESSARY FOR THE STRAPS TO BE IN THE RADIUS OF THE TEE.

FASTENERS SYMBOLS

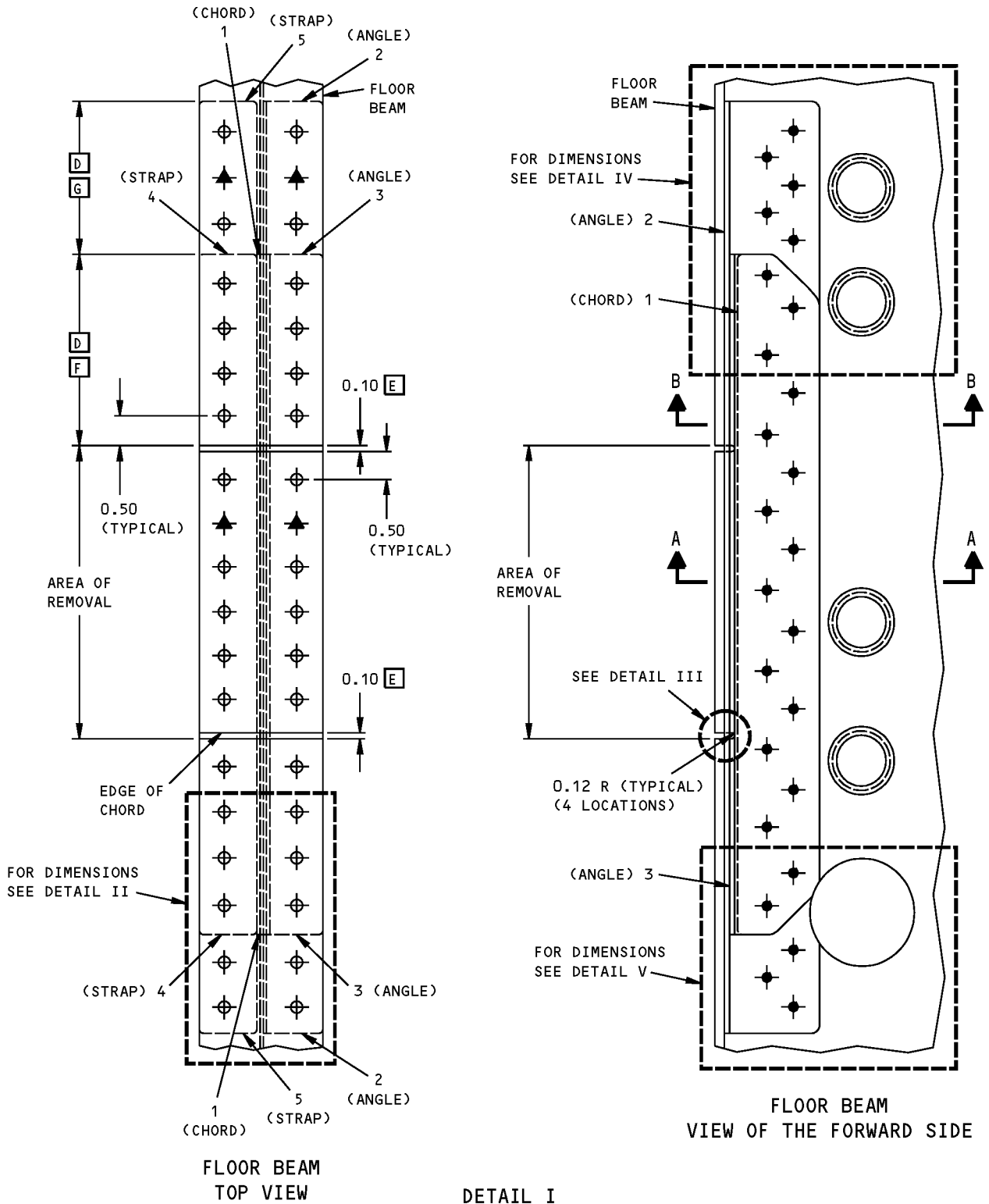
- ✦ REPAIR FASTENER LOCATION. INSTALL A BACB30MY6K BOLT AND A BACC30M6 COLLAR. AS AN ALTERNATIVE, INSTALL A BACB30VT6K() BOLT AND A BACC30BL COLLAR. INSTALL THE FASTENER IN A 0.187-0.190 INCH DIAMETER HOLE. **H**
- ✦ FLOOR PANEL FASTENER LOCATION. INSTALL A BACN10YD6G CLIP-ON NUT OR BACN10JR3CFD NUTPLATE AND THE SAME TYPE AND SIZE FLOOR PANEL FASTENER AS THE ONE THAT WAS REMOVED.
- ⊕ REPAIR FASTENER LOCATION. INSTALL A BACB30NW6K BOLT AND A BACC30M6 COLLAR. AS AN ALTERNATIVE, INSTALL A BAC30VU6K() BOLT AND A BACC30BL COLLAR. INSTALL THE FASTENER IN A 0.187-0.190 INCH DIAMETER HOLE. **H**

REPAIR MATERIAL			
	PART	QTY	MATERIAL
1	CHORD	1	BAC1505-100617 7075-T73
2	ANGLE	1	0.063 CLAD 7075-0 B HT TR TO -T6 AS AN ALTERNATIVE, USE BAC1490-2734 7075-T6
3	ANGLE	1	0.071 CLAD 7075-0 B HT TR TO -T6 AS AN ALTERNATIVE, USE BAC1490-2865 7075-T6
4	STRAP	1	0.071 CLAD 7075-T6 AS AN ALTERNATIVE, USE BAC1512-3345 7075-T6
5	STRAP	1	0.063 CLAD 7075-T6

TABLE I

**Floor Beam Upper Chord Repair Away From a Seat Track
Figure 201 (Sheet 2 of 5)**

STRUCTURAL REPAIR MANUAL



**Floor Beam Upper Chord Repair Away From a Seat Track
Figure 201 (Sheet 3 of 5)**

DETAIL I

FLOOR BEAM
TOP VIEW

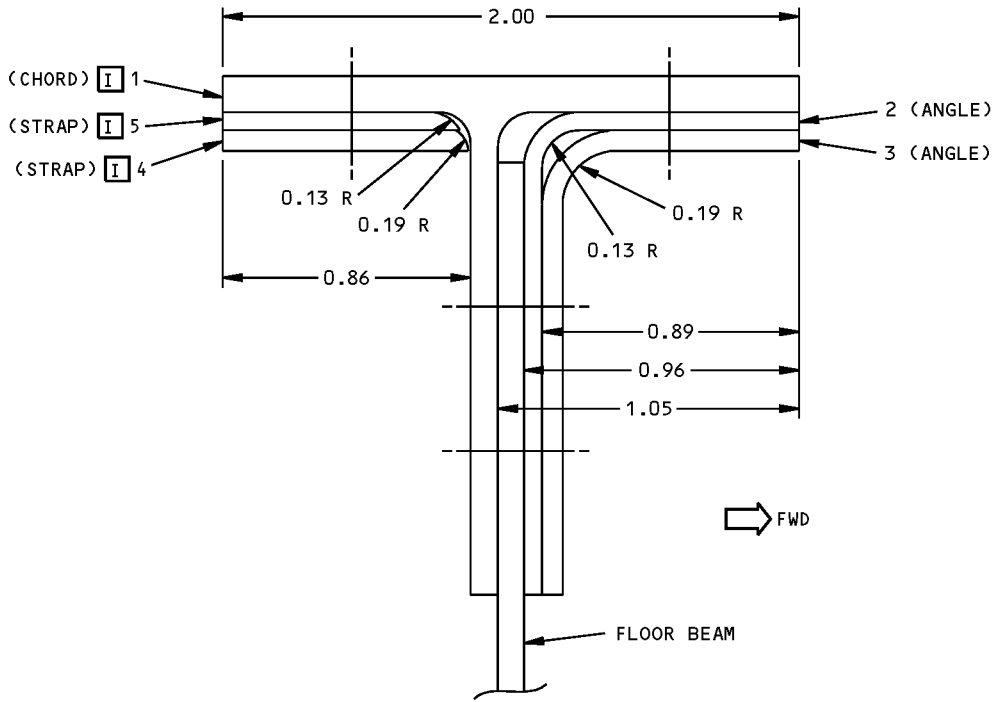
FLOOR BEAM
VIEW OF THE FORWARD SIDE

53-00-51

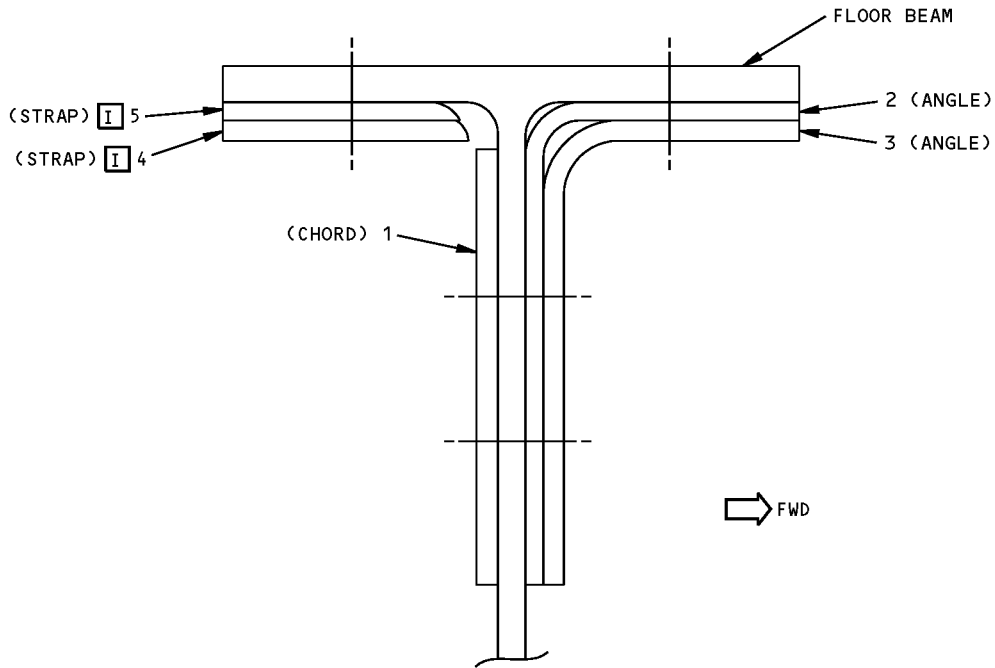
REPAIR 3
Page 203
Jan 20/2005

D634N201

**757-200
STRUCTURAL REPAIR MANUAL**



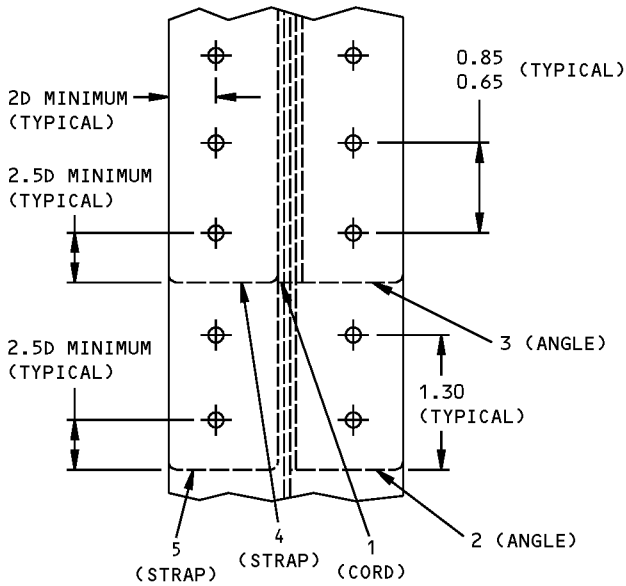
SECTION A-A



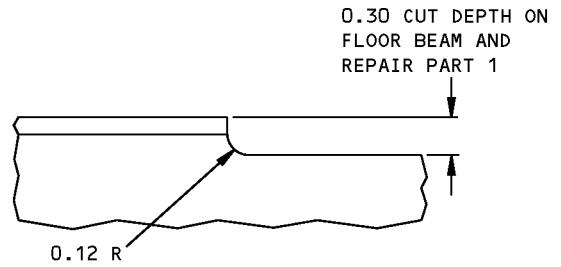
SECTION B-B

**Floor Beam Upper Chord Repair Away From a Seat Track
Figure 201 (Sheet 4 of 5)**

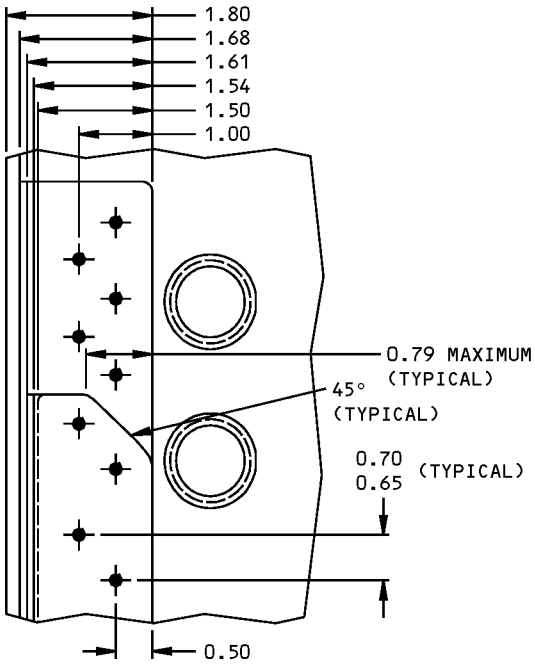
STRUCTURAL REPAIR MANUAL



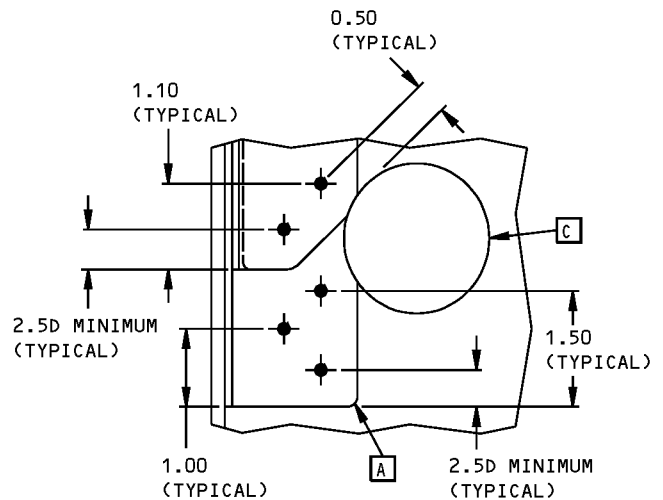
DETAIL II



DAMAGE CUTOUT
DETAIL III



DETAIL IV



DETAIL V

Floor Beam Upper Chord Repair Away From a Seat Track
Figure 201 (Sheet 5 of 5)

STRUCTURAL REPAIR MANUAL

REPAIR 4 - FLOOR STRUCTURE - INTERCOSTAL UPPER CHORD GENERAL REPAIR

APPLICABILITY D

FOR THE INTERCOSTAL REPAIR BETWEEN STATIONS 1661 AND 1681.8 AT RBL 10.27 AND WL 208.1, REFER TO SRM 53-60-51, FIGURE 202. THIS REPAIR APPLIES TO DAMAGE TO THE UPPER CHORD OF THE OTHER INTERCOSTALS AT WL 208.1 IN SECTIONS 43 AND 46. REPLACEMENT OF THE UPPER CHORD IS NECESSARY IN THIS REPAIR. THIS REPAIR DOES NOT APPLY TO INTERCOSTALS USED FOR EQUIPMENT HARDPOINT INSTALLATION.

REPAIR INSTRUCTIONS

1. Remove the floor panels and other structure to get access to the floor beams, gusset and intercostal angle.
2. Remove all the initial fasteners from the repair area. See Detail I.
3. Remove and discard the damaged angle.
4. Make the repair parts. See Table I.
5. Assemble the repair parts and drill the initial fastener hole locations and the repair fastener locations. A B
6. Disassemble the repair parts.
7. Remove the nicks, scratches, gouges, burrs and sharp edges from the repair parts and the initial parts.
8. Apply a chemical conversion coating to the repair parts and to the bare surfaces of the initial parts. Refer to SRM 51-20-01.
9. Apply one layer of BMS 10-11, Type I primer to the repair parts and to the bare surfaces of the initial parts. Refer to SOPM 20-41-02.
10. Install the floor panel attachments with BACR15DR3 blind rivets and BACN10JR3CFD nutplates through the repair angle only. Install the rivets wet with BMS 5-95 sealant. B
11. Install the repair parts with BMS 5-95 sealant between the mating surfaces. Refer to SRM 51-20-05.
12. Install the repair fasteners at the initial and repair locations.
13. Apply a layer of BMS 10-11, Type II enamel to the repair area. Refer to SOPM 20-41-02.

NOTE: As an option, apply one layer of BMS 10-11, Type I primer.

NOTES

- ALL DIMENSIONS ARE IN INCHES UNLESS GIVEN DIFFERENTLY.
- D = THE DIAMETER OF THE FASTENER
- WHEN YOU USE THIS REPAIR REFER TO:
 - SOPM 20-41-02 FOR APPLICATION OF FINISHES
 - SRM 51-20-01 FOR PROTECTIVE TREATMENT OF METAL
 - SRM 51-10-02 FOR INSPECTION AND REMOVAL OF DAMAGE
 - SRM 51-20-05 FOR SEALING OF REPAIRS
 - SRM 51-40 FOR FASTENER CODE, REMOVAL AND INSTALLATION, HOLE SIZES AND EDGE MARGINS.

- A MAKE SURE THE INITIAL FASTENER HOLE LOCATIONS IN THE REPAIR ANGLE ARE LOCATED BY THE FASTENER HOLES IN THE FLOOR PANEL. MAKE SURE THE REPAIR FASTENER EDGE MARGIN IS A MINIMUM OF 2D AND FASTENER SPACING IS A MAXIMUM OF 2.0 INCHES (50 mm).
- B DRILL THE FASTENER HOLES FOR THE BACR15DR3 RIVETS THROUGH THE REPAIR ANGLE ONLY.
- C IF NECESSARY, INSTALL A 1/32 INCH OVERSIZE FASTENER OF THE SAME TYPE AS THE INITIAL FASTENER.
- D FOR PASSENGER AIRPLANES ONLY.

FASTENER SYMBOLS

- REFERENCE FASTENER LOCATION
- INITIAL FASTENER LOCATION. INSTALL BACR15FT5D RIVETS. C
- INITIAL FASTENER LOCATION. INSTALL BACR15CE5D RIVETS.
- REPAIR FASTENER LOCATION. INSTALL BACR15CE5D RIVETS.
- INITIAL FASTENER LOCATION. INSTALL A BACN10JR3CFD NUTPLATE WITH TWO BACR15DR3 RIVETS. B

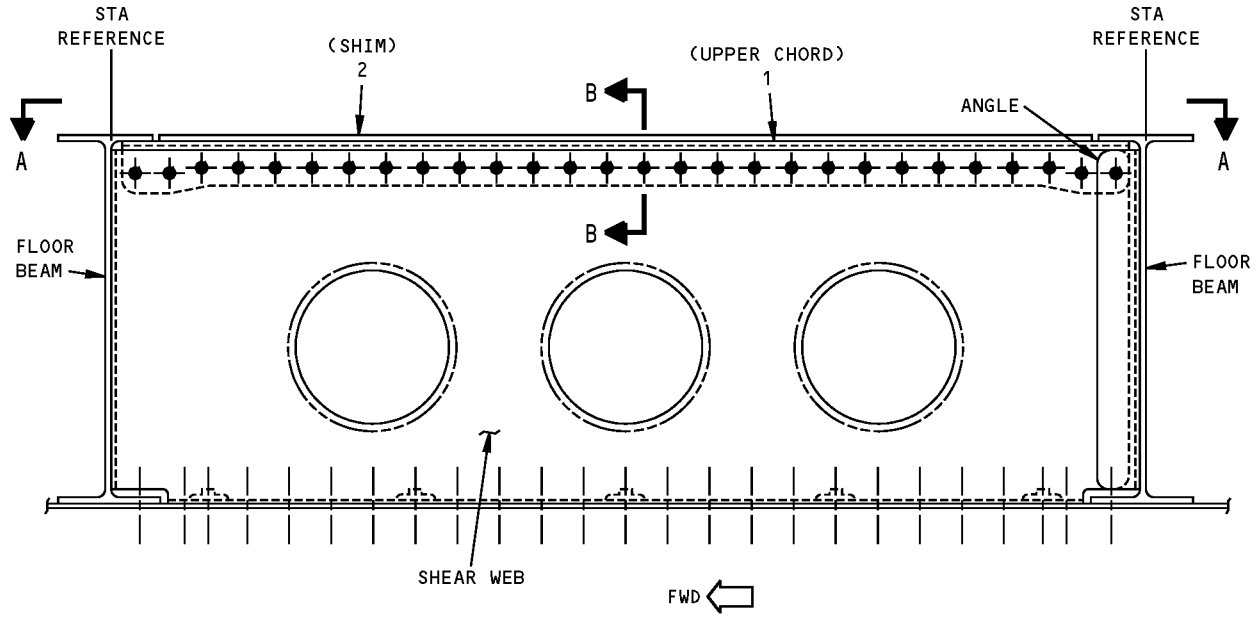
REPAIR MATERIAL

PART		QTY	MATERIAL
1	ANGLE	1	USE THE SAME MATERIAL, HEAT TREAT, DIMENSIONS AND GAGE AS THE INITIAL ANGLE.
2	SHIM	AS REQ'D	7075-T6 (THICKNESS AS REQUIRED)

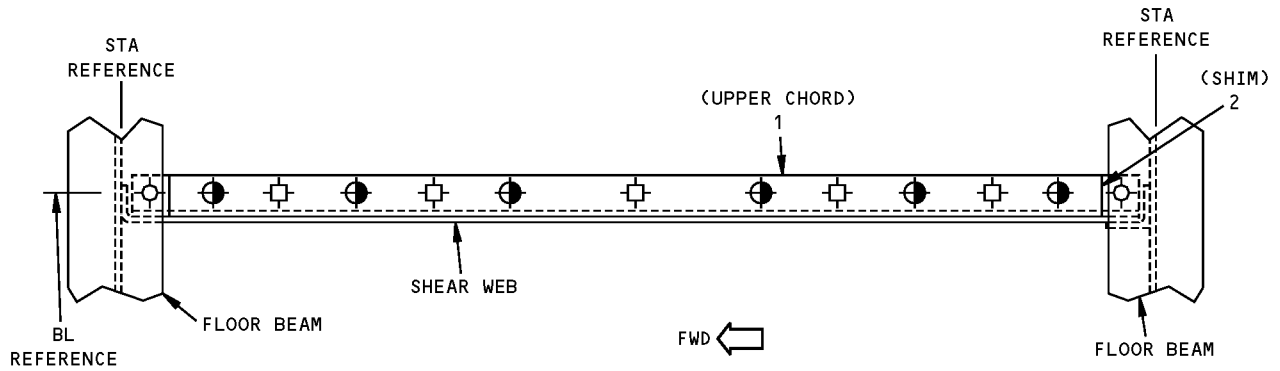
TABLE I

**Floor Structure - Intercostal Upper Chord General Repair
Figure 201 (Sheet 1 of 2)**

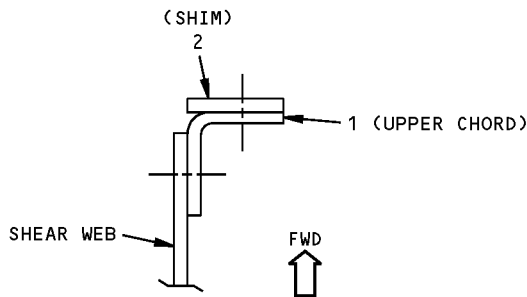
**757-200
STRUCTURAL REPAIR MANUAL**



DETAIL I



VIEW A-A



SECTION B-B

**Floor Structure - Intercostal Upper Chord General Repair
Figure 201 (Sheet 2 of 2)**

STRUCTURAL REPAIR MANUAL

REPAIR 5 - REPAIR TO ONE FLANGE OF THE FLOOR BEAM UPPER OR LOWER CHORD

APPLICABILITY
<p>THIS REPAIR IS APPLICABLE TO DAMAGE ON ONE FLANGE OF THE UPPER OR LOWER CHORD OF BAC1518-338 FLOOR BEAMS FROM BS 345 TO BS 880 AND FROM BS 1200 TO BS 1701, EXCEPT AT BS 1681. DO NOT USE THIS REPAIR ON FLOOR BEAMS REINFORCED WITH A CHORD DOUBLER. THIS REPAIR IS NOT APPLICABLE TO DAMAGE FOUND AT A SEAT TRACK OR IN THE TAPERED AREAS OF THE FLOOR BEAM CHORD.</p>

REPAIR INSTRUCTIONS

1. Remove the floor panels and other adjacent structure as necessary to get access to the damaged floor beam.
2. Cut and remove the damaged part of the floor beam chord. Refer to Detail I.
3. Make the repair parts. Refer to Table I.
4. Assemble the repair parts and drill the fastener holes.
5. Disassemble the repair parts.
6. Remove the nicks, scratches, gouges, burrs, and sharp edges from the repair parts and the floor beam.
7. Apply a chemical conversion coating to the repair parts and to the bare surfaces of the floor beam. Refer to SRM 51-20-01.
8. Apply two layers of BMS 10-11, Type I primer to the repair parts and to the bare surfaces of the floor beam. Refer to SOPM 20-41-02.
9. Install BACN10KE3 nutplates to the repair angle at floor panel fastener locations. Install the nutplate with BACR15BA3AD rivets.
10. Install the repair parts with BMS 5-95 sealant between the mating surfaces.
11. Install the fasteners wet with BMS 5-95 sealant. Refer to SRM 51-20-05.
12. (This step is optional). Apply one layer of BMS 10-11, Type II enamel, color 702 white gloss to the exposed surface. Refer to SOPM 20-41-02.
13. Install the adjacent structure which was removed to get access to the damaged area. Initial vertical stiffeners on the floor beam web will have to be reinstalled over the repair angles and possibly need to be trimmed to fit. Use the part 5 shims as necessary.
14. Install the floor panels which were removed to get access to the damaged area. Refer to Refer to AMM 53-01.
15. Apply a layer of BMS 3-23 corrosion inhibiting compound to the repaired area. SRM 51-20-01.

NOTES

- THIS IS A CATEGORY A REPAIR FOR 757-SF AIRPLANES. THE INSPECTIONS GIVEN IN THE MAINTENANCE PLANNING DATA (MPD) ARE SUFFICIENT TO MAINTAIN THE DAMAGE TOLERANCE OF THE INITIAL STRUCTURE WITH THIS REPAIR INSTALLED. REFER TO SRM 51-00-06 FOR REPAIR CATEGORIES AND DEFINITIONS.
- ALL DIMENSIONS ARE IN INCHES, UNLESS GIVEN DIFFERENTLY.
- D = FASTENER DIAMETER
- INSTALL FASTENERS WITH 4D-6D SPACING.
- WHEN YOU USE THIS REPAIR REFER TO:
 - SOPM 20-41-02 FOR APPLICATION OF CHEMICAL AND SOLVENT RESISTANT FINISHES
 - SRM 51-20-01 FOR PROTECTIVE TREATMENT OF METALLIC AND GRAPHITE MATERIALS
 - SRM 51-10-02 FOR INSPECTION AND REMOVAL OF DAMAGE
 - SRM 51-20-05 FOR REPAIR SEALING
 - SRM 51-40 FOR FASTENER CODE, INSTALLATION AND REMOVAL, HOLE SIZES, AND EDGE MARGINS.

- A** THERE MUST BE A MINIMUM OF THREE REPAIR FASTENERS THROUGH THE PART 3 ANGLE AND THE INITIAL FLOOR BEAM CHORD.
- B** THERE MUST BE A MINIMUM OF FOUR REPAIR FASTENERS THROUGH THE PART 2 ANGLE AND THE INITIAL FLOOR BEAM CHORD.
- C** THE PART 4 STRAP MUST HAVE ONE REPAIR FASTENER MORE THAN THE PART 2 ANGLE AT EACH END.
- D** BEND THE REPAIR ANGLE IN THE ANNEALED CONDITION, THEN HEAT TREAT AS SPECIFIED.

FASTENER SYMBOLS

- ✚ INITIAL FASTENER LOCATION. INSTALL A BACB30MY6K(X)X HEX DRIVE BOLT AND A BACC30M6 COLLAR. AS AN ALTERNATIVE, INSTALL A BACB30NY6K(Y)Y HEX DRIVE BOLT WITH A BACC30R6 COLLAR.
- ⊕ REPAIR FASTENER LOCATION. INSTALL A BACB30MY6K HEX DRIVE BOLT AND A BACC30M6 COLLAR.
- ⊕ REPAIR FASTENER LOCATION. INSTALL A BACB30NW6K HEX DRIVE BOLT AND A BACC30M6 COLLAR.
- ⊕ FLOOR PANEL FASTENER LOCATION. INSTALL A BACN10YD6G CLIP-ON NUT OR BACN10JR3CFD NUTPLATE AND THE SAME TYPE AND SIZE FLOOR PANEL FASTENER AS THE ONE THAT WAS REMOVED.

**Repair to One Flange of the Floor Beam Upper or Lower Chord
Figure 201 (Sheet 1 of 4)**



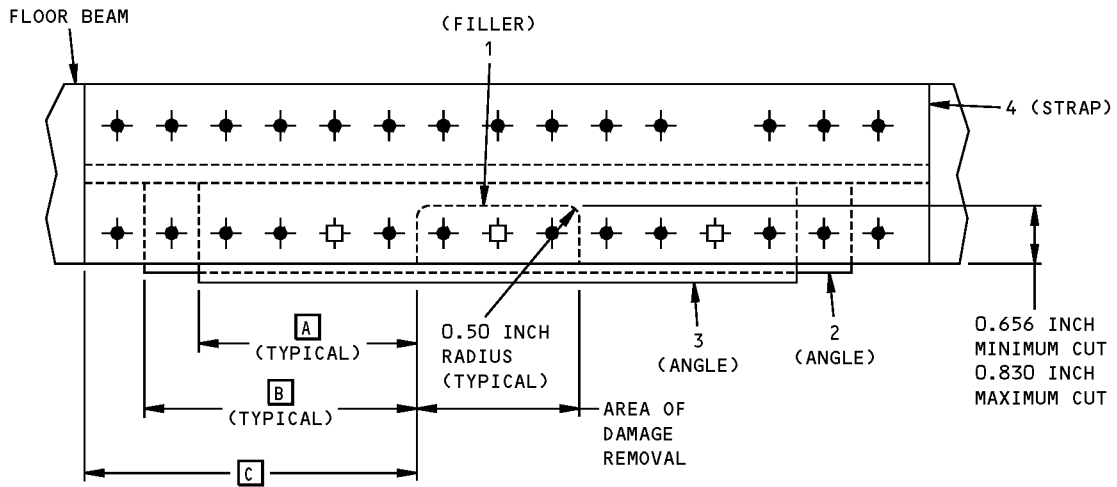
757-200
STRUCTURAL REPAIR MANUAL

REPAIR MATERIAL			
PART	QTY	MATERIAL	
1	FILLER	1	0.125 7075-T6
2	ANGLE	1	0.071 CLAD 7075-0 <input type="checkbox"/> D HT TR TO T6
3	ANGLE	1	0.071 CLAD 7075-0 <input type="checkbox"/> D HT TR TO T6
4	STRAP	1	0.050 CLAD 7075-T6
5	SHIM	2	0.071 CLAD 7075-T6 USE IF THERE IS INTERFERENCE WITH THE REPAIR PARTS AND A STIFFENER

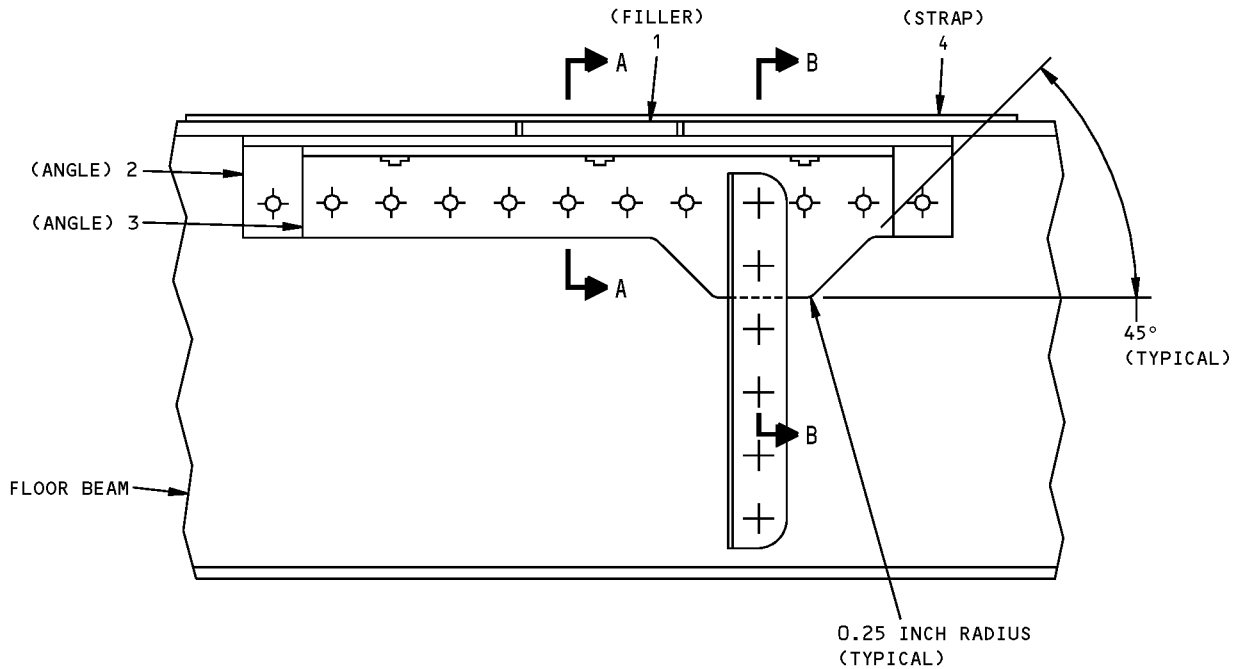
TABLE I

Repair to One Flange of the Floor Beam Upper or Lower Chord
Figure 201 (Sheet 2 of 4)

**757-200
STRUCTURAL REPAIR MANUAL**



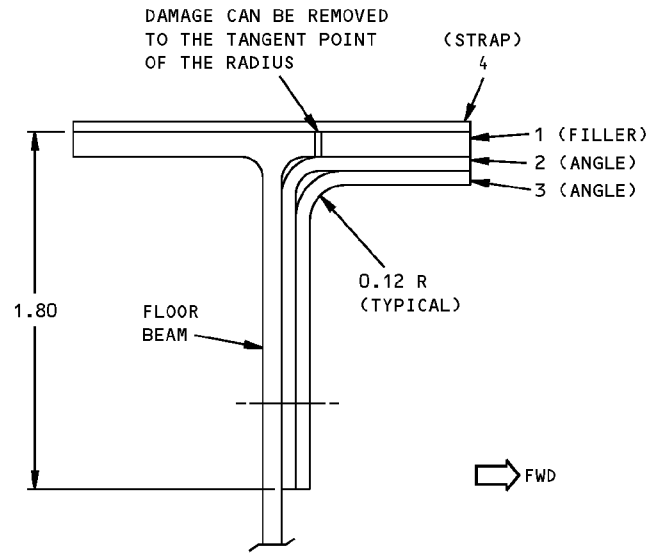
TOP VIEW
FLOOR BEAM



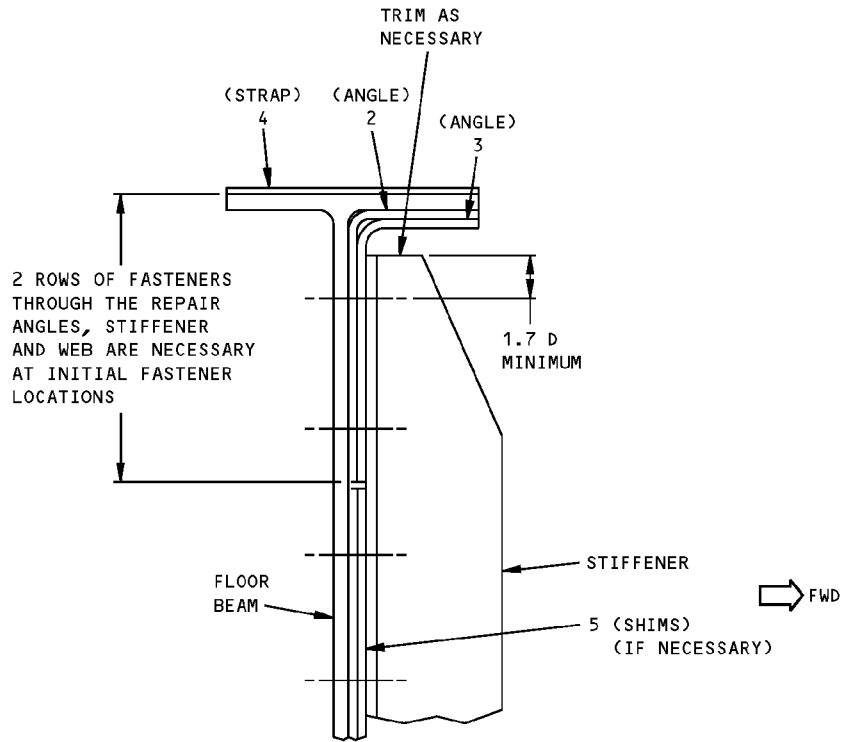
VIEW LOOKING AFT
FLOOR BEAM
DETAIL I

**Repair to One Flange of the Floor Beam Upper or Lower Chord
Figure 201 (Sheet 3 of 4)**

**757-200
STRUCTURAL REPAIR MANUAL**



SECTION A-A



SECTION B-B

**Repair to One Flange of the Floor Beam Upper or Lower Chord
Figure 201 (Sheet 4 of 4)**

STRUCTURAL REPAIR MANUAL

ALLOWABLE DAMAGE 1 - SEAT TRACKS

DESCRIPTION		CRACKS	NICKS, GOUGES, SCRATCHES, AND CORROSION	DENTS	HOLES AND PUNCTURES
SEAT TRACKS	CROWN	NOT PERMITTED	[C] [I]	NOT PERMITTED	NOT PERMITTED
	WEB		[D]	[F]	[G]
	FLANGE	[H]	[E]	NOT PERMITTED	[G]

NOTES

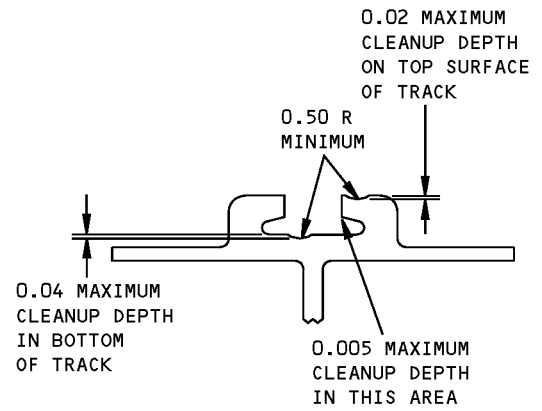
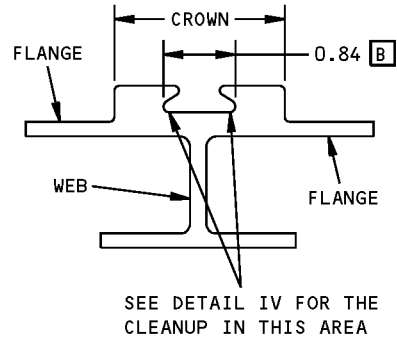
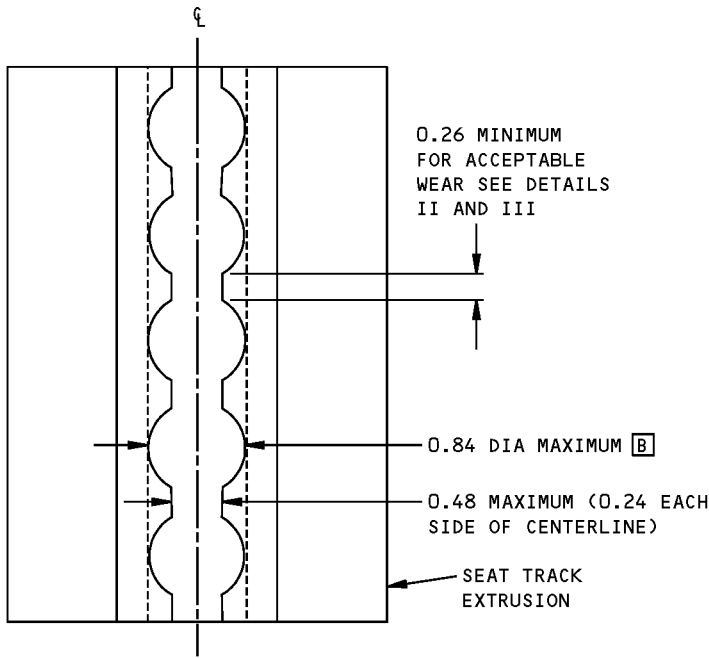
- THE INFORMATION CONTAINED HEREIN APPLIES TO EXTRUDED ALUMINIUM SEAT TRACKS ONLY.
- THIS ALLOWABLE DAMAGE DATA IS NOT APPLICABLE TO R/L BL 58.22 SEAT TRACKS FOR 757-SF AIRPLANES.
- THIS ALLOWABLE DAMAGE IS A CATEGORY A REPAIR FOR 757-SF AIRPLANES. THE INSPECTIONS GIVEN IN THE MAINTENANCE PLANNING DATA (MPD) AND ASSOCIATED SUPPLEMENT ARE SUFFICIENT TO MAINTAIN THE DAMAGE TOLERANCE OF THE INITIAL STRUCTURE WITH THIS ALLOWABLE DAMAGE. REFER TO SRM 51-00-06 FOR REPAIR CATEGORIES AND DEFINITIONS.
- ALL DIMENSIONS ARE IN INCHES
- REMOVE CORROSION AS GIVEN IN SRM 51-10-02. APPLY A CHEMICAL CONVERSION COATING TO THE REWORKED ALUMINUM AREAS. REFER TO SRM 51-20-01. FOR CUM LINE NUMBERS 1 THRU 477:
 - APPLY ONE LAYER OF BMS 10-11, TYPE I PRIMER
 - APPLY ONE LAYER OF BMS 10-86, TYPE I OR TYPE II WHITE URETHANE COATING.
- FOR CUM LINE NUMBERS 478 AND ON:
 - APPLY ONE LAYER OF ALUMINIZED EPOXY PRIMER. REFER TO SOPM 20-41-04.

- [A] THE AREA REMOVED FOR CLEANUP MUST NOT REDUCE THE FLANGE CROSS-SECTIONAL AREA BY MORE THAN 5 PERCENT.
- [B] DIMENSION FOR STUD HOLE ONLY. DOES NOT APPLY TO "LIP" REGION.

- [C] REMOVE DAMAGE AS SHOWN IN DETAILS I THRU IV.
- [D] BEFORE THE BLENDOUT OF THE DAMAGE IS DONE, DETERMINE THE DEPTH AND DO ONE OF THE STEPS THAT FOLLOW:
 - REMOVE THE DAMAGE AS SHOWN IN DETAILS V AND VI OR
 - TREAT AS A HOLE AND DRILL OUT THE DAMAGE.
- [E] BEFORE THE BLENDOUT OF THE DAMAGE IS DONE, DETERMINE THE DEPTH AND DO ONE OF THE STEPS THAT FOLLOW:
 - REMOVE THE DAMAGE AS SHOWN IN DETAILS VII AND VIII OR
 - TREAT AS A HOLE AND DRILL OUT THE DAMAGE.
- [F] DENTS ARE PERMITTED AS SHOWN IN DETAIL IX.
- [G] CLEAN OUT HOLE UP TO 0.25 MAX DIA AND NOT CLOSER THAN 0.20 TO ANY RADIUS AND 1.0 INCH TO FASTENER HOLES, PART EDGE, OR OTHER DAMAGE, AS SHOWN IN DETAIL VI. FILL THE HOLE WITH A 2117-T3 OR T4 ALUMINUM RIVET INSTALLED WET WITH BMS 5-95 SEALANT. ALL OTHER HOLES MUST BE REPAIRED.
- [H] CRACKS ARE NOT ALLOWED, EXCEPT FOR EDGE CRACKS WHICH MUST BE REMOVED AS SHOWN IN DETAIL X.
- [I] IF NO EQUIPMENT IS INSTALLED CLOSER THAN 3 INCHES, BOTH LIPS CAN BE TRIMMED OFF AS SHOWN IN DETAIL XI.

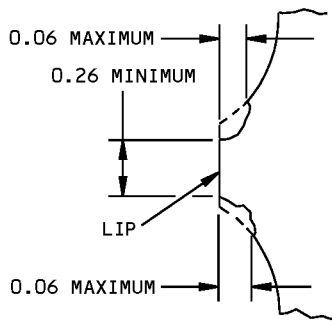
**Seat Tracks Allowable Damage
Figure 101 (Sheet 1 of 6)**

**757-200
STRUCTURAL REPAIR MANUAL**

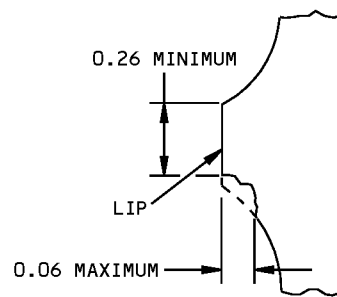


REMOVAL OF DAMAGE AT THE CROWN AREA
(DIMENSIONS SHOWN ARE THE SAME FOR SEAT TRACKS OVER THE WING)

DETAIL I



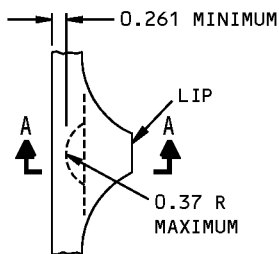
DETAIL II



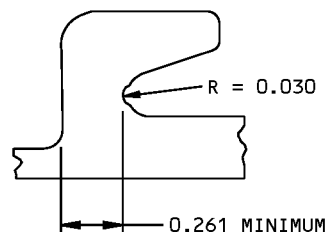
DETAIL III

**Seat Tracks Allowable Damage
Figure 101 (Sheet 2 of 6)**

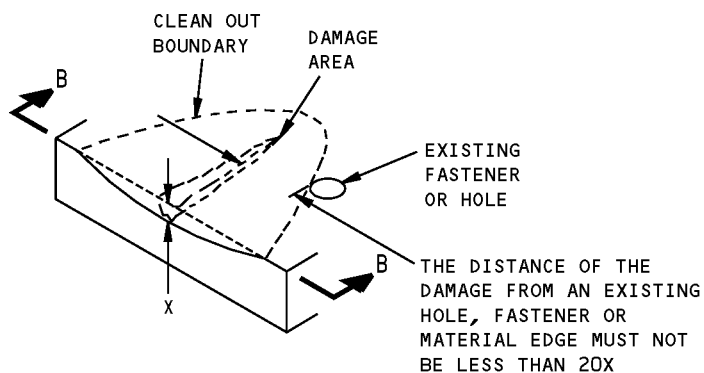
STRUCTURAL REPAIR MANUAL



DETAIL IV

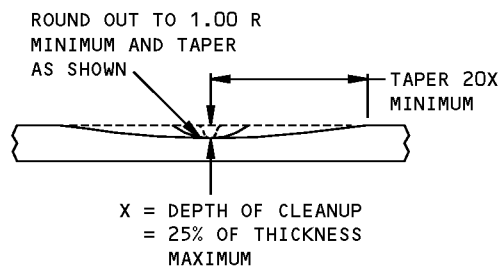


SECTION A-A

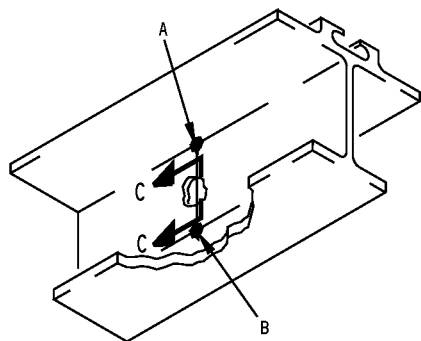


REMOVAL OF NICK, GOUGE, CORROSION, AND SCRATCH DAMAGE ON A SURFACE

DETAIL V

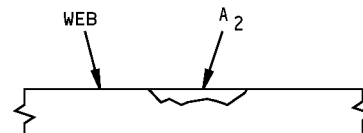


SECTION B-B



LOSS IN CROSS-SECTIONAL AREA ALONG ANY LINE A-B DUE TO REMOVAL OF NICKS, SCRATCHES, GOUGES OR CORROSION PER DETAIL V AND DUE TO PUNCTURE CLEANUP PER NOTE [6] MUST NOT EXCEED 10% OF ORIGINAL WEB NET CROSS-SECTIONAL AREA (SEE SECTION C-C)

DETAIL VI



A_1 = NET WEB AREA = TOTAL AREA - ORIGINAL EXISTING HOLES AS MANUFACTURED

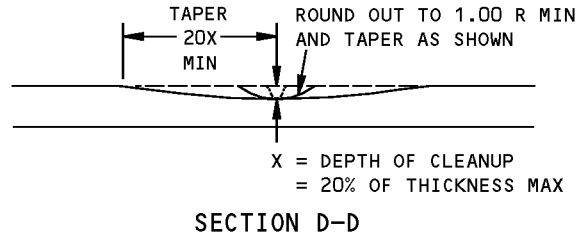
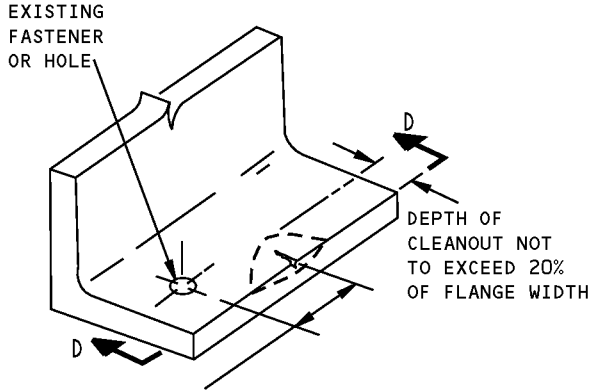
A_2 = WEB AREA REMOVED FOR NICKS, SCRATCHES, GOUGES, PUNCTURES OR CORROSION AFTER CLEANUP

$$\left(\frac{A_2}{A_1}\right) = 10\% \text{ MAXIMUM}$$

SECTION C-C (ROTATED)

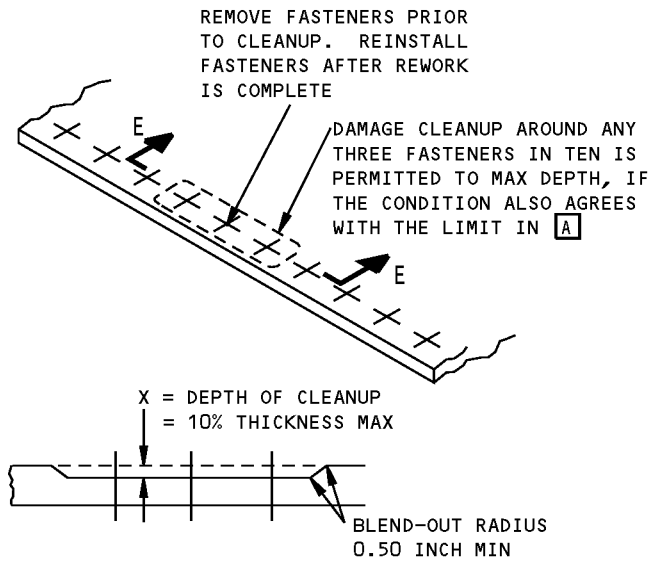
Seat Tracks Allowable Damage
Figure 101 (Sheet 3 of 6)

STRUCTURAL REPAIR MANUAL



THE DISTANCE OF THE DAMAGE FROM AN EXISTING HOLE, FASTENER OR MATERIAL EDGE MUST NOT BE LESS THAN 20X

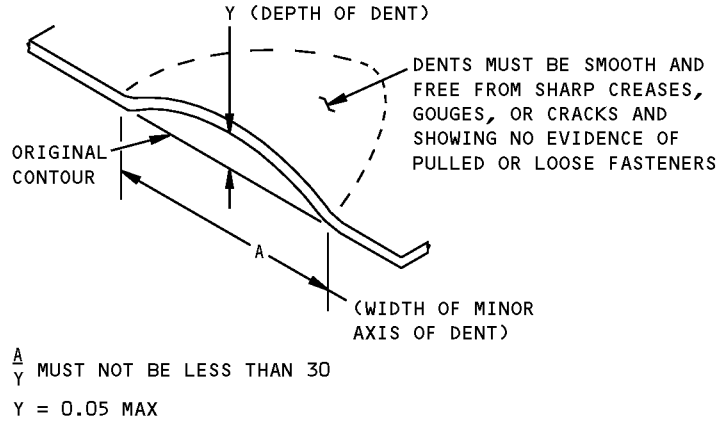
**REMOVAL OF NICK, GOUGE, CORROSION, AND SCRATCH DAMAGE ON A SURFACE
DETAIL VII**



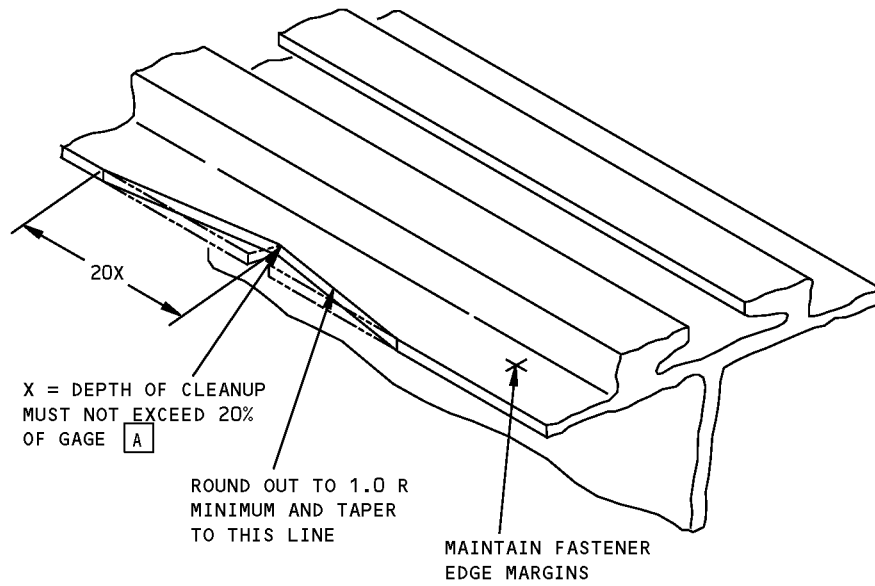
**SECTION E-E
DAMAGE CLEANUP
DETAIL VIII**

**Seat Tracks Allowable Damage
Figure 101 (Sheet 4 of 6)**

**757-200
STRUCTURAL REPAIR MANUAL**



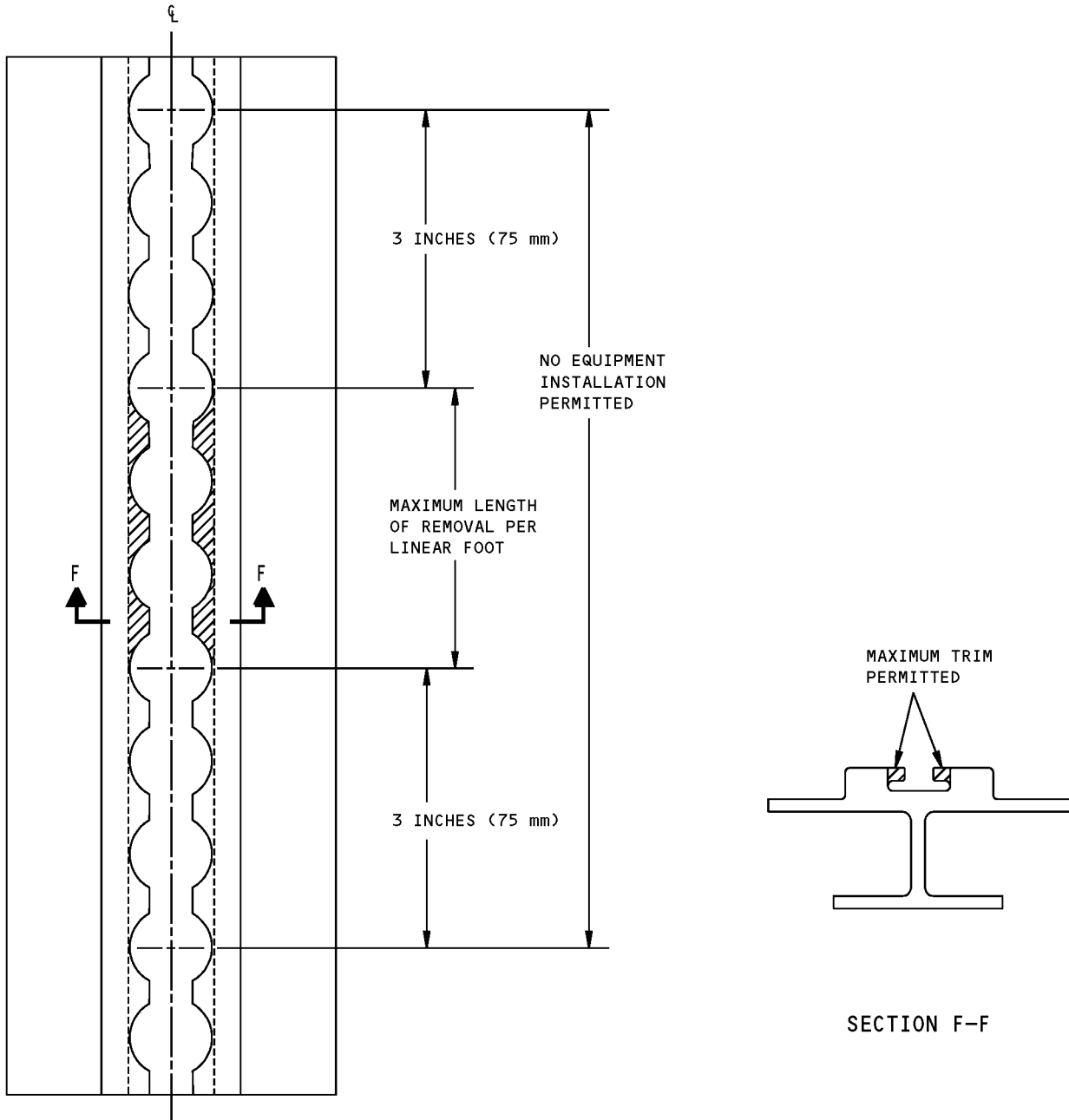
**ALLOWABLE DAMAGE FOR DENT
DETAIL IX**



DETAIL X

**Seat Tracks Allowable Damage
Figure 101 (Sheet 5 of 6)**

**757-200
STRUCTURAL REPAIR MANUAL**



REMOVAL OF DAMAGE AT THE CROWN LIP AREA
WHERE NO EQUIPMENT IS INSTALLED

DETAIL XI

**Seat Tracks Allowable Damage
Figure 101 (Sheet 6 of 6)**

STRUCTURAL REPAIR MANUAL

REPAIR 1 - SEAT TRACK REPAIR (BAC1520-792) - OPTION 1

REPAIR INSTRUCTIONS

1. Remove floor panels as required.
2. Remove damaged seat track section.
 - A. Make cut at seat track hole located 9.45 inches (240 mm) or 10.45 inches (265 mm) from a floor beam centerline.

NOTE: Cut must also be 0.55 inch (14 mm) minimum from original floor panel fastener locations.
 - B. Cut track at center of seat track hole within +0.09 inch (+2.2 mm) and -0.04 inch (-1.0 mm).
3. Make the repair parts.

NOTE: Do not trim upper horizontal flanges of repair part 1 to match original seat track section between the two floor beams where the cut was made. It is also not necessary to trim upper horizontal flanges outside of cut area mentioned.
4. Assemble the repair parts and drill the fastener holes.
 - A. Drill the fastener holes that will attach the repair parts 2 and repair part 3 to the seat track sections per Detail II.
 - B. Backdrill through the existing floor-beam fastener holes that will attach repair part 1 to the floorbeam(s).
 - C. Drill the fastener holes that will attach the floor panels to repair part 1.
5. Remove the repair parts.
6. Break sharp edges of original and repair parts 0.015 to 0.030 inch (0.4 TO 0.8 mm)
7. Remove all nicks, scratches, burrs, sharp edges and corners from original and repair parts.
8. Apply a protective coating.
 - A. For the part 2 angle, the part 3 strap, and the cut edges of the initial seat track, do as follows:
 - (1) Apply a chemical conversion coating. Refer to SRM 51-20-01.

(2) For cum line numbers 2 thru 476:

- Apply one layer of BMS 10-11, Type I primer
- Apply one layer of BMS 10-11, Type II white enamel.

For cum line numbers 478 and on, apply one layer of aluminized epoxy primer. Refer to SOPM 20-41-04.

- B. For repair part 1 see Detail I for the applicable protective coating.
9. Install repair parts.
 - A. Make fay surface seals with BMS 5-95 sealant.
 - B. Install fasteners wet with BMS 5-95 sealant.
10. Fill the gap between repair part 1 and the existing seat track with BMS 5-95 sealant.
11. Restore original finish per AMM 51-21
12. Reinstall floor panels.
 - A. Install floor panel fasteners with MIL-C-11796, Class 3 corrosion prevention compound. Apply one layer of BMS 10-11, Type I primer to the clip nuts. Torque the fasteners 20 to 25 pound-inches.

NOTES

- THIS IS A CATEGORY A REPAIR FOR 757-SF AIRPLANES. THE INSPECTIONS GIVEN IN THE MAINTENANCE PLANNING DATA (MPD) ARE SUFFICIENT TO MAINTAIN THE DAMAGE TOLERANCE OF THE INITIAL STRUCTURE WITH THIS REPAIR INSTALLED. REFER TO SRM 51-00-06 FOR REPAIR CATEGORIES AND DEFINITIONS.
- THIS REPAIR APPLIES TO SEAT TRACKS MADE FROM BAC1520-792 EXTRUSIONS.
- THIS REPAIR APPLIES TO SEAT TRACKS WHERE THE UPPER HORIZONTAL FLANGES OF THE UNDAMAGED SEAT TRACK SECTION HAVE NOT BEEN WHOLLY OR PARTIALLY MACHINED BETWEEN THE TWO FLOOR BEAMS WHERE THE SPLICE WILL BE MADE.
- TO REPAIR SEAT TRACKS WHICH HAVE UPPER HORIZONTAL FLANGES MACHINED OUT, REFER TO REPAIR 4.
- THE REPAIR IN REPAIR 4 IS AN ALTERNATIVE TO THIS REPAIR.
- THE REPAIR SPLICE MAY BE MADE BETWEEN ANY PAIR OF ADJACENT FLOOR BEAMS.

Seat Track Repair (BAC1520-792) - Option 1
Figure 201 (Sheet 1 of 5)

STRUCTURAL REPAIR MANUAL

NOTES (CONT)

- WHEN USING THIS REPAIR REFER TO:
 - AMM 51-21 FOR INTERIOR AND EXTERIOR FINISHES
 - AMM 51-21 FOR CORROSION PROTECTIVE FINISHES
 - AMM 51-31 FOR SEALS AND SEALING
 - SRM 51-10-02 FOR INSPECTION AND REMOVAL OF DAMAGE
 - SRM 51-20-01 FOR PROTECTIVE TREATMENT OF METALS
 - SRM 51-20-05 FOR SEALING OF REPAIRS
 - SRM 51-40 FOR FASTENER CODE, REMOVAL, INSTALLATION, HOLE SIZES AND EDGE MARGINS

A CHAMFER END OF EXISTING SEAT TRACK AND REPAIR PART 1, 0.06 INCH X 45° (1.5 mm X 45°).

B QUANTITY INDICATED IS QUANTITY REQUIRED AT EACH CUT LOCATION.

C TRIM WEB AND LOWER HORIZONTAL FLANGES OF REPAIR PART 1 SIMILAR TO ORIGINAL SEAT TRACK SECTION. DO NOT TRIM UPPER HORIZONTAL FLANGES OF REPAIR PART 1 TO MATCH ORIGINAL SEAT TRACK SECTION BETWEEN THE TWO FLOOR BEAMS WHERE THE CUT WAS MADE. IT IS ALSO NOT NECESSARY TO TRIM UPPER HORIZONTAL FLANGES OUTSIDE OF CUT AREA MENTIONED.

D A MINIMUM OF 7 REPAIR FASTENERS MUST BE USED ON EACH SIDE OF THE SPLICE THROUGH THE HORIZONTAL FLANGE OF REPAIR PARTS 2. ADJUST FASTENER SPACING TO PRECLUDE FLOOR PANEL FASTENER INTERFERENCE AND MAINTAIN EQUAL SPACING.

E A MINIMUM OF 9 REPAIR FASTENERS MUST BE USED ON EACH SIDE OF THE SPLICE THROUGH THE VERTICAL FLANGE OF REPAIR PARTS 2. USE 0.75 INCH (19 mm) FASTENER SPACING.

F A MINIMUM OF 14 REPAIR FASTENERS MUST BE USED ON EACH SIDE OF THE SPLICE THROUGH REPAIR PART 3. USE 0.66 INCH (17 mm) FASTENER SPACING.

G REFER TO REPAIR 2 FOR HOLE PATTERN FOR REPAIR PART 1.

H CUT MUST BE 0.55 INCH (14.0 mm) MINIMUM FROM ORIGINAL FLOOR PANEL FASTENER LOCATIONS.

I TRIM REPAIR PART 3 TO MATCH LOWER HORIZONTAL FLANGES OF EXISTING SEAT TRACK AND REPAIR PART 1.

J FILL THE GAP BETWEEN REPAIR PART 1 AND THE EXISTING SEAT TRACK WITH BMS 5-95 SEALANT.

K APPLY A CHEMICAL CONVERSION COATING TO THE REWORKED ALUMINUM AREAS. REFER TO SRM 51-20-01.

FOR CUM LINE NUMBERS 2 THRU 476, APPLY ONE LAYER OF BMS 10-11, TYPE I PRIMER.

FOR CUM LINE NUMBERS 478 AND ON, APPLY ONE LAYER OF ALUMINIZED EPOXY PRIMER. REFER TO SOPM 20-41-04

L APPLY A CHEMICAL CONVERSION COATING TO THE REWORKED ALUMINUM AREAS. REFER TO SRM 51-20-01.

FOR CUM LINE NUMBERS 2 THRU 476:

- APPLY ONE LAYER OF BMS 10-11, TYPE I PRIMER

- APPLY ONE LAYER OF BMS 10-86, TYPE I OR TYPE II WHITE URETHANE COATING.

FOR CUM LINE NUMBERS 478 AND ON, APPLY ONE LAYER OF ALUMINIZED EPOXY PRIMER. REFER TO SOPM 20-41-04.

M APPLY A CHEMICAL CONVERSION COATING TO THE REWORKED ALUMINUM AREAS. REFER TO SRM 51-20-01.

FOR CUM LINE NUMBERS 2 THRU 476:

- APPLY ONE LAYER OF BMS 10-11, TYPE I PRIMER

- APPLY ONE LAYER OF BMS 10-11, TYPE II WHITE ENAMEL.

FOR CUM LINE NUMBERS 478 AND ON, APPLY ONE LAYER OF ALUMINIZED EPOXY PRIMER. REFER TO SOPM 20-41-04.

N FAY SURFACE SEAL WITH BMS 5-95 SEALANT.

FASTENER SYMBOLS

⊕ ORIGINAL FASTENER LOCATION. USE SAME TYPE AND SIZE FASTENER AS ORIGINAL FASTENER.

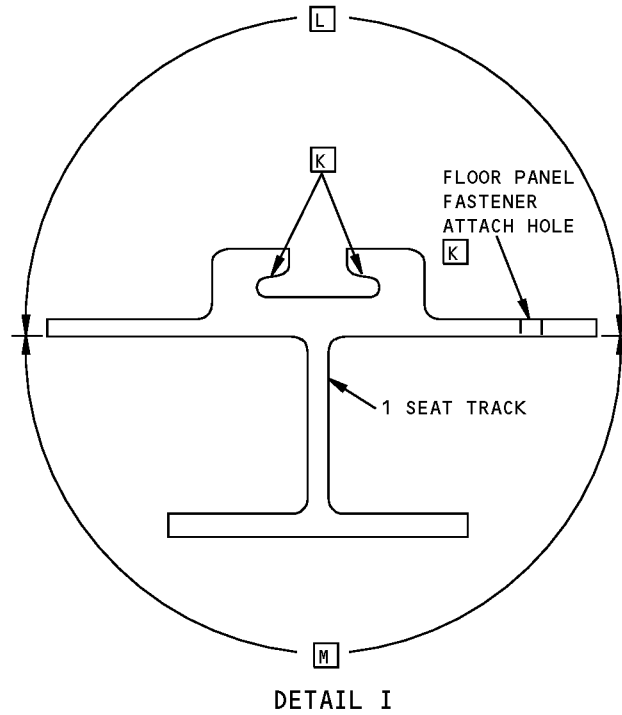
⊕ REPAIR FASTENER LOCATION. INSTALL BACB30VU8K HI-LOK WITH A BACC30X()S COLLAR.

⊕ REPAIR FASTENER LOCATION. INSTALL BACB30MY6K HI-LOK WITH A BACC30M COLLAR.

**Seat Track Repair (BAC1520-792) - Option 1
Figure 201 (Sheet 2 of 5)**

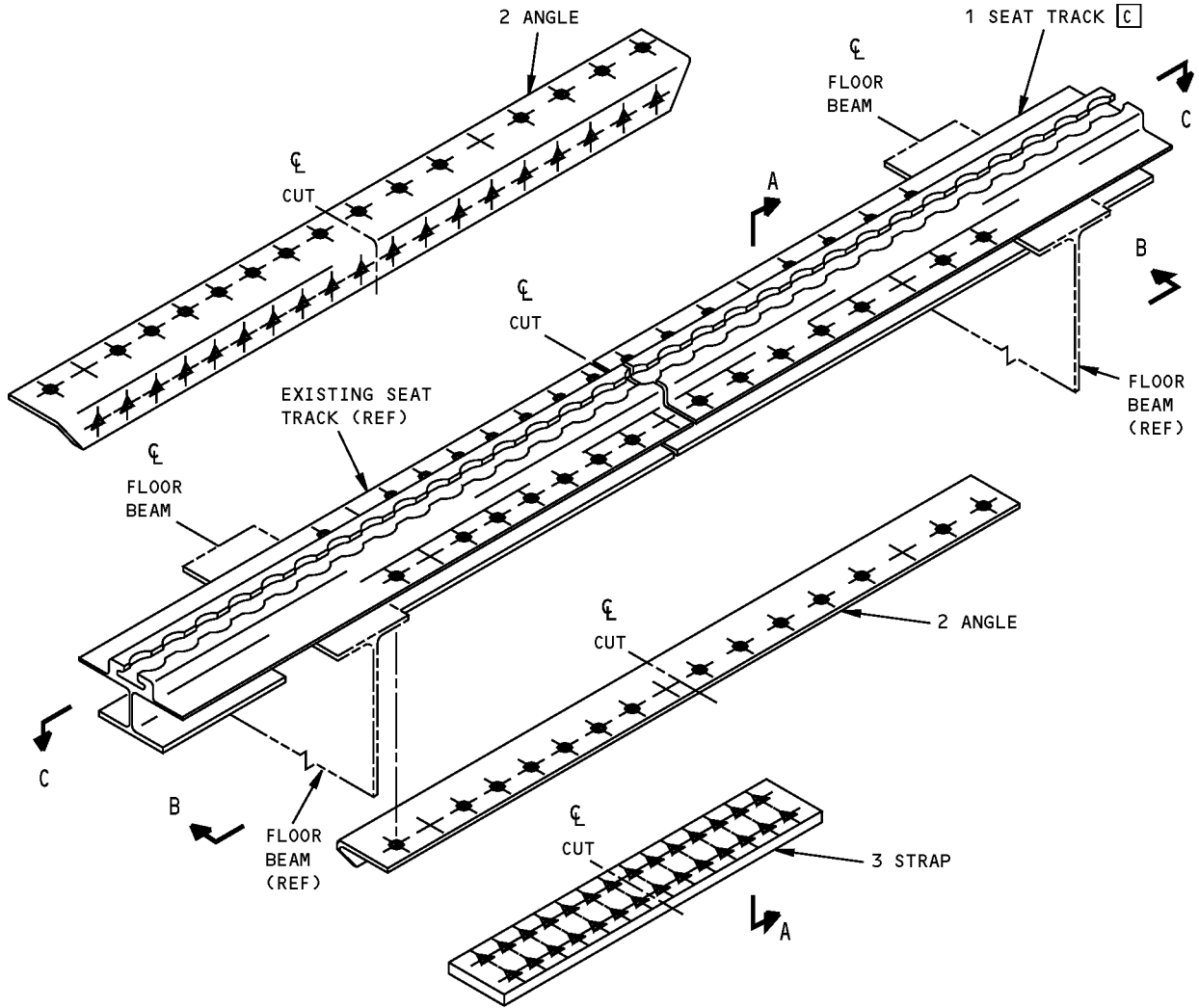
**757-200
STRUCTURAL REPAIR MANUAL**

REPAIR MATERIAL			
PART		QTY	MATERIAL
1	SEAT TRACK	1	BAC1520-792 7178-T6511 AS AN ALTERNATIVE USE 7150-T77511
2	ANGLE	2 B	BAC1503-100122 7075-T6
3	STRAP I	1 B	0.30 7075-T651

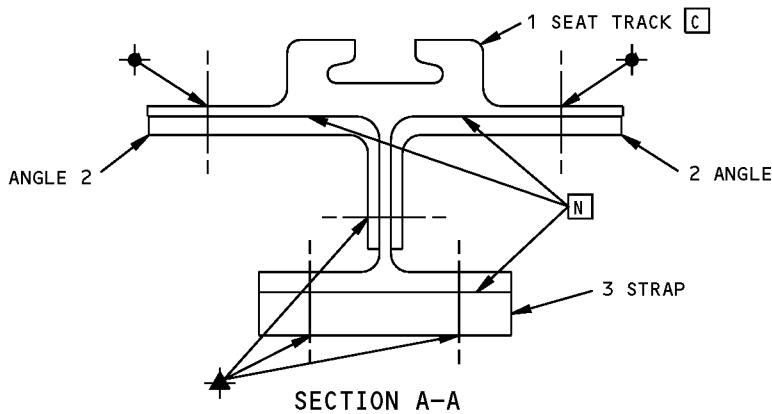


**Seat Track Repair (BAC1520-792) - Option 1
Figure 201 (Sheet 3 of 5)**

**757-200
STRUCTURAL REPAIR MANUAL**

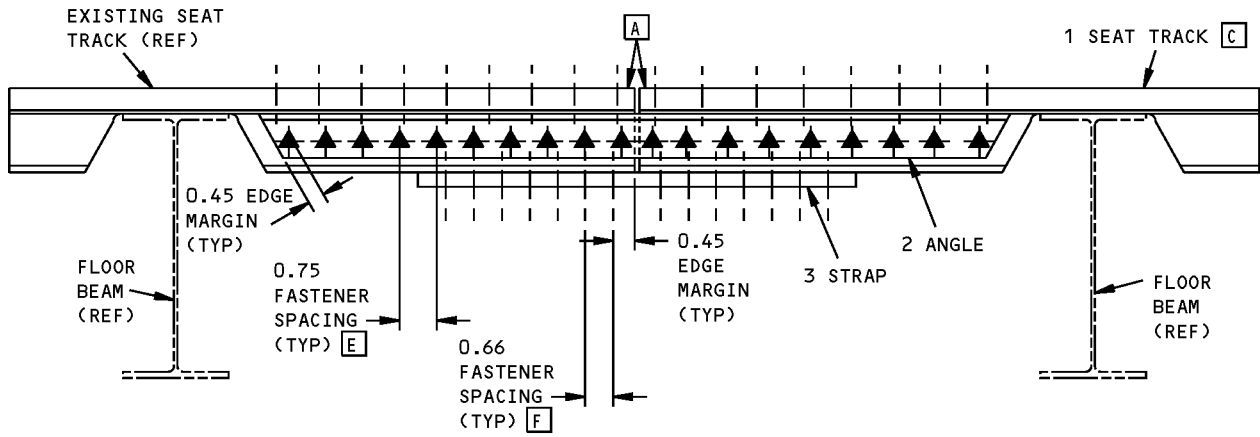


DETAIL II

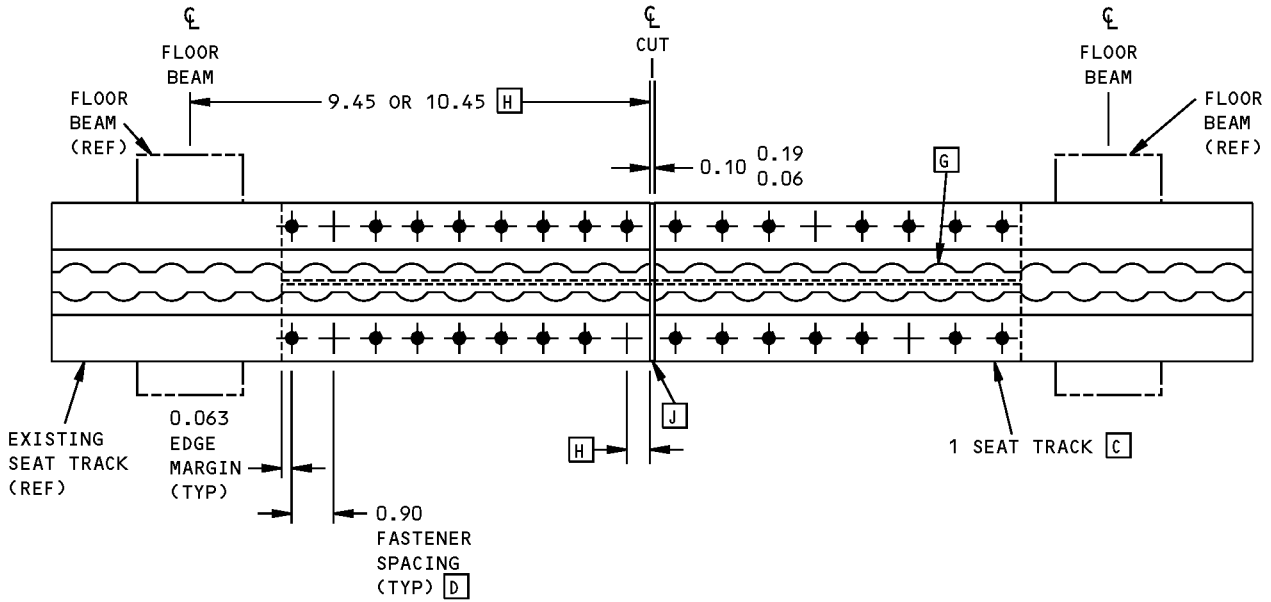


**Seat Track Repair (BAC1520-792) - Option 1
Figure 201 (Sheet 4 of 5)**

**757-200
STRUCTURAL REPAIR MANUAL**



SECTION B-B

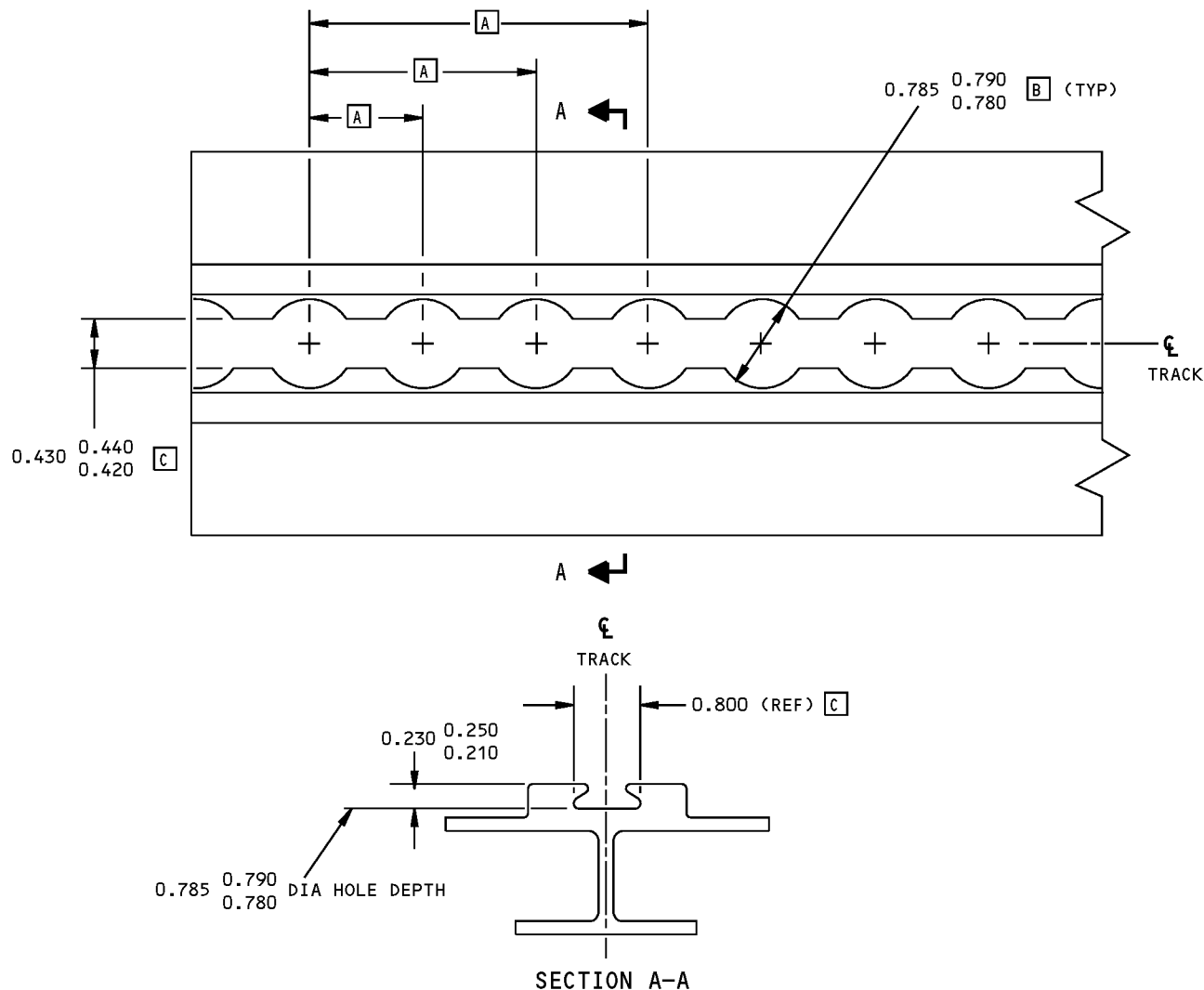


SECTION C-C

**Seat Track Repair (BAC1520-792) - Option 1
Figure 201 (Sheet 5 of 5)**

**757-200
STRUCTURAL REPAIR MANUAL**

REPAIR 2 - HOLE PATTERN FOR SEAT TRACK REPAIRS



NOTES

- THIS IS A CATEGORY A REPAIR FOR 757-SF AIRPLANES. THE INSPECTIONS GIVEN IN THE MAINTENANCE PLANNING DATA (MPD) ARE SUFFICIENT TO MAINTAIN THE DAMAGE TOLERANCE OF THE INITIAL STRUCTURE WITH THIS REPAIR INSTALLED. REFER TO SRM 51-00-06 FOR REPAIR CATEGORIES AND DEFINITIONS.
- MACHINE FINISH TO 125 MICROINCHES AA

- A** LOCATION OF STUD HOLES TO BE 1.000 INCH TIMES NUMBER OF HOLES ± 0.005 BETWEEN ANY TWO HOLES IN ANY 20-INCH INCREMENT AND ± 0.015 BETWEEN ANY TWO HOLES IN ANY 100-INCH INCREMENT AT 70°F (21°C)
- B** 0.785 DIA HOLE TO BE LOCATED TO CENTERLINE OF 0.430 SLOT WITHIN ± 0.005
- C** 0.430 THROAT DIMENSION CUT SHALL BE INDEXED TO CENTERLINE OF 0.800 DIMENSION ± 0.010

SYMBOLS

+ STUD HOLE LOCATION

**Hole Pattern for Seat Track Repairs
Figure 201**

STRUCTURAL REPAIR MANUAL

REPAIR 3 - SEAT TRACK REPAIR (BAC1520-792) - OPTION 2

REPAIR INSTRUCTIONS

1. Remove the floor panels as necessary.
2. Remove the damaged seat track section.
Refer to Detail II.
 - A. Make a cut at the center of the seat track hole which is 9.45 (240 mm) or 10.45 inches (265 mm) from a floor beam centerline. Refer to Section A-A.
NOTE: The cut must also be a minimum of 0.55 inches (14 mm) from initial floor panel fastener locations. Refer to Section A-A.
3. Make the repair parts. Refer to Detail II.
 - A. For repair part 1:
 - (1) Cut the web and lower horizontal flanges to the same contour as the initial seat track for sections between floor beams where no splices will be made.
 - (2) Cut off the web and the lower horizontal flanges of the seat track sections between the floor beams where the splice will be made. See Detail I.
 - (3) Refer to repair 2 and make the seat track hole pattern.
 - B. For repair part 2, refer to Sections A-A and B-B and cut to the contour shown.
4. Cut off the web and the lower horizontal flanges of the initial seat track section between the floor beams where the splice will be made. Refer to Detail I.
5. Assemble the repair parts and drill the fastener holes.
 - A. Drill the fastener holes that will attach repair part 2 to the seat track sections and countersink as required.
 - B. Backdrill through the existing floor beam fastener holes that will attach repair part 1 to the floor beam(s).
 - C. Drill the fastener holes that will attach the floor panels to repair part 1.
6. Remove the repair parts.
7. Remove all nicks, scratches, gouges, burrs, and sharp edges from the initial and repair parts.
8. Apply a protective coating.
 - A. Clean and chromic acid anodize repair part 1. Refer to 20-43-03 (Type I) of the Standard Overhaul Practices Manual.
 - B. Clean and apply Alodine to:
 - (1) Repair part 2.
 - (2) The cut edges of the seat track.
Refer to 51-20-01.
9. Apply a finish.
 - A. Apply one coat of aluminized epoxy primer 463-6-4 (Catalyst X-306; Thinner TL-52; vendor number V98052) to:
 - (1) Repair part 1.
 - (2) The cut edges of the seat track.
 - (3) All of the holes in the initial seat track and repair part 1 where floor panels (which were removed) will be attached.
 - (4) Repair part 2.
Refer to 20-41-04 of the Standard Overhaul Practices Manual.
10. Install repair parts 1 and 2.
 - A. Apply BMS 5-95 sealant to the faying surfaces. Refer to Details III and IV.
 - B. Install the fasteners wet with BMS 5-95 sealant.
11. Fill the gap between repair part 1 and the initial seat track with BMS 5-95 sealant.

Seat Track Repair (BAC1520-792) - Option 2
Figure 201 (Sheet 1 of 6)

STRUCTURAL REPAIR MANUAL

REPAIR INSTRUCTIONS (CONT)

12. Make sure that no finish or protective coating has been visibly removed from the repair area after assembly of the repair parts. Refer to step 8 to apply the protective coating and step 9 to apply the finish, as necessary.
13. Install the floor panels. The following steps apply to all of the holes where floor panels will be attached.
 - A. In wet areas only (under lavatories, galleys and around doors), apply MIL-C-11796 Class 3 in all of the holes prior to installing clip-on nuts. In dry areas, this step is not required.
 - B. Install a BAC10FX() clip-on nut primed with BMS 10-11, Type I primer at each hole.
 - C. Install the floor panel fasteners and torque to 20-25 in-lbs.

NOTES

- THIS IS A CATEGORY A REPAIR FOR 757-SF AIRPLANES. THE INSPECTIONS GIVEN IN THE MAINTENANCE PLANNING DATA (MPD) ARE SUFFICIENT TO MAINTAIN THE DAMAGE TOLERANCE OF THE INITIAL STRUCTURE WITH THIS REPAIR INSTALLED. REFER TO SRM 51-00-06 FOR REPAIR CATEGORIES AND DEFINITIONS.
- THIS REPAIR APPLIES TO SEAT TRACKS MADE FROM BAC1520-792 EXTRUSIONS.
- THIS REPAIR IS AN ALTERNATIVE TO THE REPAIR IN REPAIR 1.

- WHEN YOU USE THIS REPAIR REFER TO:
 - AMM 51-21 FOR INTERIOR AND EXTERIOR FINISHES
 - AMM 51-21 FOR CORROSION PROTECTIVE FINISHES
 - AMM 51-31 FOR SEALS AND SEALING.
 - SOPM 20-41-04 FOR APPLYING ALUMINIZED EPOXY PRIMER
 - SOPM 20-43-01 FOR CHROMIC ACID ANODIZING
 - SRM 51-10-02 FOR INSPECTION AND REMOVAL OF DAMAGE
 - SRM 51-20-01 FOR PROTECTIVE TREATMENT OF METAL
 - SRM 51-20-05 FOR SEALING OF REPAIRS
 - SRM 51-40 FOR FASTENER CODE, REMOVAL, INSTALLATION, HOLE SIZES AND EDGE MARGINS

- A** REFER TO REPAIR 2 FOR THE SEAT TRACK HOLE PATTERN ON REPAIR PART 1.
- B** ONE CHANNEL IS REQUIRED AT EACH SPLICE LOCATION.

Seat Track Repair (BAC1520-792) - Option 2
Figure 201 (Sheet 2 of 6)

**757-200
STRUCTURAL REPAIR MANUAL**

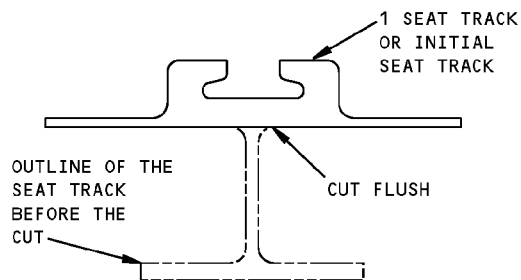
NOTES (CONT)

- C** FILL THE GAP BETWEEN REPAIR PART 1 AND THE INITIAL SEAT TRACK WITH BMS 5-95 SEALANT.
- D** CHAMFER THE CUT ENDS OF THE INITIAL SEAT TRACK AND REPAIR PART 1 0.06 X 45°.
- E** THE CUT MUST BE A MINIMUM OF 0.55 INCHES FROM INITIAL FLOOR PANEL FASTENER LOCATIONS.
- F** APPLY BMS 5-95 SEALANT TO FAYING SURFACES.
- G** THE MAXIMUM GAP PERMITTED IS 0.01 INCH. THE MAXIMUM SHIM THICKNESS PERMITTED IS 0.06 INCH.
- H** THE WEB AND LOWER HORIZONTAL FLANGES ARE TO HAVE THE SAME CONTOUR AS THE INITIAL SEAT TRACK SECTION BETWEEN FLOOR BEAMS WHERE NO SPLICES ARE MADE.

FASTENER SYMBOLS

- + INITIAL FLOOR PANEL FASTENER LOCATION. USE THE SAME TYPE AND THE SAME SIZE FASTENER AS THE INITIAL FASTENER.
- ✦ REPAIR FASTENER LOCATION. INSTALL A BACB30NY8K HI-LOK WITH A BACC30X8 COLLAR.
- ⊞ REPAIR FASTENER LOCATION. INSTALL A BACB30NY6K HI-LOK WITH A BACC30X6 COLLAR.

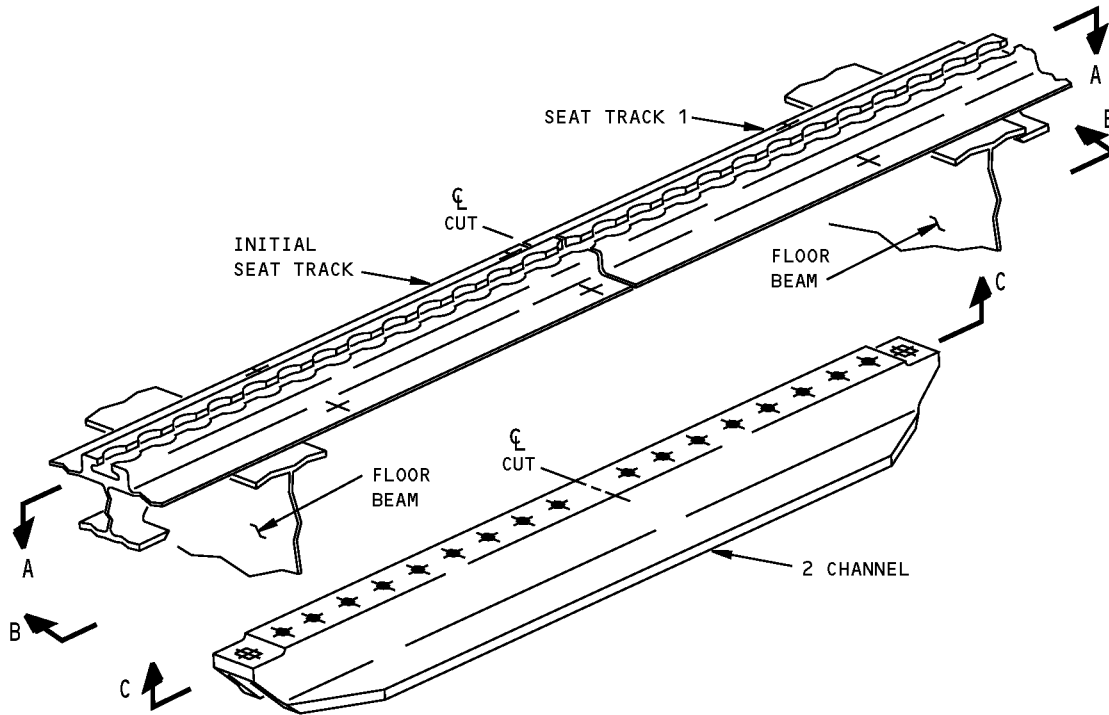
REPAIR MATERIAL			
PART		QTY	MATERIAL
1	SEAT TRACK	1 A	BAC1520-792 7178-T6 AS AN ALTERNATIVE USE 7150-T77511
2	CHANNEL	B	BAC1509-100449 7075-T6



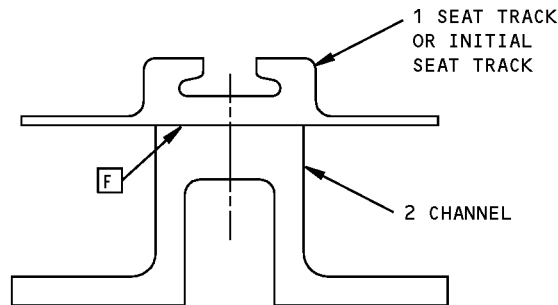
**REMOVAL OF THE WEB AND LOWER
HORIZONTAL FLANGES OF REPAIR
PART 1 AND THE INITIAL SEAT TRACK
DETAIL I**

**Seat Track Repair (BAC1520-792) - Option 2
Figure 201 (Sheet 3 of 6)**

**757-200
STRUCTURAL REPAIR MANUAL**



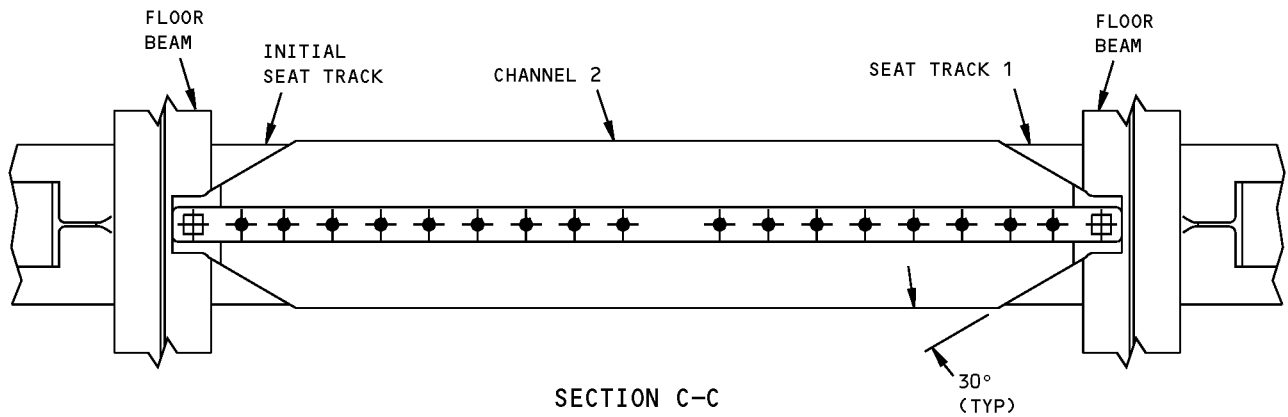
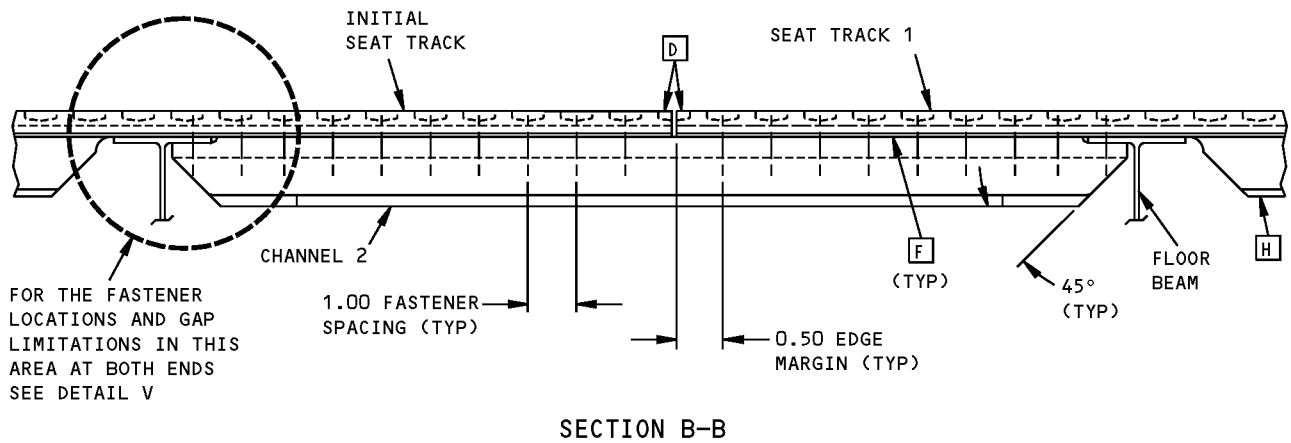
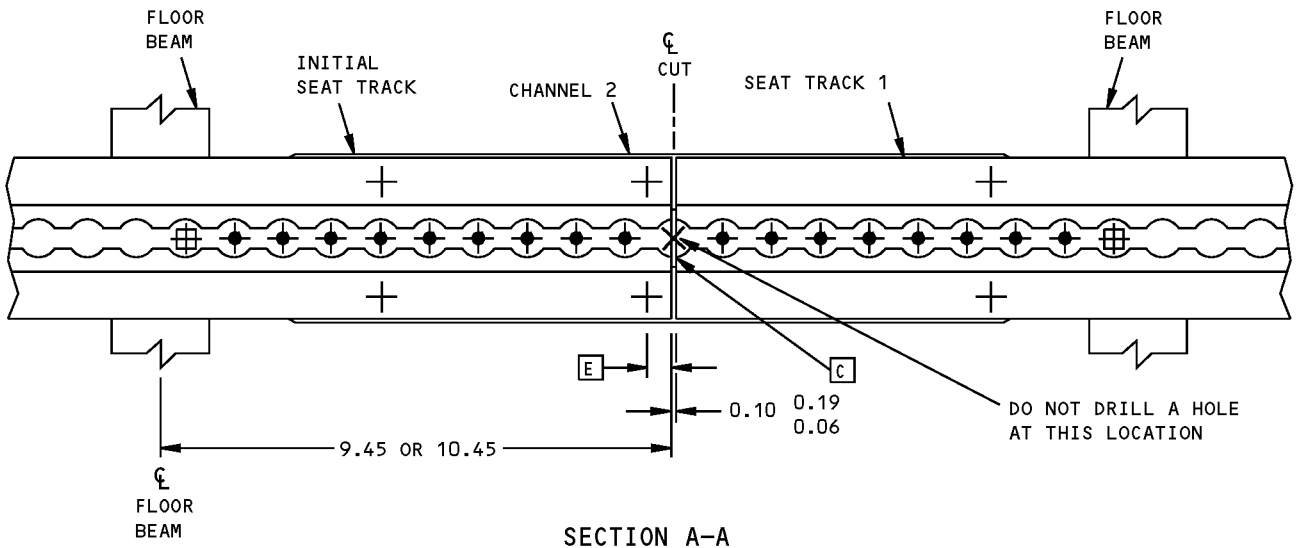
ALTERNATIVE BAC1520-792 SEAT TRACK REPAIR
(REPAIR PART 2 EXPLODED AWAY)
DETAIL II



TYPICAL SECTION CUT OF THE
SEAT TRACK SPLICE BETWEEN FLOOR BEAMS
DETAIL III

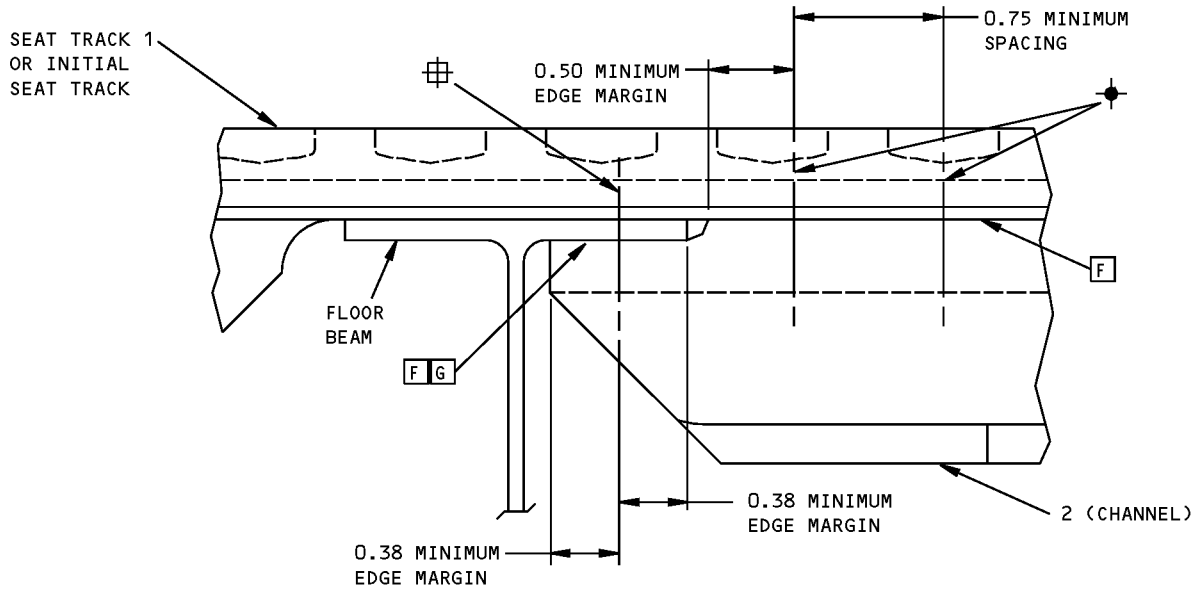
**Seat Track Repair (BAC1520-792) - Option 2
Figure 201 (Sheet 4 of 6)**

**757-200
STRUCTURAL REPAIR MANUAL**



**Seat Track Repair (BAC1520-792) - Option 2
Figure 201 (Sheet 5 of 6)**

**757-200
STRUCTURAL REPAIR MANUAL**



**FASTENER LOCATIONS AND GAP LIMITATIONS AT A FLOOR BEAM
DETAIL IV**

**Seat Track Repair (BAC1520-792) - Option 2
Figure 201 (Sheet 6 of 6)**

STRUCTURAL REPAIR MANUAL

REPAIR 4 - SEAT TRACK REPAIR (BAC1520-841)

REPAIR INSTRUCTIONS

1. Remove floor panels as required.
2. Remove damaged seat track section.
 - A. Cut the seat track between the attach bolts per Detail II.
3. Make the repair parts. See Detail I.
4. Assemble the repair parts and drill the fastener holes.
 - A. Drill and countersink the fastener holes in repair part 1 to match the original section that was removed.
5. Remove the repair parts.
6. Break sharp edges of original and repair parts 0.015 to 0.030 (0.4 TO 0.8 mm)
7. Remove all nicks, scratches, burrs, sharp edges and corners from original and repair parts.
8. Apply a protective coating.
 - A. For the part 2 plate, the part 3 plate and the cut edges of the initial seat track, do as follows:
 - (1) Apply a chemical conversion coating to the reworked aluminum areas. Refer to SRM 51-20-01.
 - (2) For cum line numbers 2 thru 476:
 - Apply one layer of BMS 10-11, Type I primer
 - Apply one layer of BMS 10-86, Type I or Type II white urethane coating.

For cum line numbers 478 and on, apply one layer of aluminized epoxy primer. Refer to 20-41-04 of the Standard Overhaul Practices Manual D6-51702.
 - B. For repair part 1, see Detail I for applicable protective coating.
9. Install repair part 1.
 - A. Make fay surface seals with BMS 5-95 sealant.
 - B. Install fasteners wet with BMS 5-95 sealant.
10. Fill the gap between repair part 1 and the existing seat track with BMS 5-95 sealant.

11. Install repair parts 2 and 3 to prevent installation of seats at track joint.
 - A. Make fay surface seals with BMS 5-95 sealant.
 - B. Install fasteners wet with BMS 5-95 sealant.
12. Restore original finish per AMM 51-21
13. Reinstall floor panels.
 - A. Install floor panel fasteners with MIL-C-11796, Class 3 corrosion prevention compound. Apply one layer of BMS 10-11, Type I primer to the clip nut. Torque the fasteners 20 to 25 pound-inches.

NOTES

- THIS IS A CATEGORY A REPAIR FOR 757-SF AIRPLANES. THE INSPECTIONS GIVEN IN THE MAINTENANCE PLANNING DATA (MPD) ARE SUFFICIENT TO MAINTAIN THE DAMAGE TOLERANCE OF THE INITIAL STRUCTURE WITH THIS REPAIR INSTALLED. REFER TO SRM 51-00-06 FOR REPAIR CATEGORIES AND DEFINITIONS.
- WHEN USING THIS REPAIR REFER TO:
 - AMM 51-21 FOR INTERIOR AND EXTERIOR FINISHES
 - AMM 51-21 FOR CORROSION PROTECTIVE FINISHES
 - AMM 51-31 FOR SEALS AND SEALING
 - SRM 51-10-02 FOR INSPECTION AND REMOVAL OF DAMAGE
 - SRM 51-20-01 FOR PROTECTIVE TREATMENT OF METALS
 - SRM 51-20-05 FOR SEALING OF REPAIRS
 - SRM 51-40 FOR FASTENER CODE, REMOVAL, INSTALLATION, HOLE SIZES AND EDGE MARGINS

- A** CHAMFER END OF EXISTING SEAT TRACK AND REPAIR PART 1, 0.06 INCH X 45° (1.5 mm x 45°).
- B** QUANTITY INDICATED IS QUANTITY REQUIRED AT EACH CUT LOCATION.
- C** FILL THE GAP BETWEEN REPAIR PART 1 AND THE EXISTING SEAT TRACK WITH BMS 5-95 SEALANT.
- D** REFER TO REPAIR 2 FOR HOLE PATTERN FOR REPAIR PART 1.
- E** ORIGINAL FASTENER LOCATION. USE SAME TYPE AND SIZE FASTENER AS ORIGINAL FASTENER.
- F** NAS8202A5 REPAIR FASTENER LOCATION

Seat Track Repair (BAC1520-841)
Figure 201 (Sheet 1 of 4)

**757-200
STRUCTURAL REPAIR MANUAL**

NOTES (CONT)

G APPLY A CHEMICAL CONVERSION COATING TO THE REWORKED ALUMINUM AREAS. REFER TO 51-20-01.

FOR CUM LINE NUMBERS 2 THRU 476, APPLY ONE LAYER OF BMS 10-11, TYPE I PRIMER.

FOR CUM LINE NUMBERS 478 AND ON, APPLY ONE LAYER OF ALUMINIZED EPOXY PRIMER. REFER TO 20-41-04 OF THE STANDARD OVERHAUL PRACTICES MANUAL D6-51702.

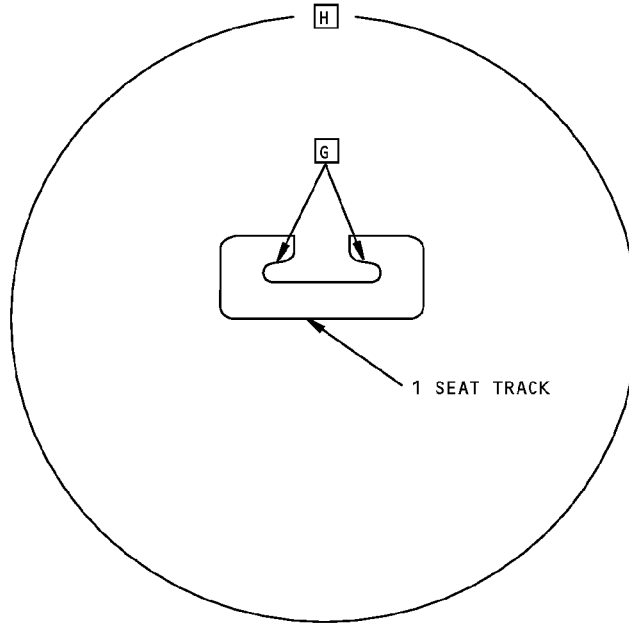
H APPLY A CHEMICAL CONVERSION COATING TO THE REWORKED ALUMINUM AREAS. REFER TO 51-20-01.

FOR CUM LINE NUMBERS 2 THRU 476:

- APPLY ONE LAYER OF BMS 10-11, TYPE I PRIMER
- APPLY ONE LAYER OF BMS 10-86, TYPE I OR TYPE II WHITE URETHANE COATING.

FOR CUM LINE NUMBERS 478 AND ON, APPLY ONE LAYER OF ALUMINIZED EPOXY PRIMER. REFER TO 20-41-04 OF THE STANDARD OVERHAUL PRACTICES MANUAL D6-51702.

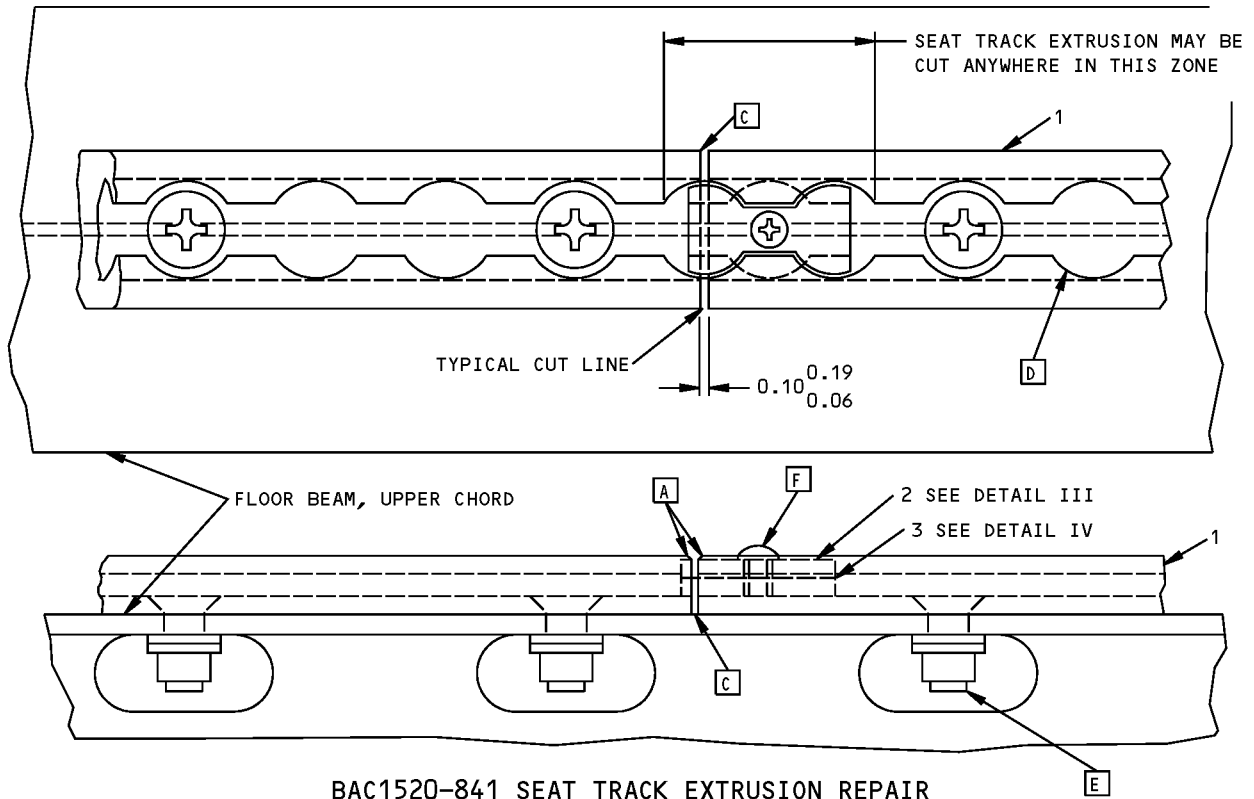
REPAIR MATERIAL			
PART		QTY	MATERIAL
1	SEAT TRACK	1	BAC1520-841 7178-T6511 AS AN ALTERNATIVE USE 7150-T77511
2	PLATE	1 B	0.14 2024-T3 OR T4
3	PLATE	1 B	0.14 2024-T3 OR T4



DETAIL I

**Seat Track Repair (BAC1520-841)
Figure 201 (Sheet 2 of 4)**

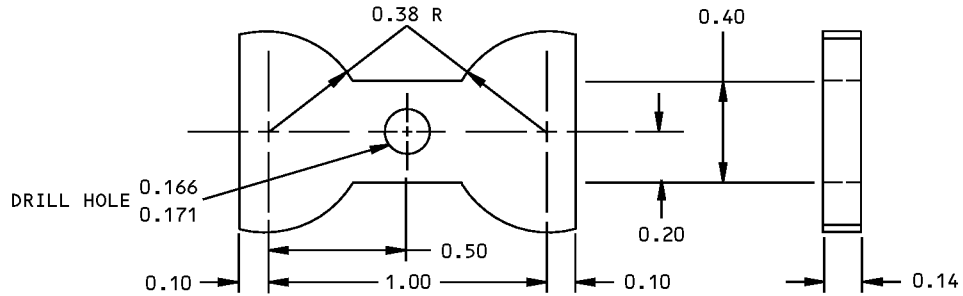
**757-200
STRUCTURAL REPAIR MANUAL**



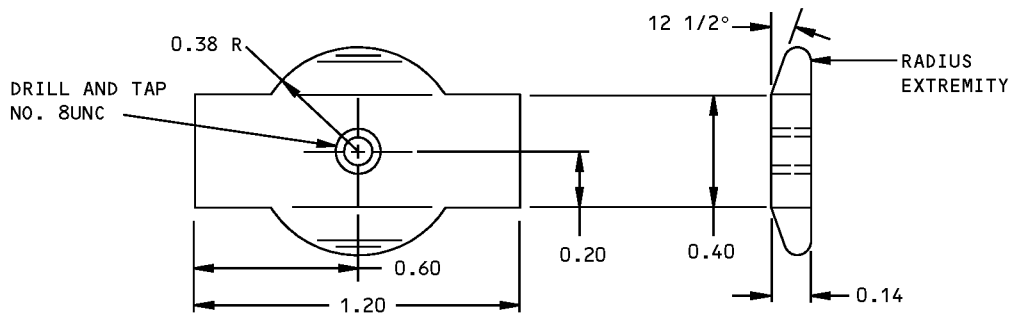
**BAC1520-841 SEAT TRACK EXTRUSION REPAIR
DETAIL II**

**Seat Track Repair (BAC1520-841)
Figure 201 (Sheet 3 of 4)**

**757-200
STRUCTURAL REPAIR MANUAL**



**REPAIR PART 2
DETAIL III**

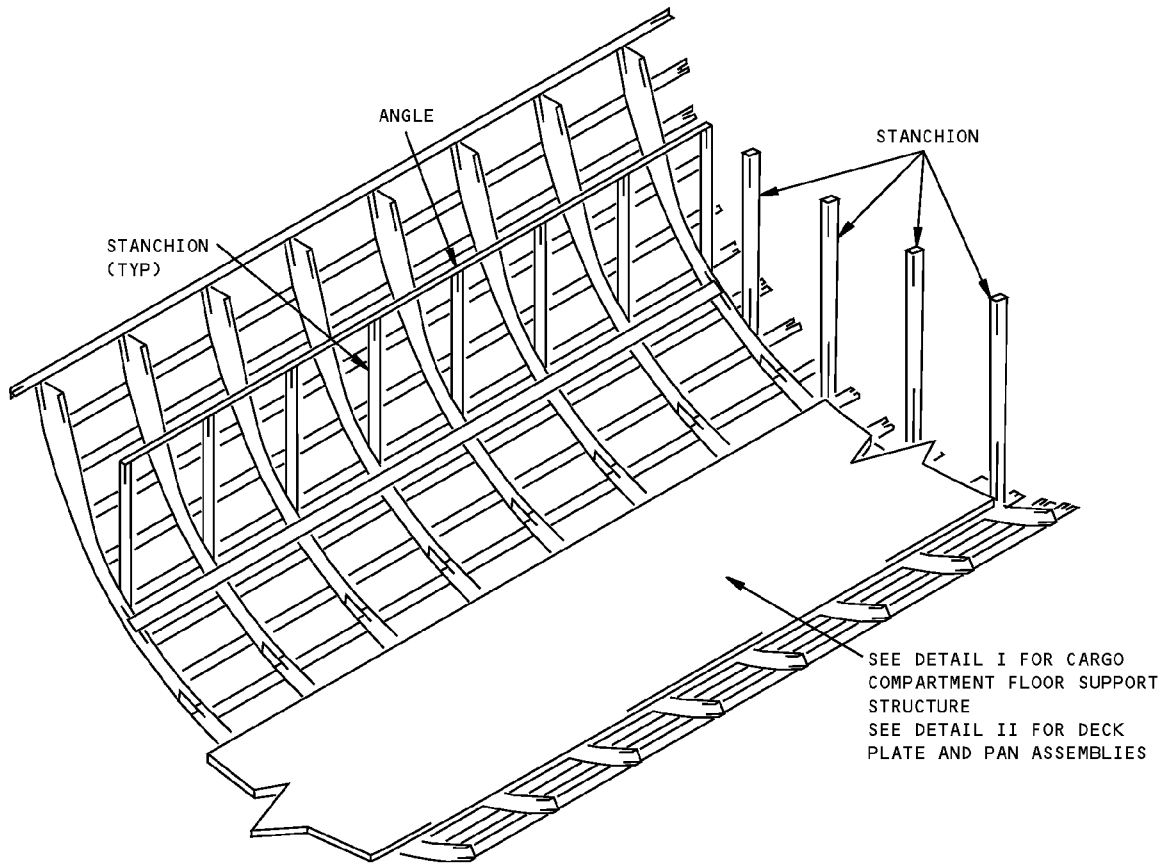


**REPAIR PART 3
DETAIL IV**

**Seat Track Repair (BAC1520-841)
Figure 201 (Sheet 4 of 4)**

**757-200
STRUCTURAL REPAIR MANUAL**

ALLOWABLE DAMAGE 1 - CARGO COMPARTMENT STRUCTURE

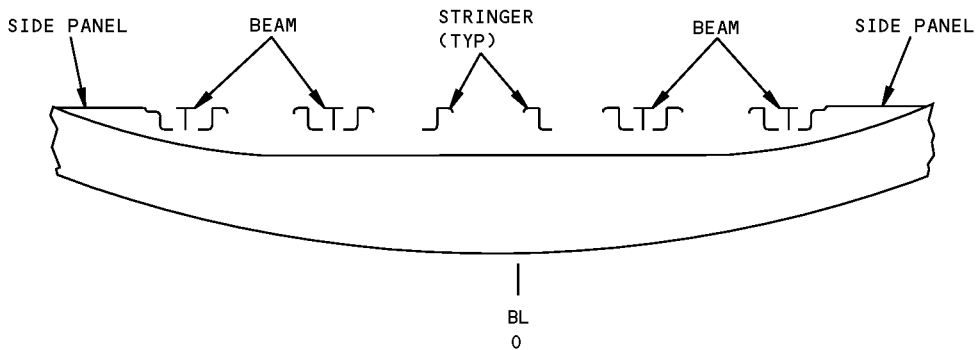
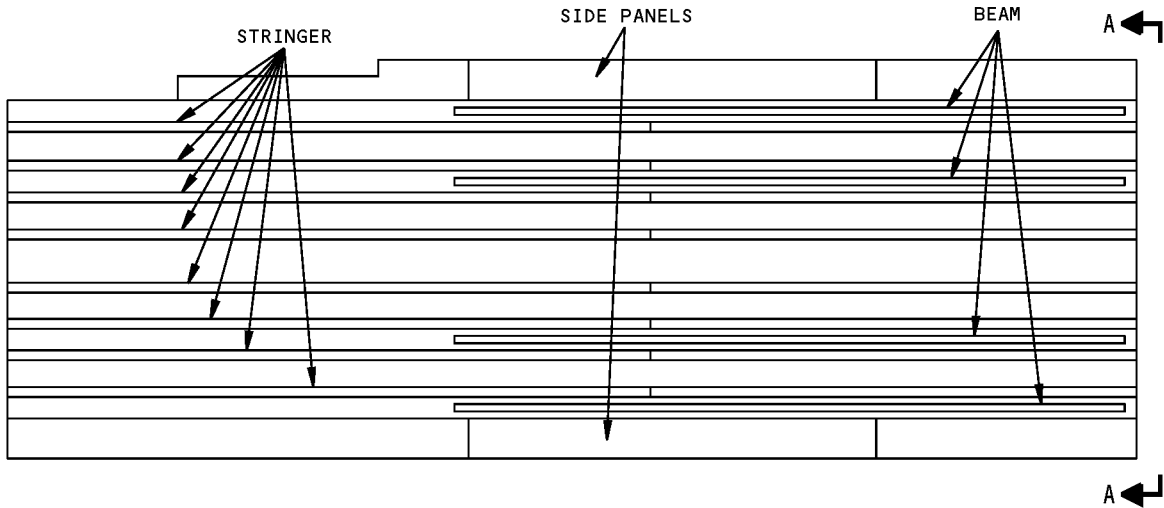


TYPICAL CARGO COMPARTMENT STRUCTURE

DESCRIPTION	CRACKS	NICKS, GOUGES AND CORROSION	DENTS	HOLES AND PUNCTURES	DELAMINATION
STANCHION-AL EXTRUDED	B	C	NOT ALLOWED	NOT ALLOWED	—
STANCHION-GRAPHITE LAMINATE	J	E	F	NOT ALLOWED	NOT ALLOWED
ANGLE-AL	B	C	SEE DETAIL VI	D	—

**Cargo Compartment Structure Allowable Damage
Figure 101 (Sheet 1 of 5)**

**757-200
STRUCTURAL REPAIR MANUAL**

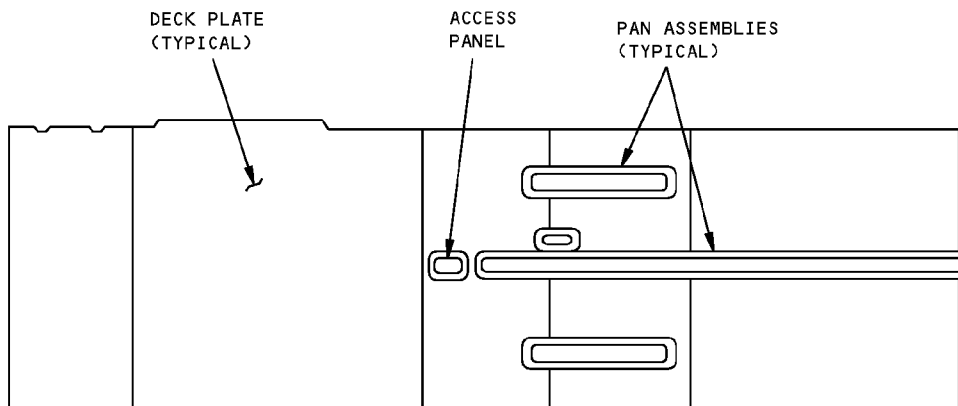


SECTION A-A (ROTATED 90°)
TYPICAL CARGO FLOOR STRUCTURE
DETAIL I

DESCRIPTION	CRACKS	NICKS, GOUGES AND CORROSION	DENTS	HOLES AND PUNCTURES
STRINGER-AL	B	C	NOT ALLOWED	D
BEAM-AL	B	C	NOT ALLOWED	D
SIDE PANEL-AL	B	C	SEE DETAIL VI	D

**Cargo Compartment Structure Allowable Damage
Figure 101 (Sheet 2 of 5)**

**757-200
STRUCTURAL REPAIR MANUAL**



TYPICAL CARGO DECK
DETAIL II

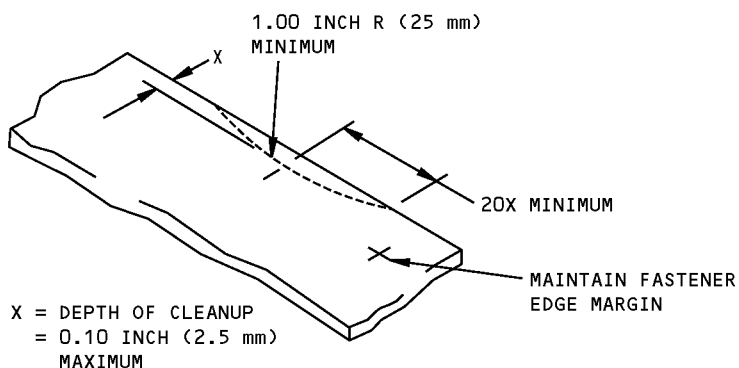
DESCRIPTION	CRACKS	NICKS, GOUGES AND CORROSION	DENTS	HOLES AND PUNCTURES	DELAMINATION
DECK PLATE-AL	G	C	SEE DETAIL VI	D	—
ACCESS PANEL-AL	G	C	SEE DETAIL VI	D	—
PAN-AL	G	C	SEE DETAIL VI	D	—
PAN ASSEMBLY-FIBERGLASS LAMINATE	I	I	I	I	I

**Cargo Compartment Structure Allowable Damage
Figure 101 (Sheet 3 of 5)**

STRUCTURAL REPAIR MANUAL

NOTES

- REFER TO MAINTENANCE MANUAL 25-50-09 FOR REPAIRS TO THE CARGO SIDEWALL LINER. THE LINERS PROVIDE A FIRE AND SMOKE BARRIER.
 - REFINISH REWORKED AREAS PER 51-20 OF THE MAINTENANCE MANUAL.
 - REFER TO SRM 51-10-02 FOR INSPECTION AND REMOVAL OF DAMAGE
 - STANCHIONS WITH DAMAGE EXCEEDING THE LIMITS AS GIVEN MUST BE REPLACED.
 - AT THE NEXT "C" CHECK, REPLACE ANY DAMAGED GRAPHITE STANCHION WITH A NEW STANCHION MADE OF GRAPHITE OR ALUMINUM MATERIAL.
- [A]** REMOVE MOISTURE FROM DAMAGE AREA. USE OF VACUUM AND HEAT (MAX OF 125°F (52°C)) TO REMOVE MOISTURE FROM HONEYCOMB CELLS IS RECOMMENDED. PROTECT DAMAGE FROM ENTRANCE OF WATER, SUNLIGHT OR OTHER FOREIGN MATTER BY SEALING WITH ALUMINUM FOIL TAPE (SPEED TAPE). RECORD THE LOCATION AND INSPECT EVERY AIRPLANE "A" CHECK. REPLACE THE ALUMINUM FOIL TAPE IF ANY PEELING OR DETERIORATION EVIDENT. REPAIR NO LATER THAN NEXT AIRPLANE "C" CHECK **[H]**
- [B]** CRACKS NOT ALLOWED EXCEPT FOR EDGE CRACKS WHICH MUST BE REMOVED PER DETAILS III AND IV
- [C]** REMOVE DAMAGE PER DETAILS III, IV AND V
- [D]** CLEAN OUT DAMAGE UP TO 0.25 INCH (6 mm) MAX DIA AND NOT CLOSER THAN 1.0 INCH (25 mm) TO FASTENER HOLE OR OTHER DAMAGE. FILL HOLE WITH A 2117-T3 OR T4 ALUMINUM RIVET INSTALLED WET WITH BMS 5-95 SEALANT. ALL OTHER HOLES TO BE REPAIRED
- [E]** DAMAGE ALLOWED ON SURFACE RESIN ONLY. DAMAGE TO FIBERS NOT ALLOWED
- [F]** 1.50 INCH (38 mm) MAX DIMENSION ALLOWED PROVIDED THERE IS NO FIBER DAMAGE OR DELAMINATION. ONE DENT PER 6.0 INCH (150 mm) LENGTH OF STANCHION ALLOWED AND A MINIMUM OF 6.0 INCH (150 mm) FROM ANY OTHER DAMAGE
- [G]** 2.0 INCH (50 mm) MAX LENGTH CRACK ALLOWED NOT CLOSER THAN 1.0 INCH (25 mm) TO FASTENER HOLE OR OTHER DAMAGE. STOP DRILL ENDS OF CRACK THAT DO NOT END IN A FASTENER HOLE WITH 0.25 INCH (6 mm) DIAMETER HOLES. FILL THE HOLE WITH A 2117-T3 OR T4 ALUMINUM RIVET INSTALLED WET WITH BMS 5-95 SEALANT. CRACKS BETWEEN THREE ADJACENT FASTENER HOLES AT ATTACHMENT EDGE OF PANEL ARE ALLOWED. REMOVE EDGE DAMAGE PER DETAILS III AND IV
- [H]** THESE ALLOWABLE DAMAGE LIMITS HAVE FAA APPROVAL CONTINGENT ON ACCOMPLISHMENT OF THE INSPECTIONS CONTAINED HEREIN
- [I]** 2.0 INCH (50 mm) MAX DIMENSION ALLOWED NOT CLOSER THAN 1.0 INCH (25 mm) TO FASTENER HOLE OR OTHER DAMAGE. CLEAN UP EDGE DAMAGE PER DETAILS III AND IV **[A]**
- [J]** A CRACK IS PERMITTED IN A CORNER OF A GRAPHITE STANCHION IF THE CRACK DOES NOT EXCEED A MAXIMUM OF 3.00 INCHES (75 mm) IN LENGTH, REFER TO DETAIL VII.

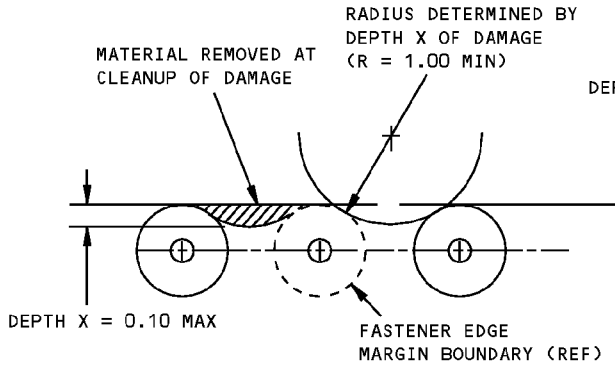


REMOVAL OF NICK OR CRACK DAMAGE ON AN EDGE

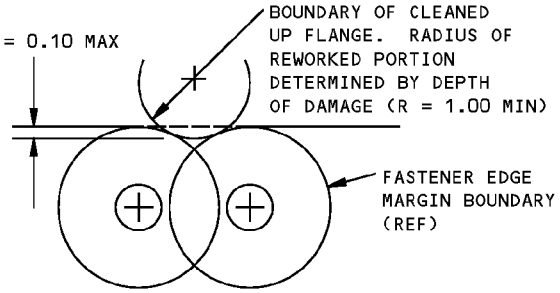
DETAIL III

Cargo Compartment Structure Allowable Damage
Figure 101 (Sheet 4 of 5)

STRUCTURAL REPAIR MANUAL

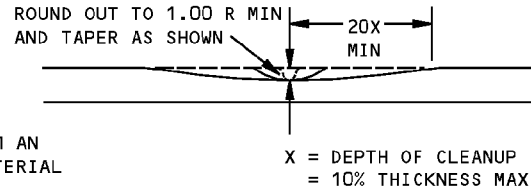
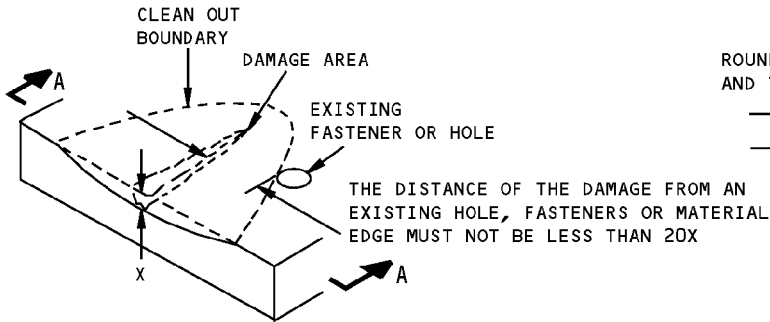


DAMAGE CLEANUP OF EDGES WHERE FASTENER EDGE MARGINS DO NOT OVERLAP



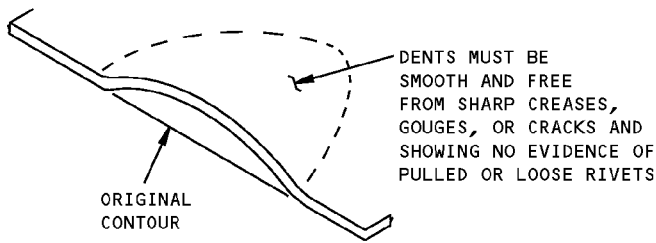
DAMAGE CLEANUP OF EDGES WHERE FASTENER EDGE MARGINS OVERLAP

DETAIL IV

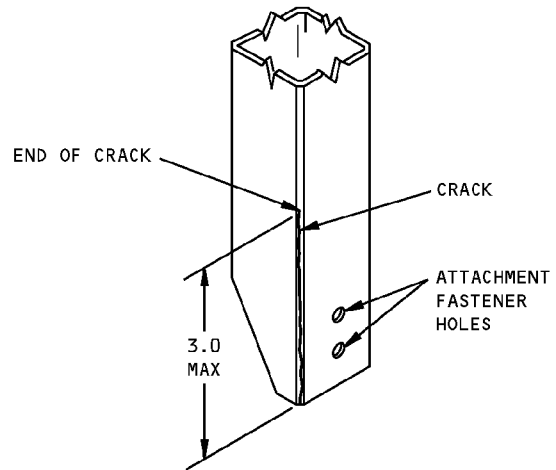


SECTION A-A

REMOVAL OF NICK, GOUGE AND SCRATCH DAMAGE ON A SURFACE
DETAIL V



ALLOWABLE DAMAGE FOR DENT
DETAIL VI



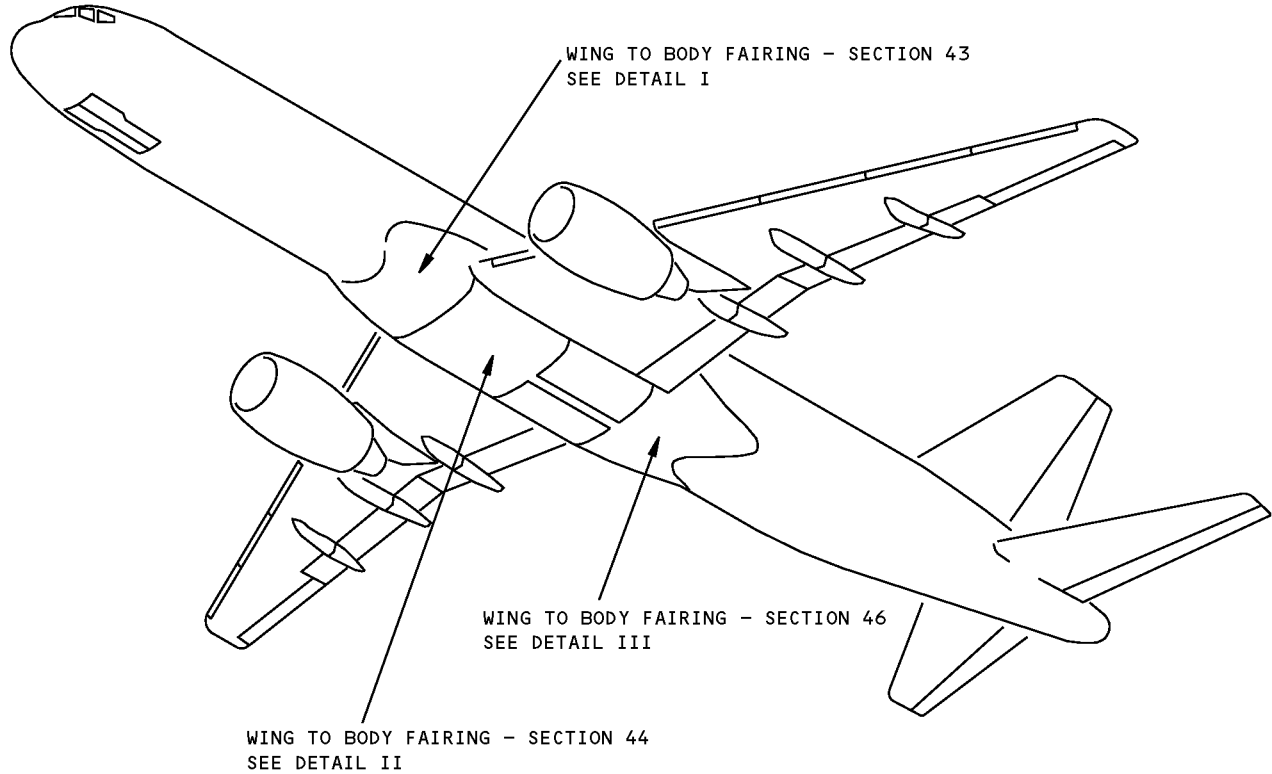
GRAPHITE STANCHION CRACK
DETAIL VII

**Cargo Compartment Structure Allowable Damage
Figure 101 (Sheet 5 of 5)**



757-200
STRUCTURAL REPAIR MANUAL

ALLOWABLE DAMAGE 1 - WING TO BODY FAIRING SKIN



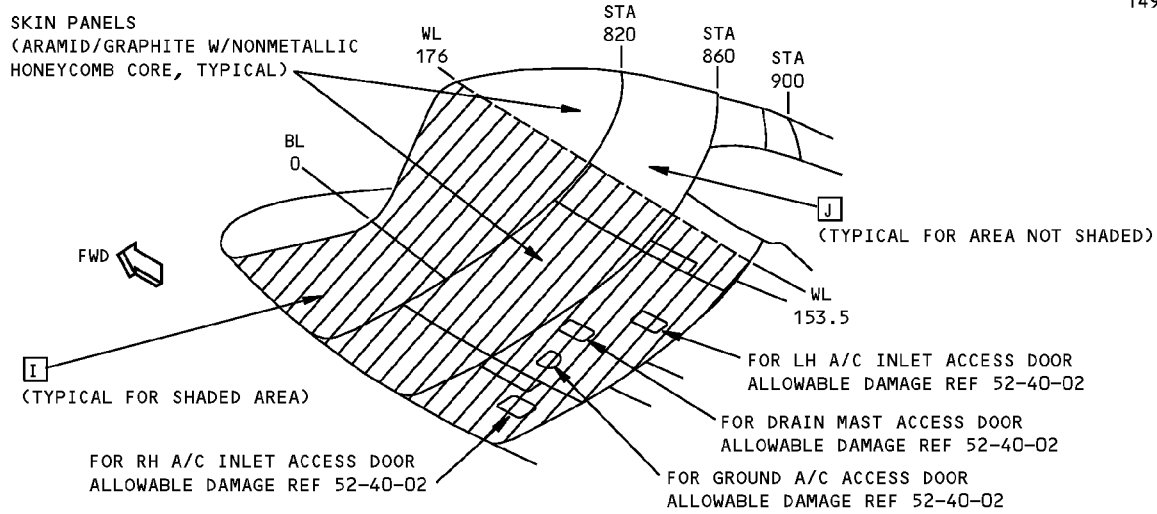
Wing to Body Fairing Skin Allowable Damage
Figure 101 (Sheet 1 of 5)

D634N201

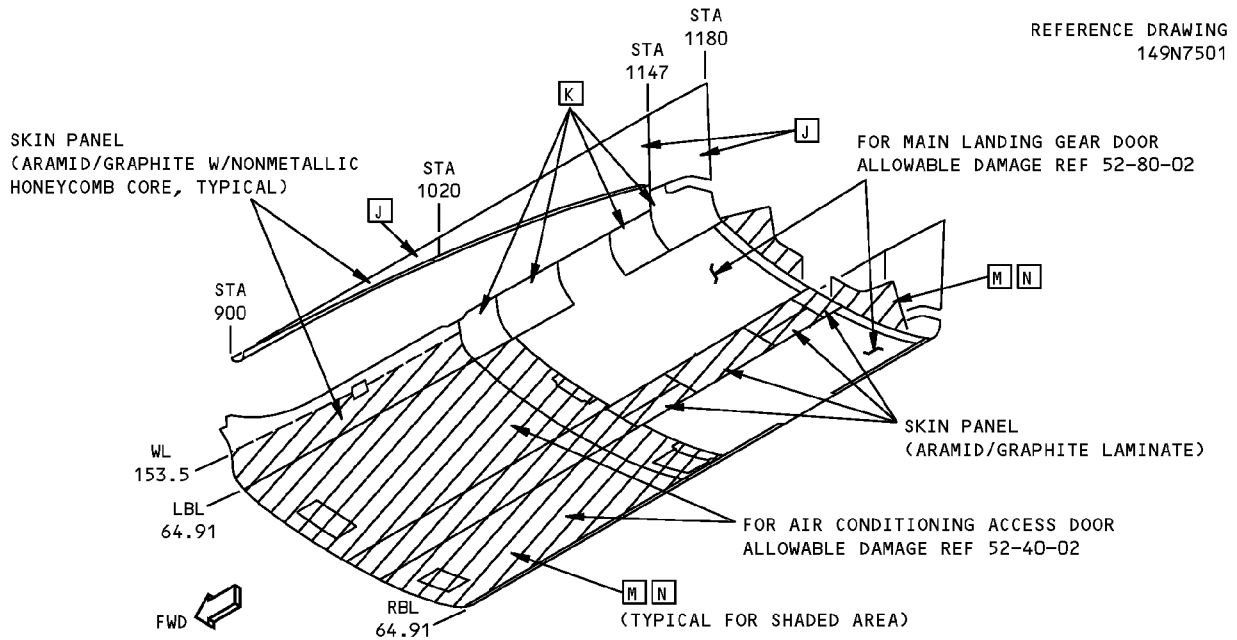
ALLOWABLE DAMAGE 1
Page 101
53-00-70
Jan 20/2005

**757-200
STRUCTURAL REPAIR MANUAL**

REFERENCE DRAWING
149N7101



LEFT SIDE SHOWN
RIGHT SIDE OPPOSITE
WING-TO-BODY FAIRING - SECTION 43
DETAIL I

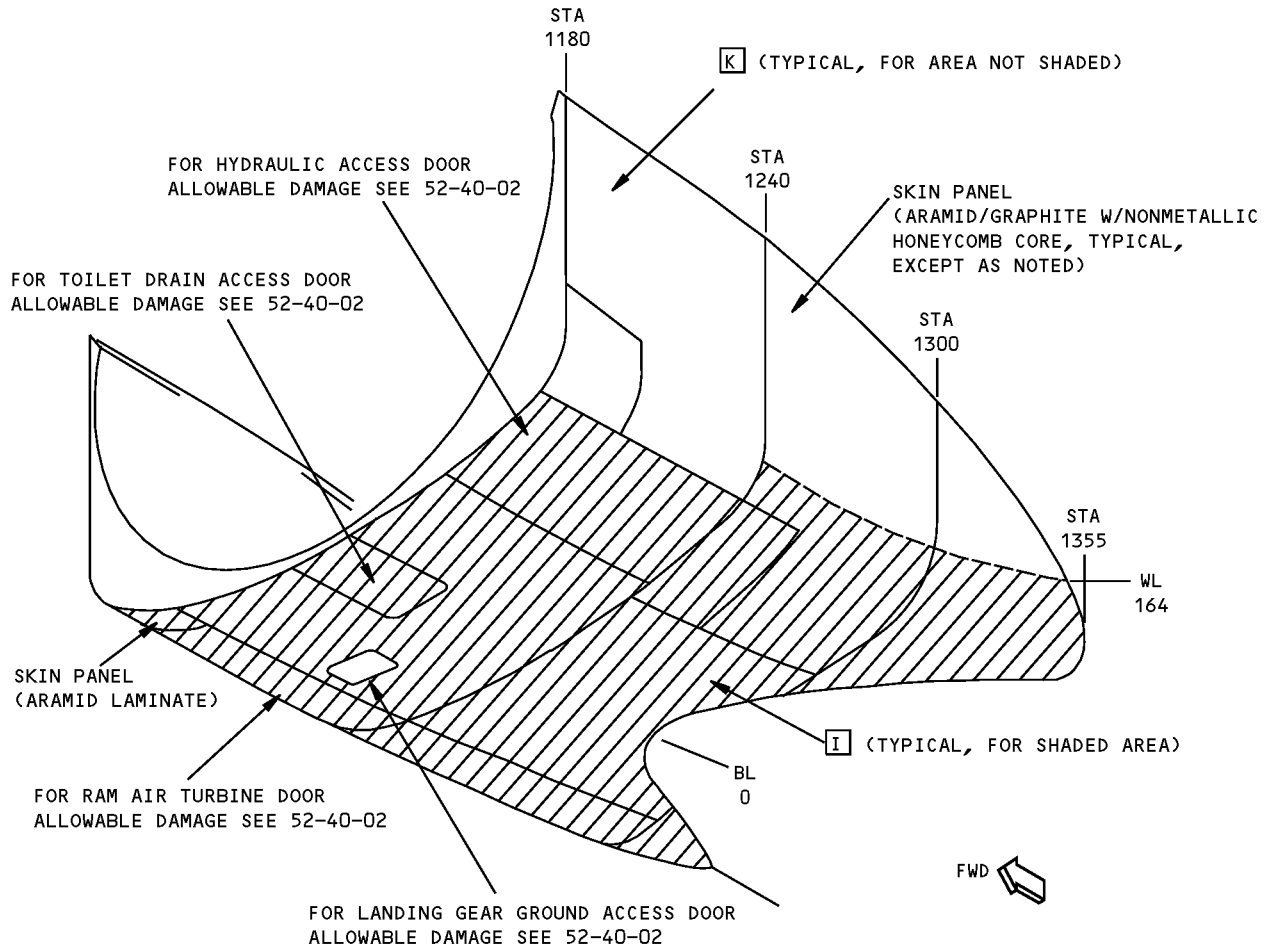


LEFT SIDE SHOWN
RIGHT SIDE OPPOSITE
WING-TO-BODY FAIRING - SECTION 44
DETAIL II

**Wing to Body Fairing Skin Allowable Damage
Figure 101 (Sheet 2 of 5)**

**757-200
STRUCTURAL REPAIR MANUAL**

REF DWG
149N7601

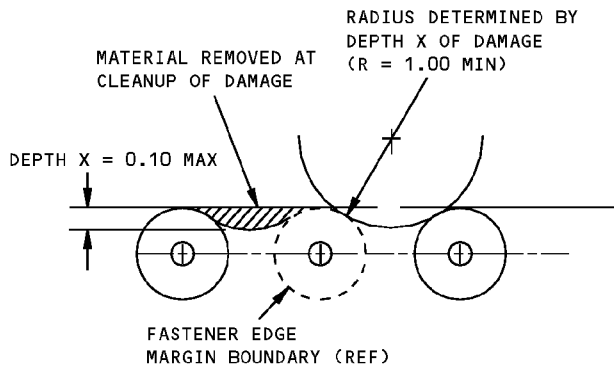


DETAIL III

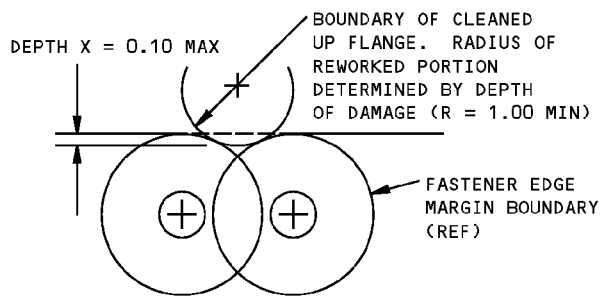
**Wing to Body Fairing Skin Allowable Damage
Figure 101 (Sheet 3 of 5)**

STRUCTURAL REPAIR MANUAL

DESCRIPTION	CRACKS	NICKS, GOUGES AND CORROSION	DENTS	HOLES AND PUNCTURES	DELAMINATION	EDGE EROSION
SKIN PANEL (ARAMID/GRAPHITE W/HONEYCOMB CORE)	B	C	D	E	F	SEE DETAIL V
SKIN PANEL (ARAMID OR ARAMID/GRAPHITE LAMINATE)	G	C	NOT ALLOWED	H	L	SEE DETAIL V

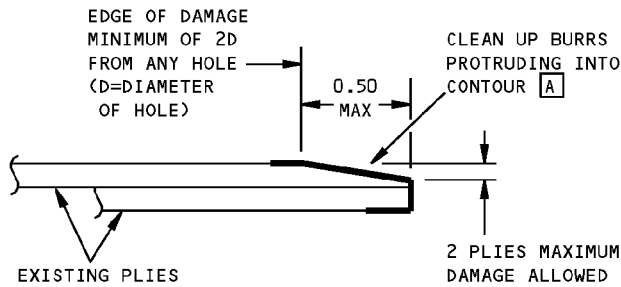


DAMAGE CLEANUP OF EDGES WHERE FASTENER EDGE MARGINS DO NOT OVERLAP



DAMAGE CLEANUP OF EDGES WHERE FASTENER EDGE MARGINS OVERLAP

DETAIL IV



DAMAGE CLEANUP AND SEALING OF EDGE EROSION

DETAIL V

Wing to Body Fairing Skin Allowable Damage
Figure 101 (Sheet 4 of 5)

STRUCTURAL REPAIR MANUAL

NOTES

- REFINISH REWORKED AREAS PER 51-20 OF THE MAINTENANCE MANUAL
- REFER TO SRM 51-10-01 FOR AERODYNAMIC SMOOTHNESS REQUIREMENTS. WHERE THE DAMAGE EXCEEDS THE LIMITS SHOWN IN 51-10-01, CONSIDERATION SHOULD BE GIVEN TO THE LOSS OF PERFORMANCE INVOLVED
- REFER TO SRM 51-10-02 FOR INSPECTION AND REMOVAL OF DAMAGE
- TYPICAL DAMAGE TO A PANEL EDGE BAND MAY CONSIST OF EDGE CRUSHING, CRACKS OR DELAMINATION. DAMAGE AROUND HOLES MAY CONSIST OF OVALIZATION, FASTENER PULL-THROUGH OR CRACKS OUT OF HOLE. DAMAGE MAY REDUCE THE EFFECTIVE CROSS-SECTIONAL AREA OF AN EDGE BAND. DAMAGE TO EDGES SHOULD BE BLENDED OUT TO LIMITATIONS GIVEN FOR COMPONENT

A PROTECT DAMAGE FROM ENTRANCE OF WATER, SUNLIGHT OR OTHER FOREIGN MATTER BY SEALING WITH ALUMINUM FOIL TAPE (SPEED TAPE) 3M-Y436 OR EQUIVALENT. RECORD LOCATION AND INSPECT AT AIRPLANE "A" CHECK. REPLACE ALUMINUM FOIL TAPE IF ANY PEELING OR DETERIORATION OF TAPE IS EVIDENT. REPAIR DAMAGE PER SRM 51-70 NO LATER THAN THE NEXT "C" CHECK **D**

B 2.0 INCHES (50 mm) MAX LENGTH IN ACESHEETS OF HONEYCOMB AREA NOT CLOSER THAN 10 INCHES (250 mm) TO ANY OTHER CRACK. ONE CRACK PER SQUARE FOOT OF AREA ALLOWED. FOR CRACKS IN EDGE BAND AREA SEE **G**. **A**

C DAMAGE ALLOWED ON SURFACE RESIN ONLY. DAMAGE TO FIBERS NOT ALLOWED. CLEAN UP EDGE DAMAGE PER DETAIL IV **A**

D DENTS GENERALLY RESULT IN FIBER DAMAGE OR DELAMINATION. HOWEVER, IF THERE IS NO FIBER DAMAGE OR DELAMINATION, DENTS UP TO 1.5 INCH (38 mm) DIA MAX ARE ALLOWED. ONE DENT PER SQUARE FOOT OF AREA ALLOWED WHICH MUST BE A MINIMUM OF 6 INCHES (150 MM) FROM ANY OTHER DAMAGE, FASTENER HOLE, OR PANEL EDGE. SEE **E** OR **F** IF FIBER DAMAGE OR DELAMINATION IS PRESENT

E 1.0 INCH (25 mm) MAX DIA IS ALLOWED IN HONEYCOMB AREA ONLY PROVIDED DAMAGE IS MIN OF 2.5 D FROM OTHER DAMAGE, NEAREST HOLE, OR MATERIAL EDGE. DO NOT CLEAN UP DAMAGE EXCEPT TO REMOVE RESIN BURRS EXTENDING INTO SURFACE CONTOUR **A**

F 1.0 INCH (25 mm) MAX DIA IS ALLOWED IN HONEYCOMB AREA. A MAXIMUM OF 0.10 INCH DELAMINATION FROM EDGE IS ALLOWED. REPAIR DELAMINATION IN HONEYCOMB AREA PER SRM 51-70 NO LATER THAN THE NEXT "C" CHECK. PROTECT EDGE DAMAGE PER **A**

G 1.0 INCH (25 mm) MAX LENGTH PER SQUARE FOOT OF AREA AND A MIN OF 6.0 INCHES (150 mm) FROM ANY OTHER CRACK. CLEAN UP EDGE CRACKS PER DETAIL IV. CRACKS THROUGH TWO CONSECUTIVE FASTENERS THROUGH THE EDGE BAND ARE ALLOWED **A**

H 0.25 INCH (6 mm) MAX DIA ALLOWED PROVIDED DAMAGE IS MIN OF 2.50 D FROM OTHER DAMAGE, NEAREST HOLE, OR MATERIAL EDGE. DO NOT CLEAN UP DAMAGE EXCEPT TO REMOVE RESIN BURRS EXTENDING INTO SURFACE CONTOUR **A**

I OUTER PLY - THORSTRAND FABRIC ON COMPOSITE PANELS IN THIS AREA (SHADED). FOR ALLOWABLE DAMAGE SEE SRM 51-70-14

J CONDUCTIVE COATING ON EXTERIOR OF COMPOSITE PANELS IN THIS AREA. FOR ALLOWABLE DAMAGE, SEE SRM 51-70-14

K FOR CUM LINE NUMBERS:
1 THRU 9
SEE **I**

FOR CUM LINE NUMBERS:
10 AND ON
SEE **J**

L 1.0 INCH (25 mm) MAX DIA IS ALLOWED. A MAXIMUM OF 0.10 INCH (2.5 mm) DEALAMINATION FROM EDGE IS ALLOWED. PROTECT EDGE DAMAGE PER **A**

M FOR CUM LINE NUMBERS:
1 THRU 42
OUTER PLY - THORSTRAND FABRIC ON COMPOSITE PANELS IN THIS AREA (SHADED). FOR ALLOWABLE DAMAGE, SRM 51-70-14

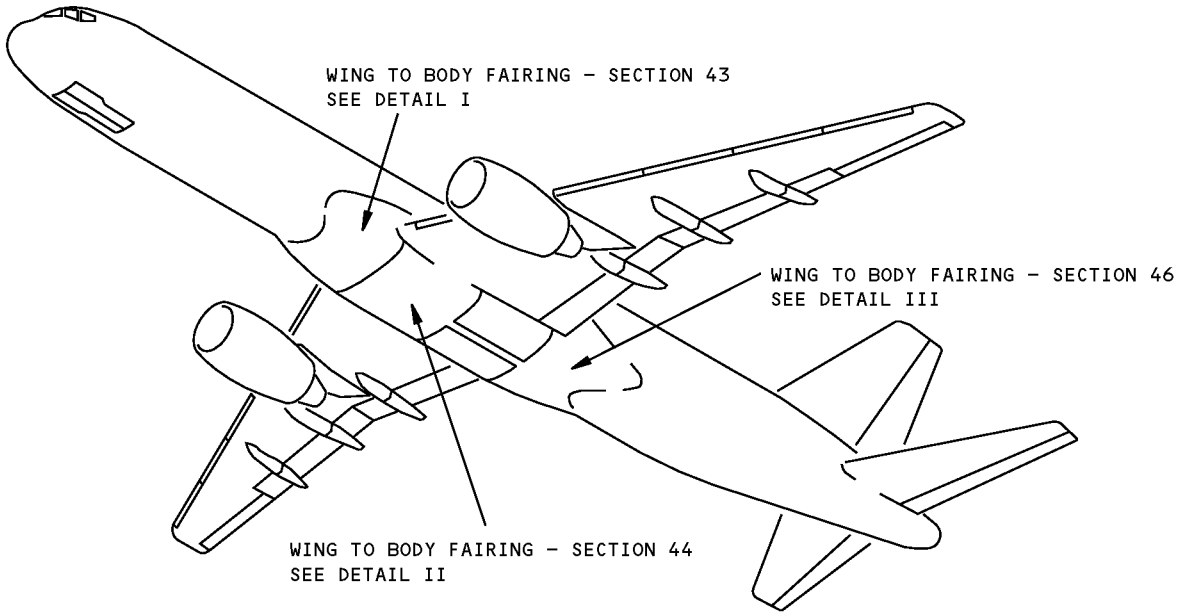
N FOR CUM LINE NUMBERS:
43 AND ON
CONDUCTIVE COATING ON EXTERIOR OF COMPOSITE PANELS IN THIS AREA. FOR ALLOWABLE DAMAGE, SRM 51-70-14

O THESE ALLOWABLE DAMAGE LIMITS HAVE FAA APPROVAL CONTINGENT ON ACCOMPLISHMENT OF THE INSPECTIONS CONTAINED HEREIN

Wing to Body Fairing Skin Allowable Damage
Figure 101 (Sheet 5 of 5)

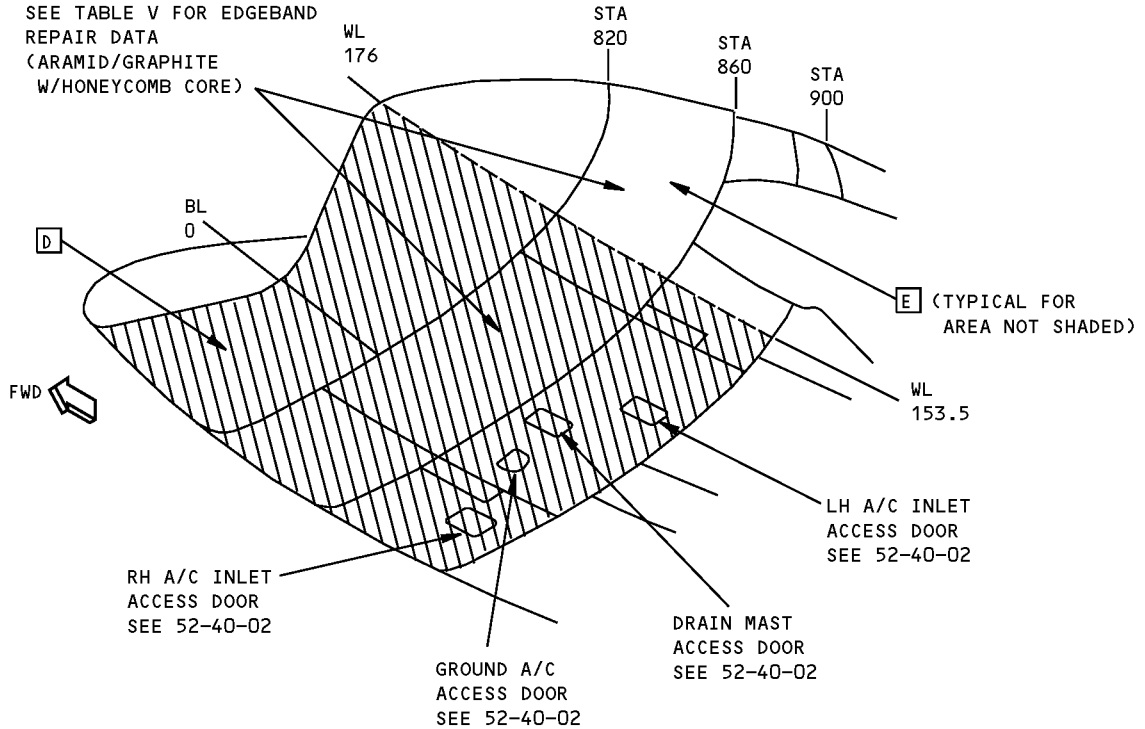
**757-200
STRUCTURAL REPAIR MANUAL**

REPAIR 1 - WING TO BODY FAIRING SKIN REPAIRS



SKIN PANELS (TYP) -
SEE TABLE II FOR HONEYCOMB
AREA REPAIR DATA
SEE TABLE V FOR EDGE BAND
REPAIR DATA
(ARAMID/GRAPHITE
W/HONEYCOMB CORE)

REF DWG
149N7101

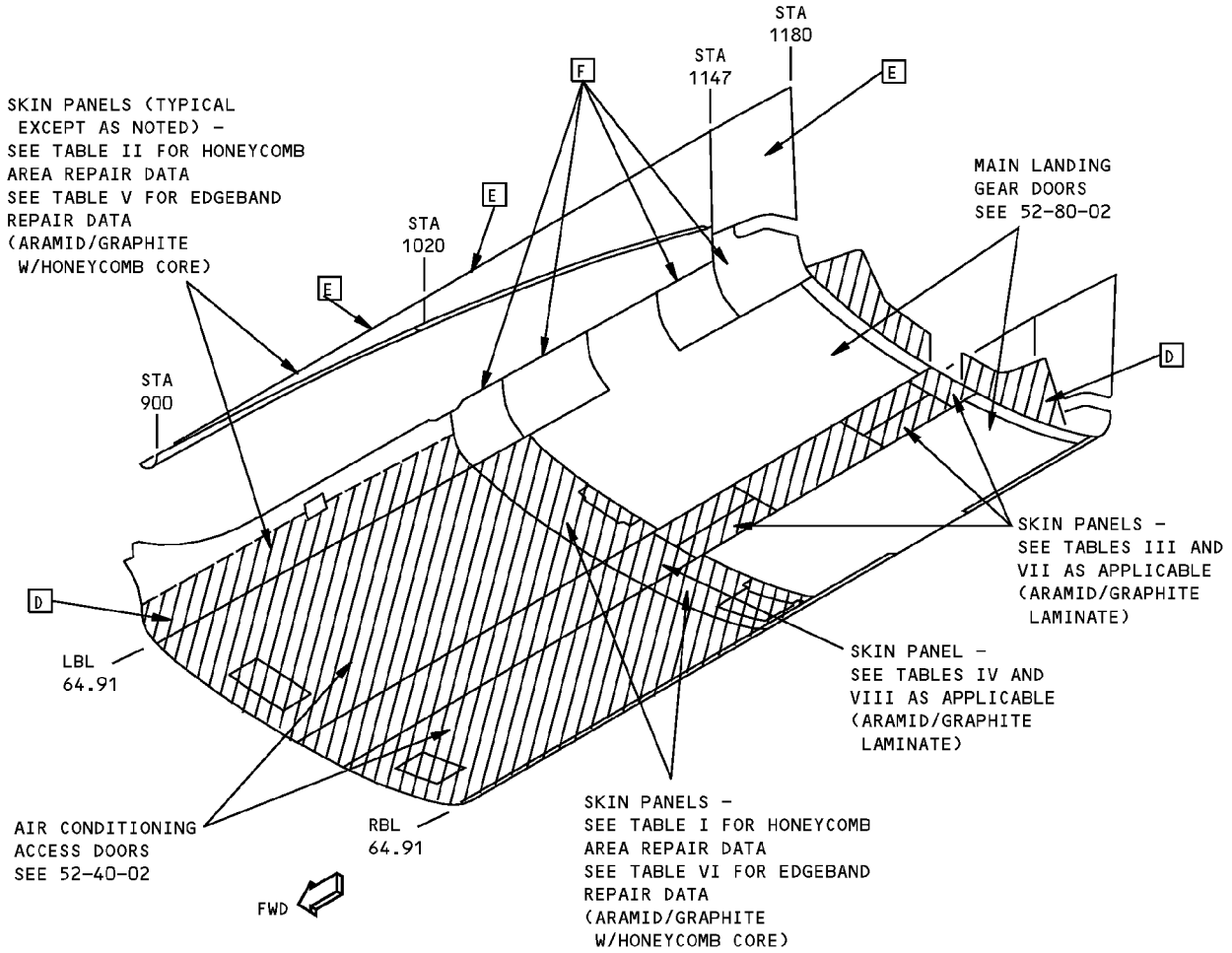


LEFT SIDE SHOWN
RIGHT SIDE OPPOSITE

**Wing To Body Fairing Skin Repairs
Figure 201 (Sheet 1 of 12)**

**757-200
STRUCTURAL REPAIR MANUAL**

REF DWG
149N7501

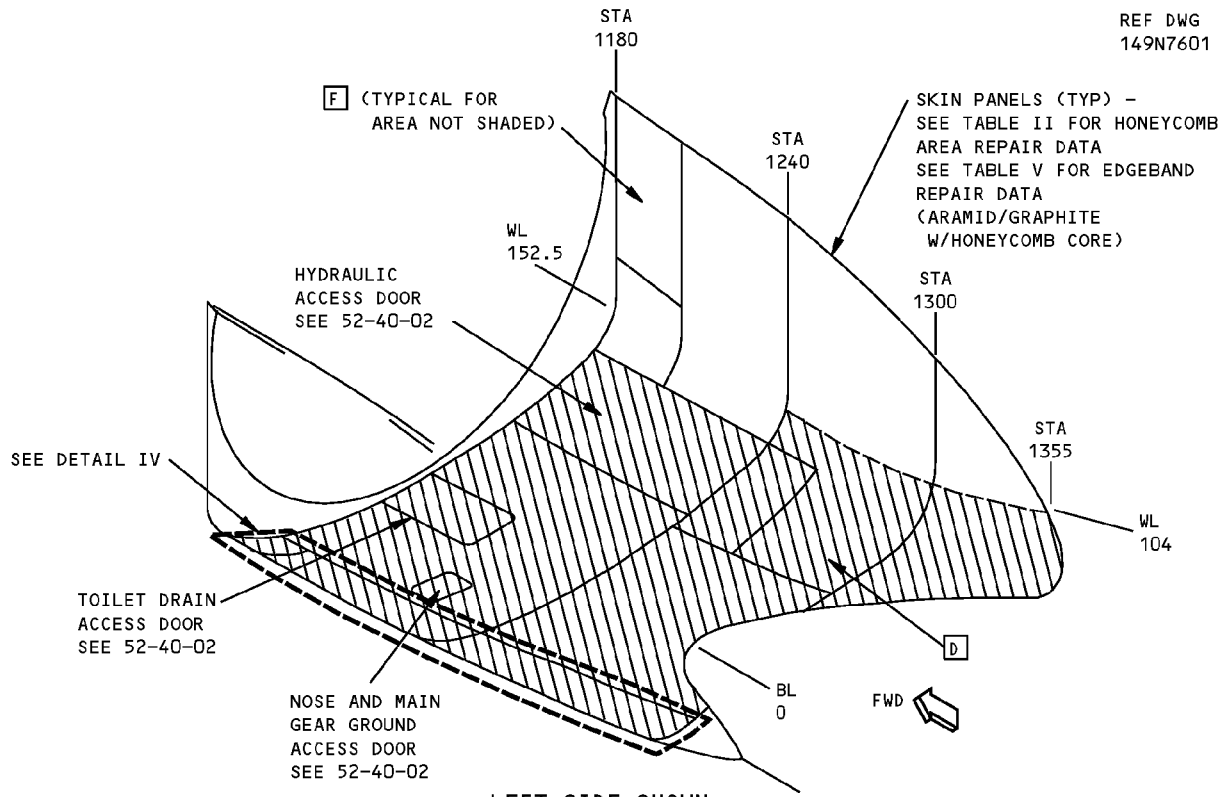


LEFT SIDE SHOWN
RIGHT SIDE OPPOSITE
WING TO BODY FAIRING - SECTION 44
DETAIL II

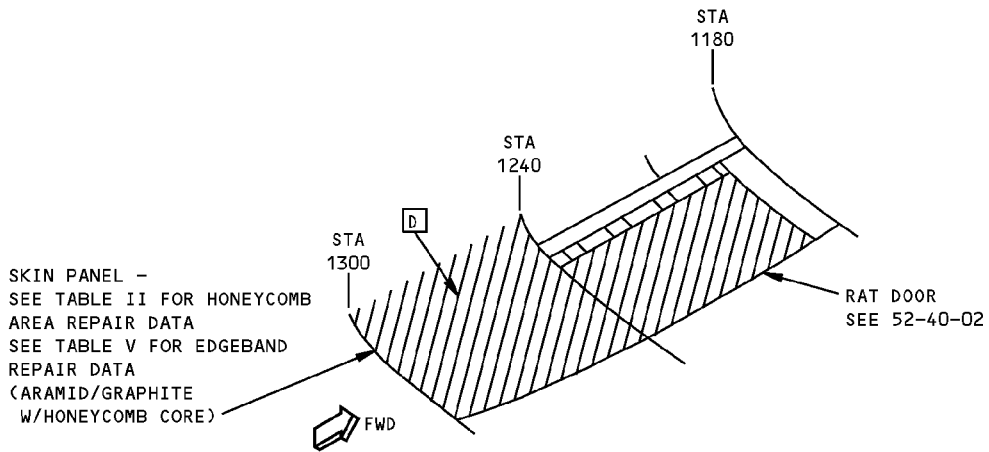
**Wing To Body Fairing Skin Repairs
Figure 201 (Sheet 2 of 12)**

**757-200
STRUCTURAL REPAIR MANUAL**

REF DWG
149N7601



LEFT SIDE SHOWN
RIGHT SIDE OPPOSITE EXCEPT AS NOTED
WING TO BODY FAIRING - SECTION 46
DETAIL III



RIGHT SIDE ONLY
WING TO BODY FAIRING - SECTION 46
DETAIL IV

**Wing To Body Fairing Skin Repairs
Figure 201 (Sheet 3 of 12)**

STRUCTURAL REPAIR MANUAL

NOTES

- REFINISH REWORKED AREAS AS SHOWN IN AMM 51-20
 - REFER TO SRM 51-10-01 FOR AERODYNAMIC SMOOTHNESS REQUIREMENTS. WHERE THE DAMAGE EXCEEDS THE LIMITS SHOWN IN SRM 51-10-01, CONSIDERATION SHOULD BE GIVEN TO THE LOSS OF PERFORMANCE INVOLVED
 - REFER TO 51-10-02 FOR INSPECTION AND REMOVAL OF DAMAGE
- [A] LIMITED TO REPAIR OF DAMAGE TO ONE FACE-SHEET SKIN AND HONEYCOMB CORE. ONE REPAIR PER SQUARE FOOT OF AREA AND MINIMUM OF 6.0 INCHES (150 mm) (EDGE TO EDGE) FROM ANY OTHER DAMAGE, FASTENER HOLE, EDGE OF PANEL, OR A MINIMUM OF 2.0 INCHES (50 mm) FROM TAPERED EDGE OF HONEYCOMB CORE
- [B] ONE REPAIR PER SQUARE FOOT OF AREA AND A MINIMUM OF 6.0 INCHES (150 mm) (EDGE TO EDGE) FROM ANY OTHER DAMAGE, FASTENER HOLE, EDGE OF PANEL, OR A MINIMUM OF 2.0 INCHES (50 mm) FROM TAPERED EDGE OF HONEYCOMB CORE
- [C] INSPECT INTERIM REPAIR USING INSTRUMENTED NDI METHODS OR "TAP" TEST EVERY AIRPLANE "2A" CHECK. FOR "TAP" TEST, USE A SOLID METAL DISK AND TAP THE REPAIR AREA LIGHTLY BUT FIRMLY. VOID AREAS WILL PRODUCE A DULL SOUND AS OPPOSED TO A SHARP RING ON A SOLID BONDED AREA. PERMANENT REPAIR IS REQUIRED IF ANY DETERIORATION IS EVIDENT. REFER TO SRM 51-70-03, PAR. 4.I. AND THE NON-DESTRUCTIVE TEST MANUAL [H]
- [D] OUTER PLY-THORSTRAND FABRIC ON COMPOSITE PANELS IN THIS AREA (SHADED) PROVIDED FOR LIGHTNING PROTECTION. DAMAGE IN TABLE APPLIES TO STRUCTURE UNDER THE THORSTRAND PLY. REFER TO SRM 51-70-14 FOR REPAIR OF THORSTRAND FABRIC
- [E] CONDUCTIVE COATING ON EXTERIOR OF COMPOSITE PANELS IN THIS AREA. REFER TO AMM 51-20 FOR REPAIR OF CONDUCTIVE COATING
- [F] FOR CUM LINE NUMBERS:
1 THRU 9, SEE [D]
FOR CUM LINE NUMBERS:
10 AND ON, SEE [E]
- [G] ONE REPAIR PER SQUARE FOOT OF AREA AND A MINIMUM OF 3.0 INCHES (75 mm) (EDGE TO EDGE) FROM ANY OTHER DAMAGE, FASTENER HOLE, OR EDGE OF PANEL
- [H] THIS REPAIR HAS FAA APPROVAL CONTINGENT ON ACCOMPLISHMENT OF THE INSPECTIONS CONTAINED HEREIN

Wing To Body Fairing Skin Repairs
Figure 201 (Sheet 4 of 12)



**757-200
STRUCTURAL REPAIR MANUAL**

DAMAGE	INTERIM REPAIRS C	PERMANENT REPAIRS		
	WET LAYUP 150°F (66°C) CURE (SRM 51-70-03)	WET LAYUP 200°F (93°C) CURE (SRM 51-70-17)	250°F (121°C) CURE (SRM 51-70-05)	350°F (177°C) CURE (SRM 51-70-04)
CRACKS	UP TO 3.0 INCHES (75 mm) LONG, REPAIR WITH PATCH AS GIVEN IN SRM 51-70-03, PAR. 5.N. A	CLEAN UP DAMAGE AND REPAIR AS A HOLE.	CLEAN UP DAMAGE AND REPAIR AS A HOLE.	CLEAN UP DAMAGE AND REPAIR AS A HOLE.
HOLES	2.0 INCH (50 mm) MAXIMUM DIA NOT TO EXCEED 30% OF SMALLEST DIMENSION ACROSS HONEYCOMB PANEL AT THE DAMAGE LOCATION. FILL WITH BMS 5-28, TYPE 7 POTTING COMPOUND AND PATCH AS GIVEN IN SRM 51-70-03, PAR. 5.N. A	6.0 INCHES (150 mm) MAXIMUM DIA NOT TO EXCEED 50% OF SMALLEST DIMENSION ACROSS HONEYCOMB PANEL AT THE DAMAGE LOCATION. USE TWO EXTRA PLIES FOR EACH FACESHEET REPAIRED B	4.0 INCHES (100 mm) MAXIMUM DIA NOT TO EXCEED 50% OF SMALLEST DIMENSION ACROSS HONEYCOMB PANEL AT THE DAMAGE LOCATION. USE TWO EXTRA PLIES FOR EACH FACESHEET REPAIRED B	NO SIZE LIMIT
DELAMI-NATION	CUT OUT AND REPAIR AS A HOLE.			
NICKS AND GOUGES	IF THERE IS NO FIBER DAMAGE OR DELAMINATION, FILL NICKS OR GOUGES AS GIVEN IN SRM 51-70-03. IF YOU FIND FIBER DAMAGE OR DELAMINATION, THEN REPAIR AS A HOLE.			
DENTS	UP TO 2.0 INCHES (50 mm) DIA WITH NO FIBER DAMAGE OR DELAMINATION, FILL WITH BMS 5-28, TYPE 7 POTTING COMPOUND AND PATCH AS GIVEN IN SRM 51-70-03, PAR. 5.L. B OVER 2.0 INCHES (50 mm) DIA OR WITH FIBER DAMAGE OR DELAMINATION, REPAIR AS A HOLE.			

REPAIR DATA FOR 350°F (177°C) CURE HONEYCOMB PANELS
TABLE I

**Wing To Body Fairing Skin Repairs
Figure 201 (Sheet 5 of 12)**



**757-200
STRUCTURAL REPAIR MANUAL**

DAMAGE	INTERIM REPAIRS C	PERMANENT REPAIRS		
	WET LAYUP ROOM TEMP (SRM 51-70-03)	WET LAYUP 150°F (66°C) CURE (SRM 51-70-03)	WET LAYUP 200°F (93°C) CURE (SRM 51-70-17)	250°F (121°C) CURE (SRM 51-70-05)
CRACKS	UP TO 4.0 INCHES (100 mm) LONG, REPAIR WITH PATCH AS GIVEN IN SRM 51-70-03, PAR. 5.N. A	CLEAN UP DAMAGE AND REPAIR AS A HOLE	CLEAN UP DAMAGE AND REPAIR AS A HOLE	CLEAN UP DAMAGE AND REPAIR AS A HOLE
HOLES	4.0 INCHES (100 mm) MAX DIA NOT TO EXCEED 30% OF SMALLEST DIMENSION ACROSS HONEYCOMB PANEL AT THE DAMAGE LOCATION. FILL WITH BMS 5-28, TYPE 7 POTTING COMPOUND AND PATCH AS GIVEN IN SRM 51-70-03, PAR. 5.N. A	8.0 INCHES (200 mm) MAXIMUM DIA NOT TO EXCEED 50% OF SMALLEST DIMENSION ACROSS HONEYCOMB PANEL AT THE DAMAGE LOCATION. USE TWO EXTRA PLIES FOR EACH FACESHEET REPAIRED B	12.0 INCHES (300 mm) MAXIMUM DIA NOT TO EXCEED 50% OF SMALLEST DIMENSION ACROSS HONEYCOMB PANEL AT THE DAMAGE LOCATION. USE TWO EXTRA PLIES FOR EACH FACESHEET REPAIRED B	NO SIZE LIMIT
DELAMI-NATION	CUT OUT AND REPAIR AS A HOLE			
NICKS AND GOUGES	IF THERE IS NO FIBER DAMAGE OR DELAMINATION, FILL NICKS OR GOUGES AS GIVEN IN SRM 51-70-03 IF YOU FIND FIBER DAMAGE OR DELAMINATION, THEN REPAIR AS A HOLE			
DENTS	UP TO 2.0 INCHES (50 mm) DIA WITH NO FIBER DAMAGE OR DELAMINATION, FILL WITH BMS 5-28, TYPE 7 POTTING COMPOUND AND PATCH AS GIVEN IN SRM 51-70-03, PAR. 5.L. C OVER 2.0 INCHES (50 mm) DIA OR WITH FIBER DAMAGE OR DELAMINATION, REPAIR AS A HOLE			

REPAIR DATA FOR 250°F (121°C) CURE HONEYCOMB PANELS
TABLE II

**Wing To Body Fairing Skin Repairs
Figure 201 (Sheet 6 of 12)**



**757-200
STRUCTURAL REPAIR MANUAL**

DAMAGE	INTERIM REPAIRS C	PERMANENT REPAIRS		
	WET LAYUP ROOM TEMP (SRM 51-70-03)	WET LAYUP 150°F (66°C) CURE (SRM 51-70-03)	WET LAYUP 200°F (93°C) CURE (SRM 51-70-17)	250°F (121°C) CURE (SRM 51-70-05)
CRACKS	UP TO 2.0 INCHES (50 mm) LONG, REPAIR WITH PATCH AS GIVEN IN SRM 51-70-03, PAR. 5.N. G	CLEAN UP DAMAGE AND REPAIR AS A HOLE	CLEAN UP DAMAGE AND REPAIR AS A HOLE	CLEAN UP DAMAGE AND REPAIR AS A HOLE
HOLES	2.0 INCHES (50 mm) MAX DIA NOT TO EXCEED 30% OF SMALLEST DIMENSION ACROSS HONEYCOMB PANEL AT THE DAMAGE LOCATION. FILL WITH BMS 5-28, TYPE 7 POTTING COMPOUND AND PATCH AS GIVEN IN SRM 51-70-03, PAR. 5.N. G	5.0 INCHES (125 mm) MAXIMUM DIA NOT TO EXCEED 50% OF SMALLEST DIMENSION ACROSS HONEYCOMB PANEL AT THE DAMAGE LOCATION. USE TWO EXTRA PLIES FOR EACH FACESHEET REPAIRED G	10.0 INCH (300 mm) MAXIMUM DIA NOT TO EXCEED 50% OF SMALLEST DIMENSION ACROSS HONEYCOMB PANEL AT THE DAMAGE LOCATION. USE TWO EXTRA PLIES FOR EACH SIDE	NO SIZE LIMIT
DELAMINATION	CUT OUT AND REPAIR AS A HOLE			
NICKS AND GOUGES	IF THERE IS NO FIBER DAMAGE OR DELAMINATION, FILL NICKS OR GOUGES AS GIVEN IN SRM 51-70-03 IF YOU FIND FIBER DAMAGE OR DELAMINATION, THEN REPAIR AS A HOLE			
DENTS	UP TO 2.0 INCHES (50 mm) DIA WITH NO FIBER DAMAGE OR DELAMINATION, FILL WITH BMS 5-28, TYPE 7 POTTING COMPOUND AND PATCH AS GIVEN IN SRM 51-70-03, PAR. 5.L. G OVER 2.0 INCHES (50 mm) DIA OR WITH FIBER DAMAGE OR DELAMINATION, REPAIR AS A HOLE			

REPAIR DATA FOR 250°F CURE LAMINATES
TABLE III

**Wing To Body Fairing Skin Repairs
Figure 201 (Sheet 7 of 12)**



**757-200
STRUCTURAL REPAIR MANUAL**

DAMAGE	INTERIM REPAIRS [C]	PERMANENT REPAIRS		
	WET LAYUP 150°F (66°C) CURE (SRM 51-70-03)	WET LAYUP 200°F (93°C) CURE (SRM 51-70-17)	250°F (121°C) CURE (SRM 51-70-05)	350°F (177°C) CURE (SRM 51-70-04)
CRACKS	UP TO 2.0 INCHES (50 mm) LONG, REPAIR WITH PATCH AS GIVEN IN SRM 51-70-03, PAR. 5.N. [G]	CLEAN UP DAMAGE AND REPAIR AS A HOLE.	CLEAN UP DAMAGE AND REPAIR AS A HOLE.	CLEAN UP DAMAGE AND REPAIR AS A HOLE.
HOLES	2.0 INCH (50 mm) MAXIMUM DIA NOT TO EXCEED 30% OF SMALLEST DIMENSION ACROSS HONEYCOMB PANEL AT THE DAMAGE LOCATION. FILL WITH BMS 5-28, TYPE 7 POTTING COMPOUND AND PATCH AS GIVEN IN SRM 51-70-03, PAR. 5.N. [G]	10.0 INCH (250 mm) MAXIMUM DIA NOT TO EXCEED 50% OF SMALLEST DIMENSION ACROSS HONEYCOMB PANEL AT THE DAMAGE LOCATION. USE TWO EXTRA PLIES FOR EACH SIDE. [G]	5.0 INCH (125 mm) MAXIMUM DIA NOT TO EXCEED 50% OF SMALLEST DIMENSION ACROSS HONEYCOMB PANEL AT THE DAMAGE LOCATION. USE TWO EXTRA PLIES FOR EACH SIDE.	NO SIZE LIMIT
DELAMINATION	CUT OUT AND REPAIR AS A HOLE.			
NICKS AND GOUGES	IF THERE IS NO FIBER DAMAGE OR DELAMINATION, FILL NICKS OR GOUGES AS GIVEN IN SRM 51-70-03. IF YOU FIND FIBER DAMAGE OR DELAMINATION, THEN REPAIR AS A HOLE.			
DENTS	UP TO 2.0 INCHES (50 mm) DIA WITH NO FIBER DAMAGE OR DELAMINATION, FILL WITH BMS 5-28, TYPE 7 POTTING COMPOUND AND PATCH AS GIVEN IN SRM 51-70-03, PAR. 5.L. [G] OVER 2.0 INCHES (50 mm) DIA OR WITH FIBER DAMAGE OR DELAMINATION, REPAIR AS A HOLE.			

REPAIR DATA FOR 350°F CURE LAMINATES
TABLE IV

**Wing To Body Fairing Skin Repairs
Figure 201 (Sheet 8 of 12)**



757-200

STRUCTURAL REPAIR MANUAL

DAMAGE	INTERIM REPAIRS C	PERMANENT REPAIRS	
	ROOM TEMP (SRM 51-70-03)	WET LAYUP – 200°F (93°C) CURE (SRM 51-70-17)	250°F (121°C) CURE (SRM 51-70-05)
HOLES AND PUNCTURES	REPAIR DAMAGE TO FASTENER HOLES AS GIVEN IN SRM 51-70-03, PAR. 5.K. FOR ALL OTHER DAMAGE UP TO 15% OF CROSS-SECTIONAL AREA THRU THE EDGE BAND OR 10% OF THE EDGE BAND LENGTH FOR EACH AFFECTED SIDE, REPAIR AS GIVEN IN SRM 51-70-03, PAR. 5.G.	REPAIR DAMAGE TO FASTENER HOLES AS GIVEN IN SRM 51-70-17, PAR. 4.K. FOR ALL OTHER DAMAGE, REPAIR AS GIVEN IN SRM 51-70-17, PAR. 4.G.	REPAIR DAMAGE TO FASTENER HOLES AS GIVEN IN SRM 51-70-05, PAR. 5.K. FOR ALL OTHER DAMAGE, REPAIR AS GIVEN IN SRM 51-70-05, PAR. 5.G.
DELAMINATION	IF DELAMINATION FROM PANEL EDGE IS NO LESS THAN 2D FROM ANY FASTENER HOLE, REPAIR AS GIVEN IN SRM 51-70-03, PAR. 5.A.(2). ANY OTHER DELAMINATION MUST BE CUT OUT AND REPAIRED AS A HOLE	CUT OUT AND REPAIR AS A HOLE	CUT OUT AND REPAIR AS A HOLE
EDGE EROSION	-----	FOR DAMAGE NOT LARGER THAN 35% OF EDGE BAND THICKNESS, REPAIR AS GIVEN IN SRM 51-70-03, PAR. 5.O. FOR LARGER DAMAGE, REPAIR AS GIVEN IN: SRM 51-70-17, PAR. 4.G.	SRM 51-70-05, PAR. 5.G.
CRACKS	REPAIR AS A HOLE		
NICKS AND GOUGES	IF THERE IS NO FIBER DAMAGE OR DELAMINATION, FILL NICKS OR GOUGES AS GIVEN IN SRM 51-70-03 IF YOU FIND FIBER DAMAGE OR DELAMINATION, THEN REPAIR AS A HOLE OR DELAMINATION, WHICHEVER IS APPLICABLE		
DENTS	IF THERE IS NO FIBER DAMAGE OR DELAMINATION, FILL DENTS AS GIVEN IN SRM 51-70-03 IF FIBER DAMAGE OR DELAMINATION EXISTS, REPAIR AS A HOLE OR DELAMINATION, WHICHEVER IS APPLICABLE		

REPAIR DATA FOR EDGE BANDS OF 250°F HONEYCOMB PANELS
TABLE V

Wing To Body Fairing Skin Repairs
Figure 201 (Sheet 9 of 12)

D634N201

53-00-70

REPAIR 1
Page 209
Jan 20/2005

STRUCTURAL REPAIR MANUAL

DAMAGE	INTERIM REPAIRS C	PERMANENT REPAIRS	
	150°F (66°C) CURE (SRM 51-70-03)	WET LAYUP 200°F (93°C) CURE (SRM 51-70-17)	350°F (177°C) CURE (SRM 51-70-04)
HOLES AND PUNCTURES	REPAIR DAMAGE TO FASTENER HOLES AS GIVEN IN SRM 51-70-03, PAR. 5.K. FOR ALL OTHER DAMAGE UP TO 15% OF CROSS-SECTIONAL AREA THRU THE EDGE BAND OR 10% OF THE EDGE BAND LENGTH PER AFFECTED SIDE, REPAIR AS GIVEN IN SRM 51-70-03, PAR. 5.G.	REPAIR DAMAGE TO FASTENER HOLES AS GIVEN IN SRM 51-70-17, PAR. 4.K. FOR ALL OTHER DAMAGE, REPAIR AS GIVEN IN SRM 51-70-17, PAR. 4.G.	REPAIR DAMAGE TO FASTENER HOLES AS GIVEN IN SRM 51-70-04, PAR. 5.K. FOR ALL OTHER DAMAGE, REPAIR AS GIVEN IN SRM 51-70-04, PAR. 5.G.
DELAMINATION	IF DELAMINATION FROM PANEL EDGE IS NO LESS THAN 2D FROM ANY FASTENER HOLE, REPAIR AS GIVEN IN SRM 51-70-03, PAR. 5.A.(2). ANY OTHER DELAMINATION MUST BE CUT OUT AND REPAIRED AS A HOLE.	CUT OUT AND REPAIR AS A HOLE.	CUT OUT AND REPAIR AS A HOLE.
EDGE EROSION	-----	FOR DAMAGE NOT LARGER THAN 35% OF EDGE BAND THICKNESS, REPAIR AS GIVEN IN SRM 51-70-03, PAR. 5.O. FOR LARGER DAMAGE, REPAIR AS GIVEN IN : SRM 51-70-17, PAR. 4.G. SRM 51-70-04, PAR. 5.G.	
CRACKS	REPAIR AS A HOLE.		
NICKS AND GOUGES	IF THERE IS NO FIBER DAMAGE OR DELAMINATION, FILL NICKS OR GOUGES AS GIVEN IN SRM 51-70-03. IF YOU FIND FIBER DAMAGE OR DELAMINATION, THEN REPAIR AS A HOLE OR DELAMINATION, WHICHEVER IS APPLICABLE.		
DENTS	IF THERE IS NO FIBER DAMAGE OR DELAMINATION, FILL DENTS AS GIVEN IN SRM 51-70-03. IF YOU FIND FIBER DAMAGE OR DELAMINATION, THEN REPAIR AS A HOLE OR DELAMINATION, WHICHEVER IS APPLICABLE.		

REPAIR DATA FOR EDGE BANDS OF 350°F HONEYCOMB PANELS
TABLE VI

Wing To Body Fairing Skin Repairs
Figure 201 (Sheet 10 of 12)

STRUCTURAL REPAIR MANUAL

DAMAGE	INTERIM REPAIRS C	PERMANENT REPAIRS	
	ROOM TEMP (SRM 51-70-03)	WET LAYUP – 200°F (93°C) CURE (SRM 51-70-17)	250°F (121°C) CURE (SRM 51-70-05)
HOLES AND PUNCTURES	REPAIR DAMAGE TO FASTENER HOLES AS GIVEN IN SRM 51-70-03, PAR. 5.K. FOR ALL OTHER DAMAGE UP TO 15% OF CROSS-SECTIONAL AREA THRU THE EDGE BAND OR 10% OF THE EDGE BAND LENGTH FOR EACH AFFECTED SIDE, REPAIR AS GIVEN IN SRM 51-70-03, PAR. 5.G.	REPAIR DAMAGE TO FASTENER HOLES AS GIVEN IN SRM 51-70-17, PAR. 4.K. FOR ALL OTHER DAMAGE, REPAIR AS GIVEN IN SRM 51-70-17, PAR. 4.G.	REPAIR DAMAGE TO FASTENER HOLES AS GIVEN IN SRM 51-70-05, PAR. 5.K. FOR ALL OTHER DAMAGE, REPAIR AS GIVEN IN SRM 51-70-05, PAR. 5.G.
DELAMINATION	IF DELAMINATION FROM PANEL EDGE IS NO LESS THAN 2D FROM ANY FASTENER HOLE, REPAIR AS GIVEN IN SRM 51-70-03, PAR. 5.A.(2). ANY OTHER DELAMINATION MUST BE CUT OUT AND REPAIRED AS A HOLE	CUT OUT AND REPAIR AS A HOLE	CUT OUT AND REPAIR AS A HOLE
EDGE EROSION	-----	FOR DAMAGE NOT LARGER THAN 35% OF EDGE BAND THICKNESS, REPAIR AS GIVEN IN SRM 51-70-03, PAR. 5.O. FOR LARGER DAMAGE, REPAIR AS GIVEN IN: SRM 51-70-17, PAR. 4.G.	SRM 51-70-05, PAR. 5.G.
CRACKS	REPAIR AS A HOLE		
NICKS AND GOUGES	IF THERE IS NO FIBER DAMAGE OR DELAMINATION, FILL NICKS OR GOUGES AS GIVEN IN SRM 51-70-03 IF YOU FIND FIBER DAMAGE OR DELAMINATION, THEN REPAIR AS A HOLE OR DELAMINATION, WHICHEVER IS APPLICABLE		
DENTS	IF THERE IS NO FIBER DAMAGE OR DELAMINATION, FILL DENTS AS GIVEN IN SRM 51-70-03 IF YOU FIND FIBER DAMAGE OR DELAMINATION, THEN REPAIR AS A HOLE OR DELAMINATION, WHICHEVER IS APPLICABLE		

REPAIR DATA FOR EDGE BANDS OF 250°F (121°C) CURE LAMINATES
TABLE VII

**Wing To Body Fairing Skin Repairs
Figure 201 (Sheet 11 of 12)**



757-200

STRUCTURAL REPAIR MANUAL

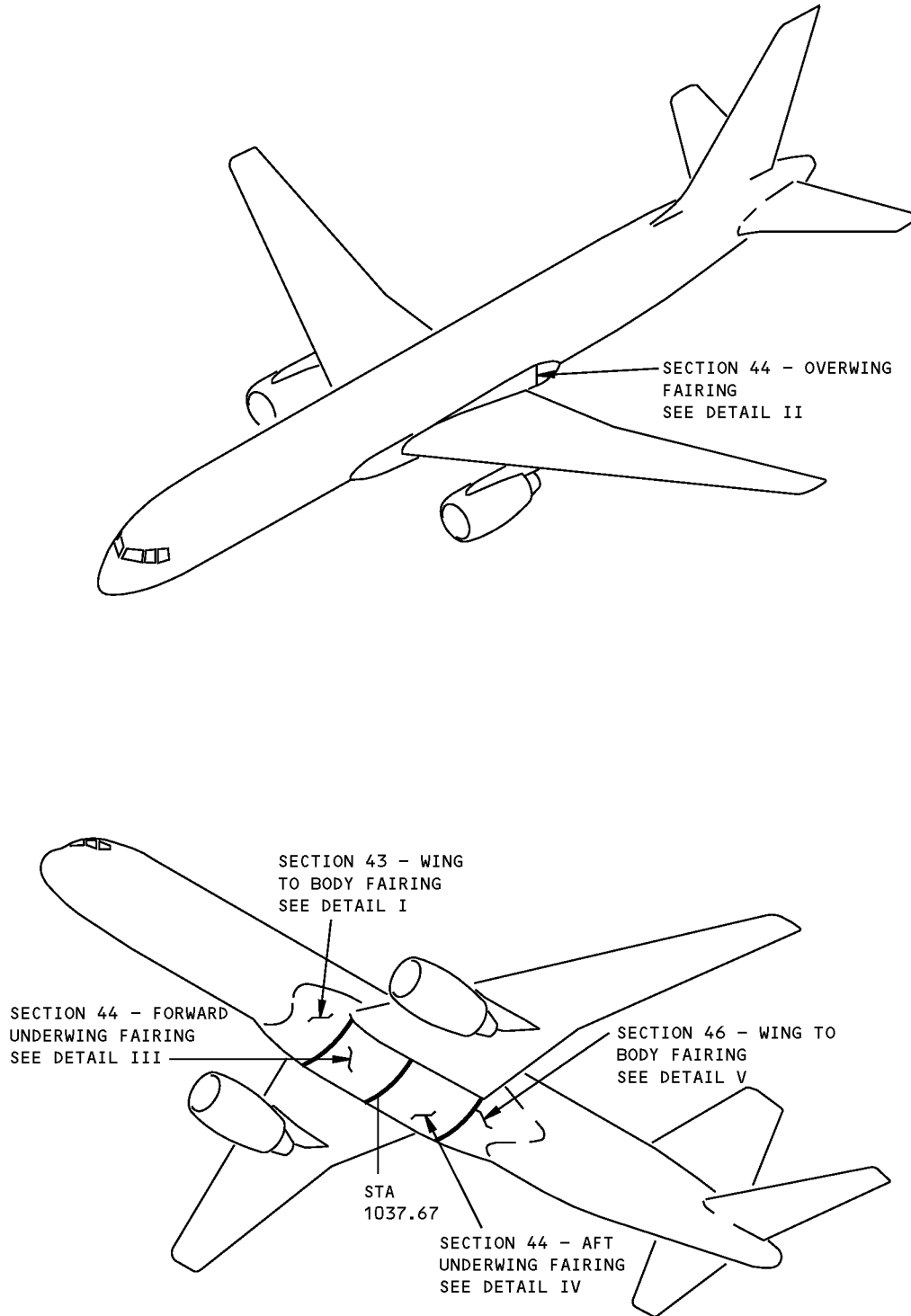
DAMAGE	INTERIM REPAIRS C	PERMANENT REPAIRS	
	150°F (66°C) CURE (SRM 51-70-03)	WET LAYUP 200°F (93°C) CURE (SRM 51-70-17)	350°F (177°C) CURE (SRM 51-70-04)
HOLES AND PUNCTURES	REPAIR DAMAGE TO FASTENER HOLES AS GIVEN IN SRM 51-70-03, PAR. 5.K. FOR ALL OTHER DAMAGE UP TO 15% OF CROSS-SECTIONAL AREA THRU THE EDGE BAND OR 10% OF THE EDGE BAND LENGTH AS GIVEN IN AFFECTED SIDE, REPAIR AS GIVEN IN SRM 51-70-03, PAR. 5.G.	REPAIR DAMAGE TO FASTENER HOLES AS GIVEN IN SRM 51-70-17, PAR. 4.K. FOR ALL OTHER DAMAGE, REPAIR AS GIVEN IN SRM 51-70-17, PAR. 4.G.	REPAIR DAMAGE TO FASTENER HOLES AS GIVEN IN SRM 51-70-04, PAR. 5.K. FOR ALL OTHER DAMAGE, REPAIR AS GIVEN IN SRM 51-70-04, PAR. 5.G.
DELAMINATION	IF DELAMINATION FROM PANEL EDGE IS NO LESS THAN 2D FROM ANY FASTENER HOLE, REPAIR AS GIVEN IN SRM 51-70-03, PAR. 5.A.(2). ANY OTHER DELAMINATION MUST BE CUT OUT AND REPAIRED AS A HOLE.	CUT OUT AND REPAIR AS A HOLE.	CUT OUT AND REPAIR AS A HOLE.
EDGE EROSION	-----	FOR DAMAGE NOT LARGER THAN 35% OF EDGE BAND THICKNESS, REPAIR AS GIVEN IN SRM 51-70-03, PAR. 5.O. FOR LARGER DAMAGE, REPAIR AS GIVEN IN: SRM 51-70-17, PAR. 4.G.	SRM 51-70-04, PAR. 5.G.
CRACKS	REPAIR AS A HOLE.		
NICKS AND GOUGES	IF THERE IS NO FIBER DAMAGE OR DELAMINATION, FILL NICKS OR GOUGES AS GIVEN IN SRM 51-70-03. IF YOU FIND FIBER DAMAGE OR DELAMINATION, THEN REPAIR AS A HOLE OR DELAMINATION, WHICHEVER IS APPLICABLE.		
DENTS	IF THERE IS NO FIBER DAMAGE OR DELAMINATION, FILL DENTS AS GIVEN IN SRM 51-70-03. IF YOU FIND FIBER DAMAGE OR DELAMINATION, THEN REPAIR AS A HOLE OR DELAMINATION, WHICHEVER IS APPLICABLE.		

REPAIR DATA FOR EDGE BANDS OF 350°F (177° C) CURE LAMINATES
TABLE VIII

Wing To Body Fairing Skin Repairs
Figure 201 (Sheet 12 of 12)

757-200
STRUCTURAL REPAIR MANUAL

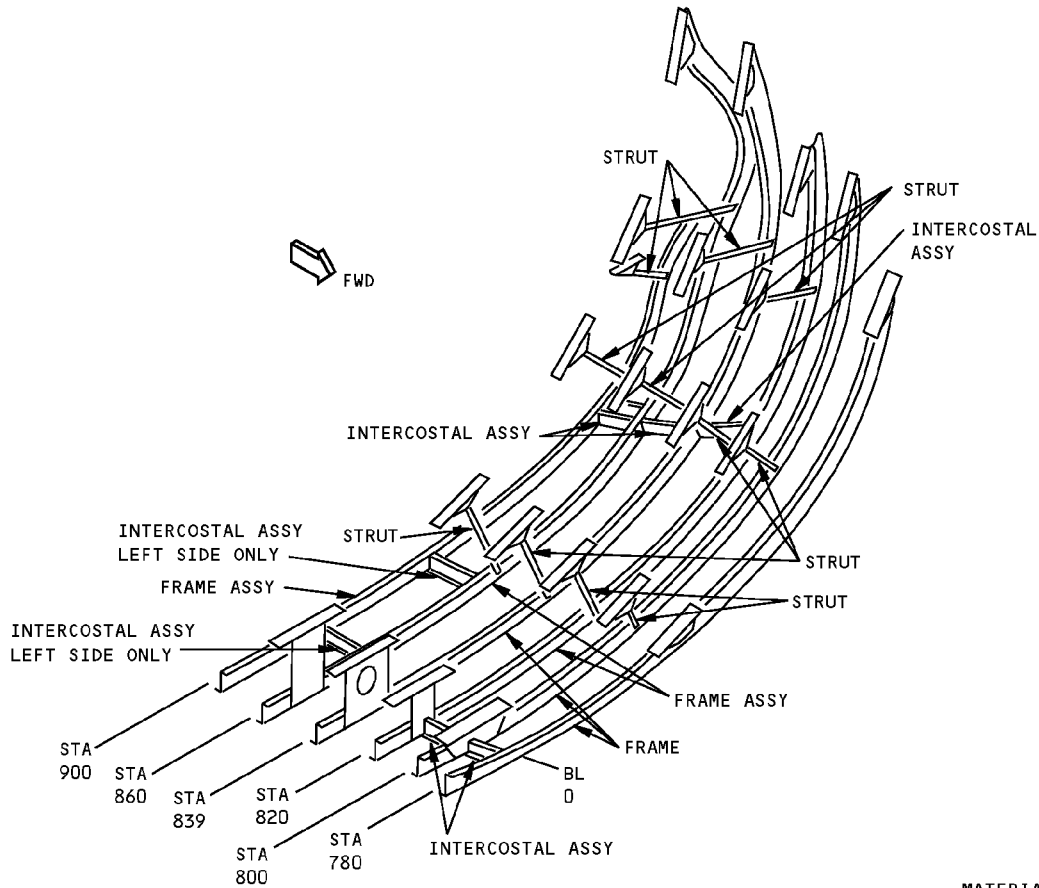
ALLOWABLE DAMAGE 1 - WING TO BODY FAIRING STRUCTURE



Wing to Body Fairing Structure Allowable Damage
Figure 101 (Sheet 1 of 10)

**757-200
STRUCTURAL REPAIR MANUAL**

REF DWG
149N7101



MATERIAL:
ALUMINUM

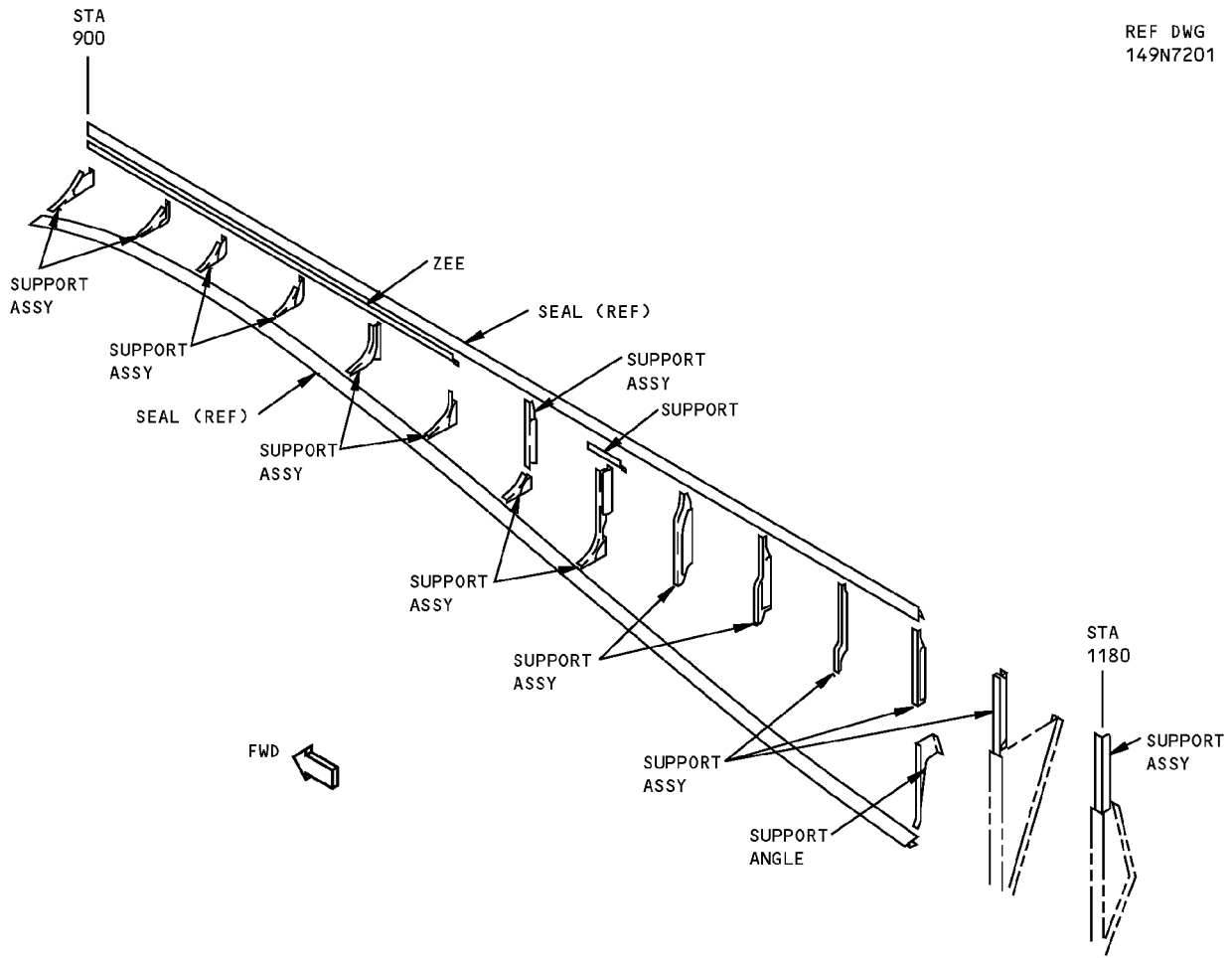
LEFT SIDE SHOWN
RIGHT SIDE OPPOSITE EXCEPT AS NOTED
SECTION 43 - WING TO BODY FAIRING
DETAIL I

DESCRIPTION	CRACKS	NICKS, GOUGES AND CORROSION	DENTS	HOLES AND PUNCTURES
FRAME ASSY				
FRAME	B	E	SEE DETAIL VIII	H
OUTBOARD CHORD	A	D	NOT ALLOWED	H
INTERCOSTAL ASSY				
CHORD	A	D	NOT ALLOWED	NOT ALLOWED
WEB	C	F	SEE DETAIL VIII	H
FRAME	B	E	SEE DETAIL VIII	H
STRUT	A	D	NOT ALLOWED	NOT ALLOWED

**Wing to Body Fairing Structure Allowable Damage
Figure 101 (Sheet 2 of 10)**

**757-200
STRUCTURAL REPAIR MANUAL**

REF DWG
149N7201



LEFT SIDE SHOWN
RIGHT SIDE OPPOSITE

MATERIAL:
ALUMINUM

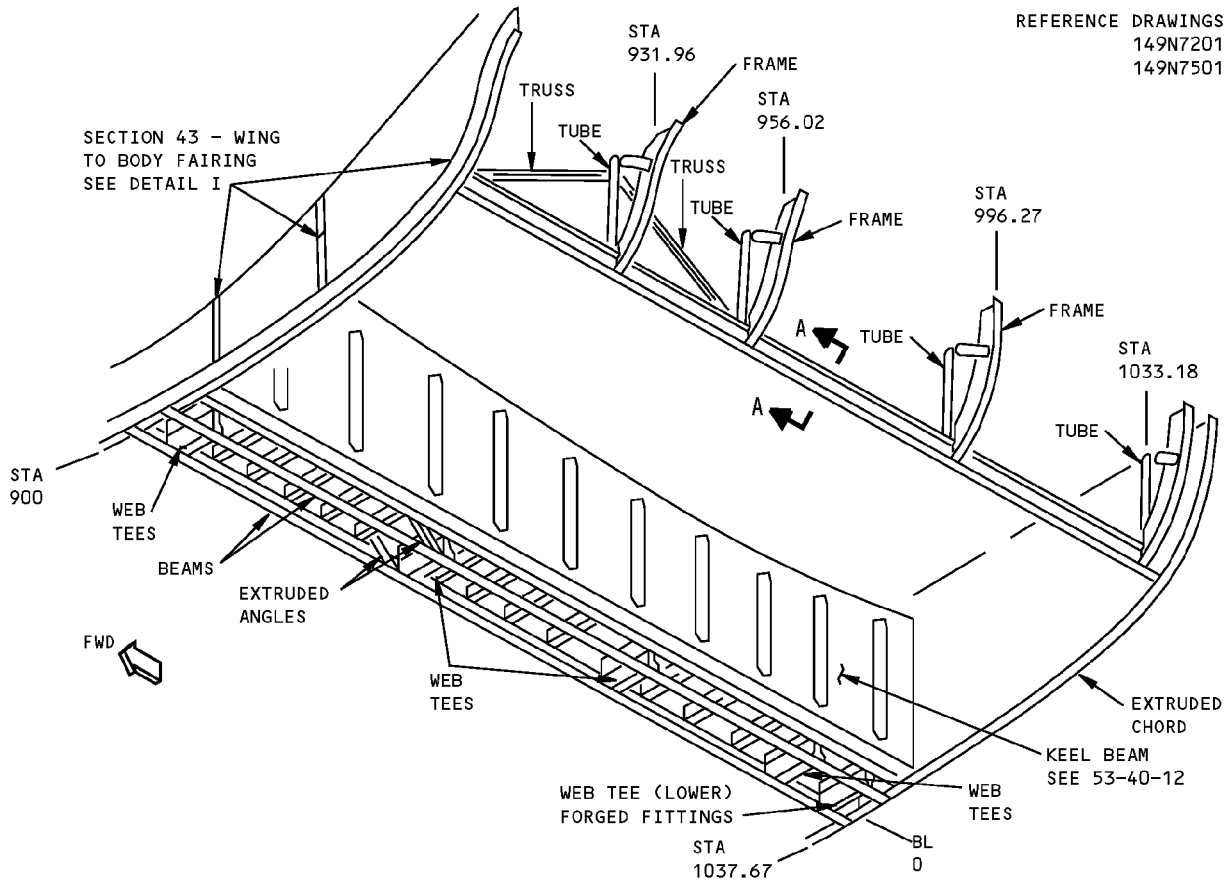
**SECTION 44 - OVERWING FAIRING
DETAIL II**

DESCRIPTION	CRACKS	NICKS, GOUGES AND CORROSION	DENTS	HOLES AND PUNCTURES
ZEE	B	E	SEE DETAIL VIII	H
SUPPORT ANGLE	B	E	SEE DETAIL VIII	H
SUPPORT ASSY				
SUPPORT	A	D	NOT ALLOWED	H
ANGLE	B	E	NOT ALLOWED	H

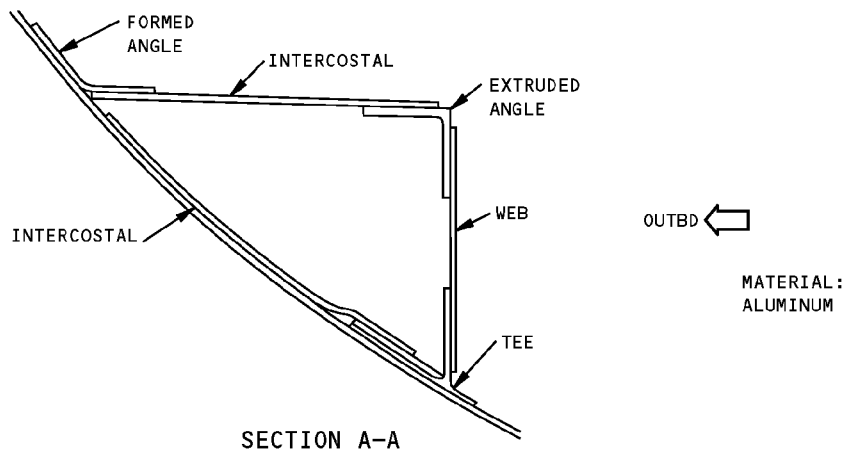
**Wing to Body Fairing Structure Allowable Damage
Figure 101 (Sheet 3 of 10)**

**757-200
STRUCTURAL REPAIR MANUAL**

REFERENCE DRAWINGS
149N7201
149N7501



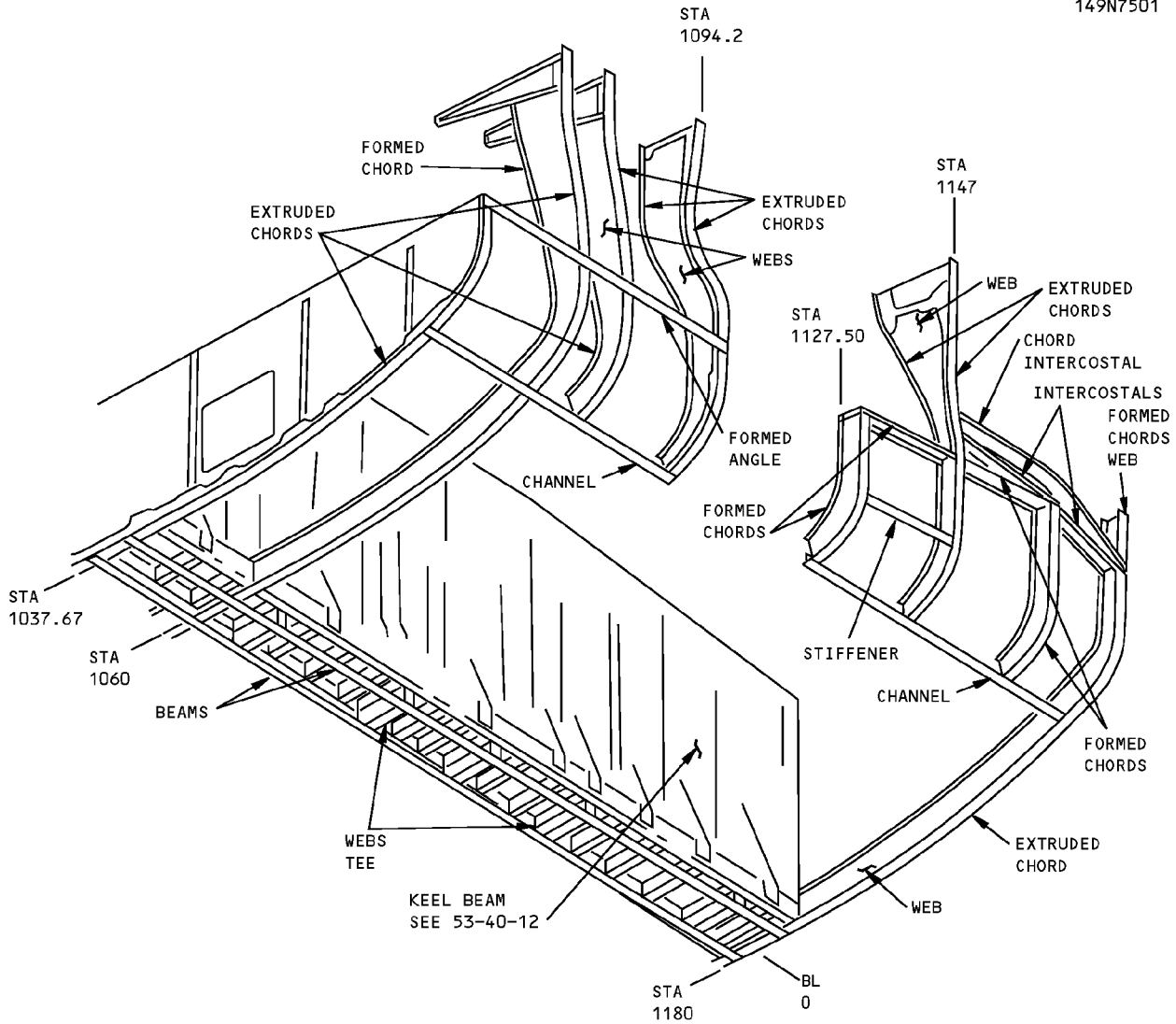
LEFT SIDE IS SHOWN, RIGHT SIDE IS OPPOSITE
SECTION 44 - FORWARD UNDERWING FAIRING
DETAIL III



**Wing to Body Fairing Structure Allowable Damage
Figure 101 (Sheet 4 of 10)**

**757-200
STRUCTURAL REPAIR MANUAL**

REF DWG
149N7201
149N7501



LEFT SIDE SHOWN
RIGHT SIDE OPPOSITE

MATERIAL:
ALUMINUM

**SECTION 44 - AFT UNDERWING FAIRING
DETAIL IV**

**Wing to Body Fairing Structure Allowable Damage
Figure 101 (Sheet 5 of 10)**



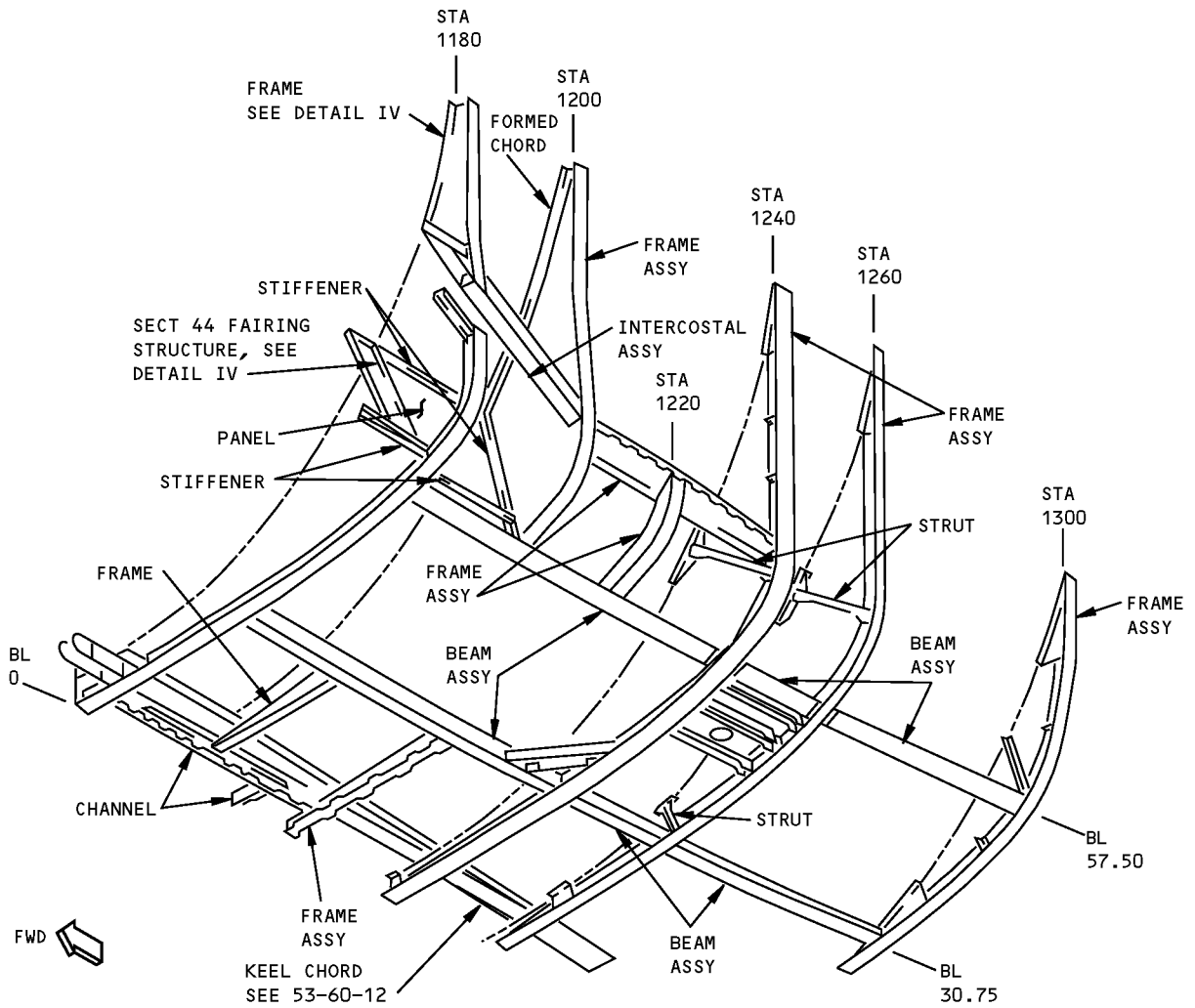
**757-200
STRUCTURAL REPAIR MANUAL**

DESCRIPTION	CRACKS	NICKS, GOUGES AND CORROSION	DENTS	HOLES AND PUNCTURES
CHORDS FORMED	B	E	SEE DETAIL VIII	H
EXTRUDED	A	D	NOT ALLOWED	NOT ALLOWED
ANGLES FORMED	B	E	SEE DETAIL VIII	H
EXTRUDED	A	D	NOT ALLOWED	NOT ALLOWED
BEAM	A	D	NOT ALLOWED	H
TEE	A	D	NOT ALLOWED	NOT ALLOWED
TRUSS	A	D	NOT ALLOWED	NOT ALLOWED
FRAME	B	E	SEE DETAIL VIII	H
STIFFENER	B	E	SEE DETAIL VIII	H
CHANNEL	C	F	SEE DETAIL VIII	H
INTERCOSTAL	C	F	SEE DETAIL VIII	H
WEB	C	F	SEE DETAIL VIII	H
FORGED FITTING	A	G	NOT ALLOWED	NOT ALLOWED
TUBE	NOT ALLOWED	SEE DETAIL VII	NOT ALLOWED	NOT ALLOWED

ALLOWABLE DAMAGE FOR DETAILS III AND IV

**Wing to Body Fairing Structure Allowable Damage
Figure 101 (Sheet 6 of 10)**

**757-200
STRUCTURAL REPAIR MANUAL**



LEFT SIDE SHOWN
RIGHT SIDE OPPOSITE
SECTION 46 - WING TO BODY FAIRING
DETAIL V

MATERIAL:
ALUMINUM

**Wing to Body Fairing Structure Allowable Damage
Figure 101 (Sheet 7 of 10)**

ALLOWABLE DAMAGE 1

53-00-71

Page 107
Jan 20/2005

D634N201



**757-200
STRUCTURAL REPAIR MANUAL**

DESCRIPTION	CRACKS	NICKS, GOUGES AND CORROSION	DENTS	HOLES AND PUNCTURES
BEAM ASSY				
WEB	C	F	SEE DETAIL VIII	H
LOWER CHORD	A	D	NOT ALLOWED	NOT ALLOWED
FRAME ASSY				
WEB	C	F	SEE DETAIL VIII	H
OUTER CHORD	A	D	NOT ALLOWED	NOT ALLOWED
INTERCOSTAL ASSY				
WEB	C	F	SEE DETAIL VIII	H
CHORD	A	D	NOT ALLOWED	NOT ALLOWED
FRAME	B	E	SEE DETAIL VIII	H
FORMED CHORD	B	E	SEE DETAIL VIII	H
STIFFENER	A	D	NOT ALLOWED	H
CHANNEL	C	F	SEE DETAIL VIII	H
STRUT	A	D	NOT ALLOWED	NOT ALLOWED
PANEL	C	F	SEE DETAIL VIII	H

ALLOWABLE DAMAGE FOR DETAIL V

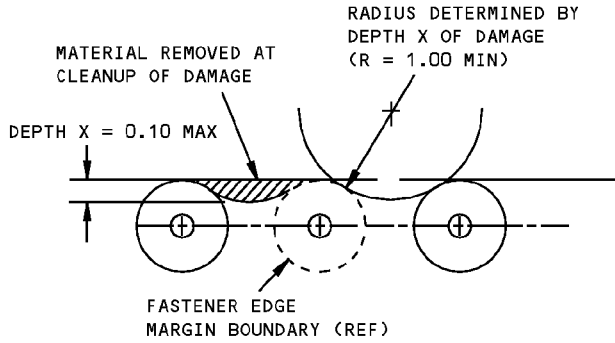
NOTES

- REFINISH REWORKED AREAS PER 51-20 OF THE MAINTENANCE MANUAL
- A** CRACKS NOT ALLOWED EXCEPT FOR EDGE CRACKS WHICH MUST BE REMOVED PER DETAILS VI AND XII
- B** CRACKS NOT ALLOWED EXCEPT FOR EDGE CRACKS WHICH MUST BE REMOVED PER DETAILS VI AND XI
- C** CRACKS NOT ALLOWED EXCEPT FOR EDGE CRACKS WHICH MUST BE REMOVED PER DETAILS VI AND X
- D** REMOVE DAMAGE PER DETAILS VI, VII, IX, AND XII

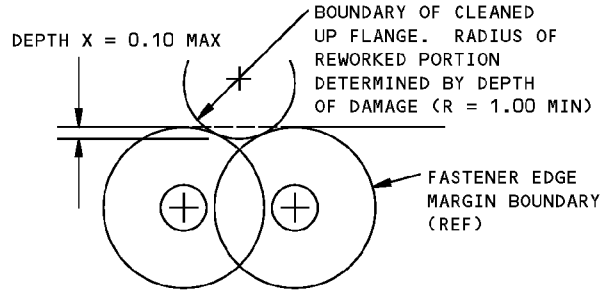
- E** REMOVE DAMAGE PER DETAILS VI, VII, IX AND XI
- F** REMOVE DAMAGE PER DETAILS VI, VII, IX AND X
- G** FOR EDGE DAMAGE SEE DETAIL XII. FOR LUG DAMAGE, SEE DETAIL XIII. FOR OTHER DAMAGE, SEE DETAIL VII. DAMAGE NOT ALLOWED IN VICINITY OF BUSHINGS
- H** CLEAN OUT DAMAGE UP TO 0.25 MAX DIA AND NOT CLOSER THAN 1.0 INCH TO FASTENER HOLE, MATERIAL EDGE, OR OTHER DAMAGE. FILL HOLE WITH A 2117-T3 OR T4 ALUMINUM RIVET INSTALLED WET WITH BMS5-95 SEALANT. ALL OTHER HOLES TO BE REPAIRED

**Wing to Body Fairing Structure Allowable Damage
Figure 101 (Sheet 8 of 10)**

STRUCTURAL REPAIR MANUAL

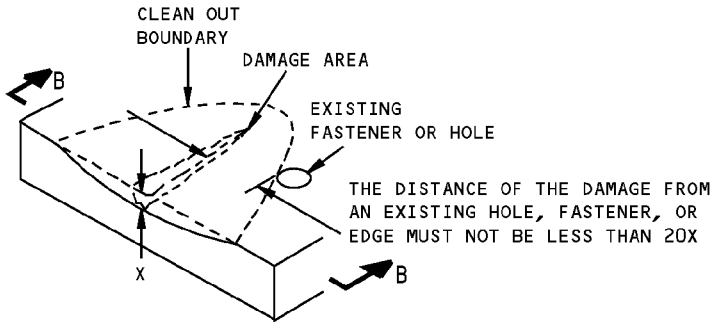


DAMAGE CLEAN UP OF EDGES WHERE FASTENER EDGE MARGINS DO NOT OVERLAP

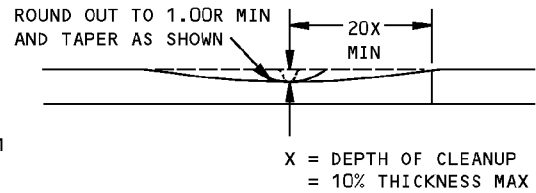


DAMAGE CLEANUP OF EDGES WHERE FASTENER EDGE MARGINS OVERLAP

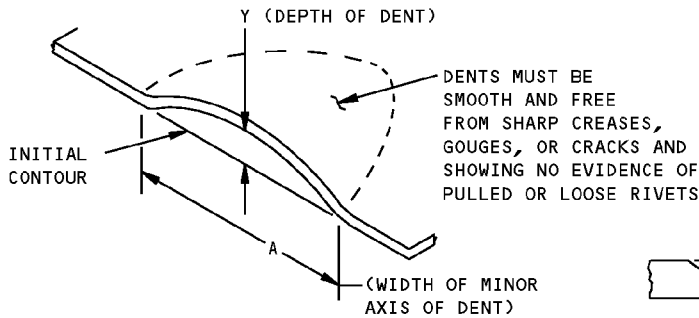
DETAIL VI



REMOVAL OF NICK, GOUGE AND SCRATCH DAMAGE ON A SURFACE
DETAIL VII

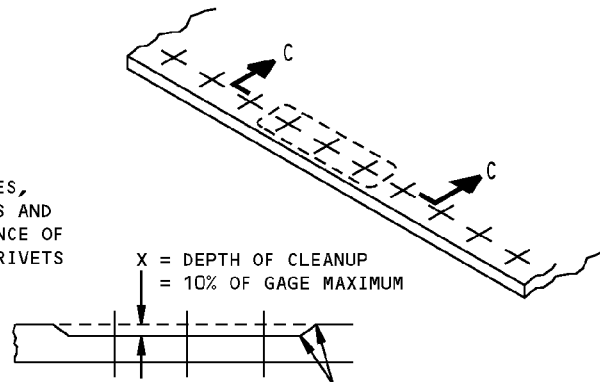


SECTION B-B



$\frac{A}{Y}$ MUST NOT BE LESS THAN 30

ALLOWABLE DAMAGE FOR DENT
DETAIL VIII

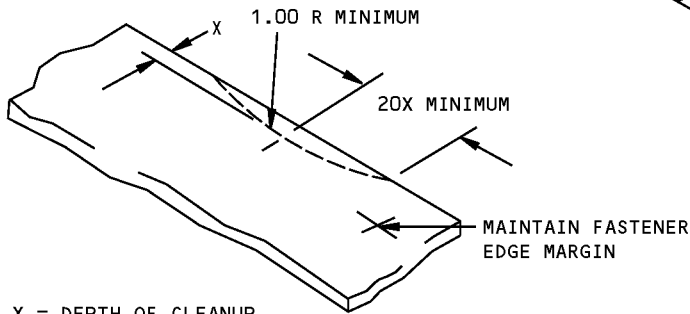


SMOOTH BLEND-OUT RADIUS 0.50 INCH MINIMUM.
CORROSION CLEANUP AROUND ANY THREE FASTENERS
IN TEN IS PERMITTED TO MAXIMUM DEPTH

SECTION C-C
CORROSION CLEANUP
DETAIL IX

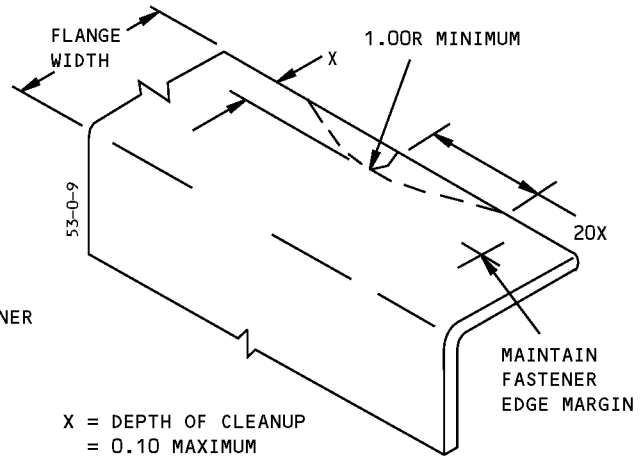
**Wing to Body Fairing Structure Allowable Damage
Figure 101 (Sheet 9 of 10)**

**757-200
STRUCTURAL REPAIR MANUAL**



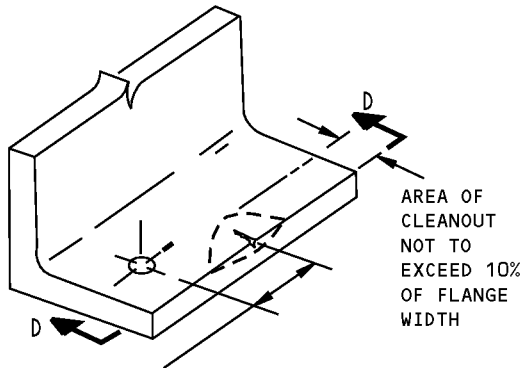
X = DEPTH OF CLEANUP
= 0.10 MAXIMUM

**REMOVAL OF NICK OR CRACK
DAMAGE ON AN EDGE
DETAIL X**

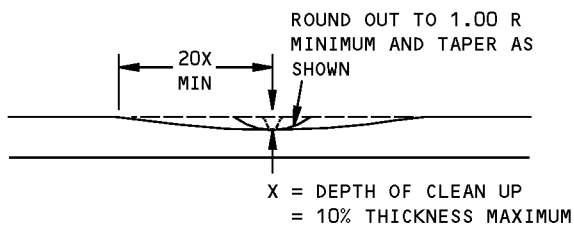


X = DEPTH OF CLEANUP
= 0.10 MAXIMUM

**REMOVAL OF NICK OR CRACK
DAMAGE ON AN EDGE
DETAIL XI**

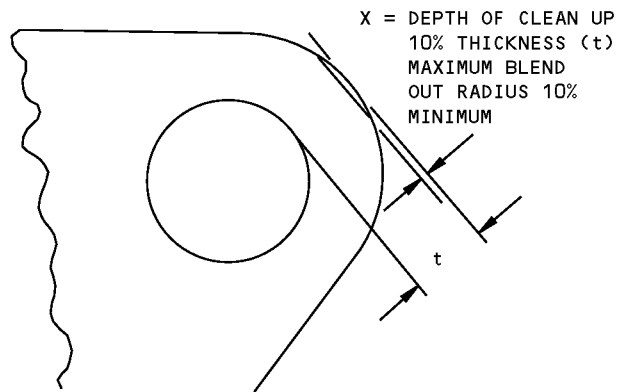


THE DISTANCE OF THE DAMAGE FROM
AN EXISTING HOLE OR FASTENER
MUST NOT BE LESS THAN 20X



SECTION D-D

**REMOVAL OF NICK OR CRACK
DAMAGE ON AN EDGE
DETAIL XII**



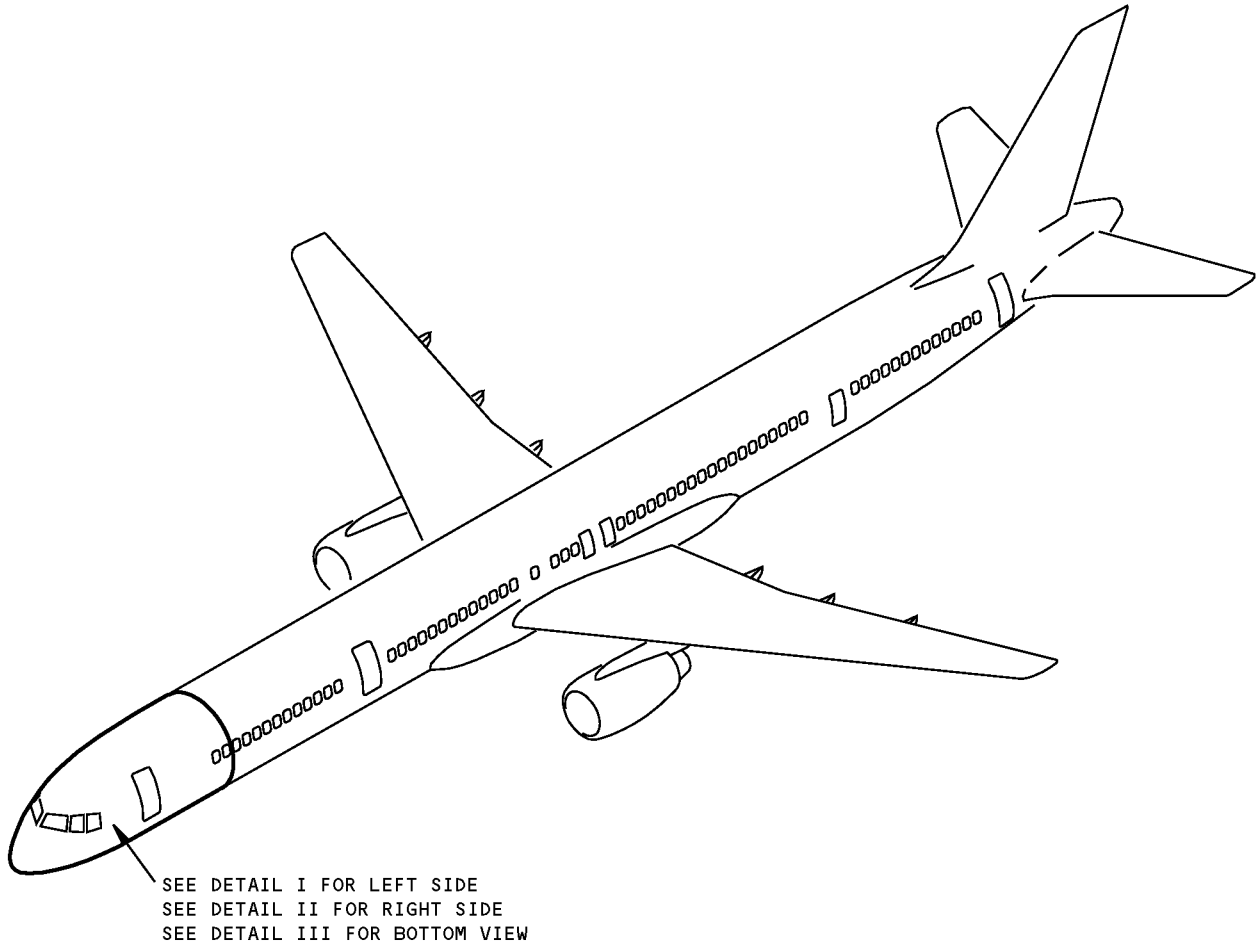
**DAMAGE CLEAN UP FOR EDGES OF LUG
DETAIL XIII**

**Wing to Body Fairing Structure Allowable Damage
Figure 101 (Sheet 10 of 10)**



757-200
STRUCTURAL REPAIR MANUAL

IDENTIFICATION 1 - SECTION 41 - SKINS



Section 41 Skin Identification
Figure 1 (Sheet 1 of 3)

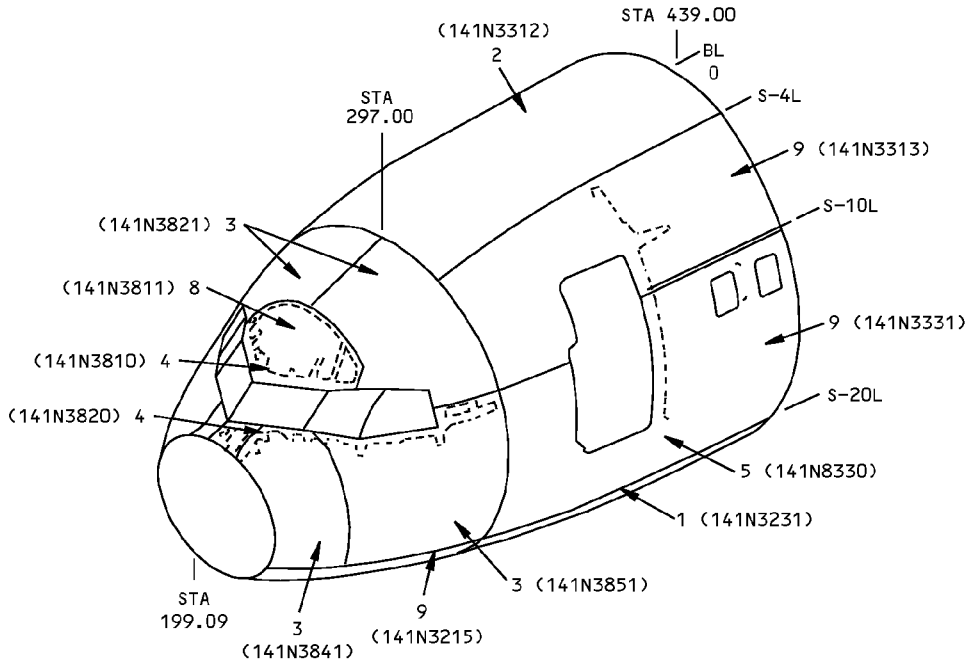
D634N201

53-10-01

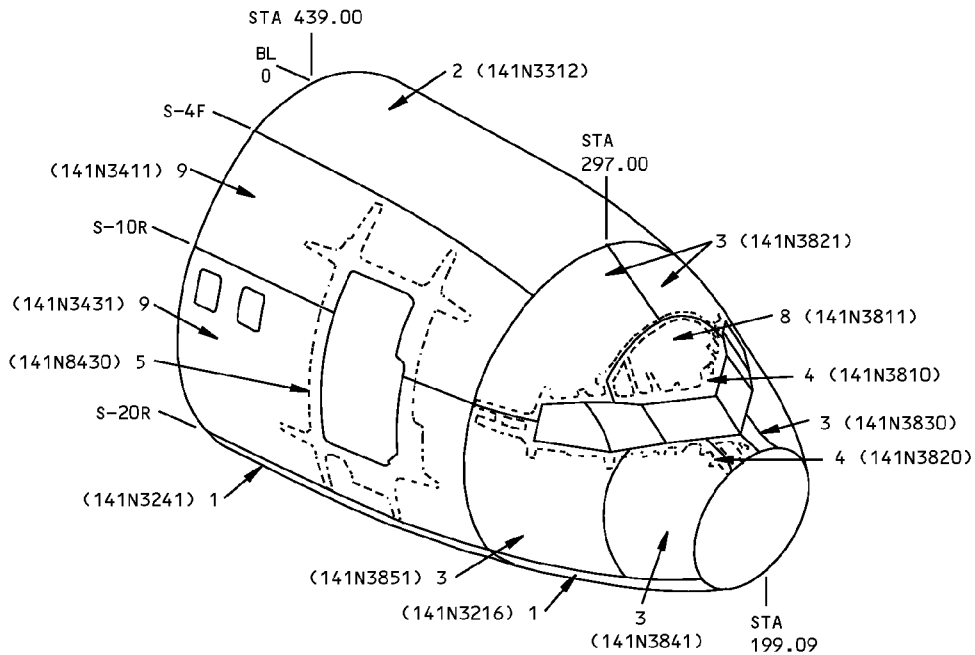
IDENTIFICATION 1
Page 1
Jan 20/2005

**757-200
STRUCTURAL REPAIR MANUAL**

REF DWG
140N1520



**LEFT SIDE
DETAIL I**



**RIGHT SIDE
DETAIL II**

**Section 41 Skin Identification
Figure 1 (Sheet 2 of 3)**

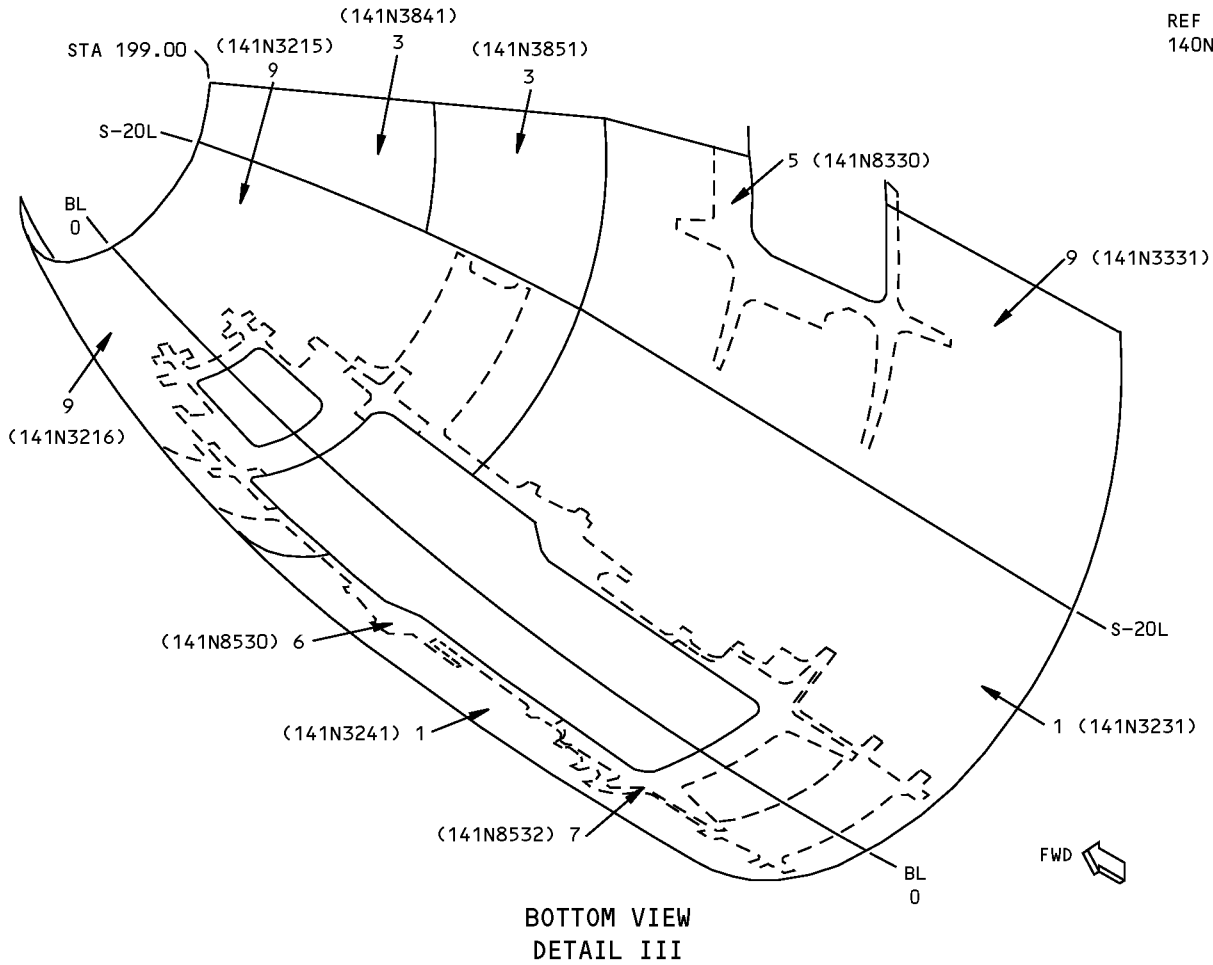
IDENTIFICATION 1
Page 2
Jan 20/2005

53-10-01

D634N201

**757-200
STRUCTURAL REPAIR MANUAL**

REF DWG
140N1520



ITEM	DESCRIPTION	GAGE	MATERIAL	EFFECTIVITY
1	SKIN	0.125	CLAD 2024-T3 (CHEM-MILLED TO 0.040 MIN)	
2	SKIN	0.063	CLAD 2024-T3 (CHEM-MILLED TO 0.040 MIN)	
3	SKIN	0.090	CLAD 2024-T3 (CHEM-MILLED TO 0.040 MIN)	
4	DOUBLER	0.063	TI-6AL-4V	
5	DOUBLER	0.100	2024-T3	
6	DOUBLER	0.080	2024-T3	
7	TRIPLER	0.080	2024-T3	
8	SKIN	0.160	CLAD 2024-T3 (CHEM-MILLED TO 0.140 MIN)	
9	SKIN	0.100	CLAD 2024-T3 (CHEM-MILLED TO 0.040 MIN)	

LIST OF MATERIALS FOR DETAILS I,II AND III

**Section 41 Skin Identification
Figure 1 (Sheet 3 of 3)**

IDENTIFICATION 1
Page 3
Jan 20/2005

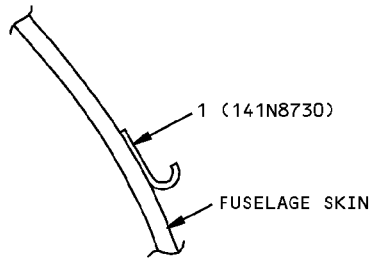
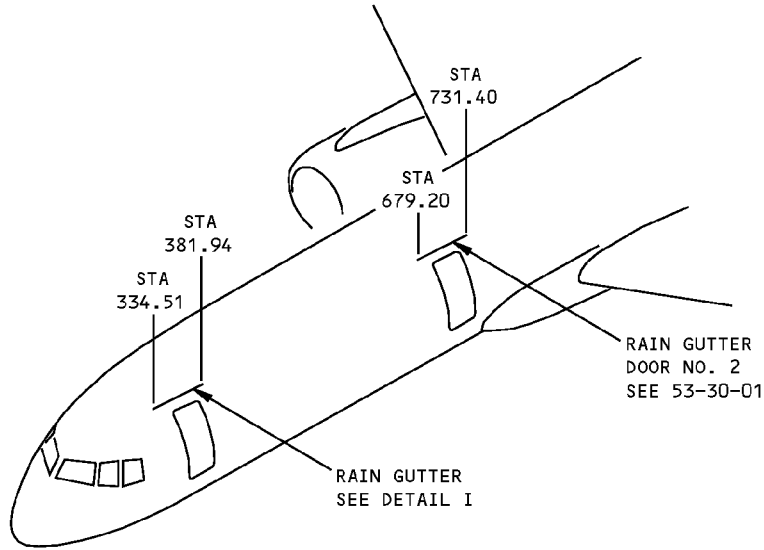
53-10-01

D634N201

**757-200
STRUCTURAL REPAIR MANUAL**

IDENTIFICATION 2 - SECTION 41 - RAIN GUTTER

REF DWG
141N3311



SECTION THRU RAIN GUTTER
DETAIL I

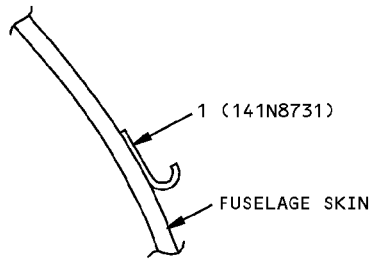
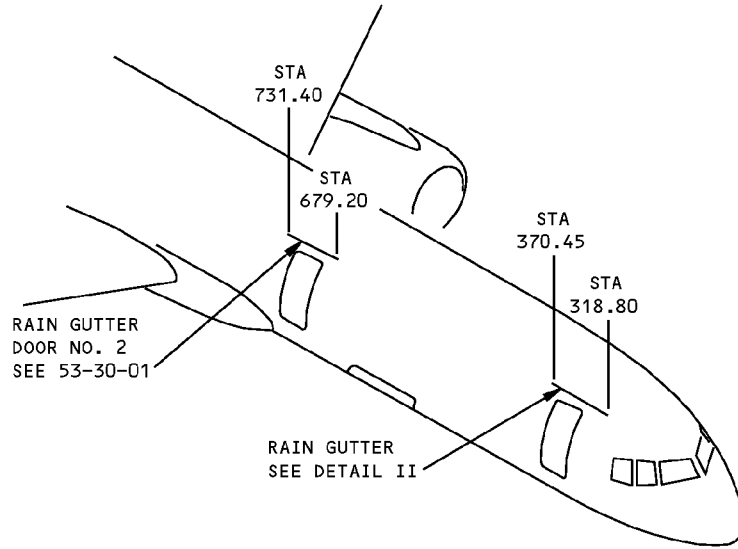
ITEM	DESCRIPTION	GAGE	MATERIAL	EFFECTIVITY
1	GUTTER		BAC1498-356 CLAD 2024-T3	

LIST OF MATERIALS FOR DETAIL I

**Section 41 - Rain Gutter Identification
Figure 1 (Sheet 1 of 2)**

**757-200
STRUCTURAL REPAIR MANUAL**

REF DWG
141N3410



SECTION THRU RAIN GUTTER
DETAIL II

ITEM	DESCRIPTION	GAGE	MATERIAL	EFFECTIVITY
1	GUTTER		BAC1498-356 CLAD 2024-T3	

LIST OF MATERIALS FOR DETAIL II

**Section 41 - Rain Gutter Identification
Figure 1 (Sheet 2 of 2)**

IDENTIFICATION 2
Page 2
Jan 20/2005

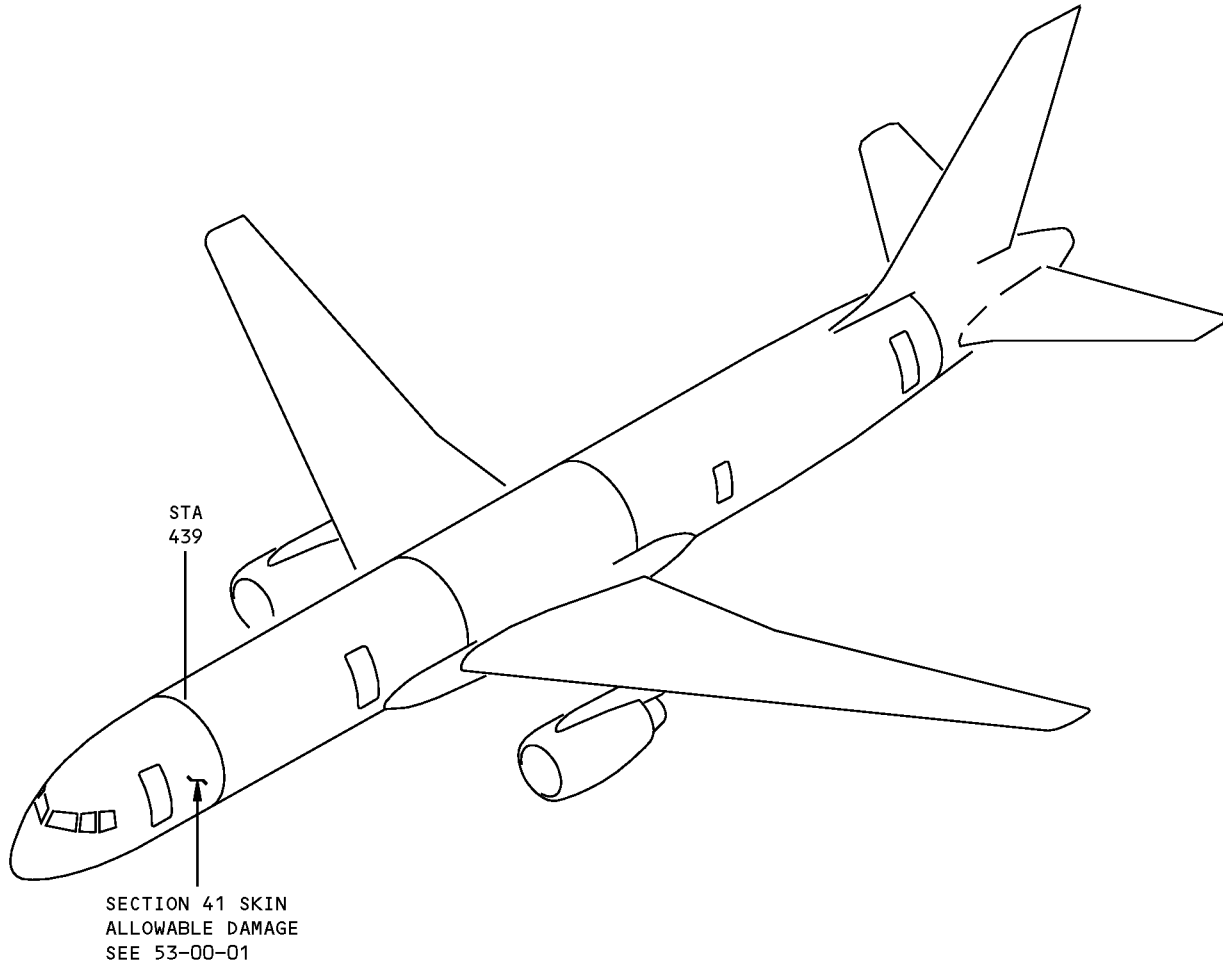
53-10-01

D634N201



757-200
STRUCTURAL REPAIR MANUAL

ALLOWABLE DAMAGE GENERAL - SECTION 41 - SKINS



Section 41 Skin Allowable Damage
Figure 101

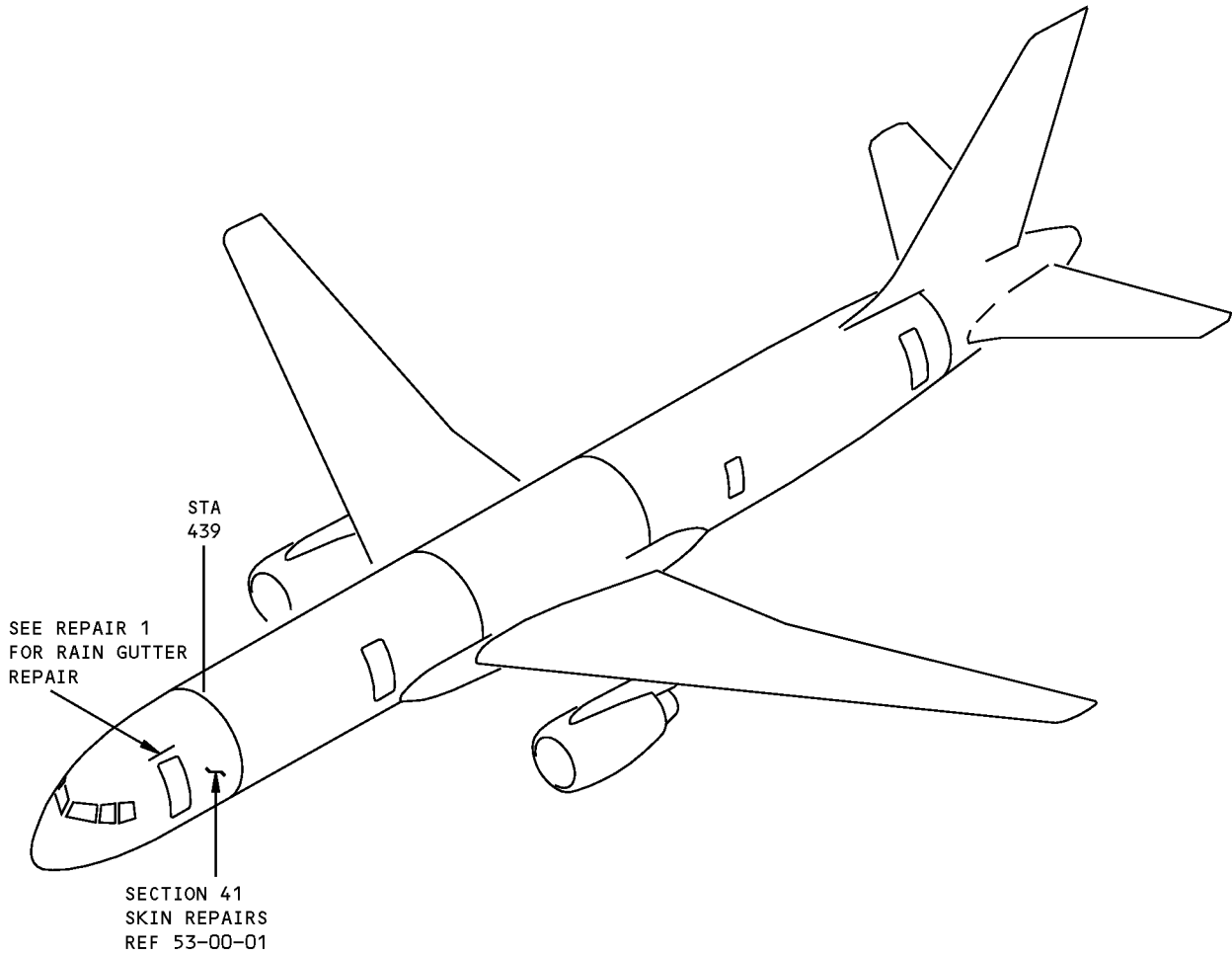
D634N201

ALLOWABLE DAMAGE GENERAL
Page 101
53-10-01
Jan 20/2007



757-200
STRUCTURAL REPAIR MANUAL

REPAIR GENERAL - SECTION 41 - FUSELAGE SKINS



Section 41 Fuselage Skins
Figure 201

D634N201

53-10-01

REPAIR GENERAL
Page 201
Jan 20/2005



757-200

STRUCTURAL REPAIR MANUAL

REPAIR 1 - RAIN GUTTER REPAIR AT PASSENGER/CREW ENTRY DOORS

REPAIR INSTRUCTIONS

1. Drill out any fasteners required to remove the existing rain gutter.
2. Remove any sealant and clean the surface of the skin in the reworked area.
3. Make a new rain gutter and drill the fastener holes. Space the holes as shown in Detail I for Passenger Entry Door (Left Side Door) and Detail II for Service Entry Door (Right Side Door).
4. Apply Alodine to the cut edges of the rain gutter and the surrounding skin. Prime and finish the same as the surrounding skin.
5. Install the new rain gutter with BACB30MY6K* fasteners. Cap and seal the fasteners with BMS 5-26 sealant and refinish reworked area per 51-20 of the 757 Maintenance Manual.

NOTE: The airplane may be returned to service without waiting for the sealant to cure.

SYMBOLS

- + EXISTING FASTENER LOCATION. INSTALL BACB30MY6K(X) HI-LOK WITH BACC30M COLLAR
- ⊞ EXISTING FASTENER LOCATION. INSTALL BACR15FT6D RIVET
- ⚡ EXISTING FASTENER LOCATION. INSTALL BACR15FT7D RIVET
- ⊕ EXISTING FASTENER LOCATION. INSTALL BACR15FT9AD RIVET
- ◆ REPAIR FASTENER LOCATION. INSTALL BACB30MY6K() HI-LOK WITH BACC30M COLLAR

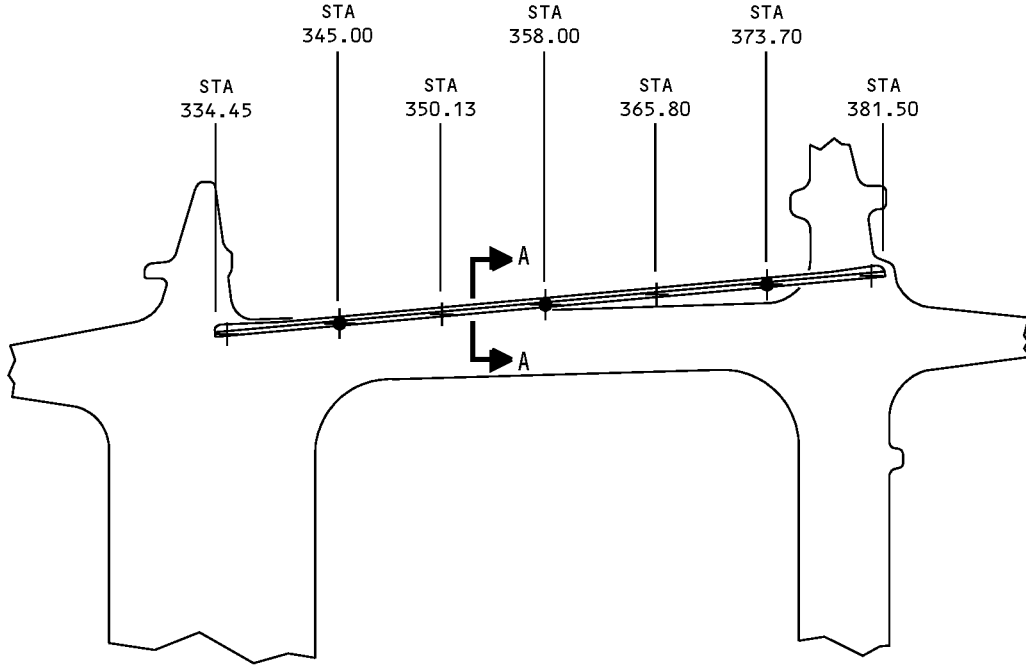
REPAIR MATERIAL			
PART		QTY	MATERIAL
1	RAIN GUTTER	1	BAC1496-356 CLAD 2024-T3

NOTES

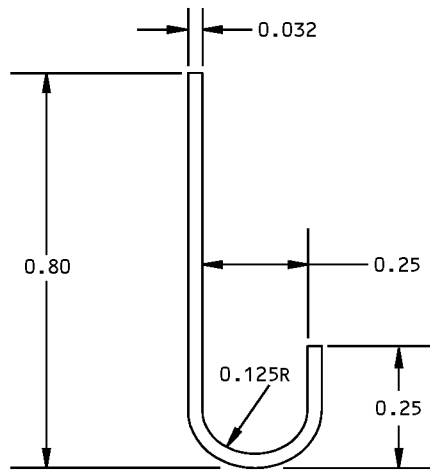
- REFER TO THE FOLLOWING WHEN MAKING THIS REPAIR
 - 51-20-01 FOR PROTECTIVE TREATMENT OF METAL
 - 51-20-05 FOR SEALING OF REPAIRS
 - 51-40 FOR FASTENER CODE, REMOVAL, INSTALLATION, HOLE SIZES AND EDGE MARGINS
 - 51-20 OF THE 757 MAINTENANCE MANUAL FOR INTERIOR AND EXTERIOR FINISHES

**Rain Gutter Repair at Passenger/Crew Entry Doors
Figure 201 (Sheet 1 of 3)**

**757-200
STRUCTURAL REPAIR MANUAL**



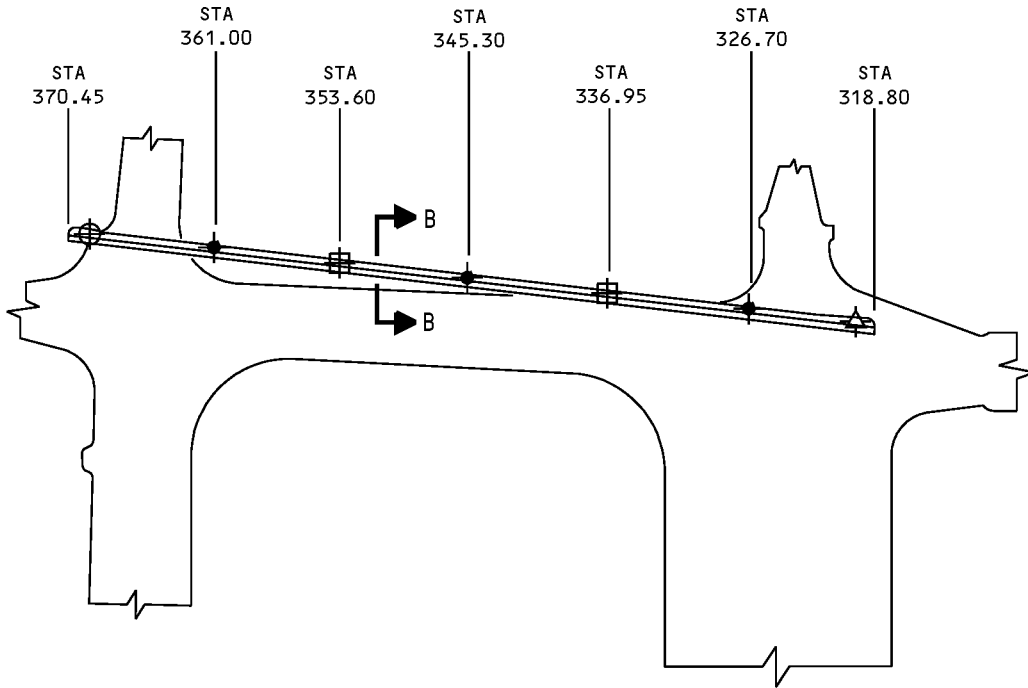
**NO. 1 PASSENGER ENTRY DOOR (LEFT SIDE)
DETAIL I**



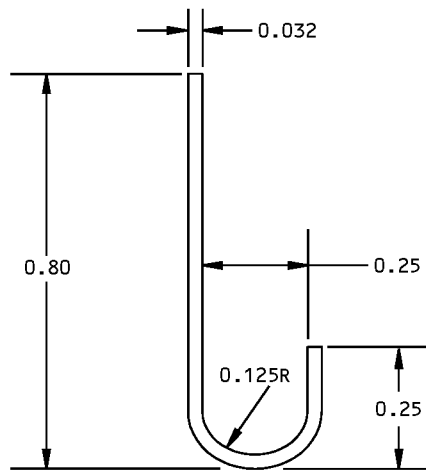
**RAIN GUTTER SHOWN ONLY
SECTION A-A**

**Rain Gutter Repair at Passenger/Crew Entry Doors
Figure 201 (Sheet 2 of 3)**

**757-200
STRUCTURAL REPAIR MANUAL**



**NO. 1 SERVICE DOOR (RIGHT SIDE)
DETAIL II**



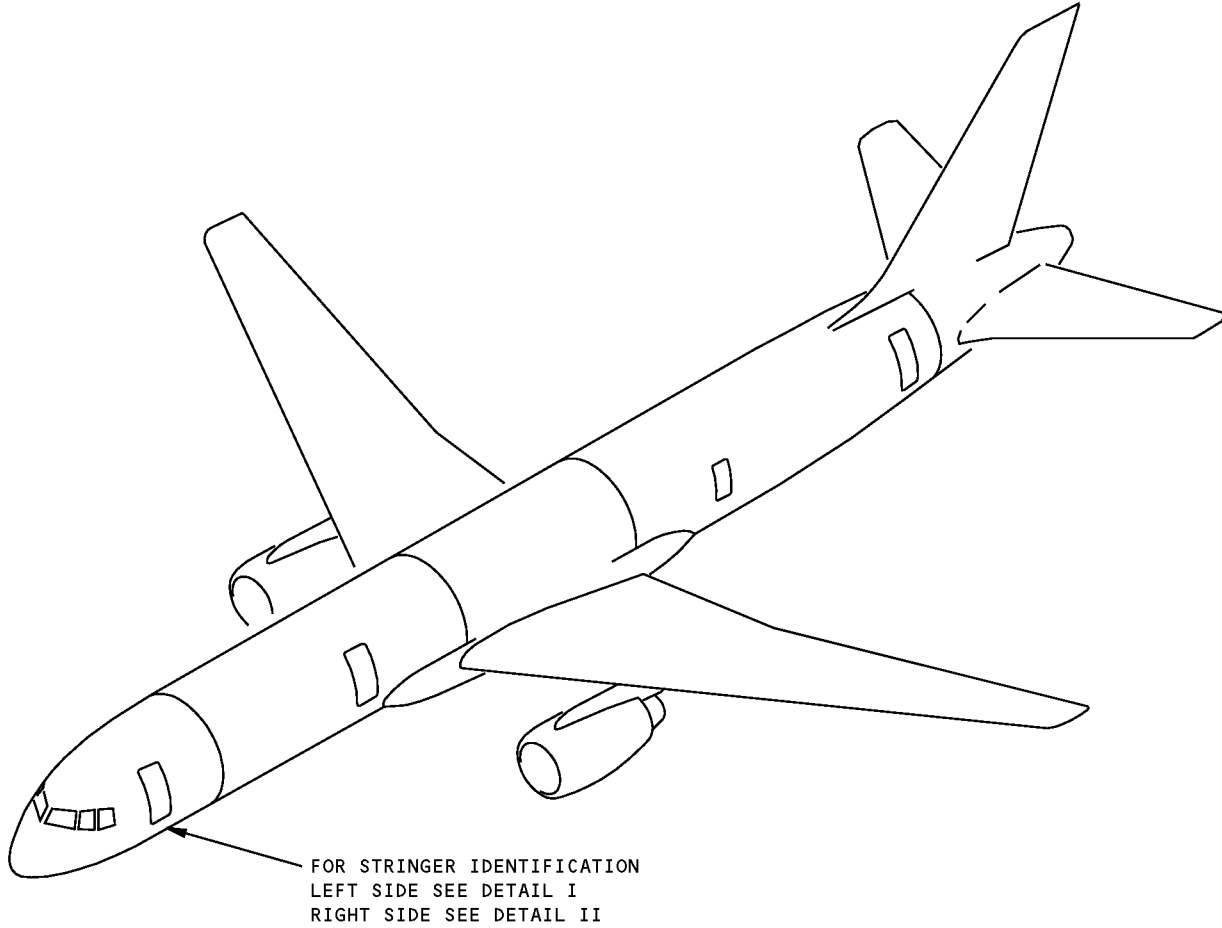
**RAIN GUTTER SHOWN ONLY
SECTION B-B**

**Rain Gutter Repair at Passenger/Crew Entry Doors
Figure 201 (Sheet 3 of 3)**



**757-200
STRUCTURAL REPAIR MANUAL**

IDENTIFICATION 1 - SECTION 41 - STRINGERS



**Section 41 Stringer Identification
Figure 1 (Sheet 1 of 5)**

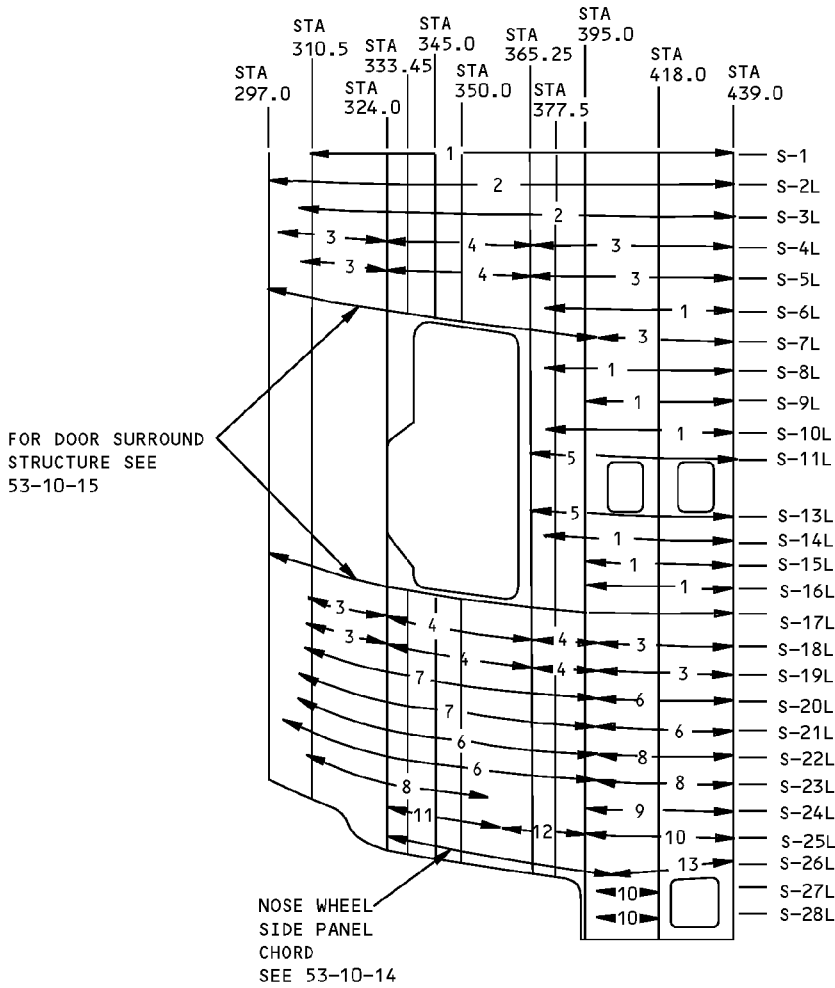
D634N201

53-10-03

IDENTIFICATION 1
Page 1
Jan 20/2005

**757-200
STRUCTURAL REPAIR MANUAL**

REF DWGS
140N1530
141N3270
141N3370
141N3470



LEFT SIDE
DETAIL I



**Section 41 Stringer Identification
Figure 1 (Sheet 2 of 5)**

IDENTIFICATION 1
Page 2
Jan 20/2005

53-10-03

D634N201



757-200
STRUCTURAL REPAIR MANUAL

ITEM	DESCRIPTION	GAGE	MATERIAL	TYPE	REF DWG	EFFECTIVITY
1	STRINGER	0.032	7075-T6		141N3370	
2	STRINGER	0.040	7075-T6		141N3370	
3	STRINGER	0.063 A	7075-T6		141N3370	
4	STRINGER	0.063	7075-T6		141N3370	
5	STRINGER		BAC1517-1471 7075-T6		141N3371	
6	STRINGER	0.032	7075-T6		141N3270	
7	STRINGER	0.050	7075-T6		141N3270	
8	STRINGER	0.040	7075-T6		141N3270	
9	STRINGER	0.063 A	7075-T6		141N3270	
10	STRINGER	0.063	7075-T6		141N3270	
11	STRINGER		AND10140-1204 2024-T3511		141N8930	
12	STRINGER		AND10136-2401 2024-T3511		141N8930	
13	STRINGER	0.080	7075-T6		141N3270	

LIST OF MATERIALS FOR DETAIL I

NOTES

A GAGE VARIES THROUGHOUT THE LENGTH,
MAXIMUM GAGE GIVEN

Section 41 Stringer Identification
Figure 1 (Sheet 3 of 5)

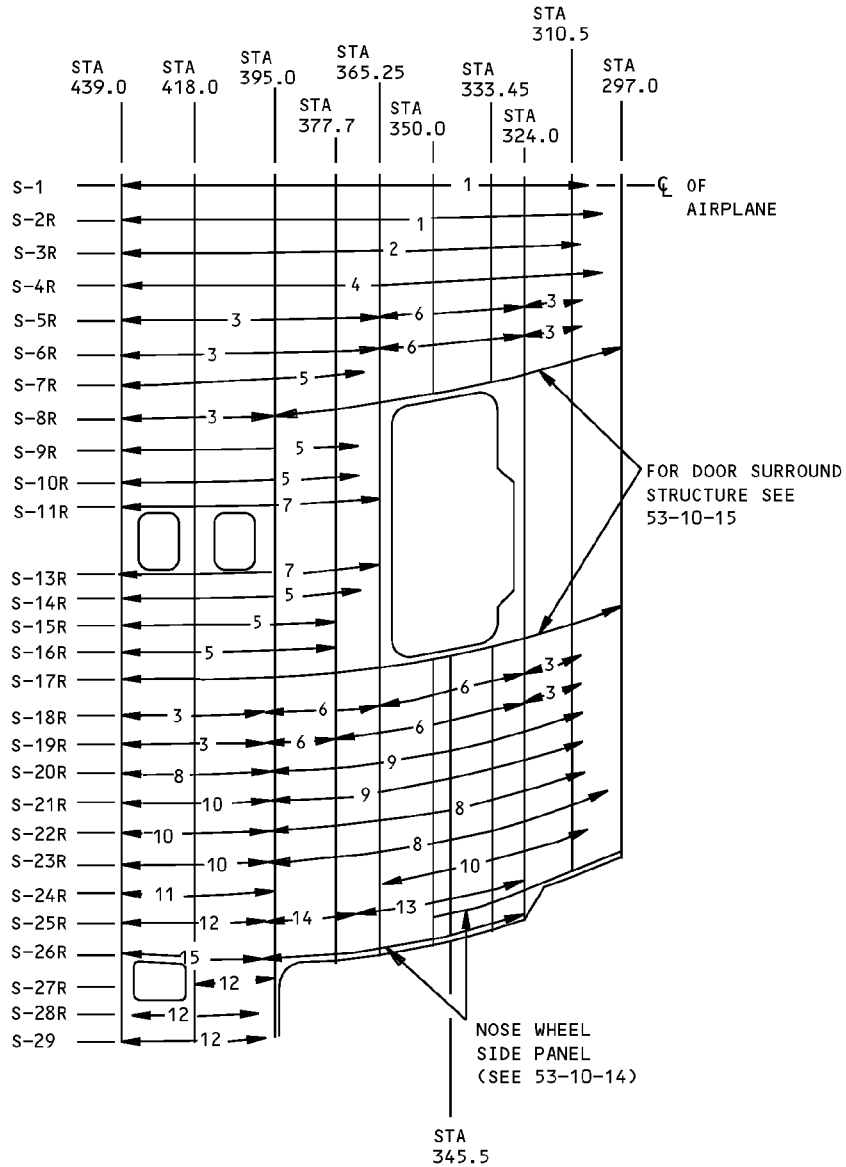
D634N201

53-10-03

IDENTIFICATION 1
Page 3
Jan 20/2005

**757-200
STRUCTURAL REPAIR MANUAL**

REF DWGS
140N1530
141N3270
141N3370
141N3470



**RIGHT SIDE
DETAIL II**



**Section 41 Stringer Identification
Figure 1 (Sheet 4 of 5)**
















IDENTIFICATION 1
Page 4
Jan 20/2005

53-10-03

D634N201



757-200
STRUCTURAL REPAIR MANUAL

ITEM	DESCRIPTION	GAGE	MATERIAL	TYPE	REF DWG	EFFECTIVITY
1	STRINGER	0.032	7075-T6		141N3370	
2	STRINGER	0.040	7075-T6		141N3370	
3	STRINGER	0.063 A	7075-T6		141N3470	
4	STRINGER	0.040	7075-T6		141N3470	
5	STRINGER	0.032	7075-T6		141N3470	
6	STRINGER	0.063	7075-T6		141N3470	
7	STRINGER		BAC1517-1471 7075-T6		141N3471	
8	STRINGER	0.032	7075-T6		141N3270	
9	STRINGER	0.050	7075-T6		141N3270	
10	STRINGER	0.040	7075-T6		141N3270	
11	STRINGER	0.063 A	7075-T6		141N3270	
12	STRINGER	0.063	7075-T6		141N3270	
13	STRINGER		AND10140-1204 2024-T3511		141N8930	
14	STRINGER		AND10136-2401 2024-T3511		141N8930	
15	STRINGER	0.080	7075-T6		141N3270	

LIST OF MATERIALS FOR DETAIL II

NOTES

A GAGE VARIES THROUGHOUT THE LENGTH,
MAXIMUM GAGE GIVEN

Section 41 Stringer Identification
Figure 1 (Sheet 5 of 5)

D634N201

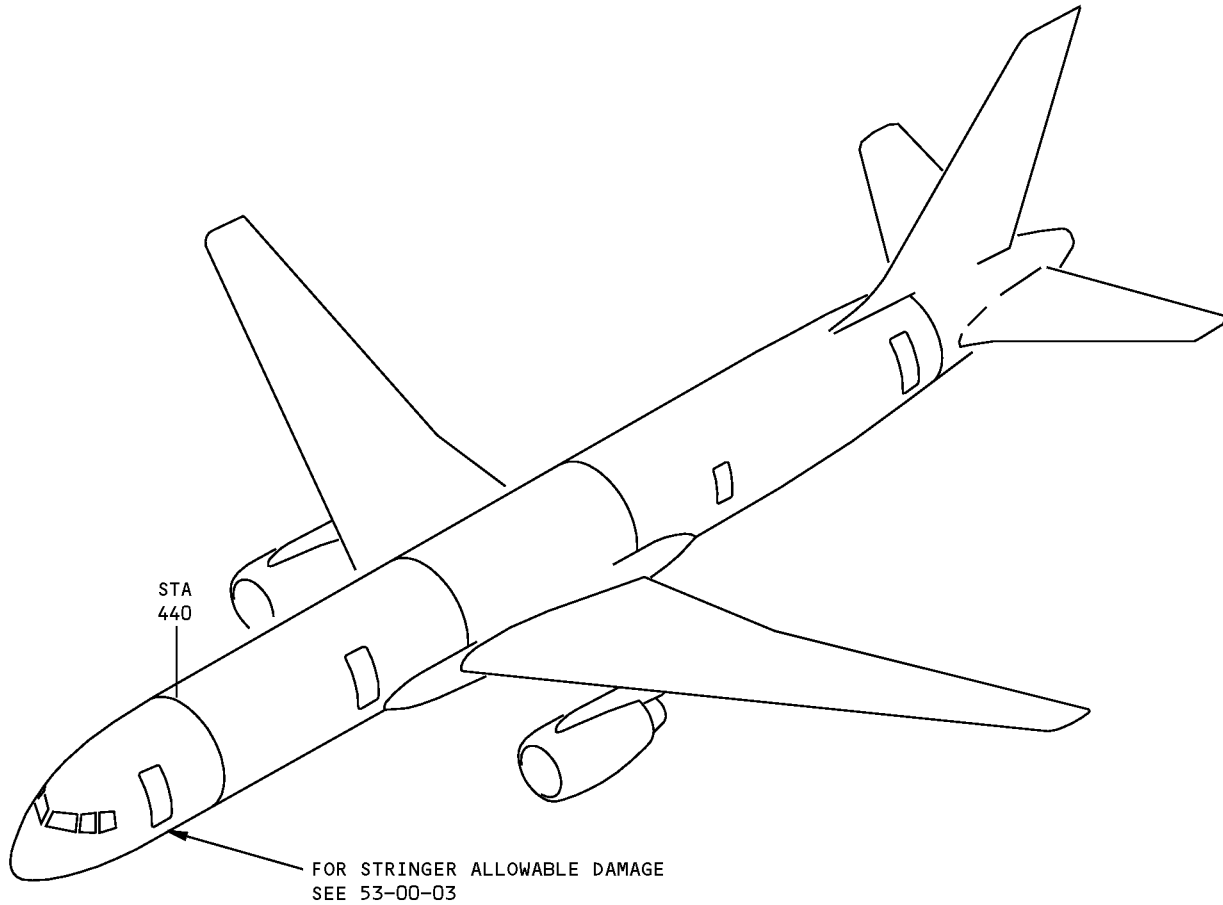
53-10-03

IDENTIFICATION 1
Page 5
Jan 20/2005



757-200
STRUCTURAL REPAIR MANUAL

ALLOWABLE DAMAGE GENERAL - SECTION 41 - STRINGERS



Section 41 Stringer Allowable Damage
Figure 101

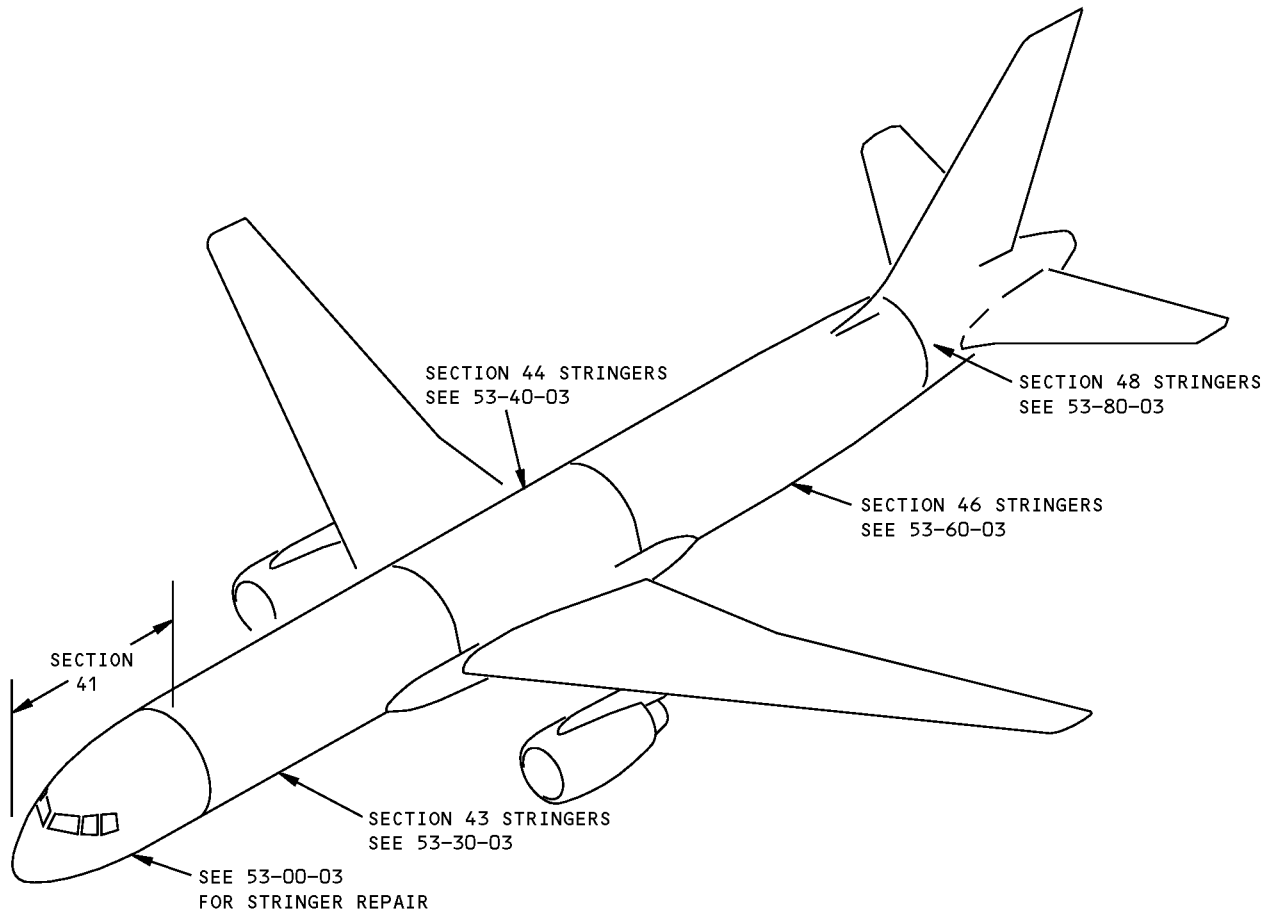
D634N201

ALLOWABLE DAMAGE GENERAL
Page 101
53-10-03 Jan 20/2005



757-200
STRUCTURAL REPAIR MANUAL

REPAIR GENERAL - SECTION 41 - STRINGERS



Section 41 Stringer Repair
Figure 201

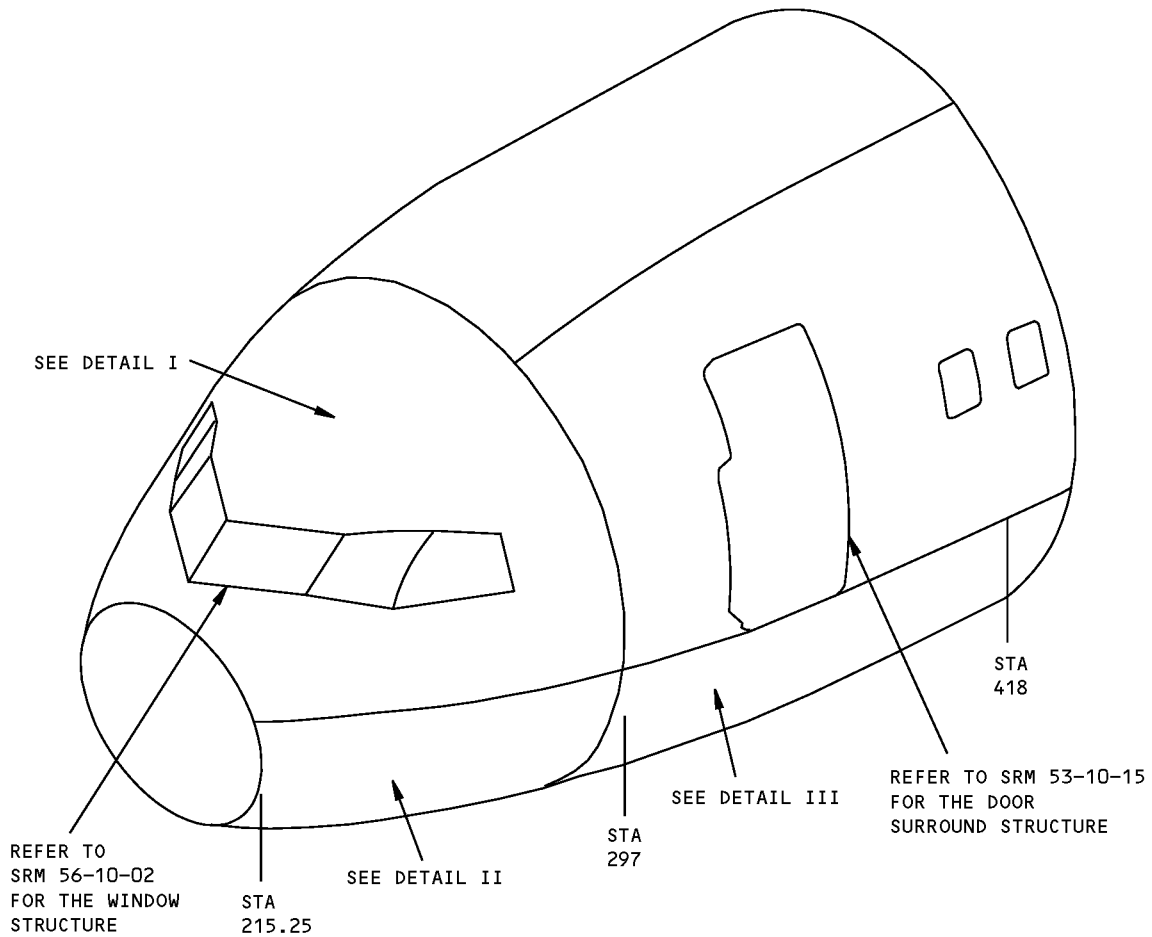
D634N201

53-10-03

REPAIR GENERAL
Page 201
Jan 20/2005

**757-200
STRUCTURAL REPAIR MANUAL**

IDENTIFICATION 1 - SECTION 41 - INTERCOSTALS

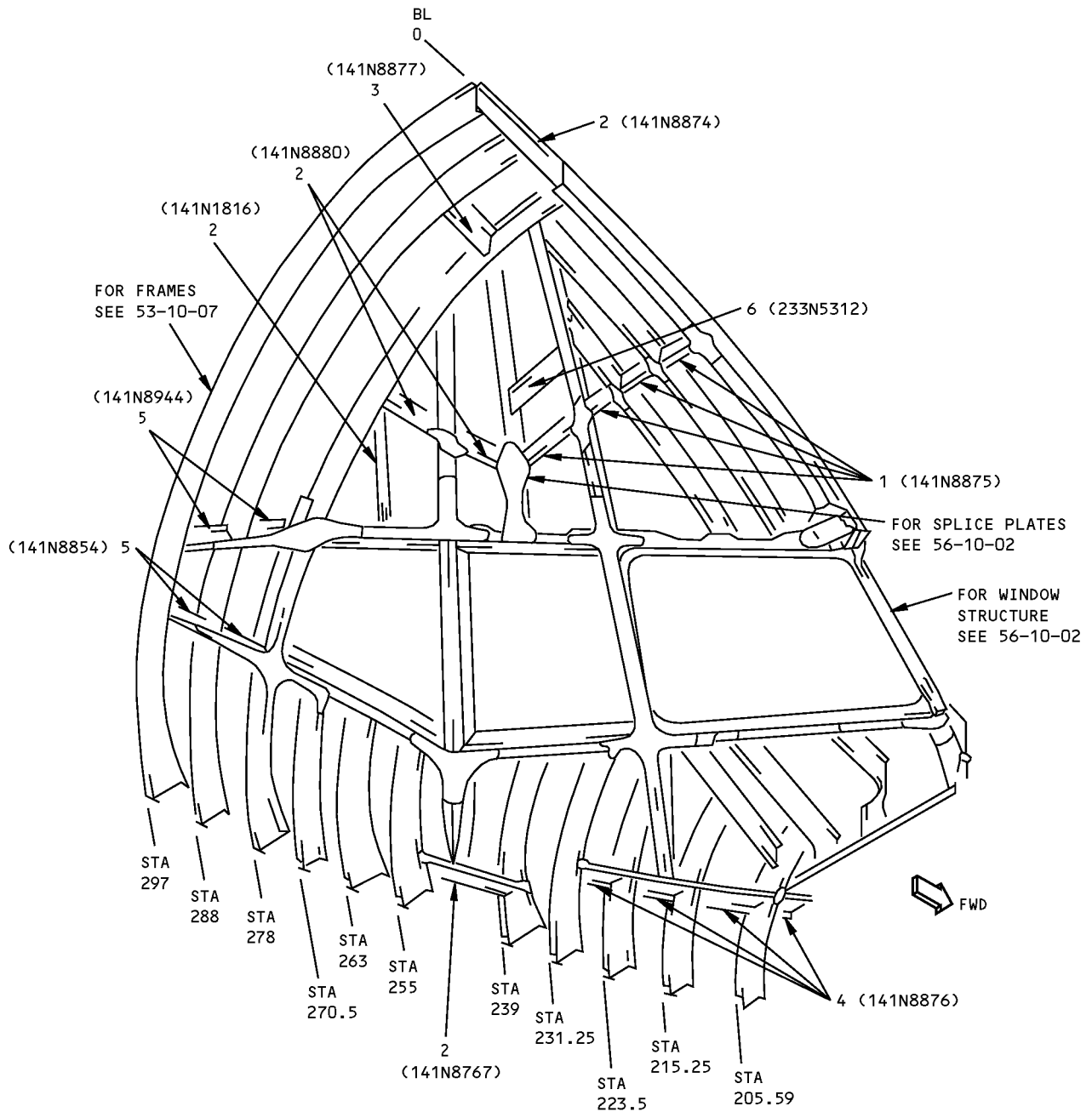


NOTES

A FOR CUM LINE NUMBERS:
805 AND ON

**Section 41 Intercostal Identification
Figure 1 (Sheet 1 of 5)**

**757-200
STRUCTURAL REPAIR MANUAL**



LEFT SIDE SHOWN
RIGHT SIDE OPPOSITE
DETAIL I

LIST OF
MATL

**Section 41 Intercostal Identification
Figure 1 (Sheet 2 of 5)**



**757-200
STRUCTURAL REPAIR MANUAL**

ITEM	DESCRIPTION	GAGE	MATERIAL	EFFECTIVITY
1	INTERCOSTAL		FORGED BLOCK 7075-T73	
2	INTERCOSTAL CHORD WEB	0.080 0.080	CLAD 7075-T6 CLAD 7075-T6	
3	INTERCOSTAL	0.050	2024-T42 CHEM-MILLED	
4	INTERCOSTAL CHORD WEB	0.063 0.063	7075-T6 7075-T6	
5	INTERCOSTAL CHORD WEB	0.080 0.100	7075-T6 7075-T6	
6	INTERCOSTAL	0.080	CLAD 2024-T42	

LIST OF MATERIALS FOR DETAIL I

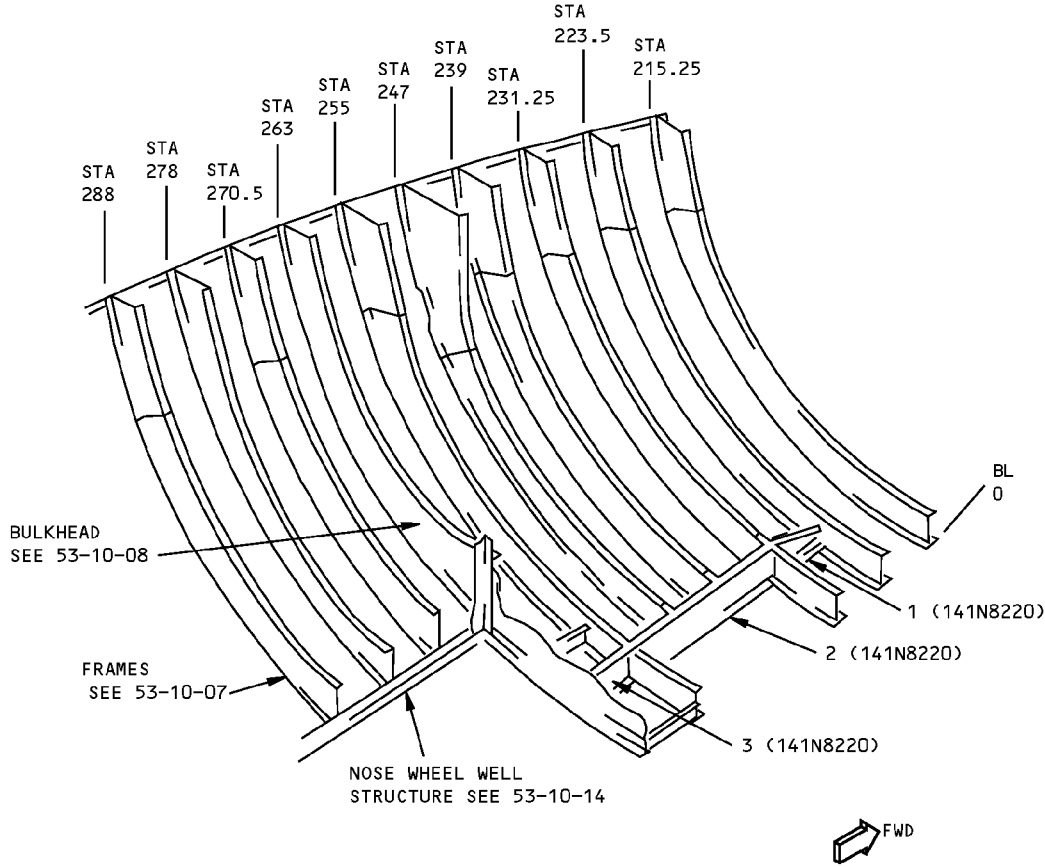
**Section 41 Intercostal Identification
Figure 1 (Sheet 3 of 5)**

D634N201

53-10-04

IDENTIFICATION 1
Page 3
Jan 20/2005

**757-200
STRUCTURAL REPAIR MANUAL**



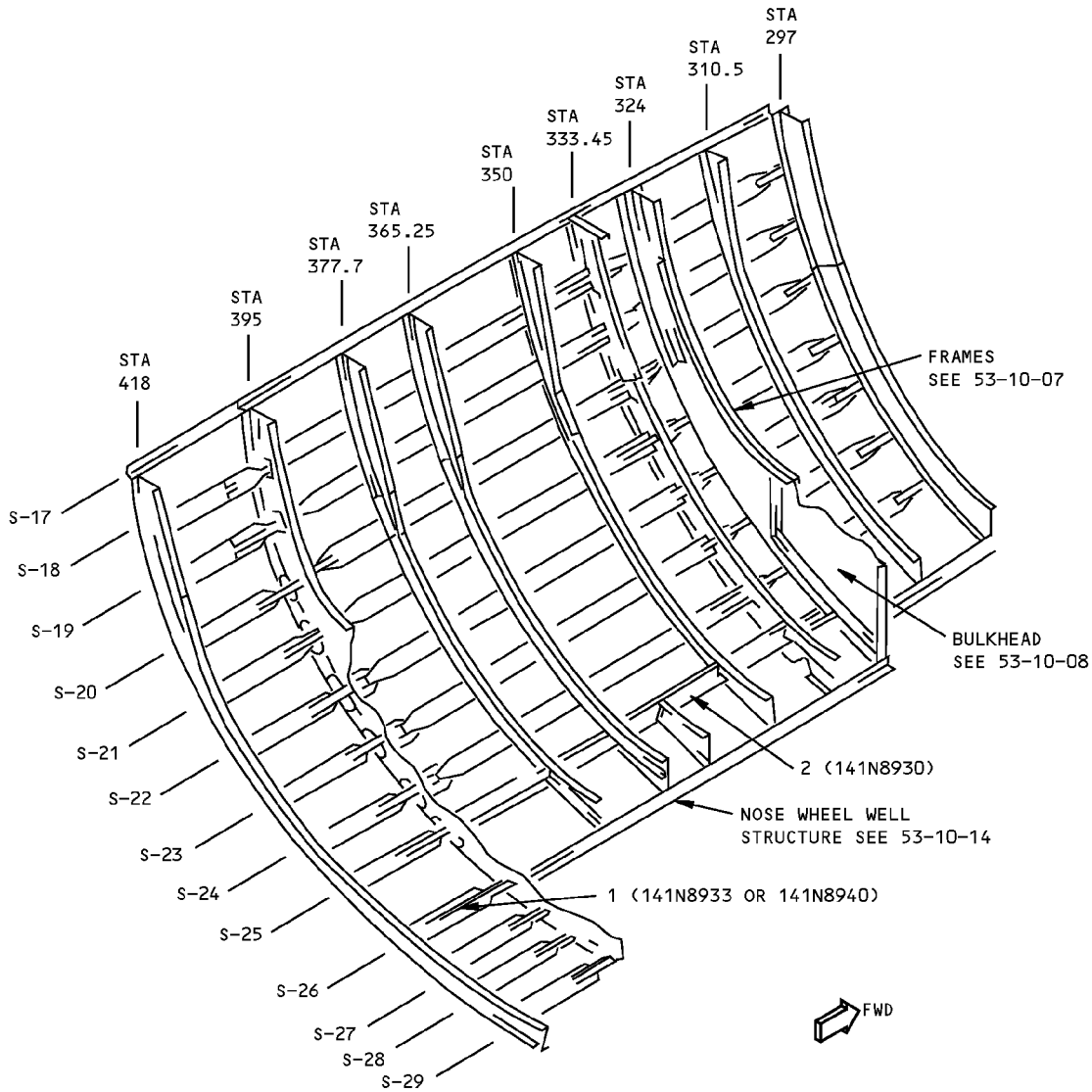
DETAIL II

ITEM	DESCRIPTION	GAGE	MATERIAL	EFFECTIVITY
1	INTERCOSTAL	0.050	CLAD 2024-T3	A
2	INTERCOSTAL	0.050	BAC1506-3160 2024-T3511 CLAD 2024-T3 BAC1514-533 2024-T3511	
	OUTER CHORD			
	WEB			
	INNER CHORD			
3	INTERCOSTAL	0.063	BAC1506-3160 2024-T3511 MACHINED PLATE 7050-T7451 CLAD 2024-T3 BAC1514-533 2024-T3511	
	OUTER CHORD			
	WEB			
	INNER CHORD			

LIST OF MATERIALS FOR DETAIL II

**Section 41 Intercostal Identification
Figure 1 (Sheet 4 of 5)**

**757-200
STRUCTURAL REPAIR MANUAL**



DETAIL III

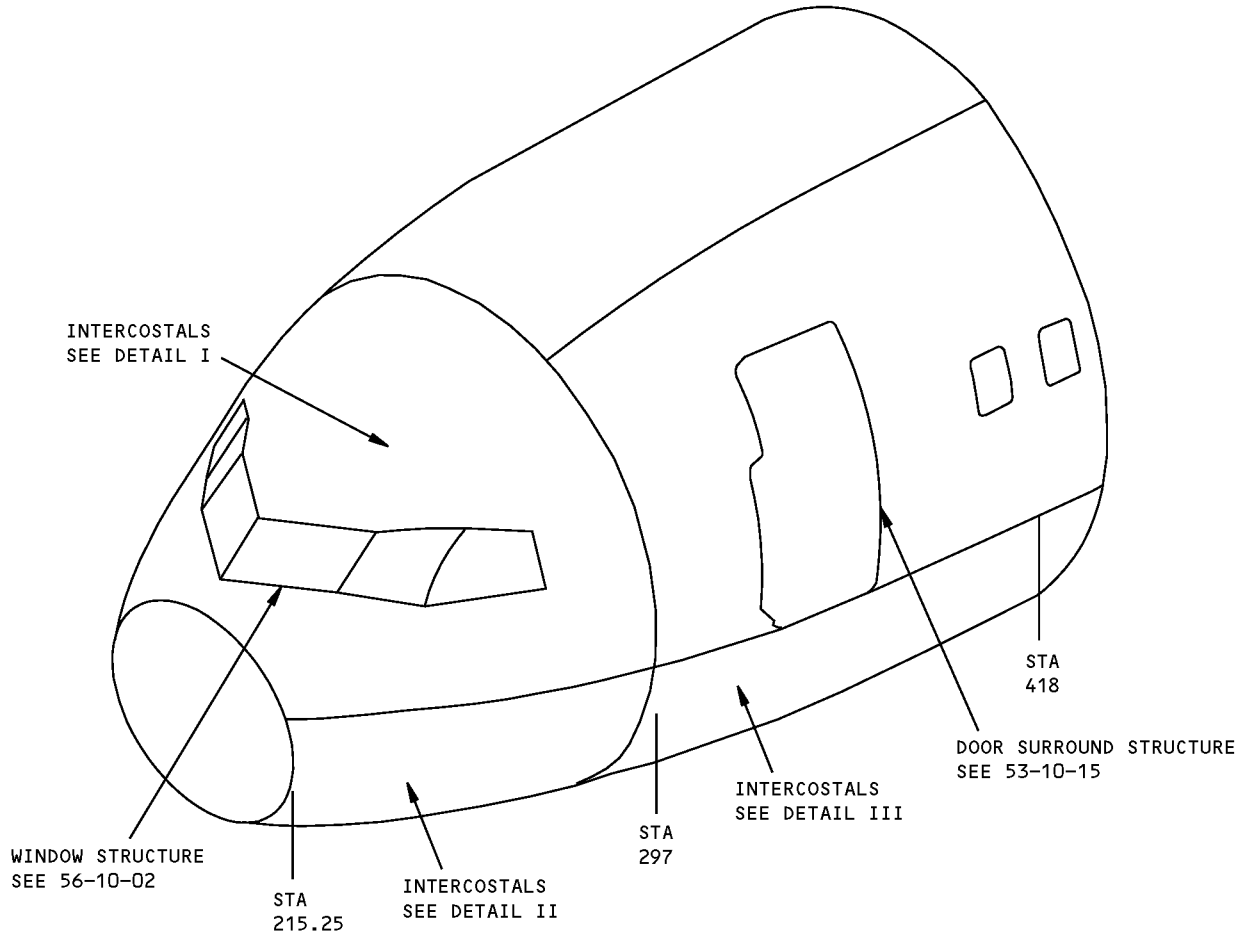
ITEM	DESCRIPTION	GAGE	MATERIAL	EFFECTIVITY
1	INTERCOSTAL	1.20	FORGING 7075-T73 OR MACHINED PLATE 7075-T7351	
2	INTERCOSTAL	0.050	CLAD 2024-T3	

LIST OF MATERIALS FOR DETAIL III

**Section 41 Intercostal Identification
Figure 1 (Sheet 5 of 5)**

**757-200
STRUCTURAL REPAIR MANUAL**

ALLOWABLE DAMAGE GENERAL - SECTION 41 - INTERCOSTALS

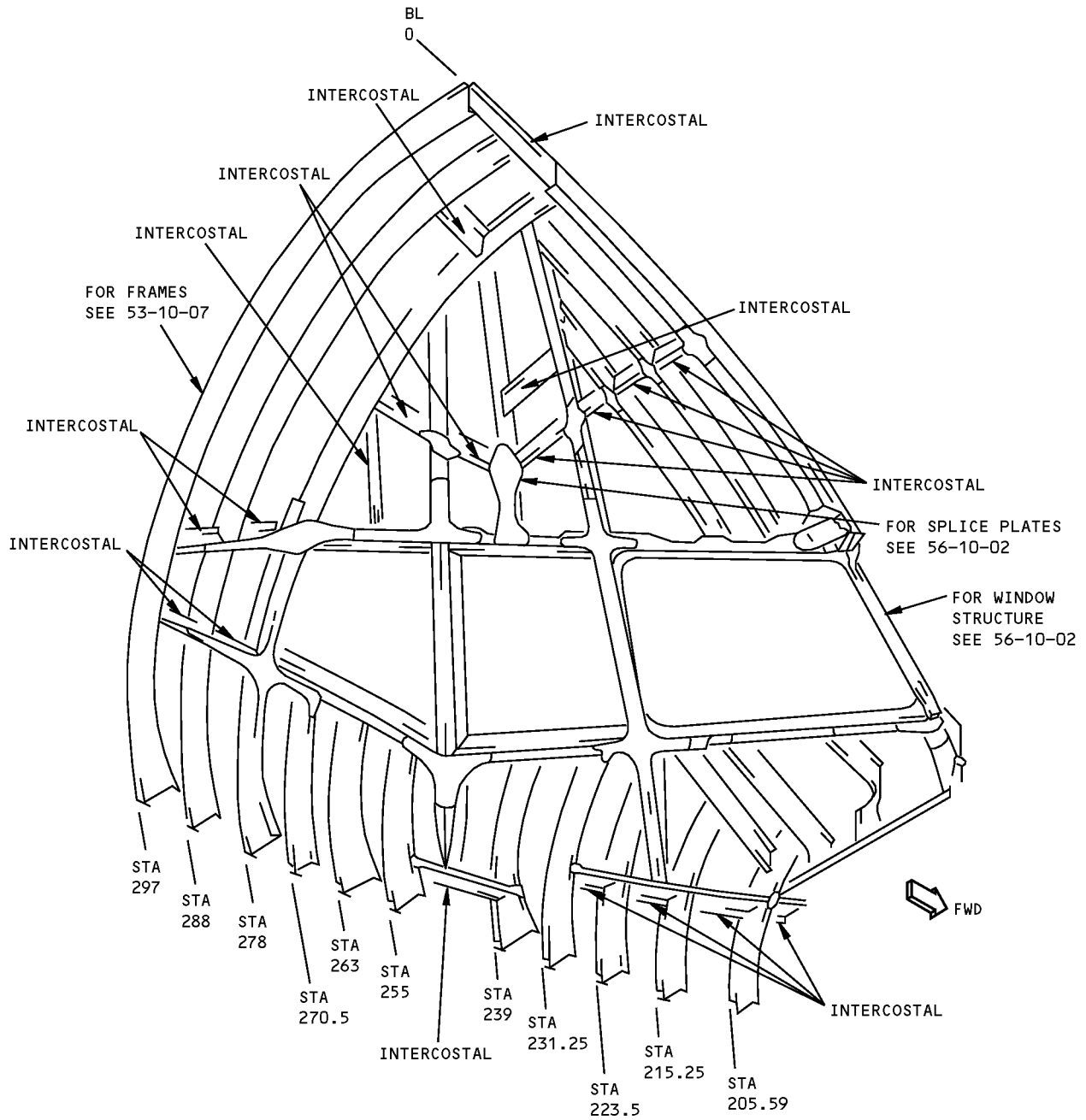


NOTES

- REFER TO 53-00-04 FOR INTERCOSTAL ALLOWABLE DAMAGE DATA

**Section 41 Intercostal Allowable Damage
Figure 101 (Sheet 1 of 3)**

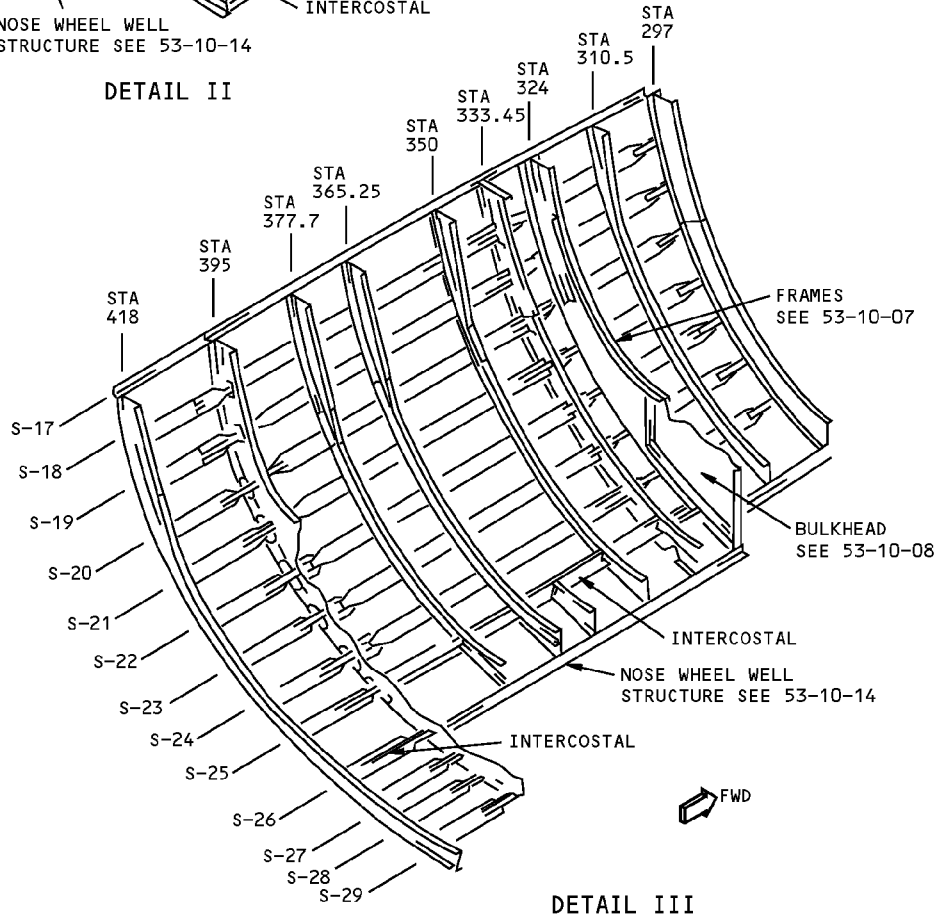
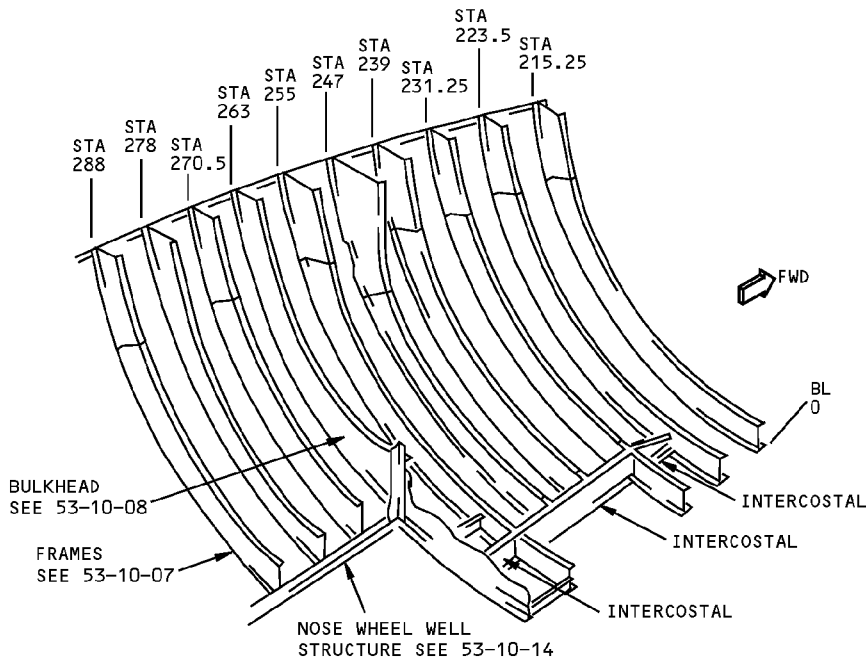
**757-200
STRUCTURAL REPAIR MANUAL**



LEFT SIDE SHOWN
RIGHT SIDE OPPOSITE
DETAIL I

**Section 41 Intercostal Allowable Damage
Figure 101 (Sheet 2 of 3)**

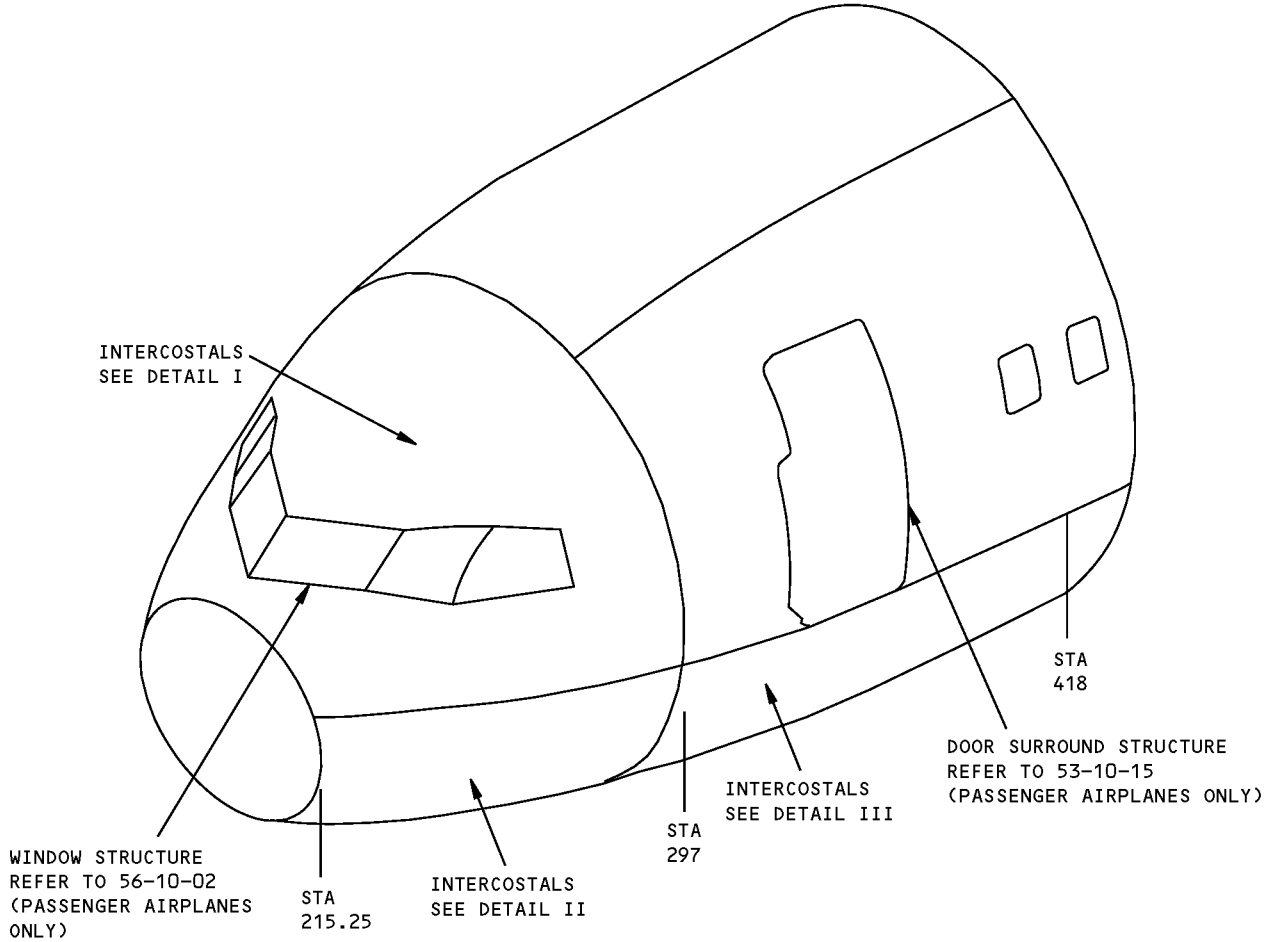
**757-200
STRUCTURAL REPAIR MANUAL**



**Section 41 Intercostal Allowable Damage
Figure 101 (Sheet 3 of 3)**

**757-200
STRUCTURAL REPAIR MANUAL**

REPAIR GENERAL - SECTION 41 - INTERCOSTALS

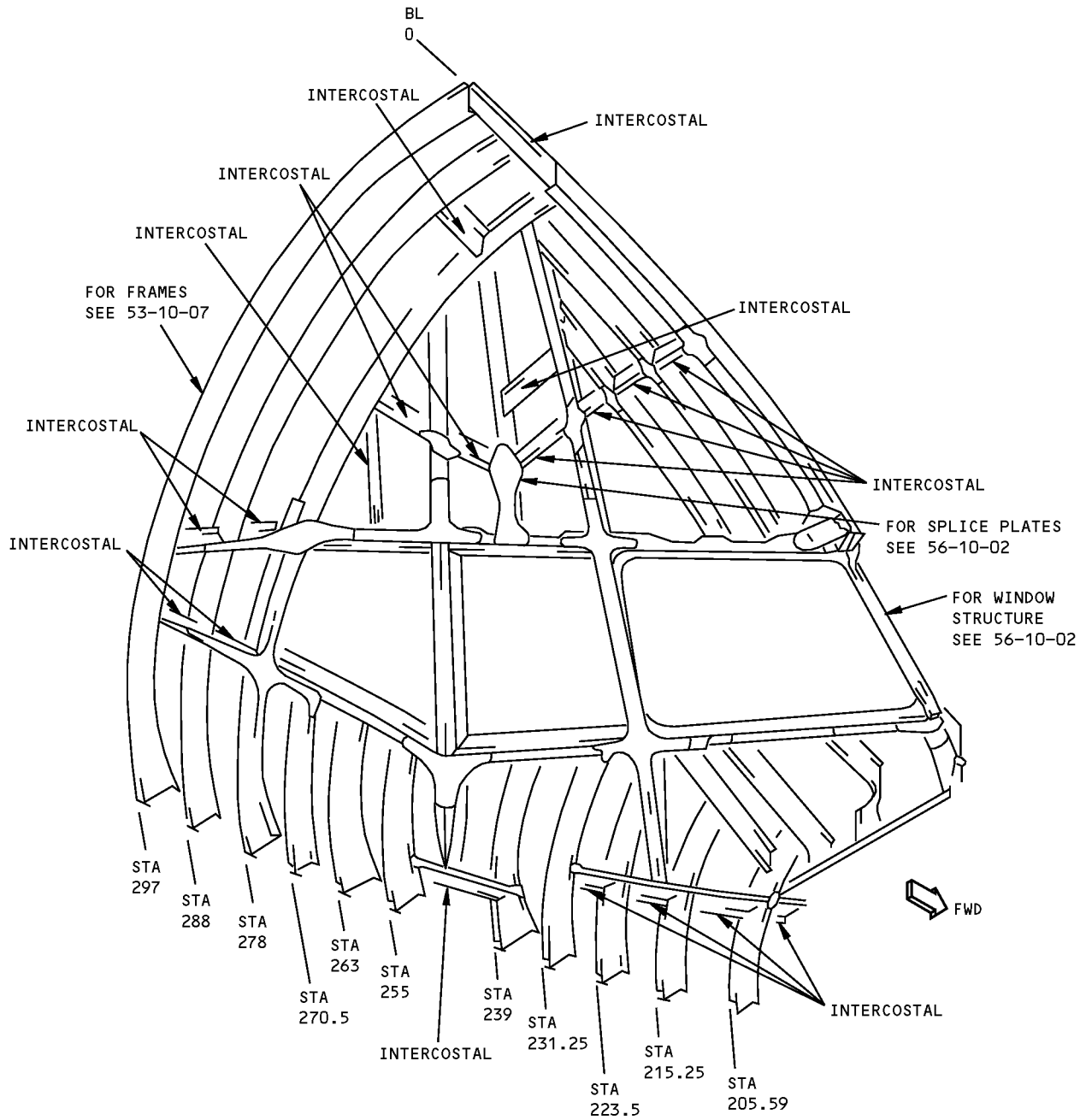


NOTES

- DAMAGED COMPONENTS MAY BE REPLACED OR REPAIRED. IF REPAIRS ARE TO BE MADE, SEE 51-70 FOR TYPICAL WEB, FORMED SECTION, OR EXTRUDED SECTION REPAIRS

**Section 41 Intercostal Repair
Figure 201 (Sheet 1 of 3)**

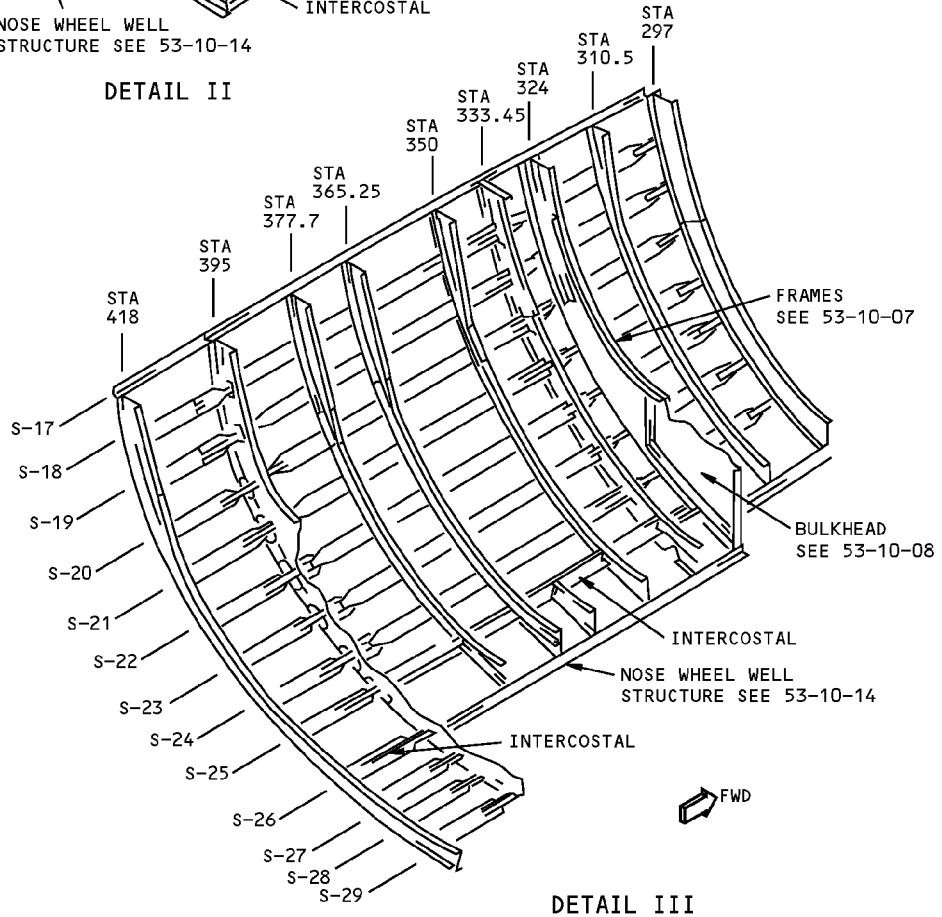
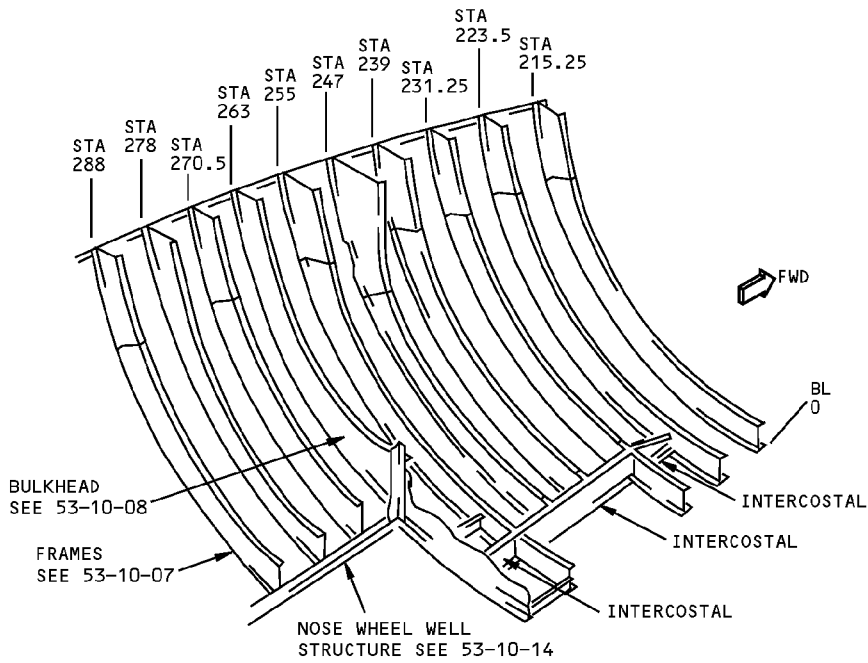
**757-200
STRUCTURAL REPAIR MANUAL**



LEFT SIDE SHOWN
RIGHT SIDE OPPOSITE
DETAIL I

**Section 41 Intercostal Repair
Figure 201 (Sheet 2 of 3)**

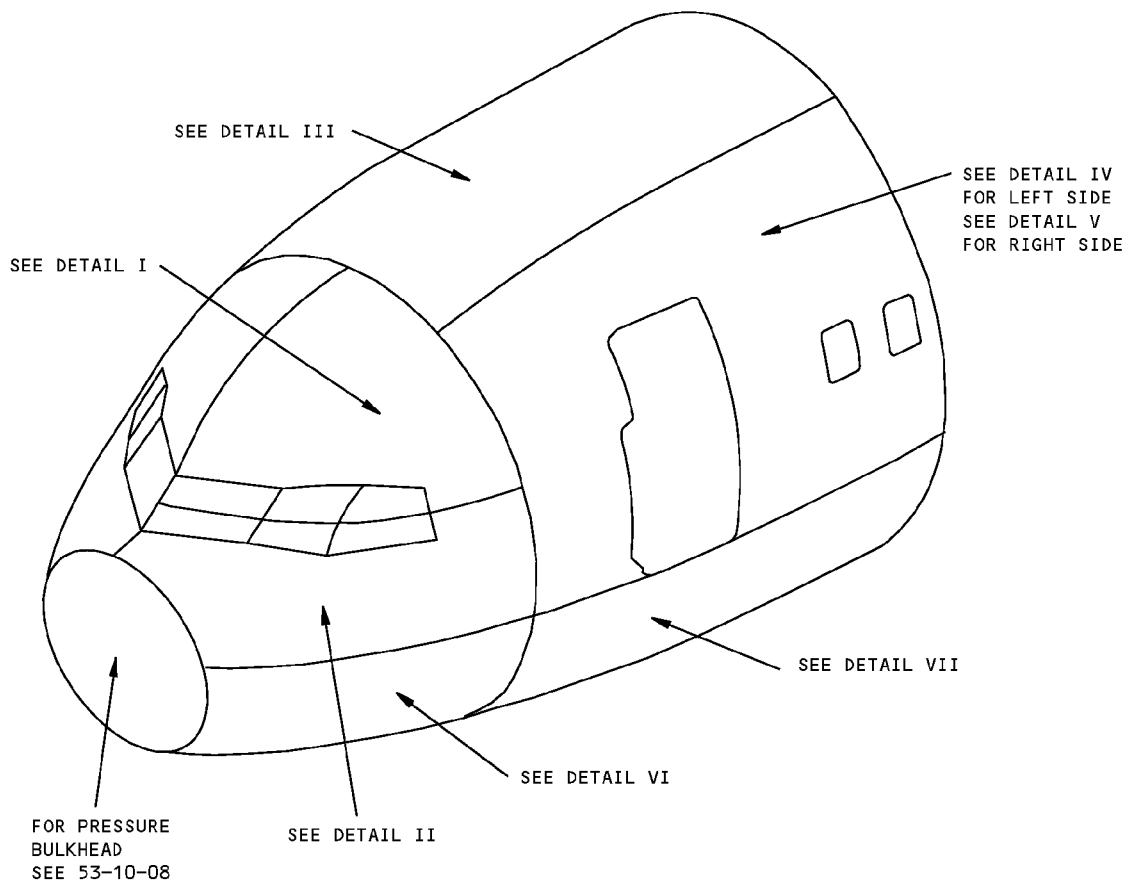
**757-200
STRUCTURAL REPAIR MANUAL**



**Section 41 Intercostal Repair
Figure 201 (Sheet 3 of 3)**

757-200
STRUCTURAL REPAIR MANUAL

IDENTIFICATION 1 - SECTION 41 - FRAMES



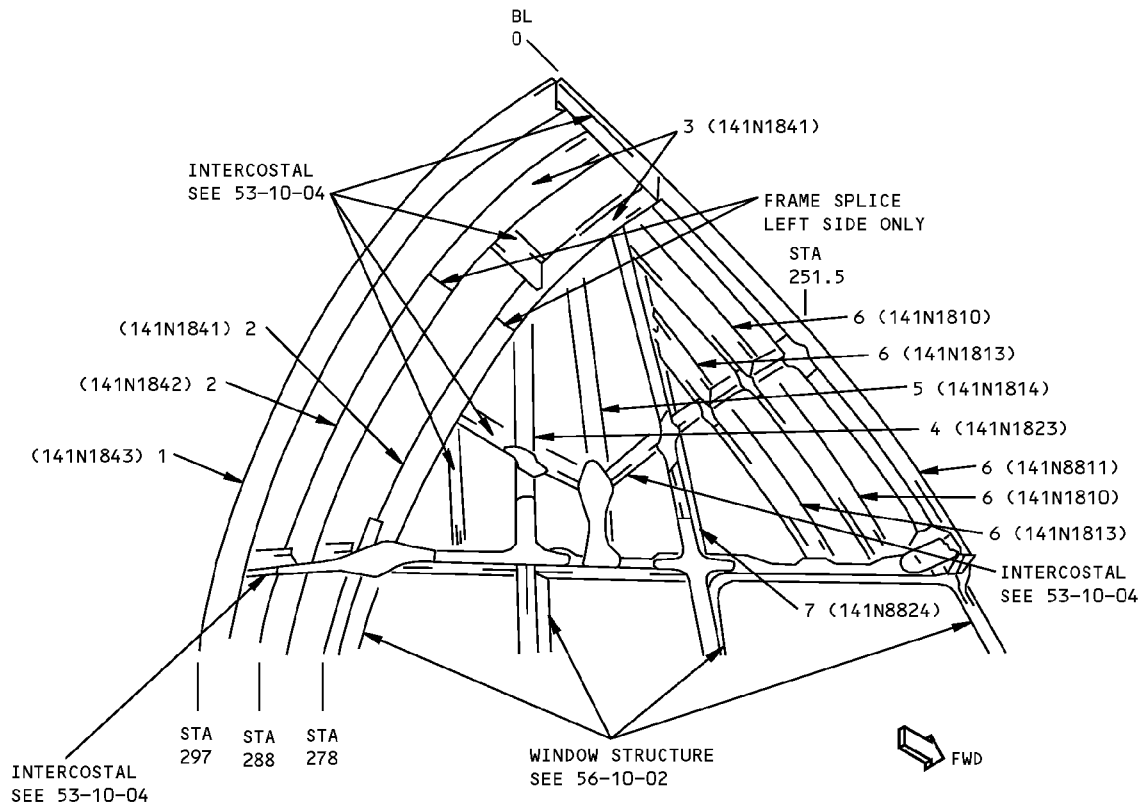
NOTES

- [A]** FOR CUM LINE NUMBERS:
1 THRU 11
- [B]** FOR ALL AIRPLANES EXCEPT THOSE IN **[A]**
- [C]** FOR ALL AIRPLANES EXCEPT THOSE IN **[D]**
- [D]** FOR CUM LINE NUMBERS:
1 THRU 30

Section 41 Frame Identification
Figure 1 (Sheet 1 of 11)

**757-200
STRUCTURAL REPAIR MANUAL**

REF DWG
140N1510



LEFT SIDE SHOWN
RIGHT SIDE OPPOSITE
DETAIL I



**Section 41 Frame Identification
Figure 1 (Sheet 2 of 11)**

IDENTIFICATION 1
Page 2
Jan 20/2005

53-10-07

D634N201



757-200
STRUCTURAL REPAIR MANUAL

ITEM	DESCRIPTION	GAGE	MATERIAL	EFFECTIVITY
1	FRAME OUTER CHORD WEB	0.063	BAC1506-3360 2024-T42 CLAD 7075-T6	
2	FRAME OUTER CHORD WEB	0.063 0.063	CLAD 7075-T6 CLAD 7075-T6	
3	FRAME OUTER CHORD WEB	0.063	BAC1506-2174 7075-T6 CLAD 7075-T6	
4	FRAME CHANNELS	0.080	CLAD 7075-T6 (BACK-TO-BACK CHANNELS)	
5	FRAME CHANNELS	0.100	CLAD 7075-T6 (BACK-TO-BACK CHANNELS)	
6	FRAME		FORGING 7075-T73	
7	FRAME CHANNELS	0.080	2024-T42 CHEM-MILLED (BACK-TO-BACK CHANNELS)	

LIST OF MATERIALS FOR DETAIL I

Section 41 Frame Identification
Figure 1 (Sheet 3 of 11)

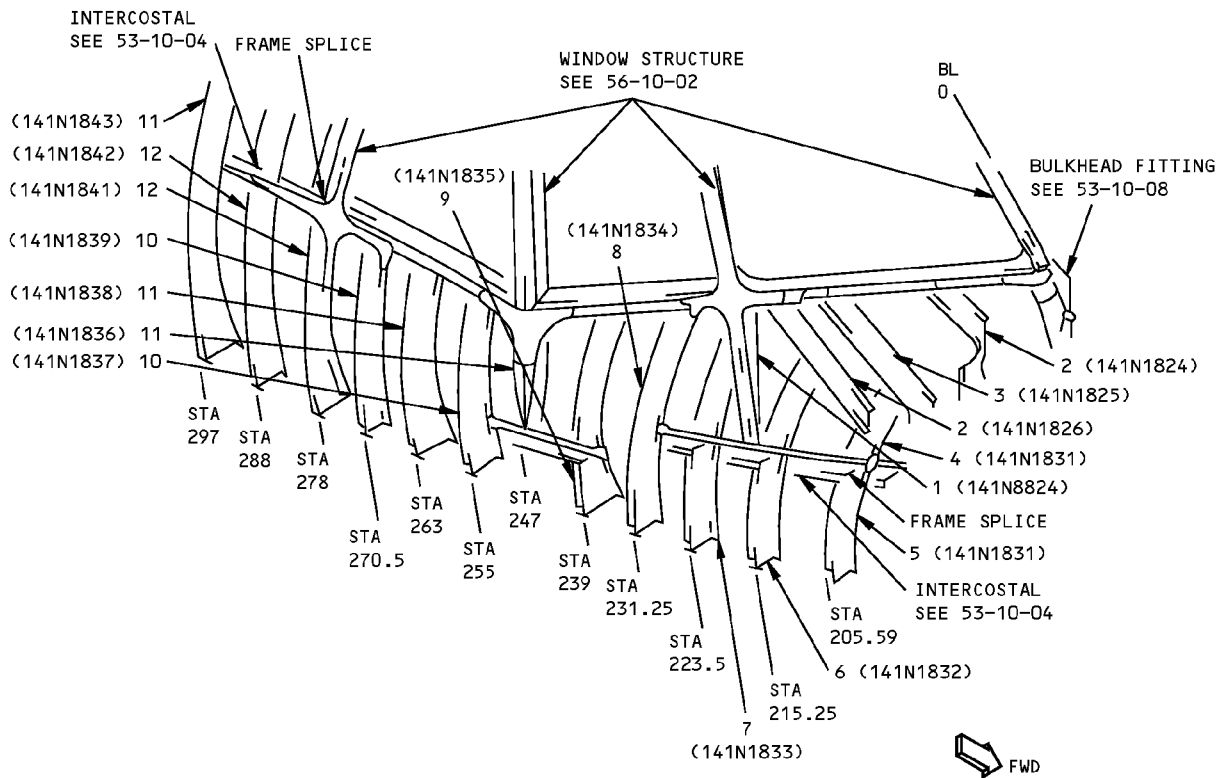
D634N201

53-10-07

IDENTIFICATION 1
Page 3
Jan 20/2005

**757-200
STRUCTURAL REPAIR MANUAL**

REF DWG
140N1510



LEFT SIDE SHOWN
RIGHT SIDE OPPOSITE
DETAIL II



**Section 41 Frame Identification
Figure 1 (Sheet 4 of 11)**

IDENTIFICATION 1
Page 4
Jan 20/2005

53-10-07

D634N201



**757-200
STRUCTURAL REPAIR MANUAL**

ITEM	DESCRIPTION	GAGE	MATERIAL	EFFECTIVITY			
1	FRAME CHANNELS	0.080	7075-T6 (2)				
2	FRAME	0.080	CLAD 7075-T6				
3	FRAME FORMER STIFFENER FITTING	0.080	CLAD 7075-T6 BAC1503-100505 7075-T6511 FORGED BLOCK 7075-T73	<table border="1"> <tr><td>A</td></tr> <tr><td>A</td></tr> <tr><td>B</td></tr> </table>	A	A	B
A							
A							
B							
4	FRAME OUTER CHORD WEB	0.063	BAC1506-3157 2024-T42 CLAD 7075-T6				
5	FRAME OUTER CHORD WEB	0.050	BAC1506-3358 2024-T42 CLAD 7075-T6				
6	FRAME OUTER CHORD WEB	0.063	BAC1506-3358 2024-T42 CLAD 7075-T6				
7	FRAME OUTER CHORD OUTER CHORD WEB INNER CHORD	0.063 0.071	BAC1506-2032 2024-T42 BAC1506-3361 2024-T42 CLAD 7075-T6 CLAD 7075-T6	<table border="1"> <tr><td>C</td></tr> <tr><td>D</td></tr> </table>	C	D	
C							
D							
8	FRAME OUTER CHORD WEB INNER CHORD	0.063 0.063	BAC1506-3359 2024-T42 CLAD 7075-T6 CLAD 7075-T6				
9	FRAME OUTER CHORD INNER CHORD	0.063	BAC1506-3360 2024-T42 CLAD 7075-T6				
10	FRAME OUTER CHORD WEB	0.063	BAC1506-3359 2024-T42 CLAD 7075-T6				
11	FRAME OUTER CHORD WEB	0.063	BAC1506-3360 2024-T42 CLAD 7075-T6				
12	FRAME OUTER CHORD WEB	0.063	BAC1506-3159 2024-T42 CLAD 7075-T6				

LIST OF MATERIALS FOR DETAIL II

**Section 41 Frame Identification
Figure 1 (Sheet 5 of 11)**

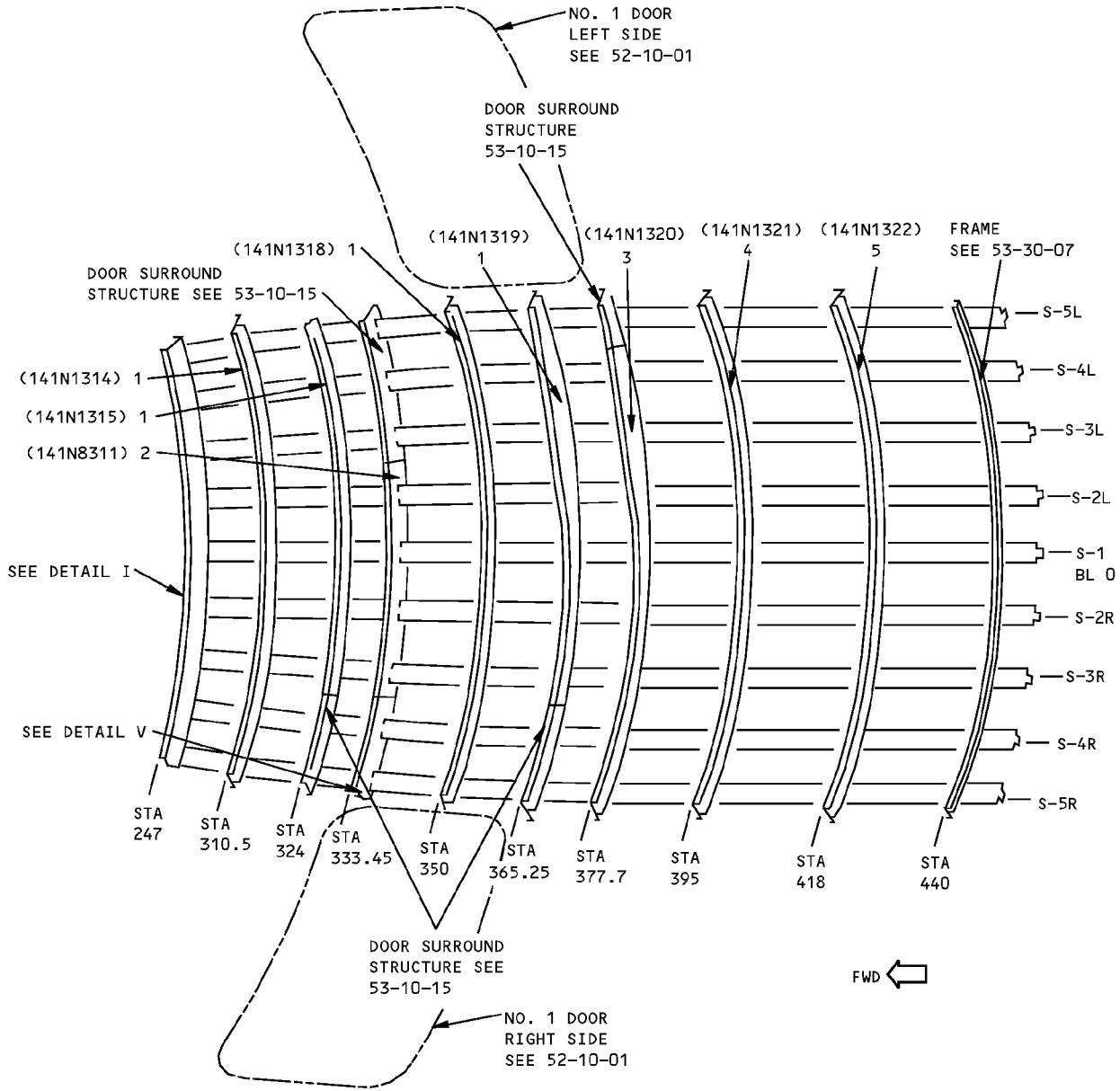
IDENTIFICATION 1
Page 5
Jan 20/2005

53-10-07

D634N201

**757-200
STRUCTURAL REPAIR MANUAL**

REF DWG
140N1510



VIEW LOOKING UP
DETAIL III



**Section 41 Frame Identification
Figure 1 (Sheet 6 of 11)**

IDENTIFICATION 1
Page 6
Jan 20/2005

53-10-07

D634N201



757-200
STRUCTURAL REPAIR MANUAL

ITEM	DESCRIPTION	GAGE	MATERIAL	EFFECTIVITY
1	FRAME FAILSAFE CHORD WEB	0.045	BAC1490-2829 CLAD 7075-T6 CLAD 7075-T6	
2	FRAME FAILSAFE CHORD WEB	0.045	BAC1490-2509 CLAD 2024-T42 CLAD 2024-T42	
3	FRAME FAILSAFE CHORD WEB	0.050	BAC1490-2829 CLAD 7075-T6 CLAD 7075-T6	
4	FRAME FAILSAFE CHORD WEB	0.045	BAC1490-2836 CLAD 7075-T6 CLAD 7075-T6	
5	FRAME FAILSAFE CHORD WEB	0.050	BAC1490-2773 CLAD 7075-T6 CLAD 7075-T6	

LIST OF MATERIALS FOR DETAIL III

Section 41 Frame Identification
Figure 1 (Sheet 7 of 11)

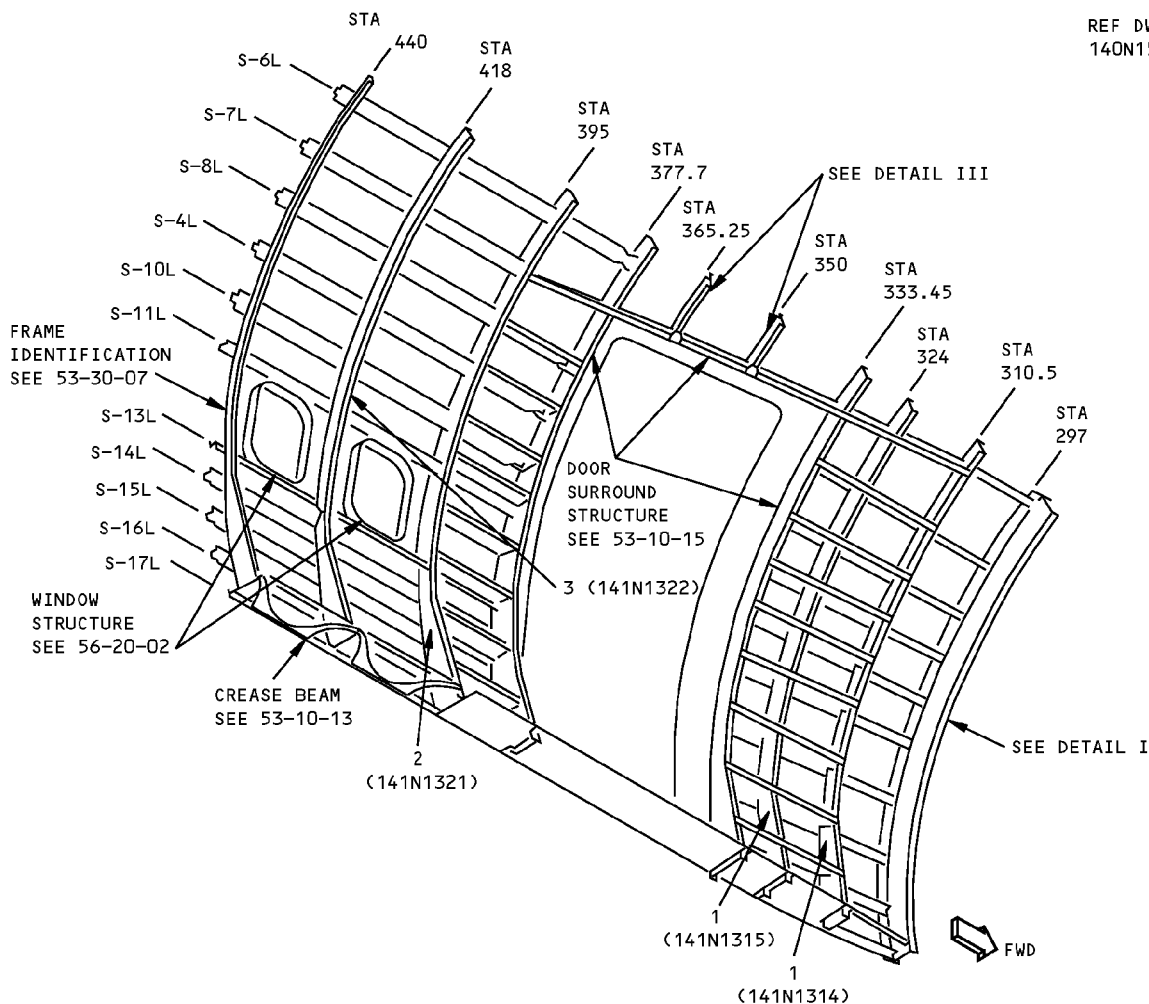
D634N201

53-10-07

IDENTIFICATION 1
Page 7
Jan 20/2005

757-200 STRUCTURAL REPAIR MANUAL

REF DWG
140N1510



DETAIL IV

ITEM	DESCRIPTION	GAGE	MATERIAL	EFFECTIVITY
1	FRAME FAILSAFE CHORD WEB	0.045	BAC1490-2829 CLAD 7075-T6 CLAD 7075-T6	
2	FRAME FAILSAFE CHORD WEB	0.045	BAC1490-2836 CLAD 7075-T6 CLAD 7075-T6	
3	FRAME FAILSAFE CHORD WEB	0.050	BAC1490-2773 CLAD 7075-T6 CLAD 7075-T6	

LIST OF MATERIALS FOR DETAIL IV

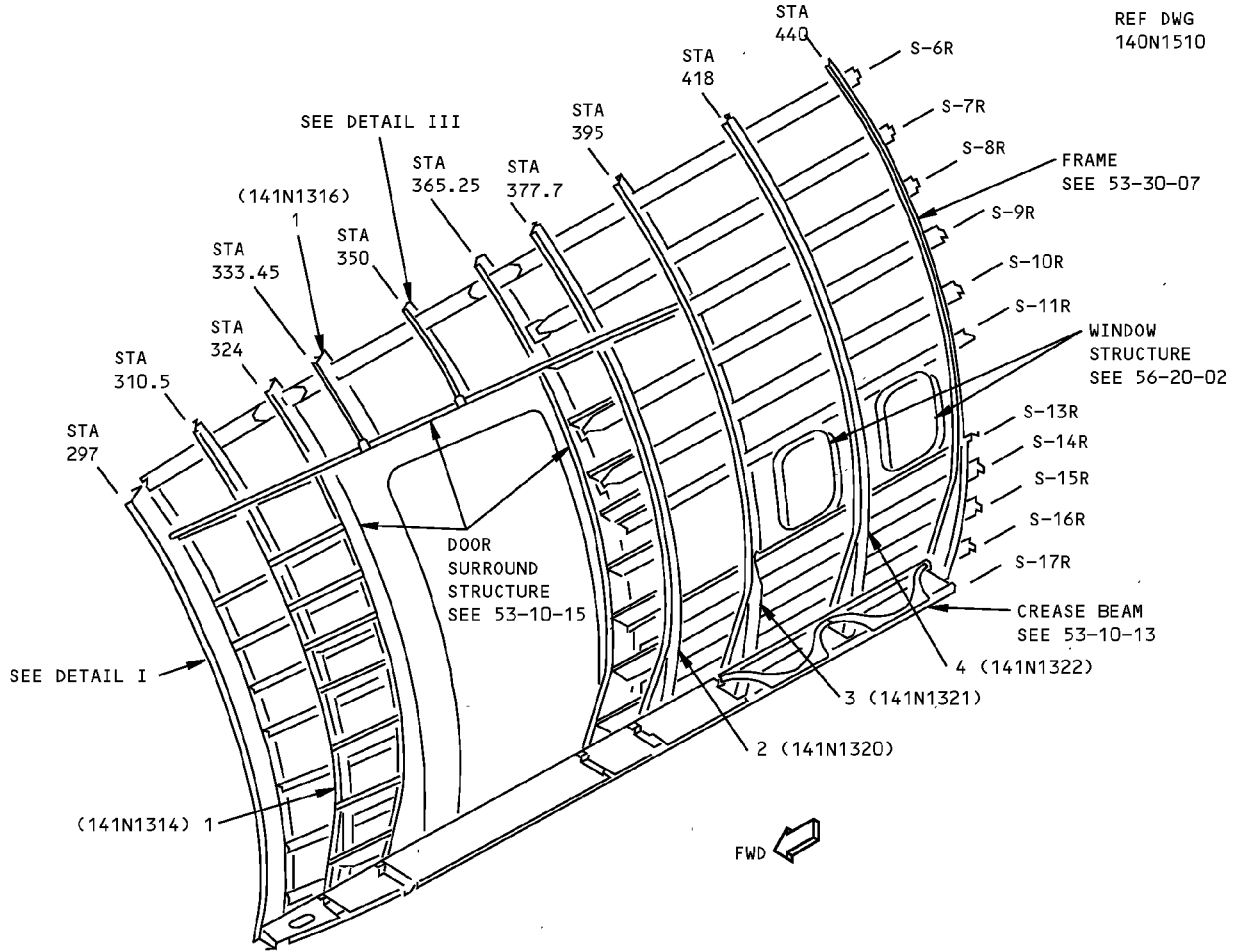
**Section 41 Frame Identification
Figure 1 (Sheet 8 of 11)**

IDENTIFICATION 1
Page 8
Jan 20/2005

53-10-07

D634N201

**757-200
STRUCTURAL REPAIR MANUAL**



DETAIL V

ITEM	DESCRIPTION	GAGE	MATERIAL		EFFECTIVITY
1	FRAME FAILSAFE CHORD WEB	0.045	BAC1490-2829 CLAD 7075-T6	CLAD 7075-T6	
2	FRAME FAILSAFE CHORD WEB	0.050	BAC1490-2829 CLAD 7075-T6	CLAD 7075-T6	
3	FRAME FAILSAFE CHORD WEB	0.045	BAC1490-2836 CLAD 7075-T6	CLAD 7075-T6	
4	FRAME FAILSAFE CHORD WEB	0.050	BAC1490-2773 CLAD 7075-T6	CLAD 7075-T6	

LIST OF MATERIALS FOR DETAIL V

**Section 41 Frame Identification
Figure 1 (Sheet 9 of 11)**

IDENTIFICATION 1

Page 9

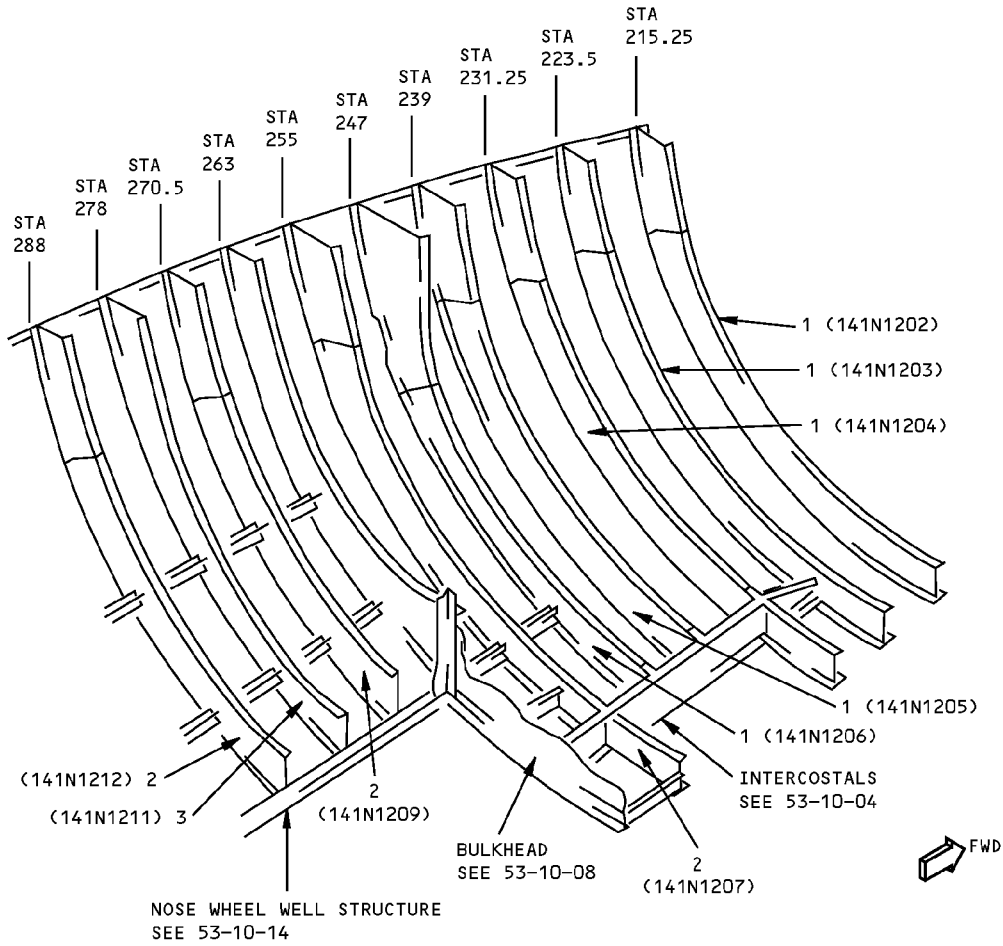
Jan 20/2005

53-10-07

D634N201

**757-200
STRUCTURAL REPAIR MANUAL**

REF DWG
140N1510



LEFT SIDE SHOWN
RIGHT SIDE OPPOSITE
DETAIL VI

ITEM	DESCRIPTION	GAGE	MATERIAL	EFFECTIVITY
1	FRAME OUTER CHORD WEB	0.045	BAC1506-3160 2024-T42 CLAD 7075-T6	
2	FRAME OUTER CHORD WEB	0.045	BAC1506-3161 2024-T42 CLAD 7075-T6	
3	FRAME OUTER CHORD WEB	0.063	BAC1506-3161 2024-T42 CLAD 7075-T6	

LIST OF MATERIALS FOR DETAIL VI

**Section 41 Frame Identification
Figure 1 (Sheet 10 of 11)**

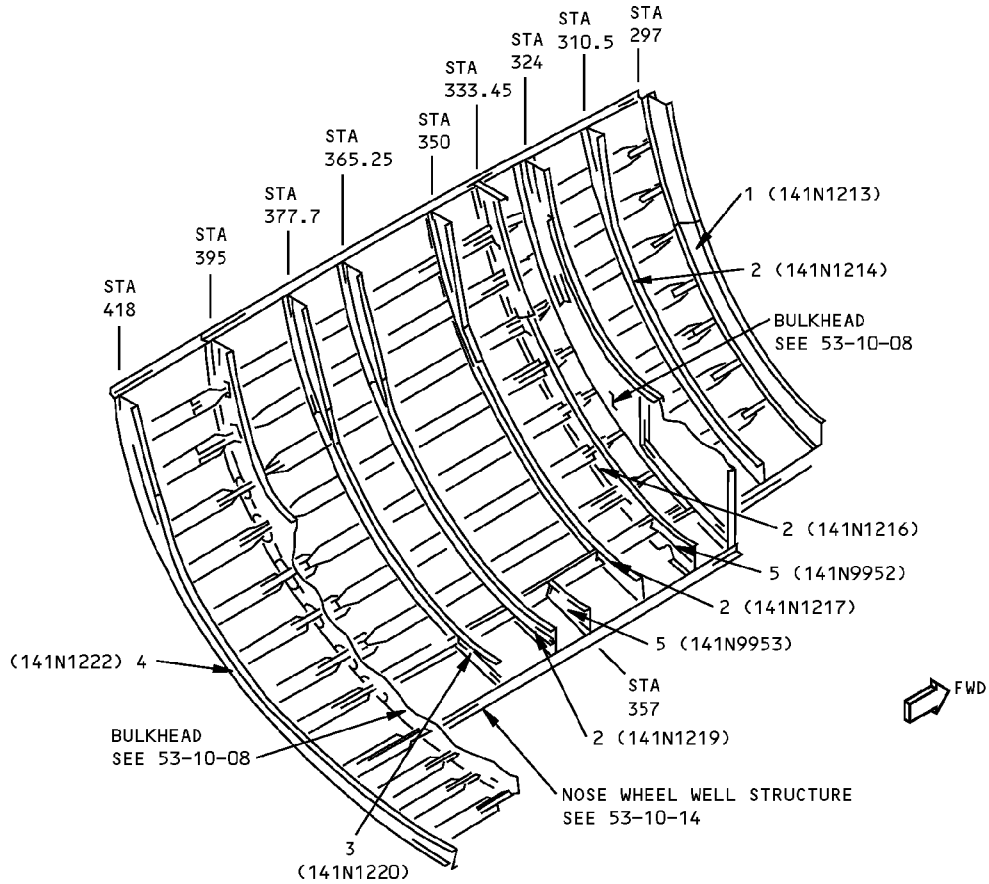
IDENTIFICATION 1
Page 10
Jan 20/2005

53-10-07

D634N201

**757-200
STRUCTURAL REPAIR MANUAL**

REF DWG
140N1510



LEFT SIDE SHOWN
RIGHT SIDE OPPOSITE
DETAIL VII

ITEM	DESCRIPTION	GAGE	MATERIAL	EFFECTIVITY
1	FRAME WEB LOWER CHORD	0.050	CLAD 7075-T6 BAC1506-3161 2024-T42	
2	FRAME FAILSAFE CHORD WEB	0.045	BAC1490-2829 CLAD 7075-T6 CLAD 7075-T6	
3	FRAME FAILSAFE CHORD WEB	0.050	BAC1490-2829 CLAD 7075-T6 CLAD 7075-T6	
4	FRAME FAILSAFE CHORD WEB	0.050	BAC1490-2773 CALD 7075-T6 CLAD 7075-T6	
5	STUB FRAME	0.063	2024-T3	

LIST OF MATERIALS FOR DETAIL VII

**Section 41 Frame Identification
Figure 1 (Sheet 11 of 11)**

IDENTIFICATION 1
Page 11
Jan 20/2005

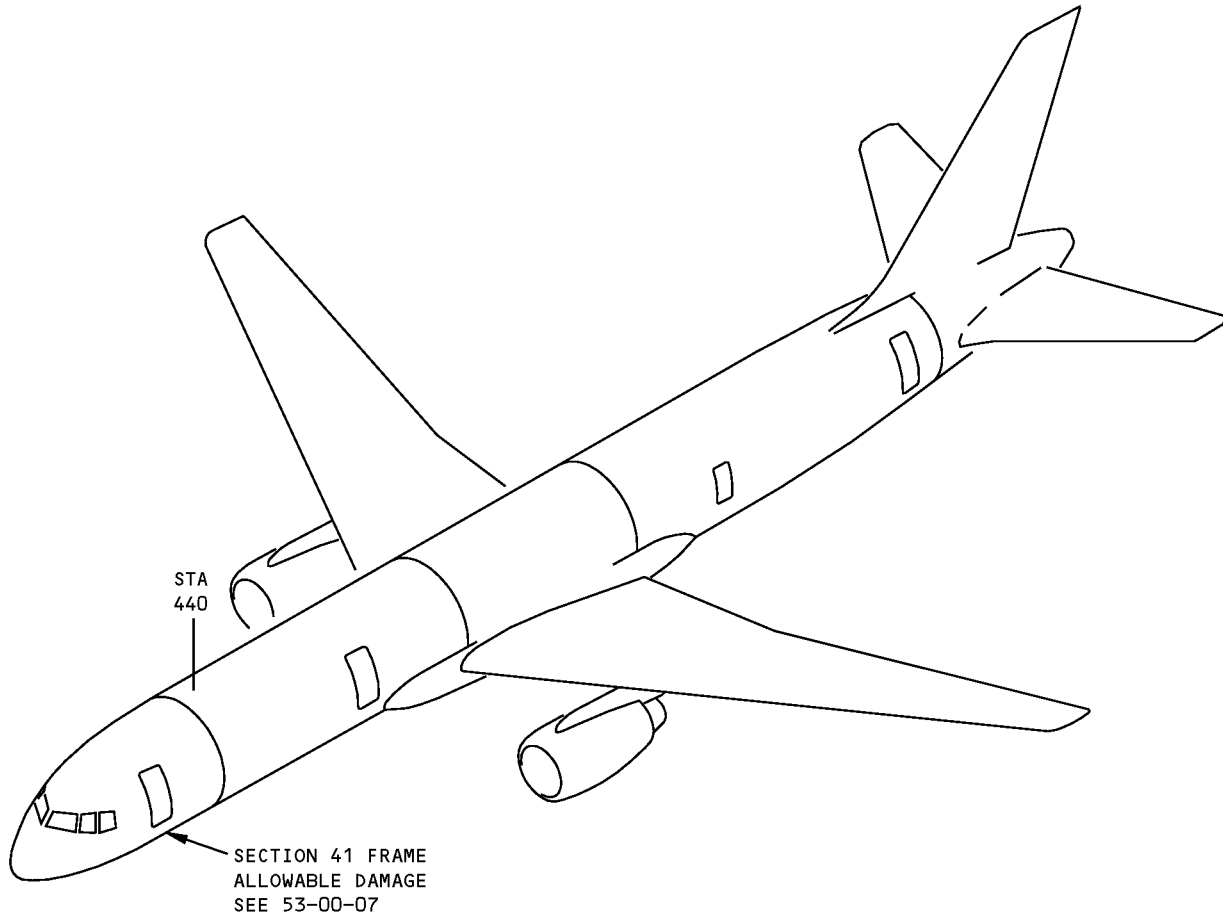
53-10-07

D634N201



757-200
STRUCTURAL REPAIR MANUAL

ALLOWABLE DAMAGE GENERAL - SECTION 41 - FRAMES

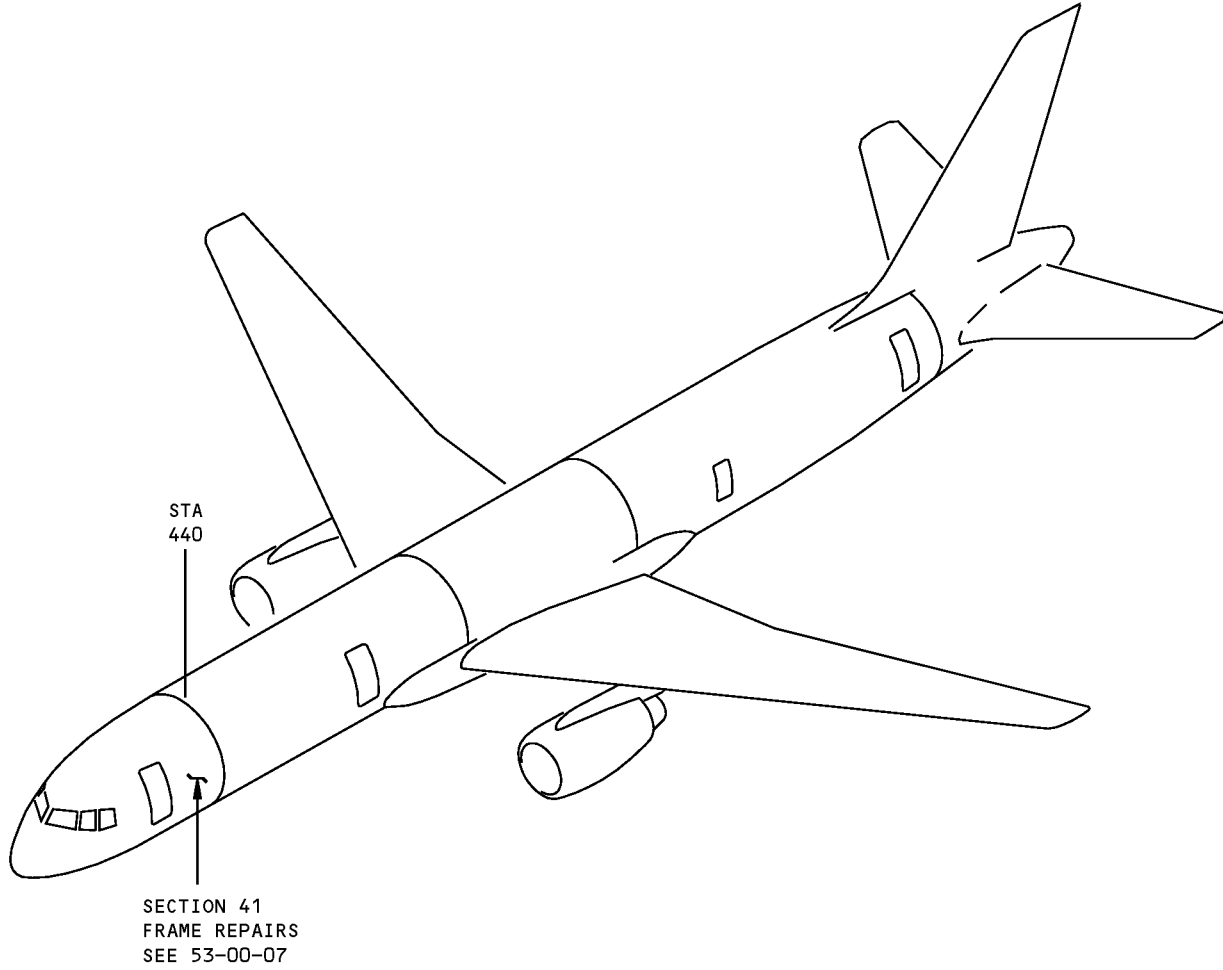


Section 41 Frame Allowable Damage
Figure 101



757-200
STRUCTURAL REPAIR MANUAL

REPAIR GENERAL - SECTION 41 - FRAMES



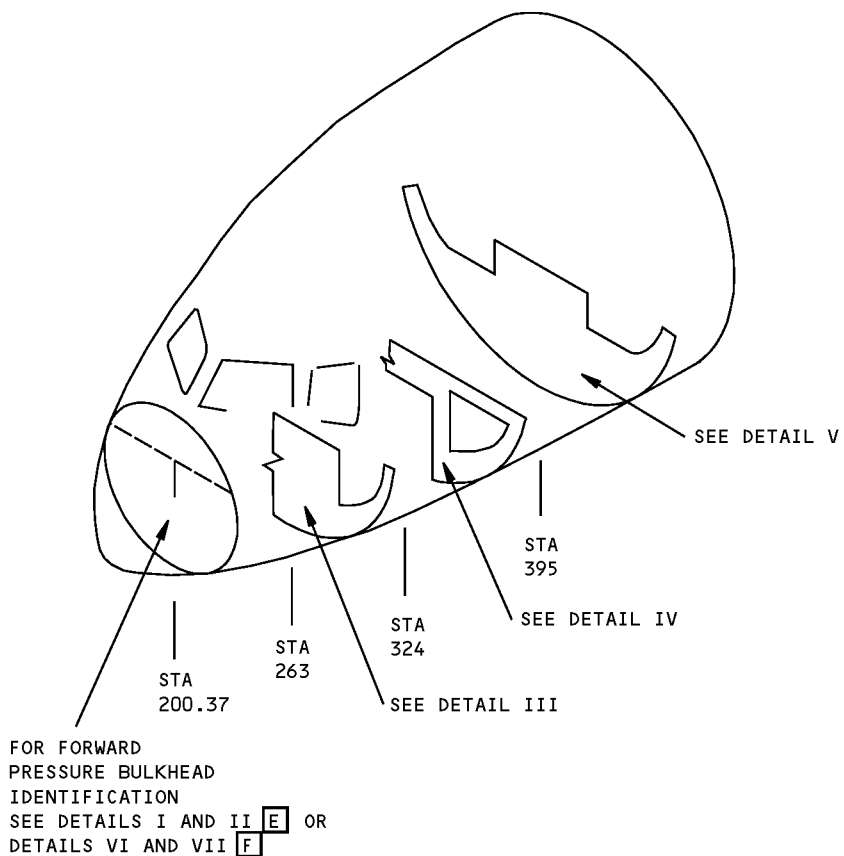
Section 41 Frame Repair
Figure 201

D634N201

REPAIR GENERAL
Page 201
53-10-07
Jan 20/2005

**757-200
STRUCTURAL REPAIR MANUAL**

IDENTIFICATION 1 - SECTION 41 - BULKHEADS



NOTES

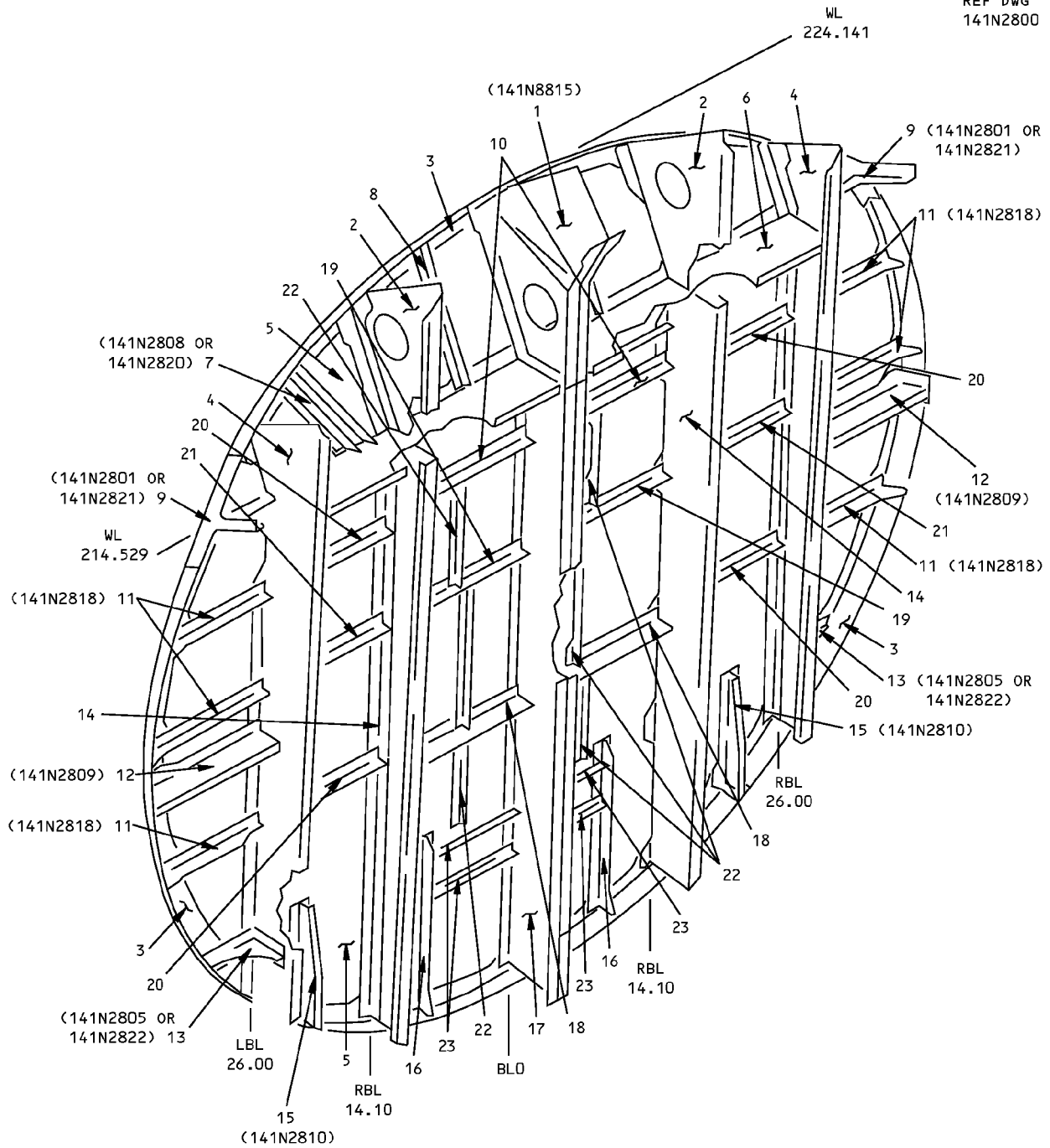
- A** FOR CUM LINE NUMBERS:
1 THRU 50
- B** FOR CUM LINE NUMBERS:
51 AND ON
- C** FOR CUM LINE NUMBERS:
1 THRU 174

- D** FOR CUM LINE NUMBERS:
175 AND ON
- E** FOR CUM LINE NUMBERS:
1 THRU 803
- F** FOR CUM LINE NUMBERS:
804 AND ON

**Section 41 Bulkhead Identification
Figure 1 (Sheet 1 of 12)**

**757-200
STRUCTURAL REPAIR MANUAL**

REF DWG
141N2800



BULKHEAD STA 200.37
REAR VIEW
DETAIL I E



**Section 41 Bulkhead Identification
Figure 1 (Sheet 2 of 12)**

IDENTIFICATION 1
Page 2
Jan 20/2005

53-10-08

D634N201



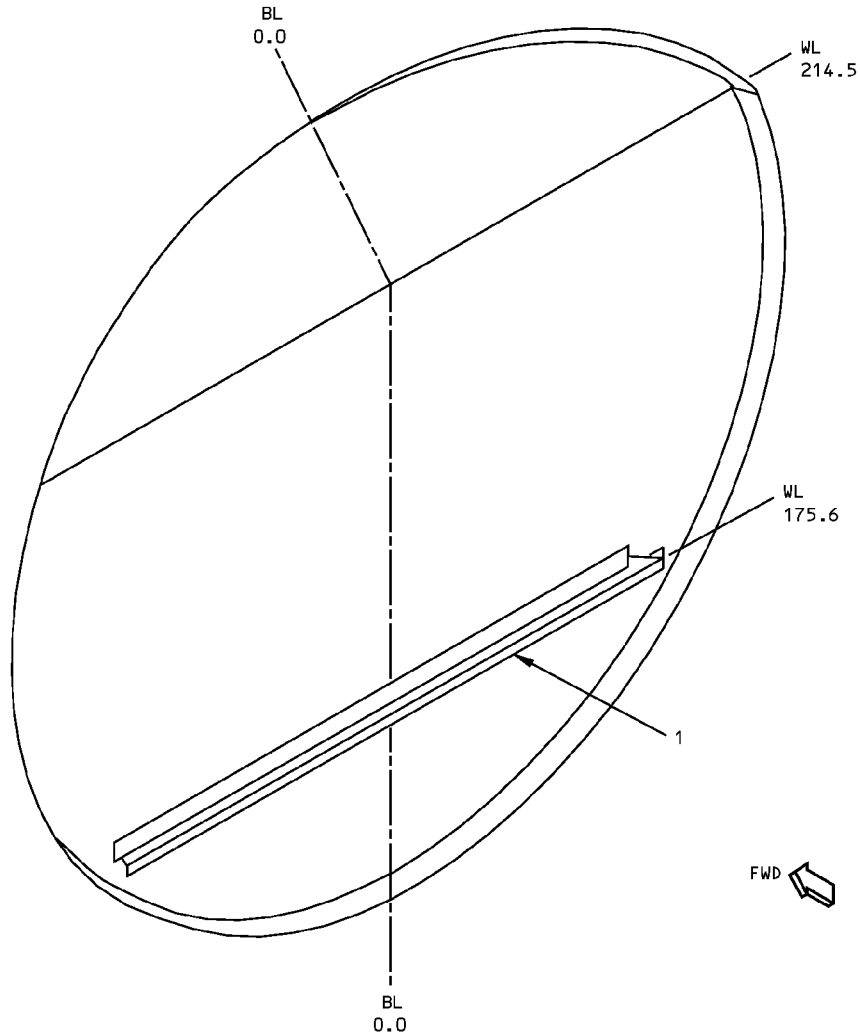
**757-200
STRUCTURAL REPAIR MANUAL**

ITEM	DESCRIPTION	GAGE	MATERIAL	EFFECTIVITY
1	SPLICE FTG		FORGED BLOCK 7075-T75	
2	PAN	0.08	CLAD 7075-T6	
3	CHORD	0.09	CLAD 2024-T42	
4	WEB	0.08	CLAD 7075-T6	
5	WEB, CHEM-MILLED	0.10	2024-T3	
6	TEE, BEAM CHORD		BAC1506-3382 2024-T3511	
7	BACK-UP FITTING		7075-T73 FORGING OR 7075-T73 FORGED BLOCK	
8	STIFFENER		AND10134-1206 2024-T3511	
9	CORNER FITTING		7075-T73 FORGING OR 7075-T73 FORGED BLOCK	
10	TEE		AND10136-2402 2024-T3511	
11	FITTING		BAC1505-100895 2025-T3511	
12	FITTING		FORGED BLOCK 7075-T73	
13	BACK-UP FITTING		7075-T73 FORGING OR 7075-T73 FORGED BLOCK	
14	WEB	0.08	CLAD 7075-T6	
15	FITTING		FORGED BLOCK 7075-T73	
16	TEE		AND10136-2407 2024-T3511	
17	BEAM ASSY		BAC1506-3129 2024-T3511 BAC1509-100553 2024-T3511	C D
18	TEE		AND10136-2408 2024-T3511	
19	TEE		BAC1505-100952 2024-T3511	
20	TEE		AND10136-2402 2024-T3511	
21	TEE		BAC1505-100952 2024-T3511	
22	TEE		AND10136-1702 2024-T3511	
23	ANGLE		AND10133-1002 2021-T3511	

LIST OF MATERIALS FOR DETAIL I E

**Section 41 Bulkhead Identification
Figure 1 (Sheet 3 of 12)**

**757-200
STRUCTURAL REPAIR MANUAL**



**BULKHEAD STA 200.37
FORWARD VIEW
DETAIL II [E]**

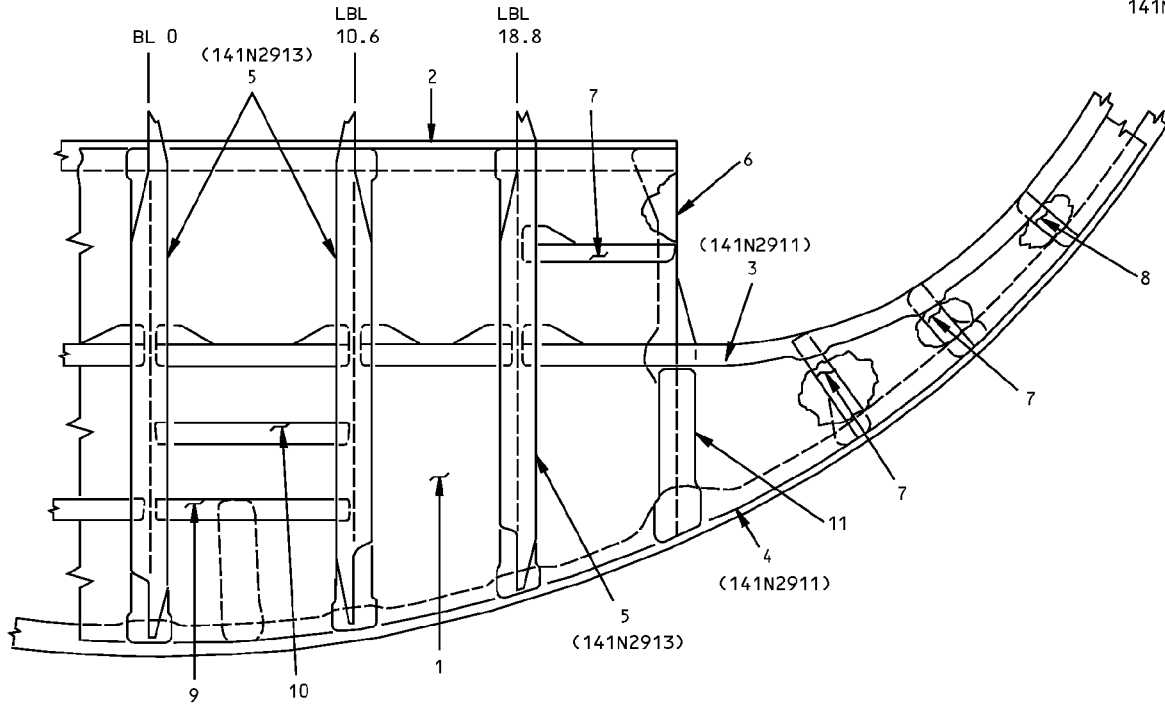
ITEM	DESCRIPTION	GAGE	MATERIAL	EFFECTIVITY
1	BEAM		AND10140-2402 2024-T3511	

LIST OF MATERIALS FOR DETAIL II [E]

**Section 41 Bulkhead Identification
Figure 1 (Sheet 4 of 12)**

**757-200
STRUCTURAL REPAIR MANUAL**

REF DWG
141N2910



**BULKHEAD STA 263
FRONT VIEW
DETAIL III**

ITEM	DESCRIPTION	GAGE	MATERIAL	EFFECTIVITY		
1	WEB	0.090	2024-T3 CHEM MILLED	<table border="1"> <tr> <td>E</td> </tr> <tr> <td>F</td> </tr> </table>	E	F
E						
F						
2	UPPER CHORD		BAC1503-100667 2024-T3511			
3	INNER CHORD		AND10136-3004 7075-T6 AND10136-3004 2024-T3511			
4	OUTER CHORD		BAC1505-101203 2024-T42			
5	BEAM		BAC1518-922 OR BAC1518-830 OR BAC1518-514 7075-T6511			
6	CHORD		BAC1505-100974 2024-T42			
7	STIFFENER		BAC1505-100052 7075-T6511			
8	STIFFENER		AND10134-1005 7075-T6511			
9	STIFFENER		AND10134-1407 7075-T6511			
10	STIFFENER		AND10133-1002 7075-T6511			
11	SPLICE PLATE	0.090	CLAD 2024-T3			

LIST OF MATERIALS FOR DETAIL III

**Section 41 Bulkhead Identification
Figure 1 (Sheet 5 of 12)**

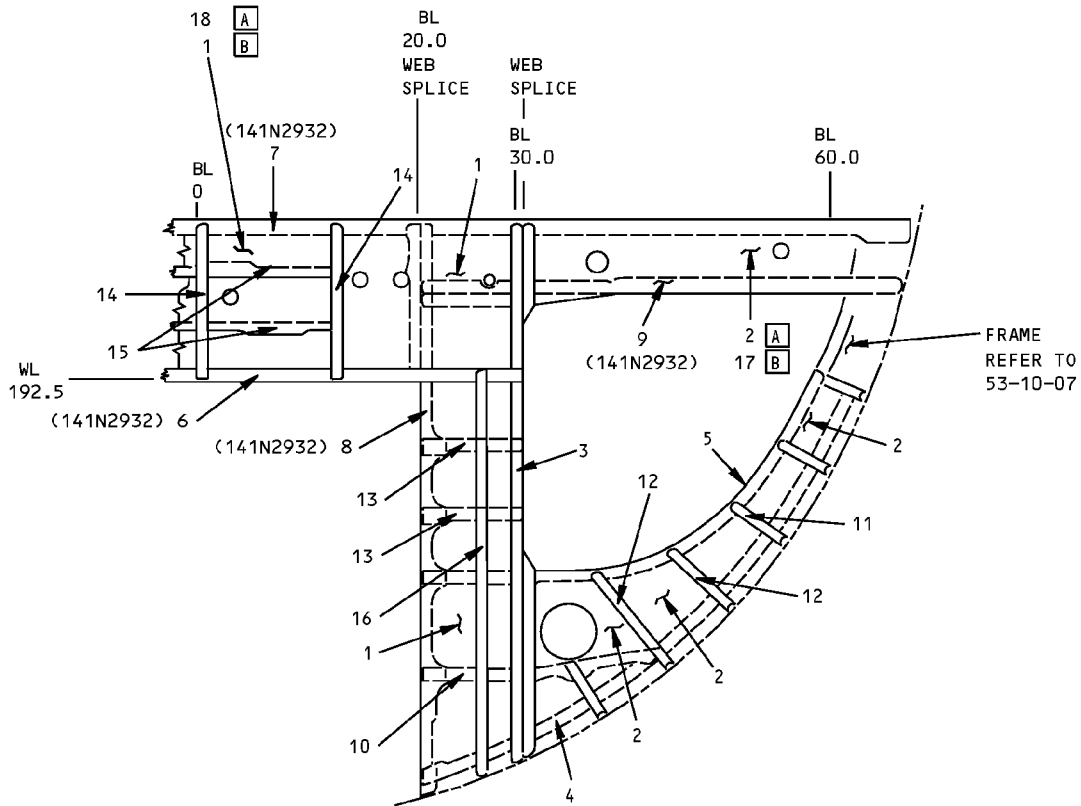
IDENTIFICATION 1
Page 5
Jan 20/2005

53-10-08

D634N201

**757-200
STRUCTURAL REPAIR MANUAL**

REF DWG
141N2930



FRONT VIEW
BULKHEAD STA 324
DETAIL IV



**Section 41 Bulkhead Identification
Figure 1 (Sheet 6 of 12)**

IDENTIFICATION 1
Page 6
Jan 20/2005

53-10-08

D634N201



757-200
STRUCTURAL REPAIR MANUAL

ITEM	DESCRIPTION	GAGE	MATERIAL	EFFECTIVITY
1	WEB	0.08	2024-T3 CHEM MILLED	
2	WEB	0.063	2024-T3 CHEM MILLED	
3	STIFFENER		BAC1505-101094 2024-T42	
4	CHORD		AND10136-2401 7075-T6	
5	CHORD		AND10133-1402 7075-T6	
6	CHORD		BAC1506-3297 2024-T42	
7	CHORD		AND10136-2409 7075-T6511	
8	CHORD		BAC1505-100605 2024-T42 OPTIONAL BAC1505-101207 2024-T42	
9	CHORD		AND10136-3004 7075-T6511	
10	STIFFENER		BAC1503-2811 7075-T6	
11	STIFFENER		BAC1518-720 7075-T6511	
12	STIFFENER		BAC1518-716 7075-T6511	
13	STIFFENER		AND10134-1404 7075-T6	
14	STIFFENER		AND10134-1202 7075-T6	
15	STIFFENER		AND10134-1201 7075-T6511	
16	STIFFENER		AND10133-2401 2024-T42	
17	WEB	0.125	2024-T3 CHEM MILLED	
18	WEB	0.190	2024-T3 CHEM MILLED	

LIST OF MATERIALS FOR DETAIL IV

Section 41 Bulkhead Identification
Figure 1 (Sheet 7 of 12)

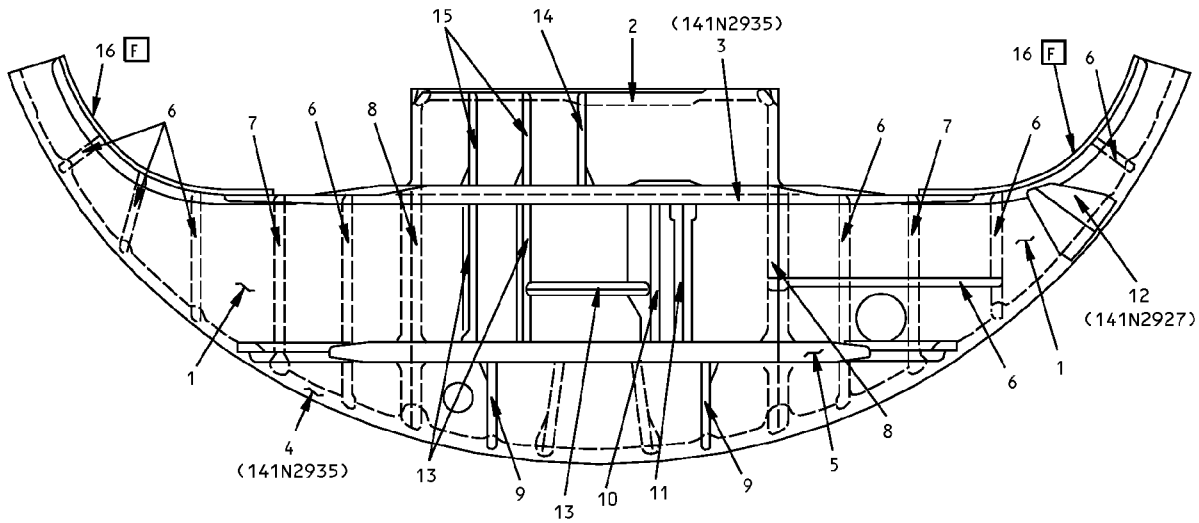
D634N201

53-10-08

IDENTIFICATION 1
Page 7
Jan 20/2005

**757-200
STRUCTURAL REPAIR MANUAL**

REF DWG
141N2920



**BULKHEAD STA 395
REAR VIEW
DETAIL V**



**Section 41 Bulkhead Identification
Figure 1 (Sheet 8 of 12)**

IDENTIFICATION 1
Page 8
Jan 20/2005

53-10-08

D634N201



**757-200
STRUCTURAL REPAIR MANUAL**

ITEM	DESCRIPTION	GAGE	MATERIAL	EFFECTIVITY
1	WEB	0.125	2024-T3	
2	BEAM		BAC1503-100669 2024-T3511	
3	INNER CHORD		BAC1518-787 7075-T6	
4	OUTER CHORD		BAC1505-101207 2024-T42	
5	BEAM		BAC1509-100472 2024-T3511	
6	STIFFENER		AND10134-1206 2024-T42	
7	STIFFENER		AND10134-2001 2024-T42	
8	TEE SUPPORT		BAC1505-101207 2024-T3511	
9	STIFFENER		AND10136-2003 2024-T42	
10	TEE SUPPORT		BAC1505-100605 2024-T42 OR BAC1505-101207 2024-T42	
11	TEE SUPPORT		AND10136-3001 2024-T42	
12	JACKING SUPPORT FITTING		FORGING 7075-T73	
13	STIFFENER		BAC1506-2400 2024-T42	
14	TEE SUPPORT		AND10136-2402 2024-T42	
15	TEE SUPPORT		AND10136-2003 2024-T42	
16	STABILIZATION STRAP	0.150	7075-T73	F

LIST OF MATERIALS FOR DETAIL V

**Section 41 Bulkhead Identification
Figure 1 (Sheet 9 of 12)**

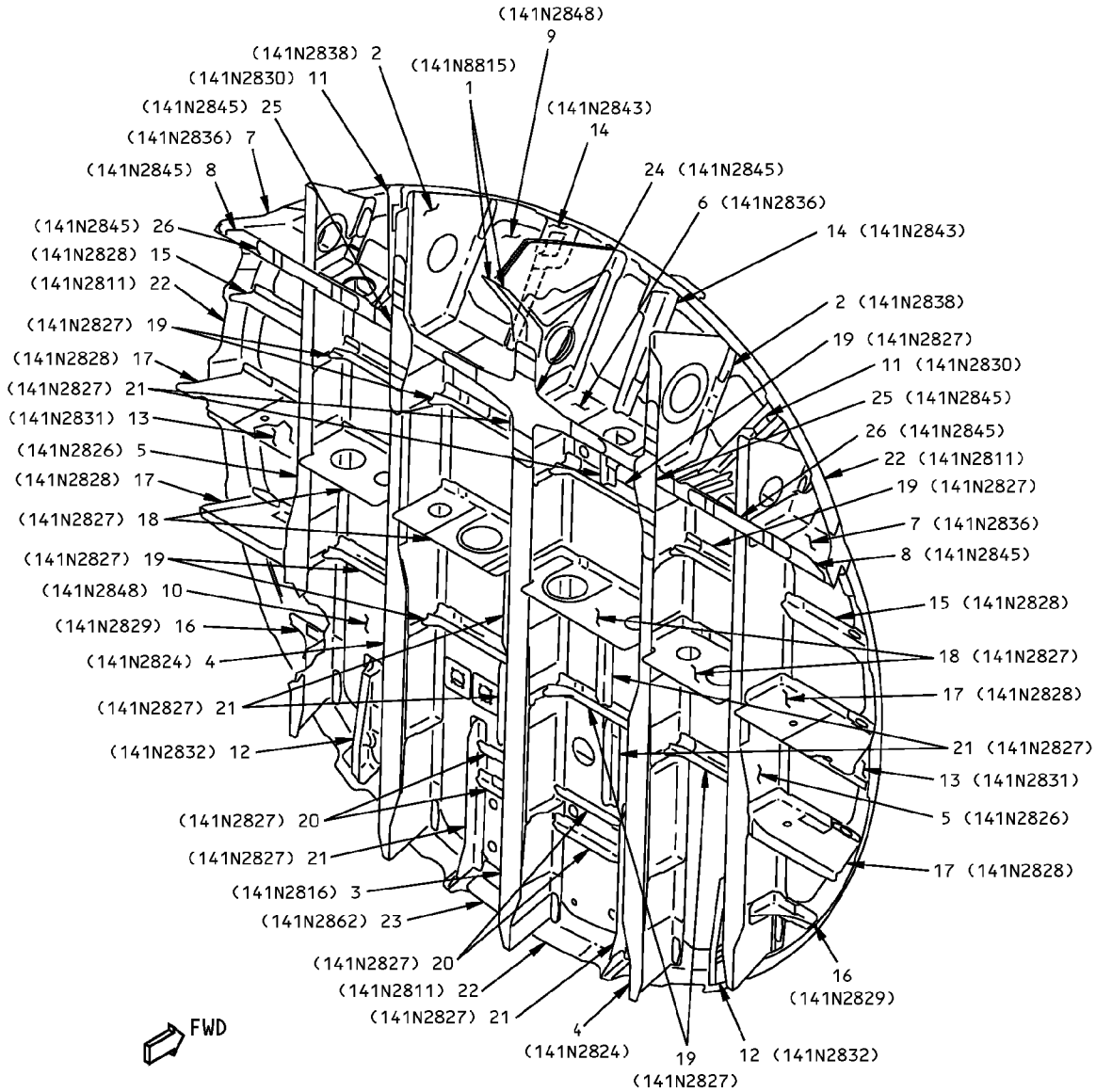
IDENTIFICATION 1
Page 9
Jan 20/2005

53-10-08

D634N201

**757-200
STRUCTURAL REPAIR MANUAL**

REFERENCE DRAWING
141N2807



BULKHEAD STATION 200.37
REAR VIEW
DETAIL VI E

**Section 41 Bulkhead Identification
Figure 1 (Sheet 10 of 12)**

IDENTIFICATION 1
Page 10
Jan 20/2005

53-10-08

D634N201



**757-200
STRUCTURAL REPAIR MANUAL**

ITEM	DESCRIPTION	GAGE	MATERIAL	EFFECTIVITY
1	SPLICE FITTING		7050-T7451	
2	PAN FITTING		7050-T7451	
3	BEAM		7050-T7451	
4	BEAM		7050-T7451	
5	BEAM		7050-T7451	
6	SILL BEAM		7050-T7451	
7	SILL END FITTING		7050-T7451	
8	SILL ANGLE FITTING		7050-T7451	
9	WEB	0.180	2024-T3 (CHEM-MILLED TO 0.100 MINIMUM)	
10	WEB	0.180	2024-T3 (CHEM-MILLED TO 0.060 MINIMUM)	
11	LATCH BACK-UP FITTING		7050-T7451	
12	LATCH BACK-UP FITTING		7050-T7451	
13	LATCH BACK-UP FITTING		7050-T7451	
14	HINGE FITTING		7050-T7451	
15	FITTING		7050-T7451	
16	FITTING		7050-T7451	
17	FITTING		7050-T7451	
18	STIFFENER - INTERCOSTAL		7050-T7451	
19	STIFFENER - CHANNEL		7050-T7451	
20	STIFFENER - ANGLE		7050-T7451	
21	STIFFENER - TEE		7050-T7451	
22	CHORD	0.090	CLAD 2024-T42	
23	CHORD SPLICE PLATE	0.100	CLAD 2024-T42	
24	STRAP	0.150	TI-6AL-4V	
25	STRAP	0.200	TI-6AL-4V	
26	STRAP	0.200	7075-T6	

LIST OF MATERIALS FOR DETAIL VI F

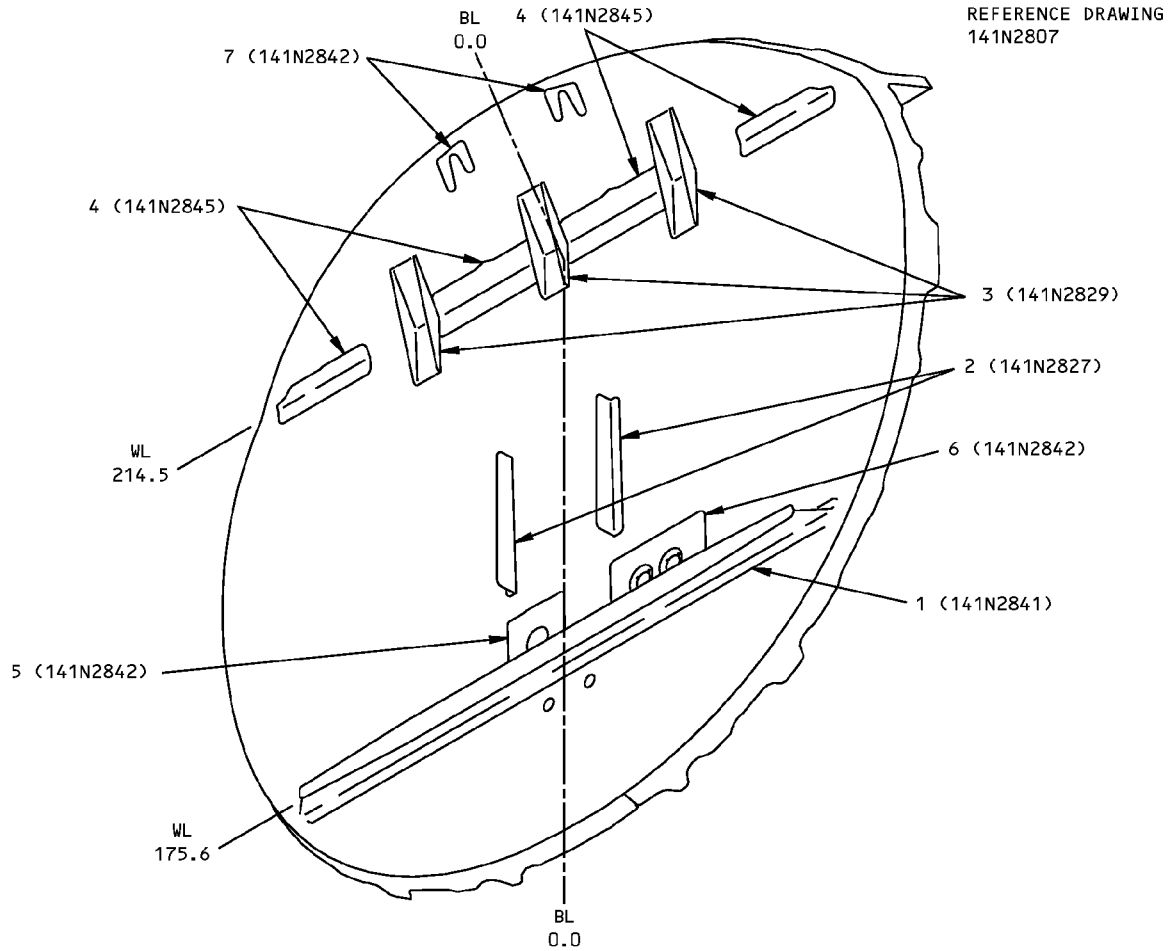
**Section 41 Bulkhead Identification
Figure 1 (Sheet 11 of 12)**

D634N201

53-10-08

IDENTIFICATION 1
Page 11
Jan 20/2005

**757-200
STRUCTURAL REPAIR MANUAL**



**BULKHEAD STA 200.37
FORWARD VIEW
DETAIL VII F**

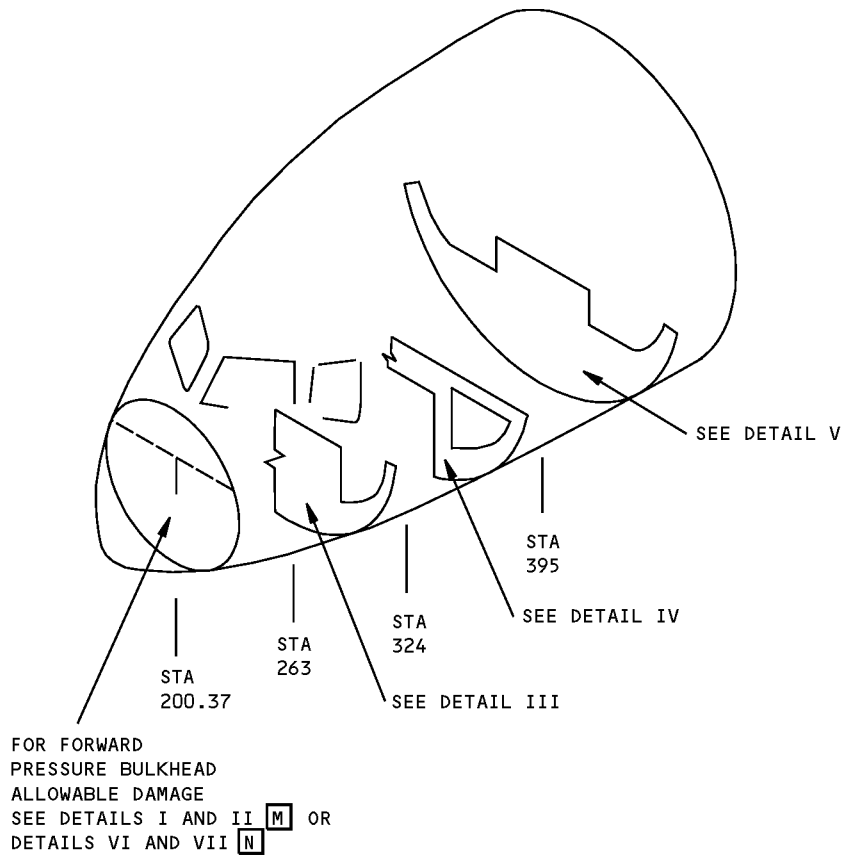
ITEM	DESCRIPTION	GAGE	MATERIAL	EFFECTIVITY
1	BEAM		7050-T7451 AS GIVEN IN BMS7-323, TYPE 1	
2	STIFFENER - ANGLE		7050-T7451 AS GIVEN IN AMS4050	
3	FITTING		7050-T7451 AS GIVEN IN BMS7-323, TYPE 1	
4	STRAP		7050-T7451 AS GIVEN IN AMS4050	
5	DOUBLER	0.063	CLAD 2024-T3	
6	DOUBLER	0.100	CLAD 2024-T3	
7	HINGE STOP BLOCK	0.125	2024-T3	

LIST OF MATERIALS FOR DETAIL VII F

**Section 41 Bulkhead Identification
Figure 1 (Sheet 12 of 12)**

**757-200
STRUCTURAL REPAIR MANUAL**

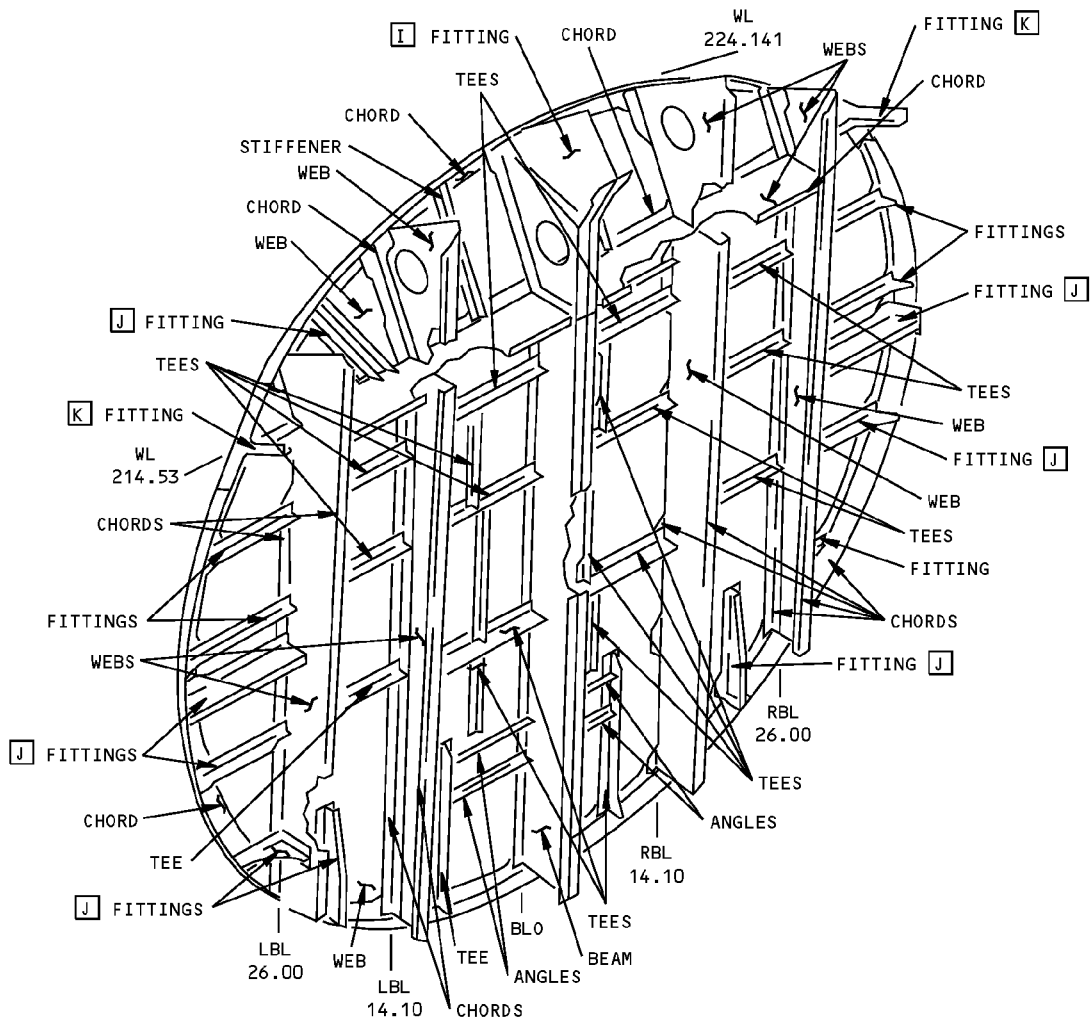
ALLOWABLE DAMAGE 1 - SECTION 41 - BULKHEADS



**Section 41 Bulkhead Allowable Damage
Figure 101 (Sheet 1 of 10)**

**757-200
STRUCTURAL REPAIR MANUAL**

REF DWG
141N2800



BULKHEAD STA 200.37
REAR VIEW
DETAIL I **M**

MATERIAL: ALUMINUM

**Section 41 Bulkhead Allowable Damage
Figure 101 (Sheet 2 of 10)**

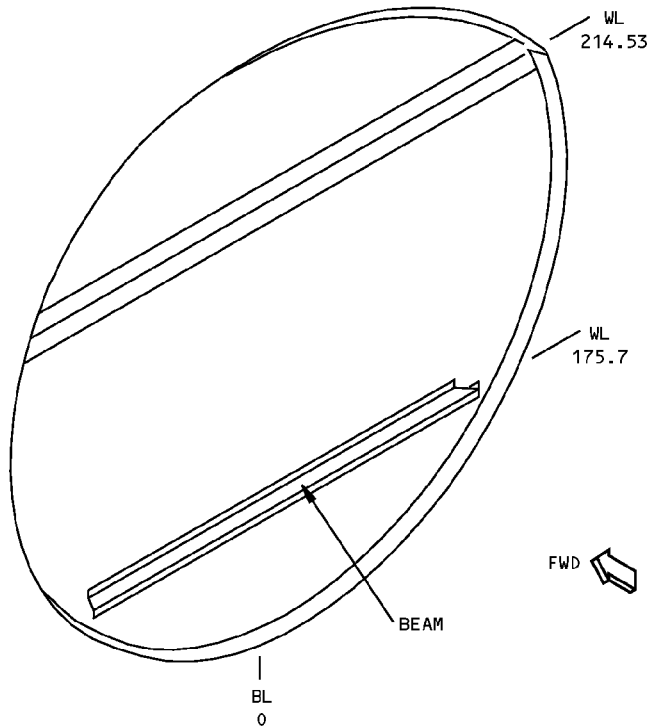
ALLOWABLE DAMAGE 1
Page 102
Jan 20/2005

53-10-08

D634N201

**757-200
STRUCTURAL REPAIR MANUAL**

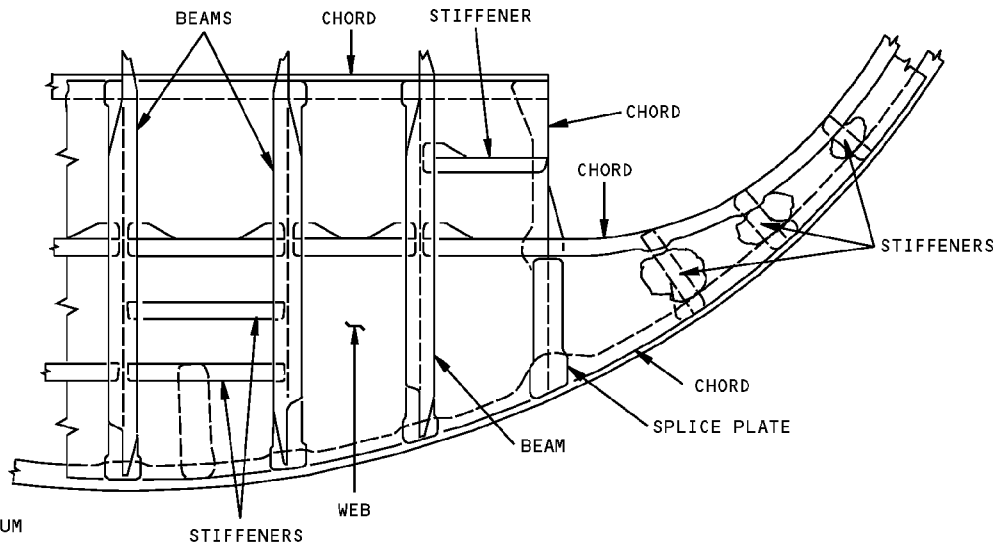
REF DWG
141N2800



MATERIAL: ALUMINUM

**BULKHEAD STA 200.37
FRONT VIEW
DETAIL II M**

REF DWG
141N2910



MATERIAL: ALUMINUM

**BULKHEAD STA 263
FRONT VIEW
DETAIL III**

**Section 41 Bulkhead Allowable Damage
Figure 101 (Sheet 3 of 10)**

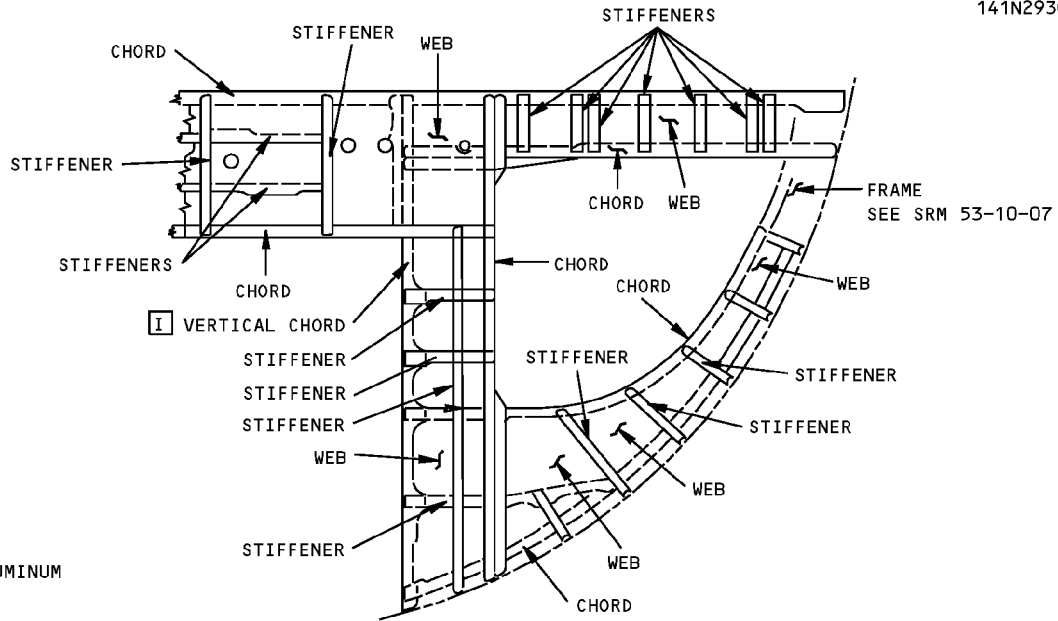
ALLOWABLE DAMAGE 1
Page 103
Jan 20/2005

53-10-08

D634N201

**757-200
STRUCTURAL REPAIR MANUAL**

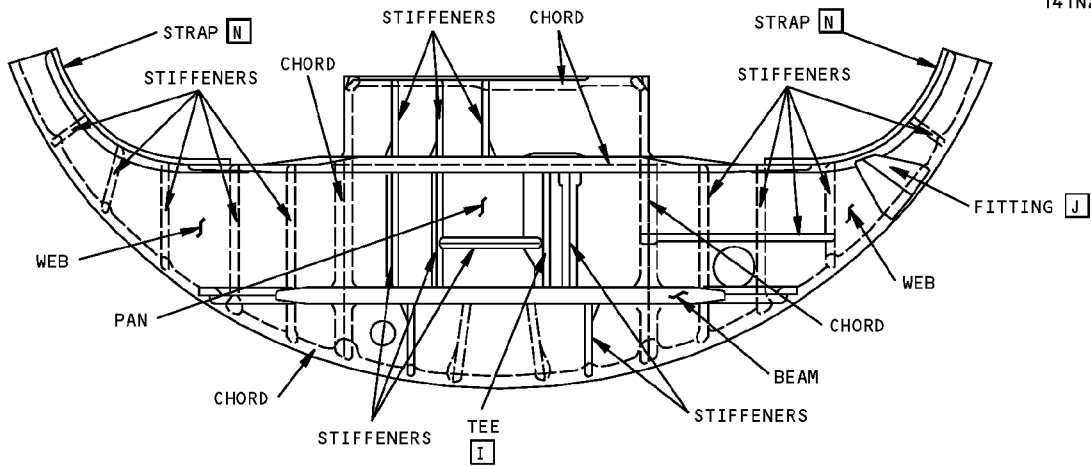
REF DWG
141N2930



MATERIAL: ALUMINUM

LEFT SIDE SHOWN
RIGHT SIDE SIMILAR
BULKHEAD STA 324
DETAIL IV

REF DWG
141N2920



MATERIAL: ALUMINUM

BULKHEAD STA 395
REAR VIEW
DETAIL V

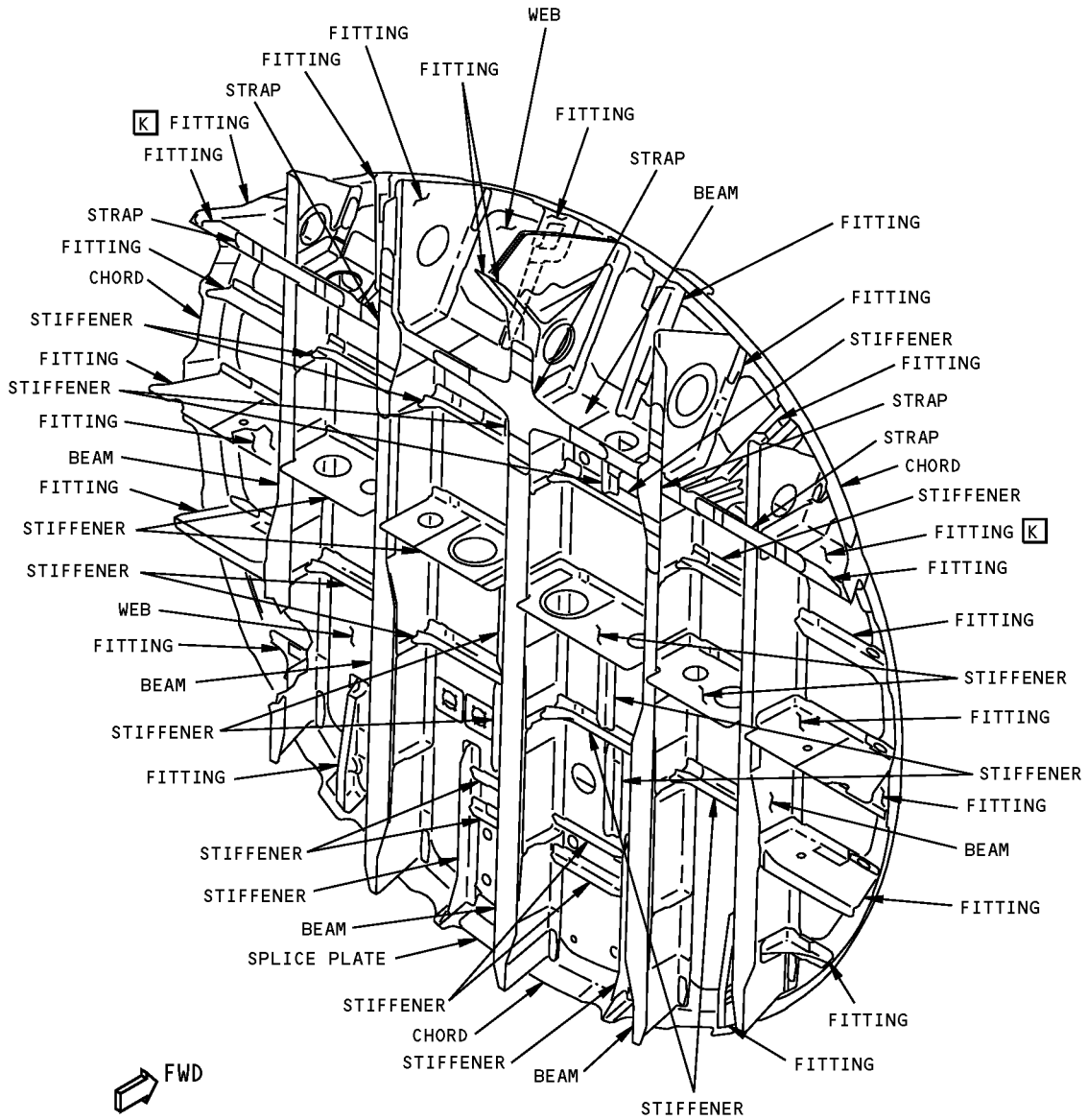
**Section 41 Bulkhead Allowable Damage
Figure 101 (Sheet 4 of 10)**

ALLOWABLE DAMAGE 1
Page 104
Jan 20/2005

53-10-08

D634N201

**757-200
STRUCTURAL REPAIR MANUAL**

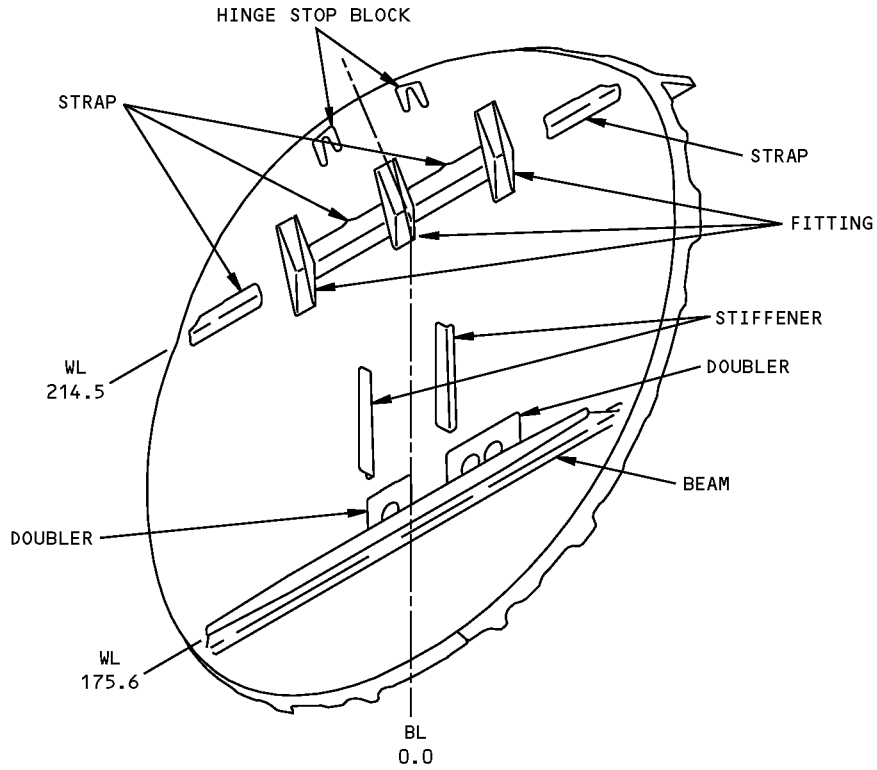


**BULKHEAD STATION 200.37
REAR VIEW
DETAIL VI N**

**Section 41 Bulkhead Allowable Damage
Figure 101 (Sheet 5 of 10)**

**757-200
STRUCTURAL REPAIR MANUAL**

REF DWG
141N2807



**BULKHEAD STA 200.37
FORWARD VIEW
DETAIL VII N**

**Section 41 Bulkhead Allowable Damage
Figure 101 (Sheet 6 of 10)**

ALLOWABLE DAMAGE 1
Page 106
Jan 20/2005

53-10-08

D634N201

**757-200
STRUCTURAL REPAIR MANUAL**

DESCRIPTION	CRACKS	NICKS, GOUGES AND CORROSION	DENTS	HOLES AND PUNCTURES
STIFFENERS	A	B	NOT PERMITTED	SEE DETAIL XIV
CHORDS	A	B	NOT PERMITTED	NOT PERMITTED
TEES	A	B	NOT PERMITTED	SEE DETAIL XIV
WEBS	C	B	SEE DETAIL X	D
PANS	C	B	NOT PERMITTED	D
FITTINGS	G	H	NOT PERMITTED	NOT PERMITTED
ANGLES	A	B	NOT PERMITTED	SEE DETAIL XIV
BEAMS	A	B	NOT PERMITTED	SEE DETAIL XIV
VERTICAL CHORD	E	F	NOT PERMITTED	NOT PERMITTED
TEE SUPPORT	E	F	NOT PERMITTED	SEE DETAIL XIV
SPLICE PLATE	A	B	NOT PERMITTED	NOT PERMITTED
STRAP N	A	B	NOT PERMITTED	NOT PERMITTED
DOUBLER N	A	B	NOT PERMITTED	NOT PERMITTED
HINGE STOP BLOCK N	A	B	NOT PERMITTED	NOT PERMITTED

NOTES

- REFINISH REWORKED AREAS AS GIVEN IN AMM 51-20.
- A** CRACKS ARE NOT PERMITTED EXCEPT FOR EDGE CRACKS WHICH MUST BE REMOVED AS GIVEN IN DETAILS VIII AND XIII
- B** REMOVE THE DAMAGE AS GIVEN IN DETAILS VIII, IX, AND XI
- C** CRACKS ARE NOT PERMITTED EXCEPT FOR EDGE CRACKS WHICH MUST BE REMOVED AS GIVEN IN DETAILS VIII AND XII
- D** CLEAN OUT THE DAMAGE UP TO A 0.25 INCH MAXIMUM DIAMETER. THE DAMAGE MUST BE A MINIMUM OF 1.0 INCH AWAY FROM A FASTENER HOLE OR OTHER DAMAGE. FILL THE HOLE WITH A 2117-T4 OR A 2117-T3 ALUMINUM PROTRUDING HEAD RIVET. MAKE SURE THERE IS SUFFICIENT FASTENER EDGE MARGIN IF THE DAMAGE IS NEAR THE EDGE OF THE PART.
- E** CRACKS ARE NOT PERMITTED EXCEPT FOR EDGE CRACKS WHICH MUST BE REMOVED AS GIVEN IN DETAILS VIII AND XIII. SEE DETAILS IV AND V FOR THE SHOT PEENING THAT IS NECESSARY.
- F** REMOVE THE DAMAGE AS GIVEN IN DETAILS VIII, IX, AND XI. SEE DETAILS IV AND V FOR THE SHOT PEENING THAT IS NECESSARY.
- G** CRACKS ARE NOT PERMITTED EXCEPT FOR EDGE CRACKS WHICH MUST BE REMOVED AS GIVEN IN DETAILS VIII AND XIII. SEE DETAILS I, V, AND VI FOR THE SHOT PEENING THAT IS NECESSARY.
- H** FOR EDGE DAMAGE, SEE DETAIL XVI. FOR LUG DAMAGE, SEE DETAIL XV. FOR OTHER DAMAGE, SEE DETAIL IX. DAMAGE IS NOT PERMITTED IN THE VICINITY OF BUSHINGS. SEE DETAILS I, V, AND VI FOR THE SHOT PEENING THAT IS NECESSARY.
- I** SHOT PEEN THE REWORKED AREA AS GIVEN IN SOPM 20-10-03 WITH SHOT NO. 230-550, INTENSITY 0.008A **L**
- J** SHOT PEEN THE REWORKED AREA AS GIVEN IN SOPM 20-10-03 WITH SHOT NO. 230-550, INTENSITY 0.006A **L**
- K** SHOT PEEN THE REWORKED AREA AS GIVEN IN SOPM 20-10-03 WITH SHOT NO. 230-550, INTENSITY 0.005A-0.010A **L**
- L** SHOT PEEN INTENSITIES ARE SHOWN FOR MANUFACTURED COMPONENTS. REFER TO SRM 51-20-06 FOR SHOT PEEN INTENSITIES THAT ARE NECESSARY FOR THICKNESSES REMAINING AFTER REWORK.
- M** FOR CUM LINE NUMBERS: 1 THRU 803
- N** FOR CUM LINE NUMBERS: 804 AND ON

**Section 41 Bulkhead Allowable Damage
Figure 101 (Sheet 7 of 10)**

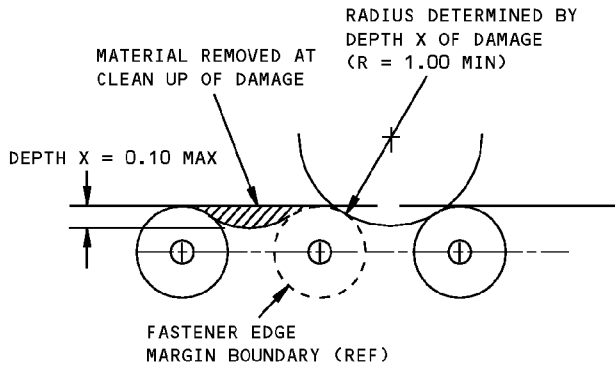
ALLOWABLE DAMAGE 1

53-10-08

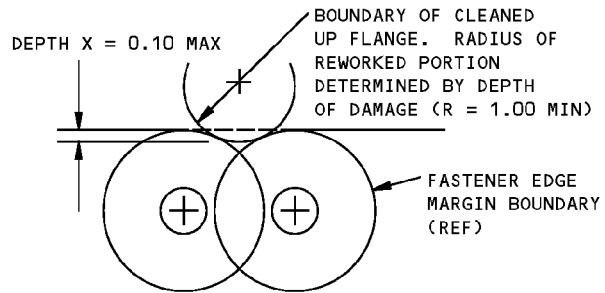
Page 107
Jan 20/2005

D634N201

**757-200
STRUCTURAL REPAIR MANUAL**

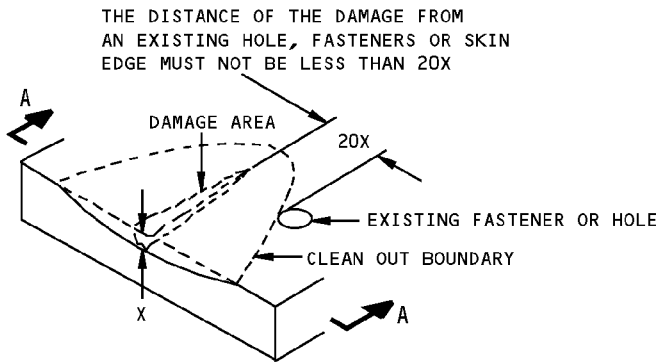


DAMAGE CLEAN UP OF EDGES WHERE FASTENER EDGE MARGINS DO NOT OVERLAP

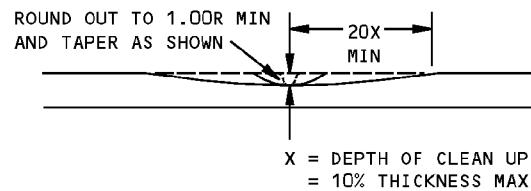


DAMAGE CLEAN UP OF EDGES WHERE FASTENER EDGE MARGINS OVERLAP

DETAIL VIII



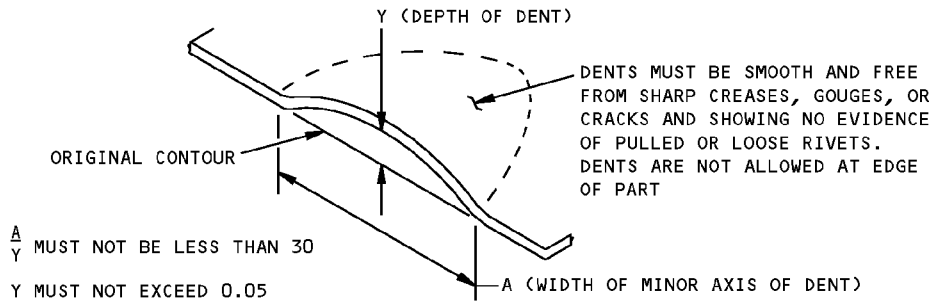
REMOVAL OF NICK, GOUGE AND SCRATCH DAMAGE ON A SURFACE
DETAIL IX



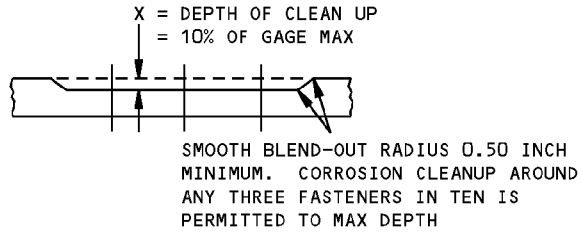
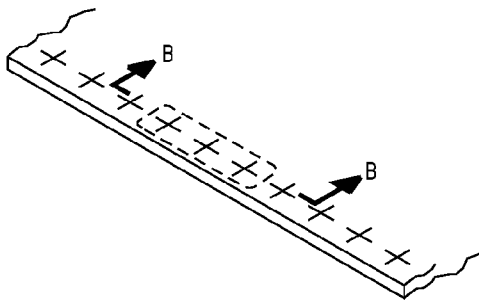
SECTION A-A

**Section 41 Bulkhead Allowable Damage
Figure 101 (Sheet 8 of 10)**

**757-200
STRUCTURAL REPAIR MANUAL**

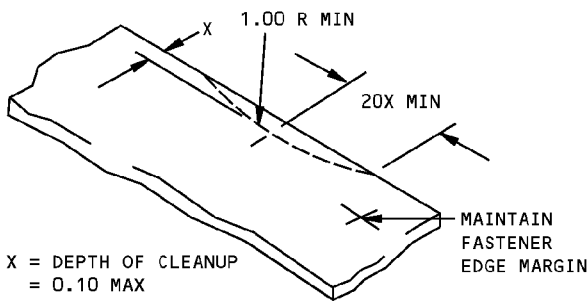


**ALLOWABLE DAMAGE FOR DENT
DETAIL X**

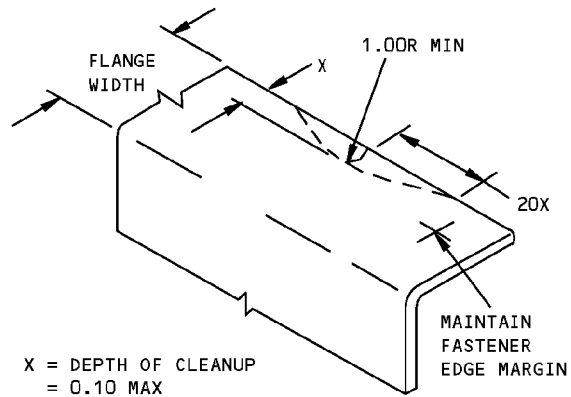


SECTION B-B

**CORROSION CLEANUP
DETAIL XI**



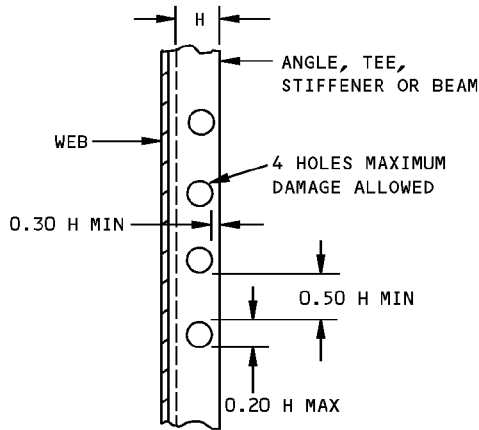
**REMOVAL OF NICK OR CRACK
DAMAGE ON AN EDGE
DETAIL XII**



**REMOVAL OF NICK OR CRACK
DAMAGE ON AN EDGE
DETAIL XIII**

**Section 41 Bulkhead Allowable Damage
Figure 101 (Sheet 9 of 10)**

**757-200
STRUCTURAL REPAIR MANUAL**

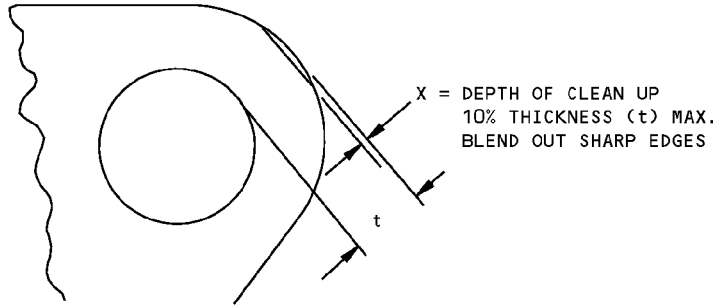


NOTE:

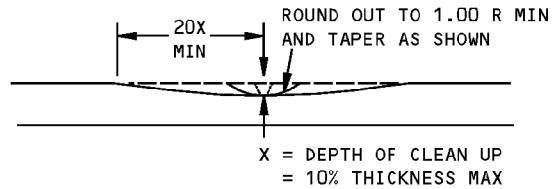
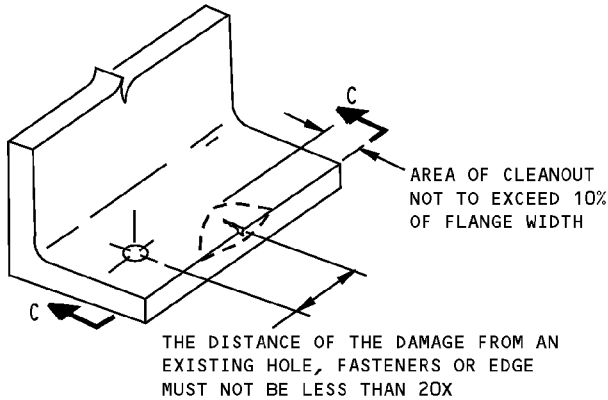
NO HOLE DAMAGE ALLOWED IN FLANGES FASTENED TO WEB.
HOLE DAMAGE NOT TO EXCEED 4 PLACES. FILL ALL HOLES
WITH 2117-T4 OR 2017-T3 ALUMINUM PROTRUDING HEAD
RIVETS INSTALLED WET WITH BMS 5-95. NO HOLE DAMAGE
ALLOWED CLOSER THAN 3.5 D TO EXISTING FASTENER.
NO HOLE DAMAGE ALLOWED IN SPLICES

H = WIDTH OF STIFFENER FLANGE

**ALLOWABLE DAMAGE LIMITS FOR HOLES IN ANGLES, TEES, STIFFENERS OR BEAMS
DETAIL XIV**



**DAMAGE CLEAN UP FOR EDGES OF LUG
DETAIL XV**



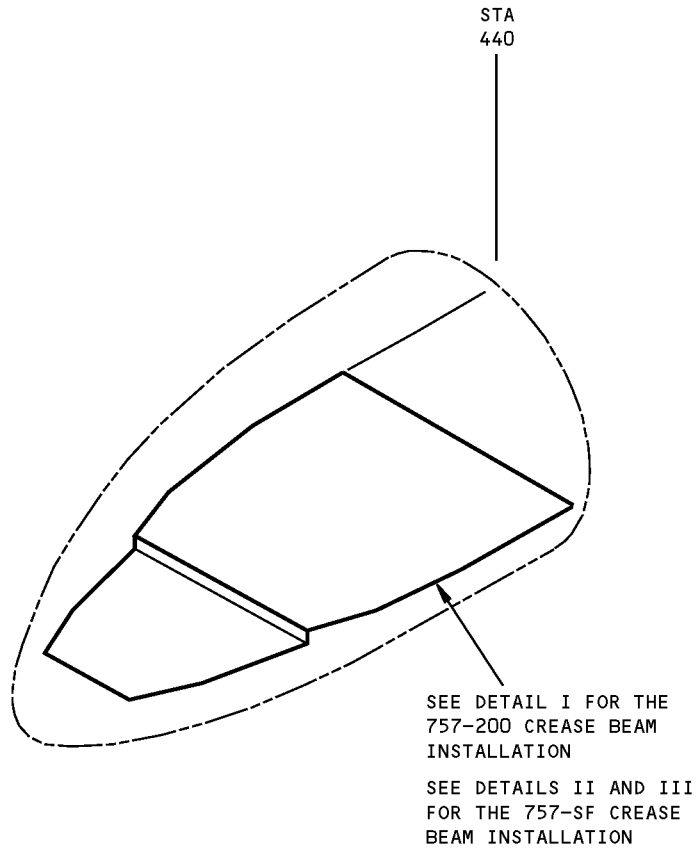
SECTION C-C

**REMOVAL OF NICK OR CRACK DAMAGE ON AN EDGE
DETAIL XVI**

**Section 41 Bulkhead Allowable Damage
Figure 101 (Sheet 10 of 10)**

**757-200
STRUCTURAL REPAIR MANUAL**

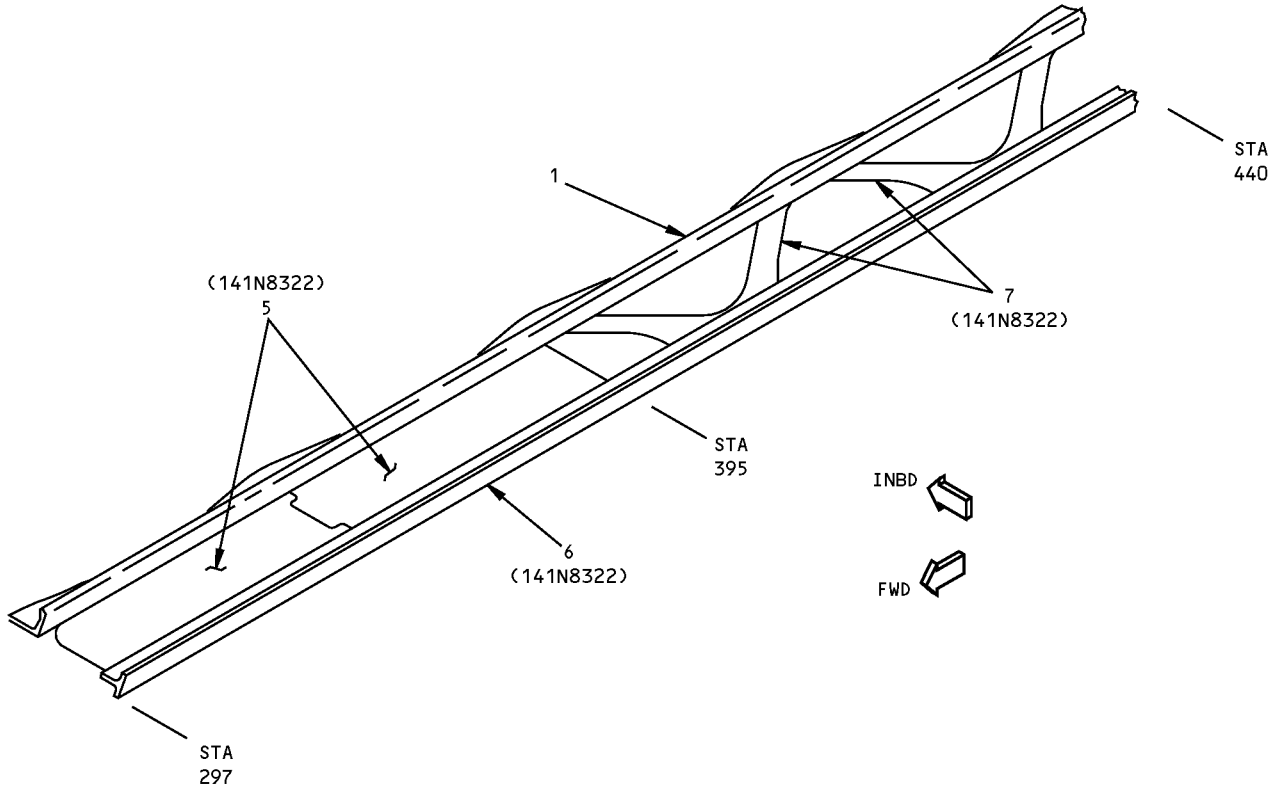
IDENTIFICATION 1 - SECTION 41 - CREASE BEAM



**Section 41 Crease Beam Identification
Figure 1 (Sheet 1 of 5)**

**757-200
STRUCTURAL REPAIR MANUAL**

REFERENCE DRAWING
141N8322



LEFT SIDE IS SHOWN, RIGHT SIDE IS OPPOSITE
DETAIL I

**Section 41 Crease Beam Identification
Figure 1 (Sheet 2 of 5)**

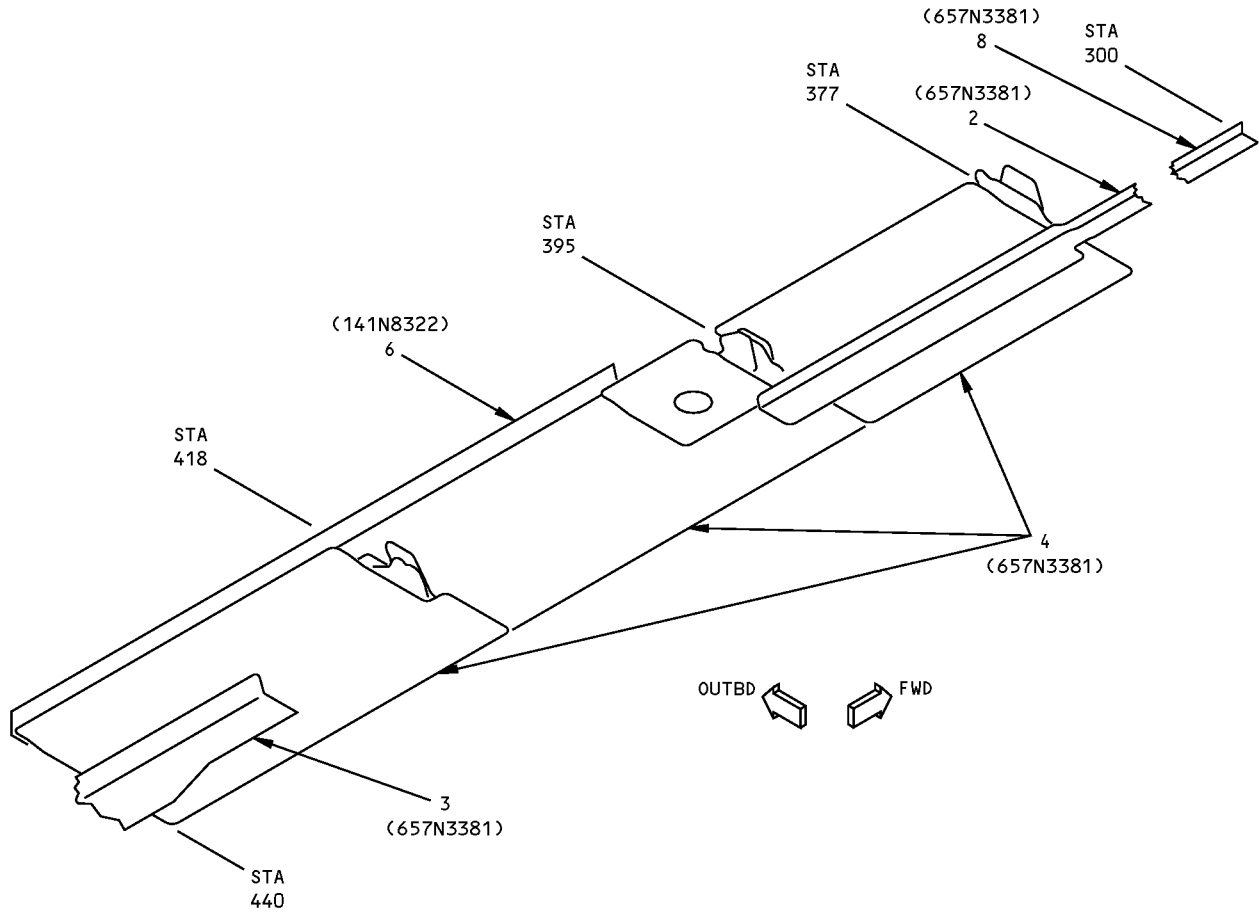
D634N201

53-10-13

IDENTIFICATION 1
Page 2
Jan 20/2005

**757-200
STRUCTURAL REPAIR MANUAL**

REFERENCE DRAWING
657N3381



LEFT SIDE
MODIFIED CREASE BEAM FOR 757-SF AIRPLANES ONLY
DETAIL II

NOTE: FOR CREASE BEAM CONTINUATION
FOR SECTION 43 SEE 53-30-13

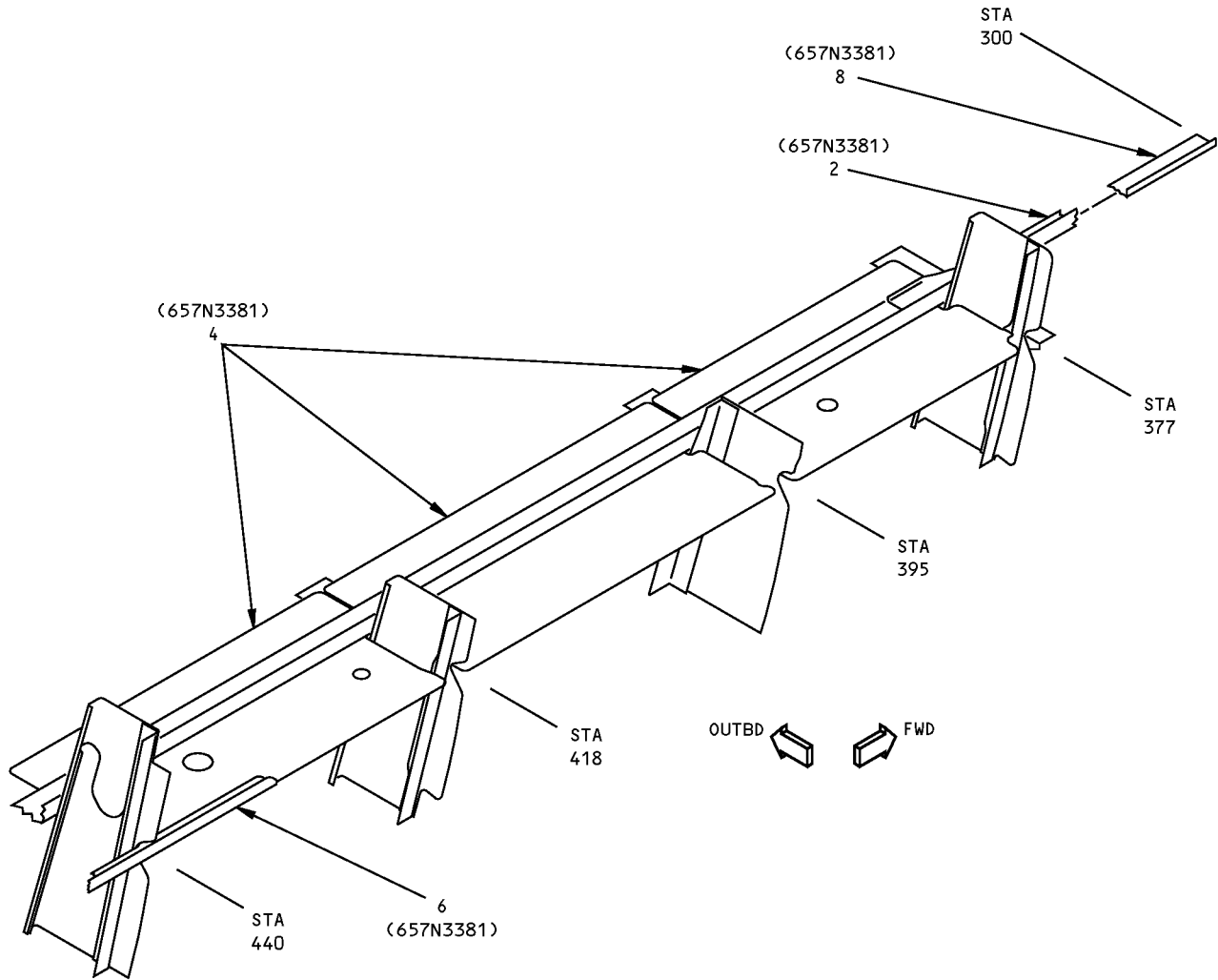
**Section 41 Crease Beam Identification
Figure 1 (Sheet 3 of 5)**

IDENTIFICATION 1
Page 3
Jan 20/2005

53-10-13

D634N201

**757-200
STRUCTURAL REPAIR MANUAL**



**RIGHT SIDE
MODIFIED CREASE BEAM FOR 757-SF AIRPLANES ONLY
DETAIL III**

NOTE: FOR CREASE BEAM CONINUATION
FOR SECTION 43 SEE 53-30-13

**Section 41 Crease Beam Identification
Figure 1 (Sheet 4 of 5)**



757-200
STRUCTURAL REPAIR MANUAL

ITEM	DESCRIPTION	GAGE	MATERIAL	EFFECTIVITY
1	INNER CHORD		BAC1515-553 2024-T3511	
2	INNER CHORD	0.071	7075-T62 CLAD	
3	INNER CHORD	0.100	7075-T62 CLAD	
4	WEB	0.100	7075-T62 CLAD	
5	WEB	0.040	7075-T6	
6	OUTER CHORD		BAC1506-2668 2024-T42	
7	TRUSS	0.040	7075-T6	
8	INNER CHORD		BAC1515-553 7075-T62	

LIST OF MATERIALS FOR DETAIL I, II AND III

Section 41 Crease Beam Identification
Figure 1 (Sheet 5 of 5)

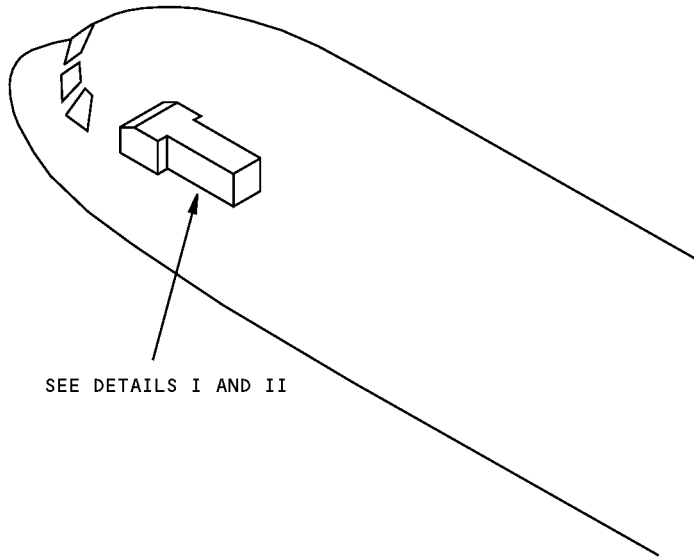
D634N201

53-10-13

IDENTIFICATION 1
Page 5
Jan 20/2005

757-200
STRUCTURAL REPAIR MANUAL

IDENTIFICATION 1 - NOSE WHEEL WELL STRUCTURE



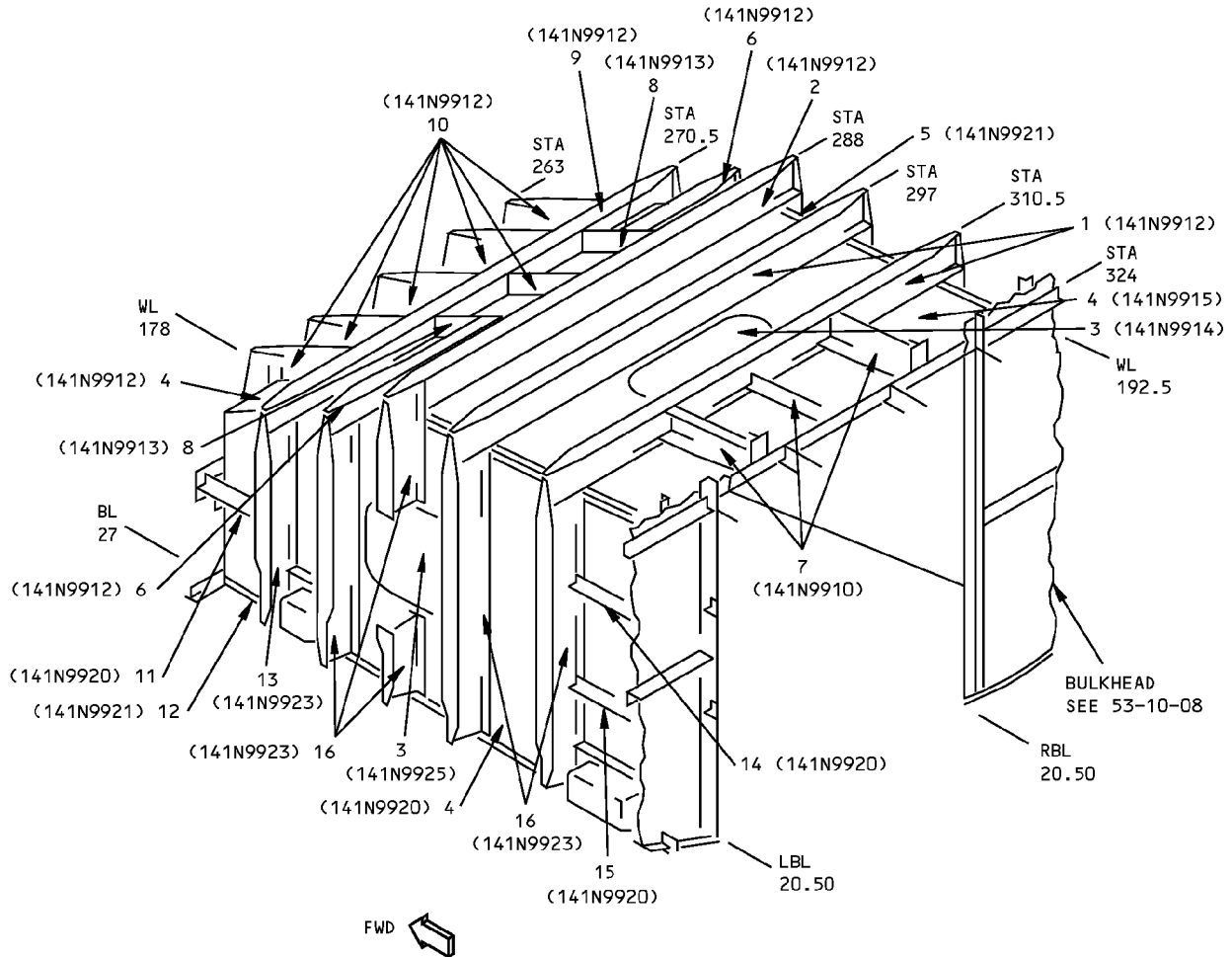
NOTES

- A** FOR CUM LINE NUMBERS:
1 THRU 31
- B** FOR CUM LINE NUMBERS:
32 AND ON

Nose Wheel Well Structure Identification
Figure 1 (Sheet 1 of 5)

**757-200
STRUCTURAL REPAIR MANUAL**

REF DWG
141N9910
141N9920



DETAIL I

LIST OF
MATERIAL

**Nose Wheel Well Structure Identification
Figure 1 (Sheet 2 of 5)**

IDENTIFICATION 1
Page 2
Jan 20/2005

53-10-14

D634N201



**757-200
STRUCTURAL REPAIR MANUAL**

ITEM	DESCRIPTION	GAGE	MATERIAL	EFFECTIVITY
1	BEAM		BAC1518-869 7075-T6511 OPTIONAL: BAC1518-840 7075-T6511 BAC1518-460 7075-T73511	
2	BEAM		BAC1518-920 OR BAC1518-797 2024-T3511	
3	DOOR	0.100	2024-T3	
4	WEB	0.100	2024-T3 CHEM-MILLED	
5	UPPER CHORD		AND10133-2003 7075-T6511	
6	BEAM		BAC1518-868 7075-T6511 OPTIONAL: BAC1518-796 7075-T6511	
7	STIFFENER		BAC1506-901 7075-T6511	
8	BEAM CHORD WEB	0.090	AND10136-3002 7075-T6511 CLAD 7075-T6	
9	BEAM		BAC1518-917 OR BAC1518-867 OR BAC1518-798 7075-T6511	
10	BEAM		BAC1518-795 7075-T6511	
11	STIFFENER		AND10133-1203 7075-T6511	
12	LOWER CHORD		BAC1506-3295 2024-T42	
13	BEAM		BAC1518-916 OR BAC1518-783 7075-T6511 OR AND10140-4006 7075-T6511	
14	STIFFENER		BAC1490-2793 CLAD 7075-T6	
15	STIFFENER		AND10136-2407 7075-T6511	
16	BEAM		BAC1518-916 OR BAC1518-788 7075-T6511	
17	BEAM		BAC1518-919 OR BAC1518-840 OR BAC1518-869 7075-T6511 OR BAC1518-460 7075-T73511	

LIST OF MATERIALS FOR DETAIL I

**Nose Wheel Well Structure Identification
Figure 1 (Sheet 3 of 5)**

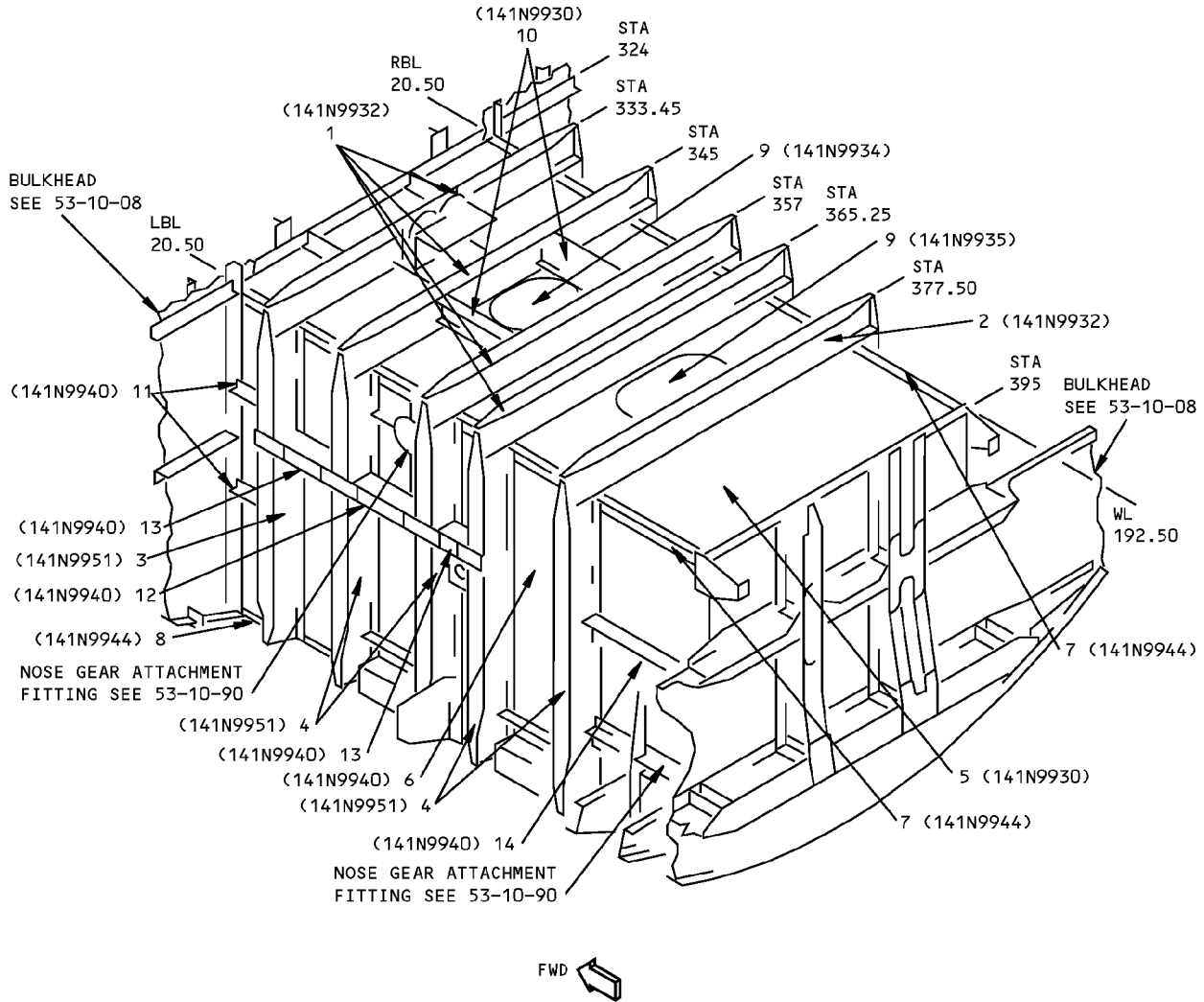
D634N201

53-10-14

IDENTIFICATION 1
Page 3
Jan 20/2005

**757-200
STRUCTURAL REPAIR MANUAL**

REF DWG
141N9930
141N9940



DETAIL II

LIST OF
MATERIAL

**Nose Wheel Well Structure Identification
Figure 1 (Sheet 4 of 5)**

IDENTIFICATION 1
Page 4
Jan 20/2005

53-10-14

D634N201



**757-200
STRUCTURAL REPAIR MANUAL**

ITEM	DESCRIPTION	GAGE	MATERIAL	EFFECTIVITY
1	BEAM		BAC1518-916 OR BAC1518-783 7075-T6511	
2	BEAM		BAC1518-822 OR BAC1518-923 7075-T6511 OR BAC1518-460 7075-T73511	
3	BEAM		BAC1518-789 7075-T6511	
4	BEAM		BAC1518-823 7075-T6511	
5	WEB	0.100	2024-T3 CHEM-MILLED	
6	WEB	0.080	2024-T3	A A B
	DOUBLER	0.080	2024-T3	
	WEB	0.160	2024-T3 MACHINED	
7	UPPER CHORD		AND10133-2004 7075-T6511	
8	LOWER CHORD		BAC1506-3294 2024-T42	
9	DOOR	0.112	2024-T3	
10	STIFFENER		BAC1505-901 7075-T6511	
11	STIFFENER		BAC1490-2685 CLAD 7075-T6	
12	STIFFENER	0.125	CLAD 7075-T6	
13	STIFFENER		BAC1518-679 7075-T73511 OPTIONAL: BAC1506-2400 7075-T6511	
14	STIFFENER		BAC1517-2173 7075-T73	

LIST OF MATERIALS FOR DETAIL II

**Nose Wheel Well Structure Identification
Figure 1 (Sheet 5 of 5)**

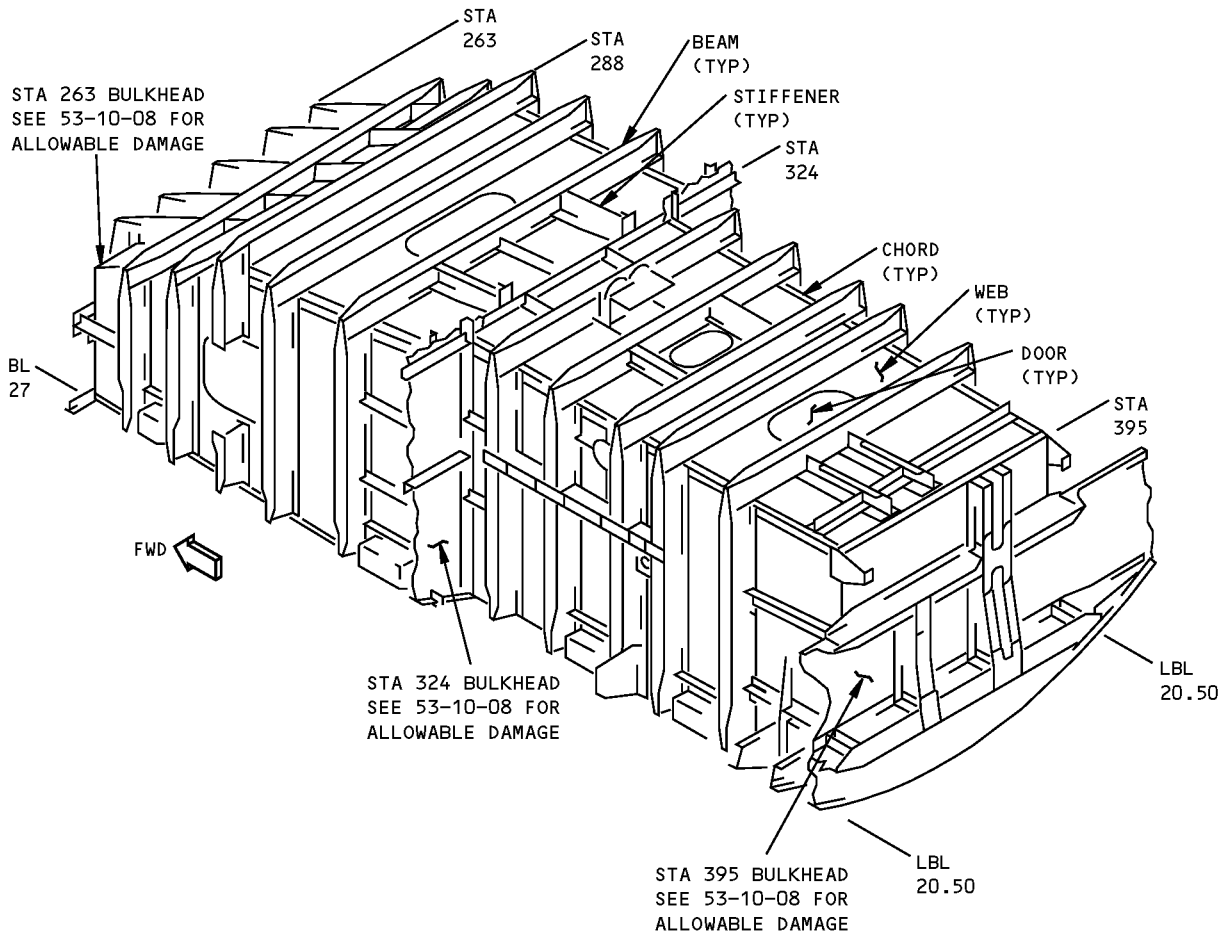
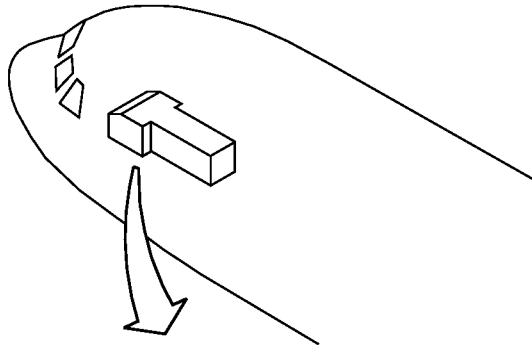
IDENTIFICATION 1
Page 5
Jan 20/2005

53-10-14

D634N201

**757-200
STRUCTURAL REPAIR MANUAL**

ALLOWABLE DAMAGE 1 - NOSE WHEEL WELL STRUCTURE



**Nose Wheel Well Structure Allowable Damage
Figure 101 (Sheet 1 of 5)**



757-200
STRUCTURAL REPAIR MANUAL

DESCRIPTION	CRACKS	NICKS, GOUGES AND CORROSION	DENTS	HOLES AND PUNCTURES
BEAMS	A	C	NOT ALLOWED	F
CHORDS	A	C	NOT ALLOWED	NOT ALLOWED
WEBS AND DOORS	B	E	SEE DETAIL III	D
STIFFENERS	A	C	NOT ALLOWED	SEE DETAIL V

NOTES

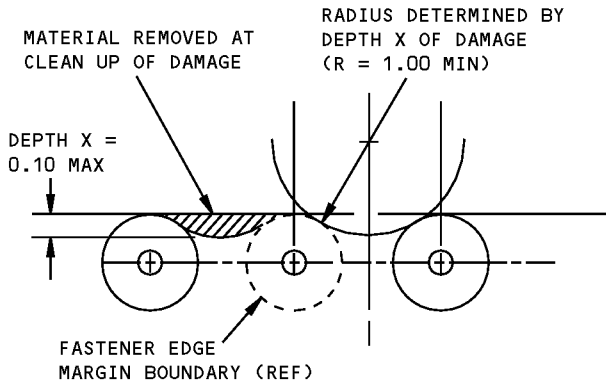
- SEE 53-10-90 FOR NOSE LANDING GEAR ATTACHMENT FITTING ALLOWABLE DAMAGE
- REFINISH REWORKED AREAS PER 51-20 OF THE MAINTENANCE MANUAL

- A CRACKS NOT ALLOWED EXCEPT FOR EDGE CRACKS WHICH MUST BE REMOVED PER DETAILS I AND VI
- B CRACKS NOT ALLOWED EXCEPT FOR EDGE CRACKS WHICH MUST BE REMOVED PER DETAILS I AND VII
- C REMOVE DAMAGE PER DETAILS I, II, IV, AND VI
- D CLEAN OUT DAMAGE UP TO 0.25 MAX DIA AND NOT CLOSER THAN 1.0 INCH TO FASTENER HOLE OR OTHER DAMAGE. MAINTAIN MINIMUM EDGE MARGIN OF 1.5 D. FILL HOLE WITH A 2117-T3 OR T4 ALUMINUM RIVET INSTALLED WET WITH BMS 5-95 SEALANT. ALL OTHER HOLES TO BE REPAIRED

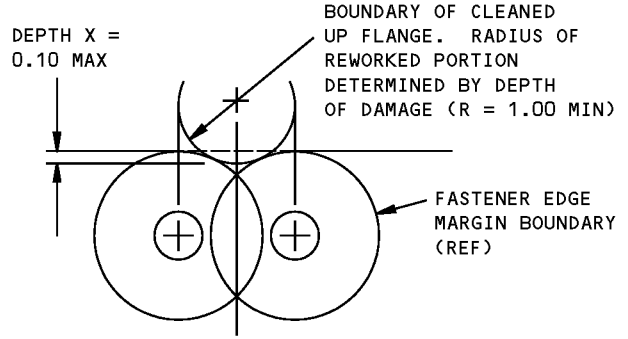
- E REMOVE DAMAGE PER DETAILS I, II, IV, AND VII
- F HOLES ALLOWED IN WEBS AND FREE FLANGES OF BEAM ONLY. CLEAN OUT DAMAGE UP TO 0.25 MAX DIA AND NOT CLOSER THAN 1.0 INCH TO FASTENER HOLE OR OTHER DAMAGE. MAINTAIN MINIMUM EDGE MARGIN OF 1.5 D. FILL HOLE WITH A 2117-T3 OR T4 ALUMINUM RIVET INSTALLED WET WITH BMS 5-95 SEALANT. ALL OTHER HOLES TO BE REPAIRED

Nose Wheel Well Structure Allowable Damage
Figure 101 (Sheet 2 of 5)

STRUCTURAL REPAIR MANUAL

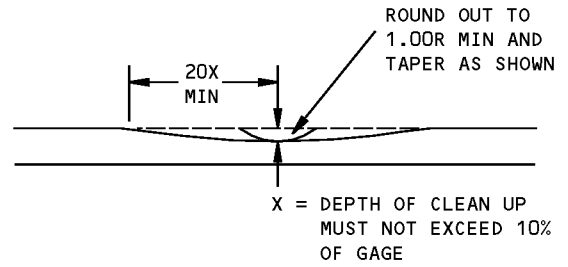
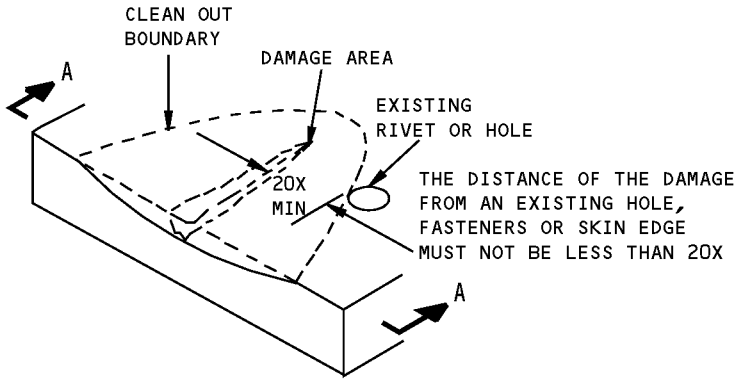


DAMAGE CLEAN UP OF EDGES WHERE FASTENER EDGE MARGINS DO NOT OVERLAP



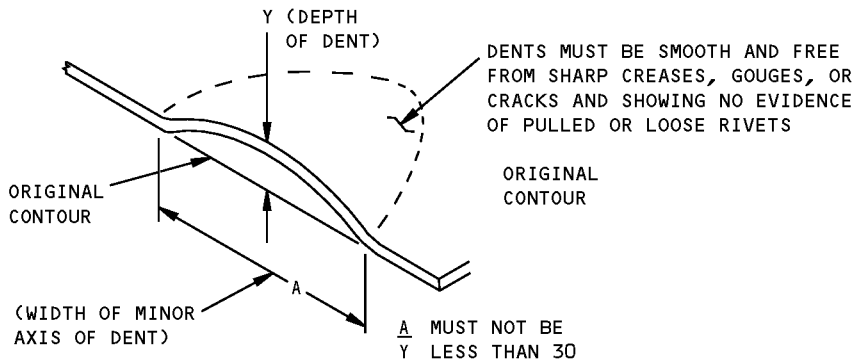
DAMAGE CLEAN UP OF EDGES WHERE FASTENER EDGE MARGINS OVERLAP

DETAIL I



SECTION A-A

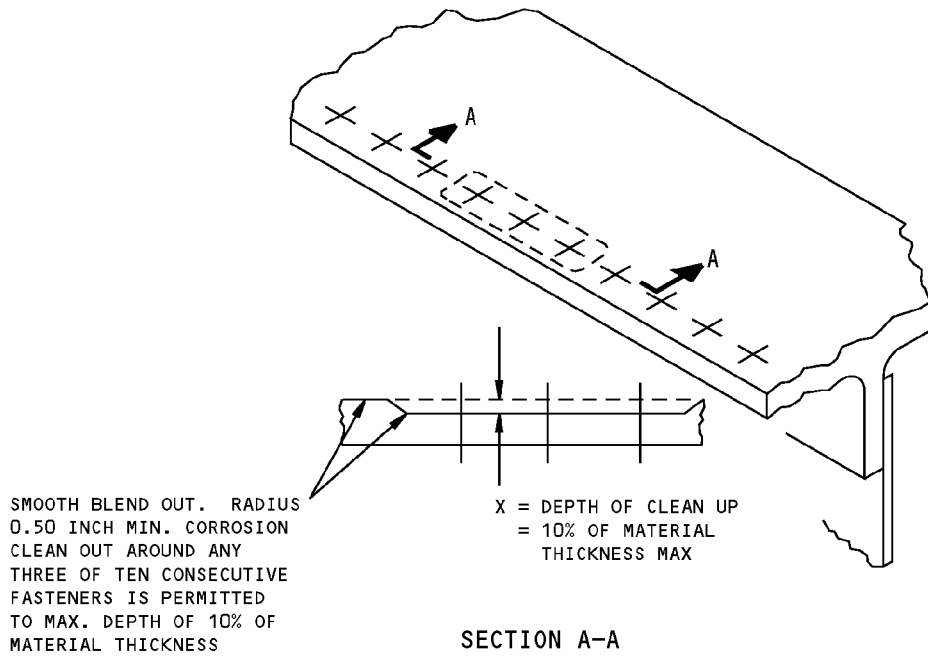
DETAIL II



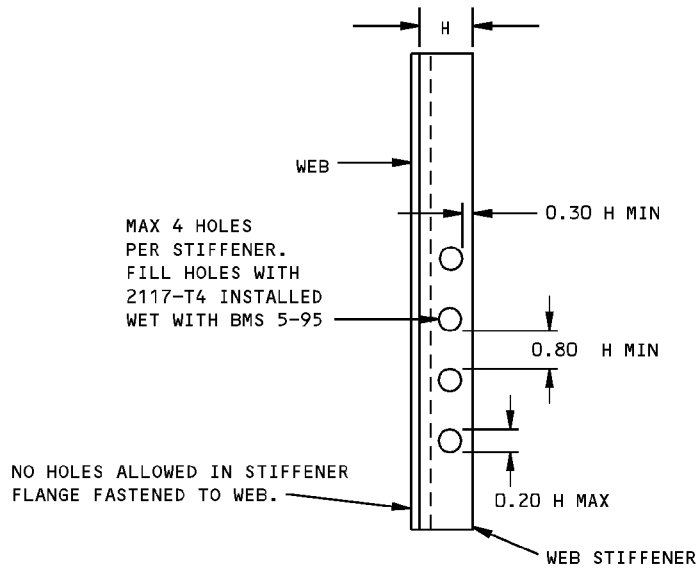
DETAIL III

Nose Wheel Well Structure Allowable Damage
Figure 101 (Sheet 3 of 5)

**757-200
STRUCTURAL REPAIR MANUAL**



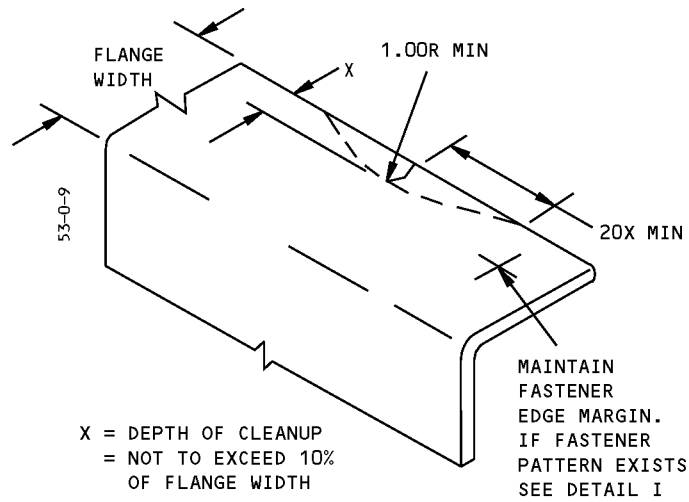
**SECTION A-A
CORROSION CLEANUP
DETAIL IV**



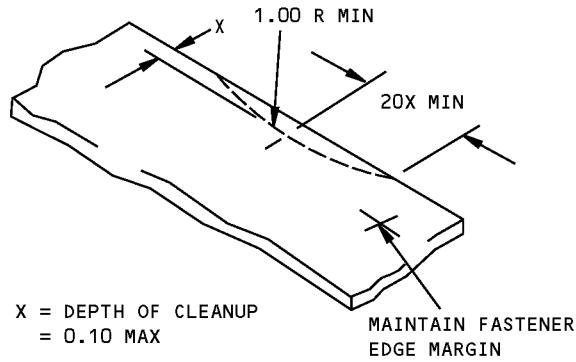
**TYPICAL FOR ALL STIFFENERS
DETAIL V**

**Nose Wheel Well Structure Allowable Damage
Figure 101 (Sheet 4 of 5)**

**757-200
STRUCTURAL REPAIR MANUAL**



**REMOVAL OF NICK OR CRACK
DAMAGE ON AN EDGE
DETAIL VI**



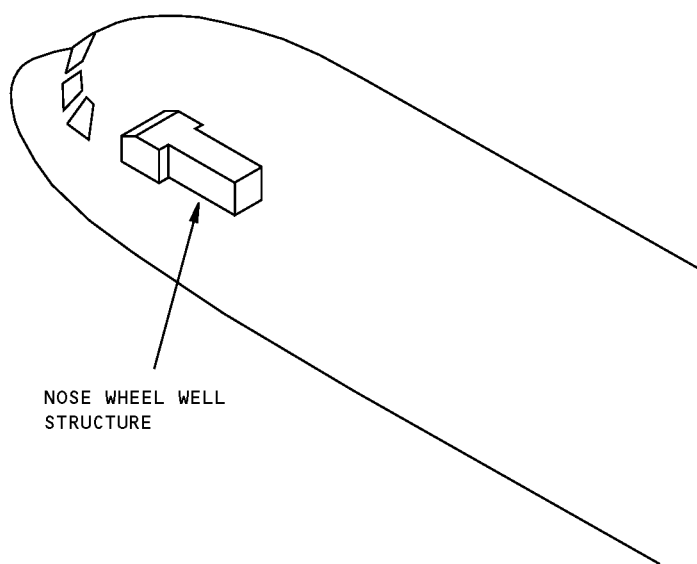
**REMOVAL OF NICK OR CRACK
DAMAGE ON AN EDGE
DETAIL VII**

**Nose Wheel Well Structure Allowable Damage
Figure 101 (Sheet 5 of 5)**

757-200
STRUCTURAL REPAIR MANUAL

REPAIR GENERAL - NOSE WHEEL WELL STRUCTURE

APPLICABILITY
THIS REPAIR DOES NOT APPLY TO PRESSURE WEBS, BULKHEAD WEBS AT STA 263, STA 324, AND STA 395, AND THE EXTRUDED WEB STIFFENERS



NOTES

- SEE 51-70-11 FOR FORMED SECTION REPAIR
- SEE 51-70-12 FOR EXTRUDED SECTION REPAIR
- SEE 51-70-13 FOR WEB REPAIRS TO CONSTANT THICKNESS WEB SECTION
- NO REPAIRS ALLOWED TO FITTINGS

**Nose Wheel Well Structure Repair
Figure 201**

D634N201

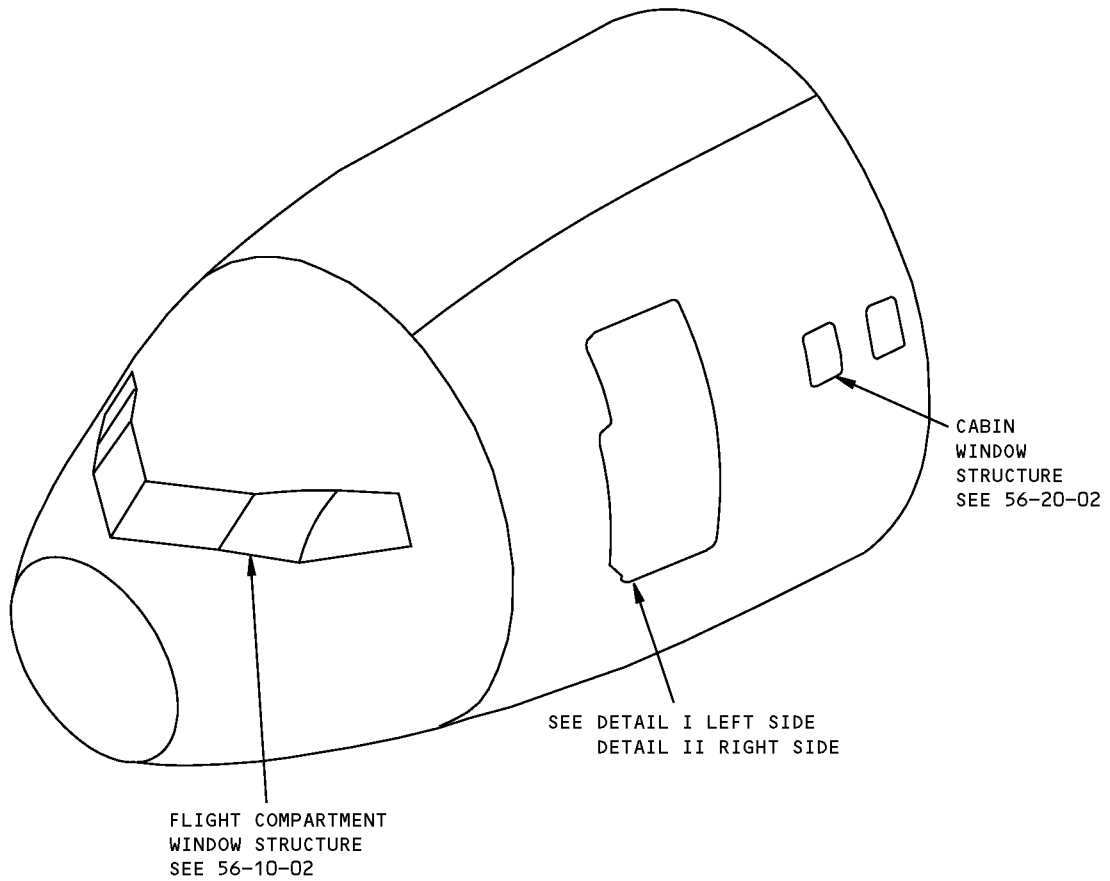
53-10-14

REPAIR GENERAL
Page 201
Jan 20/2005



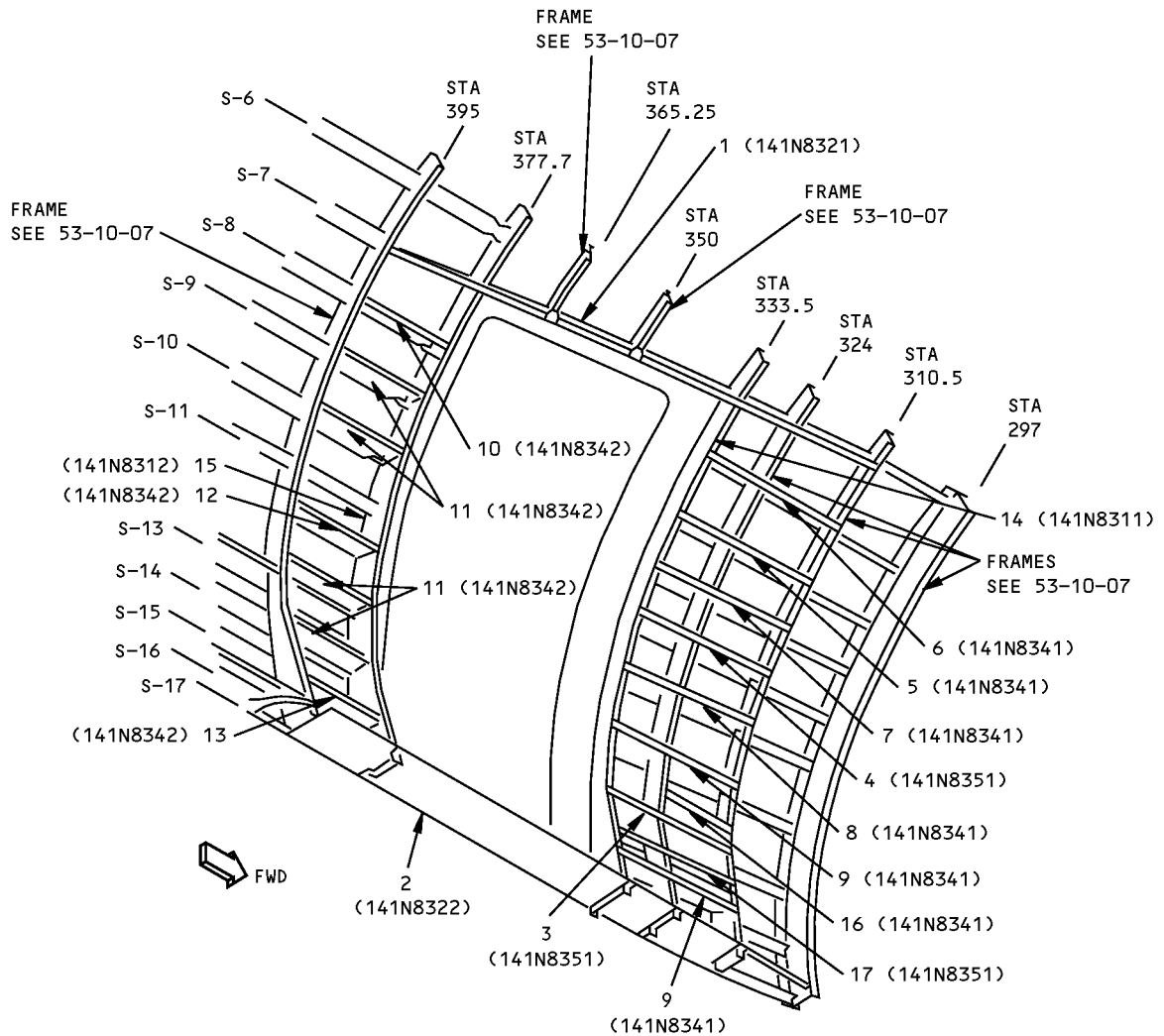
757-200
STRUCTURAL REPAIR MANUAL

IDENTIFICATION 1 - SECTION 41 - DOOR SURROUND STRUCTURE



Section 41 Door Surround Structure Identification
Figure 1 (Sheet 1 of 5)

**757-200
STRUCTURAL REPAIR MANUAL**



LEFT SIDE
DETAIL I



**Section 41 Door Surround Structure Identification
Figure 1 (Sheet 2 of 5)**

IDENTIFICATION 1
Page 2
Jan 20/2005

53-10-15

D634N201



**757-200
STRUCTURAL REPAIR MANUAL**

ITEM	DESCRIPTION	GAGE	MATERIAL	EFFECTIVITY
1	UPPER SILL OUTBD CHORD WEB INBD CHORD	0.040 0.063	BAC1505-100236 2024-T42 CLAD 7075-T6 CLAD 2024-T42	
2	LOWER SILL OUTBD CHORD WEB INBD CHORD	0.040	BAC1506-2668 2024-T42 CLAD 7075-T6 BAC1515-553 2024-T3511	
3	LOWER HINGE INTER- COSTAL OUTER CHORD FWD WEB AFT WEB	0.063 0.050	BAC1514-1539 7075-T6 CLAD 7075-T6 CLAD 7075-T6	
4	UPPER HINGE INTER- COSTAL OUTER CHORD WEB	0.050	BAC1506-3610 7075-T6 CLAD 7075-T6	
5	INTERCOSTAL CHORD FWD WEB AFT WEB	0.090 0.050	AND10134-1205 2024-T42 CLAD 2024-T42 CLAD 2024-T42	
6	INTERCOSTAL CHORD FWD WEB AFT WEB	0.090 0.063	AND10134-1205 2024-T42 CLAD 2024-T42 CLAD 2024-T42	
7	INTERCOSTAL CHORD FWD WEB AFT WEB	0.080 0.050	AND10134-1205 2024-T42 CLAD 2024-T42 CLAD 2024-T42	
8	INTERCOSTAL CHORD FWD WEB AFT WEB	0.063 0.050	BAC1514-1230 2024-T42 CLAD 2024-T42 CLAD 2024-T42	
9	INTERCOSTAL CHORD FWD WEB AFT WEB	0.063 0.050	AND10134-1205 2024-T42 CLAD 2024-T42 CLAD 2024-T42	
10	INTERCOSTAL	0.090	CLAD 2024-T42	
11	INTERCOSTAL	0.063	CLAD 2024-T42	
12	INTERCOSTAL	0.050	CLAD 2024-T42	
13	INTERCOSTAL	0.071	CLAD 2024-T42	
14	FRAME OUTER CHORD WEB	0.090	BAC1514-2632 2024-T42 CLAD 2024-T42	
15	FRAME OUTER CHORD WEB	0.080	BAC1505-101237 2024-T42 CLAD 2024-T42	
16	INTERCOSTAL	0.063	CLAD 7075-T6	
17	INTERCOSTAL CHORD FWD WEB AFT WEB	0.071 0.050	AND10134-1205 2024-T42 CLAD 2024-T42 CLAD 2024-T42	

LIST OF MATERIALS FOR DETAIL I

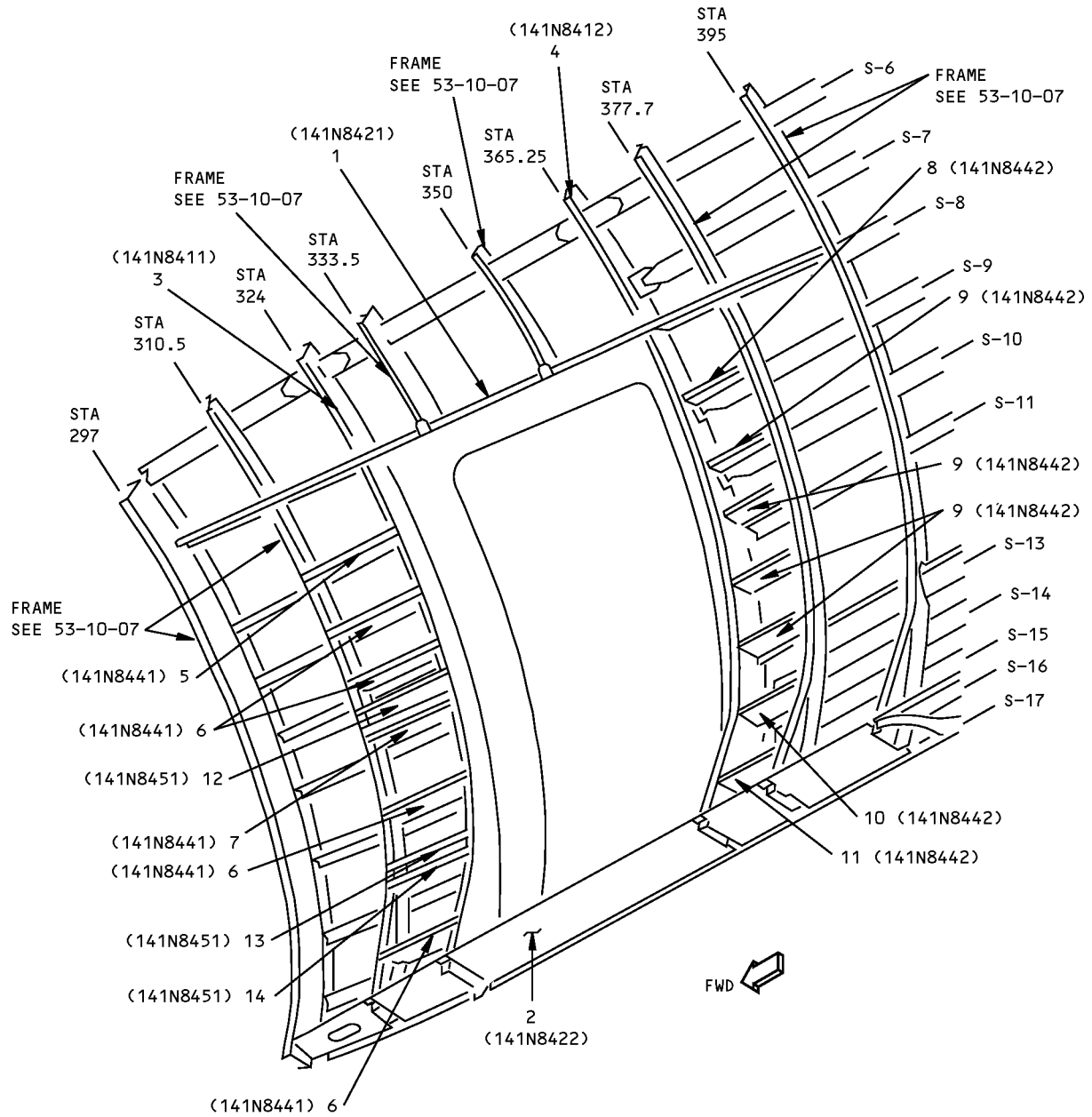
**Section 41 Door Surround Structure Identification
Figure 1 (Sheet 3 of 5)**

IDENTIFICATION 1
Page 3
Jan 20/2005

53-10-15

D634N201

**757-200
STRUCTURAL REPAIR MANUAL**



RIGHT SIDE
DETAIL II



**Section 41 Door Surround Structure Identification
Figure 1 (Sheet 4 of 5)**



**757-200
STRUCTURAL REPAIR MANUAL**

ITEM	DESCRIPTION	GAGE	MATERIAL	EFFECTIVITY
1	UPPER SILL OUTBD CHORD FWD OUTBD CHORD AFT WEB-FWD WEB-CTR WEB-AFT INBD CHORD	0.063 0.040 0.063 0.063	BAC1506-3161 2024-T42 BAC1505-100236 2024-T42 CLAD 7075-T6 CLAD 7075-T6 CLAD 7075-T6 CLAD 2024-T42	
2	LOWER SILL OUTBD CHORD WEB INBD CHORD	0.040	BAC1506-2668 2024-T42 CLAD 7075-T6 BAC1515-553 2024-T3511	
3	FRAME OUTER CHORD WEB	0.090	BAC1514-2632 2024-T42 CLAD 2024-T42	
4	FRAME OUTER CHORD WEB	0.080	BAC1505-101237 2024-T42 CLAD 2024-T42	
5	INTERCOSTAL CHORD WEB	0.080	AND10134-1205 2024-T42 CLAD 2024-T42	
6	INTERCOSTAL CHORD WEB	0.063	AND10134-1205 2024-T42 CLAD 2024-T42	
7	INTERCOSTAL CHORD WEB	0.063	BAC1514-1230 2024-T42 CLAD 2024-T42	
8	INTERCOSTAL	0.090	CLAD 2024-T42	
9	INTERCOSTAL	0.063	CLAD 2024-T42	
10	INTERCOSTAL	0.050	CLAD 2024-T42	
11	INTERCOSTAL	0.071	CLAD 2024-T42	
12	UPPER HINGE INTER- COSTAL CHORD WEB	0.050	BAC1506-3160 7075-T6 CLAD 7075-T6	
13	LOWER HINGE INTER- COSTAL CHORD WEB	0.063	BAC1514-1539 7075-T6511 CLAD 7075-T6	
14	INTERCOSTAL CHORD WEB	0.063	AND10134-1205 2024-T3511 CLAD 2024-T42	

LIST OF MATERIALS FOR DETAIL II

**Section 41 Door Surround Structure Identification
Figure 1 (Sheet 5 of 5)**

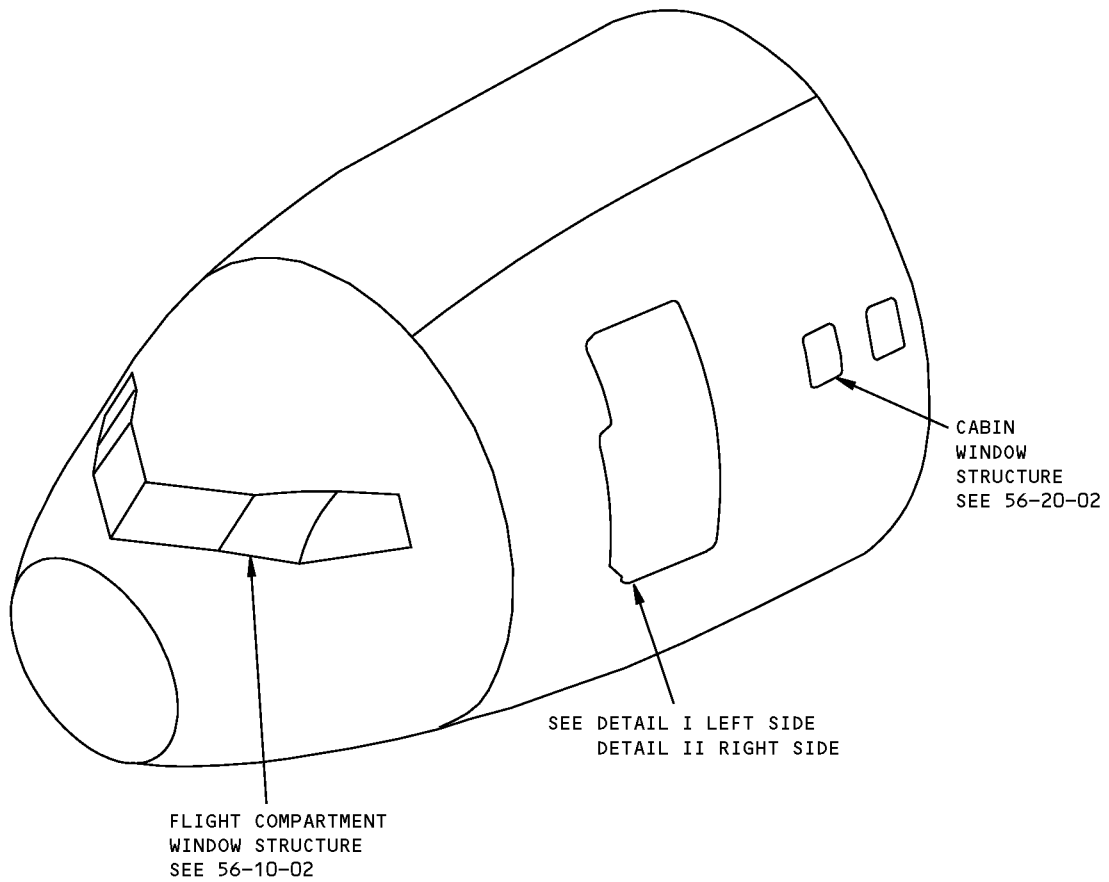
D634N201

53-10-15

IDENTIFICATION 1
Page 5
Jan 20/2005

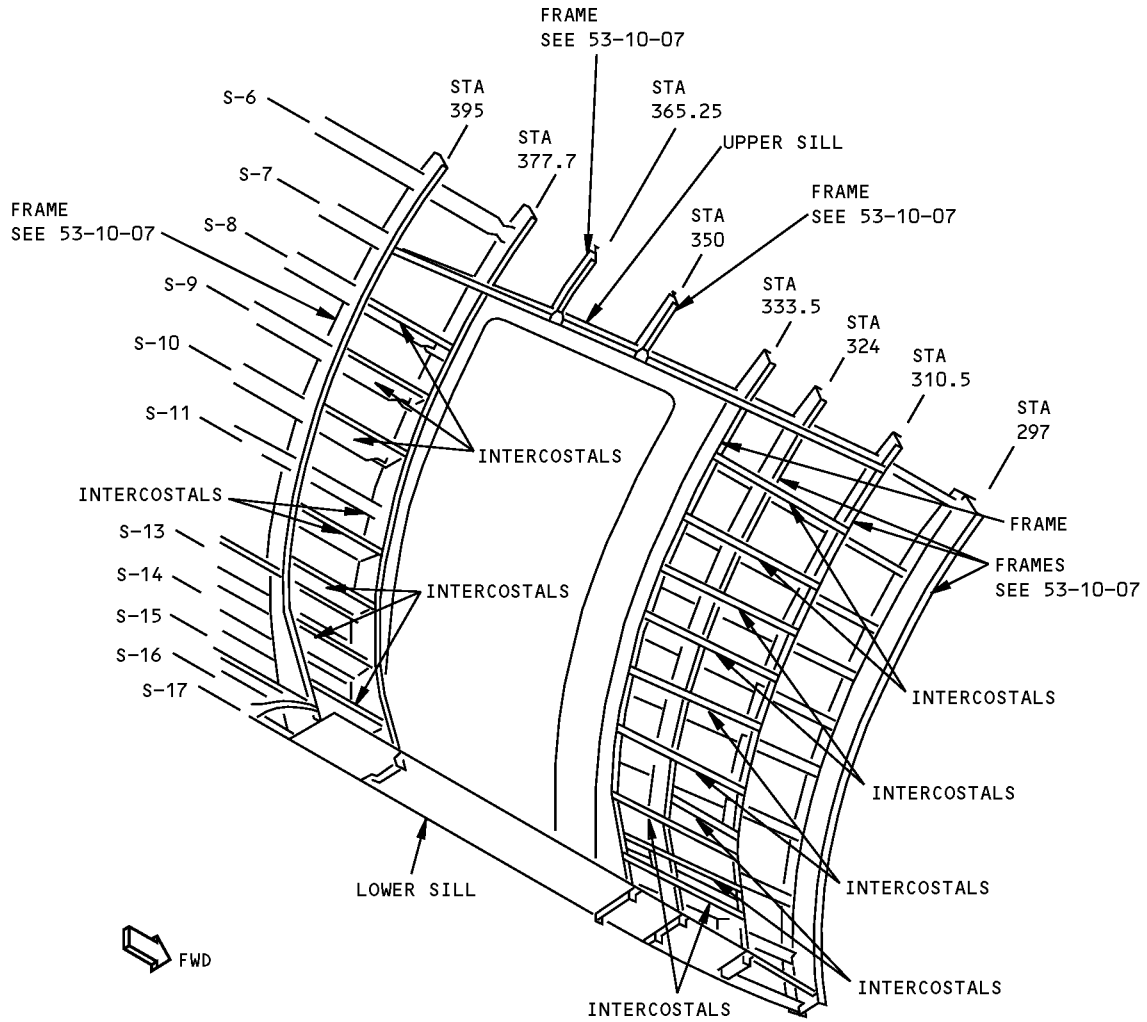
757-200
STRUCTURAL REPAIR MANUAL

ALLOWABLE DAMAGE 1 - SECTION 41 - DOOR SURROUND STRUCTURE



Section 41 Door Surround Structure Allowable Damage
Figure 101 (Sheet 1 of 5)

**757-200
STRUCTURAL REPAIR MANUAL**



MATERIAL: ALUMINUM

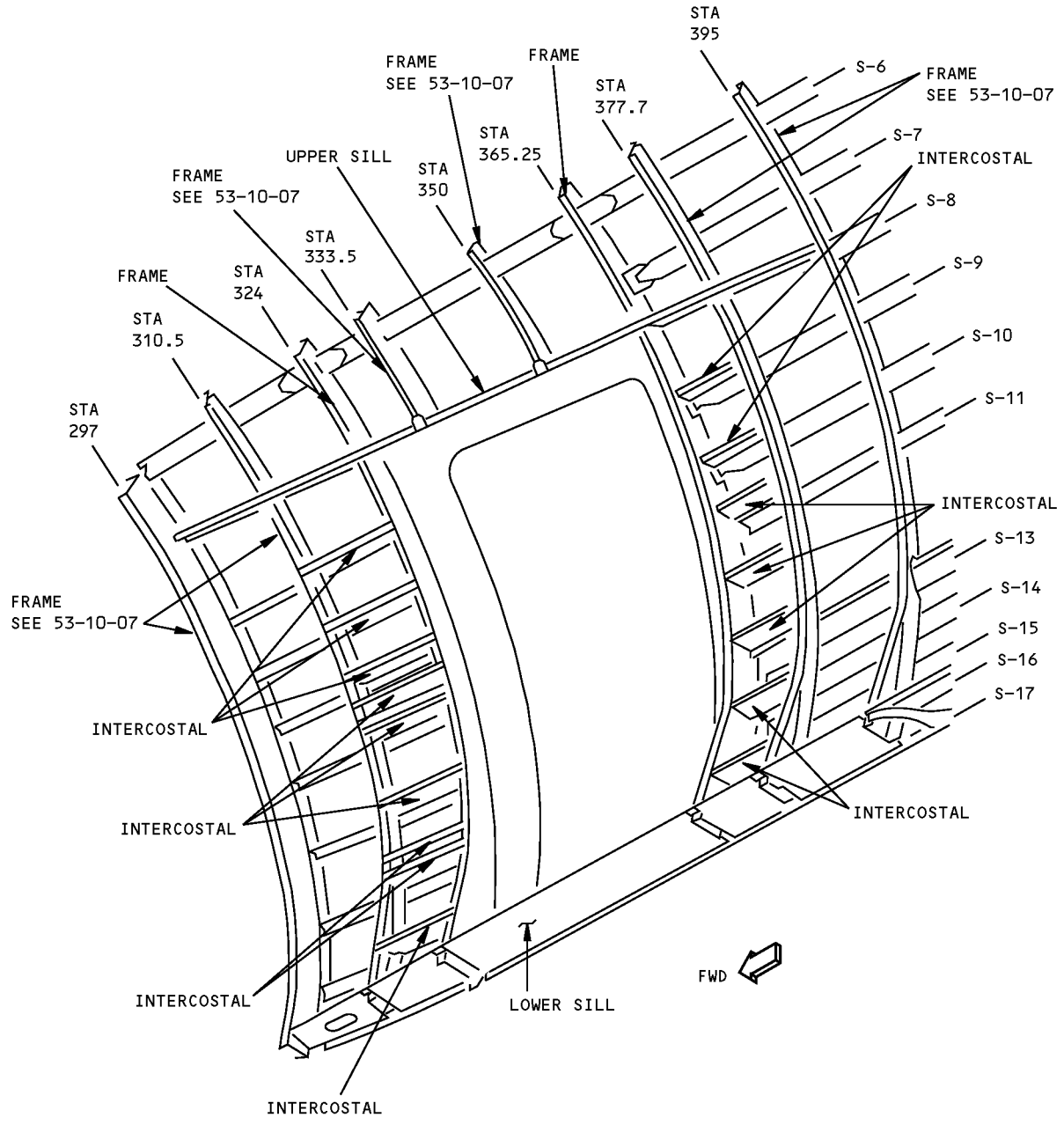
LEFT SIDE
DETAIL I

**Section 41 Door Surround Structure Allowable Damage
Figure 101 (Sheet 2 of 5)**

D634N201

ALLOWABLE DAMAGE 1
53-10-15
Page 102
Jan 20/2005

**757-200
STRUCTURAL REPAIR MANUAL**



MATERIAL: ALUMINUM

RIGHT SIDE
DETAIL II

**Section 41 Door Surround Structure Allowable Damage
Figure 101 (Sheet 3 of 5)**

D634N201

ALLOWABLE DAMAGE 1
53-10-15
Page 103
Jan 20/2005

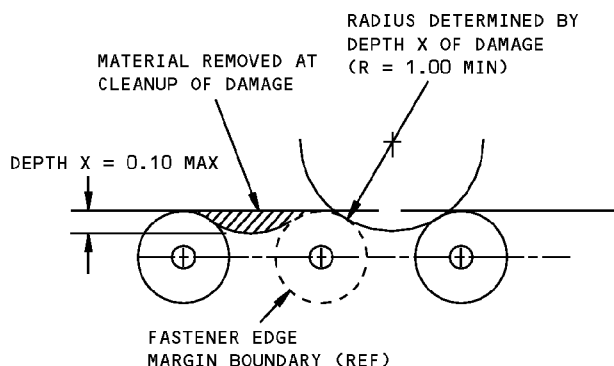
**757-200
STRUCTURAL REPAIR MANUAL**

DESCRIPTION	CRACKS	NICKS, GOUGES AND CORROSION	DENTS	HOLES AND PUNCTURES
SILLS CHORDS WEBS	A C	B B	NOT PERMITTED SEE DETAIL V	NOT PERMITTED D
FRAMES CHORDS WEBS	A C	B B	NOT PERMITTED SEE DETAIL V	NOT PERMITTED D
INTERCOSTALS CHORDS WEBS	A C	B B	NOT PERMITTED SEE DETAIL V	NOT PERMITTED D

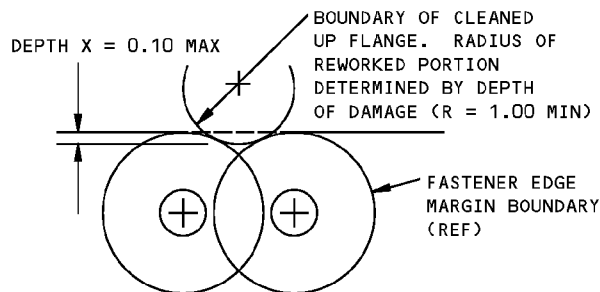
NOTES

- THIS ALLOWABLE DAMAGE IS A CATEGORY A REPAIR FOR 757-SF AIRPLANES. THE INSPECTIONS GIVEN IN THE MAINTENANCE PLANNING DATA (MPD) AND ASSOCIATED SUPPLEMENT ARE SUFFICIENT TO MAINTAIN THE DAMAGE TOLERANCE OF THE INITIAL STRUCTURE WITH THIS ALLOWABLE DAMAGE. REFER TO SRM 51-00-06 FOR REPAIR CATEGORIES AND DEFINITIONS.
- REFINISH REWORKED AREAS AS GIVEN IN AMM 51-20.
- ALL DIMENSIONS ARE IN INCHES.

- A** CRACKS NOT PERMITTED EXCEPT FOR EDGE CRACKS WHICH MUST BE REMOVED AS SHOWN IN DETAILS III AND VIII
- B** REMOVE DAMAGE AS SHOWN IN DETAILS III, IV, AND VI
- C** CRACKS NOT PERMITTED EXCEPT FOR EDGE CRACKS WHICH MUST BE REMOVED AS SHOWN IN DETAILS III AND VII
- D** CLEAN OUT DAMAGE UP TO 0.25 MAX DIA AND NOT CLOSER THAN 1.0 INCH TO FASTENER HOLE OR OTHER DAMAGE. FILL HOLE WITH A 2117-T3 OR T4 ALUMINUM RIVET INSTALLED WET WITH BMS 5-95 SEALANT. ALL OTHER HOLES TO BE REPAIRED



DAMAGE CLEANUP OF EDGES WHERE
FASTENER EDGE MARGINS DO NOT OVERLAP

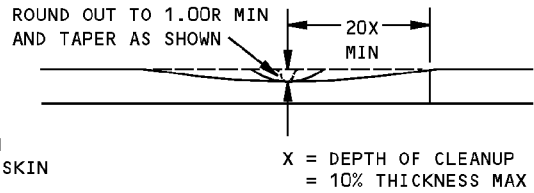
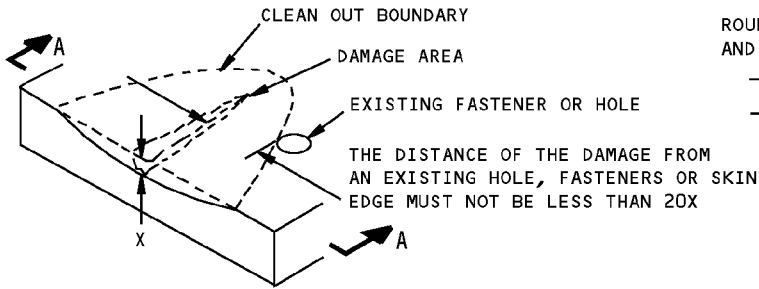


DAMAGE CLEANUP OF EDGES WHERE
FASTENER EDGE MARGINS OVERLAP

DETAIL III

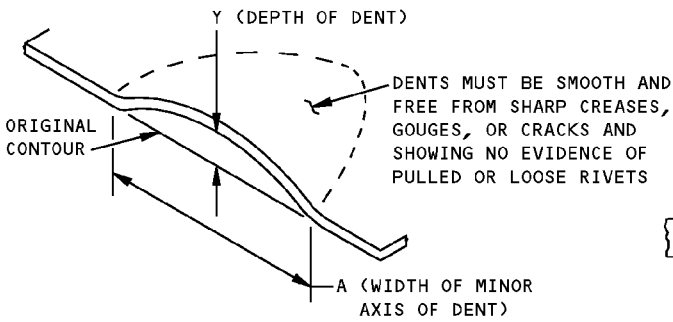
**Section 41 Door Surround Structure Allowable Damage
Figure 101 (Sheet 4 of 5)**

STRUCTURAL REPAIR MANUAL



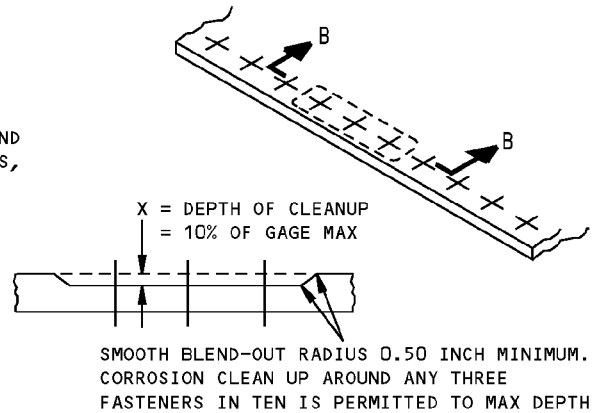
SECTION A-A

REMOVAL OF NICK, GOUGE AND SCRATCH DAMAGE ON A SURFACE
DETAIL IV



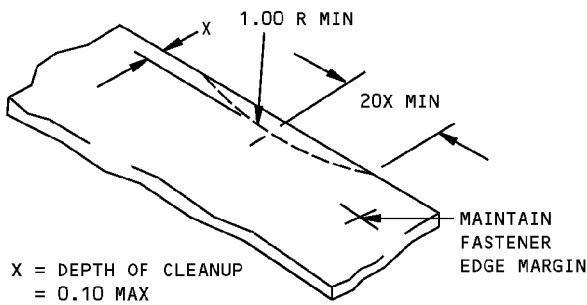
$\frac{A}{Y}$ MUST NOT BE LESS THAN 30

ALLOWABLE DAMAGE FOR DENT
DETAIL V

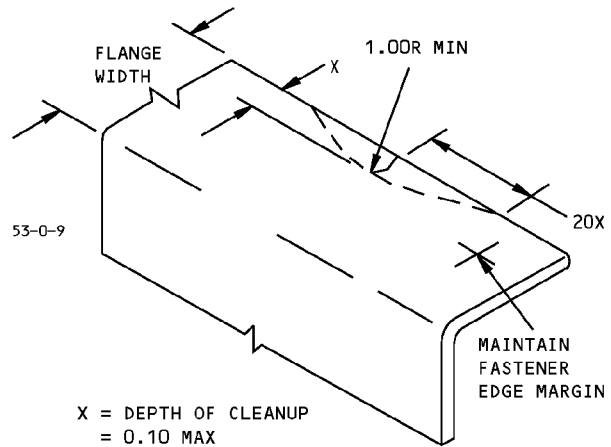


SECTION B-B

CORROSION CLEANUP
DETAIL VI



REMOVAL OF NICK OR CRACK
DAMAGE ON AN EDGE
DETAIL VII

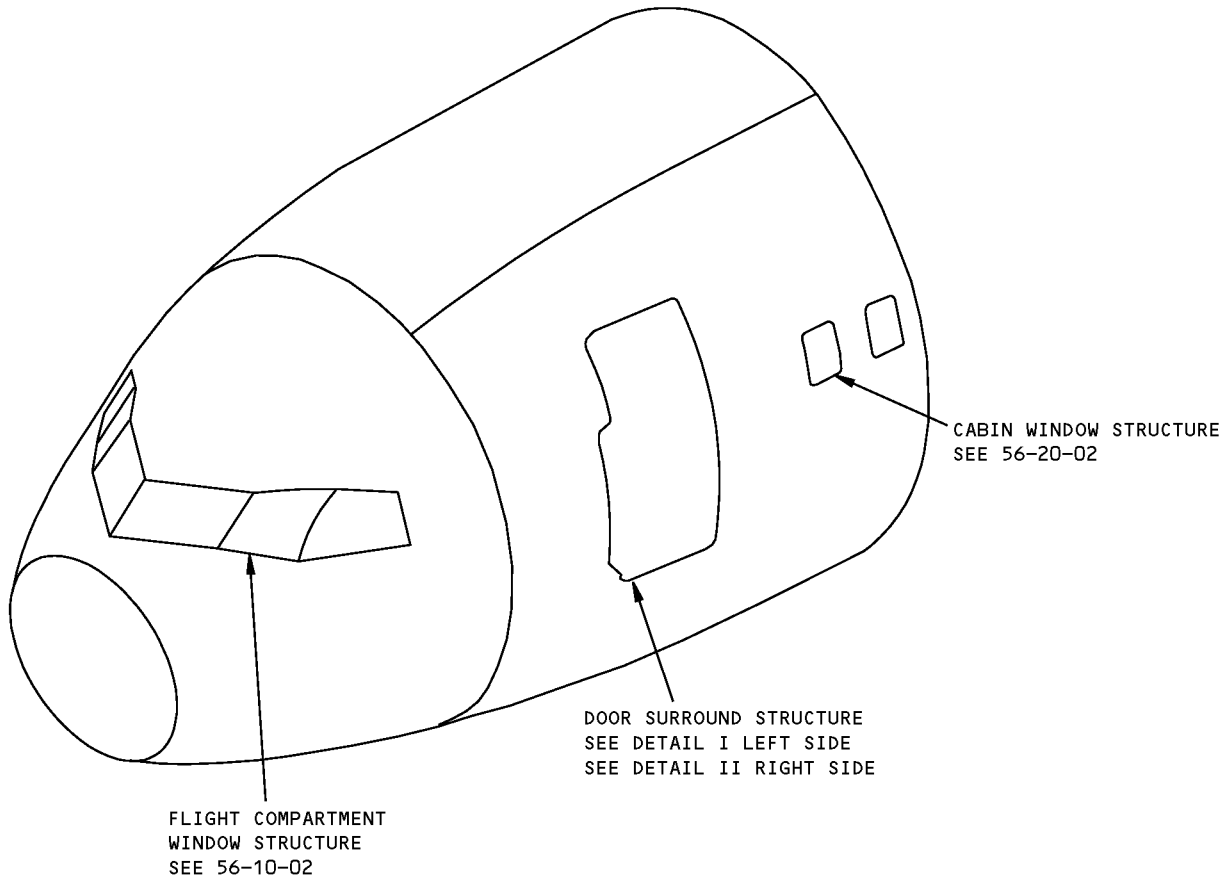


REMOVAL OF NICK OR CRACK
DAMAGE ON AN EDGE
DETAIL VIII

Section 41 Door Surround Structure Allowable Damage
Figure 101 (Sheet 5 of 5)

757-200
STRUCTURAL REPAIR MANUAL

REPAIR GENERAL - SECTION 41 - DOOR SURROUND STRUCTURE



NOTES

- THIS REPAIR DATA IS APPLICABLE TO PASSENGER AIRPLANES ONLY.
- DAMAGED COMPONENTS IN DOOR SURROUND STRUCTURE MAY BE REPLACED OR REPAIRED. IF REPAIRS ARE TO BE MADE, SEE 51-70 FOR TYPICAL WEB, AND EXTRUDED SECTION REPAIRS.

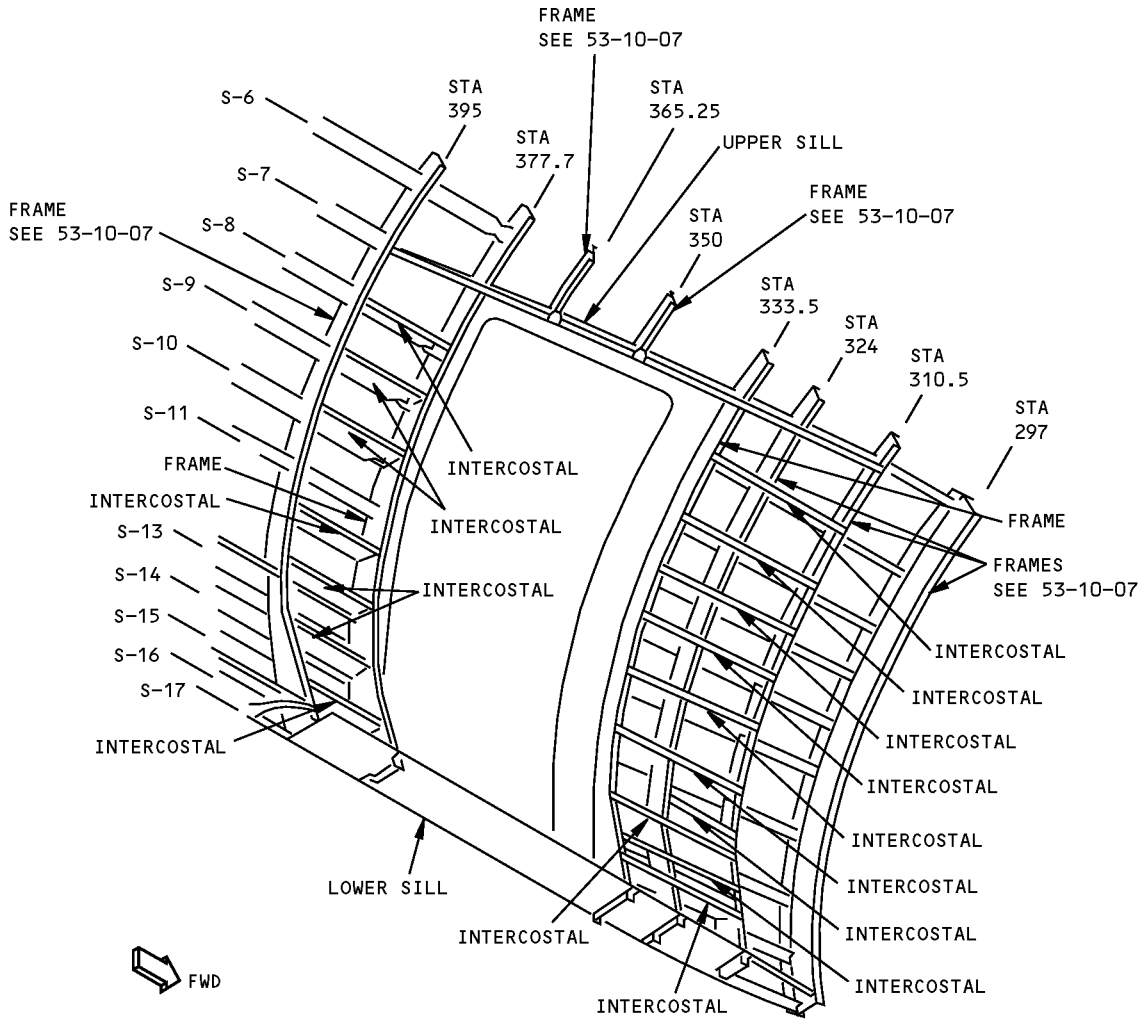
**Section 41 Door Surround Structure Repair
Figure 201 (Sheet 1 of 3)**

D634N201

53-10-15

REPAIR GENERAL
Page 201
Jan 20/2005

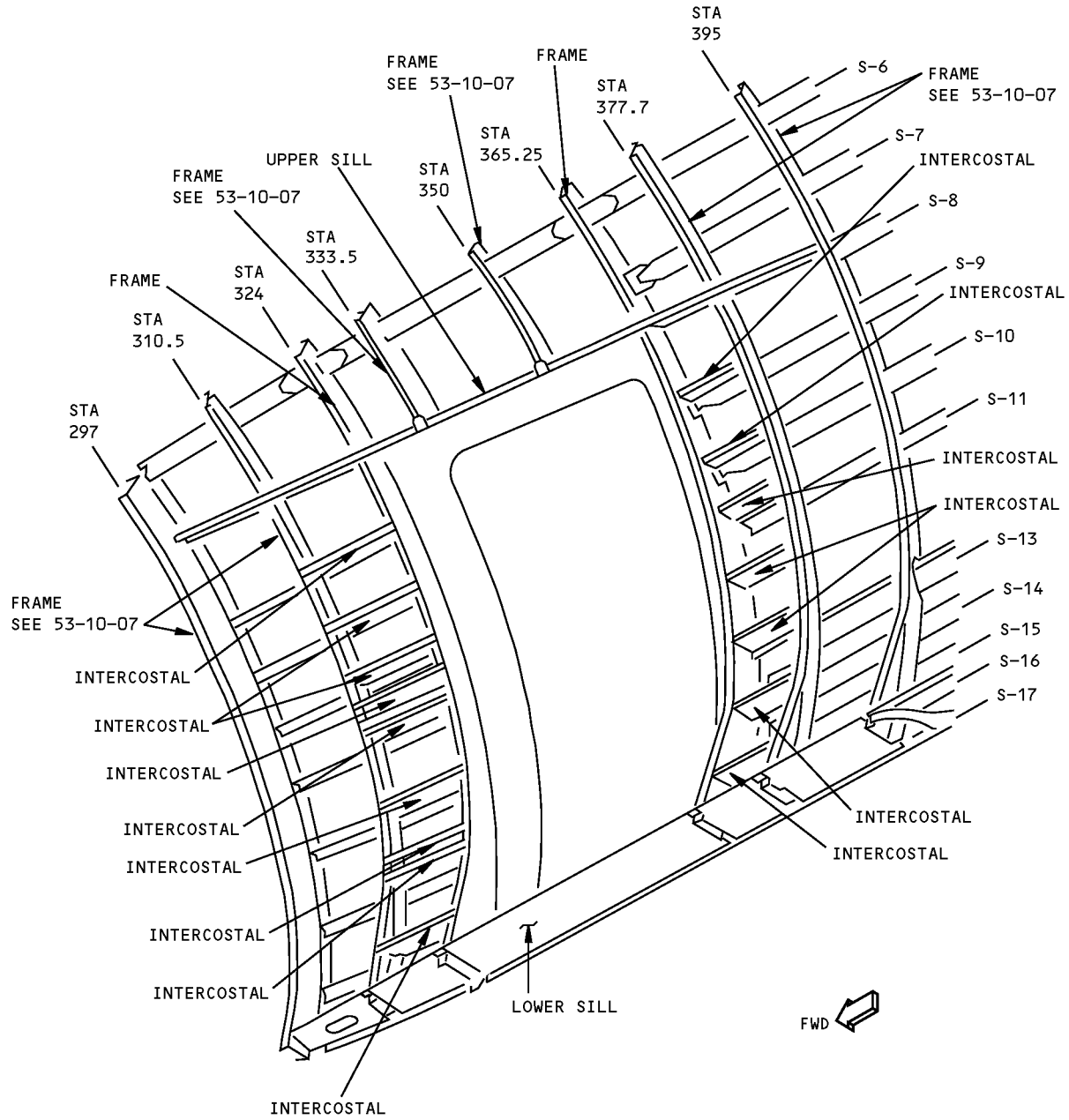
**757-200
STRUCTURAL REPAIR MANUAL**



**LEFT SIDE
DETAIL I**

**Section 41 Door Surround Structure Repair
Figure 201 (Sheet 2 of 3)**

**757-200
STRUCTURAL REPAIR MANUAL**



**RIGHT SIDE
DETAIL II**

**Section 41 Door Surround Structure Repair
Figure 201 (Sheet 3 of 3)**

D634N201

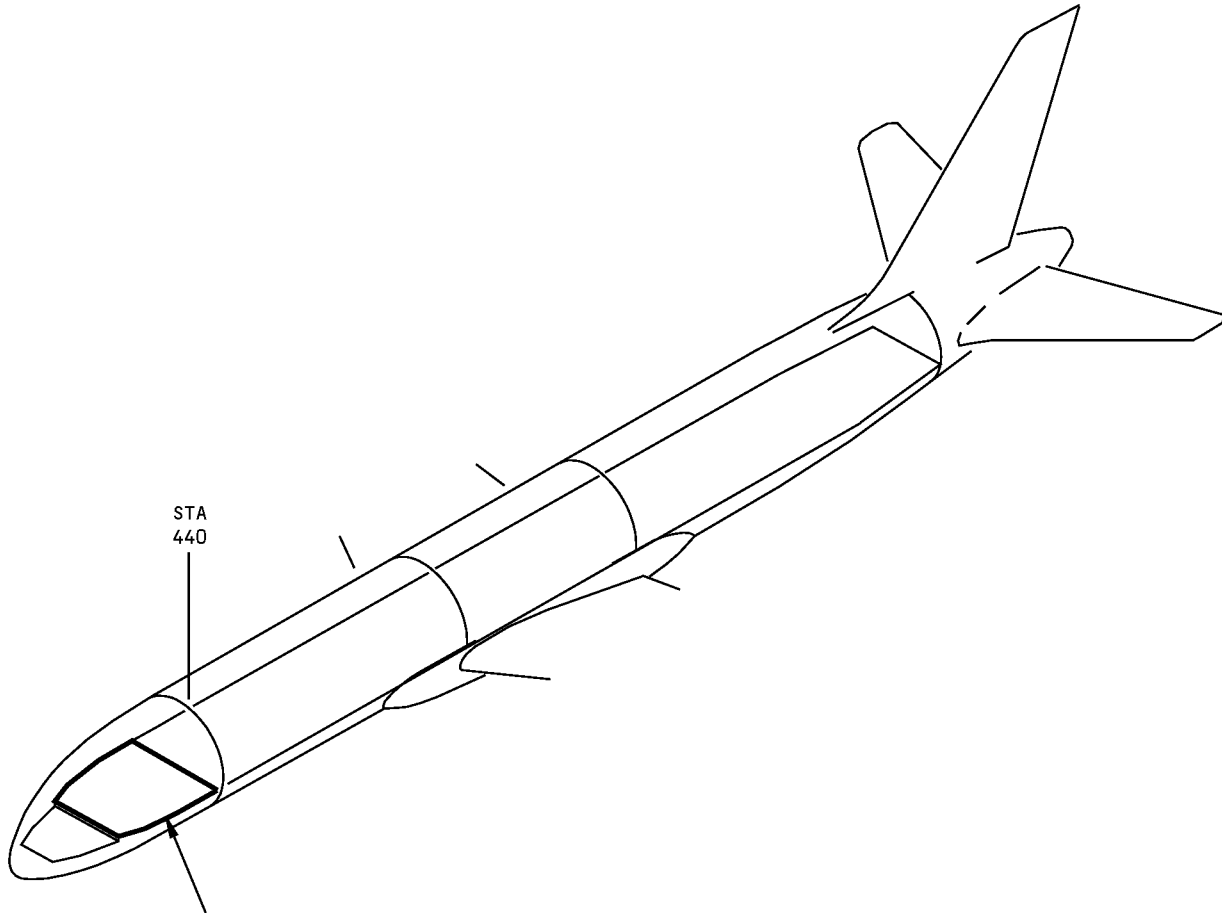
53-10-15

REPAIR GENERAL
Page 203
Jan 20/2005



757-200
STRUCTURAL REPAIR MANUAL

IDENTIFICATION GENERAL - SECTION 41 - MAIN DECK FLOOR PANELS



FOR FLOOR PANEL IDENTIFICATION
THIS SECTION SEE 53-00-50

Section 41 Main Deck Floor Panel Identification
Figure 1

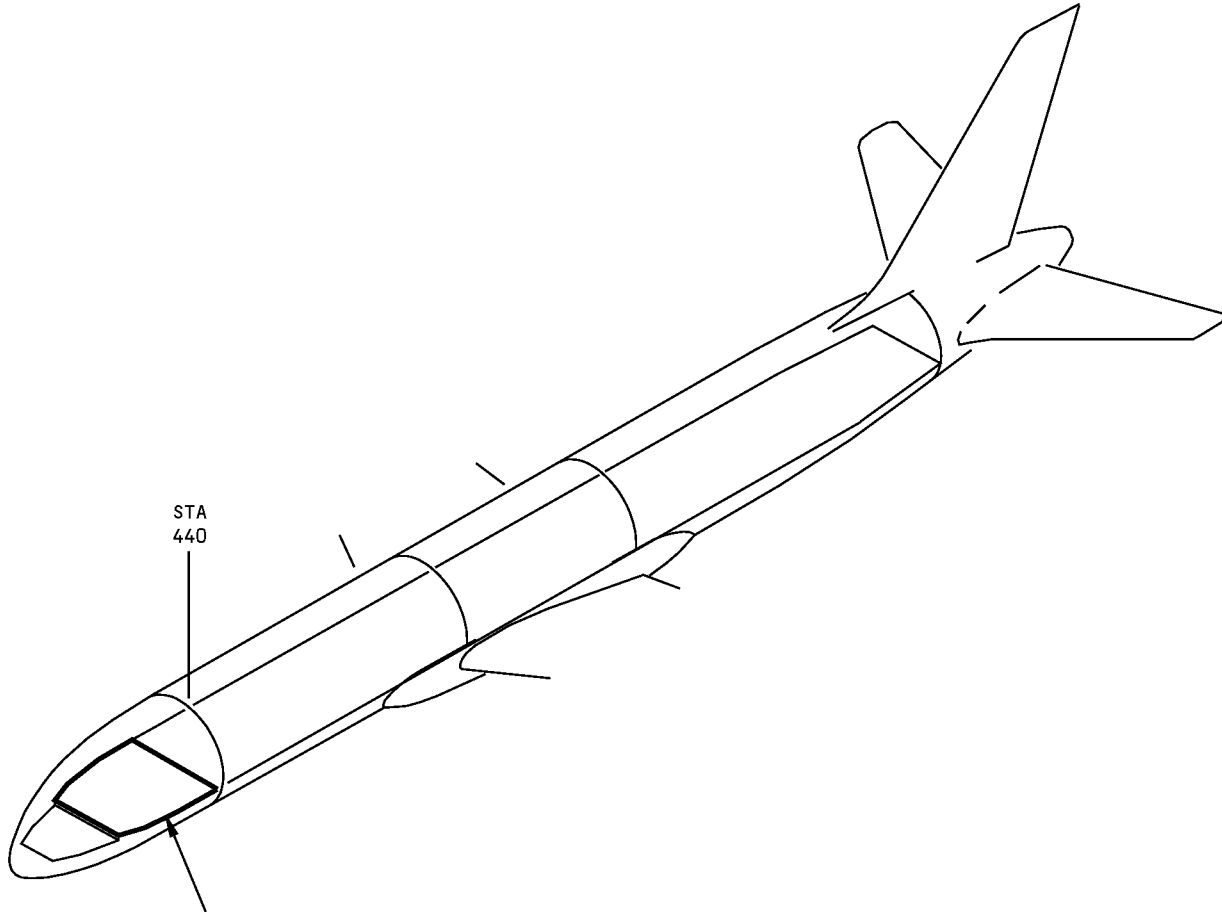
D634N201

IDENTIFICATION GENERAL
Page 1
53-10-50 Jan 20/2005



757-200
STRUCTURAL REPAIR MANUAL

ALLOWABLE DAMAGE GENERAL - SECTION 41 - MAIN DECK FLOOR PANELS



FOR FLOOR PANEL ALLOWABLE DAMAGE
THIS SECTION, SEE 53-00-50

Section 41 Main Deck Floor Panel Allowable Damage
Figure 101

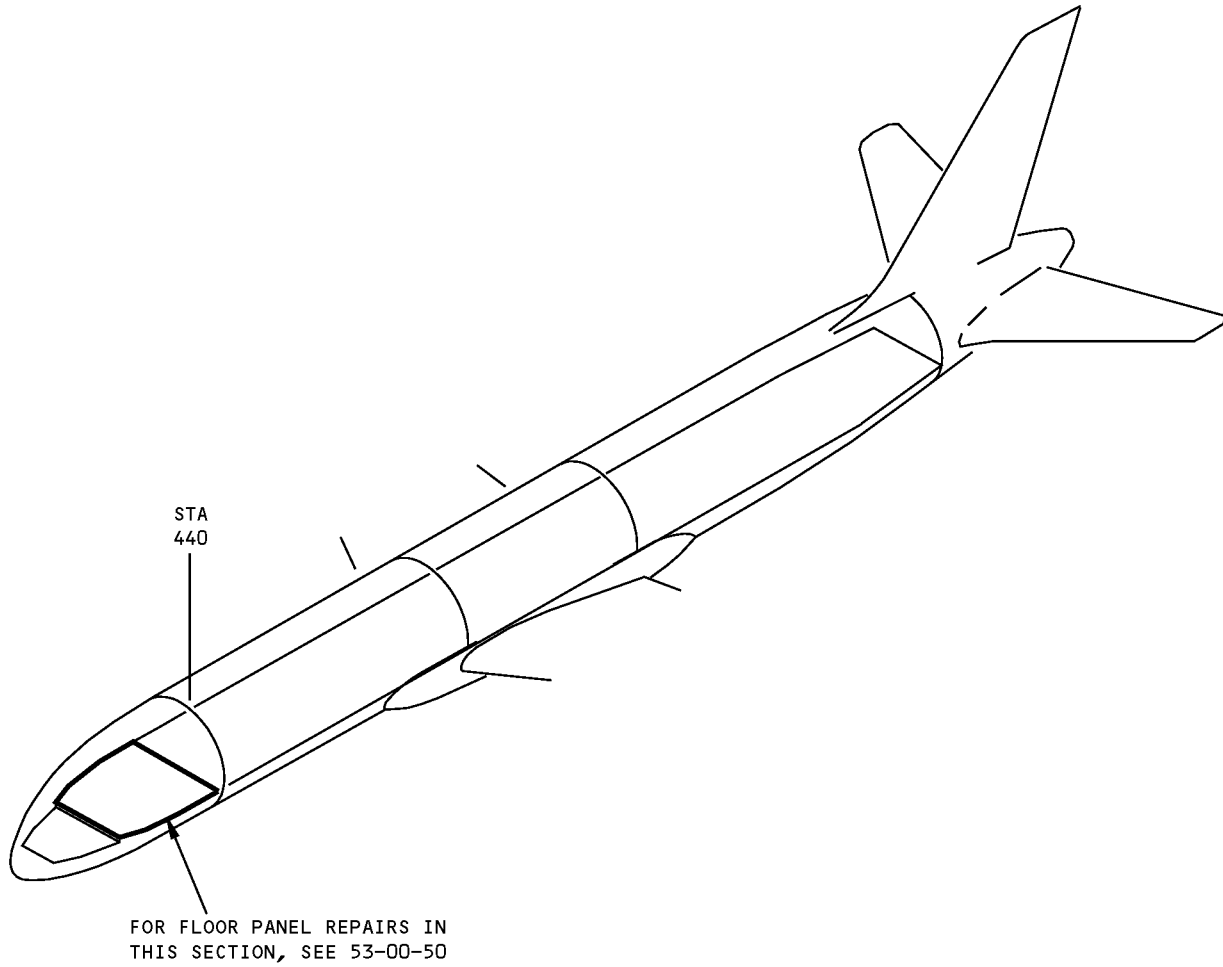
D634N201

ALLOWABLE DAMAGE GENERAL
53-10-50 Page 101
Jan 20/2005



757-200
STRUCTURAL REPAIR MANUAL

REPAIR GENERAL - SECTION 41 - MAIN DECK FLOOR PANEL REPAIRS



Section 41 Main Deck Floor Panel Repairs
Figure 201

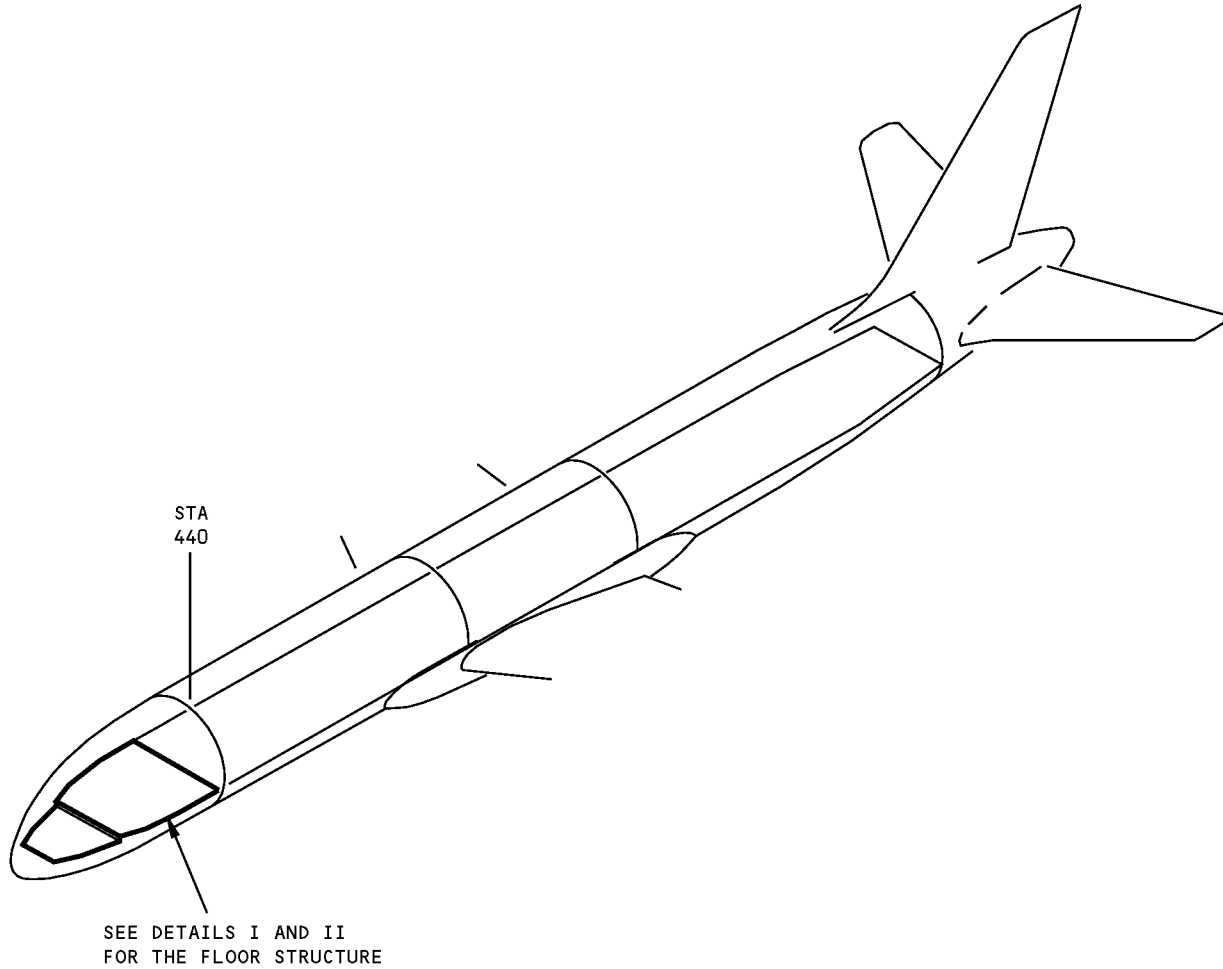
D634N201

53-10-50

REPAIR GENERAL
Page 201
Jan 20/2005

757-200
STRUCTURAL REPAIR MANUAL

IDENTIFICATION 1 - SECTION 41 - MAIN DECK FLOOR STRUCTURE



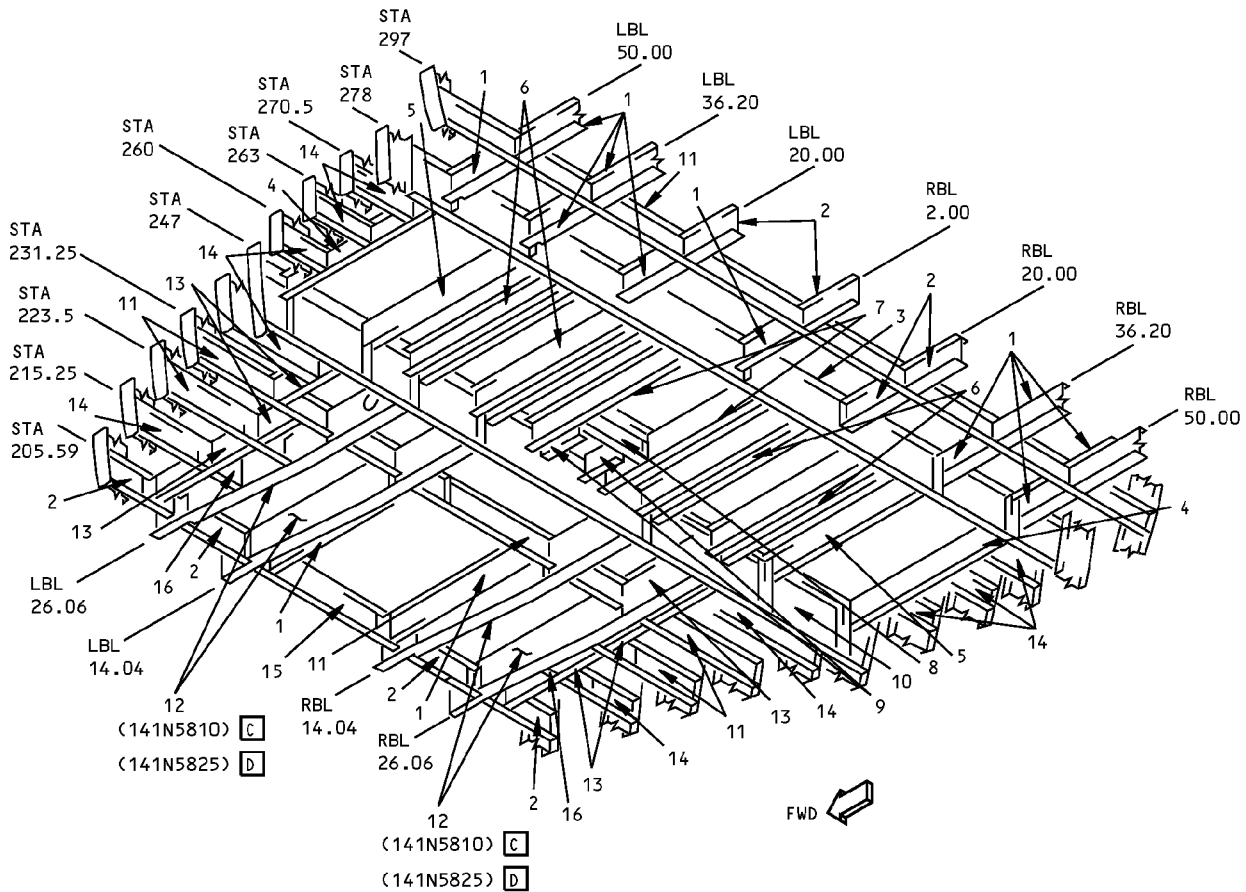
NOTES

- A** FOR CUM LINE NUMBERS:
1 THRU 5
- B** FOR CUM LINE NUMBERS:
6 AND ON
- C** FOR CUM LINE NUMBERS:
1 THRU 804
- D** FOR CUM LINE NUMBERS:
805 AND ON
- E** FOR 757-SF AIRPLANES ONLY

Section 41 Main Deck Floor Structure Identification
Figure 1 (Sheet 1 of 6)

**757-200
STRUCTURAL REPAIR MANUAL**

REFERENCE DRAWING
141N5810
141N5825



VIEW LOOKING UP AND FORWARD
DETAIL I

LIST OF
MATERIALS

**Section 41 Main Deck Floor Structure Identification
Figure 1 (Sheet 2 of 6)**

IDENTIFICATION 1
Page 2
Jan 20/2005

53-10-51

D634N201



**757-200
STRUCTURAL REPAIR MANUAL**

ITEM	DESCRIPTION	GAGE	MATERIAL	EFFECTIVITY
1	FLOOR BEAM		BAC1506-1691 7075-T6511	
2	FLOOR BEAM		BAC1509-100192 7075-T6511	
3	FLOOR BEAM		BAC1506-3356 7075-T6511	
4	INTERCOSTAL		BAC1493-720 7075-T6	
5	INTERCOSTAL		BAC1493-711 7075-T6	
6	FLOOR BEAM		(2) BAC1508-228 7075-T6511	
7	FLOOR BEAM		BAC1506-3401 7075-T6511	
8	INTERCOSTAL		BAC1490-2734 7075-T6	
9	INTERCOSTAL		BAC1517-1307 7075-T6	
10	FLOOR BEAM UPPER CHORD WEB LOWER CHORD	0.040	BAC1506-3356 7075-T6511 CLAD 7075-T6 AND10134-1205 7075-T6511	
11	FLOOR BEAM		BAC1506-3307 7075-T6511 7050-T7451 MACHINED PLATE	C D
12	FLOOR BEAM UPPER CHORD WEB LOWER CHORD	0.040	BAC1505-100864 7075-T6511 7050-T7451 MACHINED PLATE CLAD 7075-T6 AND10136-2005 7075-T6511 7050-T7451 MACHINED PLATE	C D C D
13	INTERCOSTAL		BAC1493-698 CLAD 7075-T6	
14	INTERCOSTAL		BAC1493-705 CLAD 7075-T6	
15	FLOOR BEAM UPPER CHORD WEB	0.040	BAC1490-2766 CLAD 7075-T6 CLAD 7075-T6	
16	INTERCOSTAL		BAC1514-2295 7075-T6511	

LIST OF MATERIALS FOR DETAIL I

**Section 41 Main Deck Floor Structure Identification
Figure 1 (Sheet 3 of 6)**

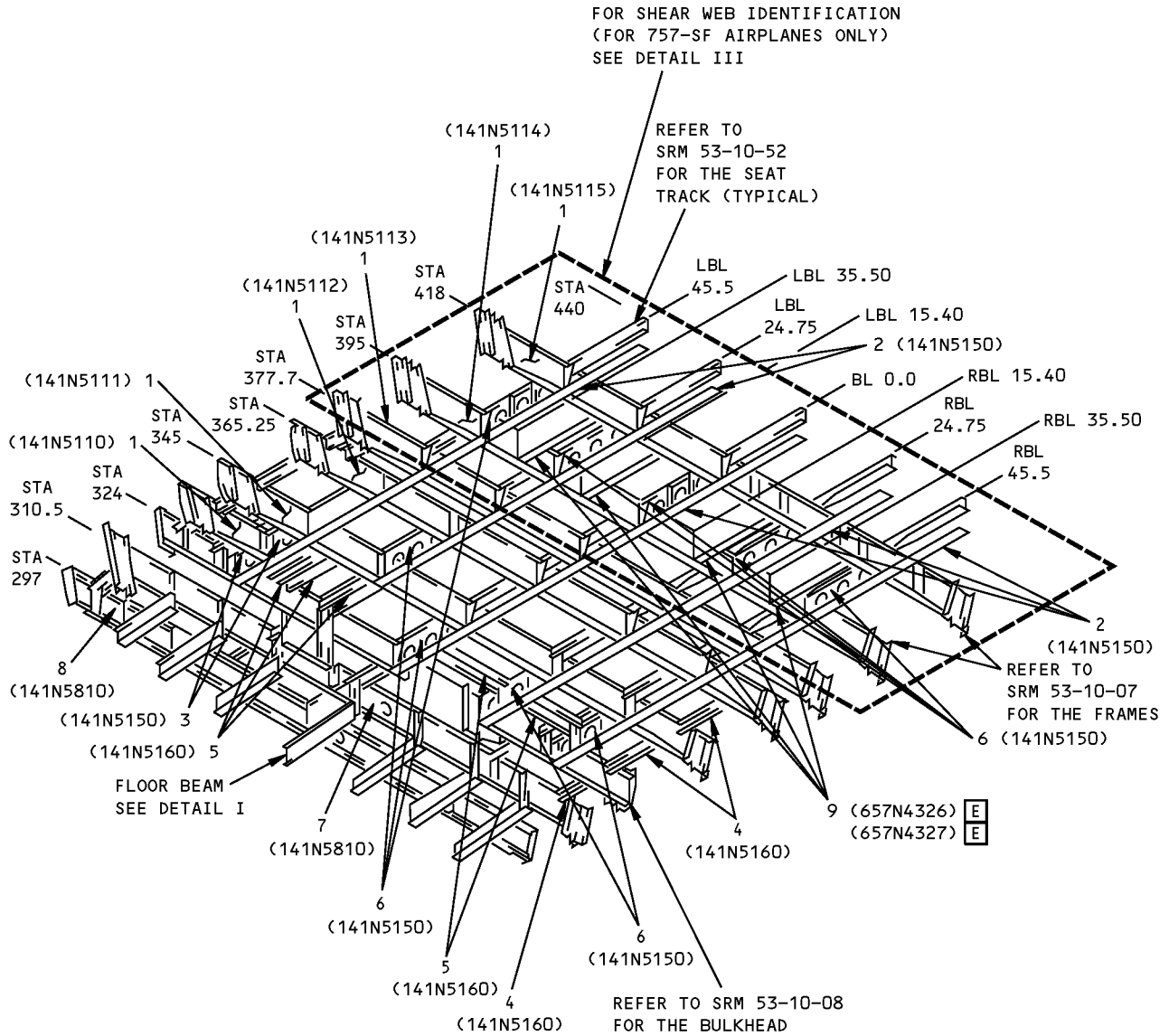
IDENTIFICATION 1
Page 3
Jan 20/2005

53-10-51

D634N201

**757-200
STRUCTURAL REPAIR MANUAL**

REFERENCE DRAWING
141N5100
657N3391 **E**



FWD

VIEW LOOKING UP AND FORWARD
DETAIL II

**LIST OF
MATL**

**Section 41 Main Deck Floor Structure Identification
Figure 1 (Sheet 4 of 6)**

IDENTIFICATION 1
Page 4
Jan 20/2005

53-10-51

D634N201



**757-200
STRUCTURAL REPAIR MANUAL**

ITEM	DESCRIPTION	GAGE	MATERIAL	EFFECTIVITY
1	FLOOR BEAM		BAC1518-338 7075-T6511	
2	CHANNEL		BAC1493-577 7075-T6	
3	INTERCOSTAL	0.032	CLAD 7075-T6	
4	ANGLE		BAC1490-2503 7075-T6	
5	CHANNEL		BAC1500-6236 7075-T6	
6	INTERCOSTAL	0.025	CLAD 7075-T6	
7	FLOOR BEAM			
	UPPER CHORD		AND10136-2005 7075-T6511	
	WEB	0.040	CLAD 7075-T6	
	LOWER CHORD		BAC1514-488 7075-T6511	
8	FLOOR BEAM			
	UPPER CHORD		AND10133-1202 7075-T6511	
	WEB	0.040	CLAD 7075-T6	A
	WEB	0.032	CLAD 7075-T6	B
9	INTERCOSTAL			
	LOWER CHORD		BAC1505-101397 7075-T6511	E
	WEB	0.040	CLAD 7075-T6	E

LIST OF MATERIALS FOR DETAIL II

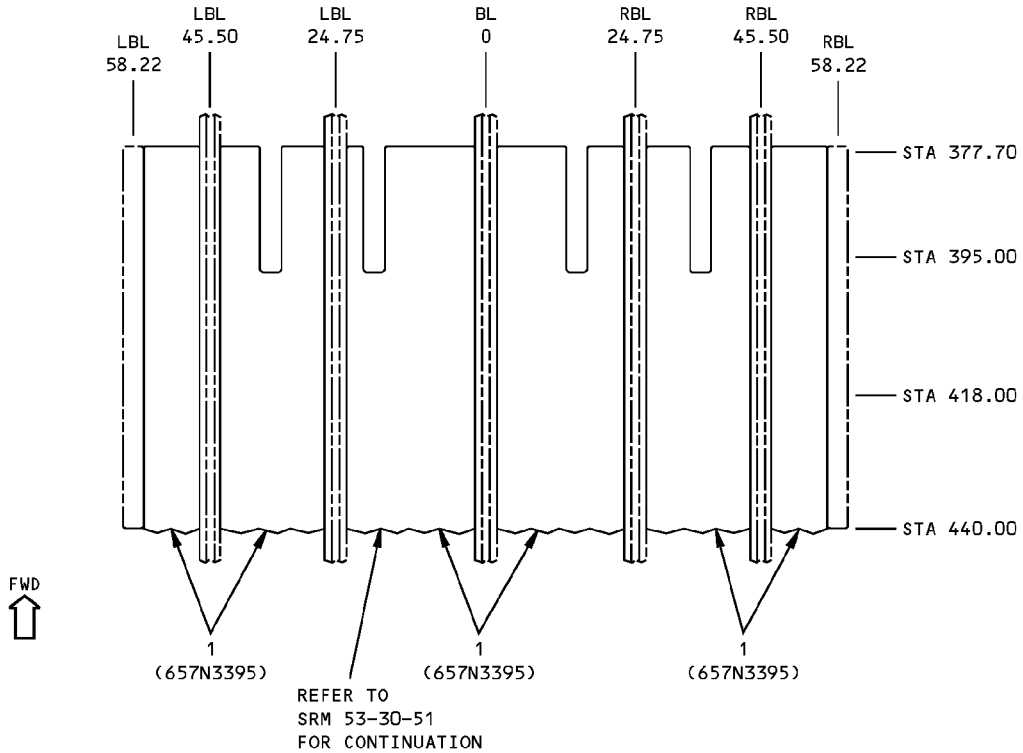
**Section 41 Main Deck Floor Structure Identification
Figure 1 (Sheet 5 of 6)**

IDENTIFICATION 1
Page 5
Jan 20/2005

53-10-51

D634N201

**757-200
STRUCTURAL REPAIR MANUAL**



**SHEAR WEB IDENTIFICATION
DETAIL III
(757-SF AIRPLANES ONLY)**

ITEM	DESCRIPTION	GAGE	MATERIAL	EFFECTIVITY
1	SHEAR WEB	0.100	CLAD 7075-T6	

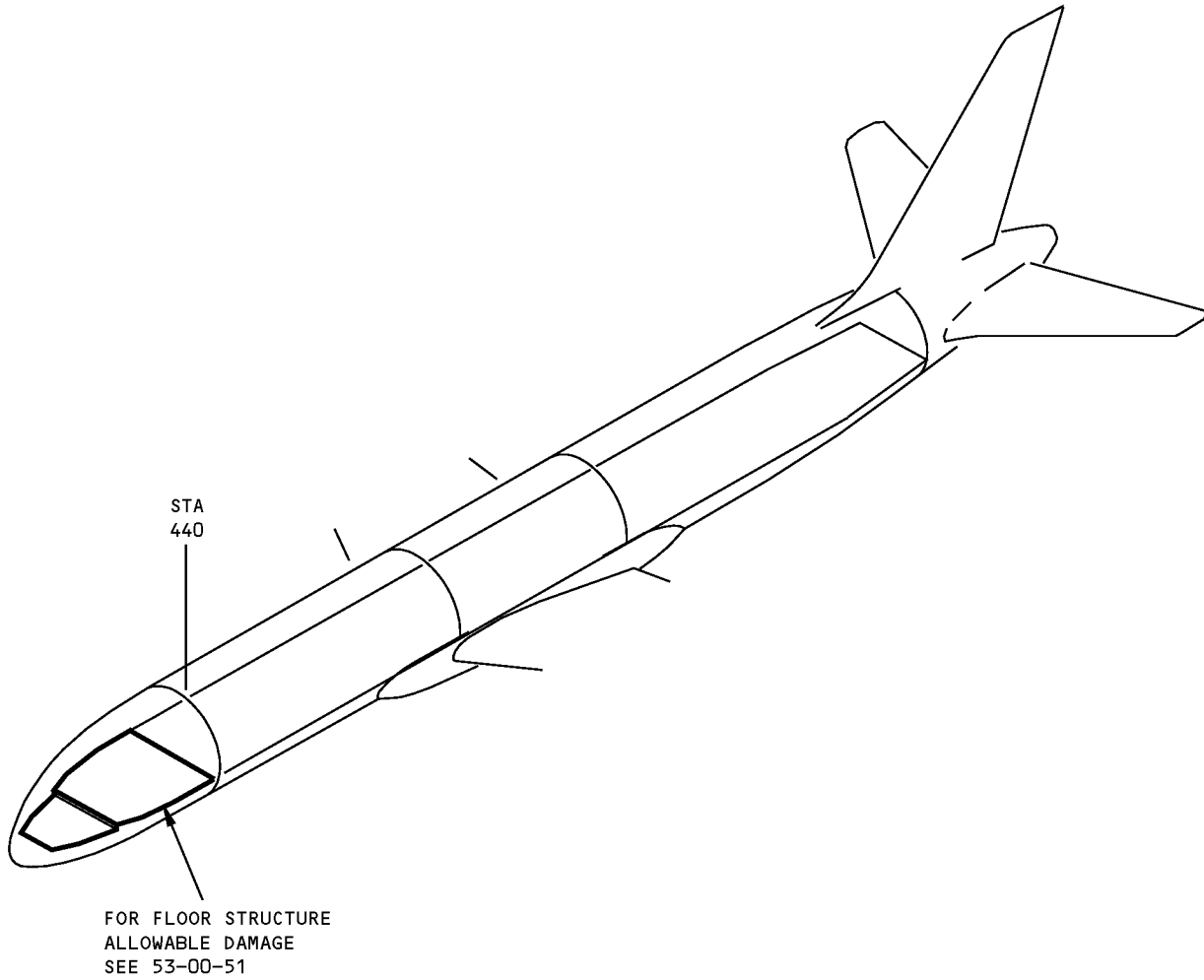
LIST OF MATERIALS FOR DETAIL III

**Section 41 Main Deck Floor Structure Identification
Figure 1 (Sheet 6 of 6)**



757-200
STRUCTURAL REPAIR MANUAL

ALLOWABLE DAMAGE GENERAL - SECTION 41 - MAIN DECK FLOOR STRUCTURE



Section 41 Main Deck Floor Structure Allowable Damage
Figure 101

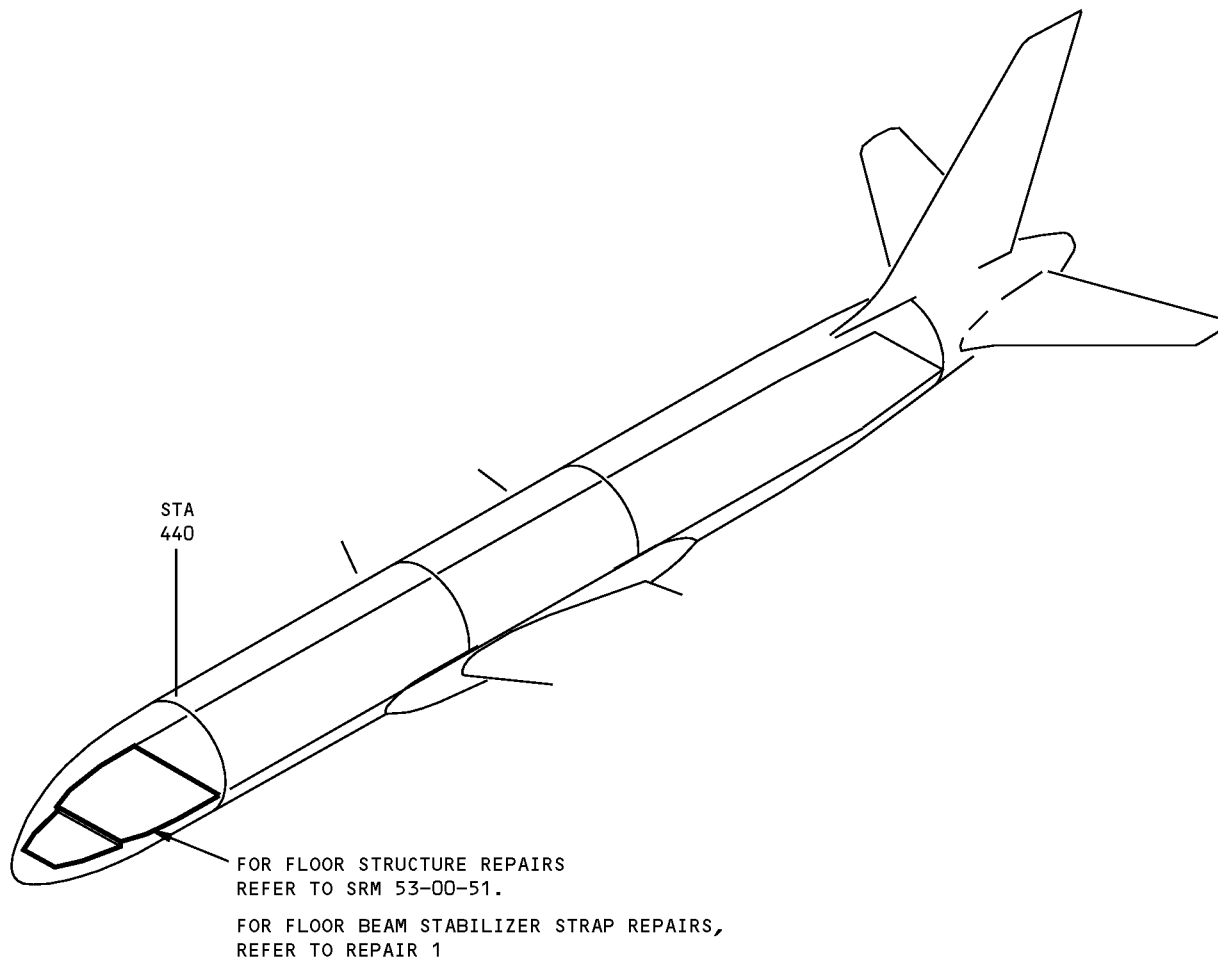
D634N201

ALLOWABLE DAMAGE GENERAL
53-10-51
Page 101
Jan 20/2007



757-200
STRUCTURAL REPAIR MANUAL

REPAIR GENERAL - SECTION 41 - MAIN DECK FLOOR STRUCTURE



Section 41 Main Deck Floor Structure Repair
Figure 201

D634N201

53-10-51

REPAIR GENERAL
Page 201
Jan 20/2005

STRUCTURAL REPAIR MANUAL

REPAIR 1 - SECTION 41 - FLOOR STRUCTURE STABILIZER STRAP CRACK REPAIR

REPAIR INSTRUCTIONS

1. Remove the fasteners in the repair area that attach the stabilizer strap to the floor beam.
2. Drill a 0.25 inch (6 mm) diameter stop hole in the stabilizer strap at each end of the crack that does not stop at an edge.
3. Make the part 1 plate. See Table I. See Details I thru V for a repair near the end of a stabilizer strap. See Detail VI for a repair at floor beam locations between the ends of a stabilizer strap.
4. Put the part 1 plate on the stabilizer strap and drill the fastener holes. Keep a 0.38 inch (9.7 mm) minimum edge margin between:
 - The fastener holes and the edges of the part 1 plate
 - The fastener holes and the crack
 - The fastener holes and the crack stop holes.
5. Remove the part 1 plate.
6. Remove the nicks, scratches, gouges, burrs, and sharp edges from the stabilizer strap and the part 1 plate.
7. Apply a chemical conversion coating to the part 1 plate and the bare edges of the crack in the stabilizer strap. Refer to SRM 51-20-01.
8. Apply two layers of BMS 10-11, Type 1 primer to the part 1 plate and the bare edges of the stabilizer strap. Refer to SOPM 20-41-02.
9. Install the part 1 plate with BMS 5-95 sealant between the mating surfaces. Refer to SRM 51-20-05.
10. Install fasteners. Fasteners that are not made of aluminum must be installed wet with BMS 5-95 sealant. Refer to SRM 51-20-05.
11. Apply two layers of BMS 10-60, Type II enamel to the repair area. Refer to AMM 51-21.

NOTES

- THIS IS A CATEGORY A REPAIR FOR 757-SF AIRPLANES. THE INSPECTIONS GIVEN IN THE MAINTENANCE PLANNING DATA (MPD) ARE SUFFICIENT TO MAINTAIN THE DAMAGE TOLERANCE OF THE INITIAL STRUCTURE WITH THIS REPAIR INSTALLED. REFER TO SRM 51-00-06 FOR REPAIR CATEGORIES AND DEFINITIONS.
- WHEN YOU USE THIS REPAIR REFER TO:
 - AMM 51-21 FOR INTERIOR AND EXTERIOR FINISHES
 - SOPM 20-41-02 FOR THE APPLICATION OF CHEMICAL AND SOLVENT RESISTANT FINISHES
 - SRM 51-10-02 FOR INSPECTION AND REMOVAL OF DAMAGE
 - SRM 51-20-01 FOR PROTECTIVE TREATMENT OF METAL
 - SRM 51-20-05 FOR REPAIR SEALING
 - SRM 51-40 FOR FASTENER CODE, REMOVAL, INSTALLATION, HOLE SIZES AND EDGE MARGINS.

A REMOVE THE FASTENER FROM THIS LOCATION. DO NOT FILL THE HOLE.

B CUT THE DAMAGED STABILIZER STRAP AT THIS LOCATION. REMOVE THE SHARP EDGES FROM THE CUT EDGES OF THE STABILIZER STRAP. KEEP THE CUT END OF THE STRAP FOR USE AS A FILLER.

FASTENER SYMBOLS

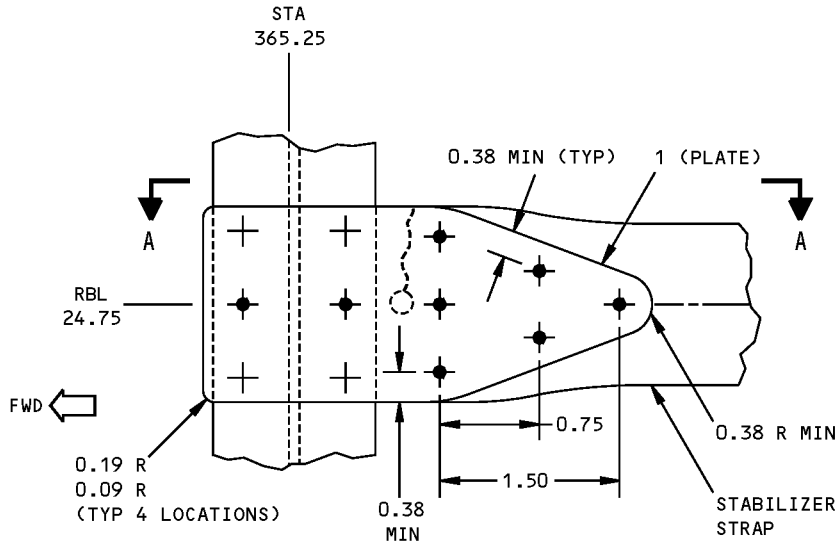
- ⊥ REPAIR FASTENER LOCATION.
- ⊕ INITIAL FASTENER LOCATION. IF THE INITIAL FASTENER IS AN ALUMINUM ALLOY RIVET, INSTALL THE SAME SIZE AND TYPE FASTENER. IF THE INITIAL FASTENER IS A HEX DRIVE BOLT, INSTALL THE SAME TYPE FASTENER AND 1/64 INCH OVERSIZE.
- ✦ REPAIR FASTENER LOCATION. INSTALL A BACR15FT6D RIVET. KEEP AN EDGE MARGIN OF 2D FROM THE CRACK OR STOP DRILL HOLE.

REPAIR MATERIAL			
PART		QTY	MATERIAL
1	PLATE	1	0.040 2024-T3 WIDTH 2.4 INCHES (61 mm), LENGTH AND SHAPE AS NECESSARY

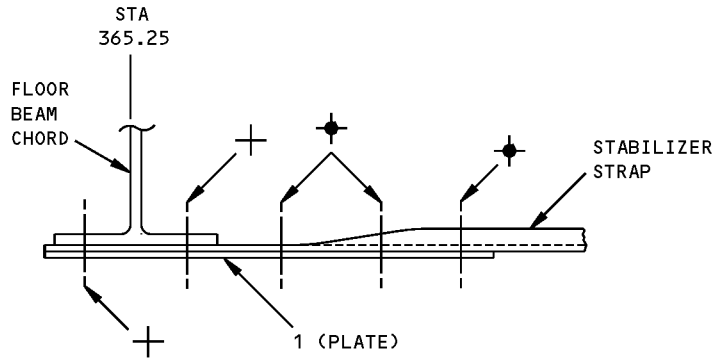
TABLE I

**Section 41 Floor Structure Stabilizer Strap Crack Repair
Figure 201 (Sheet 1 of 7)**

**757-200
STRUCTURAL REPAIR MANUAL**



VIEW IN THE UP DIRECTION

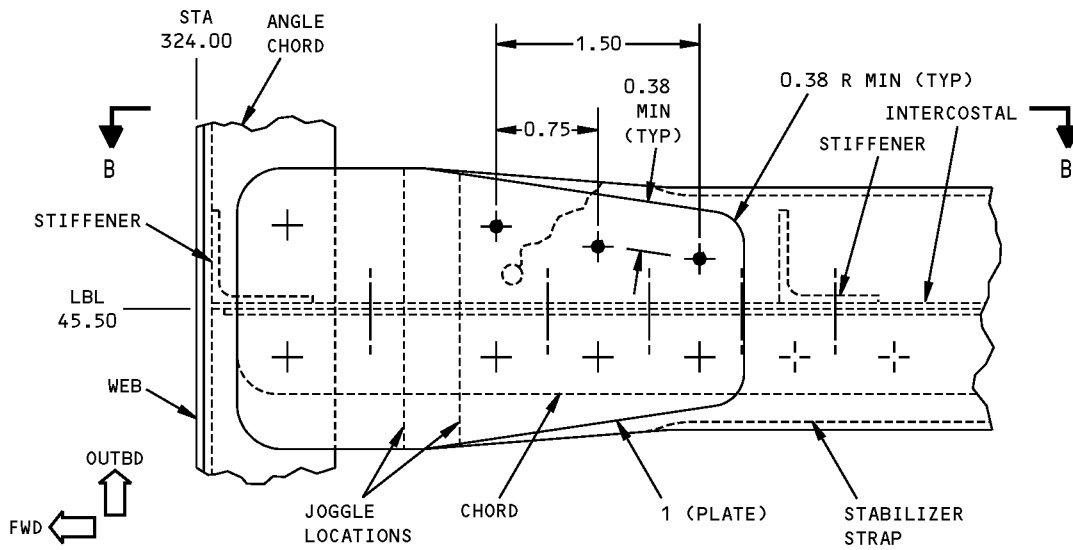


SECTION A-A

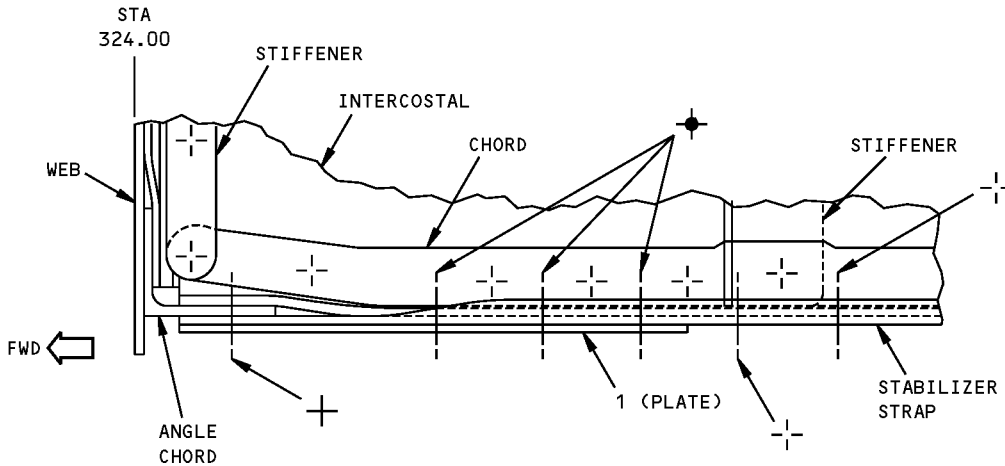
DETAIL I

**Section 41 Floor Structure Stabilizer Strap Crack Repair
Figure 201 (Sheet 2 of 7)**

**757-200
STRUCTURAL REPAIR MANUAL**



VIEW IN THE UP DIRECTION

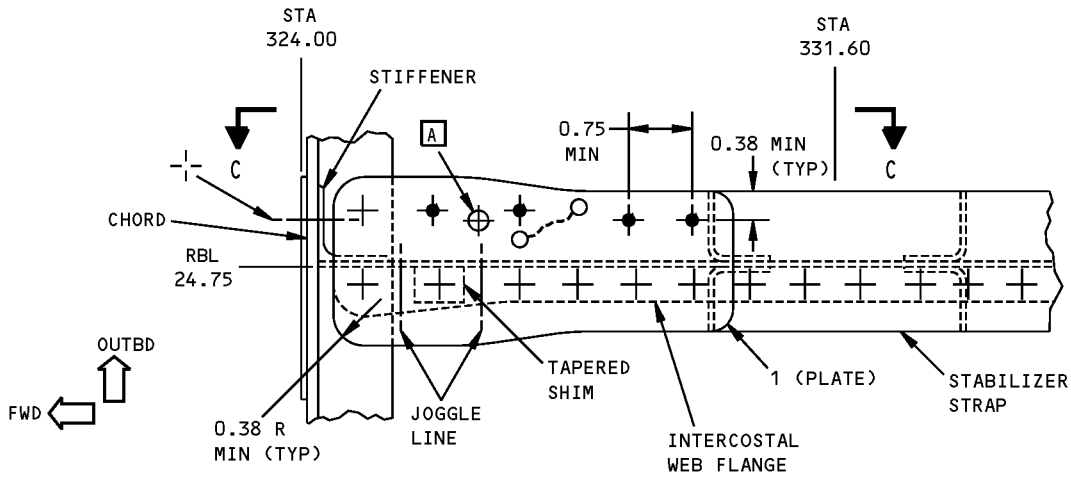


SECTION B-B

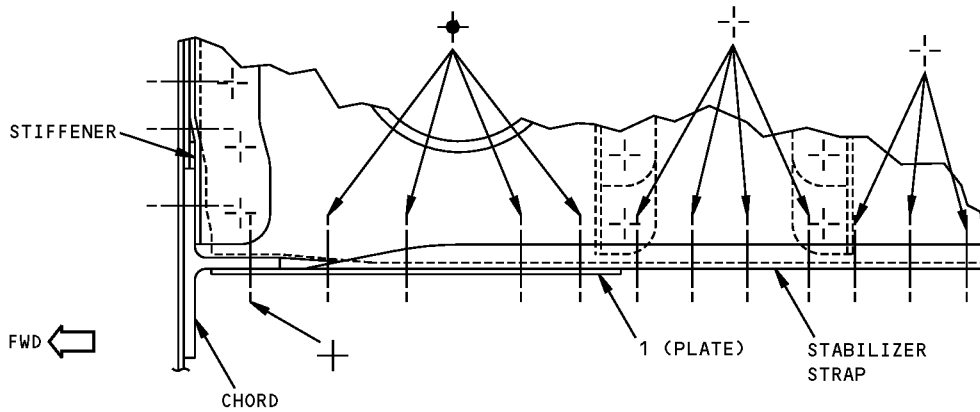
DETAIL II

**Section 41 Floor Structure Stabilizer Strap Crack Repair
Figure 201 (Sheet 3 of 7)**

**757-200
STRUCTURAL REPAIR MANUAL**



VIEW IN THE UP DIRECTION

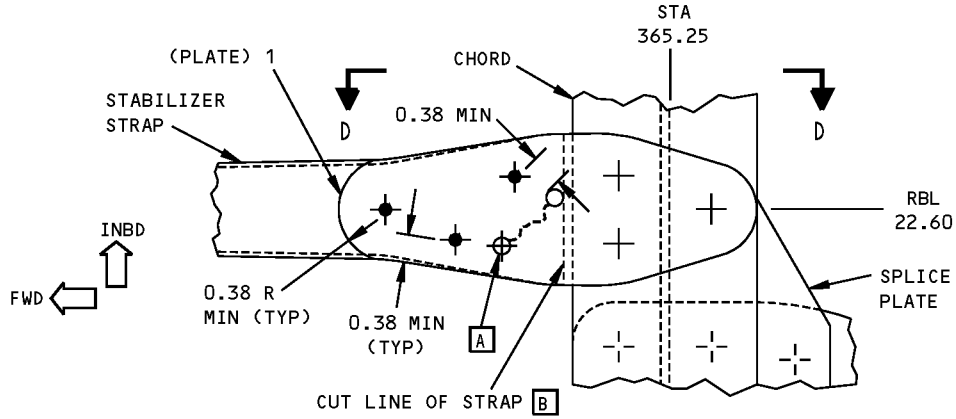


SECTION C-C

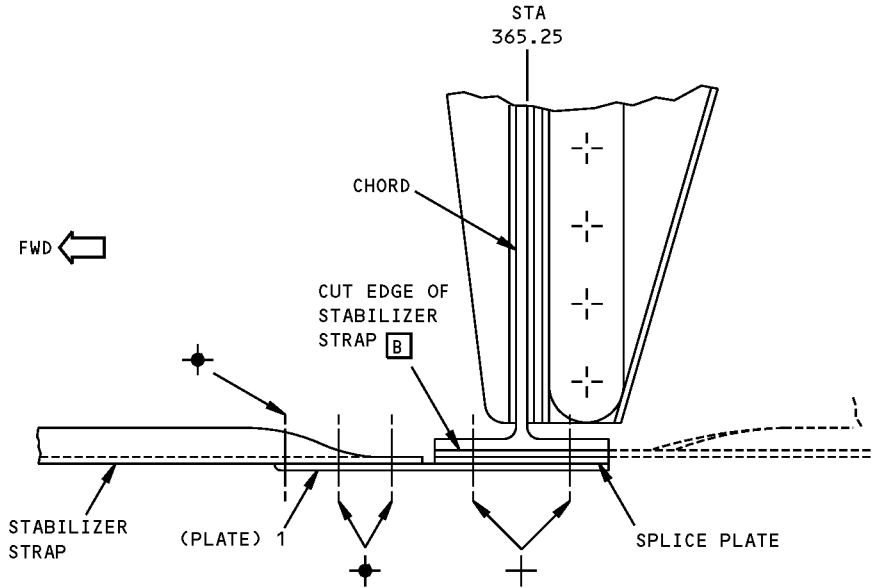
DETAIL III

**Section 41 Floor Structure Stabilizer Strap Crack Repair
Figure 201 (Sheet 4 of 7)**

**757-200
STRUCTURAL REPAIR MANUAL**



VIEW IN THE UP DIRECTION

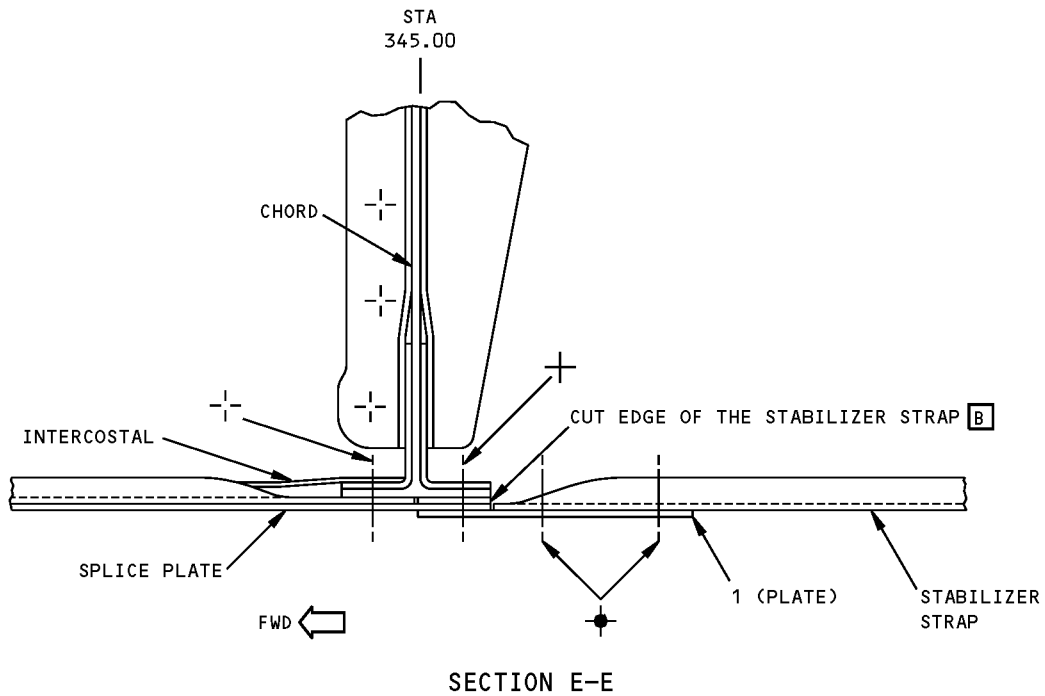
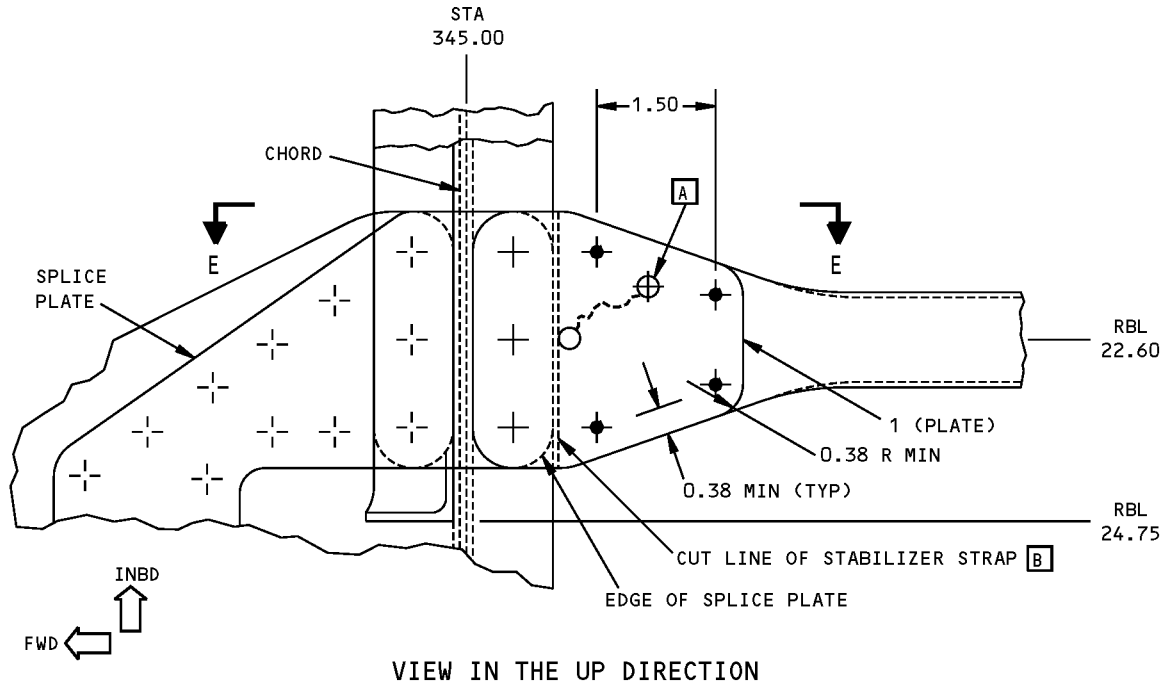


SECTION D-D

DETAIL IV

**Section 41 Floor Structure Stabilizer Strap Crack Repair
Figure 201 (Sheet 5 of 7)**

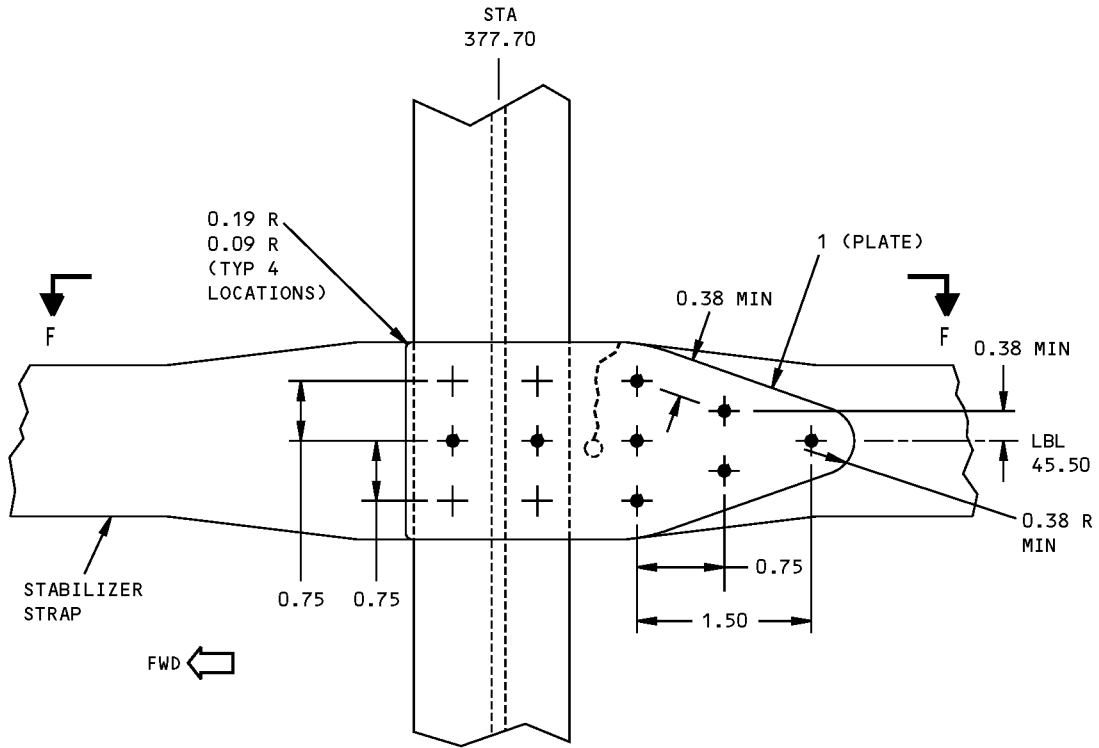
**757-200
STRUCTURAL REPAIR MANUAL**



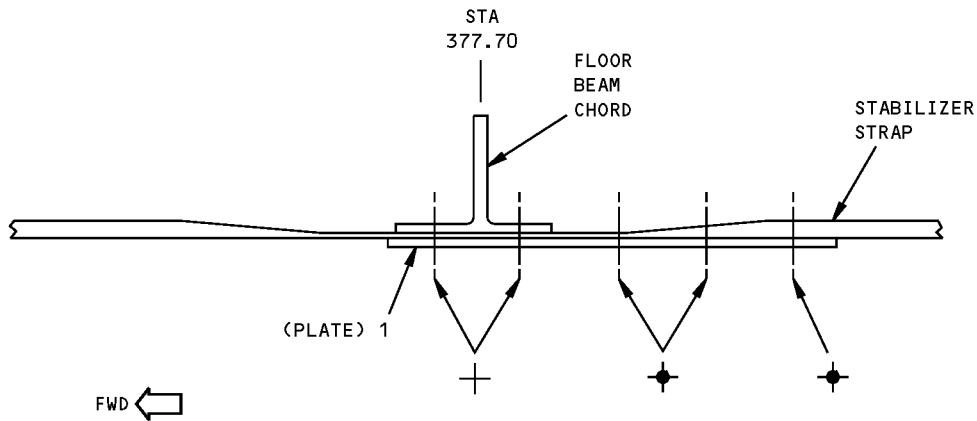
DETAIL V

**Section 41 Floor Structure Stabilizer Strap Crack Repair
Figure 201 (Sheet 6 of 7)**

**757-200
STRUCTURAL REPAIR MANUAL**



VIEW IN THE UP DIRECTION



SECTION F-F

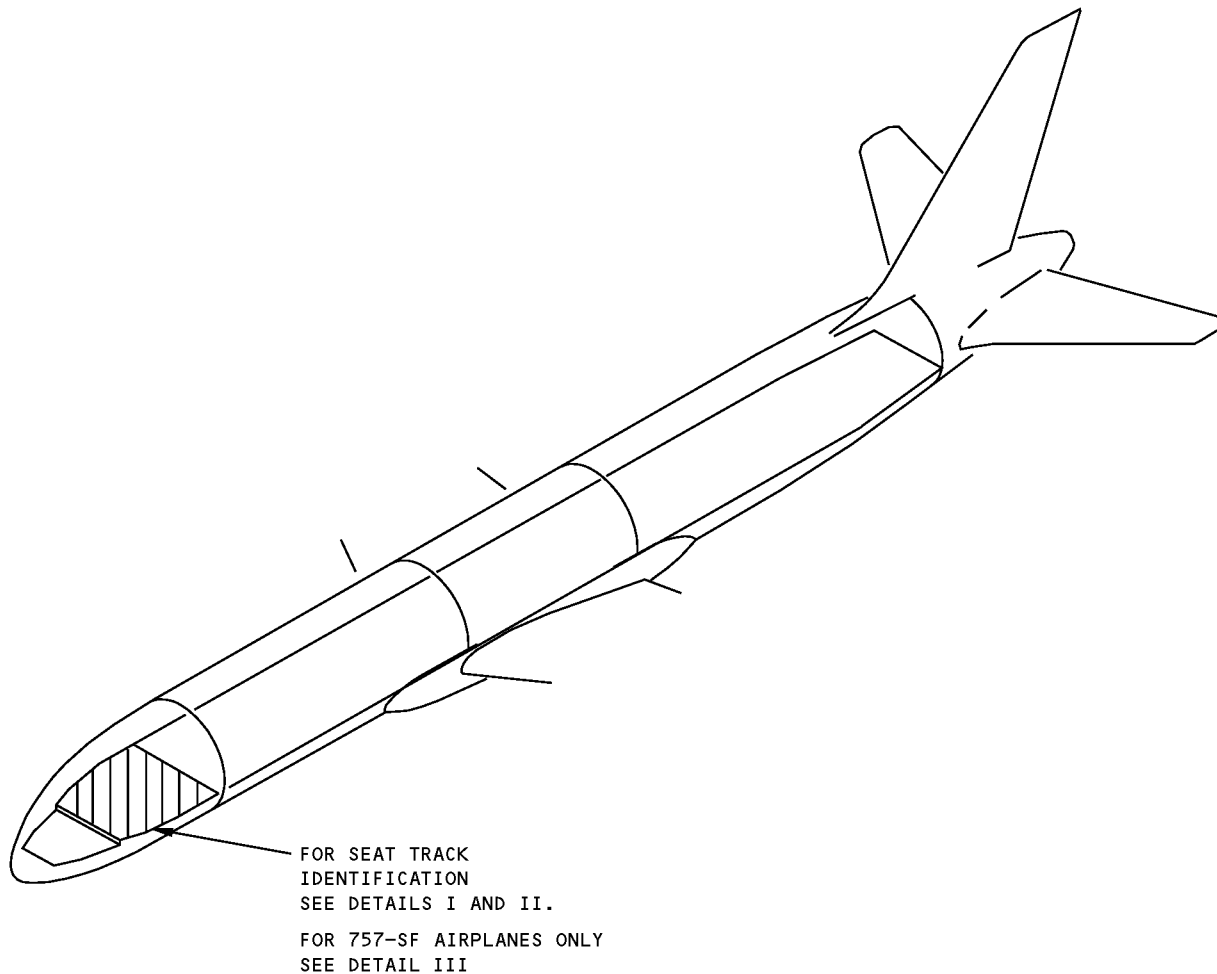
DETAIL VI

**Section 41 Floor Structure Stabilizer Strap Crack Repair
Figure 201 (Sheet 7 of 7)**

757-200
STRUCTURAL REPAIR MANUAL

IDENTIFICATION 1 - SECTION 41 - SEAT TRACKS

REFERENCE DRAWING
141N5130



NOTES

A SEAT TRACK CONFIGURATION DIFFER FROM BASIC IN AREAS SHOWN TO SUIT OPERATOR REQUIREMENTS. SEE DWG 141N5130 FOR INDIVIDUAL OPERATOR VARIABLE

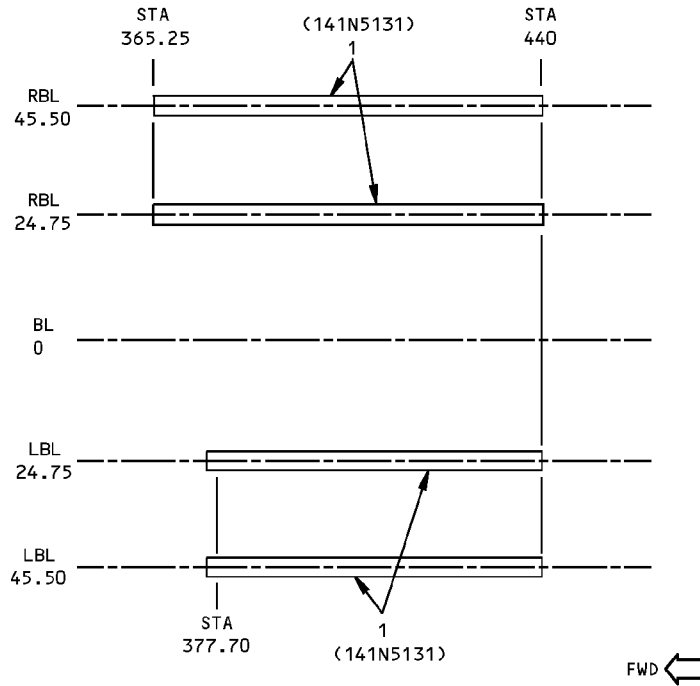
B FOR CUM LINE NUMBERS:
221,224
(BOEING REF: NA341-NA390,NA397-NA399)

C FOR CUM LINE NUMBERS:
9 THRU 11,13,14,16,23 THRU 25,29,30,32
THRU 34,50,52,54,57,58,63,77,78,81,89,90,
93,98,123,145,146,153,160,161,163,165 THRU
169,173 THRU 175,178,179,183,187,210,211,
214,218,225
(BOEING REF: NA194-NA199,NA201-NA340,
NA391-NA396,NB071-NB080,NB181-NB199)

Section 41 Seat Track Identification
Figure 1 (Sheet 1 of 4)

**757-200
STRUCTURAL REPAIR MANUAL**

REF DWG
141N5130



**BASIC CONFIGURATION
DETAIL I**

ITEM	DESCRIPTION	GAGE	MATERIAL	EFFECTIVITY
1	SEAT TRACK		BAC1520-792 7178-T6511	

LIST OF MATERIALS FOR DETAIL I

**Section 41 Seat Track Identification
Figure 1 (Sheet 2 of 4)**

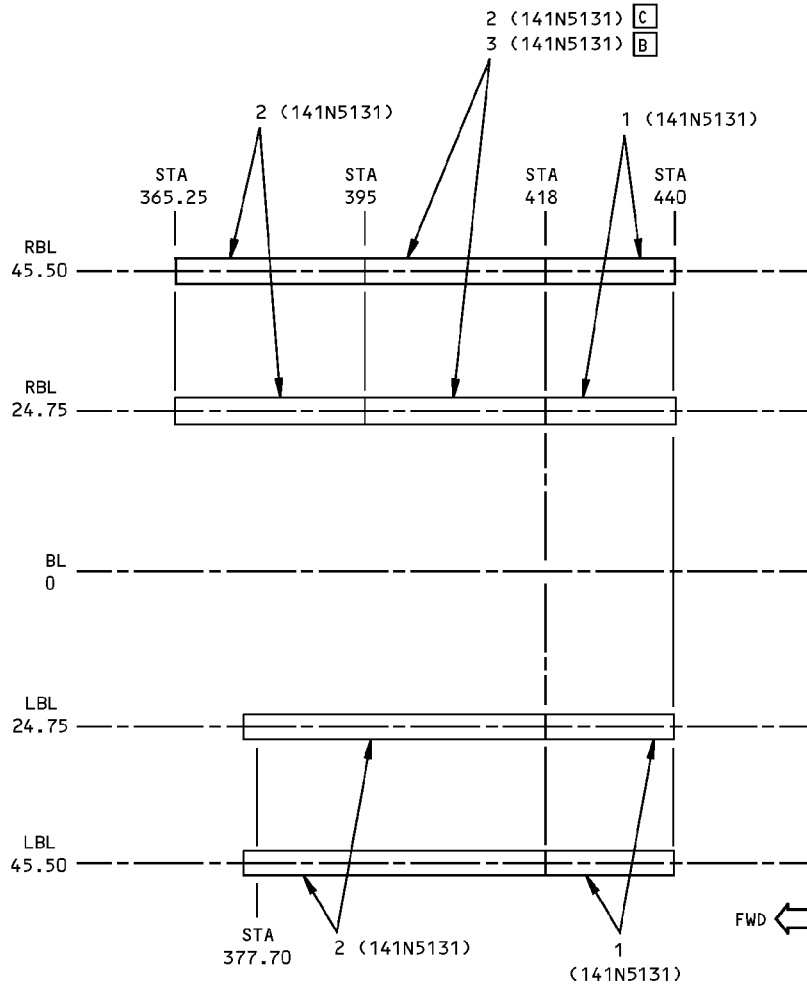
IDENTIFICATION 1
Page 2
Jan 20/2005

53-10-52

D634N201

**757-200
STRUCTURAL REPAIR MANUAL**

REF DWG
141N5130



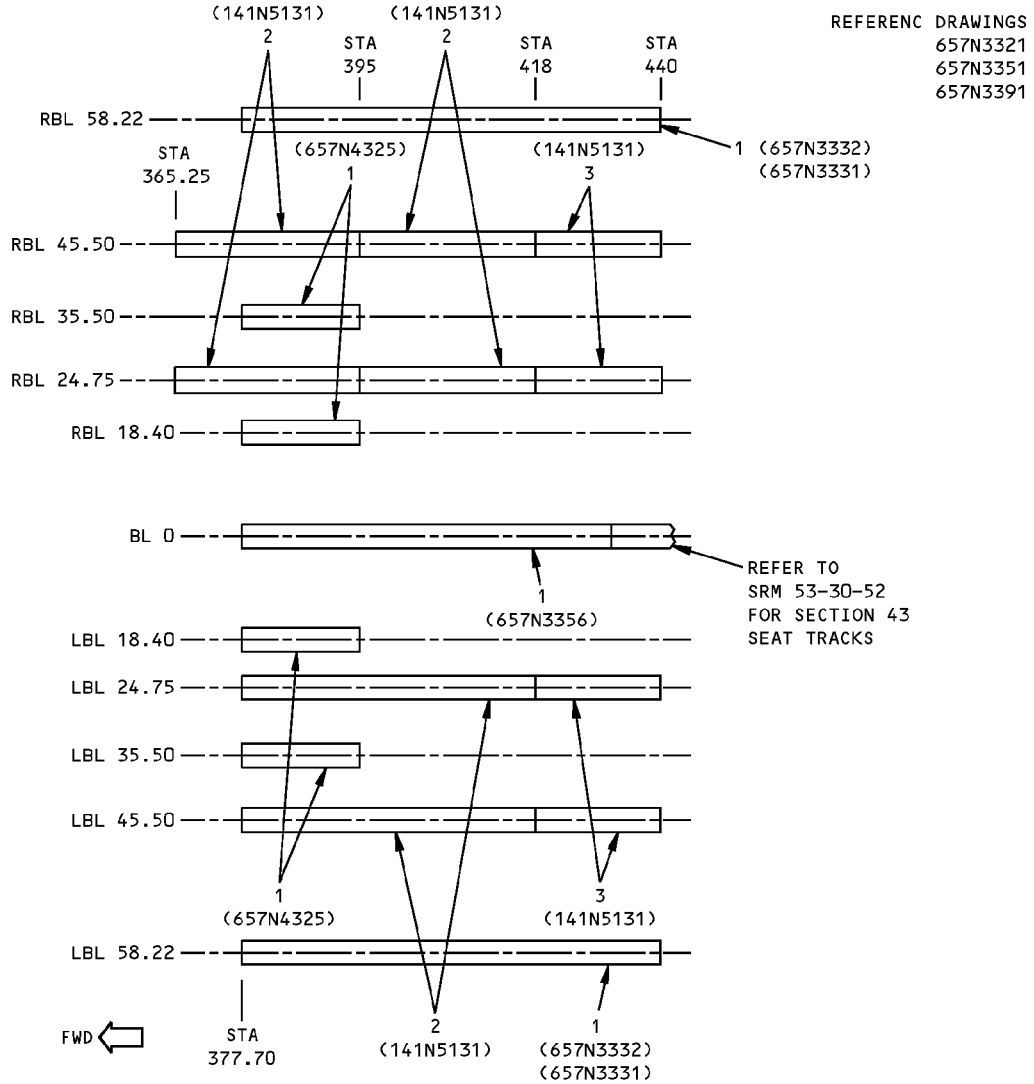
**VARIABLE CONFIGURATION [A]
DETAIL II**

ITEM	DESCRIPTION	GAGE	MATERIAL	EFFECTIVITY
1	SEAT TRACK		BAC1520-792 7178-T6511	
2	SEAT TRACK ASSEMBLY SEAT TRACK CROWN	0.50	15-5 PH CRES HT TR 150-170 [C] KSI	
	SEAT TRACK SUPPORT		BAC1508-237 7075-T6511	
3	SEAT TRACK ASSEMBLY SEAT TRACK CROWN		BAC1520-841 7178-T6511 [B]	
	SEAT TRACK SUPPORT		BAC1508-237 7075-T6511	

LIST OF MATERIALS FOR DETAIL II

**Section 41 Seat Track Identification
Figure 1 (Sheet 3 of 4)**

**757-200
STRUCTURAL REPAIR MANUAL**



**757-SF AIRPLANES ONLY
DETAIL III**

ITEM	DESCRIPTION	GAGE	MATERIAL	EFFECTIVITY
1	SEAT TRACK SEAT TRACK SUPPORT		BAC1520-792 7178-T6511 (ALTERED) BAC1508-237 7075-T6511	
2	SEAT TRACK ASSEMBLY SEAT TRACK CROWN	0.50	15-5 PH CRES HT TR 150-170 KSI	
	SEAT TRACK SUPPORT		BAC1508-237 7075-T6511	
3	SEAT TRACK		BAC1520-792 7178-T6511	

LIST OF MATERIALS FOR DETAIL III

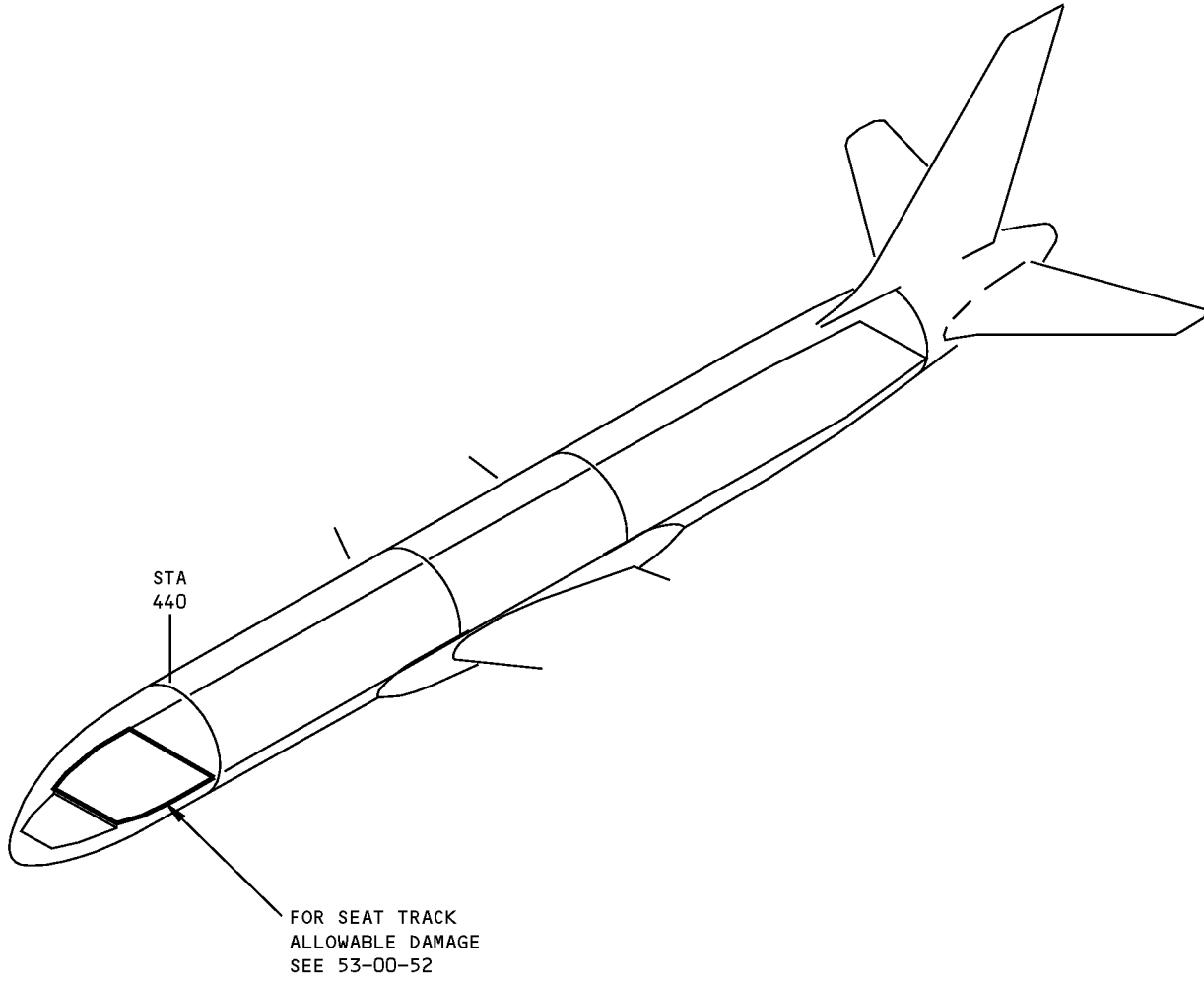
**Section 41 Seat Track Identification
Figure 1 (Sheet 4 of 4)**



757-200
STRUCTURAL REPAIR MANUAL

ALLOWABLE DAMAGE GENERAL - SECTION 41 - SEAT TRACKS

REF DWG
141N5130



Section 41 Seat Track Allowable Damage
Figure 101

D634N201

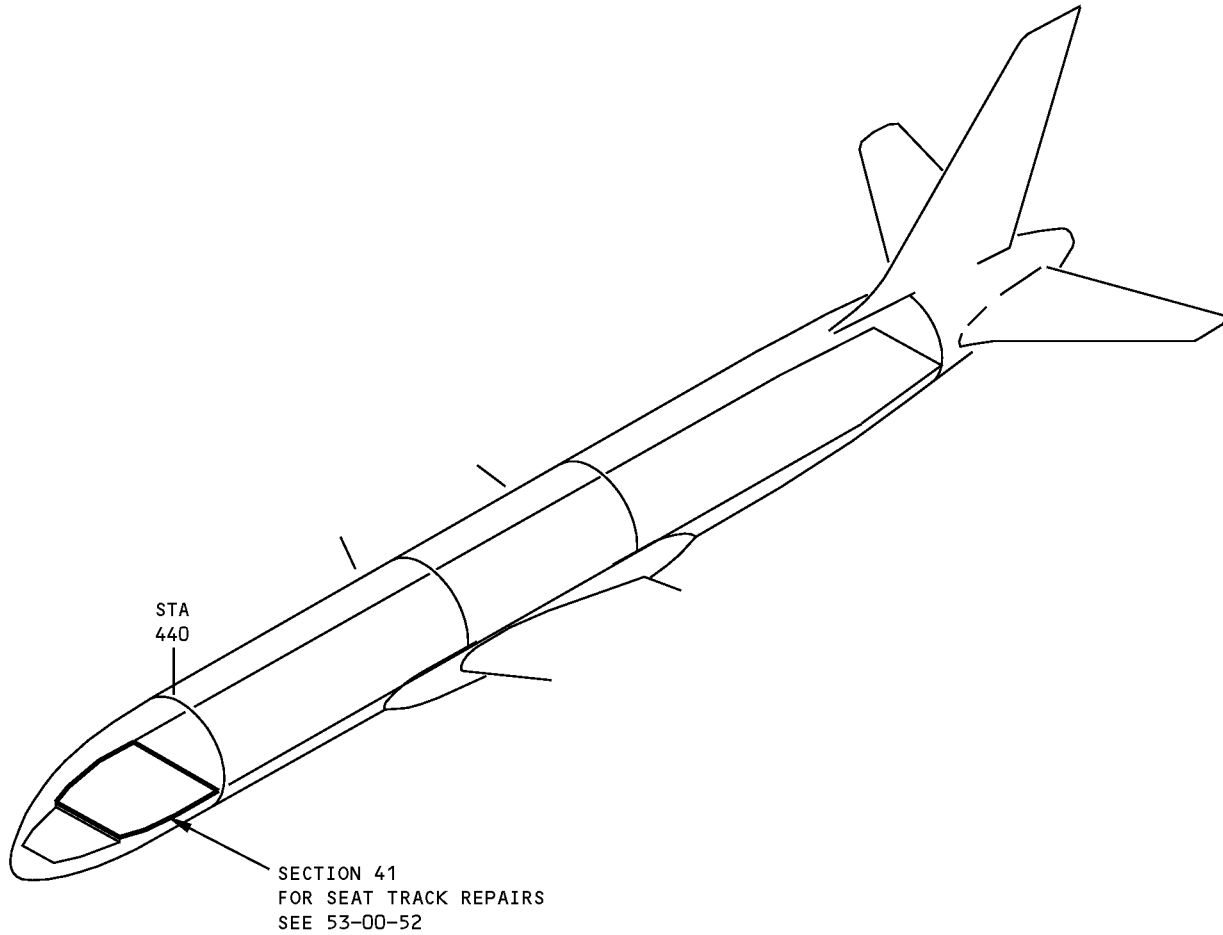
ALLOWABLE DAMAGE GENERAL
53-10-52 Page 101
Jan 20/2007



757-200
STRUCTURAL REPAIR MANUAL

REPAIR GENERAL - SECTION 41 - SEAT TRACKS

REF DWG
141N5130



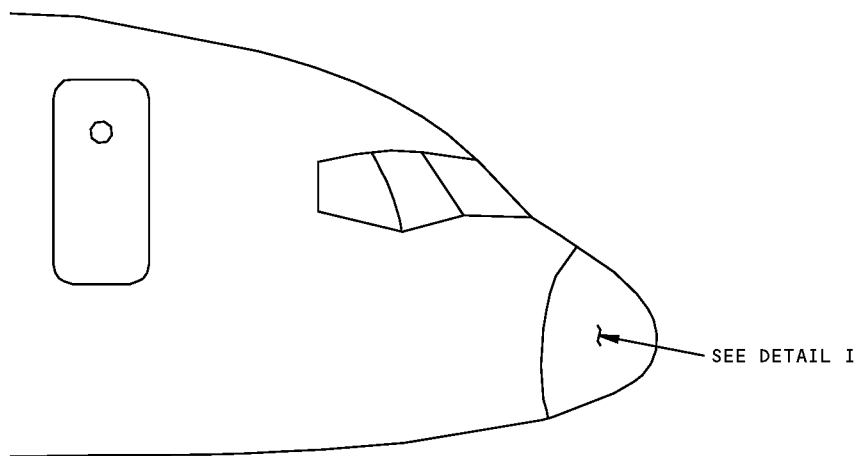
Section 41 Seat Track Repairs
Figure 201

D634N201

REPAIR GENERAL
Page 201
53-10-52
Jan 20/2005

**757-200
STRUCTURAL REPAIR MANUAL**

IDENTIFICATION 1 - NOSE RADOME



NOTES

- REFER TO FIGURE 201, 202, 203, AND 204 FOR NONMETALLIC HONEYCOMB CORE RADOME REPAIR.
- REFER TO SRM 53-11-72, REPAIR GENERAL FOR FLUTED CORE RADOME REPAIR.
- REFER TO SRM 53-10-72, REPAIR GENERAL FOR RADOME THICKNESS INFORMATION.

- B** SIDE PANELS CONSIST OF SEGMENTED CORE SECTIONS.
- C** 3 PLY SKIN RADOMES
- D** 4 PLY SKIN RADOMES

A HONEYCOMB AND FLUTED CORE RADOMES ARE IDENTIFIED BY PART NUMBER INSIDE THE RADOME SHELL:

284N1417-1 - NONMETALLIC HONEYCOMB CORE RADOME - 3 PLY SKIN

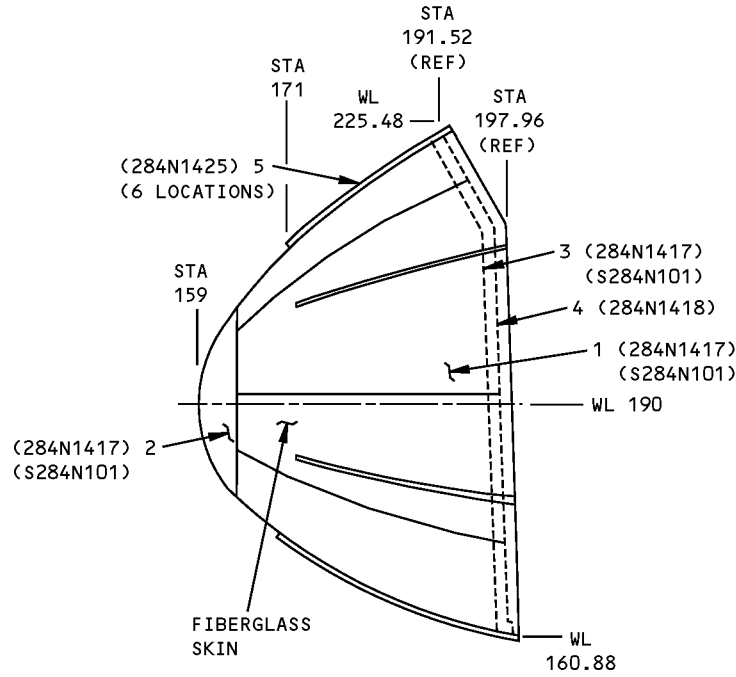
284N1417-11 - NONMETALLIC HONEYCOMB CORE RADOME - 4 PLY SKIN

S284N101-() - FLUTED CORE RADOME

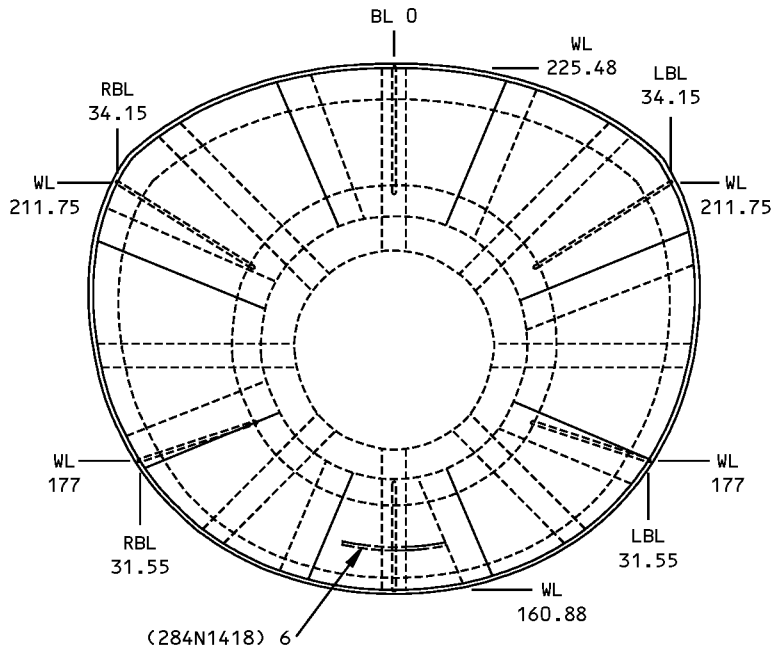
**Nose Radome Identification
Figure 1 (Sheet 1 of 3)**

**757-200
STRUCTURAL REPAIR MANUAL**

REFERENCE DRAWING
141N0070



SIDE VIEW



**VIEW LOOKING FORWARD
FIBERGLASS SKIN AND NOMEX HONEYCOMB OR FLUTED CORE RADOME
DETAIL I**

**Nose Radome Identification
Figure 1 (Sheet 2 of 3)**

IDENTIFICATION 1
Page 2
Jan 20/2005

53-10-72

D634N201



**757-200
STRUCTURAL REPAIR MANUAL**

ITEM	DESCRIPTION	GAGE	MATERIAL	EFFECTIVITY
1	SHELL ASSEMBLY	0.340 - 0.360	FIBERGLASS/HONEYCOMB SANDWICH AS GIVEN IN BAC5470 A	C
	SKIN, OUTER AND INNER	3 PLY	GLASS FABRIC REINFORCED PLASTIC AS GIVEN IN BMS 8-79, CLASS III, TYPE 1581 OR 7781, GRADE 1, 250°F (121°C) CURE	
2	NOSE PIECE	0.302 - 0.308	FLUTED CORE B OR NONMETALLIC HONEYCOMB AS GIVEN IN BMS 8-124, CLASS I, TYPE I, GRADE 5.5 B	D
	SKIN, OUTER AND INNER	3 PLY	FIBERGLASS/HONEYCOMB SANDWICH AS GIVEN IN BAC5470 A	
3	EDGE BAND	0.302 - 0.308	GLASS FABRIC REINFORCED PLASTIC AS GIVEN IN BMS 8-79, CLASS III, TYPE 1581 OR 7781, GRADE 1, 250°F (121°C) CURE	D
	DIRECTOR ELEMENT	0.350 (REF)	FLEX-CORE. HRH - 10/F50-5.0	
4	GROUNDING RING	0.025	SOLID LAMINATED PLIES GLASS FABRIC REINFORCED PLASTIC AS GIVEN IN BMS 8-79, CLASS III, TYPE 1581 OR 7781, GRADE 1, 250°F (121°C) CURE	
5	DIVERTER STRIP		6061-T4 ALUMINIUM SHEET AS GIVEN IN QQ-A-250/11	
6	DIRECTOR ELEMENT		STOCK BAC1511-3787, 6061-T6511 AL ALLOY	
1	SHELL ASSEMBLY	0.304 - 0.322	0.5 INCH WIDE ALUMINUM FOIL PRESSURE SENSITIVE TAPE	D
	SKIN, OUTER AND INNER	4 PLY	FIBERGLASS/HONEYCOMB SANDWICH AS GIVEN IN BAC5317-2, GRADE A CLASS D. A	
2	NOSE PIECE	0.246 - 0.258	GLASS FABRIC REINFORCED PLASTIC AS GIVEN IN BMS 8-79, CLASS III OR CLASS IV, TYPE 7781, GRADE B, 250°F (121°C) CURE	D
	SKIN, OUTER AND INNER	4 PLY	NONMETALLIC HONEYCOMB AS GIVEN IN BMS 8-124, CLASS I, TYPE I, GRADE 5.5 B	
3	EDGE BAND	0.246 - 0.258	FIBERGLASS/HONEYCOMB SANDWICH AS GIVEN IN BAC5317-2, GRADE A CLASS D.	D
	DIRECTOR ELEMENT	0.350 (REF)	GLASS FABRIC REINFORCED PLASTIC AS GIVEN IN BMS 8-79, CLASS III OR CLASS IV, TYPE 7781, GRADE B, 250°F (121°C) CURE	
4	GROUNDING RING	0.025	FLEX-CORE. HRH - 10/F50-5.0	
5	DIVERTER STRIP		SOLID LAMINATED PLIES GLASS FABRIC REINFORCED PLASTIC AS GIVEN IN BMS 8-79, CLASS III OR CLASS IV, TYPE 7781 OR 1581, GRADE B, 250°F (121°C) CURE	
6	DIRECTOR ELEMENT		6061-T4 ALUMINIUM SHEET AS GIVEN IN QQ-A-250/11	
			STOCK BAC1511-3787, 6061-T6511 AL ALLOY	
			0.5 INCH WIDE ALUMINUM FOIL PRESSURE SENSITIVE TAPE	

LIST OF MATERIALS FOR DETAIL I

**Nose Radome Identification
Figure 1 (Sheet 3 of 3)**

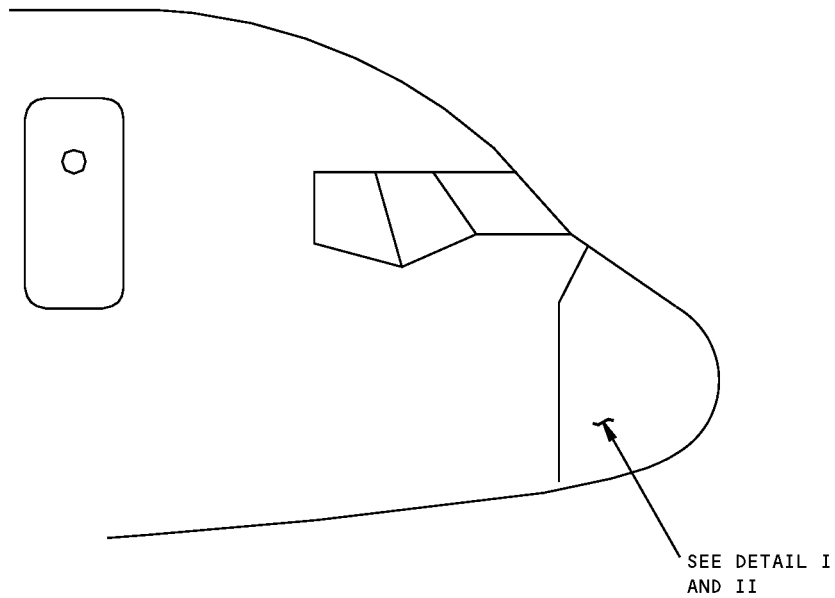
IDENTIFICATION 1
Page 3
Jan 20/2005

53-10-72

D634N201



757-200
STRUCTURAL REPAIR MANUAL
ALLOWABLE DAMAGE 1 - NOSE RADOME



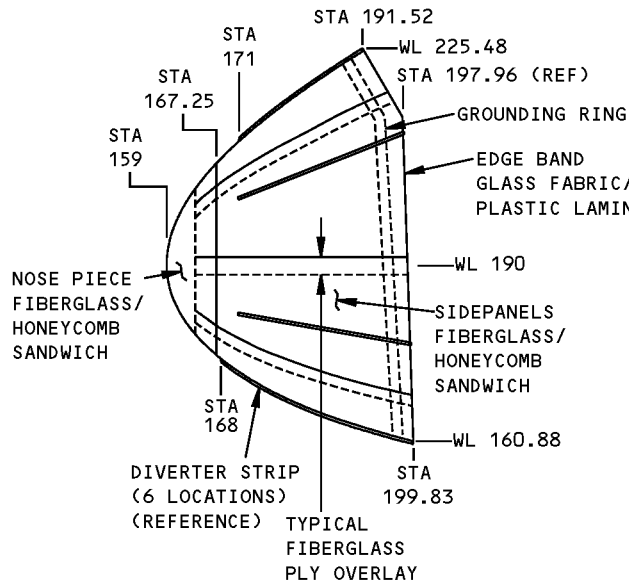
Nose Radome Allowable Damage
Figure 101 (Sheet 1 of 3)

D634N201

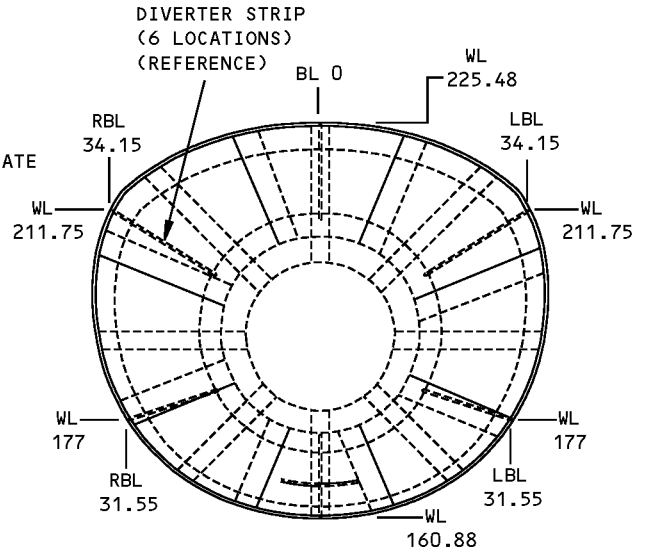
ALLOWABLE DAMAGE 1
Page 101
53-10-72 Jan 20/2005

**757-200
STRUCTURAL REPAIR MANUAL**

REFERENCE DRAWING
284N1418

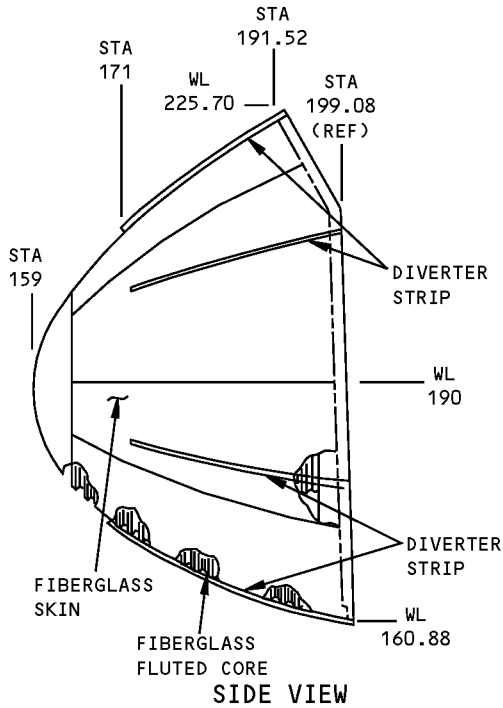


SIDE VIEW

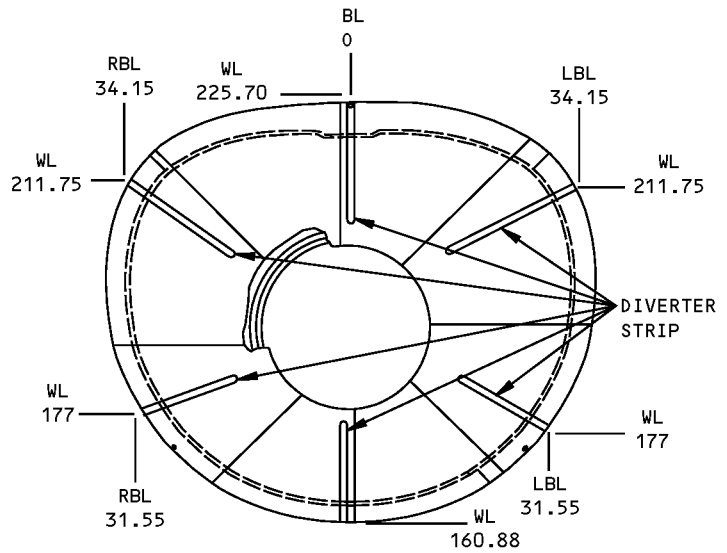


REAR VIEW

**FIBERGLASS SKIN WITH NOMEX HONEYCOMB CORE
RADOME
DETAIL I**



SIDE VIEW



REAR VIEW

**FIBERGLASS SKIN AND FLUTED CORE RADOME
DETAIL II**

**Nose Radome Allowable Damage
Figure 101 (Sheet 2 of 3)**

STRUCTURAL REPAIR MANUAL

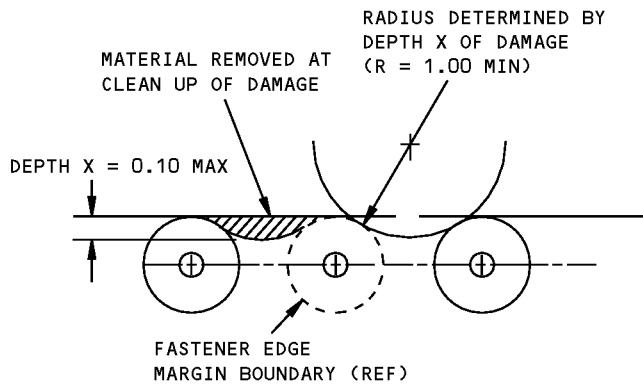
DESCRIPTION	CRACKS	NICKS, GOUGES AND CORROSION	DENTS	HOLES AND PUNCTURES
NOSE RADOME	CLEAN UP EDGE CRACKS PER DETAIL III. OTHER CRACKS ARE NOT PERMITTED	A B	A B	A B
GROUNDING RING	CLEAN UP EDGE CRACKS PER DETAIL III. OTHER CRACKS ARE NOT PERMITTED	A C	A C	A C

NOTES

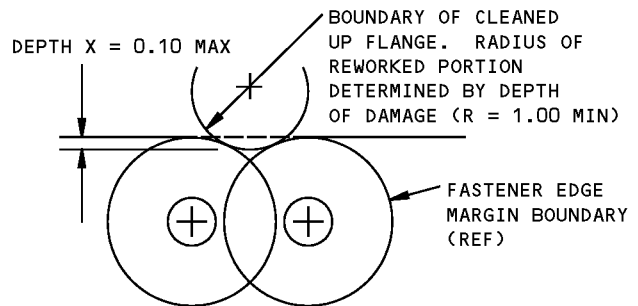
- A** AREAS OF DAMAGE, EACH NOT TO EXCEED 1 SQUARE INCH, DUE TO DETERIORATION, DELAMINATION, EROSION, DENTS, GOUGES, SCRATCHES AND PUNCTURES ARE PERMITTED IF:
- 1) THEY ARE NOT WITHIN 2 INCHES OF AN EDGE OR EDGE ATTACHMENT FASTENERS
 - 2) MINIMUM SPACING BETWEEN ADJACENT UNREPAIRED DAMAGE AREAS IS 10 INCHES.

- B** TEMPORARILY PROTECT UNREPAIRED DAMAGE FROM PENETRATION BY WATER OR OTHER FOREIGN MATTER BY SEALING WITH NONMETALIZED SCOTCH BRAND 850 OR 853, OR PERMACEL P95 POLYESTER TAPE (TAPE REPAIR IS SATISFACTORY IF GROUND OPERATION OF RADAR APPEARS SATISFACTORY). RECORD THE LOCATION OF THE DAMAGE AND REPAIR AT THE EARLIEST OPPORTUNITY

- C** APPLY THE FINISH TO ANY EXPOSED SURFACES. REFER TO SRM 51-20-01. THE MAXIMUM RESISTANCE BETWEEN THE AIRPLANE STRUCTURE AND THE GROUNDING RING IS 0.01 OHMS.



DAMAGE CLEAN UP OF EDGES WHERE FASTENER EDGE MARGINS DO NOT OVERLAP



DAMAGE CLEAN UP OF EDGES WHERE FASTENER EDGE MARGINS OVERLAP

DETAIL III

**Nose Radome Allowable Damage
Figure 101 (Sheet 3 of 3)**



757-200

STRUCTURAL REPAIR MANUAL

REPAIR GENERAL - NOSE RADOME

1. Applicability

- A. This repair section is applicable and approved for the repair of radomes as delivered or approved by Boeing for use on this model airplane. Repairs that are made from this repair section are not approved for radomes that have been modified, rebuilt or re-ringed using processes and materials that have not been approved by Boeing for use on this model airplane.

2. General

- A. This subject contains repair data for X-Band radomes with honeycomb core.
- B. Refer to 53-11-72, REPAIR GENERAL for repairs to radomes with fluted core.
- C. On the inside of the radome, keep a record of damage and the extent of the repairs that are made.
- D. Electrical Test Requirements

- (1) For the 3-ply radome, a test for electrical transmission efficiency is not necessary for all of the repairs given in this subject.

After you do a repair, the radome is classified as a Class B radome.

- (2) For the 4-ply radome, a test for electrical transmission efficiency is not necessary for all of the repairs given in this subject. After you do a repair, the radome is classified as a Class C radome. You can do a test to find if the radome has better electrical transmission efficiency.

- (3) The radome that is repaired and has primer, decorative paint, rain erosion protection applied and the lightning diverter strips installed must have the transmission efficiency requirements that follow:

NOTE: Thicknesses of paint which are more than 0.010 inch can decrease the necessary radome electrical transmission efficiency. A radome wall that has been repaired should be put back to its initial thickness. If this is not done, radome transmission efficiency will be decreased.

For repaired radomes on airplanes that have Predictive Wind Shear (PWS), and that are finished with CAAPCO erosion and p-static protection (Caapcoat B-274 as specified in BAC5880 and Caapcoat AS-P108), do a transmission efficiency test. The efficiency test must show the radome to be Class C or better.

- (a) The average transmission efficiency for a continuous scan of the antenna in the radome window area must not be less than:

- 1) 87% for Class B radomes.
- 2) 84% for Class C radomes.

NOTE: The radome window area is between ± 80 degrees azimuth and ± 20 degrees elevation.

- (b) The minimum transmission efficiency at a point in the radome window must not be less than:

- 1) 82% for Class B radomes.
- 2) 78% for Class C radomes.

- (4) If you needed to know the class of a repaired radome, measure the electrical transmission efficiency as given in Paragraph 2.4.7.1. of Document No. RTCA/DO-213 (Minimum Operational Performance Standards (MOPS) for Nose-Mounted Radomes). You can get a copy of this document from:

REPAIR GENERAL

Page 201

Jan 20/2006

53-10-72

D634N201



757-200 STRUCTURAL REPAIR MANUAL

RTCA, Incorporated
1828 L St, NW
Suite 805 Washington, D.C. 20036
U.S.A.
Telephone: 202-833-9339
Facsimile (FAX): 202-833-9434

- E. For moisture removal from X-Band radomes with honeycomb core, see Paragraph 5./REPAIR GENERAL.
- F. For small repairs, see Paragraph 16./REPAIR GENERAL.
- G. For wet layup repairs, see Paragraph 7./REPAIR GENERAL 6 and Figure 201/REPAIR GENERAL Figure 202/REPAIR GENERAL Figure 203/REPAIR GENERAL Figure 204/REPAIR GENERAL and Figure 205/REPAIR GENERAL.
- H. For repairs that use preimpregnated (prepreg) material, see Paragraph 8./REPAIR GENERAL and Figure 201/REPAIR GENERAL Figure 202/REPAIR GENERAL Figure 203/REPAIR GENERAL Figure 204/REPAIR GENERAL and Figure 205/REPAIR GENERAL.
- I. For aerodynamic smoothness requirements, refer to 51-10-01, GENERAL.
- J. For investigation and cleanup of damage, refer to 51-10-02, GENERAL.
- K. For a list of repair material sources, refer to 51-30-03, GENERAL.
- L. Refer to AMM 53-12-03 for repairs to the lightning strike diverter strips.
- M. Refer to AMM 53-12-05 for repairs to the glide slope director element.

3. References

Reference	Title
51-10-01, GENERAL	Aerodynamic Smoothness Requirements
51-10-02, GENERAL	Inspection and Removal of Damage
51-30-03, GENERAL	Nonmetallic Materials
51-70-05, GENERAL	Graphite/Aramid/Hybrid Reinforced Epoxy Laminates and Nonmetallic Honeycomb Sandwich Repairs - 250°F (121°C) Cure
51-70-06, GENERAL	Glass Fabric Reinforced Epoxy Laminates and Nonmetallic Honeycomb Sandwich Repairs - Room Temperature/150°F (66°C) Cure (Wet Layup)
53-10-72, IDENTIFICATION 1	Nose Radome
53-11-72, REPAIR GENERAL	HITCO Nose Radome
AMM 51-21-00	Aircraft Maintenance Manual
AMM 53-12-01	Aircraft Maintenance Manual
AMM 53-12-01/201	Aircraft Maintenance Manual
AMM 53-12-03	Aircraft Maintenance Manual
AMM 53-12-05	Aircraft Maintenance Manual
NDT Part 6, 53-10-01	Radome Thickness Measurement
SOPM 20-30-99	Solvents For Final Cleaning of Composites Before Structural Bonding (Series 99)

STRUCTURAL REPAIR MANUAL**4. Repair Limitations**

- A. For repair limitations, refer to Paragraph 15./REPAIR GENERAL, Paragraph 16./REPAIR GENERAL, and Figure 205/REPAIR GENERAL.

5. Find the Extent of the Damage

CAUTION: DO NOT USE CHEMICAL PAINT STRIPPERS TO REMOVE THE PAINT BEFORE YOU MAKE AN ANALYSIS OF THE DAMAGE TO THE RADOME. DAMAGE TO THE ADHESIVE RESIN SYSTEM WILL OCCUR.

- A. Examine the radome visually to find the extent of the damage and for the entry of oil, fuel, dirt or other unwanted material.
- B. Examine the radome for delaminations and moisture as given in 51-70-06, GENERAL.

NOTE: Delaminations can be found by instrumented nondestructive inspection (NDI) procedures. Refer to NDI, Part 4, 51-00-02. If NDI equipment is not available, use the tap test procedure. Hit the damaged area lightly with a solid metal disk. An area with a delamination will have a dull sound when you hit it lightly. An area with no delaminations will have a sharp sound.

- C. Examine the radome for damage to the lightning diverter strips and the glide slope director element (Figure 201/REPAIR GENERAL).

6. Moisture Removal from the Radome Honeycomb Structure

NOTE: There are two moisture removal methods. Make sure that delamination damage is not more than the limits given in par. 15.D.

- A. Remove moisture from honeycomb structure as given in par. B or refer to 51-70-06, GENERAL.

NOTE: Paragraph 6.B./REPAIR GENERAL gives the moisture removal procedures which adds a fiberglass repair ply over the damaged area. Paragraph 5.A./REPAIR GENERAL and Paragraph 6.A./REPAIR GENERAL give skin replacement procedures. The skin replacement procedure is recommended. The skin replacement procedure does not add a repair ply. Thus, it does not cause a decrease in the transmission efficiency.

- B. You can remove moisture from the honeycomb cells of the radome in an area with a maximum diameter of 20 inches.
- (1) Find the level of moisture contamination as given in AMM 53-12-01.
 - (2) Put masking tape around the area as given in Paragraph 7.B./REPAIR GENERAL (2 inches away all around the moisture contamination).
 - (3) Remove the Tedlar cover (moisture barrier) from the internal surface, 1 inch more all around than the damaged area. Use No. 240 or finer Scotch-Brite abrasive. Do not damage the fibers on the surface of the inner skin.
 - (4) On the inner surface, drill a 1/16-inch diameter hole into the approximate center of each cell that contains moisture. Do not damage the outer skin when you drill the holes.

CAUTION: DO NOT LET THE HEAT CAUSED BY DRILLING EXCEED 180°F (83°C) AT THE RADOME SURFACE OR DISTORTION MAY OCCUR.

- (5) Apply a heat blanket on the outer surface as given in 51-70-06, GENERAL.
- (6) The use of vacuum over the 1/16-inch diameter holes will increase the speed of the removal of moisture. Refer to 51-70-06, GENERAL.
- (7) When the area is dry, clean it as given in Paragraph 7.C./REPAIR GENERAL.

STRUCTURAL REPAIR MANUAL

- (8) Put down one layer of fiberglass fabric and resin as given in Paragraph 5./REPAIR GENERAL, or one prepreg ply as given in Paragraph 6./REPAIR GENERAL. Make the ply a sufficient size to go over the damaged area plus 1 inch more all around. This repair patch can be a maximum diameter of 22 inches.
- (9) Apply a source of pressure to the layup as given in Paragraph 13./REPAIR GENERAL.
- (10) Cure the fiberglass fabric and resin as given in Paragraph 14./REPAIR GENERAL. Cure the prepreg as given in Paragraph 14./REPAIR GENERAL.
- (11) Apply a finish to the repair area as given in Paragraph 15./REPAIR GENERAL.

7. Removal and Preparation of the Damaged Area**A. Damage removal.**

- (1) When damage has occurred to skins only, trim out the damaged laminations to a circular or oval shape. Take care not to damage the undamaged plies, core or surrounding material.

NOTE: Remove only damaged plies.

- (2) When the core is also damaged, remove the core by trimming to a circular or oval shape (Ref: 51-70-06, GENERAL for core removal procedure).

Take care to avoid cutting into an undamaged skin on the opposite side.

- (3) Areas contaminated by moisture that cannot be dried out by heating (temperature not to exceed 180°F [83°C]) must be removed with the other damage.

B. Preparation of damaged area (Figure 203/REPAIR GENERAL).

- (1) Determine the number of plies that have been cut. Mask off the area around the cutout allowing 1.00 inch for each ply replaced in a wet layup repair and 0.50 inch for each ply replaced in a prepreg repair. Add a 0.50-inch border.

NOTE: Where damage is through both skins the repair patch overlap of each skin must be offset to each other (Figure 203/REPAIR GENERAL).

CAUTION: SANDING OR ABRADING MUST NOT EXPOSE OR DAMAGE FIBERGLASS FILAMENTS IN THE UNDAMAGED SKIN. STRUCTURAL STRENGTH OF THE SKIN WILL BE REDUCED.

- (2) When damage has occurred to the internal skin, remove the Tedlar covering (moisture barrier) from an area that extends to 1.0 inch larger than the edge of the largest repair ply to be applied. Use No. 240 or finer Scotch-Brite abrasive.

CAUTION: DO NOT USE PAINT STRIPPERS TO REMOVE THE FINISH. DAMAGE TO THE FIBERGLASS RESIN SYSTEM WILL OCCUR.

- (3) Remove external finishes using No. 180 or finer sandpaper.
- (4) Protect exposed core with masking tape, metal plate, or equivalent.

WARNING: SANDING GIVES OFF A FINE DUST THAT MAY CAUSE SKIN IRRITATIONS. BREATHING OF AN EXCESSIVE AMOUNT OF THIS DUST MAY BE INJURIOUS. OBSERVE PRECAUTIONS FOR SKIN AND RESPIRATION PROTECTION.



757-200

STRUCTURAL REPAIR MANUAL

(WARNING PRECEDES)

EXPLOSIONPROOF EQUIPMENT MUST BE USED WHERE THE POSSIBILITY OF VAPOR IGNITION EXISTS. PERSONNEL INJURY MAY OCCUR.

- (5) Put a uniform taper around the repair with No. 180 sandpaper. Make the taper 1.00 inch for each ply of the laminate in a wet layup, and 0.50 inch for each ply of the laminate in a prepreg layup.

NOTE: For sanding, use a flexible disk sander, a belt sander, a rotating pad sander, or sand by hand.

- (6) When damage has occurred to the skins only, remove the damaged area of the skin only, and lightly sand the core where possible without reducing the core thickness.

CAUTION: BACK UP THE UNDAMAGED SKIN DURING SANDING TO AVOID DELAMINATION.

SANDING MUST NOT EXPOSE OR DAMAGE FIBERGLASS FILAMENTS IN THE UNDAMAGED SKIN. STRUCTURAL STRENGTH OF THE SKIN WILL BE REDUCED.

- (7) Where the core is damaged, but the opposite skin is undamaged, remove only the damaged core segment and sand the core bonding surface using No. 180 or finer sandpaper to remove resin fillets for the replacement core to seat properly.

C. Cleaning of the repair area.

WARNING: EXPLOSIONPROOF EQUIPMENT MUST BE USED WHERE THE POSSIBILITY OF VAPOR IGNITION EXISTS. PERSONNEL INJURY MAY OCCUR.

- (1) Remove all sanding dust by applying oil-free compressed air and a vacuum cleaner.

WARNING: WHEN USING SOLVENTS AVOID BREATHING VAPORS. USE MECHANICAL VENTILATION OR RESPIRATORY PROTECTION WHEN WORKING IN A CONFINED SPACE OR AREA. AVOID CONTACT WITH SKIN, EYES AND CLOTHING. WEAR APPROVED GLOVES AND PROTECTIVE CLOTHING. WEAR EYE PROTECTION. KEEP AWAY FROM SOURCES OF HEAT, FIRE OR SPARKS.

BREATHING VAPORS OR ALLOWING SOLVENT TO CONTACT SKIN OR EYES IS HAZARDOUS. HEAT, FIRE OR SPARKS CAN CAUSE AN EXPLOSION.

CAUTION: DO NOT IMMERSE PARTS IN SOLVENTS OR ALLOW STANDING SOLVENT ON PARTS. DAMAGE TO PARTS WILL OCCUR.

- (2) Wipe surfaces with a clean cloth moistened with solvent, Series 99 (AMM/SOPM 20-30-99). Allow solvent to evaporate before proceeding with the repair.

8. Repairs Using Wet Layup (Figures 203, 204, and 205)

NOTE: The repairs as given in the steps of this paragraph must put the radome back to its initial thickness as shown in Figure 201/REPAIR GENERAL. Failure to make the radome that is repaired the same thickness as the initial thickness will decrease the electrical performance of the radome. If you do not know the thickness of the radome after the repair, measure the thickness as given in NDT Part 6, 53-10-01 (Radome Thickness Measurements).

REPAIR GENERAL

Page 205

Sep 20/2007

53-10-72

D634N201

STRUCTURAL REPAIR MANUAL

CAUTION: DO NOT USE CHEMICAL PAINT STRIPPERS TO REMOVE THE PAINT BEFORE YOU MAKE AN ANALYSIS OF DAMAGE TO THE RADOME. DAMAGE TO THE ADHESIVE RESIN SYSTEM WILL OCCUR.

- A. Repair of the Skin Laminate (Figure 204/REPAIR GENERAL, Layups B and C).
- (1) Find the level of damage as given in Paragraph 5./REPAIR GENERAL
 - (2) Remove the damaged plies and prepare the area for repair as given in Paragraph 4./REPAIR GENERAL.
 - (3) Prepare the repair plies as given in Paragraph 7.A./REPAIR GENERAL
 - (4) Apply repair plies according to Paragraph 7.B./REPAIR GENERAL.
 - (5) Apply pressure according to Paragraph 13.A./REPAIR GENERAL.
 - (6) Cure the repair according to Paragraph 14./REPAIR GENERAL.
 - (7) Refinish the repair according to Paragraph 15./REPAIR GENERAL.

- B. Repair of damage to one skin and honeycomb core using replacement core (Figure 204/REPAIR GENERAL, Layups D and E).

NOTE: You have the option to cure the core plug installation before adding the repair plies.

- (1) Determine extent of damage according to Paragraph 5./REPAIR GENERAL.
 - (2) Remove damaged skin and core and prepare area according to Paragraph 4./REPAIR GENERAL.
 - (3) Fabricate, clean and install honeycomb replacement core according to Paragraph 12./REPAIR GENERAL.
 - (4) Optional, cure the core plug installation.
 - (a) Apply pressure according to Paragraph 13.A./REPAIR GENERAL.
 - (b) Cure according to Paragraph 14./REPAIR GENERAL.
 - (5) Prepare and apply repair plies according to Paragraph 7./REPAIR GENERAL.
 - (6) Apply pressure according to Paragraph 13.A./REPAIR GENERAL.
 - (7) Cure the repair according to Paragraph 14./REPAIR GENERAL.
 - (8) Refinish the repair according to Paragraph 15./REPAIR GENERAL.
- C. Repair of damage that extends through internal and external skins that includes honeycomb core replacement (Figure 204/REPAIR GENERAL, Layups F and G).
- (1) Determine extent of damage according to Paragraph 5./REPAIR GENERAL.
 - (2) Remove damaged skins and core according to Paragraph 5./REPAIR GENERAL.
 - (3) Make a plaster backup mold as follows:
 - (a) If the external skin is to be repaired first, fill the hole with a wooden plug or equivalent to provide an inner surface flush with the honeycomb core.

NOTE: If it is advantageous to repair the internal skin first, the backup mold may be formed on the external skin surface and the procedures reversed accordingly. Where necessary the backup mold may be made from a comparable area on another radome.

- (b) Cover the area with a parting film on the internal skin.
- (c) Dam the area to give a mold thickness of at least 1.0 inch thick.
- (d) Pour a water plaster mixture into the dam.

STRUCTURAL REPAIR MANUAL

- (e) When the plaster has hardened, remove it from the radome and dry it in an air circulating oven at 120°F (49°C) for approx 24 hours.
- (4) Remove the plug, the mold and the parting film from the internal skin.
- (5) Taper sand and clean the external skin according to Paragraph 7.B./REPAIR GENERAL and Paragraph 7.C./REPAIR GENERAL.
- (6) Cover the area with a clean parting film on the internal skin and secure the backup mold in position by means of clamps, props or lashing.
- (7) Fabricate, clean and install honeycomb replacement core according to Paragraph 12./REPAIR GENERAL.
- (8) Prepare and apply repair plies to the external skin according to Paragraph 7./REPAIR GENERAL.
- (9) Apply pressure according to Paragraph 13.A./REPAIR GENERAL.
- (10) Cure the repair according to Paragraph 14./REPAIR GENERAL.
- (11) Remove backup mold and parting film from internal skin.
- (12) Taper sand and clean the internal skin according to Paragraph 7.B./REPAIR GENERAL and Paragraph 7.C./REPAIR GENERAL.
- (13) Complete the repair according to Paragraph 8.A.(3)/REPAIR GENERAL thru Paragraph 8.A.(7)/REPAIR GENERAL.

9. Repairs Using Preimpregnated (Prepreg) Material (Figure 202, 204 (Sheet 1), and 205)

NOTE: The repair as given in the steps of this paragraph must put the radome back to its initial thickness as shown in Figure 201/REPAIR GENERAL. Failure to make the radome that is repaired the same thickness as the initial thickness will decrease the electrical performance of the radome. If you do not know the thickness of the radome after the repair, measure the thickness as given in NDT, Part 6, 53-10-01.

CAUTION: DO NOT USE CHEMICAL PAINT STRIPPERS TO REMOVE THE PAINT BEFORE YOU MAKE AN ANALYSIS OF DAMAGE TO THE RADOME. DAMAGE TO THE ADHESIVE RESIN SYSTEM WILL OCCUR.

A. Repair of Skin Laminate (Figure 202/REPAIR GENERAL).

- (1) Find the level of the damage as given in Paragraph 5./REPAIR GENERAL.
- (2) Remove the damaged plies and prepare the area for repair as given in Paragraph 4./REPAIR GENERAL.
- (3) Prepare the repair plies as given in Paragraph 8.A./REPAIR GENERAL.
- (4) Put down a piece of adhesive film on the skin that has been taper-sanded as given in Paragraph 7.B.(5)/REPAIR GENERAL. The adhesive film will bond the prepreg repair to the taper-sanded skin. Refer to Figure 202/REPAIR GENERAL and Figure 204/REPAIR GENERAL, Layup "A".

NOTE: The adhesive film can have an overlap of the honeycomb core area a maximum of 0.25 inch all around. Do not put the adhesive film fully over the honeycomb core area.

The adhesive film can have an overlap of the skin around the outer edge of the taper-sanded area a maximum of 0.25 inch. Refer to Paragraph 8.A.(2)/REPAIR GENERAL.

- (5) Install the repair plies as given in Paragraph 8.B./REPAIR GENERAL

STRUCTURAL REPAIR MANUAL

- (6) Apply pressure according to Paragraph 13.B./REPAIR GENERAL.
- (7) Cure the repair according to Paragraph 14./REPAIR GENERAL.
- (8) Refinish the repair according to Paragraph 15./REPAIR GENERAL.

10. Preparation and Application of Glass Fabric Repair Plies (Wet Layup) (Figures 203 and 204)**A. Prepare the overlay patch.**

- (1) Cut the repair plies from BMS 9-3 Type H, H-2, H-3, Class 7, 10, 11, 13 and 19 fiberglass cloth.
- (2) Cut two pieces of PVA parting film, or equivalent, approximately 3.0 inches larger all around than the glass fabric cloth. Use tape to hold one of the pieces to a smooth surface.
- (3) Prepare the resin using one of the methods that follow:
 - (a) Use Resin Mix 1, prepared according to 51-70-06.
 - (b) Use Resin Mix 2, prepared according to 51-70-17.
- (4) Spread the resin over parting film and place the glass fabric cloth over the resin.

NOTE: Weight of resin approximately equal to the weight of the dry glass fabric cloth is required to impregnate the cloth.

- (5) Cover the cloth on the parting film with the second piece of parting film.
- (6) Press the resin through the cloth by working over the parting film with a squeegee or roller, in order to impregnate the cloth and to remove entrapped air.
- (7) Cut the impregnated cloth to the required sizes for each individual ply of the patch. The parting film on both sides of the cloth decreases fraying of the edges while cutting the cloth. Direction of warp yarns in each individual ply must be in the same direction as warp yarns in the ply it replaces.

NOTE: Cut the first (smallest) ply of the patch 1.00 inch larger all around than the inner edge of the taper. Cut each ply that follows 1.00 inch larger all around than the ply before it (Figure 203/REPAIR GENERAL).

B. Apply overlay plies (Figure 203/REPAIR GENERAL).

NOTE: Where the damage has occurred at a lap joint in the original laminates, it is not necessary to make a comparable lap in the repair plies.

- (1) Remove the parting film from one side of the smallest ply of the patch and place the exposed face against the repair area, with the warp yarns in each individual ply in the same direction as the warp yarns of the ply it replaces. See 53-10-72, IDENTIFICATION 1 for Structure Identification.
- (2) Use a squeegee over the parting film that covers that patch to remove wrinkles and entrapped air. Do not apply excessive pressure.
Excessive pressure will produce a patch deficient in resin.
- (3) After removing parting film from the contact faces, place the next larger size ply of the impregnated patch over the ply on the repair area with a 1.00-inch overlap all around. See Figure 203/REPAIR GENERAL.
- (4) Place succeeding plies of the patch as described in steps (2) and (3) above.

11. Preparation and Application of Preimpregnated (Prepreg) Glass Fabric Repair Plies**A. Prepare the repair plies.**

STRUCTURAL REPAIR MANUAL

CAUTION: THE PREIMPREGNATED MATERIAL MUST REMAIN FREE OF CONTAMINATION DURING CUTTING AND HANDLING. WEAR CLEAN WHITE GLOVES WHEN HANDLING.

- (1) From fiberglass prepreg Type 1581 class III per BMS 8-79 material cut the required number of plies. Warp yarns in each individual ply must be in the same direction as the warp yarns in the ply it replaces. See 53-10-72, IDENTIFICATION 1 for Structure Identification.

NOTE: Cut the first (smallest) ply of the patch 0.50 inch larger all around than the inner edge of the taper. Cut each ply that follows 0.50 inch larger all around than the ply before it (Figure 202/REPAIR GENERAL). Type 7781 preimpregnated material may be substituted for the Type 1581 material.

- (2) See Figure 202/REPAIR GENERAL and Figure 204/REPAIR GENERAL, Layup A for the size of the film adhesive.

B. Apply the repair plies.

NOTE: Where the damage has occurred at a lap joint in the original laminates, it is not necessary to make a comparable lap in the repair plies.

- (1) Apply repair plies starting with the smallest. The direction of warp yarns in each individual ply must be the same direction as warp yarns in the ply it replaces. Each ply must overlap the next smaller ply with a 0.50-inch overlap all around. See Figure 202/REPAIR GENERAL.

NOTE: Remove the polyethylene separator after placing each ply.

12. Fabrication, Cleaning and Installation of Honeycomb Replacement Core Plug (For Wet Layup Only)

A. Fabricate core plug.

- (1) Cut a plug from honeycomb core material which is the same material as the initial core to fit the repair hole. Keep a maximum gap of 0.06 inch between the initial and repair core. See Figure 201/REPAIR GENERAL.

B. Clean core plug.

WARNING: WHEN USING SOLVENTS AVOID BREATHING VAPORS. USE MECHANICAL VENTILATION OR RESPIRATORY PROTECTION WHEN WORKING IN A CONFINED SPACE OR AREA. AVOID CONTACT WITH SKIN, EYES AND CLOTHING. WEAR APPROVED GLOVES AND PROTECTIVE CLOTHING. WEAR EYE PROTECTION. KEEP AWAY FROM SOURCES OF HEAT, FIRE OR SPARKS.

BREATHING VAPORS OR ALLOWING SOLVENT TO CONTACT SKIN OR EYES IS HAZARDOUS. HEAT, FIRE OR SPARKS CAN CAUSE AN EXPLOSION.

CAUTION: DO NOT USE CHLORINATED SOLVENTS. DAMAGE TO CORE MATERIAL WILL OCCUR.

- (1) Clean contaminated core by dipping it in solvent, Series 99 (AMM/SOPM 20-30-99) bath for 60 seconds.
- (2) Locally contaminated areas can be washed with solvent, Series 99 (AMM/SOPM 20-30-99).
- (3) The core must be completely free of solvents before installation.

C. Install the core plug.

- (1) Where the damage does not extend through both skin layers, prepare one ply for wet layup to fit the repair hole and put it on the inside of the skin that is not damaged. Refer to Paragraph 7.A./REPAIR GENERAL and Figure 204/REPAIR GENERAL, Layups D through G.

STRUCTURAL REPAIR MANUAL

(2) Apply potting compound to the core plug as follows:

- (a) Coat the edges of the original core and the core plug with BMS 5-28 potting compound. (You can use BMS 5-28, Types 15, 17, 19.)

NOTE: Mix potting compound according to the manufacturers instructions. Gel time is 60 to 90 minutes at 75 ± 5°F (24 ± 3°C).

- (b) Install the core plug with ribbon direction aligned with original core ribbon direction.

13. Application of Pressure

A. Application of pressure to repair made with wet layup.

- (1) Make a vacuum bag, evacuate the space under the bag and check for leaks. Refer to 51-70-05, GENERAL.

B. Application of pressure to repair made with preimpregnated material (BMS 8-79).

NOTE: Heat will reduce the pot life of the resin.

- (1) Make a vacuum bag, evacuate the space under the bag and check for leaks. Refer to 51-70-05, GENERAL.

14. Curing of Repair

NOTE: Heat can be applied with the use of an oven or a heat lamp. The rate of temperature increase should be gradual. When you use an oven, begin the cure in a cold oven. Refer to 51-70-06, GENERAL for cure times and temperature ranges. Remove trapped air bubbles as they arise during the cure.

CAUTION: THE APPLICATION OF HEAT IN EXCESS OF 180°F (83°C) WITHOUT THE APPLICATION OF PRESSURE DEVICES COULD RESULT IN FURTHER DELAMINATION OF THE SKIN-TO-CORE BOND. IT IS RECOMMENDED, WHEN YOU ACCELERATE THE CURE BY THE APPLICATION OF HEAT, TO VACUUM BAG ALL OF THE RADOME OR APPLY 3 TO 5 PSI PRESSURE TO THE REPAIR AREA WITH SHOT BAGS OR OTHER MECHANICAL METHODS.

A. Cure all repairs with a vacuum of 22 inches of mercury minimum.

B. Cure the repairs with the materials which follow:

- (1) For repairs with BMS 8-79 and BMS 5-129, cure at 240°F to 260°F (116°C to 127°C) for 90 minutes minimum. The rate of temperature increase is 8°F (4.8°C) per minute maximum.
- (2) For repairs with BMS 8-301, Class 1, cure at 190°F to 210°F (88°C to 99°C) for 220 minutes minimum. The rate of temperature increase is 1°F to 5°F (0.6°C to 4.0°C) per minute maximum.
- (3) For repairs with BMS 8-301, Class 2, use one of the three cure procedures which follow:
- (a) Cure at 140°F to 160°F (60°C to 71°C) for 180 minutes minimum. The rate of temperature increase is 1°F to 5°F (0.6°C to 4°C) per minute maximum.
- (b) If there is no potting compound in the repair that is not cured, cure at 65°F to 75°F (18°C to 24°C) for 5 days minimum.

NOTE: You can handle, drill or sand the repair area after 10 hours at 65°F to 75°F (18°C to 26°C).

- (c) If there is potting compound in the repair that is not cured, cure at 72°F to 82°F (22°C to 28°C) for 7 days minimum.

- (4) For cure of the core plug installation only, use one of the two cure procedures which follow:



757-200

STRUCTURAL REPAIR MANUAL

- (a) Cure at 120°F to 130°F (49°C to 54°C) for 240 minutes minimum. Allow the potting compound to get at room temperature before heat is applied.
- (b) Cure at 75°F to 85°F (24°C to 29°C) for 2 days minimum.

15. Refinish After Repair

CAUTION: DO NOT SAND INTO THE INITIAL STRUCTURE. FAILURE TO OBEY WILL DECREASE THE STRENGTH OF THE COMPONENT.

- A. Lightly sand the edges of the repair area and remove resin burrs with No. 180 or finer sandpaper. Remove any remaining mold release with No. 180 or finer sandpaper.
- B. Clean the repair area as given in Paragraph 7.C./REPAIR GENERAL and examine for defects.

NOTE: The repair area must not have pits, blisters, void areas, or excess resin deposits.

- C. Seal any fibers that are open to the air with a thin layer of Resin Mix 1 or 3, prepared and cured as given in 51-70-06, GENERAL.
- D. In areas where Tedlar (moisture barrier) on the inner surface of the radome has been removed, apply a thin layer of Resin Mix 3 prepared as given in 51-70-06, GENERAL. Remove excess resin before it gels. Cure the resin as given in 51-70-06, GENERAL.
- E. Measure the thickness of the radome before the finish is applied, as given in NDT Part 6, 53-10-01.
- F. Put a finish to the exterior surface of the radome as given in AMM 53-12-01.
- G. Measure the thickness of the radome again after the finish has been applied as given in NDT Part 6, 53-10-01.
- H. Make sure the thickness of the finish that was applied is not more than what is given in AMM 53-12-01/201.
 - (1) Subtract the thickness that was measured before the finish was applied from the thickness that was measured after the finish was applied.
- I. If the thickness of the finish is more than what is given in AMM 53-12-01/201, do one of the steps that follow:
 - (1) Remove the finish and do the steps in Paragraph 15.E./REPAIR GENERAL through Paragraph 15.H./REPAIR GENERAL again.
 - (2) Do a test for electrical transmission efficiency to see if it is satisfactory. Refer to Paragraph 2.D.(4)/REPAIR GENERAL. If it is not satisfactory, remove the finish and do the steps in Paragraph 15.E./REPAIR GENERAL through Paragraph 15.H./REPAIR GENERAL again.
- J. If the glideslope director element (aluminum foil pressure-sensitive tape) has been removed or damaged, install it as given in AMM 53-12-05.

16. Repair of the Damage Caused by Electrical Discharge

CAUTION: DO NOT USE CHEMICAL PAINT STRIPPERS TO REMOVE PAINT BEFORE YOU FIND THE RANGE OF THE DAMAGE. CHEMICAL PAINT STRIPPERS WILL CAUSE DAMAGE TO THE RESIN SYSTEM.

- A. Clean the inner and outer surfaces. The radome must not have any moisture or dirt. Clean as given in AMM 51-21-00. Refer to Paragraph 6./REPAIR GENERAL for moisture removal procedures if necessary.
- B. Find the damage on the inner skin surface. Remove the exterior finish from the outer skin directly opposite from the damage sufficient to show all of the damage. Refer to Paragraph 7.B.(3)/REPAIR GENERAL.

REPAIR GENERAL

Page 211

Sep 20/2007

53-10-72

D634N201

STRUCTURAL REPAIR MANUAL

C. The performance of a leakage test with positive air pressure may help to locate outer skin defects which are not readily apparent.

- (1) Coat the outer skin defect area with an uncatalyzed resin film.
- (2) By using a flexible type funnel which encompasses the inner skin defect, apply a positive air pressure not to exceed 3 psi to this area.
- (3) The bubbling in the resin film will pinpoint the outer skin defect.

NOTE: Maximum repairable size of a single instance of damage caused by electrical discharge is 1 square inch, including punctures in both the inner and outer skins and the delaminated area. Minimum allowable spacing between adjacent repairs is 3 inches, edge to edge. For damage exceeding these limits see Paragraph 5.C./REPAIR GENERAL (wet layup) or 7.A. (prepreg).

D. Drill a 0.06-inch dia hole in the center of the defect, then insert a hypodermic needle through the skin and fill the core cell with Resin Mix 1, prepared according to 51-70-06, GENERAL.

E. Insert the hypodermic needle between the delaminated plies of the skin and inject with Resin Mix 1.

F. Coat the defects with a thin film of Resin Mix 1 and cover with PVA or other parting film.

G. When the resin has gelled, remove the parting film.

H. Refinish the repair according to Paragraph 15./REPAIR GENERAL.

17. Small Repairs

NOTE: The small repairs described in this paragraph will not require electrical testing provided the thickness limits shown in Figure 201/REPAIR GENERAL are not exceeded.

CAUTION: DO NOT USE CHEMICAL PAINT STRIPPERS TO REMOVE PAINT BEFORE YOU FIND THE RANGE OF THE DAMAGE. CHEMICAL PAINT STRIPPERS WILL CAUSE DAMAGE TO THE RESIN SYSTEM.

A. Surface scratches not penetrating glass fabric.

- (1) Remove scratches by sanding with No. 180 or finer sandpaper.
- (2) Clean the area according to Paragraph 7.C./REPAIR GENERAL.
- (3) Apply a layer of Resin Mix 1 or 3, prepared as given in 51-70-06, GENERAL.
- (4) Sweep area to fair in resin and remove any trapped air.
- (5) Cure the repair according to Paragraph 14./REPAIR GENERAL.
- (6) Refinish the repair according to Paragraph 15./REPAIR GENERAL.

B. Scratches penetrating one ply.

NOTE: This repair applies only where the damage does not exceed 2.0 inches long and 0.125 inch wide. More extensive damage requires the replacement of plies.

- (1) Sand out the scratch using No. 180 or finer sandpaper.
- (2) Clean the area according to Paragraph 7.C./REPAIR GENERAL.
- (3) Fill the scratch with Resin Mix 8 prepared as given in 51-70-06, GENERAL.
- (4) Allow to cure for a minimum of 24 hours at 70 ±5°F (21 ±3°C), or as given in 51-70-06, GENERAL.
- (5) Apply a layer of Resin Mix 1 or 3 to the repair area as given in 51-70-06, GENERAL.
- (6) Cure the repair according to Paragraph 14./REPAIR GENERAL.
- (7) Refinish the repair according to Paragraph 15./REPAIR GENERAL.



757-200

STRUCTURAL REPAIR MANUAL

C. Punctures less than 0.25-inch diameter.

- (1) Remove the damaged material from the vicinity of the puncture.
- (2) Clean the area according to Paragraph 7.C./REPAIR GENERAL.
- (3) Put the Resin Mix 8, prepared as given in 51-70-06, GENERAL, into the puncture.

NOTE: As an alternative use Presto Paste Resin consisting of 98 parts of Resin No. 49X2 and 2 parts of MEK Peroxide by weight.

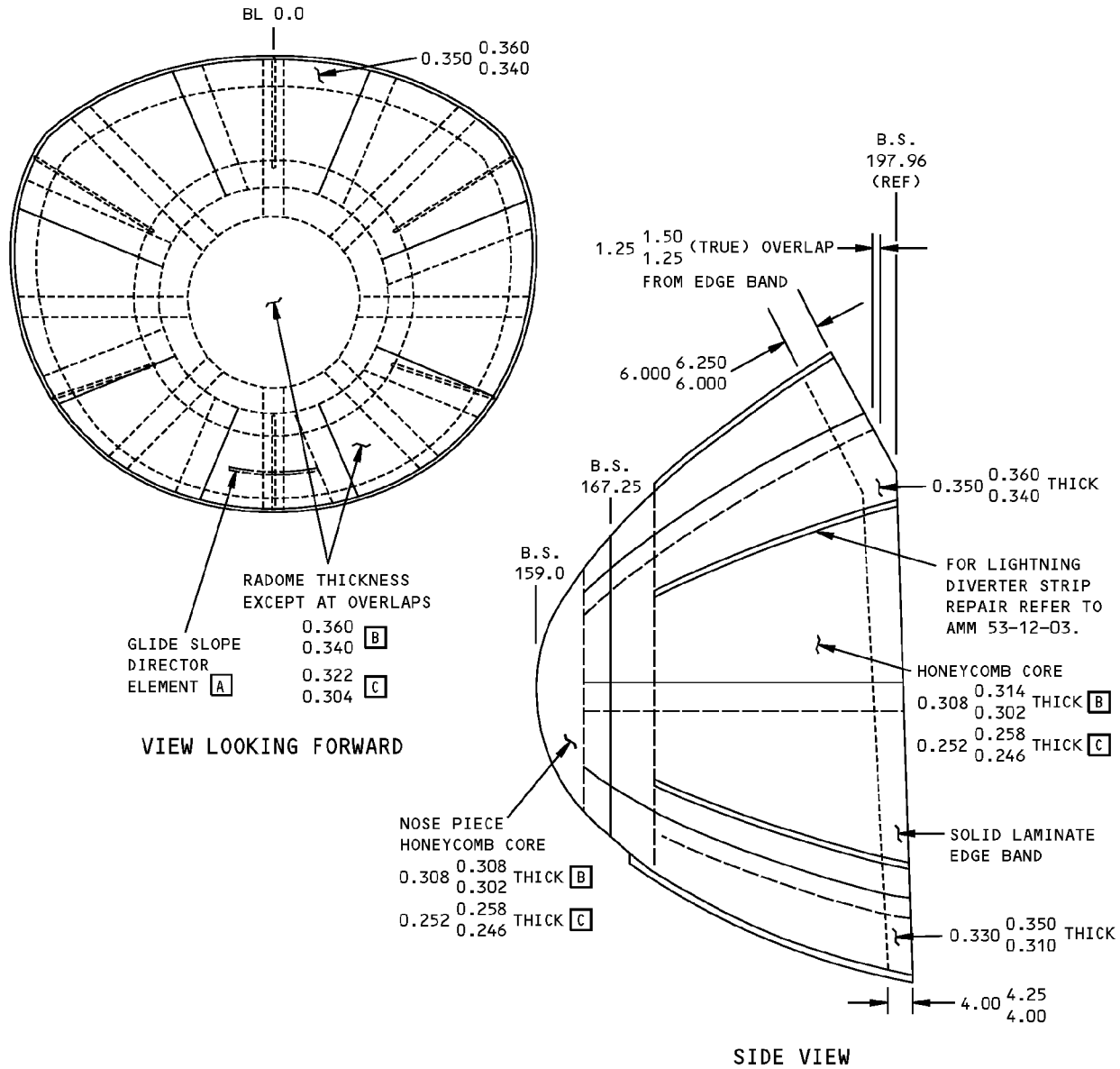
- (4) Allow resin to cure for 24 hours at 70°F (21°C), minimum.
- (5) Sand to fair with surrounding surface.
- (6) Refinish the repair according to Paragraph 15./REPAIR GENERAL.

D. Delamination of plies.

NOTE: This repair applies where delamination is confined to an area of 1.0 inch in diameter and where skin distortion is not excessive. Delamination which cannot be satisfactorily repaired by the following method, due to skin distortion or which exceed the size limitations, should be repaired according to Paragraph 5.A./REPAIR GENERAL or 7.A.

- (1) Determine extent of delamination by tapping radome skin with a small metallic object such as a short socket extension.
- (2) Inject Resin Mix 1, prepared as given in 51-70-06, GENERAL, between the delaminated plies. Use a hypodermic needle for injecting the resin as described in Paragraph 16.D./REPAIR GENERAL and Paragraph 16.E./REPAIR GENERAL.
- (3) Apply pressure according to Paragraph 13.A./REPAIR GENERAL.
- (4) Cure the repair according to Paragraph 14./REPAIR GENERAL.
- (5) Refinish the repair according to Paragraph 15./REPAIR GENERAL.

**757-200
STRUCTURAL REPAIR MANUAL**



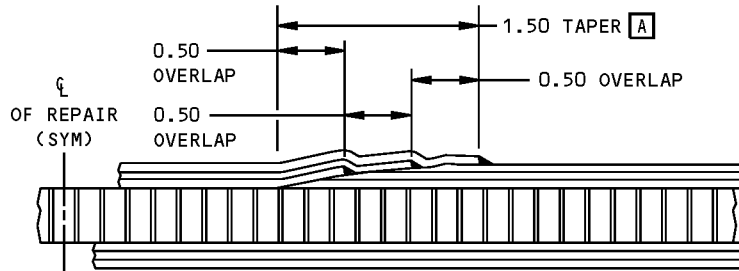
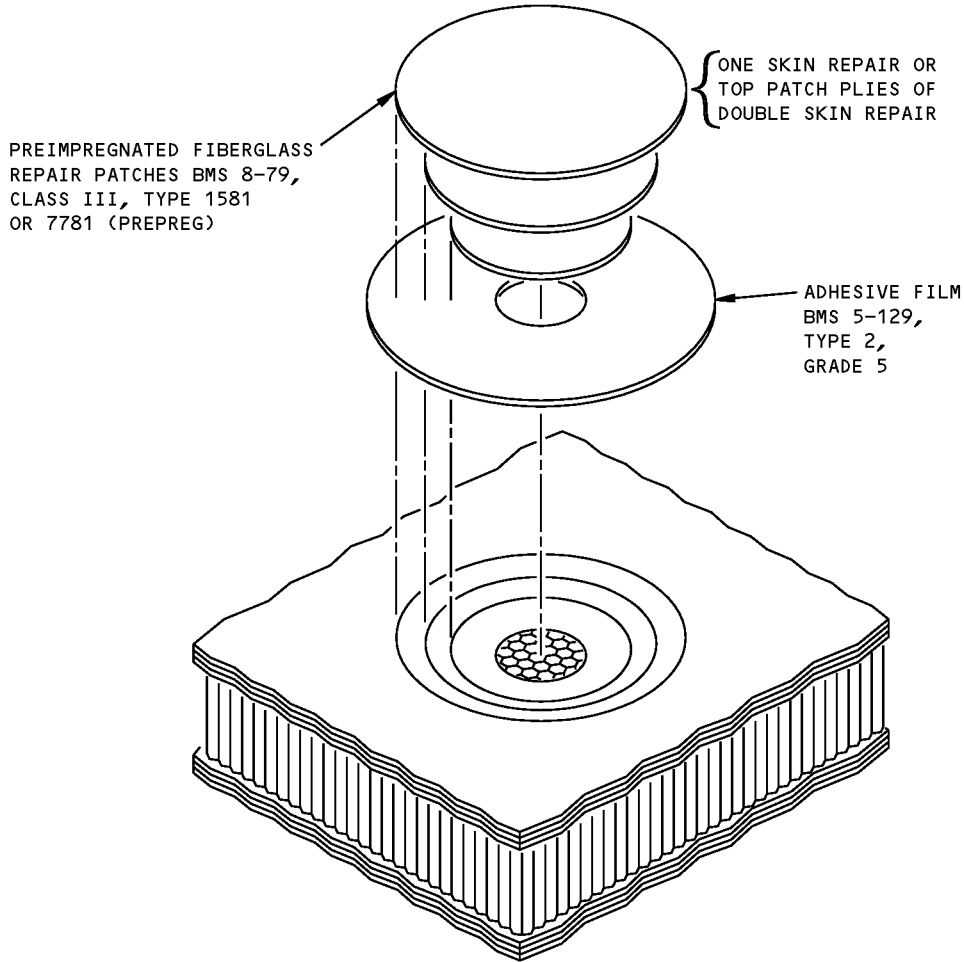
NOTES

- THICKNESSES ARE BASED ON CURED SANDWICH THICKNESS BEFORE APPLICATION OF FINISHES OR RAIN EROSION COATINGS.
- RADOME THICKNESS AFTER REPAIR MAY BE MEASURED USING THE EDDY CURRENT METHOD DESCRIBED IN THE NONDESTRUCTIVE TESTING MANUAL, D634N301, PART 6.

- [A] IF THE GLIDE SLOPE DIRECTOR ELEMENT (ALUMINUM FOIL PRESSURE SENSITIVE TAPE) HAS BEEN REMOVED OR DAMAGED, REINSTALL ACCORDING TO AMM 53-12-05.
- [B] 3 PLY SKIN
- [C] 4 PLY SKIN

**Thicknesses for Nose Radome
Figure 201**

**757-200
STRUCTURAL REPAIR MANUAL**



**SECTION THROUGH REPAIR
LAYUP "A"**

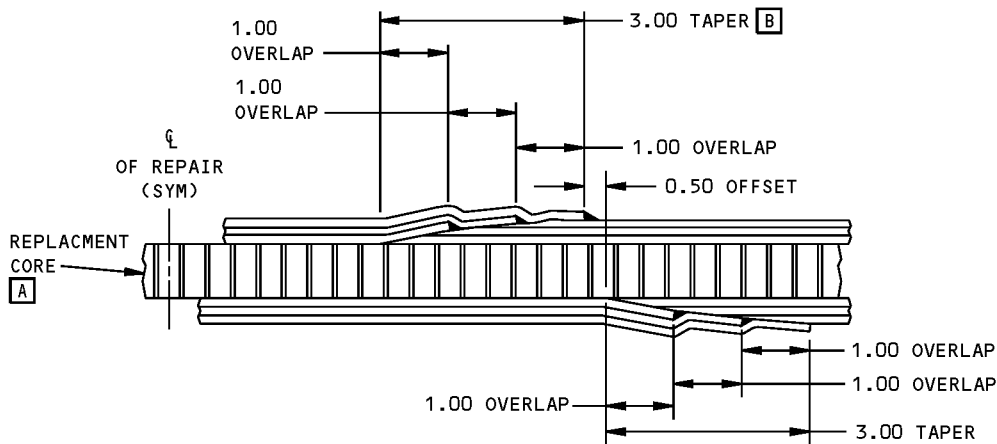
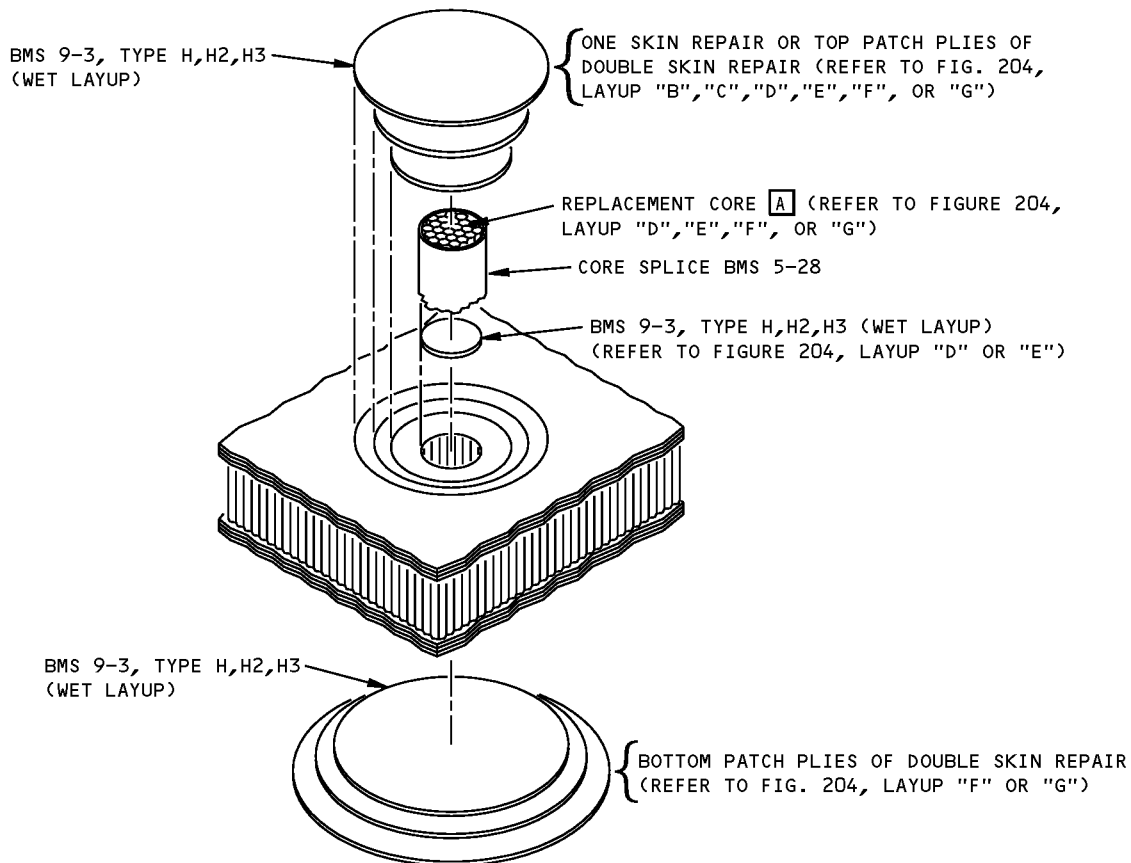
NOTES

- ALL DIMENSIONS SHOWN ARE IN INCHES
- 3 REPAIR PLYS FOR USE ON 3 PLY SKIN STRUCTURE ARE SHOWN. FOR 4 PLY SKIN STRUCTURE, USE 4 REPAIR PLYS WITH AN OVERLAP OF 0.50 FOR EACH.

[A] MAKE A 2.00 TAPER ON A 4 PLY SKIN STRUCTURE.

**Nose Radome Prepreg Repairs
Figure 202**

STRUCTURAL REPAIR MANUAL



NOTES

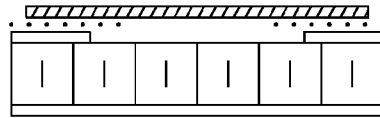
SECTION THROUGH REPAIR

- ALL DIMENSIONS SHOWN ARE IN INCHES.
- 3 REPAIR PLYS FOR USE ON 3 PLY SKIN STRUCTURE ARE SHOWN. FOR 4 PLY SKIN STRUCTURE, USE 4 REPAIR PLYS WITH AN OVERLAP OF 1.00 FOR EACH

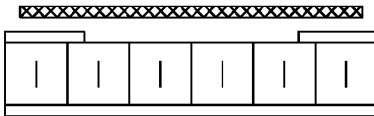
- [A] RIBBON DIRECTION MUST BE ALIGNED IN THE SAME DIRECTION AS THE INITIAL HONEYCOMB CORE.
- [B] MAKE A 4.00 TAPER ON A 4 PLY SKIN STRUCTURE.

Nose Radome Wet Layup Repairs
Figure 203

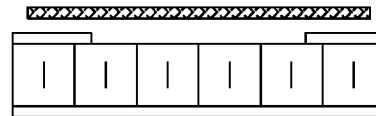
**757-200
STRUCTURAL REPAIR MANUAL**



LAYUP "A"
(PREPREG)



LAYUP "B"
(WET LAYUP)



LAYUP "C"
(WET LAYUP)

NOTES

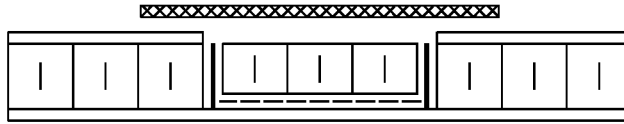
- ALL FACE SHEET REPAIRS MUST BE TAPER SANDED.
- AN OVERLAP OF 1.0 INCH FOR EACH PLY IS NECESSARY FOR ALL WET LAYUP REPAIRS. REFER TO FIG. 203.
- AN OVERLAP OF 0.50 INCH FOR EACH PLY IS NECESSARY FOR ALL PREPREG LAYUP REPAIRS, REFER TO FIG. 202.
- THE WARP DIRECTION OF ALL REPAIR PLIES MUST PARALLEL TO THE FORWARD/AFT DIRECTION OF THE RADOME.
- THE FILM ADHESIVE WHICH BONDS THE PREPREG REPAIR TO THE SALVAGED FACE SHEET CAN EXTEND A MAXIMUM OF 0.25 INCH INSIDE AND OUTSIDE THE TAPERED SANDED EDGE OF THE SALVAGED FACE SHEET.

LEGEND

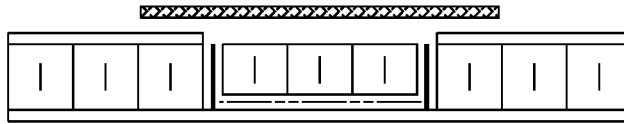
- BMS 5-129, TYPE 2, GRADE 5 ADHESIVE CURED AT 250°F (121°C)
- 1 LAYER OF BMS 9-3, TYPE H,H2, OR H3 IMPREGNATED WITH BMS 8-301, CLASS 2 RESIN CURED AT 150°F ±10°F (66°C ±6°C) OR CLASS 1 CURED AT 200°F (93°C)
- 1 LAYER OF BMS 9-3, TYPE H,H2, OR H3 IMPREGNATED WITH BMS 8-301, CLASS 2 RESIN CURED AT ROOM TEMPERATURE
- ===== SALVAGED BMS 8-79 FACE SHEET
- ////// PLIES OF BMS 8-79, TYPE H,H2, OR H3 CURED AT 250°F (121°C)
- XXXXXX PLIES OF BMS 9-3, STYLE 1581 OR STYLE 7781 IMPREGNATED WITH BMS 8-301, CLASS 2 RESIN CURED AT 150°F ±10°F (66°C ±6°C) OR CLASS 1 CURED AT 200°F (93°C)
- XXXXXX PLIES OF BMS 9-3, TYPE H,H2, OR H3 IMPREGNATED WITH BMS 8-301, CLASS 2 RESIN CURED AT ROOM TEMPERATURE
- ===== BMS 5-28 TYPES 15,17, OR 19
- ||| SAME AS INITIAL FIBERGLASS CORE

**Nose Radome Repair Layups
Figure 204 (Sheet 1 of 2)**

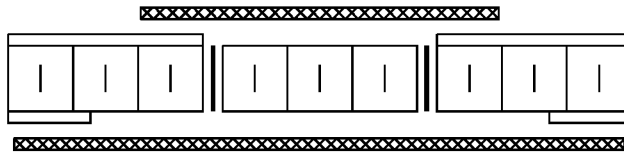
757-200
STRUCTURAL REPAIR MANUAL



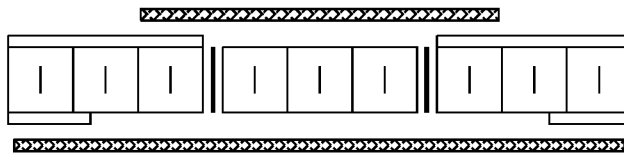
LAYUP "D"
(WET LAYUP)



LAYUP "E"
(WET LAYUP)



LAYUP "F"
(WET LAYUP)



LAYUP "G"
(WET LAYUP)

Nose Radome Repair Layups
Figure 204 (Sheet 2 of 2)

**757-200
STRUCTURAL REPAIR MANUAL**

REPAIR TYPE	LAYUP TYPE	REPAIR SIZE MAXIMUM DIAMETER (INCHES)	REPAIR CLASSIFICATION	
OUTER OR INNER FACE SHEET REPAIR ONLY	"A"	NO LIMIT	PERMANENT	A
	"B"	0-4 MAX	PERMANENT	A
		4-30 MAX 30-50 MAX	PERMANENT TEMPORARY	B C
"C"	0-15 MAX	TEMPORARY	C	
OUTER OR INNER FACE SHEET AND CORE REPAIR ONLY	"D"	0-4 MAX	PERMANENT	A
		4-25 MAX 25-40 MAX	PERMANENT TEMPORARY	B C
	"E"	0-15 MAX	TEMPORARY	C
OUTER AND INNER FACE SHEET AND CORE REPAIR ONLY	"F"	0-10 MAX	PERMANENT	B
		10-20 MAX	TEMPORARY	C
"G"	0-10 MAX	TEMPORARY	C	

**RADOME REPAIR REQUIREMENTS
TABLE I**

NOTES

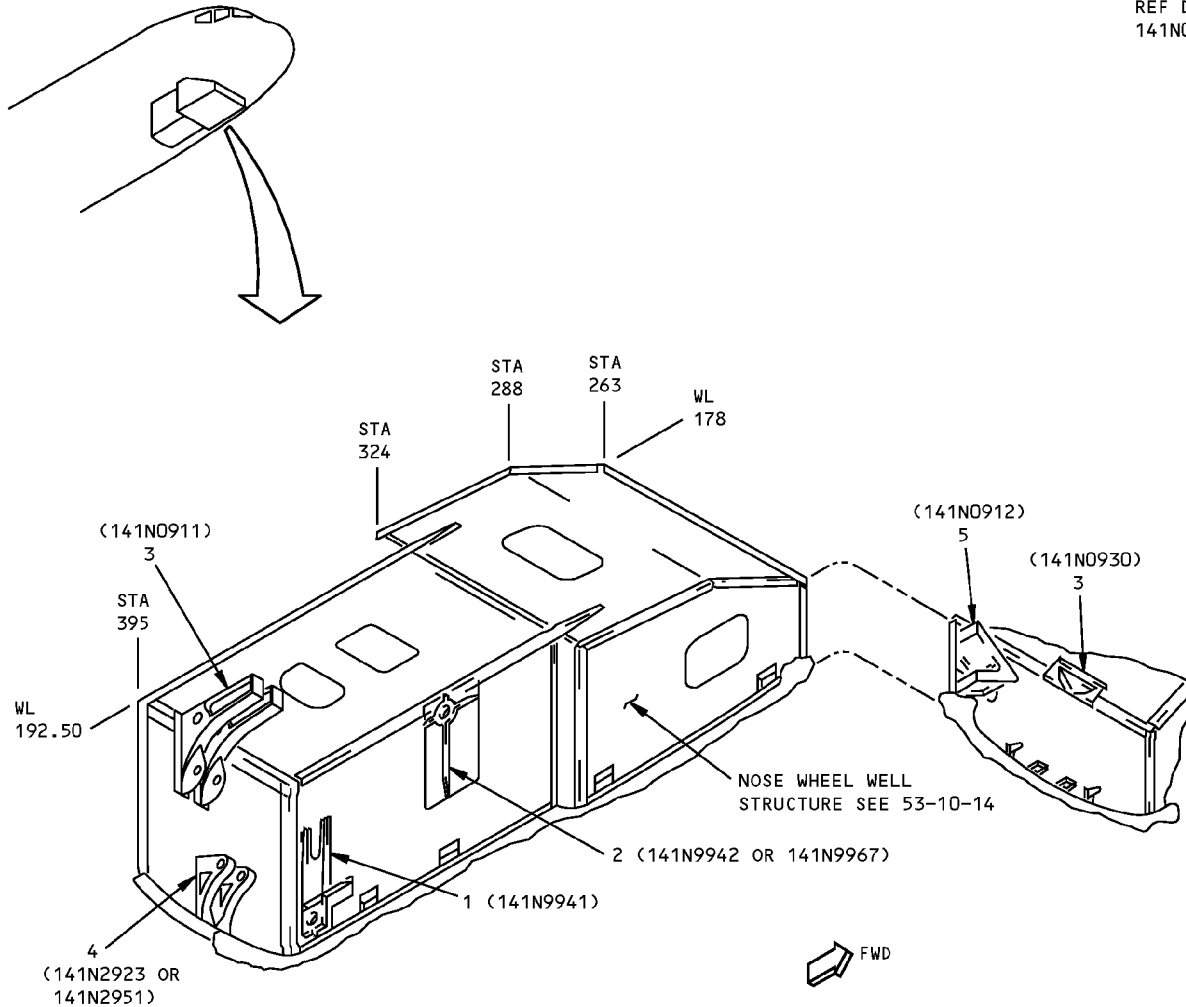
- TWO SMALL REPAIRS NEAR EACH OTHER CAN BE MADE INTO ONE LARGER REPAIR AS GIVEN IN TABLE I.
 - A REPAIR SHOWN AS A TEMPORARY REPAIR MUST HAVE A VISUAL AND TAP TEST INSPECTION OF THE REPAIR AREA AT EACH "2A" CHECK. REPLACE A TEMPORARY REPAIR WITH A PERMANENT REPAIR BY THE NEXT "C" CHECK.
 - THE MAXIMUM DIAMETER OF THE DAMAGE IS EQUAL TO THE MAXIMUM DIAMETER OF THE DAMAGED AREA AFTER CLEANUP OR THE MAXIMUM CUT OUT DIAMETER BEFORE TAPER SANDING. THE DIAMETER OF THE REPAIR IS MEASURED ALONG THE CONTOUR OF THE REPAIR.
 - KEEP A MINIMUM DISTANCE OF 3.0 INCHES (EDGE-TO-EDGE OF THE LARGEST REPAIR PLIES) FROM ANY OTHER REPAIR PLIES (ON EITHER SIDE OF THE PANEL).
 - INNER AND OUTER FACE SHEET REPAIRS WHICH ARE OPPOSITE EACH OTHER ARE NOT PERMITTED EXCEPT AS SHOWN IN LAYUPS "F" AND "G".
- A** MORE THAN ONE REPAIR IS PERMITTED.
- B** TWO OR MORE REPAIRS IN THIS CATEGORY ARE PERMITTED BUT ALL REPAIRS ARE THEN CLASSIFIED AS TEMPORARY.
- C** ONE REPAIR ONLY OF THIS SIZE IS PERMITTED.

**Nose Radome Repair Requirements
Figure 205**

**757-200
STRUCTURAL REPAIR MANUAL**

IDENTIFICATION 1 - NOSE LANDING GEAR ATTACHMENT FITTINGS

REF DWG
141N0901



ITEM	DESCRIPTION	GAGE	MATERIAL	EFFECTIVITY
1	TRUNNION FITTING		FORGED BLOCK 7075-T73	
2	SUPPORT FITTING		FORGING 7075-T73 OR FORGED BLOCK 7075-T7352	
3	ACTUATOR FITTING		FORGED BLOCK 7075-T73	
4	LOWER LINK FITTING		FORGING 7075-T73 OR FORGED BLOCK 7075-T7352	
5	SUPPORT FITTING		FORGED BLOCK 7075-T73	

LIST OF MATERIALS

**Nose Landing Gear Attachment Fitting Identification
Figure 1**

IDENTIFICATION 1
Page 1
Jan 20/2005

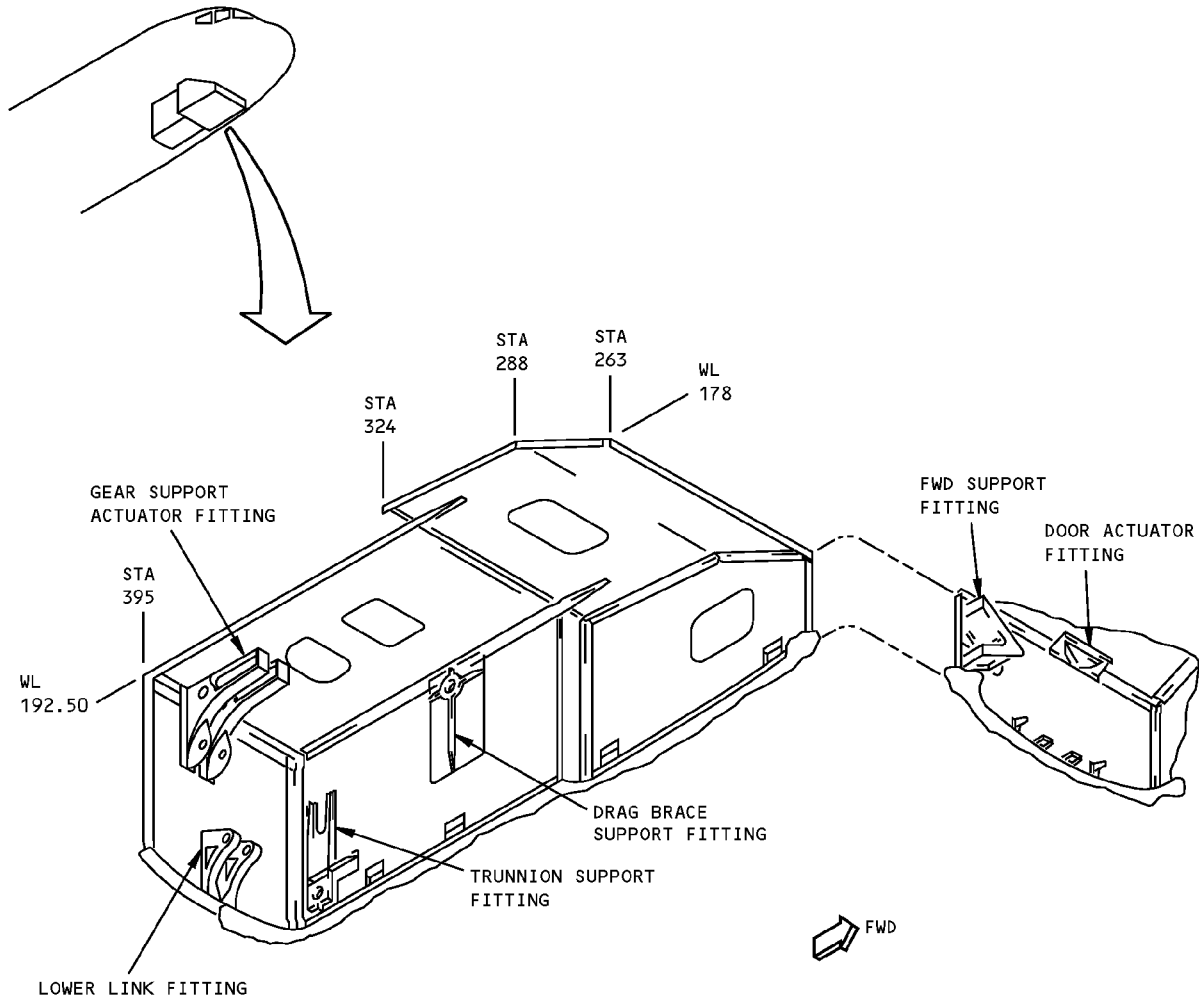
53-10-90

D634N201

**757-200
STRUCTURAL REPAIR MANUAL**

ALLOWABLE DAMAGE 1 - NOSE LANDING GEAR ATTACHMENT FITTINGS

REF DWG
141N0901



MATERIAL: ALUMINUM FORGED BLOCK

DESCRIPTION	CRACKS	NICKS, GOUGES AND CORROSION	DENTS	HOLES AND PUNCTURES
GEAR SUPPORT ACTUATOR FITTING	A	B	NOT ALLOWED	NOT ALLOWED
DOOR ACTUATOR FITTING	A	C	NOT ALLOWED	NOT ALLOWED
FWD SUPPORT FITTING	A	C	NOT ALLOWED	NOT ALLOWED
DRAG BRACE SUPPORT FITTING	A	D	NOT ALLOWED	NOT ALLOWED
TRUNNION SUPPORT FITTING	A	E	NOT ALLOWED	NOT ALLOWED
LOWER LINK FITTING	A	C	NOT ALLOWED	NOT ALLOWED

**Nose Landing Gear Attachment Fittings Allowable Damage
Figure 101 (Sheet 1 of 4)**

ALLOWABLE DAMAGE 1
Page 101
Jan 20/2005

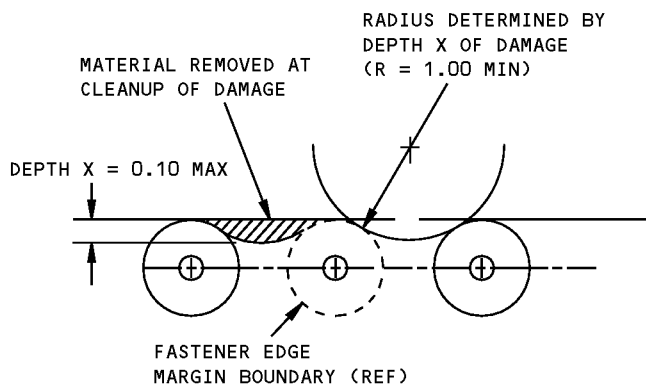
53-10-90

D634N201

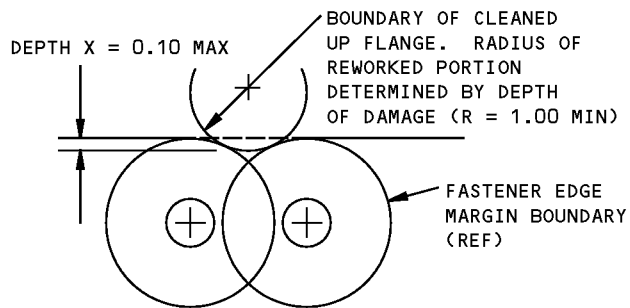
757-200
STRUCTURAL REPAIR MANUAL

NOTES

- SHOT PEEN ALL REWORKED AREAS PER 51-20-06
 - REFINISH REWORKED AREAS PER 51-20 OF THE MAINTENANCE MANUAL
- A** CLEAN UP EDGE CRACKS PER DETAILS I AND IV. OTHER CRACKS NOT ALLOWED
- B** CLEAN UP EDGE DAMAGE PER DETAILS I AND IV. FOR OTHER DAMAGE SEE DETAILS II AND V. FOR LUG DAMAGE SEE DETAIL III
- C** CLEAN UP EDGE DAMAGE PER DETAILS I AND IV. FOR OTHER DAMAGE SEE DETAIL II. FOR LUG DAMAGE SEE DETAIL III
- D** CLEAN UP EDGE DAMAGE PER DETAILS I AND IV. FOR OTHER DAMAGE SEE DETAILS II AND VI
- E** CLEAN UP EDGE DAMAGE PER DETAILS I AND IV. FOR OTHER DAMAGE SEE DETAILS II AND V



DAMAGE CLEANUP OF EDGES WITH FASTENERS WHERE EDGE MARGINS DO NOT OVERLAP

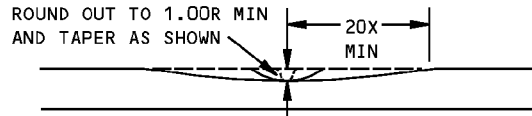
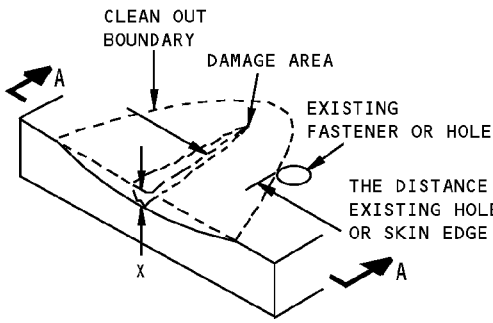


DAMAGE CLEANUP OF EDGES WITH FASTENERS WHERE EDGE MARGINS OVERLAP

DETAIL I

Nose Landing Gear Attachment Fittings Allowable Damage
Figure 101 (Sheet 2 of 4)

STRUCTURAL REPAIR MANUAL

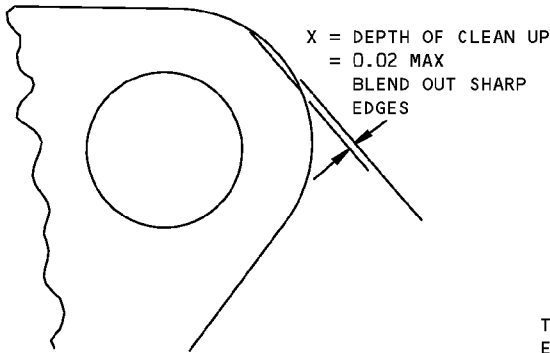


X = DEPTH OF CLEANUP
= 10% THICKNESS MAX

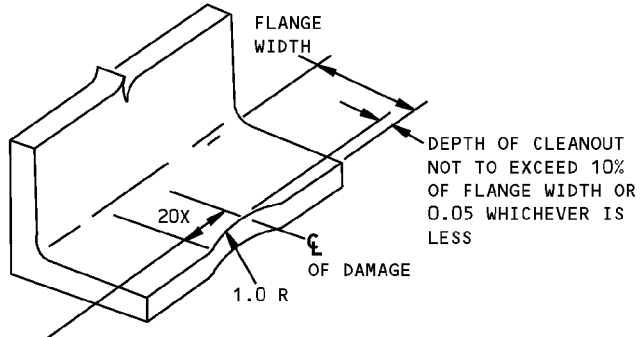
THE AREA REMOVED FOR CLEANUP
MUST NOT EXCEED 4% OF THE CROSS
SECTIONAL AREA

SECTION A-A

REMOVAL OF NICK, GOUGE AND SCRATCH DAMAGE ON A SURFACE
DETAIL II

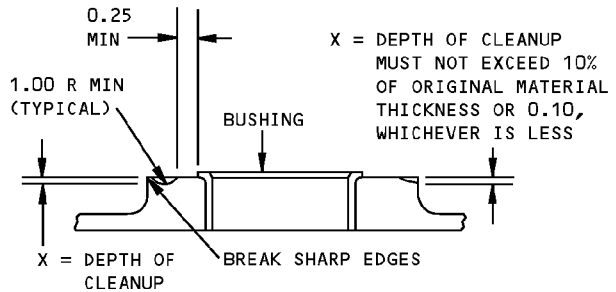
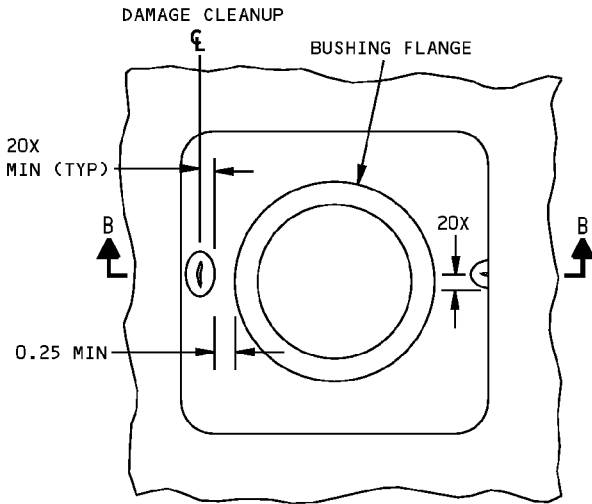


DAMAGE CLEANUP FOR EDGES OF LUG
DETAIL III



THE DISTANCE OF THE DAMAGE FROM AN
EXISTING HOLE, FASTENERS, OTHER DAMAGE
OR EDGE MUST NOT BE LESS THAN 20X

REMOVAL OF EDGE DAMAGE FROM
FREE FLANGE WITHOUT FASTENERS
DETAIL IV

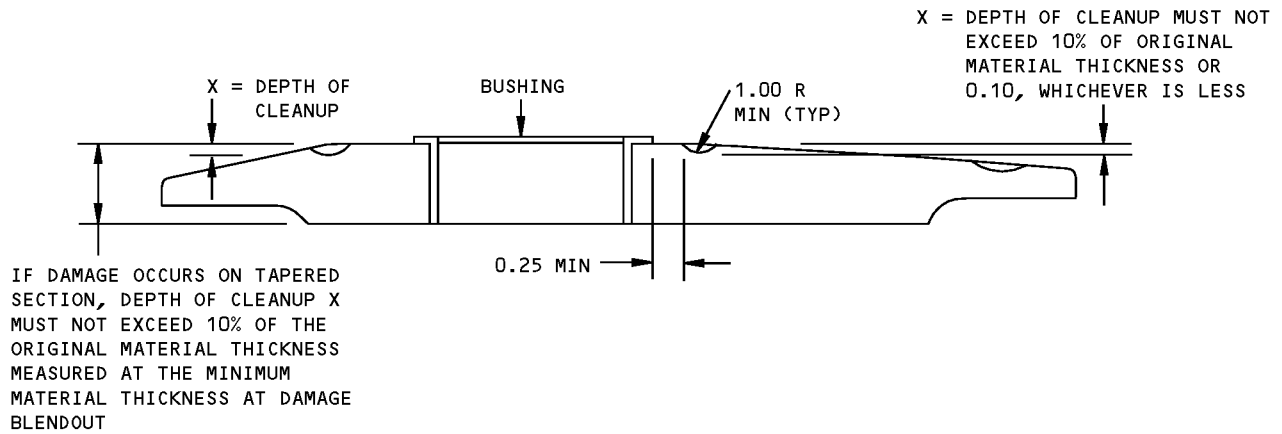
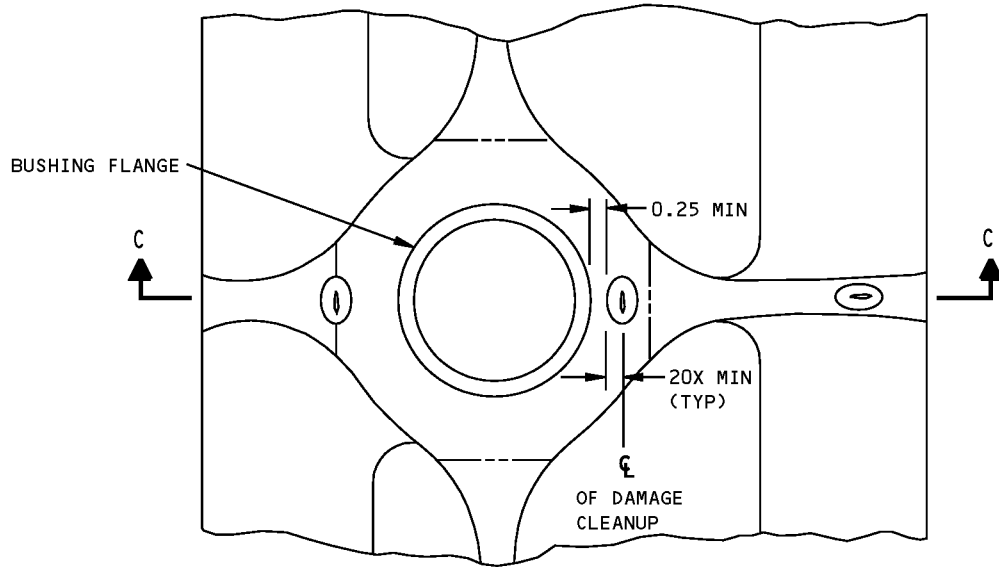


SECTION B-B

DETAIL V

**Nose Landing Gear Attachment Fittings Allowable Damage
Figure 101 (Sheet 3 of 4)**

**757-200
STRUCTURAL REPAIR MANUAL**



SECTION C-C

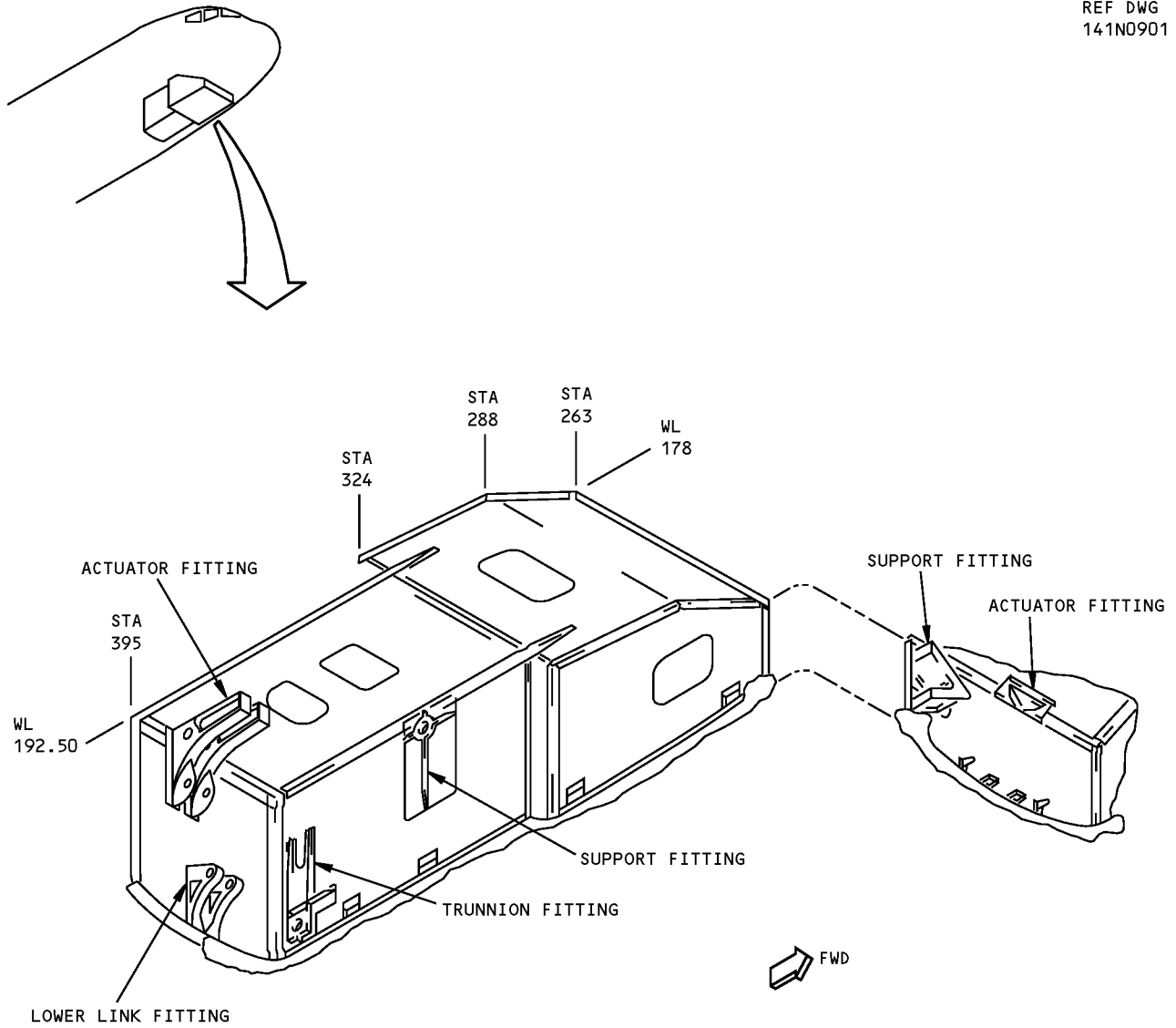
DETAIL VI

**Nose Landing Gear Attachment Fittings Allowable Damage
Figure 101 (Sheet 4 of 4)**

**757-200
STRUCTURAL REPAIR MANUAL**

REPAIR GENERAL - NOSE LANDING GEAR ATTACHMENT FITTINGS

REF DWG
141N0901



NOTES

- NO TYPICAL REPAIR TO FITTINGS APPLICABLE.
SPECIFIC REPAIRS TO FITTINGS WILL BE
PROVIDED BASED ON SERVICE EXPERIENCE

**Nose Landing Gear Attachment Fitting Repair
Figure 201**

D634N201

53-10-90

REPAIR GENERAL
Page 201
Jan 20/2005

757-200
STRUCTURAL REPAIR MANUAL

REPAIR GENERAL - HITCO NOSE RADOME

1. Scope

- A. This section establishes the material, processes, equipment, and their implementation necessary to effect structural repairs of fluted core sandwich components.
- B. A maximum of 15 percent of the surface of the fluted core area shall be considered repairable unless otherwise restricted by the engineering drawing or by an applicable construction document. Any damage of a magnitude greater than 15 percent shall be considered unrepairable unless specifically authorized by the applicable stress group of HITCO.
- C. Fluted core sandwich components used for electrical applications such as radomes or navigational antenna housing will require electrical testing in accordance with Document ARTC-4, Paragraph 1, dated July 30, 1960 when the total repaired area is larger than 29.0 square inches in any 24 inches x 24 inches section (or 5 percent). Average one-way power transmission efficiency of the repair shall not be less than 90%. Copies of the ARTC-4 are available from:

Technical Standards Services, Inc.
4024 Mount Royal Blvd
Allison Park, PA 15101
Telephone:(412) 487-7007

2. References

Reference	Title
51-30-03, GENERAL	Nonmetallic Materials
51-70-07, GENERAL	Glass Fabric Reinforced Epoxy Laminates and Nonmetallic Honeycomb Sandwich Repairs - 250°F (121°C) Cure
SOPM 20-30-99	Solvents For Final Cleaning of Composites Before Structural Bonding (Series 99)

3. Material

- A. Material Incorporated into Repair: One or more of the materials listed below are incorporated into part during repair. Refer to 51-30-03, GENERAL for sources of BMS 8-79, BMS 9-3, BMS 8-301, and EA9330.

Table 201: Materials Data

Material	Specification or Source
Fiberglass/Epoxy Prepreg	BMS 8-79
Glass, Fabric Type D, H or H-2 Class 7	BMS 9-3
Milled Glass Fibers 1/32 in. length cationic binder or equivalent	Owens Corning Fiberglass Division
EA 9330 Adhesive Part A Resin Part B Catalyst	Hysol
Laminating Resin	BMS 8-301

- B. Expendable Materials: The following categories are processing aid materials. Only the materials listed under each category are approved for use.

(1) Vacuum Bag Materials (Refer to Table 202/REPAIR GENERAL)

757-200
STRUCTURAL REPAIR MANUAL

Table 202: Vacuum Bag Materials

Material	Specification or Source
Polyvinyl Alcohol (PVA) Film	Open
Nylon Film	Open
Mylar Film	Dupont
Tedlar Film	Dupont

(2) Parting Film Materials (Refer to Table 203/REPAIR GENERAL)

Table 203: Parting Film Materials

Material	Specification or Source
FEP Film (0.001 in. thick)	Dupont
Teflon Film, Perforated 0.03-0.07 dia 0.50 ±0.25 OC perforation	Open

(3) Solvent (Refer to Table 204/REPAIR GENERAL)

Table 204: Solvents

Material	Specification or Source
Acetone	0-A-51
Methyl Ethyl Ketone	TT-M-261
Naphtha	TT-N-95

(4) Peel Ply (Refer to Table 205/REPAIR GENERAL)

Table 205: Peel Ply Materials

Material	Specification or Source
1B301-F 58 Coated Fabric	Hexcel
Style 52006, scoured and heat set nylon	Burlington Ind. Fabrics
Dacron	Burlington Ind. Fabrics
#949 Nylon	Ferro Corp. Cordo Div.
Fluoro Peel No. 3	Dodge Ind.
Taconic 3-25	Taconic Plastics
Release Ply A	Air Tech
Release Ply C	Air Tech
Release Ply F	Air Tech

(5) Liquid Mold Release Materials (Refer to Table 206/REPAIR GENERAL)

Table 206: Liquid Mold Release Materials

Material	Specification or Source
Frekote 33	Frekote, Inc.
Frekote 44	Frekote, Inc.
Frekote 700	Frekote, Inc.

757-200
STRUCTURAL REPAIR MANUAL

(Continued)

Material	Specification or Source
ATACS 7205	ATACS Products Inc.

(6) Miscellaneous (Refer to Table 207/REPAIR GENERAL)

Table 207: Miscellaneous Materials

Material	Specification or Source
Vacuum Bag Sealer Zinc Chromate Type	Open
Pressure Sensitive Tape	Open
Glove, white, lightweight, lint-free	Open
Marking pen, felt tip	Open
Rubber pressure pad	Completely Cured Rubber Open
Thermocouple wire Iron-Constantan 1268T 24 gage or finer	Open
Plaster, Gypsum	SS-P-402
Mandrel Extruded Rubber	Hitco P/N MA20000-91

C. Portable Equipment (Refer to Table 208/REPAIR GENERAL)

Table 208: Portable Equipment

Material	Specification or Source
Quartz Heat Lamp	Open
Electric Heat Blankets 5 watts per square in. min.	Open
Vacuum Reducer	Open

4. Definitions

- A. Bleeder: A loosely woven material such as glass fabric or Osnaburg cloth that will draw off resin around periphery of a part of the repair area and serve as a vacuum contact with the part or the repair area.
- B. Bond Ply: The ply of prepreg material that is placed against the fluted core.
- C. Breather: A loosely woven material such as glass fabric or Osnaburg cloth that will serve as a continuous vacuum path over a part or the repair area but is not in direct contact with the part or the repair area.
- D. Bridging: A condition where one or more plies of prepreg span a radius step of the fluted core without full contact.
- E. Delamination: Separation of fiberglass plies from each other and/or skin plies from core. A delamination can be associated with bridging, drilling and trimming.
- F. Fabric Warp Face: That side of the glass fabric where the majority of yarns are parallel to the selvage.
- G. Fabric Wrinkles: A condition where one or more of the plies of prepreg material are permanently formed into a ridge, depression, or fold.
- H. Fill: The crosswise yarn running at 90 degrees to the warp of the glass fabric reinforcement.
- I. Flutes Orientation: Direction of flutes which are in direct contact with the skins.

STRUCTURAL REPAIR MANUAL

- J. Fracture: A break in the skin which may or may not extend through inner and/or outer skin.
- K. Inner Skin: That side of the part which is cured against the vacuum bag.
- L. Outer Skin: That side of the part which is cured against the mold.
- M. Solid Laminate: A structurally reinforced resin impregnated composite cured to a solid state containing no sandwich layers.
- N. Pin Holes: Small cavities on the tool side of a part.
- O. Puncture: A break in the skin which extends through inner and/or outer skin.
- P. Resin Richness: An area of excess resin, usually occurring at radii steps.
- Q. Resin Ridge: A sharp buildup on surface of a part consisting of only resin.
- R. Selvage: The woven edge of the glass fabric.
- S. Void: An empty, unoccupied area of an assembly. Voids are associated with bridging and resin richness.
- T. Warp: The lengthwise parallel yarns of the glass fabric reinforcements.

5. Facilities Control

A. Vacuum Equipment:

Equipment used to repair structural fluted core sandwich components in accordance with the requirements of this document must be capable of maintaining a minimum vacuum of 20 inches of mercury.

B. Processing Environmental Requirements:

The repair procedures contained herein shall be used only in areas of reasonable cleanliness. Areas containing oil mist, exhaust fumes, gases, soot, rain, dust or other particulate matter are specifically prohibited. Ovens used to accomplish repairs shall provide the temperatures and vacuum pressures required by this specification.

C. Autoclaves:

Autoclaves shall meet the requirements of D6-49327.

6. Preparations

A. General Procedures

- (1) The magnitude of repair that may be accomplished is dependent upon the ability to maintain the original contour and cross section of the structure and to satisfactorily meet the necessary structural, thickness, electrical and drainage requirements.
- (2) Repairs requiring removal and replacement of fluted core and/or skin plies must retain flute orientation and skin construction of the original configuration.

B. Preparation of Materials (Figure 209/REPAIR GENERAL)

WARNING: EPOXY RESINS AND HARDENERS ARE SKIN IRRITANTS AND SENSITIZERS. AVOID BREATHING VAPORS. DO NOT GET IN EYES, ON SKIN, OR ON CLOTHING. WASH HANDS BEFORE EATING OR SMOKING. USE ONLY WITH ADEQUATE VENTILATION.

(1) Resin Systems

- (a) The following resin systems are of room temperature curing variety, and therefore, have limited work life. Unless otherwise specified the components once mixed or blended shall be used within 60 minutes at room temperature. The resin and hardener, listed below, are specified in par. Paragraph 3.A./REPAIR GENERAL

757-200**STRUCTURAL REPAIR MANUAL**

- 1) Resin Mix 1:

Thoroughly blend 100 parts by weight of the resin base (EA 9330A) to 33 parts by weight of the catalyst (EA 9330B).
- (b) A preferable alternative to Resin Mix 2 is Resin Mix 3.
 - 1) Resin Mix 3:

Thoroughly blend resin and catalyst per manufacturer's instructions.

150°F (66°C) curing: Resin and catalyst per BMS 8-301, Class 2

200°F (95°C) curing: Resin and catalyst per BMS 8-301, Class 1
 - (c) All components of the resin systems shall be measured within 5 percent.
 - (d) Unless otherwise specified, any of the resin systems specified may be used.
- (2) Glass Fabric Patch
 - (a) Glass fabric patches may be prepared as follows:
 - 1) Cut a piece of glass fabric by at least 2 inches larger on all sides of the area to be patched.
 - 2) Impregnate the glass cloth with catalysed resin prepared in accordance with Paragraph 6.B.(1)/REPAIR GENERAL and place between two sheets of parting film that are larger than the patch ply by at least 1 inch on all sides.
 - 3) Cut the piece to the desired configuration.
 - (b) When all the pieces are ready for assembly, remove one of the layers of parting film and lay pieces in place, in order of use.
 - (c) This method will eliminate the usual fraying at the edges.
- (3) Precured Patch
 - (a) Make a plaster casting which is the contour of the damaged area and 4.0 inches larger on all sides than the damaged area.
 - (b) Cut ply 1 of epoxy prepreg per BMS 8-79 Type 1581 to the patch configuration per Figure 201/REPAIR GENERAL.
 - (c) Cut ply 2 of epoxy prepreg per BMS 8-79 Type 120 by 0.50 inch larger on all sides than the prepreg material cut per par. (b) above and Figure 201/REPAIR GENERAL.
 - (d) Cut ply 3 of epoxy prepreg per BMS 8-79 Type 1581 by 0.50 inch larger on all sides than the prepreg material cut per par. (c) above and Figure 201/REPAIR GENERAL.
 - (e) Use cast detail prepared per par. (a) above as mold. Prepare mold per Paragraph 6.D./REPAIR GENERAL.
 - (f) Lay up 3 plies of prepreg material prepared per par. b, c and d above and per Figure 201/REPAIR GENERAL.
 - (g) Layup, bag and cure per 51-70-07.

NOTE: Casting shall be made from the outside surface after all finishes have been removed.

Peel ply shall be used when the bag side is the faying surface.
- (4) Core Patch
 - (a) Cast the contour of the damaged area as specified in Paragraph 6.B.(3)(a)/REPAIR GENERAL

757-200**STRUCTURAL REPAIR MANUAL**

- (b) Note core orientation.
- (c) Use cast detail prepared per par. (a) above as mold. Prepare mold per Paragraph 6.D./REPAIR GENERAL
- (d) Use rubber mandrel P/N MA20000-91 cut to proper lengths to create flute configuration.
- (e) Lay up core patch per Figure 202/REPAIR GENERAL, the requirements of Hitco drawing 20000 and specification HPS 195-4.0. Make patch at least 2.0 inches larger on all sides than area to be replaced.
- (f) Bag and cure as given in 51-70-07, GENERAL.
- (g) Trim to net size.

NOTE: Casting shall be done on the outside surface after removal of all finishes.

Peel ply is required on bag side.

Use double back, pressure sensitive adhesive tape to bond rubber mandrel, Hitco P/N MA20000-91, to mold before preparation for layup.

First ply per requirements of specification HPS 195-4.0 may be omitted.

Make core patch with a square or rectangular shape, with radiused corners.

C. Preparation of Repair Surface**(1) Material Removal - Solid Laminate**

- (a) Mark off the repair area.
- (b) Taper sand the area adjacent to the damaged portion.
- (c) Remove material by sanding.
 - 1) Use 80-grit or finer sandpaper on solid laminate structure.
- (d) Do not sand closer than 0.50 in. (1.27 cm) from end of part or end of flutes per Figure 203/REPAIR GENERAL.
- (e) When removal of material at the solid laminate or edge band interferes with the 0.50 in. (1.27 cm) minimum requirements per Figure 203/REPAIR GENERAL, remove material to produce a beveled edge with a very shallow taper and a circular or oval shaped periphery.

(2) Area Where Removal of Material is not required, slightly abrade surface with 150-grit or finer sandpaper. Do not sand into glass fabric.**(3) Cleaning**

- (a) Remove all dust and foreign materials by vacuum. Air blow is prohibited.
- (b) Clean surface with a clean, lint-free cloth moistened with solvent, Series 99 (AMM/SOPM 20-30-99).
- (c) Let dry.
- (d) Protect surface after cleaning.

D. Preparation of Tool Surfaces - Tool surfaces on which materials are bonded or cured, or which may come in contact with adhesive or resin during the cure cycle, shall be prepared according to this section.**(1) Clean tool surfaces to be released coated with a solvent.**

- (a) For oils, greases, or fingerprints use solvents, Series 99 (AMM/SOPM 20-30-99).

STRUCTURAL REPAIR MANUAL

- (2) Parting films or mold releases listed in Paragraph 3.B./REPAIR GENERAL are applied to the tool surface prior to part fabrication. Mold releases that are applied to a clean, uncoated tool surface shall be applied in three coats with a minimum of 15 minutes drying time between coats. The tool shall then be baked at $250 \pm 10^{\circ}\text{F}$ ($121 \pm 6^{\circ}\text{C}$) for 30 minutes prior to start of layup, except for Frekote 700 which does not require baking but should be air dried 15 minutes at room temperature $75 \pm 10^{\circ}\text{F}$ ($24 \pm 6^{\circ}\text{C}$) prior to layup.
- (3) Mold releases that are applied to a tool surface which has previously had a mold release baked on shall be dried as follows prior to layup. Both air temperature and tool temperature shall be within the required range (Refer to Table 209/REPAIR GENERAL).

Table 209: Mold Release Data

MATERIAL	TEMPERATURE RANGE
Frekote 33	30 minutes at 60 to 100°F (16 to 38°C)
Frekote 44	60 minutes at 60 to 120°F (16 to 49°C)
ATACS 7205	60 minutes at 60 to 120°F (16 to 49°C)
Frekote 700	15 minutes at 60 to 100°F (16 to 38°C)

- (4) When a polyester integral breather/release parting material is used, oven cure the fabric impregnated with silicone rubber for four hours at 350°F (177°C) prior to initial use. Perforated FEP must be used between this material and repair area at all times.

7. Repair Procedures

A. Repair of Cloth Wrinkles

- (1) Solid Laminate Structure of Edgeband
- Mark off the area to be repaired. Sand off wrinkles above surface of edgeband using 80-grit or finer sandpaper. Final sanding must be done with 150-grit or finer sandpaper.
 - Determine number of plies that have been sanded and remove damaged plies as follows:
 - Cut and peel back each ply in a step pattern extending a minimum of 0.50 inch from damaged area for each damaged ply as shown in Figure 204/REPAIR GENERAL, Detail I.
 - Taper sand area where each ply was removed.
 - Remove finish from top skin surface a minimum of 1.5 inch back from edge of taper and sand to remove gloss. Do not sand into fabric.
 - Replace plies that have been removed plus one extra ply in accordance with Paragraph 8.A./REPAIR GENERAL and Detail II, Figure 204/REPAIR GENERAL, Detail II. Use only glass fabric per specification BMS 9-3 Type D.
 - Refinish in accordance with Paragraph 10./REPAIR GENERAL
- (2) Fluted Core Structure Skins - Repair in accordance with Paragraph 7.A.(1)/REPAIR GENERAL with the following exceptions:
- Use glass fabric per specification BMS 9-3 Type D to replace 120 style prepreg material removed.
 - Repair is limited to wrinkles not penetrating through the bond ply.
 - It is prohibited to sand into fabric of the bond ply.
 - Repair damaged bond ply in accordance with Paragraph 8.B.(3)/REPAIR GENERAL

B. Repair of Voids and Delaminations

STRUCTURAL REPAIR MANUAL

- (1) Drill small holes into void about 1.0 inch apart. Drill at least two holes at both ends of void. Select hole size to ensure tight fit of hypodermic needle that will be used in filling the holes. Outline void area as shown in Figure 205/REPAIR GENERAL, Detail I.
- (2) Using hypodermic syringe or equivalent, inject resin mix prepared in accordance with Paragraph 6.B.(1)/REPAIR GENERAL through one hole, permitting air to escape through the others.
- (3) Observe resin flow, continue to inject resin until void is filled.
- (4) When the voids have been filled, cover the holes with masking tape (Detail II, Figure 205/REPAIR GENERAL).
- (5) Apply a minimum of 2 psi pressure.
- (6) Cure per Figure 209/REPAIR GENERAL.
- (7) When voids occur in fluted core sandwich, extreme care should be exercised to prevent flow of resin into flutes. This may be realized as follows:
 - (a) Apply light pressure to the hypodermic syringe to allow the resin mix to flow slowly.
 - (b) Observe the propagation of the resin mix inside void.
 - (c) When the resin mix starts to flow into flute, stop applying pressure.
 - (d) Allow the resin to cure without application of pressure.
 - (e) Continue the same procedure as required to fill void.
 - (f) Verify that void is filled.

NOTE: Pressure shall not exceed 5 psi or 10 in. of mercury vacuum, when curing fluted core sandwich. Vacuum reducer shall be used to maintain maximum allowable vacuum.

Pressure shall not exceed 15 psi on solid laminate. Full vacuum may be used.

Removal and addition of surface finishes are not required.

C. Repair of Puncture or Mislocated Holes

- (1) Solid Laminate Structure
 - (a) Puncture is 0.50 inch or smaller in any direction.
 - 1) Mark off area to be repaired.
 - 2) Countersink both sides of hole per Figure 206/REPAIR GENERAL.
 - 3) Remove all finishes 0.25 inch minimum beyond the edge of the countersink.
 - 4) Prepare resin mix in accordance with Paragraph 6.B.(1)/REPAIR GENERAL.
 - 5) Add 20 percent by weight of the milled glass fiber to the catalysed resin mix. Mix to the milled glass fiber evenly dispersed.
 - 6) Fill the hole with mixture prepared per par. (5) above.
 - 7) Cure per requirements of Figure 209/REPAIR GENERAL.
 - 8) Refinish per requirements of par. Paragraph 10./REPAIR GENERAL.
 - (b) Puncture is larger than 0.50 inch in any direction. Repair in accordance with Paragraph 7.A.(1)/REPAIR GENERAL and Figure 207/REPAIR GENERAL.
- (2) Fluted Core Structure - Repair in accordance with Paragraph 8.B./REPAIR GENERAL.

D. Repair of Fracture

STRUCTURAL REPAIR MANUAL

- (1) Solid Laminate Structure - Repair in accordance with Paragraph 7.A.(1)/REPAIR GENERAL.
- (2) Fluted Core Structure
 - (a) Fracture Penetrated Through Skin - Repair in accordance with Paragraph 8.B.(3)/REPAIR GENERAL.
 - (b) Fracture Not Penetrated Through Skin - Repair in accordance with Paragraph 7.A.(2)/REPAIR GENERAL.

8. Replacement of Plies**A. Solid Laminate**

- (1) Mark off the area required for ply replacement.
- (2) Prepare glass fabric patches in accordance with Paragraph 6.B.(2)/REPAIR GENERAL.
- (3) Cut glass fabric patches using the same fabric and warp orientation as specified on the engineering drawing. There shall be a glass fabric patch applied for every ply removed plus one extra ply. Cut all patches 0.50 inch larger on all edges than the ply that was removed. The extra ply shall be 1.0 inch larger on all edges than the first ply removed and shall be glass fabric per specification BMS 9-3, Type D (Figure 204/REPAIR GENERAL and Figure 208/REPAIR GENERAL).
- (4) Prepare repair surface as given in Paragraph 6.C./REPAIR GENERAL.
- (5) Lay up glass fabric patches. Use only glass fabric per specification BMS 9-3, Type D.
- (6) Place layer of perforated parting film over the repaired area.
- (7) Lay bleeder cloth over parting film. Edge bleeder may be used as an option (ply for ply) or in addition (Figure 208/REPAIR GENERAL).
- (8) Stretch a piece of vacuum bag material over entire patch area. Install vacuum port outside of the patch area and in direct contact with bleeder. Seal edges.
- (9) Evacuate to a minimum vacuum of 20 inches of mercury and force excess resin from patch with teflon squeegee.
- (10) Cure the repair. Maintain a minimum of 20 inches of mercury during the entire cure cycle. See Figure 209/REPAIR GENERAL for the minimum time and temperature requirements.
- (11) Refinish in accordance with par. Paragraph 10./REPAIR GENERAL
- (12) Sand off bleeder as required. DO NOT SAND INTO FABRIC.

B. Fluted Core Skin

Replacement of plies on each skin shall be treated separately. Damage to both skins shall be considered as damage to each skin separately.

- (1) Replacement of Skin (One Ply)
 - (a) Mark off area requiring ply replacement.
 - (b) Prepare glass fabric in accordance with Paragraph 6.B.(2)/REPAIR GENERAL and Figure 210/REPAIR GENERAL.
 - (c) Cut glass fabric patches using the same fabric and warp orientation as required on the engineering drawing. There shall be a glass fabric patch applied for the ply removed, plus one extra ply. The patch will be cut 0.50 inch larger on all edges than the ply that was removed. The extra ply shall be 1.0 inch larger on all edges than the ply (Figure 210/REPAIR GENERAL) and shall be glass fabric per specification BMS 9-3, Type D.

STRUCTURAL REPAIR MANUAL

- (d) Prepare repair surface in accordance with Paragraph 6.C./REPAIR GENERAL. Extreme care should be exercised to prevent damage to the bond ply. Do not sand into fabric of the bond ply.
- (e) Lay up glass fabric patches.
- (f) Place layer of perforated parting film over the repaired area.
- (g) Apply pressure 2 psi minimum and 5 psi maximum, and force excess resin from patch with a teflon squeegee.
- (h) Cure the repair at room temperature as given in Figure 209/REPAIR GENERAL.
- (i) Refinish in accordance with Paragraph 10./REPAIR GENERAL.

NOTE: The extra repair ply shall be glass fabric per specification BMS 9-3, Type D. Vacuum bagging in accordance with Paragraph 7.A.(6) thru 7.A.(8) is optional. Evacuate to a minimum of 10 inches of mercury vacuum when vacuum bag option is used.

(2) Replacement of Skins (Two Plies)

- (a) Mark off area requiring ply replacement.
- (b) Prepare glass fabric in accordance with par. Paragraph 6.B.(2)/REPAIR GENERAL and Figure 211/REPAIR GENERAL.
- (c) Cut glass fabric patches using the same fabric and wrap orientation as required on the Engineering drawing. There shall be a glass fabric patch applied for every ply removed plus one extra ply. All patches will be cut 0.50 inch larger on all edges than the ply that was removed. The extra ply shall be 1.5 inch larger on all edges than the first ply removed (see Figure 211/REPAIR GENERAL) and shall be as given in specification BMS 9-3, Type D.
- (d) Prepare repair surface in accordance with par. Paragraph 6.C./REPAIR GENERAL and Figure 211/REPAIR GENERAL.
- (e) Layup glass fabric patches.
- (f) Place layer of perforated parting film over the repaired area.
- (g) Apply pressure 2 psi minimum and 5 psi maximum, and force excess resin from patch with a teflon squeegee.
- (h) Cure the repair at room temperature per Figure 209/REPAIR GENERAL.
- (i) Refinish in accordance with Paragraph 10./REPAIR GENERAL.

NOTE: Vacuum bagging in as given in Paragraph 7.A.(6) through 7.A.(8).

Evacuate to a minimum of 5 inches and maximum of 10 inches of mercury vacuum bag option is used.

(3) Replacement of Skins (Three Plies)

- (a) Mark off area requiring three ply replacement.
- (b) Prepare precured patch in accordance with par. Paragraph 6.B.(3)/REPAIR GENERAL.
- (c) Prepare repair surface in accordance with Paragraph 6.C./REPAIR GENERAL. Extreme care should be exercised to prevent damage to core, area around repaired surfaces and drainage areas.
- (d) Prepare resin system in accordance with par. Paragraph 6.B.(1)/REPAIR GENERAL.

STRUCTURAL REPAIR MANUAL

- (e) Prepare pressure pad for the nondamaged skin in accordance with par. Paragraph 6.B.(3)/REPAIR GENERAL with the following exceptions:
 - 1) Use eight plies of epoxy prepreg per specification BMS 8-79 Type 1581.
 - 2) The pressure pad shall be a minimum of 6.0 inches larger than the damage area on all sides and circular in shape.
- (f) Temporarily bond prepared pressure pad to the undamaged skin with double-back pressure sensitive adhesive tape.
- (g) Bond precured patch in accordance with specification HPS 195-4.0 and the following requirements.
- (h) Overlay one extra repair ply prepared in accordance with Paragraph 6.B.(2)/REPAIR GENERAL (Figure 212/REPAIR GENERAL)..
- (i) Apply pressure (2 psi min, 5 psi max).

NOTE: Vacuum bag may be used as optional method to apply pressure. The vacuum reading under the bag shall not exceed 10 inches of mercury.

Double-back, pressure sensitive tape shall cover the entire faying surface at the pressure pad.

Oven cure the pressure pad, under a minimum of 20 inches of mercury throughout the cure cycle, is optional.

- (j) Cure the repair as given in Figure 209/REPAIR GENERAL.

9. Replacement of Core**A. Replacement of Core and One Skin**

- (1) Mark off area to be prepared.
- (2) Prepare repair area as given in Paragraph 6.C./REPAIR GENERAL. Remove core in a square or rectangular shape.
- (3) Prepare precured patch as given in Paragraph 6.B.(3)/REPAIR GENERAL.
- (4) Prepare core patch as given in Paragraph 6.B.(4)/REPAIR GENERAL.
- (5) Bond precured patch to precured core patch in accordance with specification HPS 195-4.0.
- (6) Prepare pressure pad for the nondamaged skin as given in Paragraph 6.B.(3)/REPAIR GENERAL with the following exception:
 - (a) Use eight plies of epoxy prepreg per specification BMS 8-79 Type 1581.
 - (b) The pressure pad shall be a minimum of 6.0 inches larger than the damaged area on all sides with a circular shape.
 - (c) Oven cure of pressure pad, under a minimum of 20 inches of vacuum pressure throughout the cure cycle, is optional.
- (7) Temporarily bond prepared pressure pad to the undamaged skin with double-back, pressure sensitive adhesive tape. The tape shall cover the entire faying surface at pressure pad.

757-200**STRUCTURAL REPAIR MANUAL**

- (8) Bond detail prepared as given in Paragraph 9.A.(5)/REPAIR GENERAL above to the part plus one extra repair ply as given in Paragraph 8.B.(3)/REPAIR GENERAL and Figure 213/REPAIR GENERAL Detail I.

NOTE: Extreme care should be exercised to:

Ensure patch is properly located.

Prevent damage to area adjacent to the repair.

Maintain original flutes orientation.

Prevent damage to drainage.

Ensure all dust and foreign materials are removed.

Core gap shall not exceed 0.020 in. (0.051 cm)(Figure 213/REPAIR GENERAL, Detail II).

B. Replacement of Core and Both Skins

- (1) Prepare pressure pad for the less damaged side as given in Paragraph 6.B.(3)/REPAIR GENERAL with the following exceptions:
- (a) Use eight plies of epoxy prepreg per specification BMS 8-79 Type 1581.
 - (b) The pressure pad shall be circular in shape and shall be of 6.0 inches larger than the damaged area on all sides.
- (2) Temporarily bond prepared pressure pad to the less damaged skin with double-back, pressure sensitive adhesive tape.
- (3) Repair the more damaged side as given in Paragraph 9.A./REPAIR GENERAL and Figure 214/REPAIR GENERAL.
- (4) Remove pressure pad and double-back, pressure sensitive adhesive tape.
- (5) Repair the less damaged side as given in Paragraph 8.B.(3)/REPAIR GENERAL.

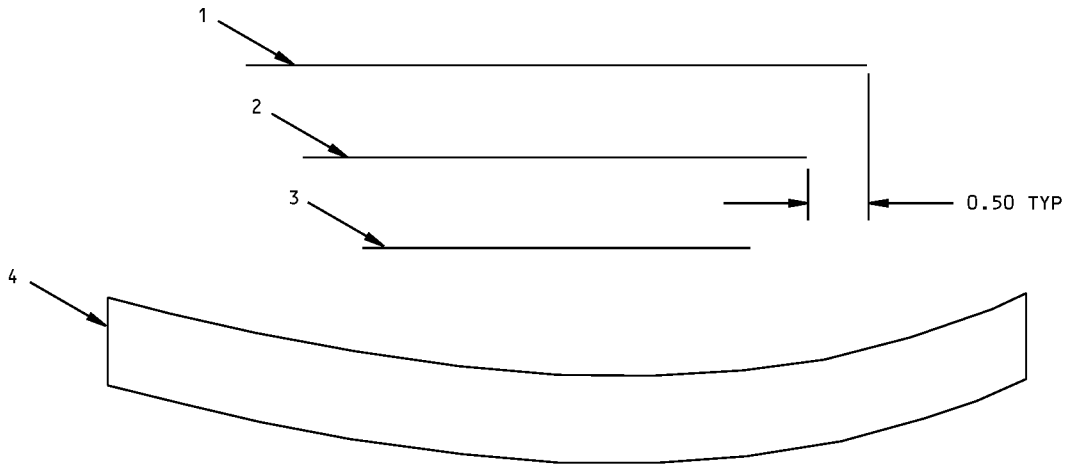
NOTE: Double-back, pressure sensitive adhesive tape shall cover the entire faying surface at the pressure pad.

Oven cure of pressure pad, under a minimum of 20 in/Hg (68 kPa) vacuum pressure throughout the cure cycle, is optional.

10. Refinishing

- A. Remove all bagging material and lightly sand surface and edge of the top most ply to produce a feather edge.
- B. Apply finish in accordance with drawing requirement.

757-200
STRUCTURAL REPAIR MANUAL



ITEM	MATERIAL
1	PREPREG PER BMS 8-79 TYPE 1581
2	PREPREG PER BMS 8-79 TYPE 120
3	PREPREG PER BMS 8-79 TYPE 1581
4	CAST DETAIL (MOLD)

INNER SKIN LAYUP

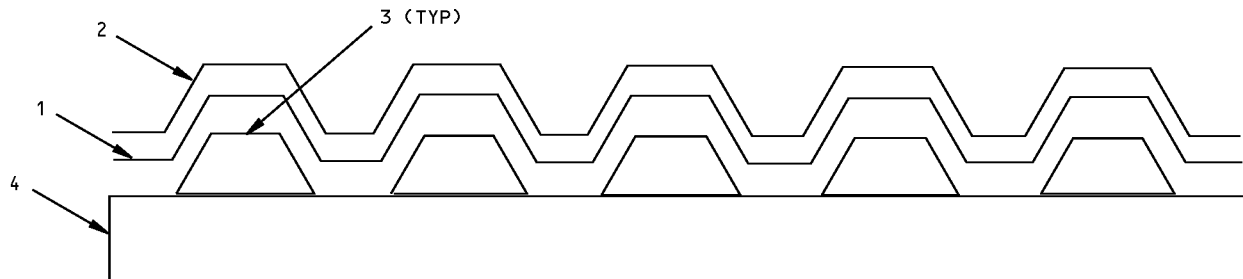
- PLY 1 (AGAINST MOLD)
- PLY 2
- PLY 3

OUTER SKIN LAYUP

- PLY 3 (AGAINST MOLD)
- PLY 2
- PLY 1

Layup Diagram - Precured Patch
Figure 201

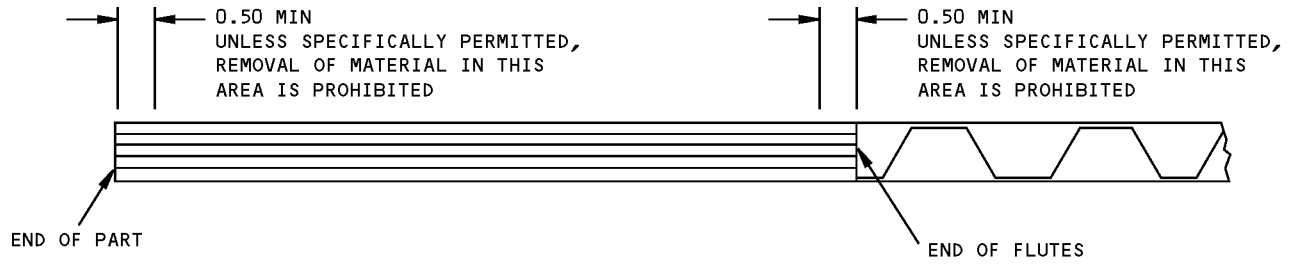
**757-200
STRUCTURAL REPAIR MANUAL**



ITEM	MATERIAL
1	PREPREG PER BMS 8-79 TYPE 120
2	PREPREG PER BMS 8-79 TYPE 1581
3	MANDREL HITCO P/N MA20000-91
4	CAST DETAIL (MOLD)

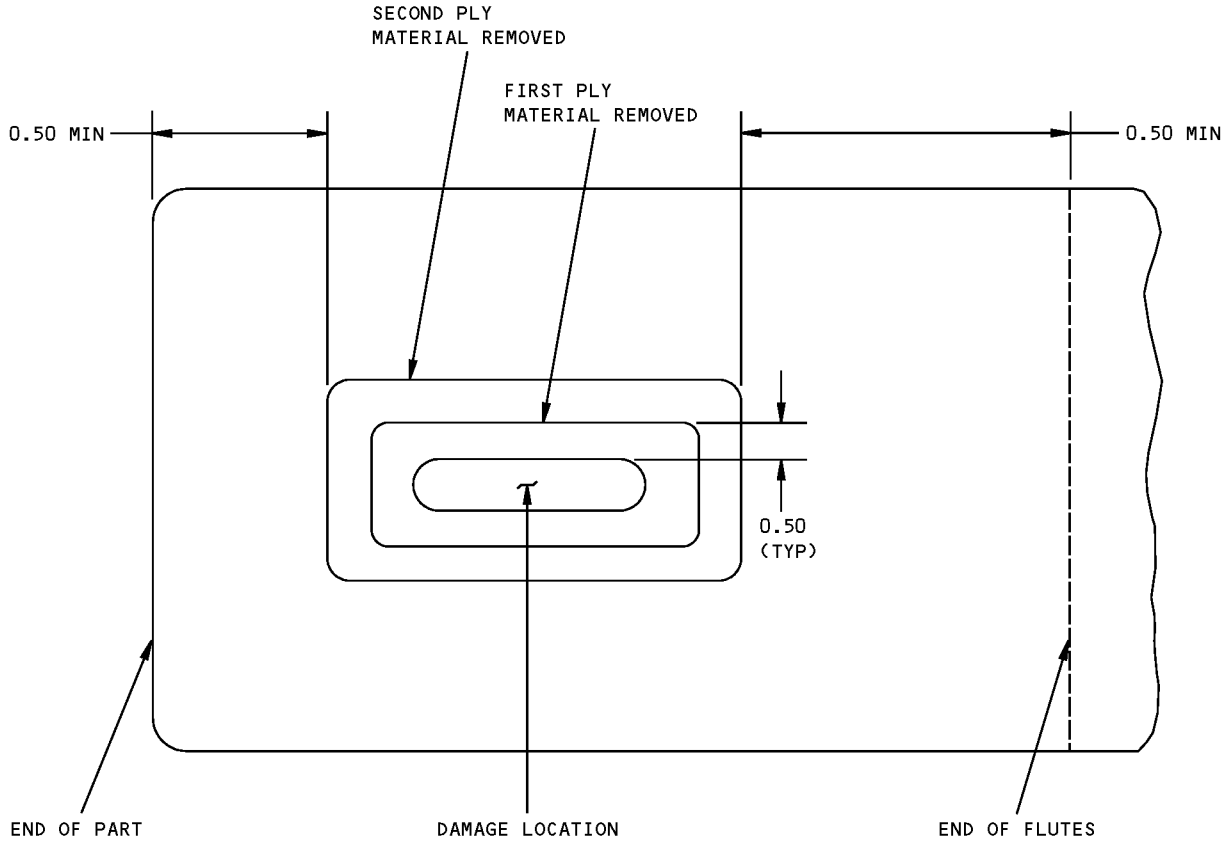
**Core Patch Layup
Figure 202**

757-200
STRUCTURAL REPAIR MANUAL



Solid Laminate Edgeband Area
Figure 203

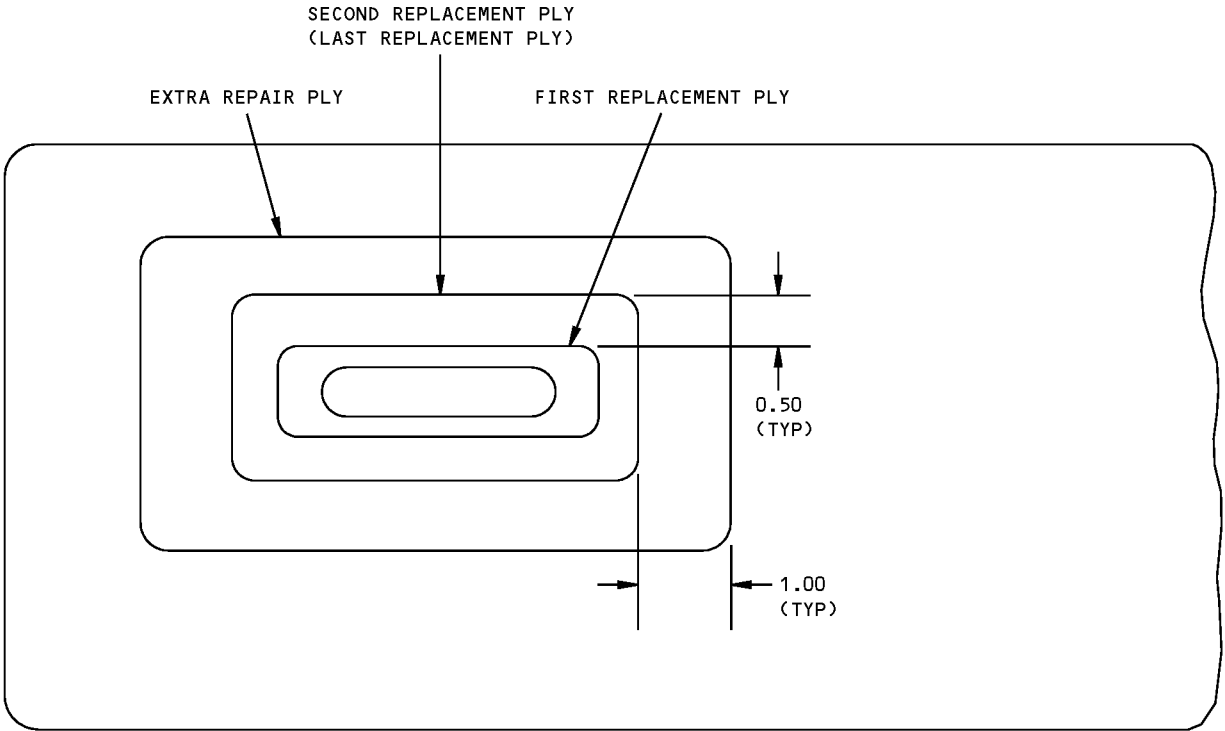
**757-200
STRUCTURAL REPAIR MANUAL**



**MATERIAL REMOVAL PROCEDURE
DETAIL I**

**2 Ply Damage Repair
Figure 204 (Sheet 1 of 2)**

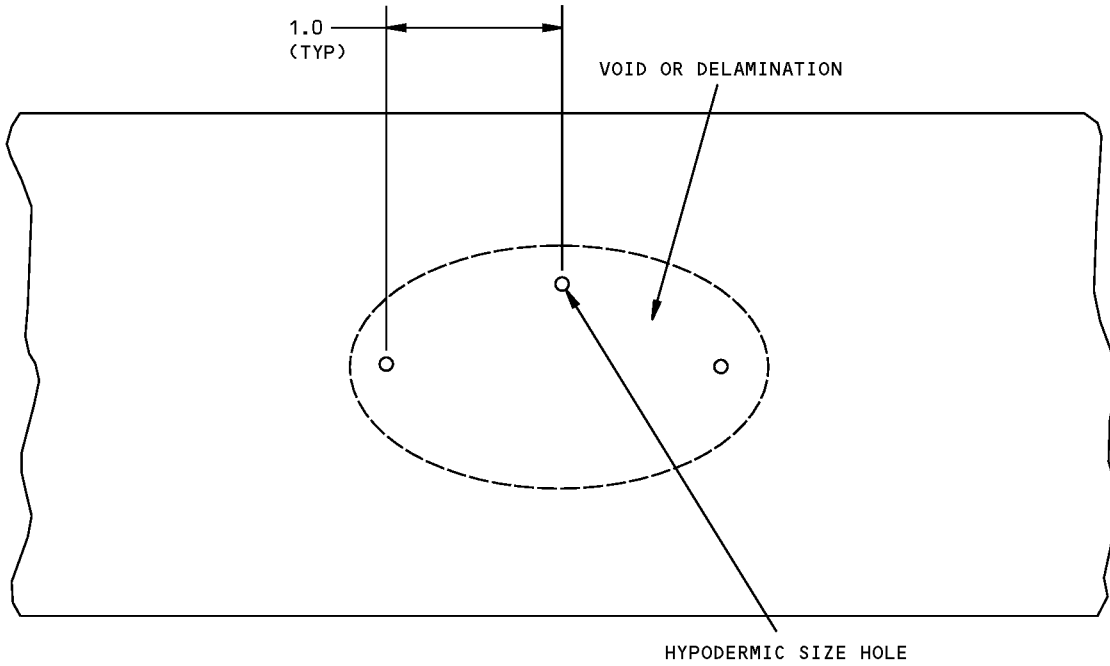
757-200
STRUCTURAL REPAIR MANUAL



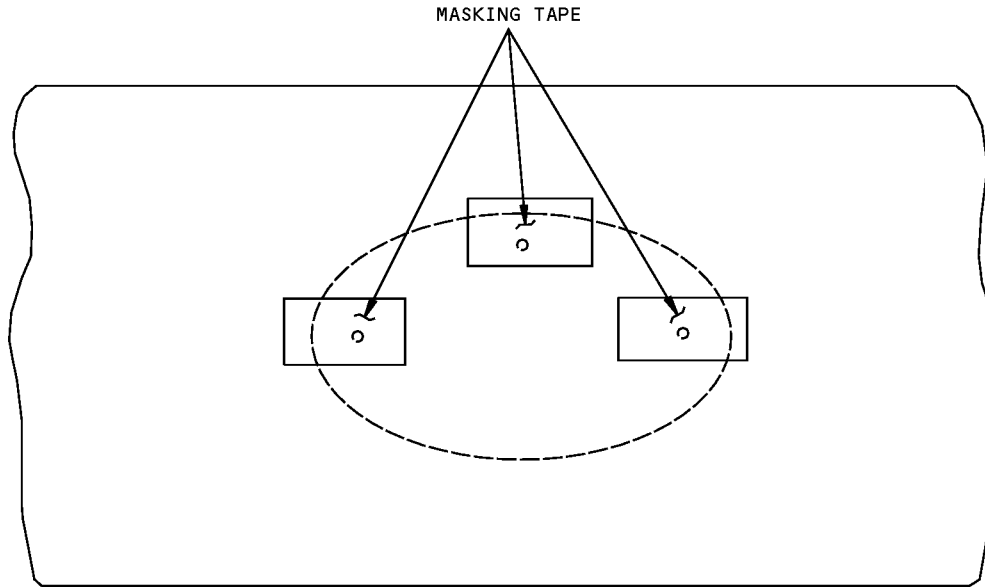
DETAIL II

2 Ply Damage Repair
Figure 204 (Sheet 2 of 2)

757-200
STRUCTURAL REPAIR MANUAL



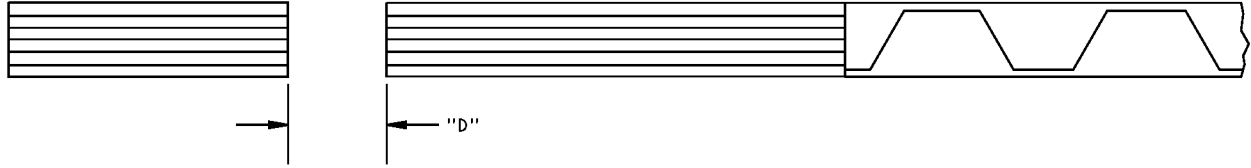
STEP 1
DETAIL I



STEP 2
DETAIL II

Repair Of Voids And Delaminations
Figure 205

**757-200
STRUCTURAL REPAIR MANUAL**



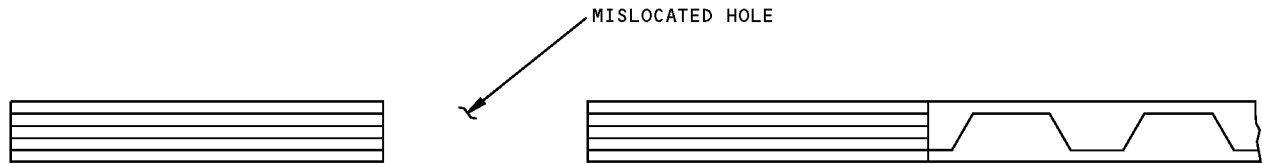
MISLOCATED HOLE DIAMETER "D"
DETAIL I



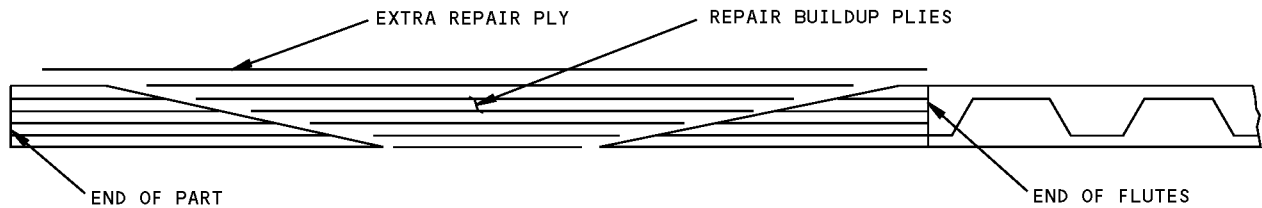
COUNTERSINK 100° x 1.5 "D" DIAMETER (BOTH SIDES)
DETAIL II

**Mislocated Hole Or Puncture Diameter "D" Repair
Figure 206**

757-200
STRUCTURAL REPAIR MANUAL



MISLOCATED HOLE OR PUNCTURE LARGER THAN 0.50 INCH

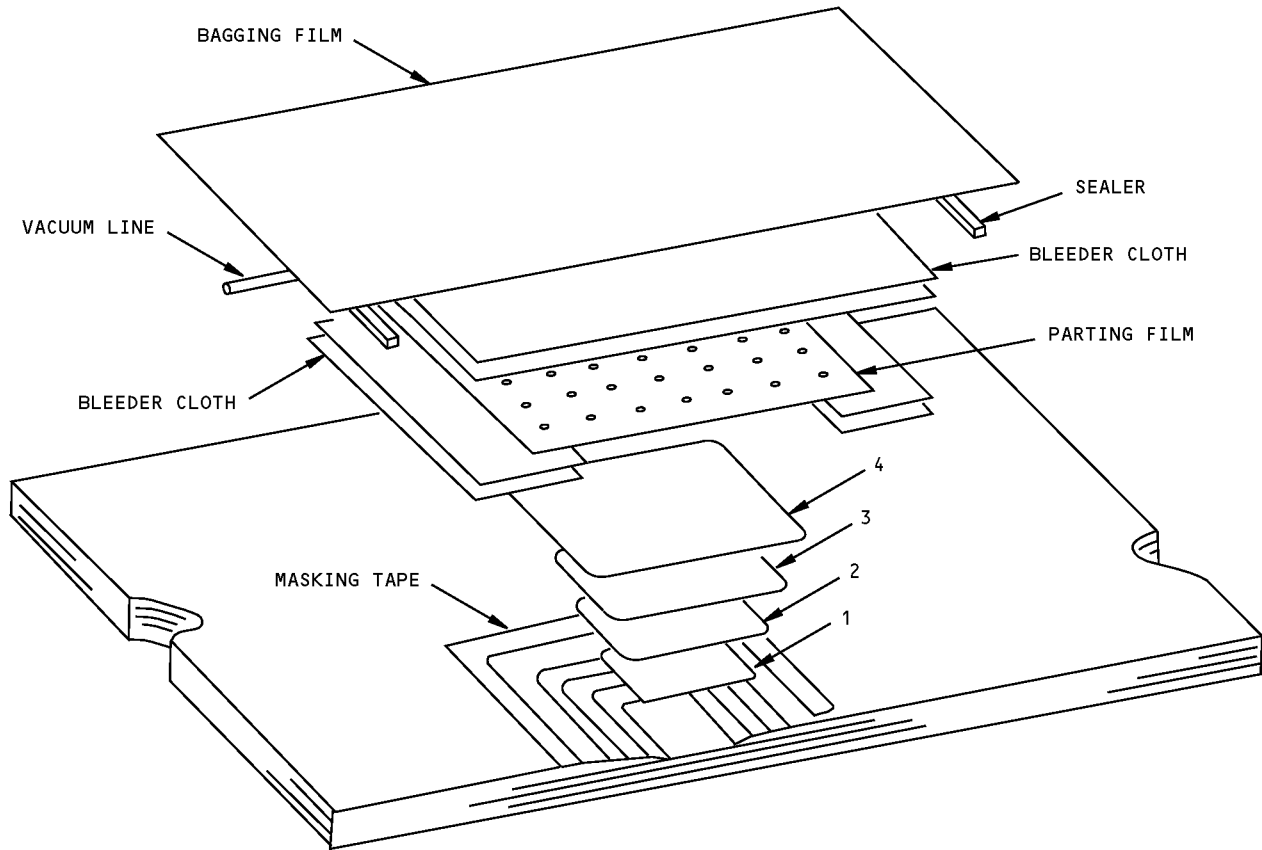


NOTES

- REMOVE MATERIAL TO OBTAIN 10° SLOPE MAXIMUM
- HIGHER SLOPE IS PERMITTED ONLY IN AREAS WHERE 0.50 MINIMUM REQUIREMENTS PER FIGURE 203 CANNOT BE MET
- MATERIAL SHALL BE REMOVED IN OVAL SHAPE TO MEET 10° SLOPE MAXIMUM IN REMAINING AREA

**Repair of Mislocated Hole or Puncture Larger than 0.50 Inch
 Figure 207**

**757-200
STRUCTURAL REPAIR MANUAL**

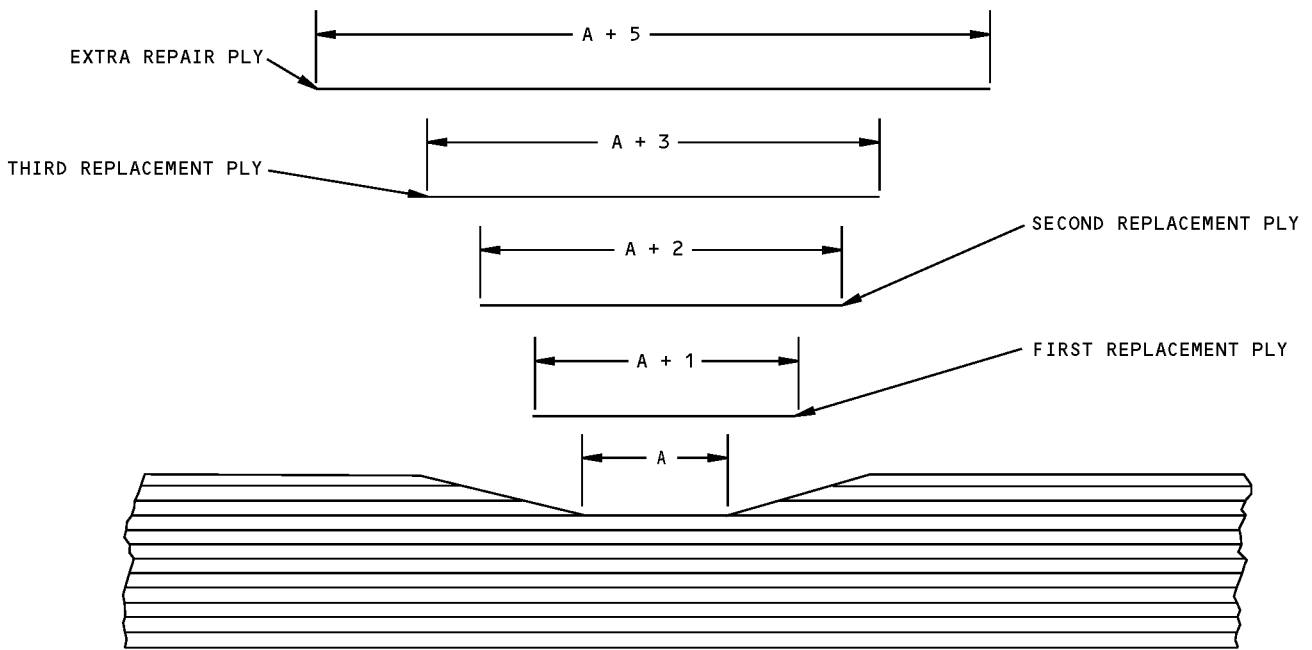


DETAIL I

ITEM	MATERIAL
1	FIRST REPLACEMENT PLY (PATCH)
2	SECOND REPLACEMENT PLY (PATCH)
3	THIRD REPLACEMENT PLY (PATCH)
4	EXTRA REPLACEMENT PLY (PATCH)

**3 Ply Replacement or Repair of Solid Laminate Structure
Figure 208 (Sheet 1 of 2)**

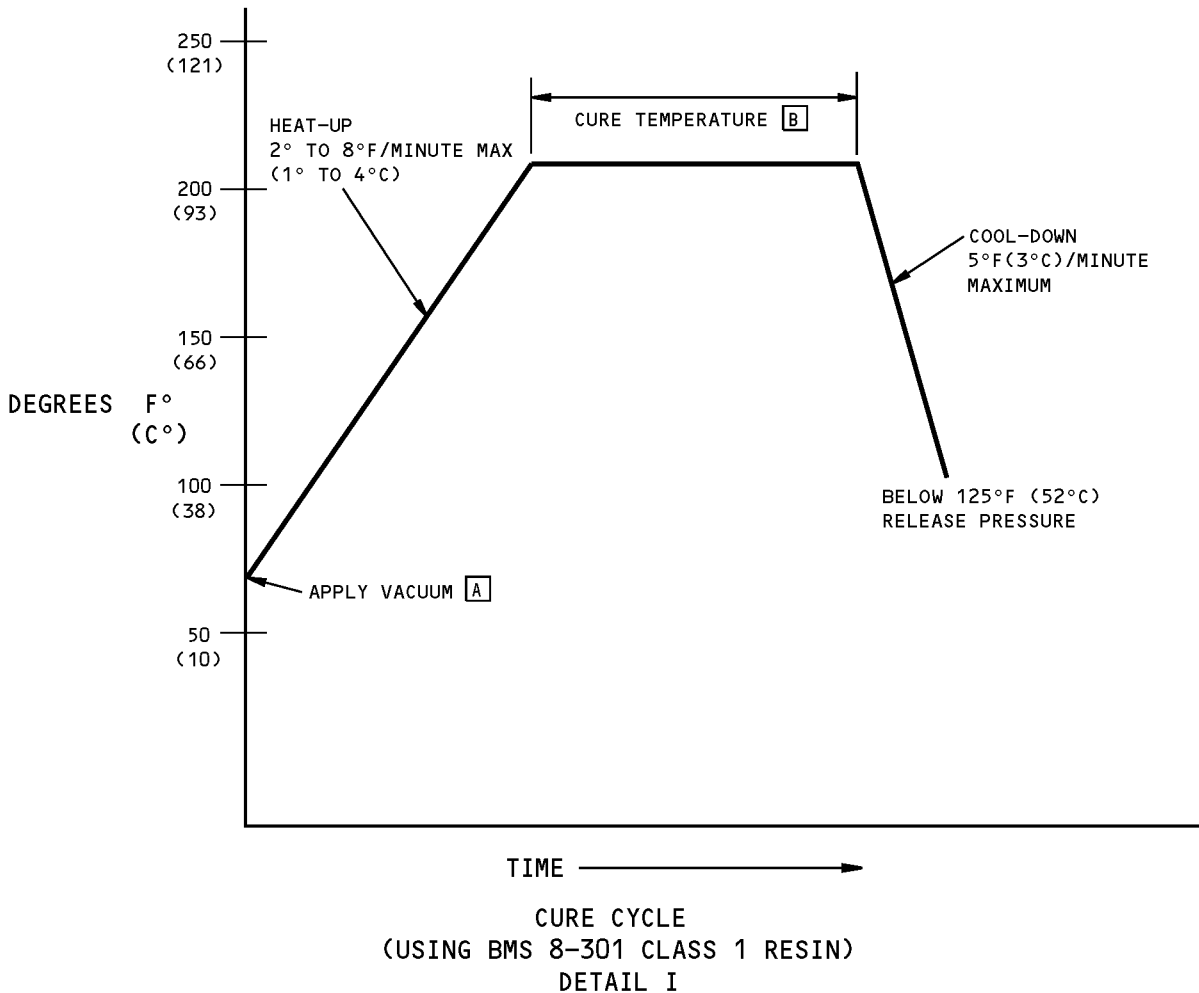
757-200
STRUCTURAL REPAIR MANUAL



DETAIL II

3 Ply Replacement or Repair of Solid Laminate Structure
Figure 208 (Sheet 2 of 2)

757-200
STRUCTURAL REPAIR MANUAL

**NOTES**

- WHEN USING BMS 8-301 CLASS 2, OR EA 9330 RESINS, SURFACE TEMPERATURE SHOULD NOT EXCEED 160°F (71°C)
- FOR OPTIMUM PROPERTIES, CURE BMS 8-301 CLASS 2 FOR 180 MINUTES AT 150°F (66°C)
- SEE DETAIL I FOR CURING BMS 8-301 CLASS I
- SEE DETAIL II FOR CURING EA 9330

- A** MAINTAIN 22 INCHES VACUUM MINIMUM DURING ENTIRE CURE CYCLE
- B** CURE BMS 8-301 CLASS 1 RESIN FOR 220 MINUTES AT 200 ±10°F (93 ±6°C) OR 150 MINUTES AT 250 ±10°F (121 ±6°C)

Resin Cure Cycle
Figure 209 (Sheet 1 of 2)

**757-200
STRUCTURAL REPAIR MANUAL**

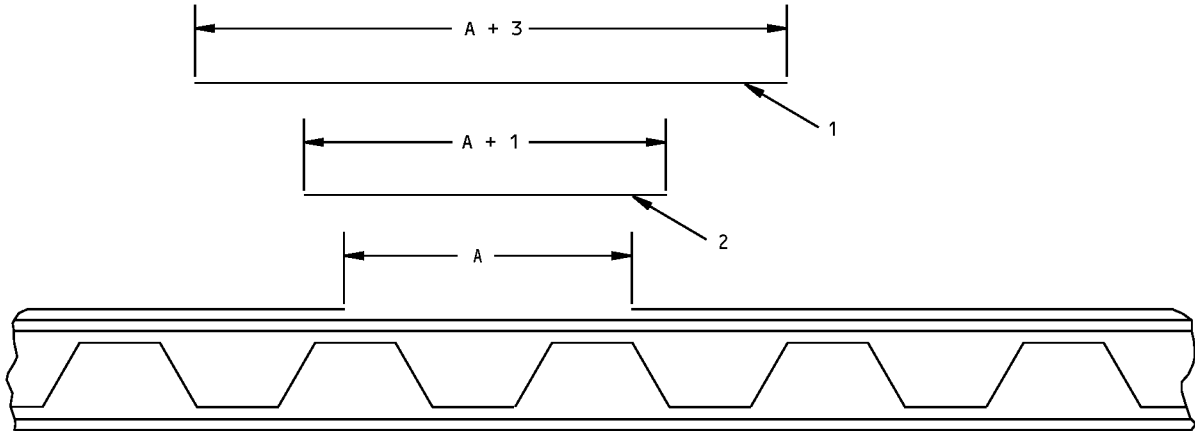


TIME IN HOURS
(CURE CURVE FOR EA 9330 A/B ADHESIVE)

DETAIL II

**Resin Cure Cycle
Figure 209 (Sheet 2 of 2)**

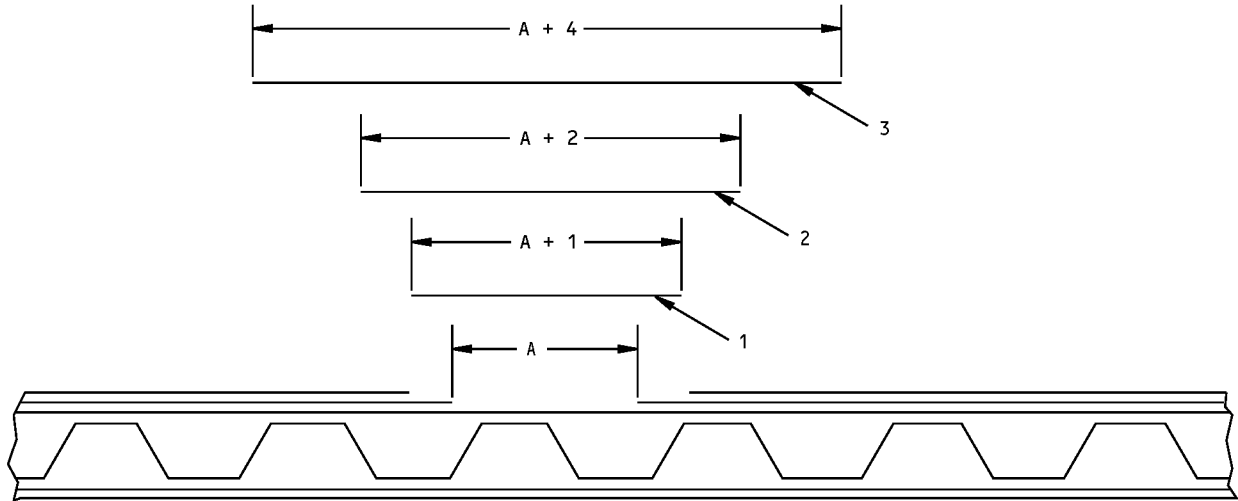
**757-200
STRUCTURAL REPAIR MANUAL**



ITEM	MATERIAL
1	REPLACEMENT PLY, GLASS FABRIC PER BMS 9-3 TYPE H OR H2
2	EXTRA REPAIR PLY, GLASS FABRIC PER BMS 9-3 TYPE D

**One Ply Repair or Replacement of Fluted Core Sandwich Structure
Figure 210**

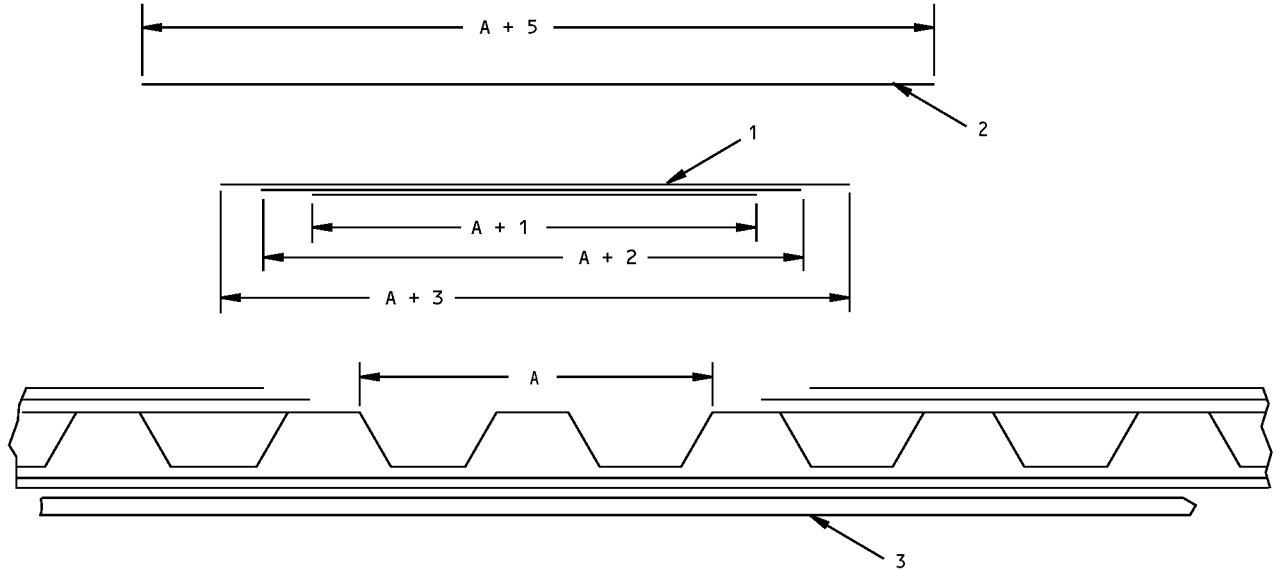
**757-200
STRUCTURAL REPAIR MANUAL**



ITEM	MATERIAL
1	REPLACEMENT PLY, GLASS FABRIC PER BMS 9-3 TYPE D
2	REPLACEMENT PLY, GLASS FABRIC PER BMS 9-3 TYPE H OR H2
3	EXTRA REPAIR PLY, GLASS FABRIC PER BMS 9-3 TYPE D

**Two Ply Repair or Replacement of Fluted Core Sandwich Structure
Figure 211**

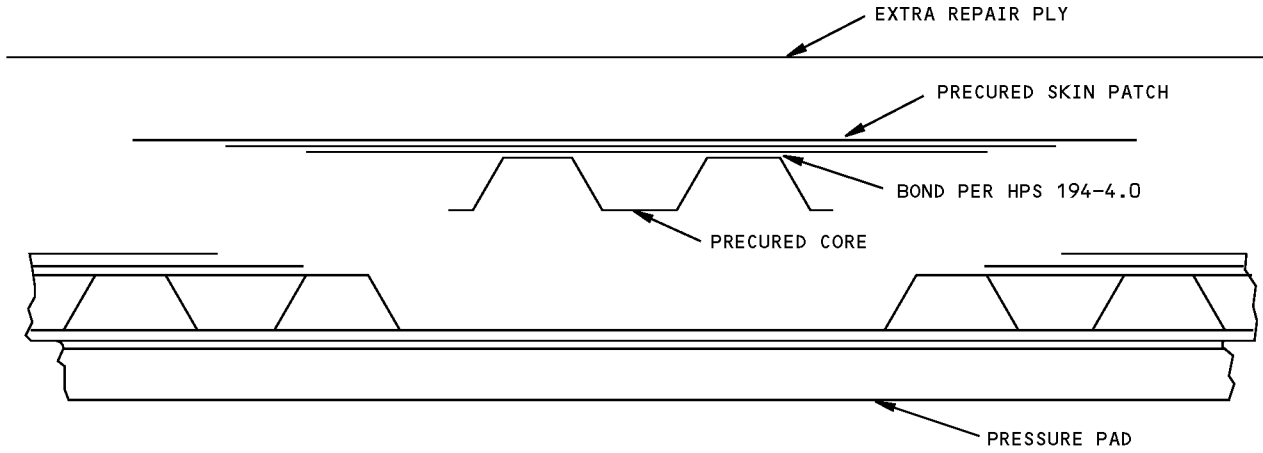
**757-200
STRUCTURAL REPAIR MANUAL**



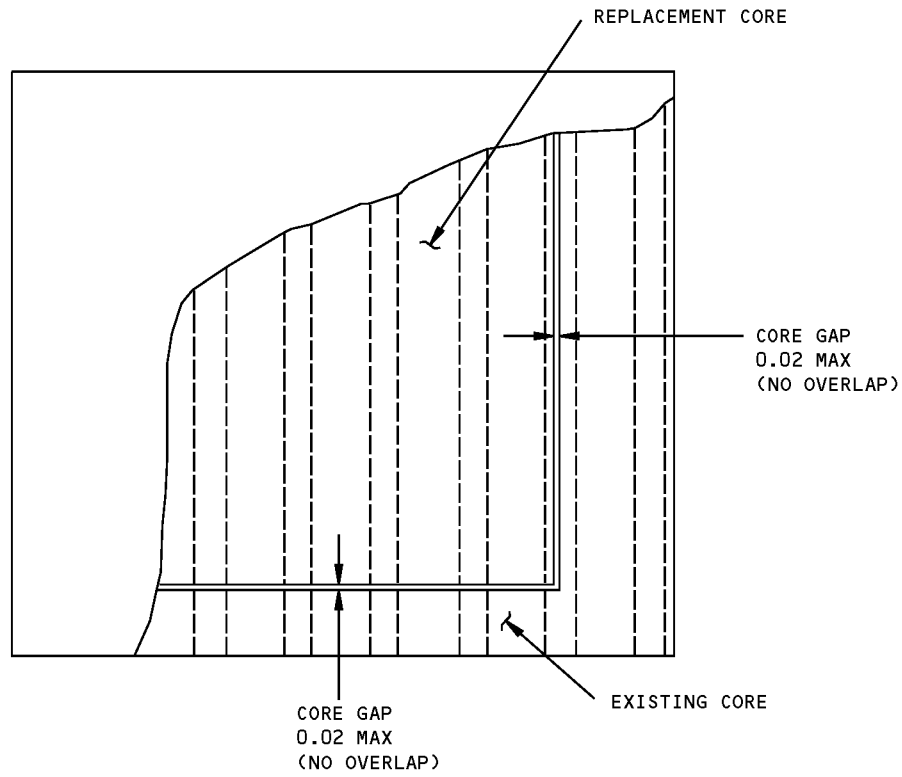
ITEM	MATERIAL
1	PRECURED PATCH
2	EXTRA REPAIR PLY, GLASS FABRIC PER BMS 9-3 TYPE D
3	PRESSURE PAD

**Skin Replacement
Figure 212**

**757-200
STRUCTURAL REPAIR MANUAL**



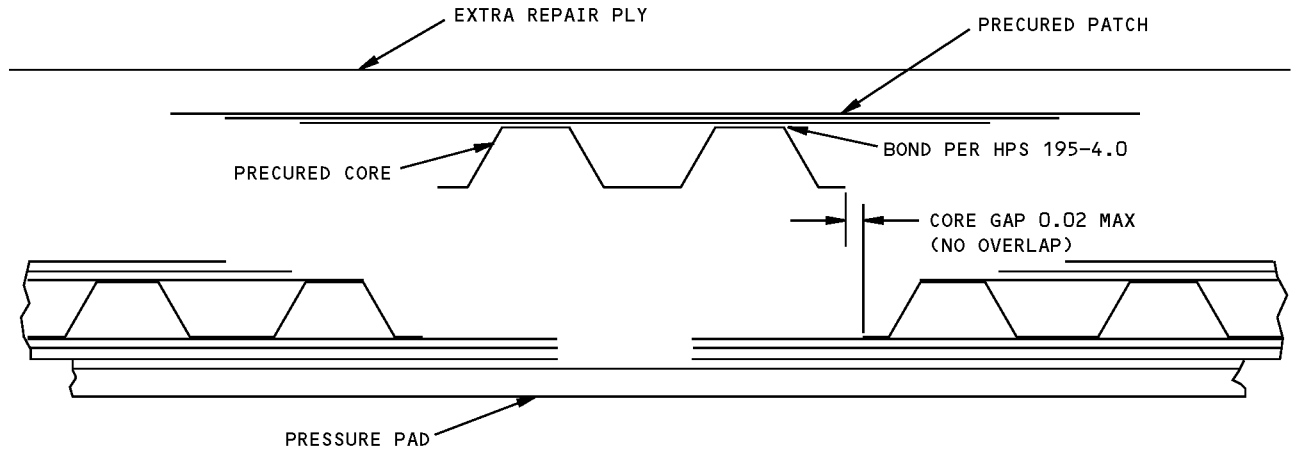
DETAIL I



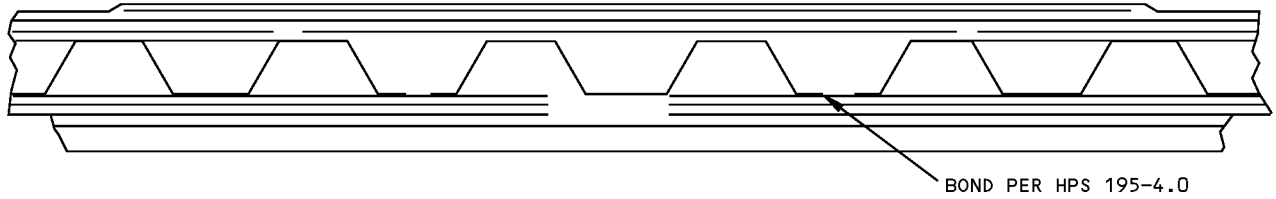
CORE GAP
DETAIL II

**Replacement of Core and One Skin
Figure 213**

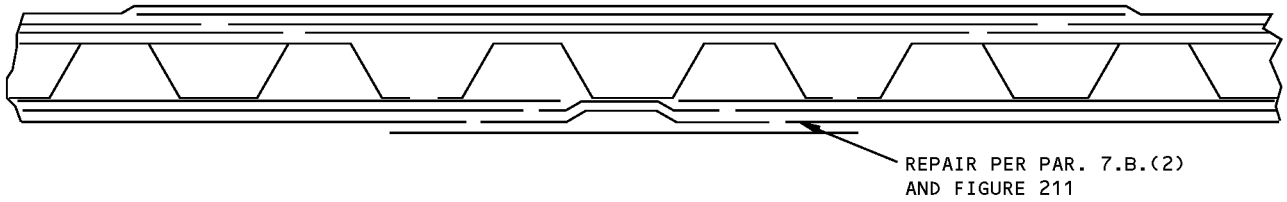
**757-200
STRUCTURAL REPAIR MANUAL**



STEP 1



STEP 2



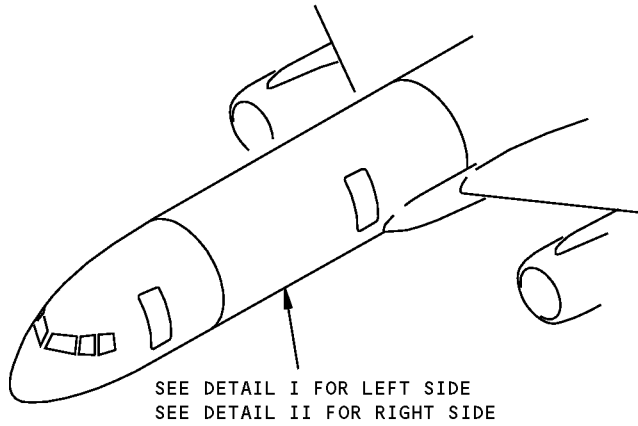
STEP 3

**Replacment of Core and Both Skins
Figure 214**



757-200
STRUCTURAL REPAIR MANUAL

IDENTIFICATION 1 - SECTION 43 - SKINS



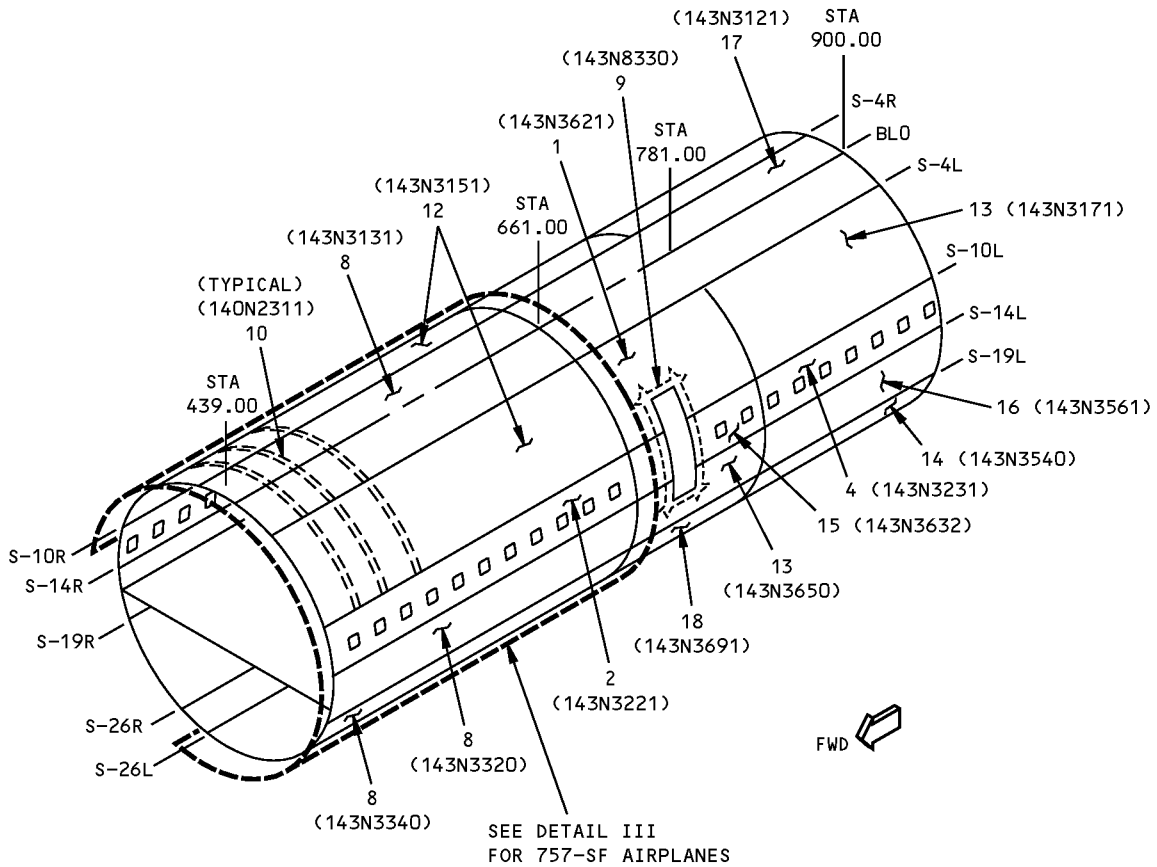
Section 43 Skin Identification
Figure 1 (Sheet 1 of 5)

D634N201

53-30-01

IDENTIFICATION 1
Page 1
Jan 20/2005

**757-200
STRUCTURAL REPAIR MANUAL**



**LEFT SIDE
DETAIL I**

LIST OF
MATL

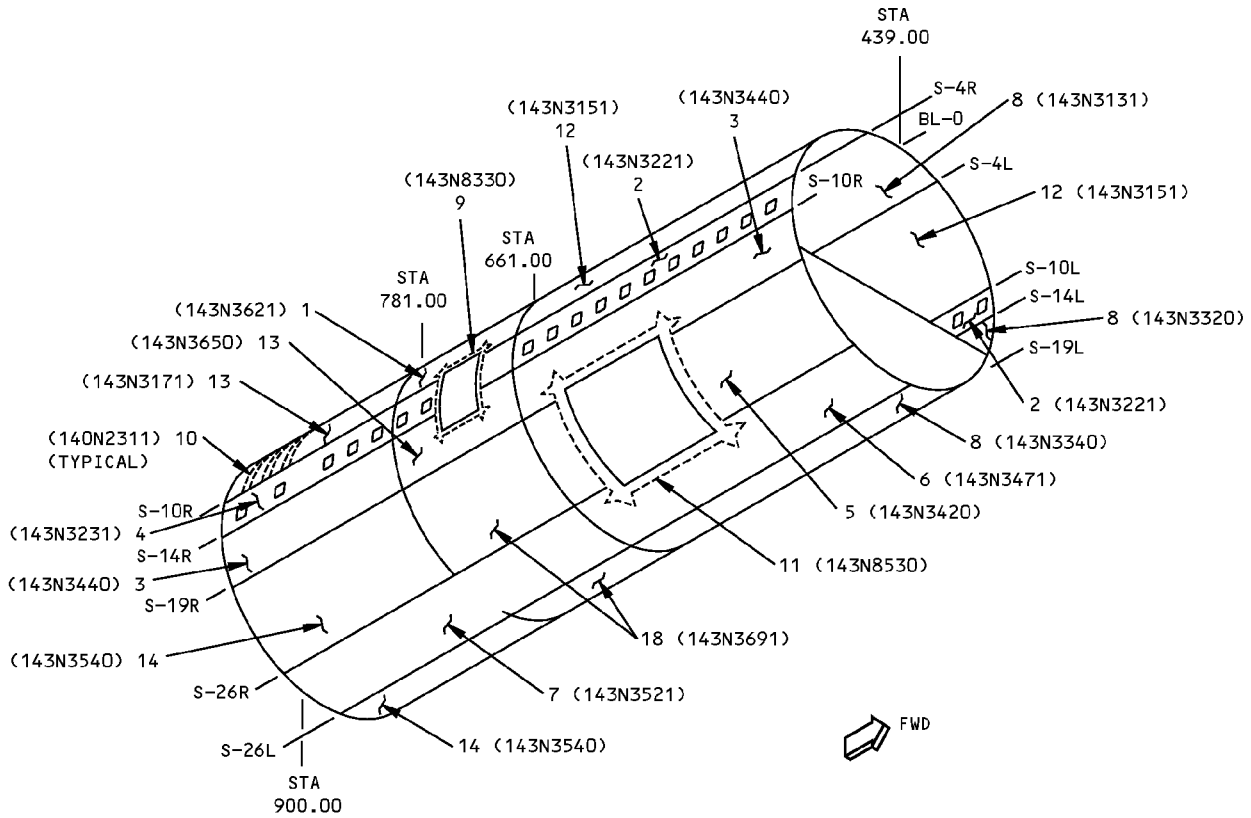
**Section 43 Skin Identification
Figure 1 (Sheet 2 of 5)**

IDENTIFICATION 1
Page 2
Jan 20/2005

53-30-01

D634N201

**757-200
STRUCTURAL REPAIR MANUAL**



**RIGHT SIDE
DETAIL II**

**Section 43 Skin Identification
Figure 1 (Sheet 3 of 5)**



757-200
STRUCTURAL REPAIR MANUAL

ITEM	DESCRIPTION	GAGE	MATERIAL	EFFECTIVITY
1	SKIN	0.125	CLAD 2024-T3 (CHEM-MILLED TO 0.045 MIN)	
2	SKIN	0.080	CLAD 2024-T3 (CHEM-MILLED TO 0.060 MIN)	
3	SKIN	0.140	CLAD 2024-T3 (CHEM-MILLED TO 0.040 MIN)	
4	SKIN	0.155	CLAD 2024-T3 (CHEM-MILLED TO 0.080 MIN)	
5	SKIN	0.090	CLAD 2024-T3 (CHEM-MILLED TO 0.040 MIN)	
6	SKIN	0.100	CLAD 2024-T3 (CHEM-MILLED TO 0.040 MIN)	
7	SKIN	0.200	CLAD 2024-T3 (CHEM-MILLED TO 0.040 MIN)	
8	SKIN	0.080	CLAD 2024-T3 (CHEM-MILLED TO 0.040 MIN)	
9	DOUBLER BEARSTRAP	0.090	2024-T3	
10	TEAR STRAP	0.063	CLAD 2024-T3	
11	DOUBLER BEARSTRAP	0.140	2024-T3	
12	SKIN	0.070	2024-T3 (CHEM-MILLED TO 0.040 MIN)	
13	SKIN	0.140	2024-T3 (CHEM-MILLED TO 0.050 MIN)	
14	SKIN	0.125	CLAD 2024-T3 (CHEM-MILLED TO 0.05 MIN)	
15	SKIN	0.125	CLAD 2024-T3 (CHEM-MILLED TO 0.080 MIN)	
16	SKIN	0.105	CLAD 2024-T3 (CHEM-MILLED TO 0.050 MIN)	
17	SKIN	0.110	CLAD 2024-T3 (CHEM-MILLED TO 0.040 MIN)	
18	SKIN	0.080 0.063	CLAD 2024-T3 (CHEM-MILLED TO 0.040 MIN)	

LIST OF MATERIALS FOR DETAILS I AND II

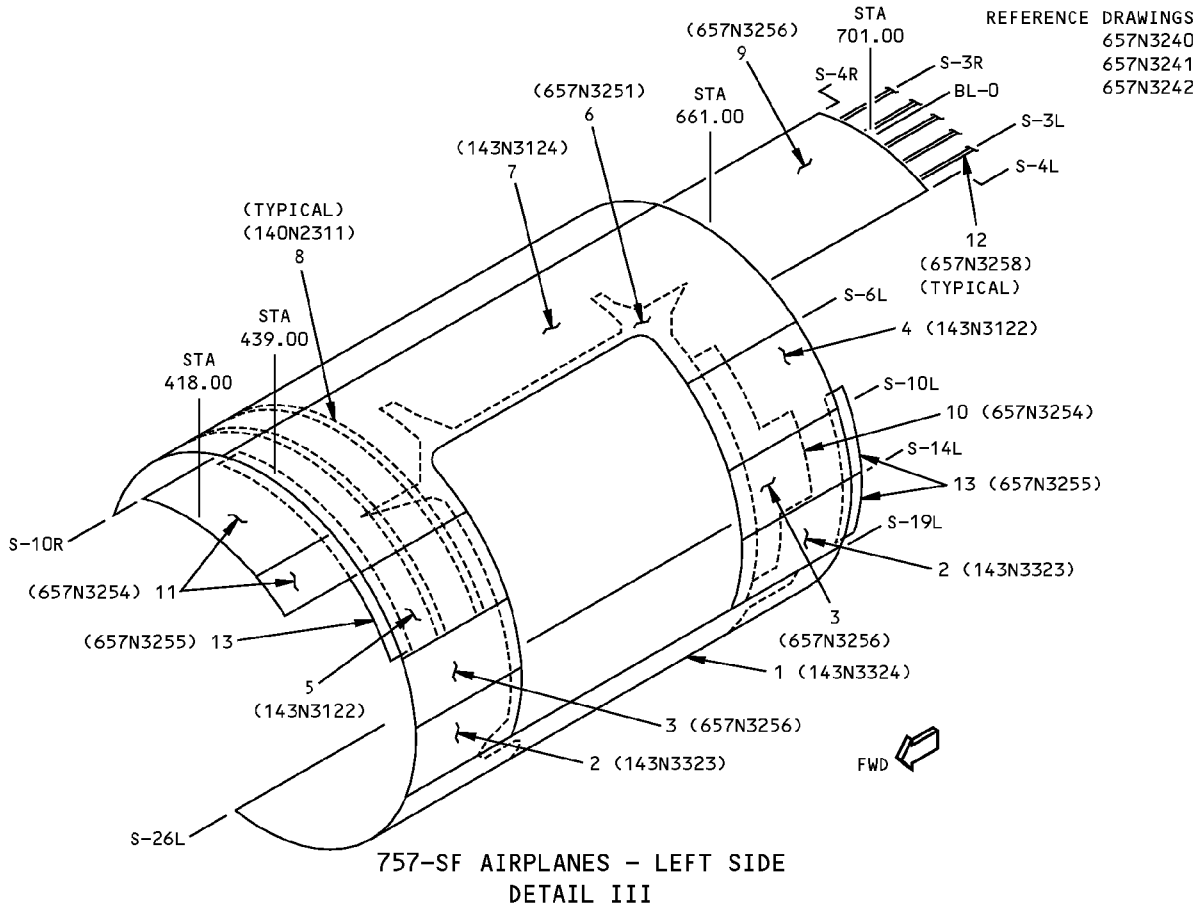
Section 43 Skin Identification
Figure 1 (Sheet 4 of 5)

D634N201

53-30-01

IDENTIFICATION 1
Page 4
Jan 20/2005

**757-200
STRUCTURAL REPAIR MANUAL**



ITEM	DESCRIPTION	GAGE	MATERIAL	EFFECTIVITY
1	SKIN	0.080	CLAD 2024-T3 (CHEM-MILLED TO 0.040 MINIMUM)	
2	SKIN	0.090	CLAD 2024-T3 (CHEM-MILLED TO 0.070 MINIMUM)	
3	SKIN	0.090	CLAD 2024-T3	
4	SKIN	0.080	CLAD 2024-T3	
5	SKIN	0.063	CLAD 2024-T3	
6	DOUBLER BEARSTRAP	0.160	2024-T3	
7	SKIN	0.100	CLAD 2024-T3 (MACHINED TO 0.080 MINIMUM)	
8	TEARSTRAP	0.063	2024-T3	
9	SKIN	0.160	CLAD 2024-T3 (MACHINED TO 0.075 MINIMUM)	
10	DOUBLER	0.160	CLAD 2024-T3	
11	SKIN	0.063	CLAD 2024-T3	
12	STRAP	0.160	7075-T73511 EXTRUSION	
13	SKIN STRAP	0.090	CLAD 2024-T3	

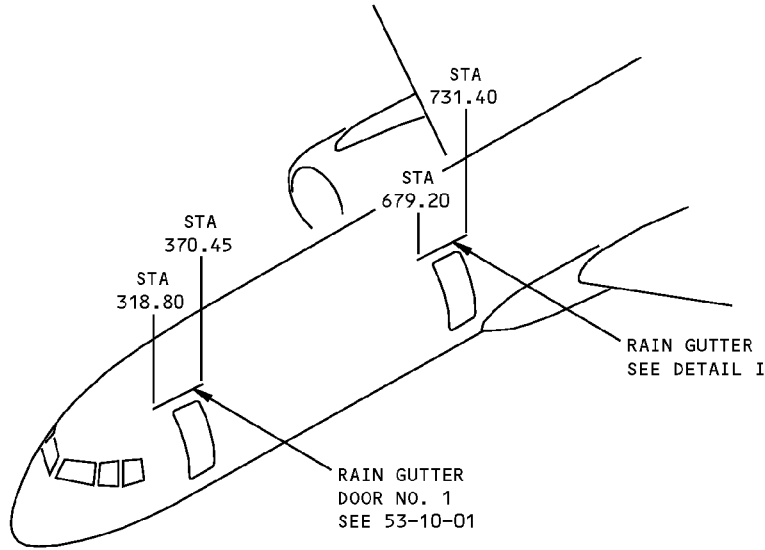
LIST OF MATERIALS FOR DETAILS III

**Section 43 Skin Identification
Figure 1 (Sheet 5 of 5)**

**757-200
STRUCTURAL REPAIR MANUAL**

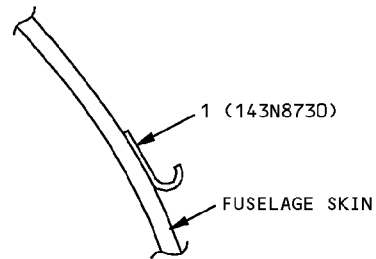
IDENTIFICATION 2 - RAIN GUTTER

REF DWG
143N3600



NOTES

- A** FOR CUM LINE NUMBERS:
1 THRU 27
- B** FOR CUM LINE NUMBERS:
28 AND ON



SECTION THRU RAIN GUTTER
DETAIL I

ITEM	DESCRIPTION	GAGE	MATERIAL	EFFECTIVITY		
1	GUTTER		BAC1498-356 CLAD 7075-T6 BAC1498-356 CLAD 2024-T3	<table border="1"> <tr><td align="center">A</td></tr> <tr><td align="center">B</td></tr> </table>	A	B
A						
B						

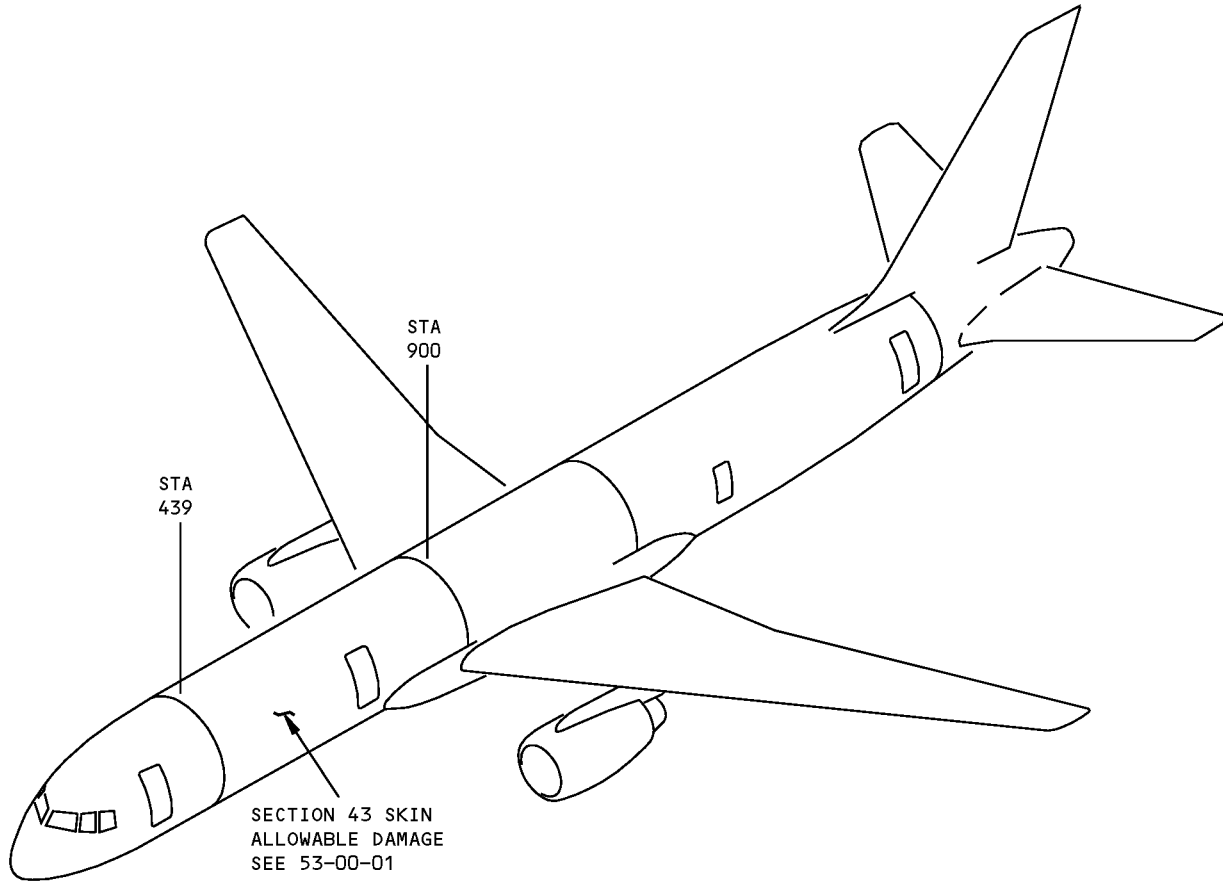
LIST OF MATERIALS FOR DETAIL I

**Rain Gutter Identification
Figure 1**



757-200
STRUCTURAL REPAIR MANUAL

ALLOWABLE DAMAGE 1 - SECTION 43 - SKINS



Section 43 Skin Allowable Damage
Figure 101

D634N201

ALLOWABLE DAMAGE 1
Page 101
53-30-01
Jan 20/2005



**757-200
STRUCTURAL REPAIR MANUAL**

REPAIR GENERAL - SERVICE BULLETIN REPAIR CHART

SERVICE BULLETIN REPAIRS

The following service bulletins contain Section 43 Skin repairs which are available for use where specific damage has been encountered. Usually, the service bulletin also covers preventive modification data which operators are encouraged to use to eliminate the need for repair.

DAMAGED AREA	CUM LINE NUMBER EFFECTIVITY <input type="checkbox"/> A	SB NUMBER
FUSELAGE - SKIN AND STIFFENERS LOWER VHF ANTENNA MOUNT, BS 730, BL 0.0	1 THRU 268	757-53A0052

A FOR AIRPLANES ON WHICH PREVENTIVE MODIFICATION HAS NOT BEEN ACCOMPLISHED

**Service Bulletin Repair Chart
Figure 201**

D634N201

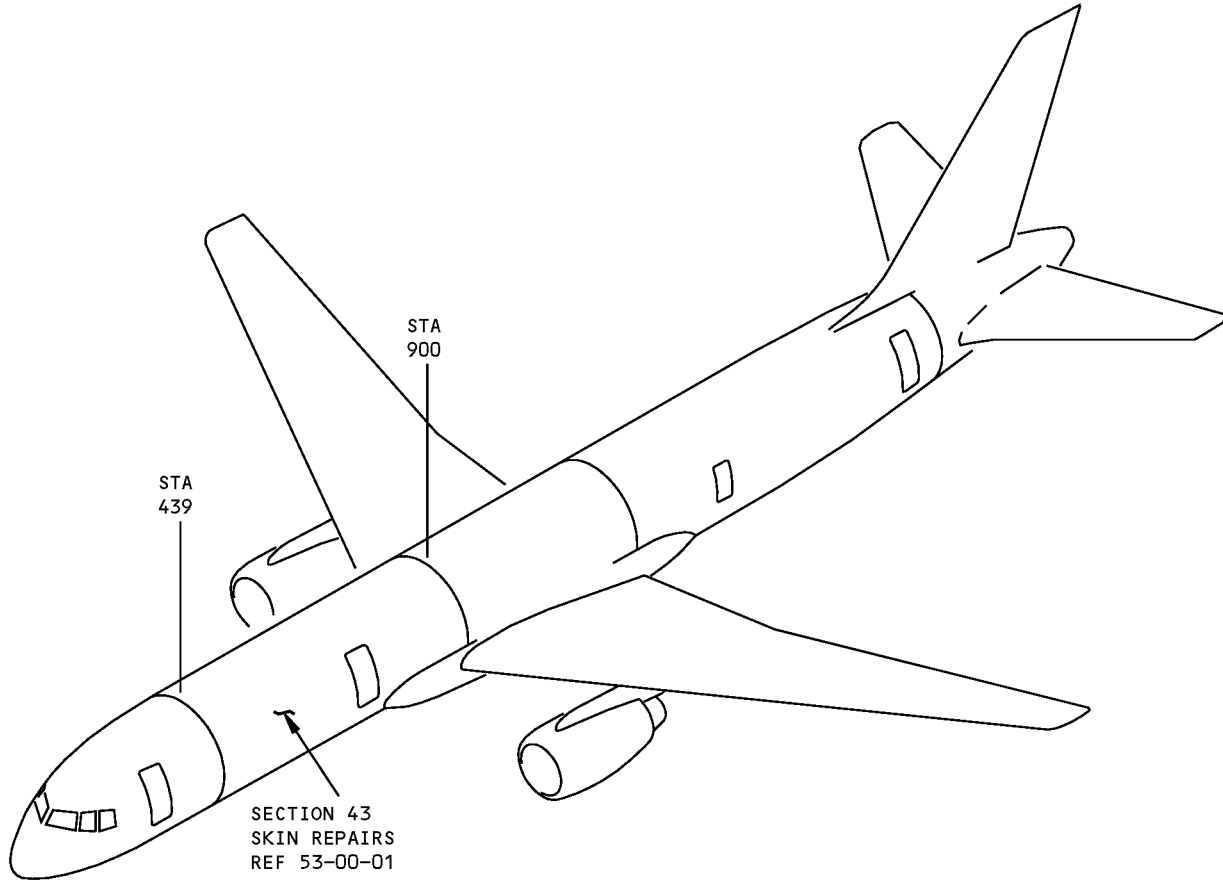
53-30-01

REPAIR GENERAL
Page 201
Jan 20/2005



757-200
STRUCTURAL REPAIR MANUAL

REPAIR 1 - SECTION 43 - SKINS



Section 43 Skin Repairs
Figure 201

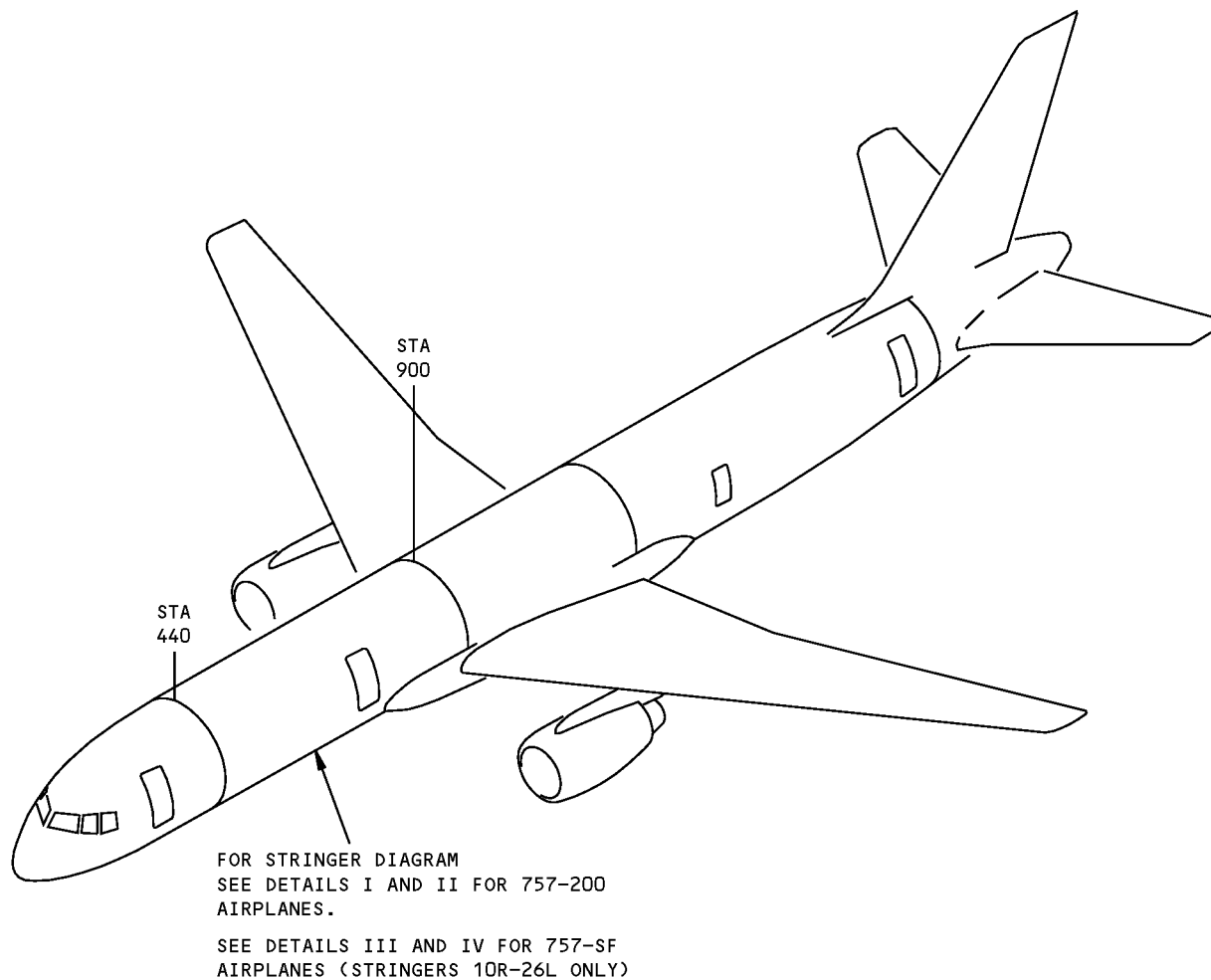
D634N201

53-30-01

REPAIR 1
Page 201
Jan 20/2006

757-200
STRUCTURAL REPAIR MANUAL

IDENTIFICATION 1 - SECTION 43 - STRINGERS

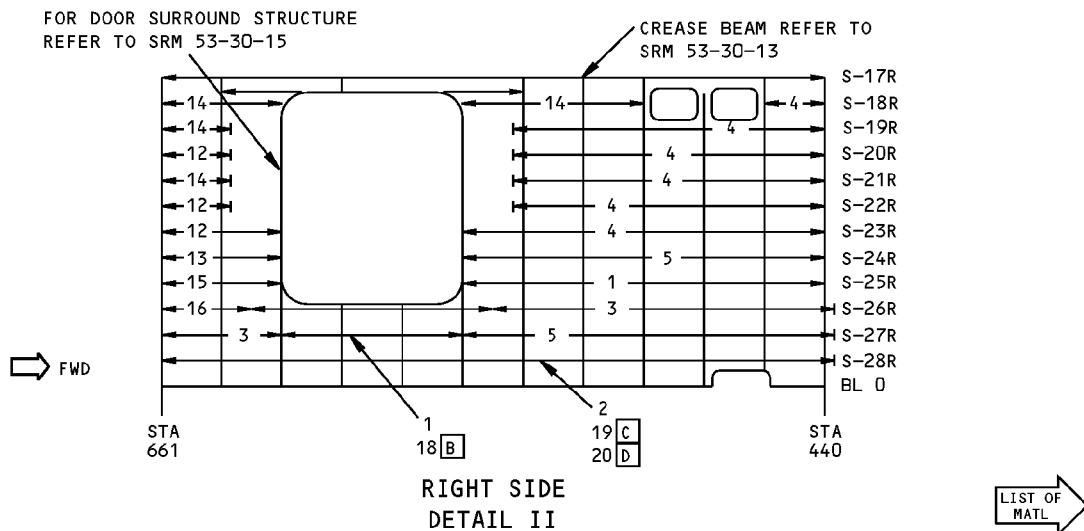
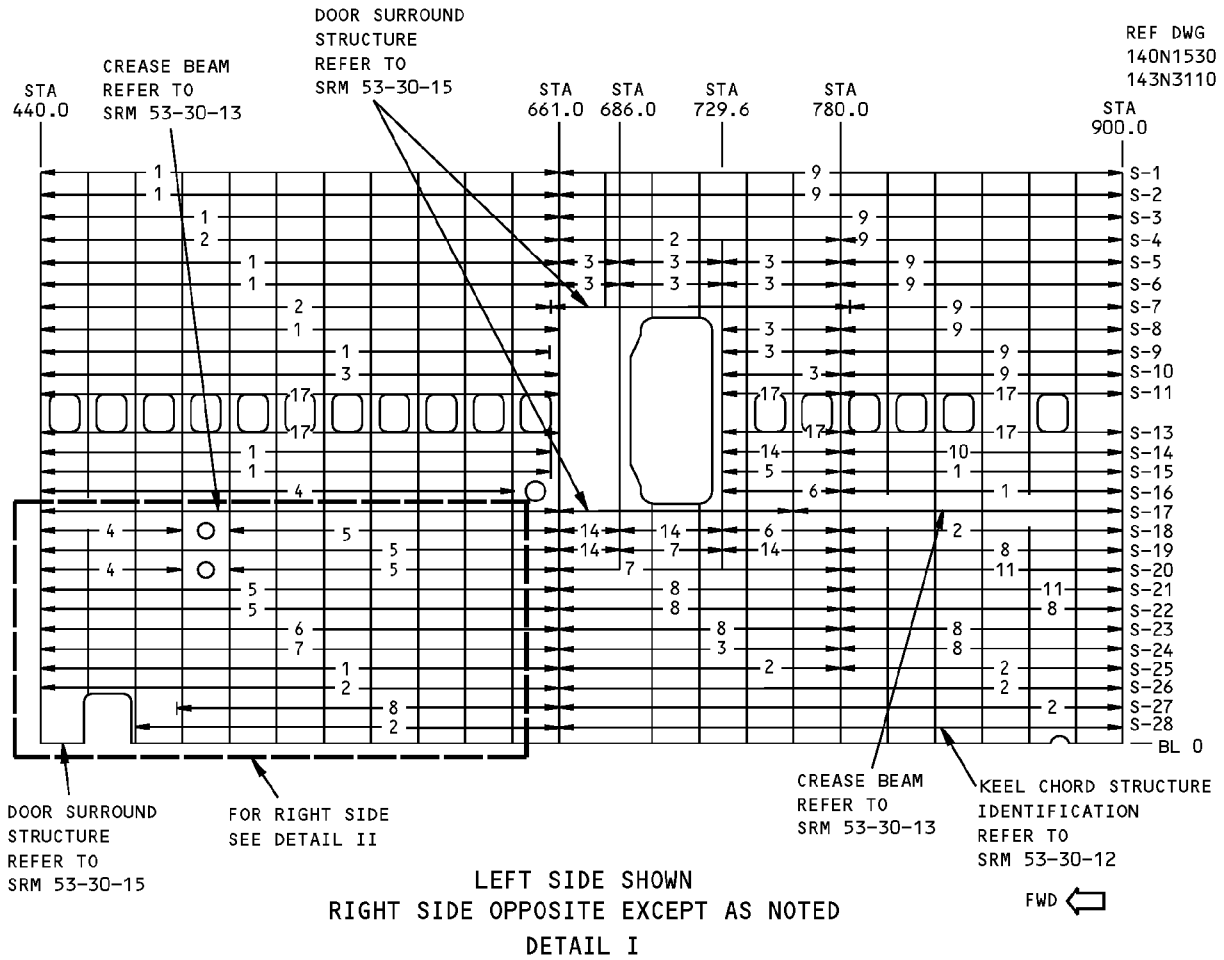


NOTES

- A** GAGES VARY THROUGHOUT THE LENGTH OF THE STRINGER. MAXIMUM GAGES ARE SHOWN.
- B** FOR CUM LINE NUMBERS 209 AND ON
- C** FOR CUM LINE NUMBERS 232 AND ON
- D** FOR AIRPLANES WITH CUM LINE NUMBERS 210 THRU 231 BETWEEN BS 509 AND 610

Section 43 Stringer Identification
Figure 1 (Sheet 1 of 4)

**757-200
STRUCTURAL REPAIR MANUAL**



**Section 43 Stringer Identification
Figure 1 (Sheet 2 of 4)**



**757-200
STRUCTURAL REPAIR MANUAL**

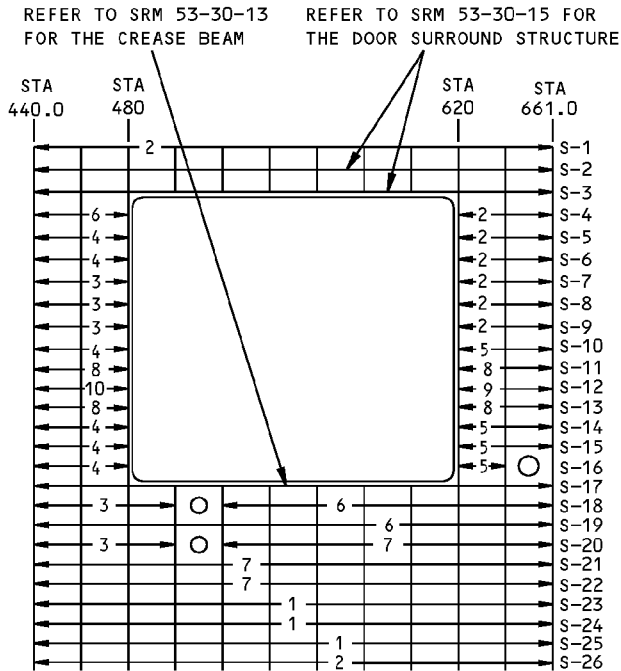
ITEM	DESCRIPTION	GAGE	MATERIAL	STRINGER TYPE	REF DWG	EFFECTIVITY
1	STRINGER	0.063 [A]	7075-T6		143N3110	
2	STRINGER	0.090 [A]	7075-T6		143N3110	
3	STRINGER	0.080 [A]	7075-T6		143N3110	
4	STRINGER	0.032	7075-T6		143N3110	
5	STRINGER	0.040 [A]	7075-T6		143N3110	
6	STRINGER	0.045 [A]	7075-T6		143N3110	
7	STRINGER	0.050 [A]	7075-T6		143N3110	
8	STRINGER	0.071 [A]	7075-T6		143N3110	
9	STRINGER	0.100 [A]	7075-T6		143N3110	
10	STRINGER	0.056 [A]	7075-T6		143N3110	
11	STRINGER	0.050	7075-T6		143N3110	
12	STRINGER	0.045	7075-T6		143N3110	
13	STRINGER	0.056	7075-T6		143N3110	
14	STRINGER	0.040	7075-T6		143N3110	
15	STRINGER	0.060	7075-T6		143N3110	
16	STRINGER	0.063	7075-T6		143N3110	
17	STRINGER	0.063	BAC1517-1471 7075-T6511		143N3210	
18	STRINGER	0.050	BAC1498-209 7075-T6		143N3110	[B]
19	STRINGER	0.090	BAC1498-210 7075-T6		143N3110	[C]
20	STRINGER ASSY	0.050	7075-T6		143N3110	[D]
	STRINGER	0.050	7075-T6		143N3407	
	J SECTION	0.090	7075-T73		143N3400	
	STRAP					

LIST OF MATERIALS FOR DETAILS I AND II

**Section 43 Stringer Identification
Figure 1 (Sheet 3 of 4)**

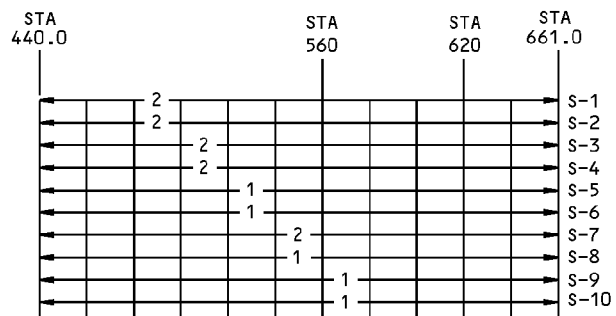
757-200 STRUCTURAL REPAIR MANUAL

REFERENCE DRAWINGS
657N3240
657N3241
657N3242



FWD ←

LEFT SIDE
DETAIL III



RIGHT SIDE
DETAIL IV

ITEM	DESCRIPTION	GAGE A	MATERIAL	STRINGER TYPE	REF DWG	EFFECTIVITY
1	STRINGER	0.063	7075-T6		143N3110	
2	STRINGER	0.090	7075-T6		143N3110	
3	STRINGER	0.032	7075-T6		143N3110	
4	STRINGER	0.040	7075-T6		143N3110	
5	STRINGER	0.045	7075-T6		143N3110	
6	STRINGER	0.071	7075-T6		143N3110	
7	STRINGER	0.056	7075-T6		143N3110	
8	STRINGER		BAC1517-1471 7075-T6511		143N3210	
9	STRINGER	0.063	BAC1498-209 7075-T6		143N3110	
10	STRINGER	0.045	BAC1498-207 7075-T6		143N3110	

LIST OF MATERIALS FOR DETAILS III AND IV

**Section 43 Stringer Identification
Figure 1 (Sheet 4 of 4)**

IDENTIFICATION 1
Page 4
Jan 20/2005

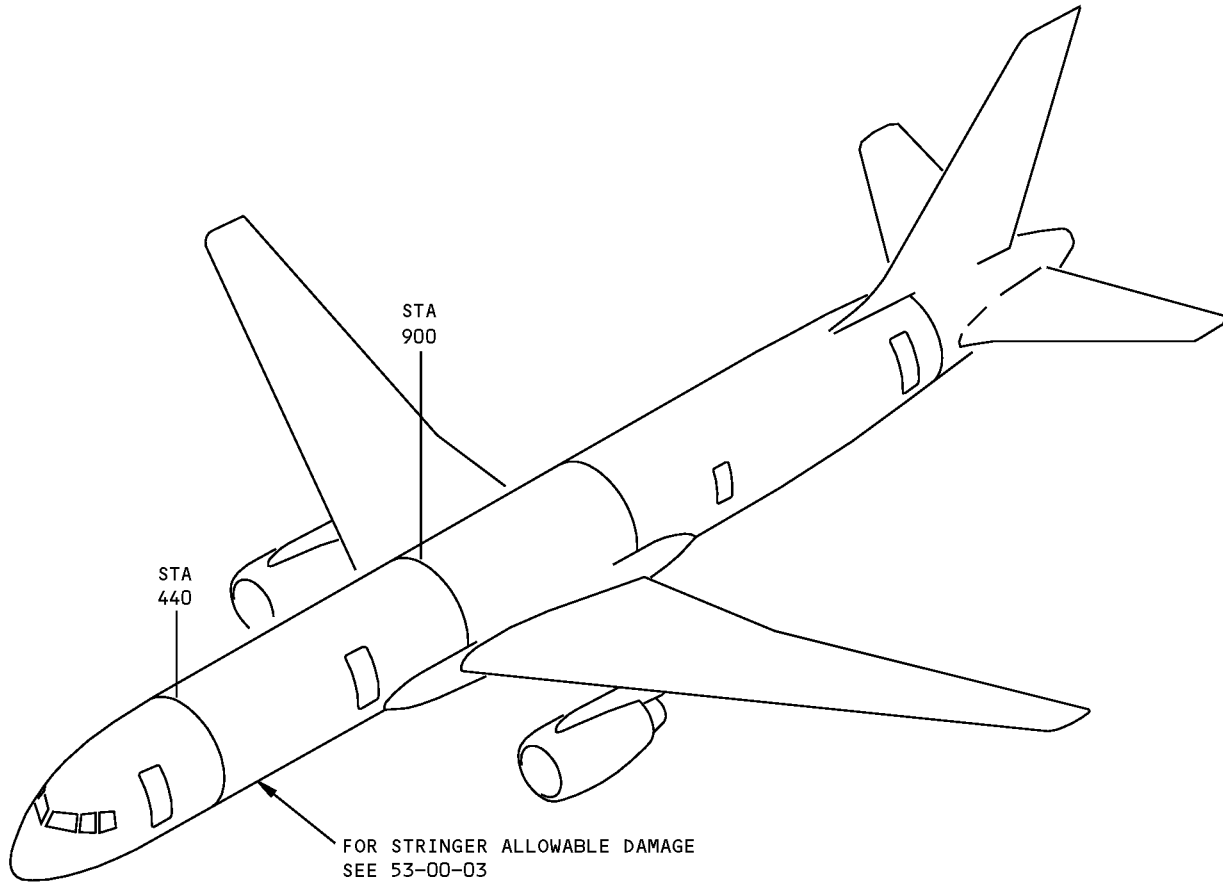
53-30-03

D634N201



757-200
STRUCTURAL REPAIR MANUAL

ALLOWABLE DAMAGE GENERAL - SECTION 43 - STRINGERS



Section 43 Stringer Allowable Damage
Figure 101

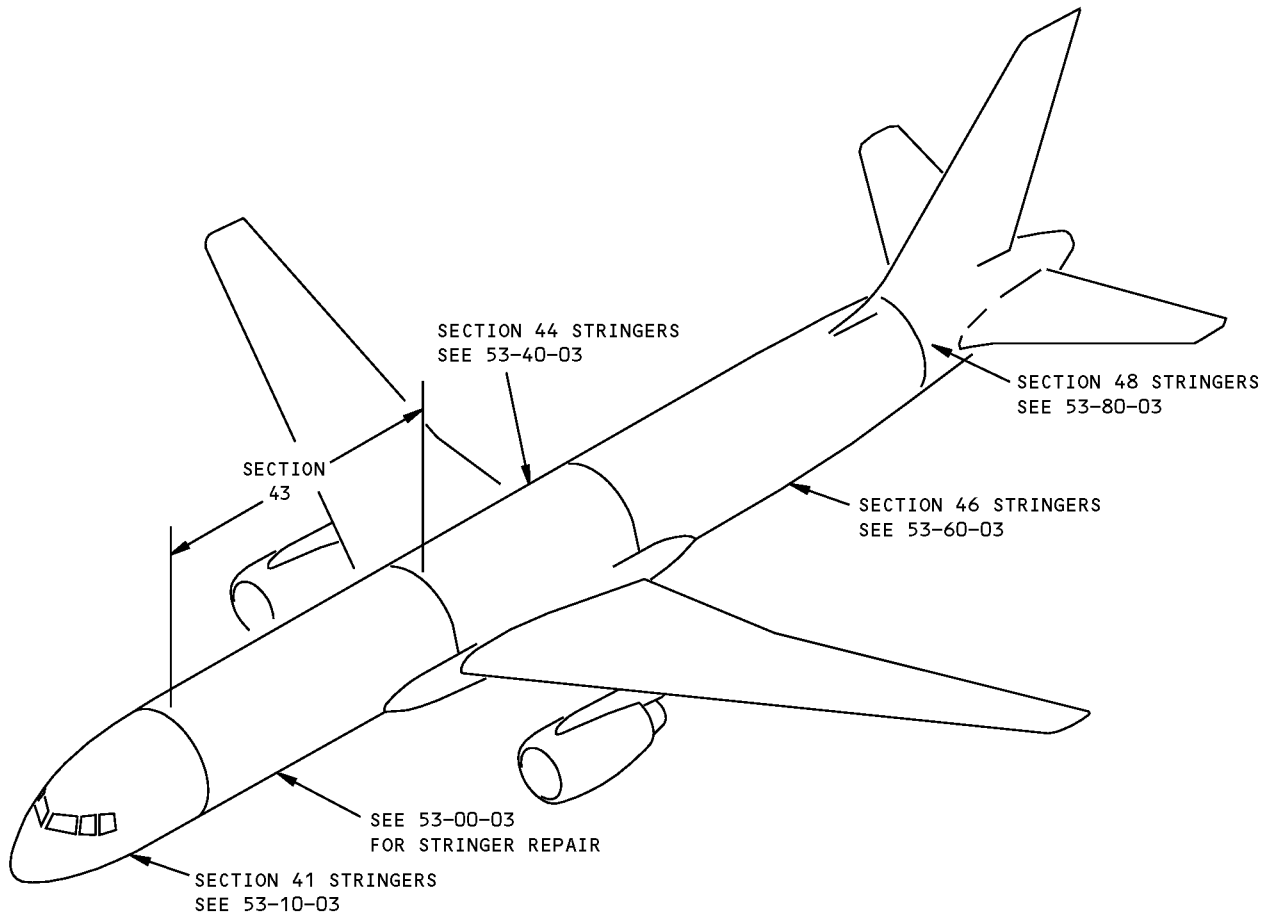
D634N201

ALLOWABLE DAMAGE GENERAL
53-30-03
Page 101
Jan 20/2007



757-200
STRUCTURAL REPAIR MANUAL

REPAIR GENERAL - SECTION 43 - STRINGERS



Section 43 Stringer Repair
Figure 201

D634N201

53-30-03

REPAIR GENERAL
Page 201
Jan 20/2005

STRUCTURAL REPAIR MANUAL

REPAIR 1 - SECTION 43 - STRINGER S-16 AT THE WING SCANNING LIGHT

APPLICABILITY
THIS REPAIR APPLIES TO CRACKS IN STRINGERS S-16R AND S-16L BETWEEN BS 640 AND BS 645. THIS LOCATION IS IMMEDIATELY FORWARD OF THE WING SCANNING LIGHT.

REPAIR INSTRUCTIONS

PART 1 - MAKE AN INSPECTION OF THE STRINGER

1. Get access to the left and right stringer (S-16L and S-16R) between BS 640 and BS 645.
2. Make a visual inspection of the stringers for cracks. Refer to SRM 51-10-02.
 - A. If there are cracks in the shaded area shown in Detail I, then repair the stringer as given in Part 2.
 - B. If a crack goes outside of the shaded area shown in Detail I, then:
 - (1) Cut and remove the aft part of the stringer at BS 630.
 - (2) Repair the stringer from BS 630 to BS 645 as given in SRM 53-00-03, Figure 201.
 - (3) Do the modification given in Service Bulletin 757-53-0016.

PART 2 - REPAIR THE STRINGER

1. Cut and remove the damaged part of the stringer.
 - A. You must remove a minimum of the structure as shown in Detail II.
 - B. Cut and remove any damaged part of the stringer that remains. Remove the material only in the shaded area shown in Detail I. Cut out only the structure that is cracked.
 - C. Do a high frequency eddy current inspection (HFEC) on the cut edge of the stringer. If there are no cracks, remove 1/32 inch more from the cut edge of the stringer. Refer to SRM 51-10-02. Refer to NDT Part 6, 51-00-01, or 51-00-19 for the HFEC procedure.
2. Make the repair parts. See Table I.
3. Assemble the repair parts and drill the fastener holes. See Detail III.
4. Disassemble the repair parts.
5. Remove the nicks, scratches, burrs, sharp edges and corners from the initial parts and the repair parts.
6. Apply a chemical conversion coating to the repair parts and the cut edges of the initial parts. Refer to SRM 51-20-01.

7. Apply two layers of BMS 10-11, Type I primer to the repair parts and to the bare surfaces of the initial structure. Refer to SOPM 20-41-02.
8. Install the repair parts with BMS 5-95 sealant between mating surfaces.
9. Apply a finish to the repair area. Refer to AMM 20-44-04.

NOTES

- THIS IS A CATEGORY A REPAIR FOR 757-200 AND 757-SF AIRPLANES. THE INSPECTIONS GIVEN IN THE MAINTENANCE PLANNING DATA (MPD) ARE SUFFICIENT TO MAINTAIN THE DAMAGE TOLERANCE OF THE INITIAL STRUCTURE WITH THIS REPAIR INSTALLED. REFER TO SRM 51-00-06 FOR REPAIR CATEGORIES AND DEFINITIONS.
- WHEN YOU USE THIS REPAIR REFER TO:
 - NDT PART 6, 51-00-01 FOR THE HIGH FREQUENCY EDDY CURRENT INSPECTION PROCEDURES
 - SOPM 20-41-02 FOR APPLICATION OF FINISHES
 - SRM 51-10-02 FOR INSPECTION AND REMOVAL OF DAMAGE
 - SRM 51-20-01 FOR PROTECTIVE TREATMENT OF METALLIC AND GRAPHITE MATERIALS
 - SRM 51-20-05 FOR REPAIR SEALING
 - SRM 51-40 FOR FASTENER CODE, INSTALLATION AND REMOVAL, SUBSTITUTIONS, HOLE SIZES, AND EDGE MARGINS.

FASTENER SYMBOLS

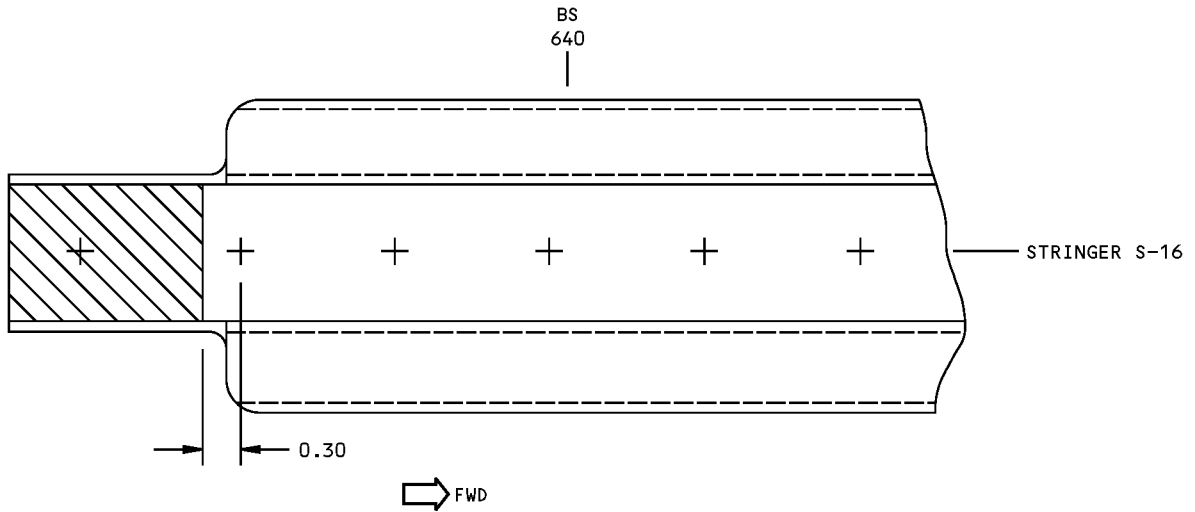
- + INITIAL FASTENER LOCATION. INSTALL A FASTENER THAT IS THE SAME DIMENSIONS AND TYPE AS THE INITIAL FASTENER.
- ◆ REPAIR FASTENER LOCATION. INSTALL A BACB30VT6K HEX DRIVE FASTENER.
- ⊕ INITIAL FASTENER LOCATIONS. INSTALL A BACB30NW6K()Y HEX DRIVE FASTENER THAT IS 1/32 INCH DIAMETER OVERSIZE.

**Stringer Repair - Stringer S-16 at the Wing Scanning Light
Figure 201 (Sheet 1 of 5)**

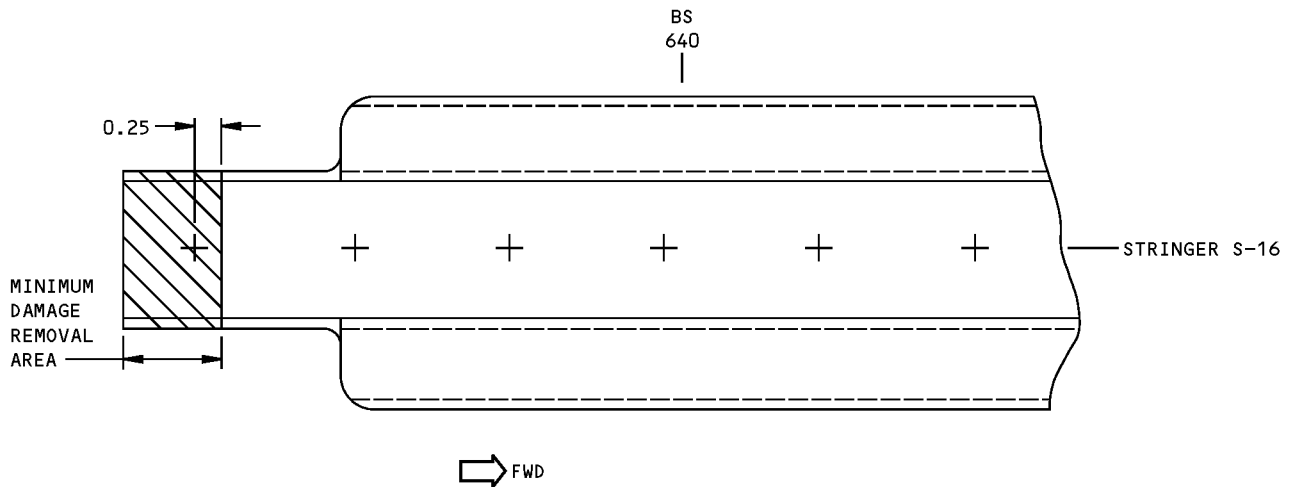
**757-200
STRUCTURAL REPAIR MANUAL**

REPAIR MATERIAL			
	PART	QTY	MATERIAL
1	CHANNEL	1	0.040 7075-T6
2	RADIUS FILLER	1	USE 7075-T6 SHEET THAT IS BETWEEN 0.080 AND 0.100 INCH IN THICKNESS
3	SHIM	1	USE 7075-T6 SHEET THAT IS THE SAME THICKNESS AS THE INITIAL STRINGER

TABLE I



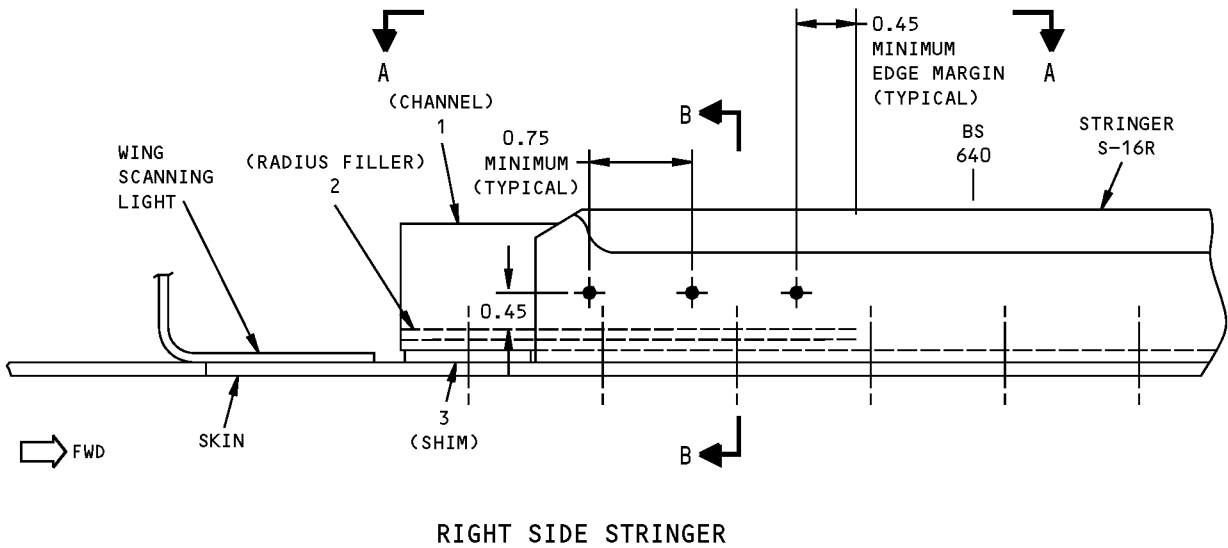
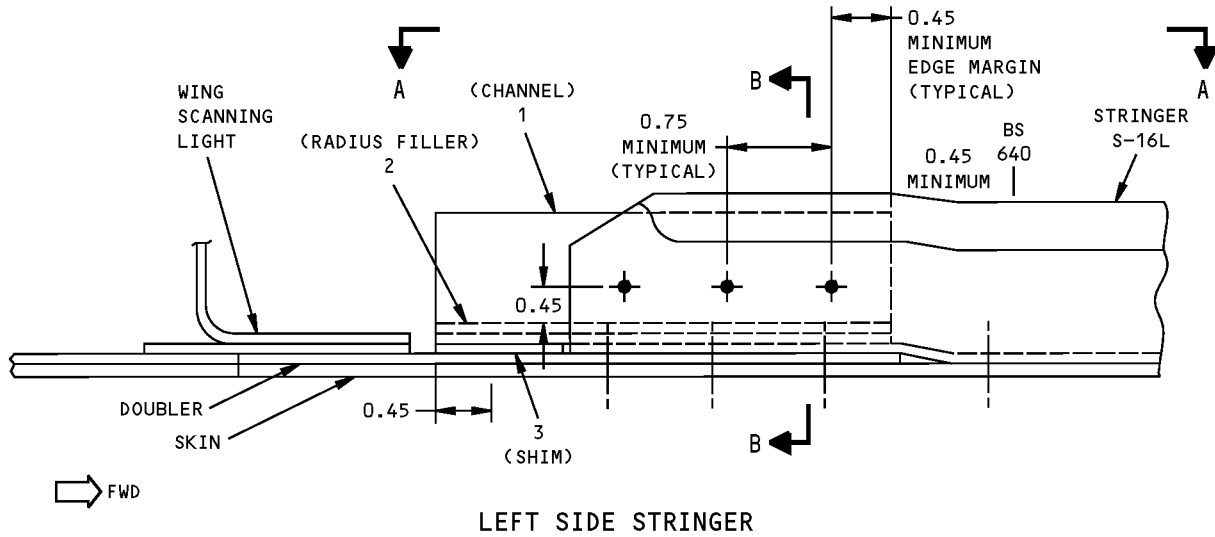
DETAIL I



DETAIL II

**Stringer Repair - Stringer S-16 at the Wing Scanning Light
Figure 201 (Sheet 2 of 5)**

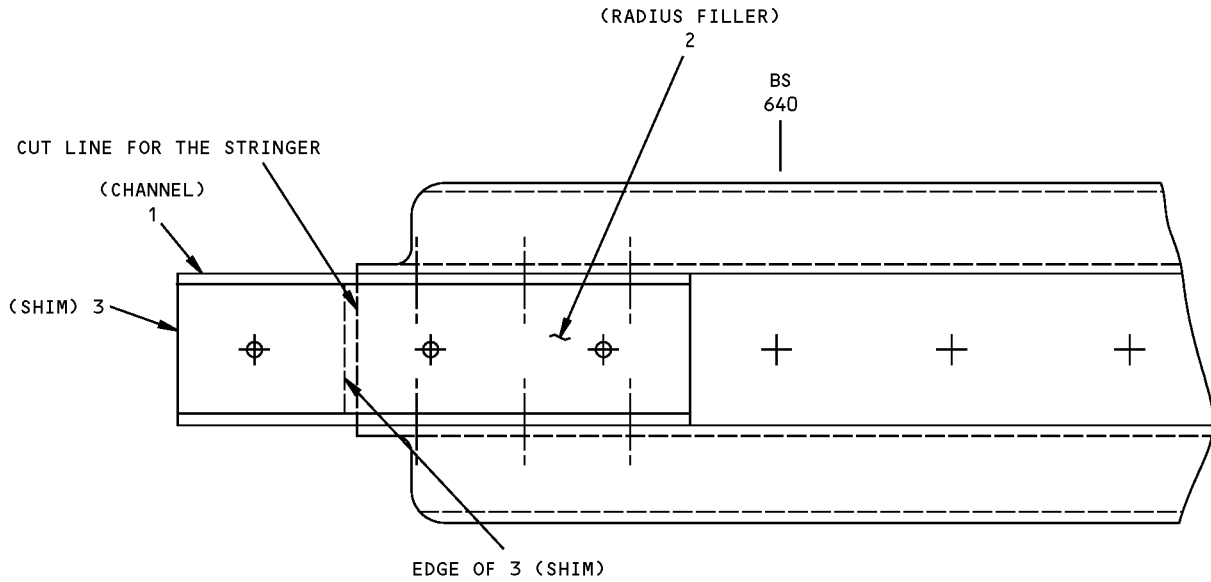
**757-200
STRUCTURAL REPAIR MANUAL**



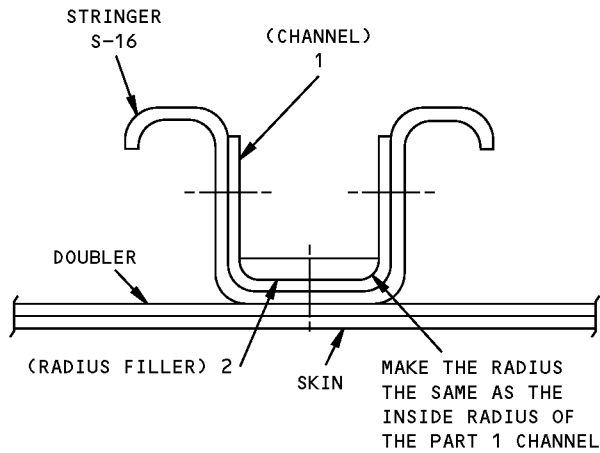
DETAIL III

**Stringer Repair - Stringer S-16 at the Wing Scanning Light
Figure 201 (Sheet 3 of 5)**

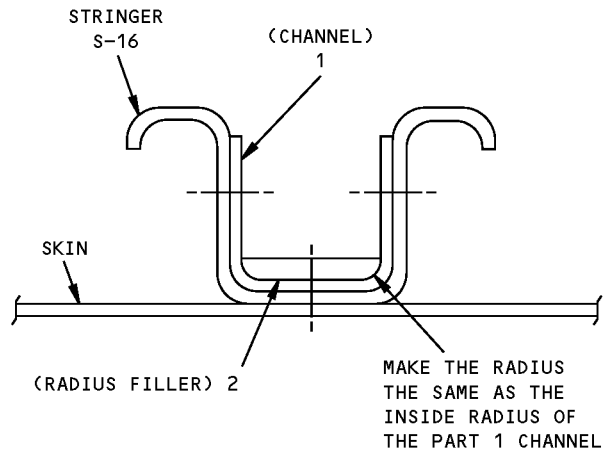
**757-200
STRUCTURAL REPAIR MANUAL**



VIEW A-A



LEFT SIDE STRINGER

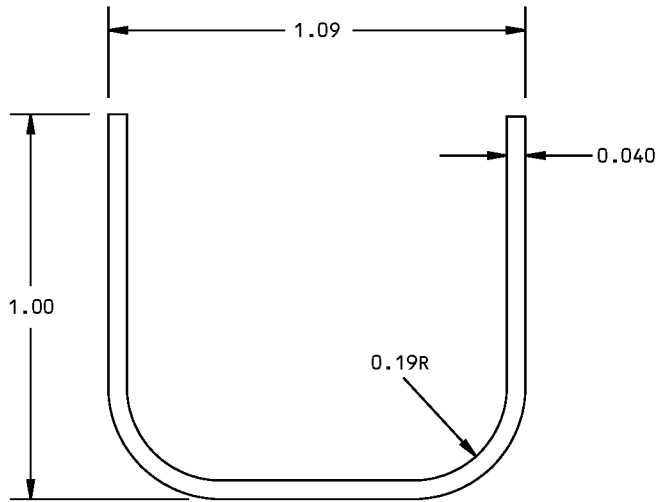


RIGHT SIDE STRINGER

SECTION B-B

**Stringer Repair - Stringer S-16 at the Wing Scanning Light
Figure 201 (Sheet 4 of 5)**

757-200
STRUCTURAL REPAIR MANUAL

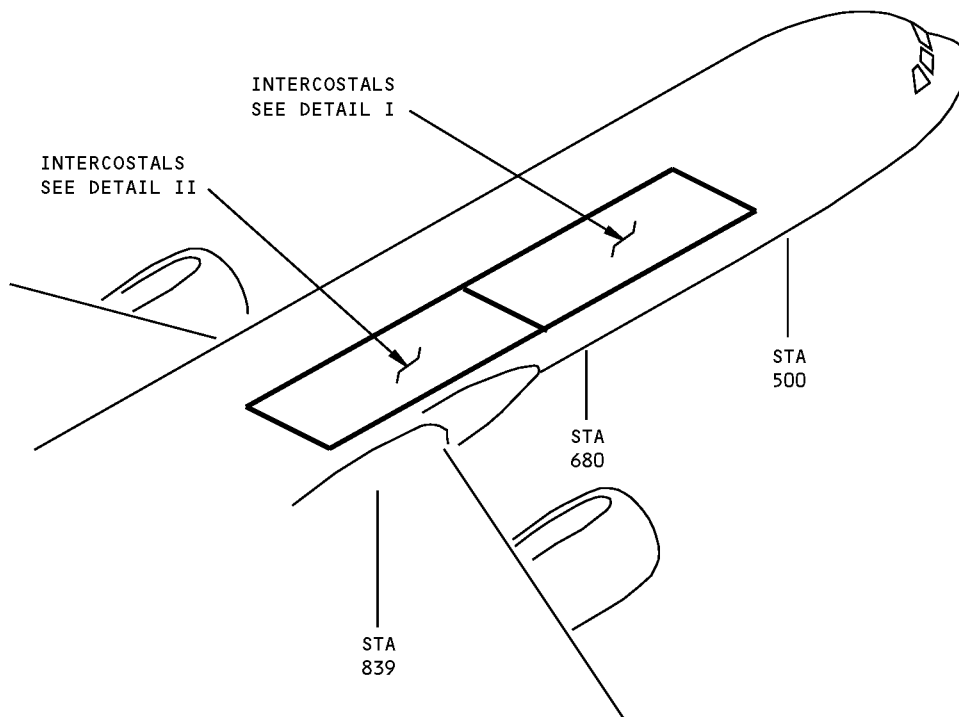


PART 1 CHANNEL
DETAIL IV

Stringer Repair - Stringer S-16 at the Wing Scanning Light
Figure 201 (Sheet 5 of 5)

**757-200
STRUCTURAL REPAIR MANUAL**

IDENTIFICATION 1 - SECTION 43 - INTERCOSTALS



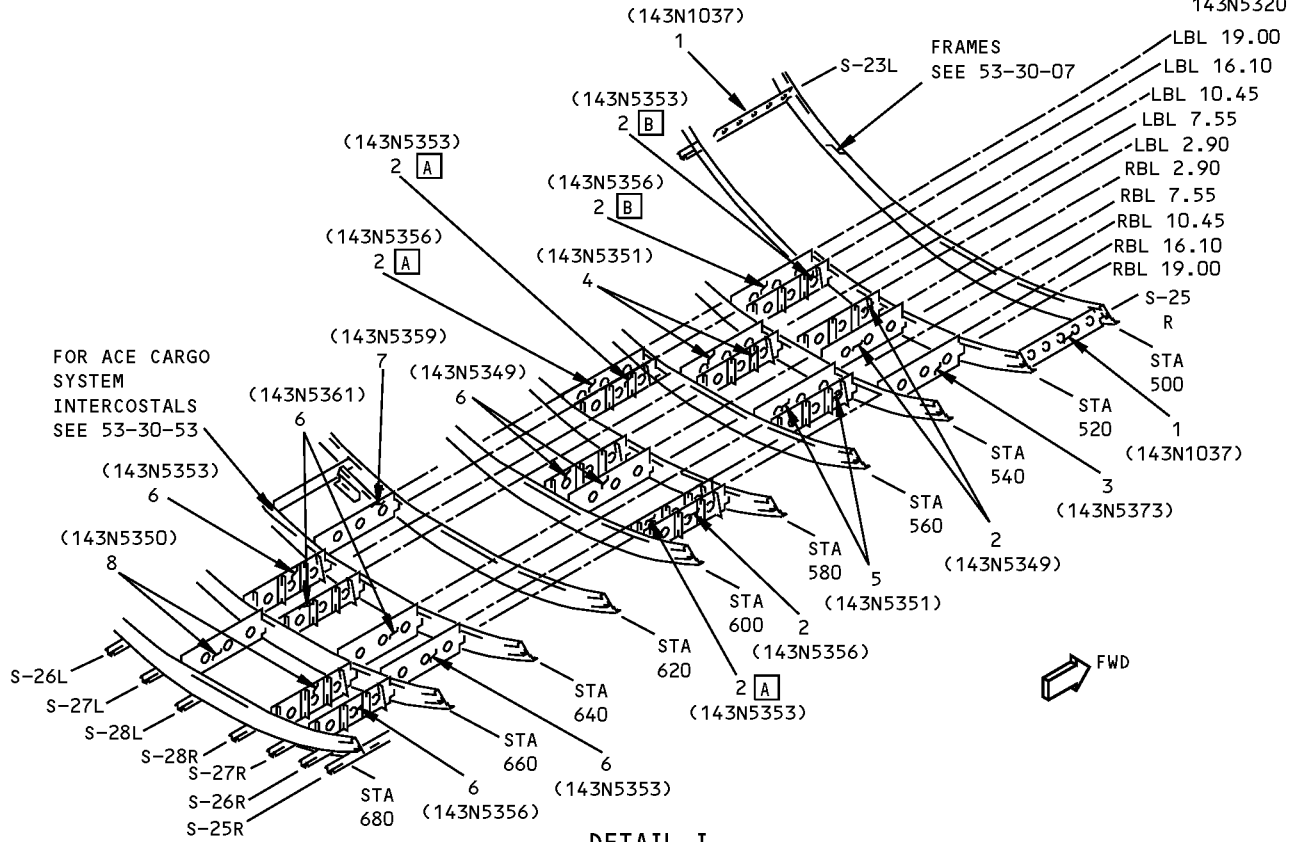
NOTES

- A** FOR CUM LINE NUMBERS:
1 THRU 5
- B** FOR CUM LINE NUMBERS:
2 THRU 5

**Section 43 Intercostal Identification
Figure 1 (Sheet 1 of 3)**

757-200 STRUCTURAL REPAIR MANUAL

REF DWG
143N5320



ITEM	DESCRIPTION	GAGE	MATERIAL	EFFECTIVITY
1	INTERCOSTAL	0.045	CLAD 7075-T6	
2	INTERCOSTAL WEB CHORD	0.04	CLAD 7075-T6	
		0.05	CLAD 7075-T6	
3	INTERCOSTAL WEB	0.04	CLAD 7075-T6	
4	INTERCOSTAL WEB CHORD	0.04	CLAD 7075-T6	
		0.063	CLAD 7075-T6	
5	INTERCOSTAL WEB CHORD	0.04	CLAD 7075-T6	
		0.056	CLAD 7075-T6	
6	INTERCOSTAL	0.032	CLAD 7075-T6	
7	INTERCOSTAL WEB CHORD	0.036	CLAD 7075-T6	
		0.063	CLAD 7075-T6	
8	INTERCOSTAL	0.04	CLAD 7075-T6	

LIST OF MATERIALS FOR DETAIL I

**Section 43 Intercostal Identification
Figure 1 (Sheet 2 of 3)**

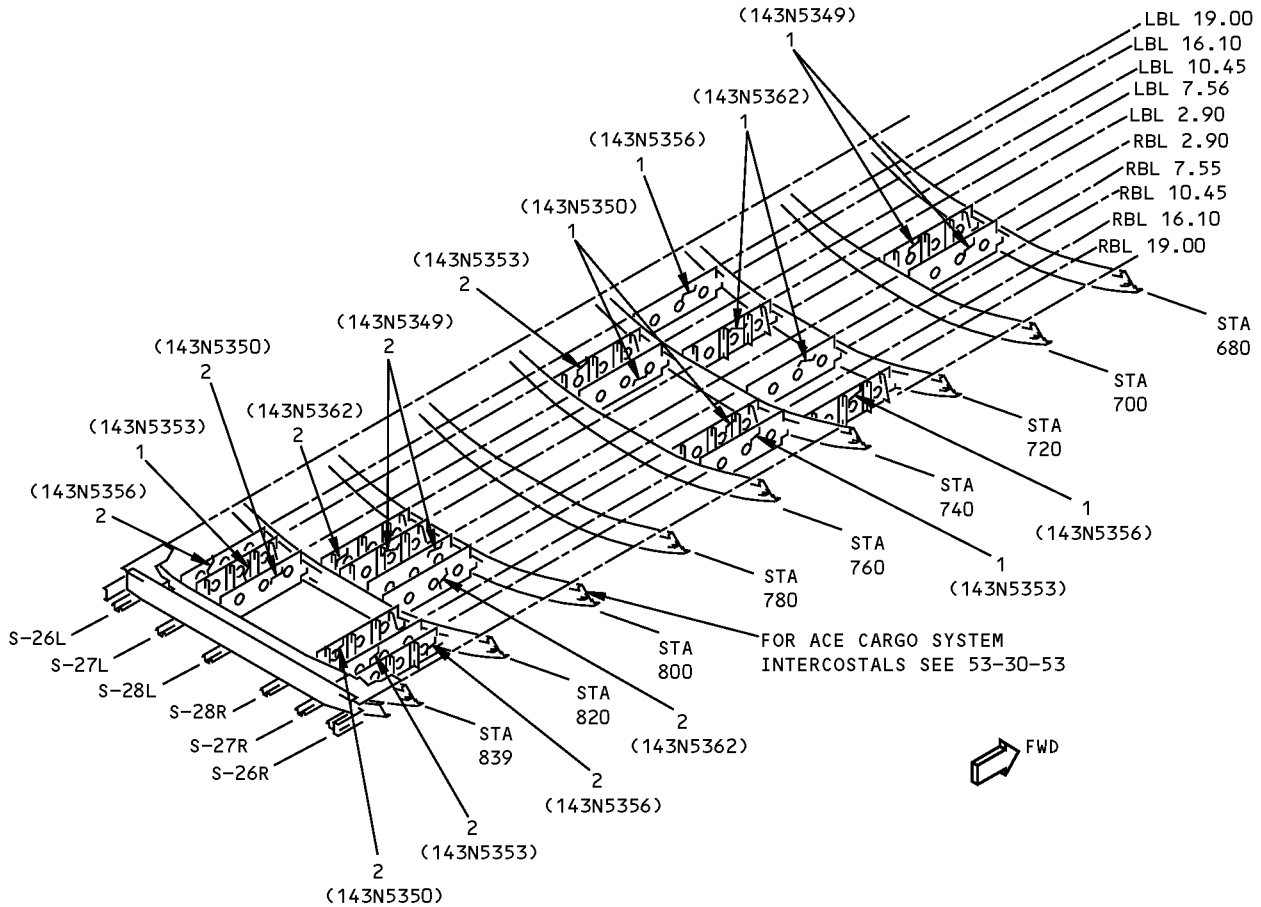
IDENTIFICATION 1
Page 2
Jan 20/2005

53-30-04

D634N201

**757-200
STRUCTURAL REPAIR MANUAL**

REF DWG
143N5320



DETAIL II

ITEM	DESCRIPTION	GAGE	MATERIAL	EFFECTIVITY
1	INTERCOSTAL	0.032		
2	INTERCOSTAL WEB CHORD	0.04 0.05	CLAD 7075-T6 CLAD 7075-T6	

LIST OF MATERIALS FOR DETAIL II

**Section 43 Intercostal Identification
Figure 1 (Sheet 3 of 3)**

IDENTIFICATION 1
Page 3
Jan 20/2005

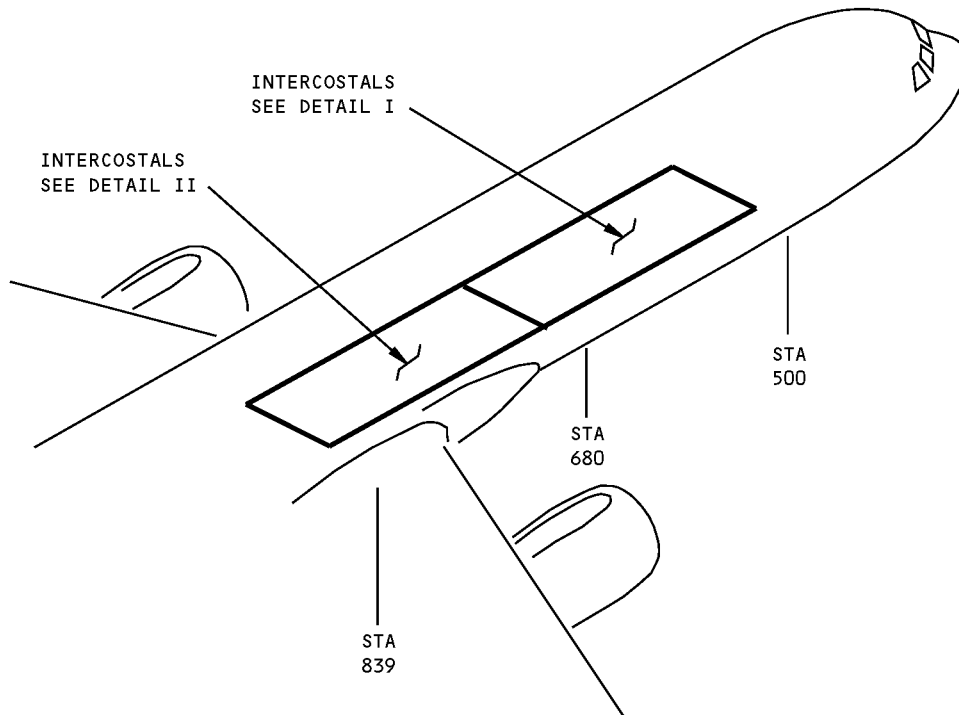
53-30-04

D634N201



757-200
STRUCTURAL REPAIR MANUAL

ALLOWABLE DAMAGE GENERAL - SECTION 43 - INTERCOSTALS



NOTES

- REFER TO 53-00-04 FOR INTERCOSTAL ALLOWABLE DAMAGE DATA

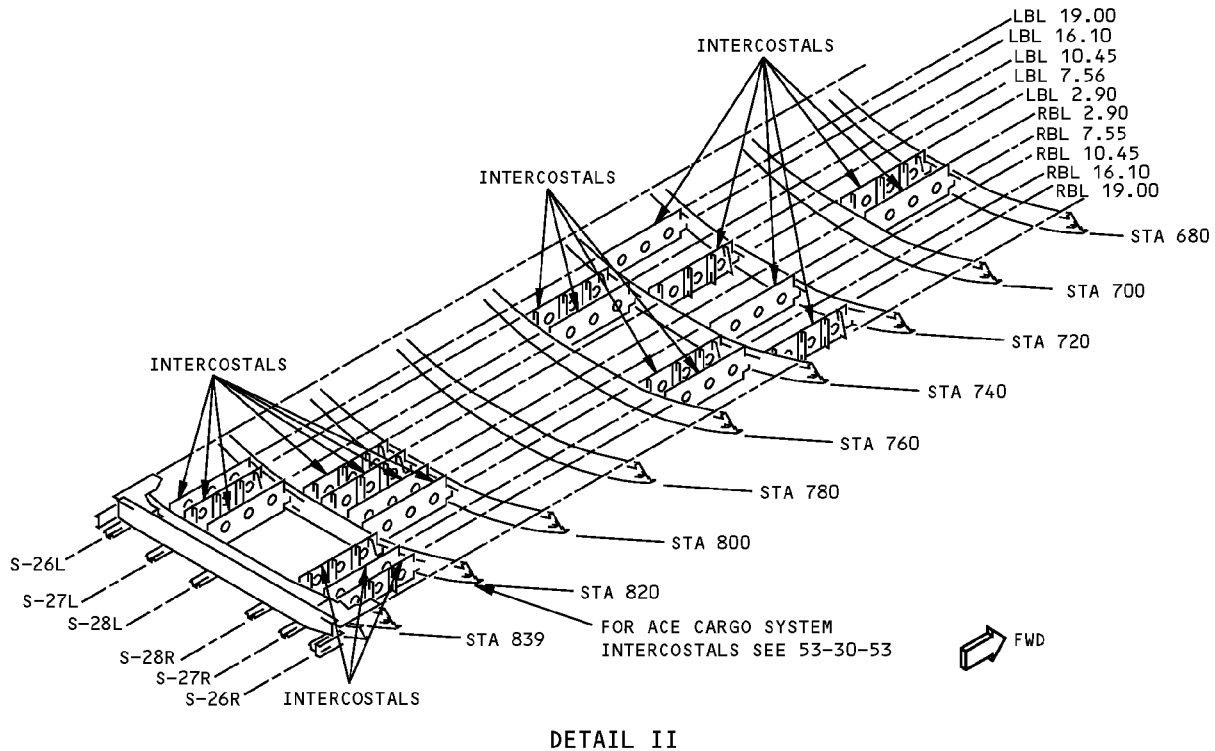
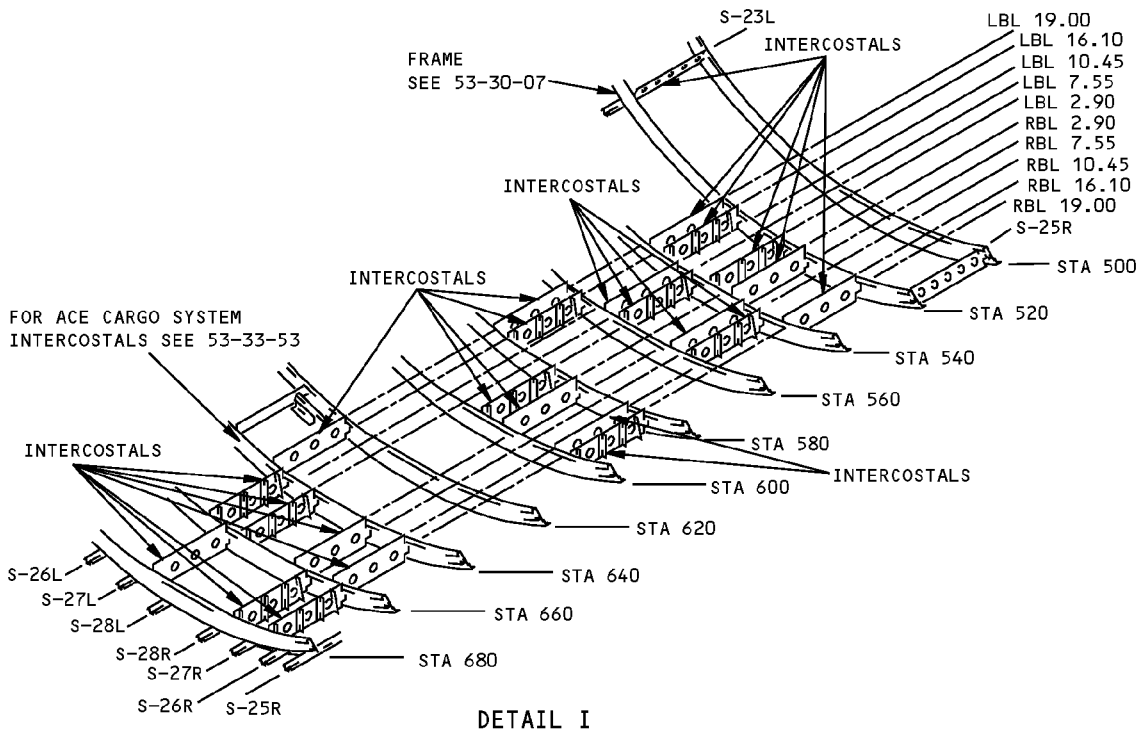
Section 43 Intercostal Allowable Damage
Figure 101 (Sheet 1 of 2)

D634N201

ALLOWABLE DAMAGE GENERAL
Page 101
53-30-04
Jan 20/2005

**757-200
STRUCTURAL REPAIR MANUAL**

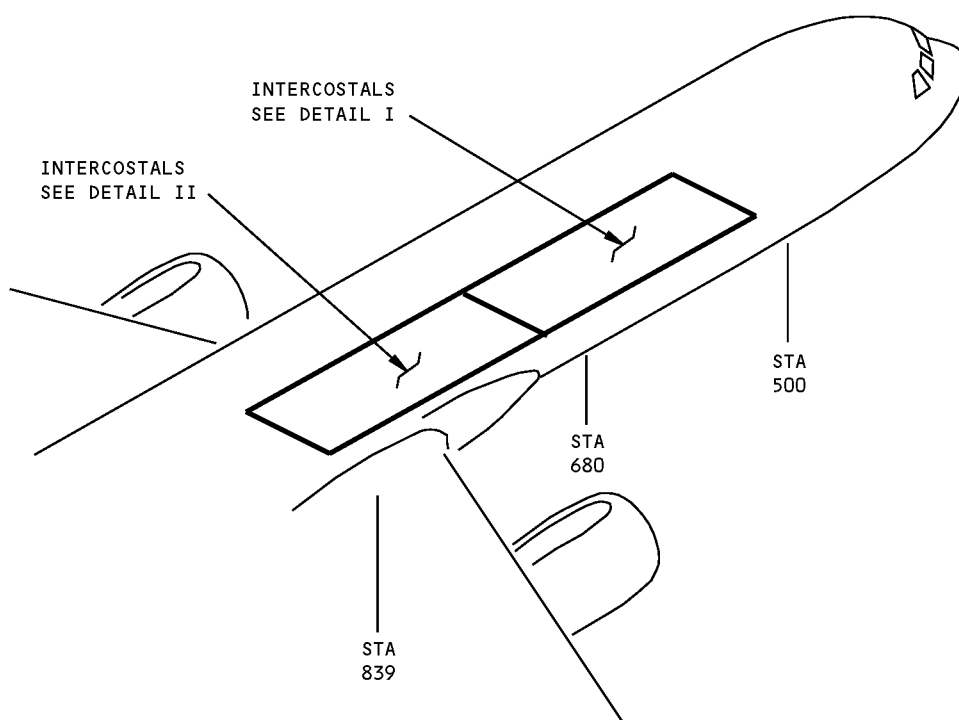
REF DWG
143N5320



**Section 43 Intercostal Allowable Damage
Figure 101 (Sheet 2 of 2)**

757-200
STRUCTURAL REPAIR MANUAL

REPAIR GENERAL - SECTION 43 - INTERCOSTALS



NOTES

- DAMAGED INTERCOSTAL COMPONENTS MAY BE REPLACED OR REPAIRED. IF REPAIRS ARE TO BE MADE, SEE 51-70 FOR TYPICAL WEB, FORMED SECTION, OR EXTRUDED SECTION REPAIRS

Section 43 Intercostal Repair
Figure 201 (Sheet 1 of 2)

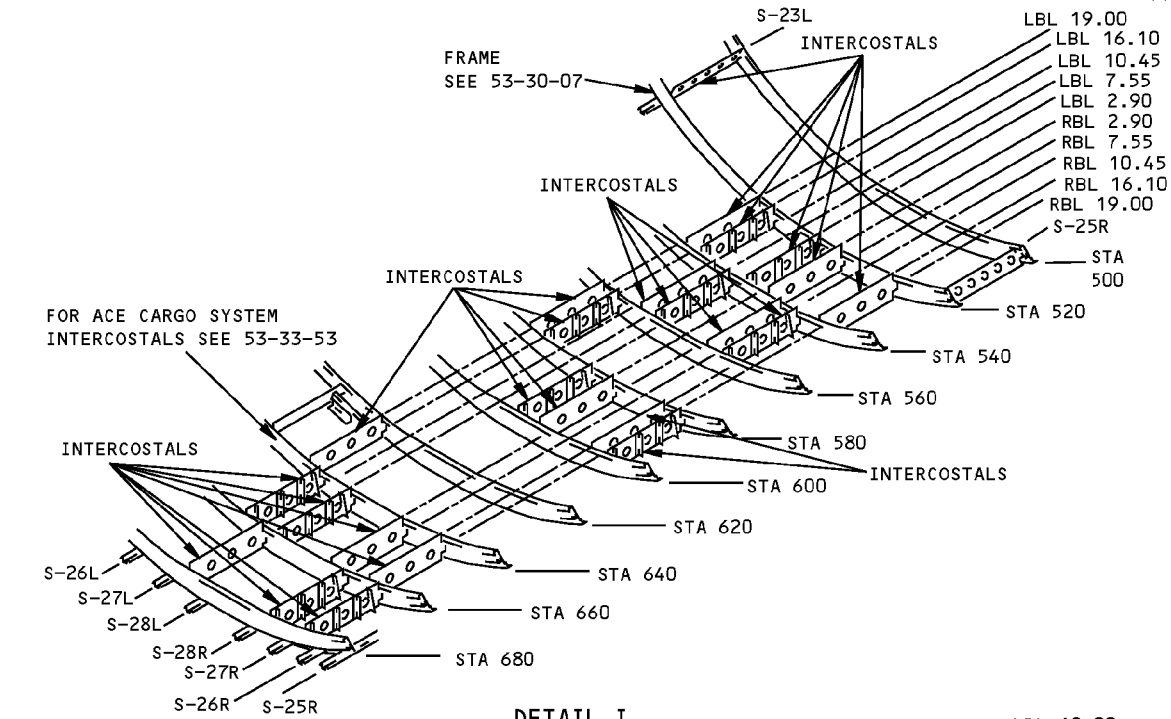
D634N201

53-30-04

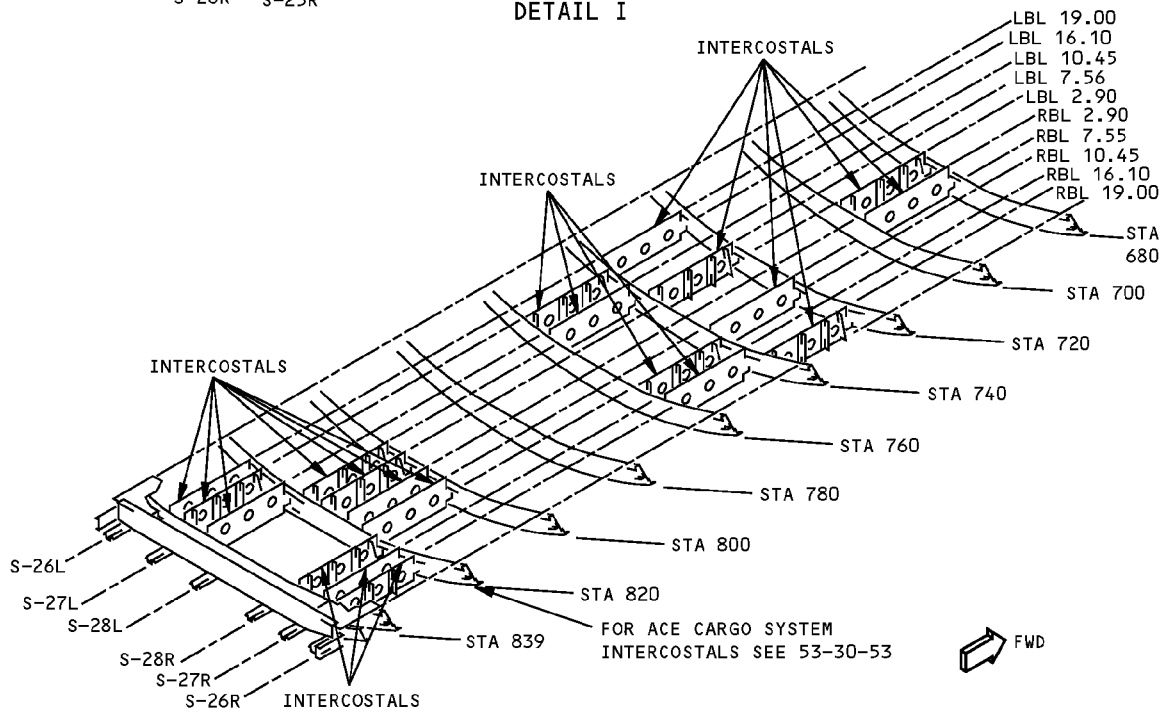
REPAIR GENERAL
Page 201
Jan 20/2005

**757-200
STRUCTURAL REPAIR MANUAL**

REF DWG
143N5320



DETAIL I

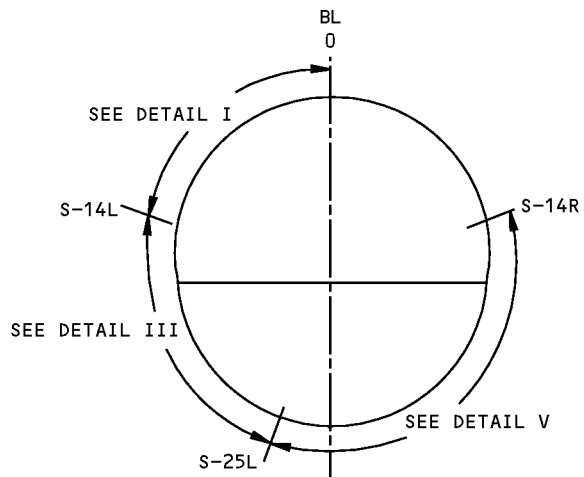
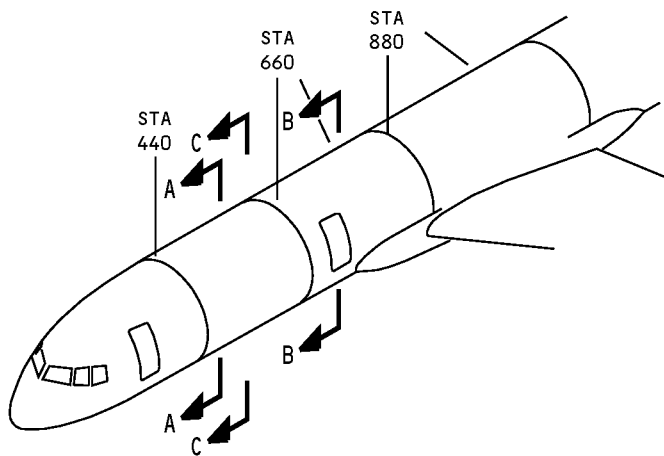


DETAIL II

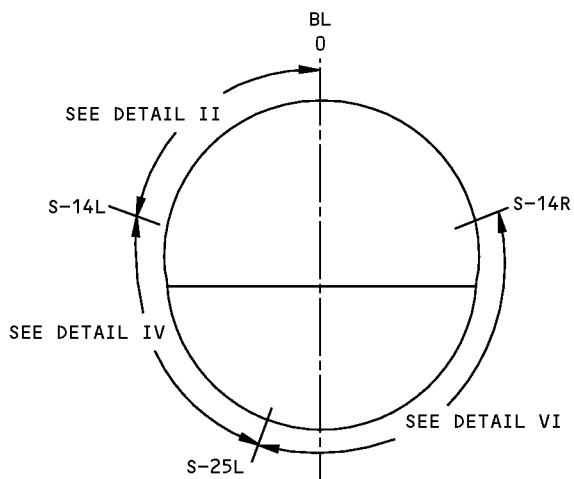
**Section 43 Intercostal Repair
Figure 201 (Sheet 2 of 2)**

**757-200
STRUCTURAL REPAIR MANUAL**

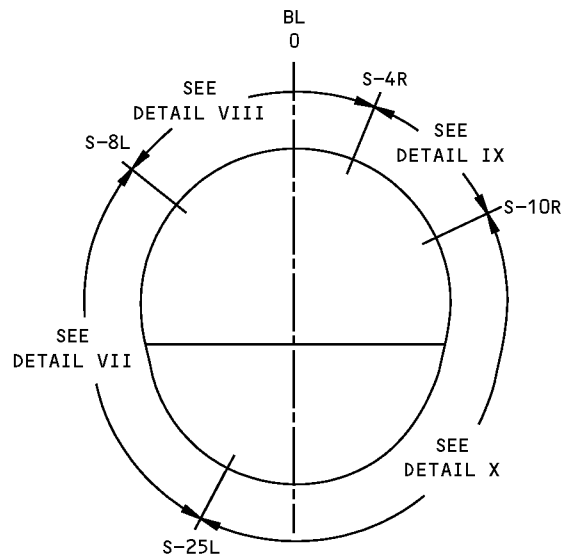
IDENTIFICATION 1 - SECTION 43 - FRAMES



DETAIL INDEX
STA 440-660
SECTION A-A



DETAIL INDEX
STA 660-880
SECTION B-B



DETAIL INDEX
STA 440-660
SECTION C-C C

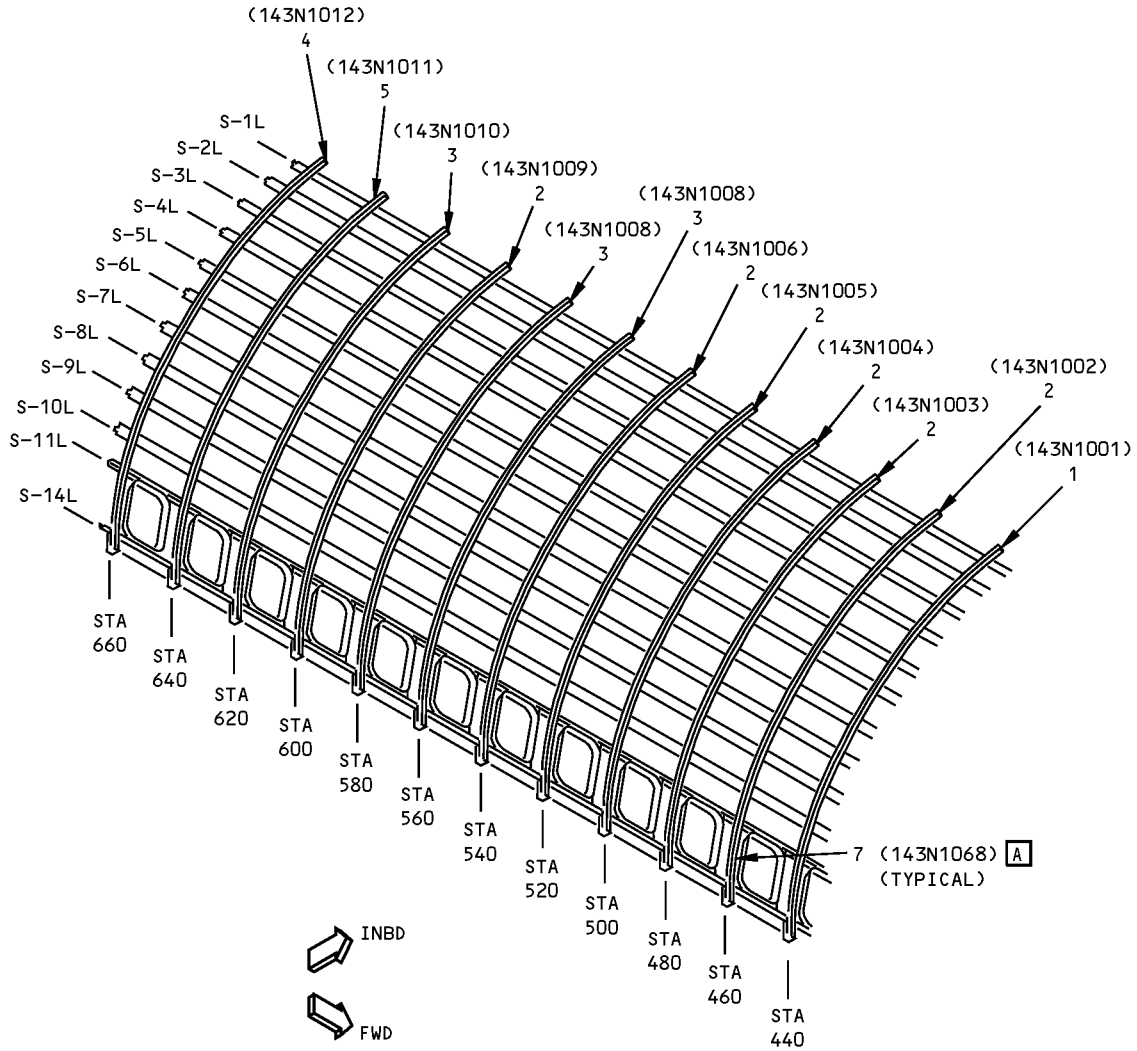
NOTES

- A FOR AIRPLANES WITH CUM LINE NUMBERS 1 THRU 158 WITH SHORT EDGE MARGINS AND WITH SB 757-53-0046 INCORPORATED
- B 757-200 PASSENGER AIRPLANES
- C 757-200SF AIRPLANES

**Section 43 Frame Identification
Figure 1 (Sheet 1 of 16)**

**757-200
STRUCTURAL REPAIR MANUAL**

REFERENCE DRAWING
140N1510



LEFT SIDE IS SHOWN, RIGHT SIDE IS OPPOSITE

DETAIL I



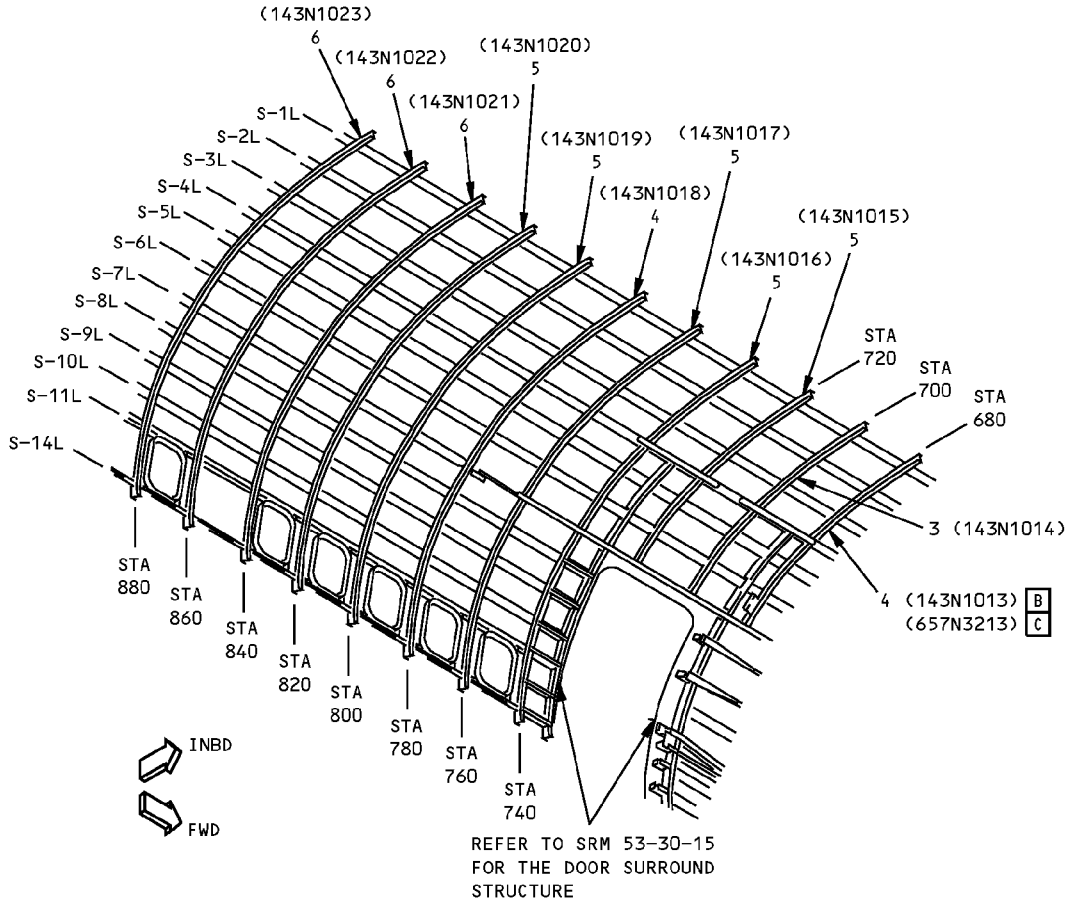
**Section 43 Frame Identification
Figure 1 (Sheet 2 of 16)**

IDENTIFICATION 1
Page 2
Jan 20/2006

53-30-07

D634N201

**757-200
STRUCTURAL REPAIR MANUAL**



LEFT SIDE IS SHOWN, RIGHT SIDE OPPOSITE
DETAIL II

ITEM	DESCRIPTION	GAGE	MATERIAL	EFFECTIVITY
1	FRAME		BAC1517-2192 CLAD 7075-T6	
2	FRAME		BAC1517-2156 CLAD 7075-T6	
3	FRAME		BAC1517-2157 CLAD 7075-T6	
4	FRAME		BAC1517-2155 CLAD 7075-T6	
5	FRAME		BAC1517-2158 CLAD 7075-T6	
6	FRAME		BAC1517-2159 CLAD 7075-T6	
7	DOUBLER	0.125	CLAD 7075-T6	A
8	DOUBLER	0.063	BAC1517-2158 CLAD 7075-T6	C
	DOUBLER CHORD	0.063	BAC1517-2158 CLAD 7075-T6	C

LIST OF MATERIALS FOR DETAILS I AND II

**Section 43 Frame Identification
Figure 1 (Sheet 3 of 16)**

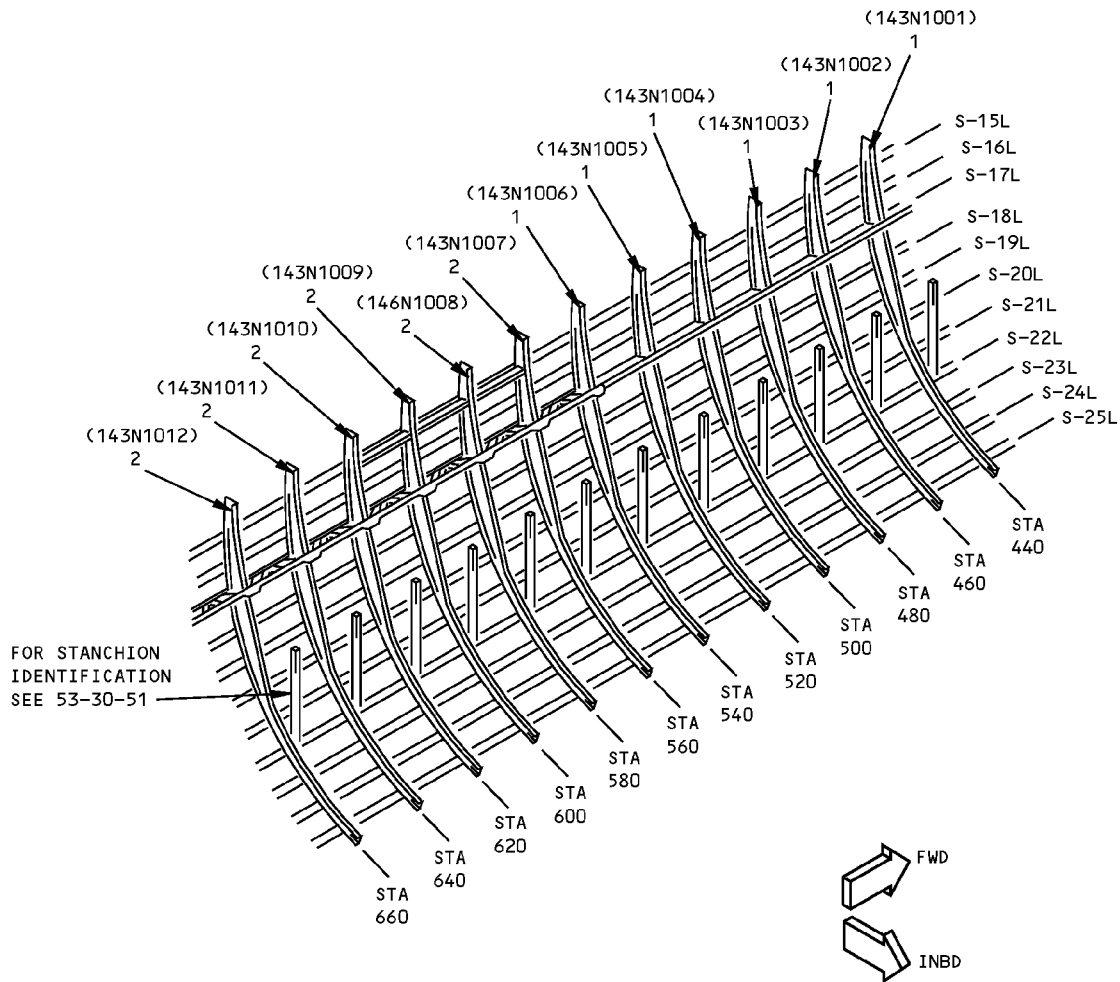
D634N201

53-30-07

IDENTIFICATION 1
Page 3
Jan 20/2006

**757-200
STRUCTURAL REPAIR MANUAL**

REF DWG
140N1510



LEFT SIDE VIEW
DETAIL III

LIST OF
MATL

**Section 43 Frame Identification
Figure 1 (Sheet 4 of 16)**

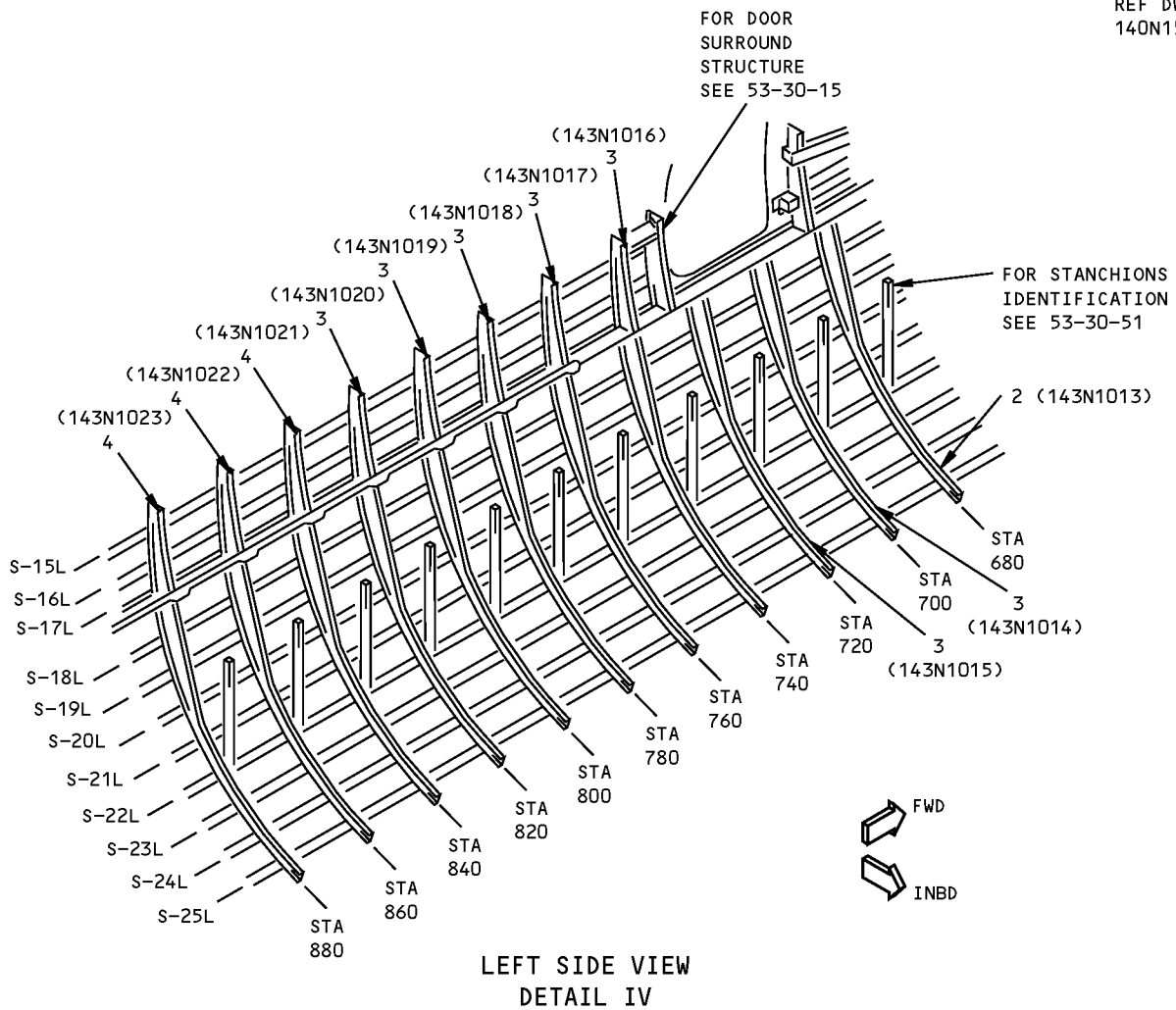
IDENTIFICATION 1
Page 4
Jan 20/2006

53-30-07

D634N201

**757-200
STRUCTURAL REPAIR MANUAL**

REF DWG
140N1510



**LEFT SIDE VIEW
DETAIL IV**

ITEM	DESCRIPTION	GAGE	MATERIAL	EFFECTIVITY
1	FRAME FAILSAFE CHORD	0.045	CLAD 7075-T6 BAC1490-2763 7075-T6	
2	FRAME FAILSAFE CHORD	0.056	CLAD 7075-T6 BAC1490-2763 7075-T6	
3	FRAME FAILSAFE CHORD	0.063	CLAD 7075-T6 BAC1490-2763 7075-T6	
4	FRAME FAILSAFE CHORD	0.071	CLAD 7075-T6 BAC1490-2770 7075-T6	

LIST OF MATERIALS FOR DETAILS III AND IV

**Section 43 Frame Identification
Figure 1 (Sheet 5 of 16)**

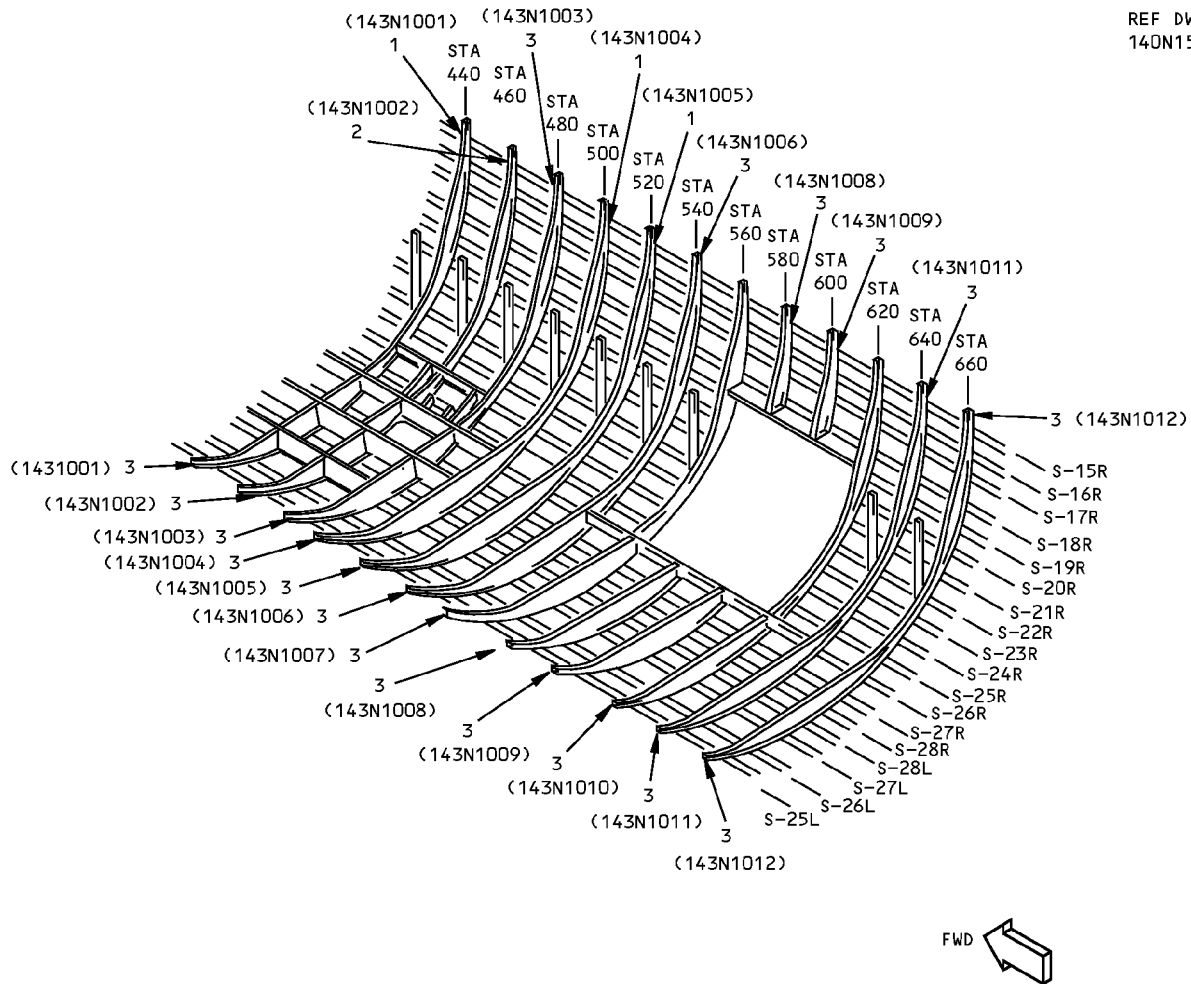
IDENTIFICATION 1
Page 5
Jan 20/2006

53-30-07

D634N201

**757-200
STRUCTURAL REPAIR MANUAL**

REF DWG
140N1510



DETAIL V

ITEM	DESCRIPTION	GAGE	MATERIAL	EFFECTIVITY
1	FRAME FAILSAFE CHORD	0.045	CLAD 7075-T6 BAC1490-2763 7075-T6	
2	FRAME FAILSAFE CHORD	0.045	CLAD 7075-T6 BAC1490-2770 7075-T6	
3	FRAME FAILSAFE CHORD	0.056	CLAD 7075-T6 BAC1490-2763 7075-T6	

LIST OF MATERIALS FOR DETAIL V

**Section 43 Frame Identification
Figure 1 (Sheet 6 of 16)**

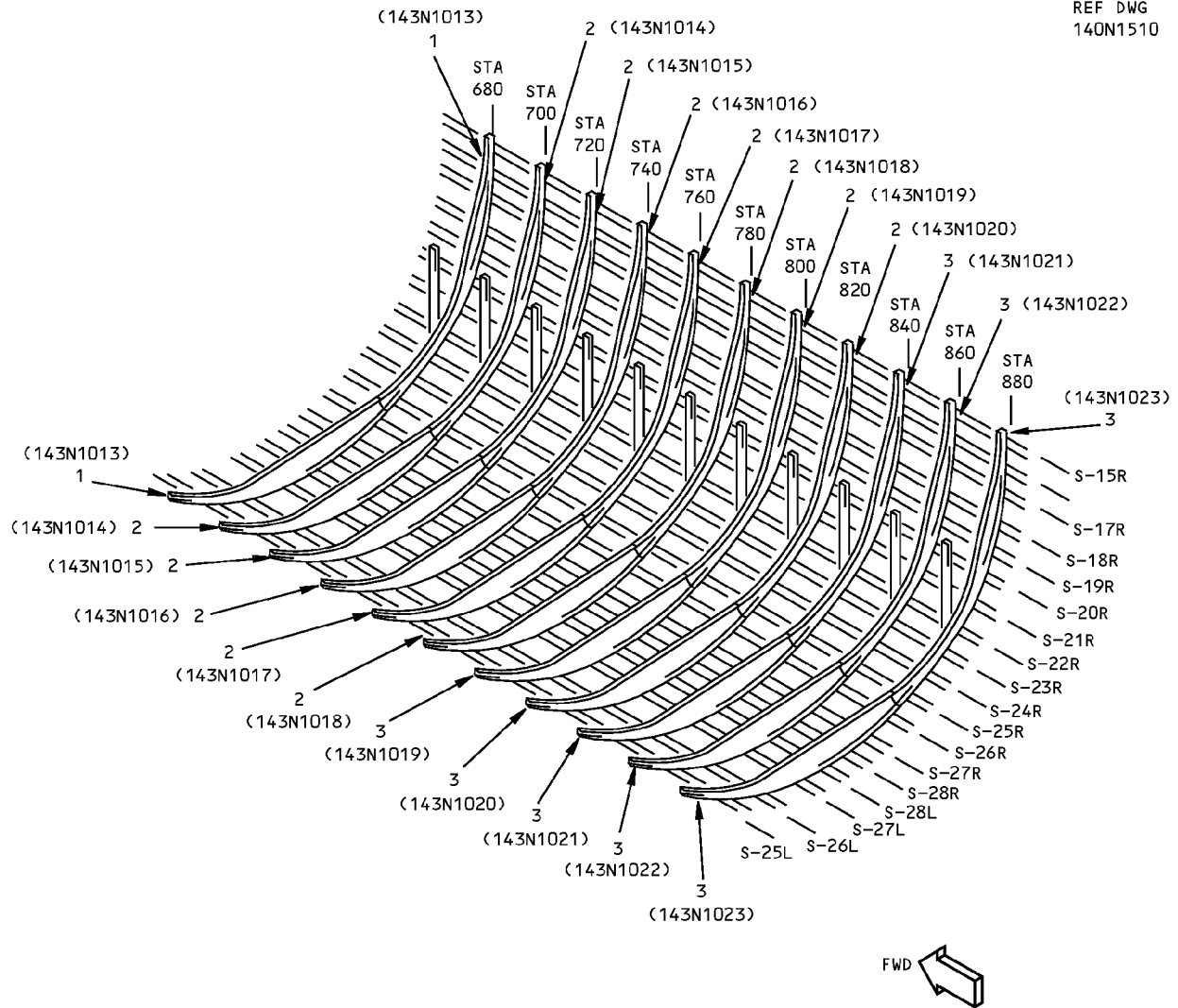
IDENTIFICATION 1
Page 6
Jan 20/2006

53-30-07

D634N201

**757-200
STRUCTURAL REPAIR MANUAL**

REF DWG
140N1510



DETAIL VI

ITEM	DESCRIPTION	GAGE	MATERIAL	EFFECTIVITY
1	FRAME FAILSAFE CHORD	0.056	CLAD 7075-T6 BAC1490-2763 7075-T6	
2	FRAME	0.063	CLAD 7075-T6 BAC1490-2763 7075-T6	
3	FRAME	0.071	CLAD 7075-T6 BAC1490-2770 7075-T6	

LIST OF MATERIALS FOR DETAIL VI

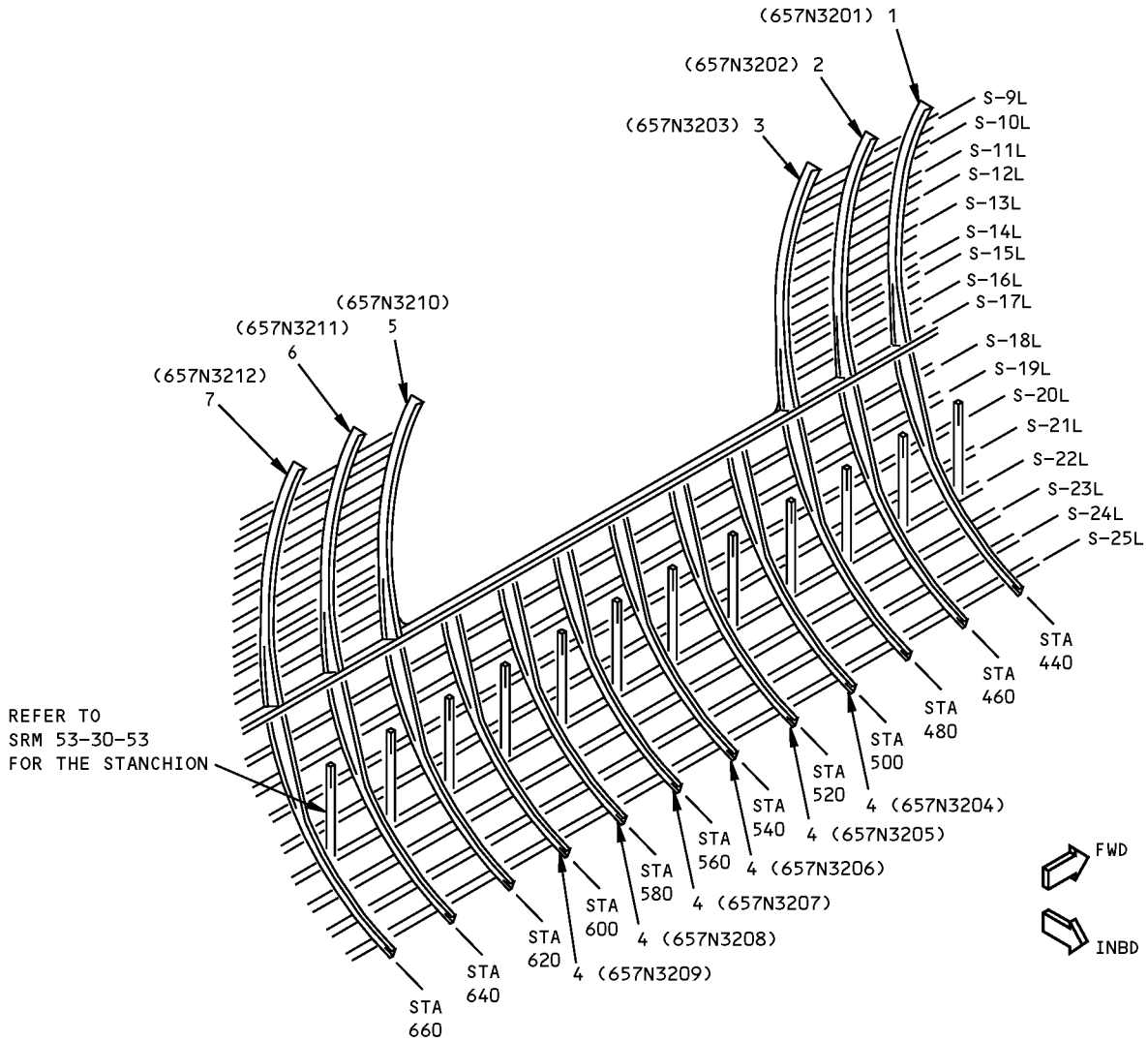
**Section 43 Frame Identification
Figure 1 (Sheet 7 of 16)**

IDENTIFICATION 1
Page 7
Jan 20/2006

53-30-07

D634N201

**757-200
STRUCTURAL REPAIR MANUAL**



LEFT SIDE IS SHOWN
DETAIL VII

**Section 43 Frame Identification
Figure 1 (Sheet 8 of 16)**



**757-200
STRUCTURAL REPAIR MANUAL**

ITEM	DESCRIPTION	GAGE	MATERIAL	EFFECTIVITY
1	FRAME ASSEMBLY			
	FRAME ZEE TOP		BAC1517-2192 7075-T6 CLAD	
	FRAME LEFT SIDE	0.045	7075-T62 CLAD	
	FAIL SAFE CHORD		BAC1490-2763 7075-T6	
2	FRAME ASSEMBLY			
	INBD CHORD		AND10133-1403 7075-T73	
	FAIL SAFE CHORD		BAC1490-2763 7075-T6	
	FRAME LEFT SIDE	0.05	7075-T6 CLAD	
	FRAME WEB LEFT SIDE	0.04	7075-T6 CLAD	
3	FRAME ASSEMBLY			
	FRAME LOWER	3.0	7075-T7351	
	FRAME BOTTOM	0.063	7075-T62 CLAD	
4	FRAME ASSEMBLY			
	FRAME LEFT SIDE	0.1	7075-T6	
	FAIL SAFE CHORD		BAC1490-2763 7075-T6	
5	FRAME			
	FRAME LOWER	3.0	7075-T7351	
6	FRAME ASSEMBLY			
	FRAME WEB	0.09	7075-T6 CLAD	
	INBD CHORD		AND10134-1408 7075-T73	
	FAIL SAFE CHORD		BAC1490-2763 7075-T6	
7	FRAME ASSEMBLY			
	FRAME NARROW		BAC1517-2155 7075-T6	
	FRAME LEFT SIDE	0.09	7075-T6 CLAD	
	FAIL SAFE CHORD		BAC1490-2763 7075-T6	

**Section 43 Frame Identification
Figure 1 (Sheet 9 of 16)**

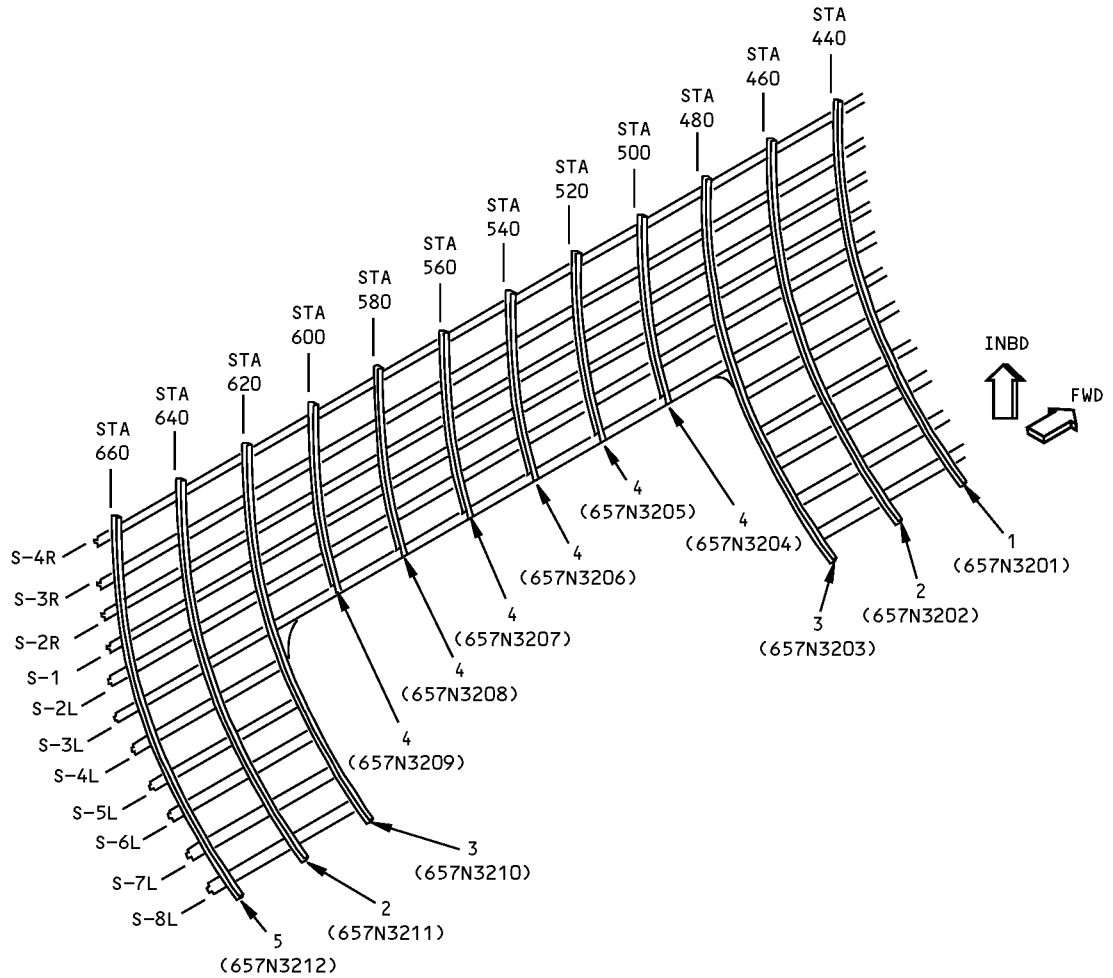
D634N201

53-30-07

IDENTIFICATION 1
Page 9
May 20/2006

**757-200
STRUCTURAL REPAIR MANUAL**

REFERENCE DRAWING
140N1510



CROWN FRAMES
LEFT AND RIGHT SIDE IS SHOWN
DETAIL VIII

**Section 43 Frame Identification
Figure 1 (Sheet 10 of 16)**

IDENTIFICATION 1
Page 10
May 20/2006

53-30-07

D634N201



757-200
STRUCTURAL REPAIR MANUAL

ITEM	DESCRIPTION	GAGE	MATERIAL	EFFECTIVITY
1	FRAME FRAME ZEE TOP		BAC1517-2192 7075-T6 CLAD	
2	FRAME ASSEMBLY FRAME CROWN-J CROWN FRAME DOUBLER	0.071	BAC1506-856 7075-T73 7075-T6 CLAD	
3	FRAME FRAME UPPER		BAC1509-100210 7075-T73	
4	FRAME FRAME ZEE		BAC1517-2158 7075-T6 CLAD	
5	FRAME FRAME NARROW		BAC1517-2155 7075-T6 CLAD	

Section 43 Frame Identification
Figure 1 (Sheet 11 of 16)

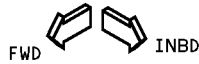
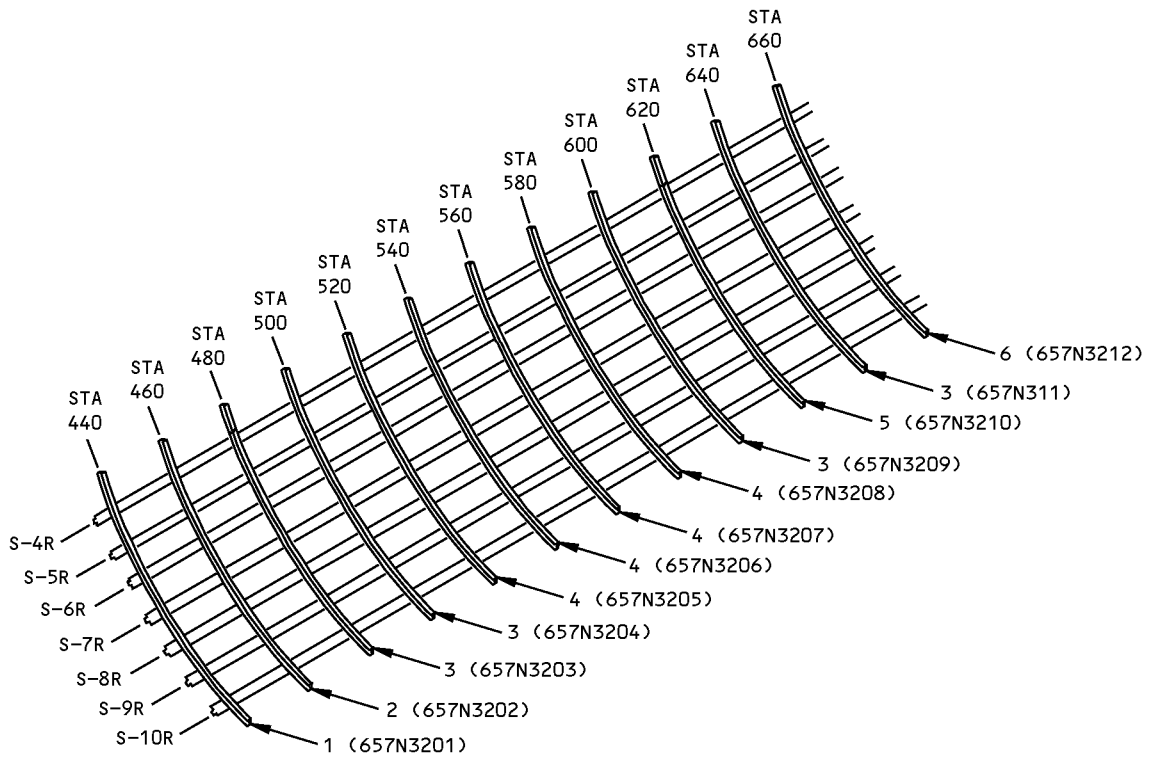
D634N201

53-30-07

IDENTIFICATION 1
Page 11
May 20/2006

**757-200
STRUCTURAL REPAIR MANUAL**

REFERENCE DRAWING
140N1510



RIGHT SIDE IS SHOWN

CROWN FRAMES
DETAIL IX

**Section 43 Frame Identification
Figure 1 (Sheet 12 of 16)**

D634N201

IDENTIFICATION 1
Page 12
53-30-07 May 20/2006



757-200
STRUCTURAL REPAIR MANUAL

ITEM	DESCRIPTION	GAGE	MATERIAL	EFFECTIVITY
1	FRAME FRAME ZEE TOP		BAC1517-2192 7075-T6 CLAD	
2	FRAME FRAME ZEE		BAC1517-2156 7075-T73 CLAD	
3	FRAME FRAME ZEE		BAC1517-2158 7075-T6 CLAD	
4	FRAME FRAME ZEE		BAC1517-2157 7075-T6 CLAD	
5	FRAME ASSEMBLY FRAME ZEE DOUBLER FRAME	0.063	BAC1517-2158 7075-T6 CLAD 7075-T6 CLAD	
6	FRAME FRAME NARROW		BAC1517-2155 7075-T6 CLAD	

LIST OF MATERIALS FOR DETAIL IX

Section 43 Frame Identification
Figure 1 (Sheet 13 of 16)

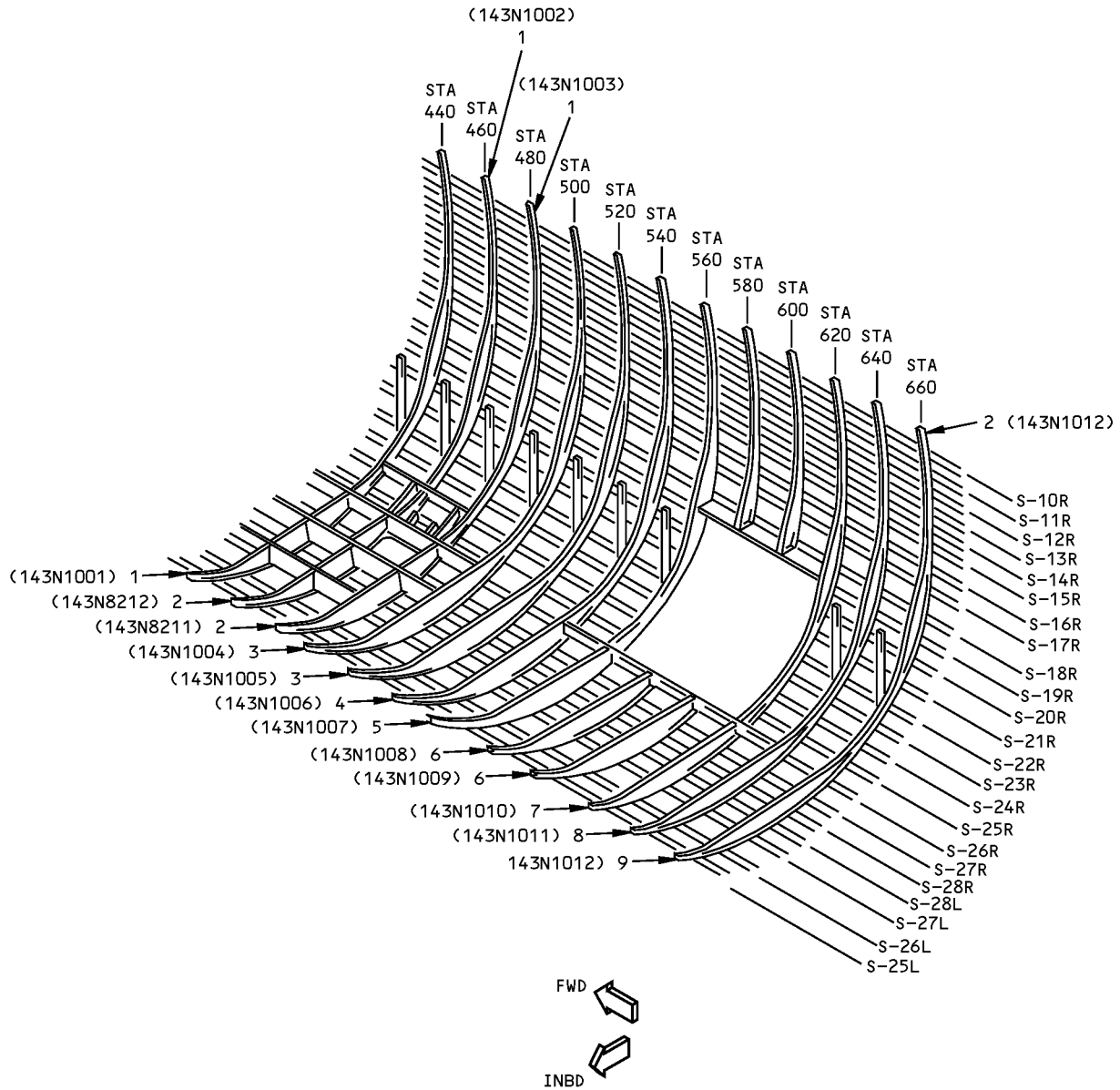
D634N201

53-30-07

IDENTIFICATION 1
Page 13
May 20/2006

**757-200
STRUCTURAL REPAIR MANUAL**

REFERENCE DRAWING
140N1510



**Section 43 Frame Identification
Figure 1 (Sheet 14 of 16)**



**757-200
STRUCTURAL REPAIR MANUAL**

ITEM	DESCRIPTION	GAGE	MATERIAL	EFFECTIVITY
1	FRAME ASSEMBLY			
	FRAME BOTTOM	0.056	7075-T6 CLAD	N0009-N0146
	FAIL SAFE CHORD		BAC1490-2763 7075-T6	N0009-N0146
	FRAME RIGHT SIDE	0.045	7075-T6 CLAD	N0009-N0146
2	FRAME ASSEMBLY			
	WEB	0.063	7075-T6	N0009-N0146
	OUTER CHORD		BAC1503-100171 7075-T73511	N0009-N0146
	FRAME RIGHT SIDE	0.045	7075-T6 CLAD	N0009-N0146
	FAIL SAFE CHORD		BAC1490-2763 7075-T6	N0009-N0146
FRAME ZEE		BAC1517-2156 7075-T6	N0009-N0146	
3	FRAME ASSEMBLY			
	FRAME BOTTOM	0.056	7075-T6 CLAD	N0009-N0146
	FAIL SAFE CHORD		BAC1490-2763 7075-T6	N0009-N0146
	FRAME RIGHT SIDE	0.045	7075-T6 CLAD	N0009-N0146
FRAME ZEE		BAC1517-2156 7075-T6	N0009-N0146	
4	FRAME ASSEMBLY			
	FRAME BOTTOM	0.056	7075-T6 CLAD	N0009-N0146
	FAIL SAFE CHORD		BAC1490-2763 7075-T6	N0009-N0146
	FRAME RIGHT SIDE	0.056	7075-T6 CLAD	N0009-N0146
FRAME ZEE		BAC1517-2156 7075-T6	N0009-N0146	
5	FRAME ASSEMBLY			
	FRAME BOTTOM	0.056	7075-T6 CLAD	N0009-N0146
	FAIL SAFE CHORD		BAC1490-2763 7075-T6	N0009-N0146
	WEB	0.056	7075-T6 CLAD	N0009-N0146
	WEB	0.071	7075-T6	N0009-N0047
	WEB	0.080	2024-T3	N0048-N0146
	CHORD INNER		BAC1505-100849 7075-T73	N0009-N0047
	CHORD INNER		BAC1505-100849 2024-T42	N0048-N0146
	CHORD OUTER		BAC1503-100275 7075-T73	N0009-N0047
	CHORD OUTER		BAC1503-100275 2024-T42	N0048-N0146
FRAME ZEE		BAC1517-2157 7075-T6	N0009-N0146	
6	FRAME ASSEMBLY			
	FRAME BOTTOM	0.056	7075-T6 CLAD	N0009-N0146
	FAIL SAFE CHORD		BAC1490-2763 7075-T62	N0009-N0146
	FRAME RIGHT SIDE	0.056	7075-T6 CLAD	N0009-N0146
FRAME ZEE		BAC1517-2157 7075-76	N0009-N0146	

LIST OF MATERIALS FOR DETAIL X

**Section 43 Frame Identification
Figure 1 (Sheet 15 of 16)**



**757-200
STRUCTURAL REPAIR MANUAL**

ITEM	DESCRIPTION	GAGE	MATERIAL	EFFECTIVITY
7	FRAME ASSEMBLY			
	FRAME BOTTOM	0.056	7075-T6 CLAD	N0009-N0146
	FAIL SAFE CHORD		BAC1490-2763 7075-T6	N0009-N0146
	WEB	0.071	7075-T6	N0009-N0047
	WEB	0.08	2024-T42	N0048-N0146
	CHORD INNER		BAC1503-100698 7075T73	N0009-N0047
	CHORD INNER		BAC1503-100698 2024T42	N0048-N0146
	CHORD OUTER		BAC1503-100275 7075-T73	N0009-N0047
	CHORD OUTER		BAC1503-100275 2024T42	N0048-N0146
	FRAME ZEE		BAC1517-2158 7075-T6	N0009-N0146
8	FRAME ASSEMBLY			
	FRAME BOTTOM	0.056	7075-T6 CLAD	N0009-N0146
	FAIL SAFE CHORD		BAC1490-2763 7075-T6	N0009-N0146
	FRAME RIGHT SIDE	0.063	7075-T6 CLAD	N0009-N0016
	FRAME RIGHT SIDE	0.056	7075-T6 CLAD	N0017-N0146
	FRAME ZEE		BAC1517-2158 7075-T6 CLAD	N0009-N0146
9	FRAME ASSEMBLY			
	FRAME BOTTOM	0.056	7075-T6 CLAD	N0009-N0146
	FAIL SAFE CHORD		BAC1490-2763 7075-T6	N0009-N0146
	FRAME RIGHT SIDE	0.056	7075-T6 CLAD	N0009-N0016
	FRAME RIGHT SIDE	0.045	7075-T6 CLAD	N0017-N0024
	FRAME NARROW		BAC1517-2155 T6	N0009-N0146

LIST OF MATERIALS FOR DETAIL X
(CONTINUED)

**Section 43 Frame Identification
Figure 1 (Sheet 16 of 16)**

D634N201

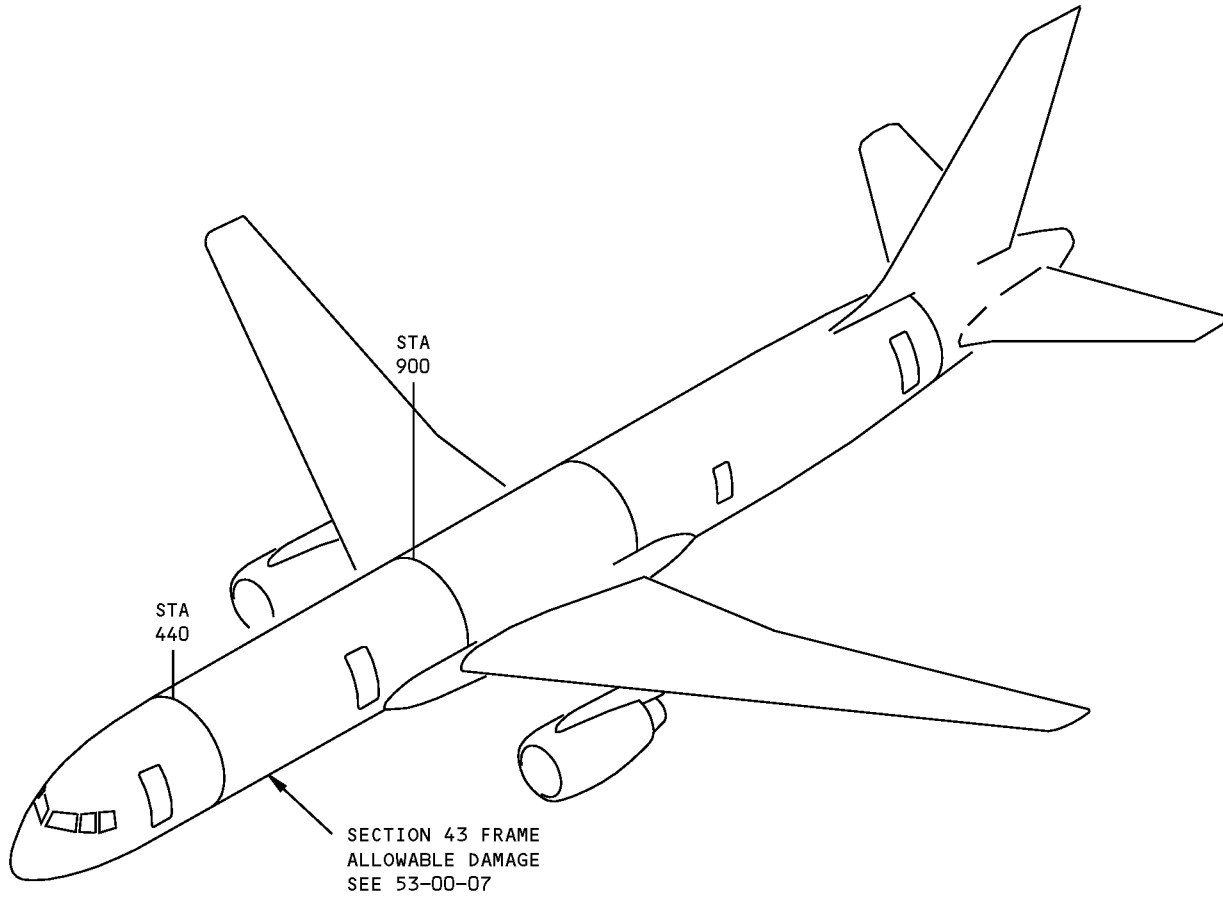
53-30-07

IDENTIFICATION 1
Page 16
May 20/2006



**757-200
STRUCTURAL REPAIR MANUAL**

ALLOWABLE DAMAGE GENERAL - SECTION 43 - FRAMES



**Section 43 Frame Allowable Damage
Figure 101**

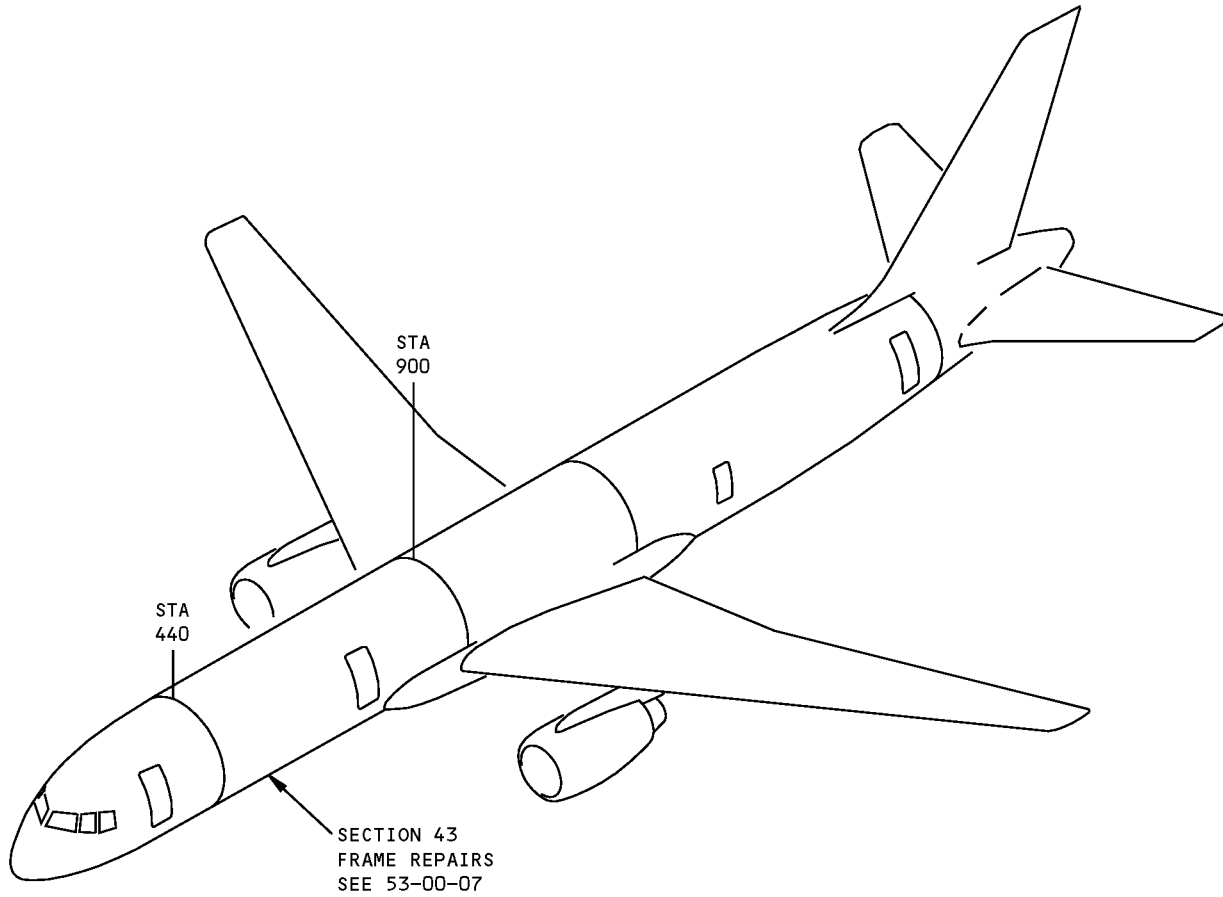
D634N201

ALLOWABLE DAMAGE GENERAL
Page 101
53-30-07
Jan 20/2007



757-200
STRUCTURAL REPAIR MANUAL

REPAIR GENERAL - SECTION 43 - FRAMES



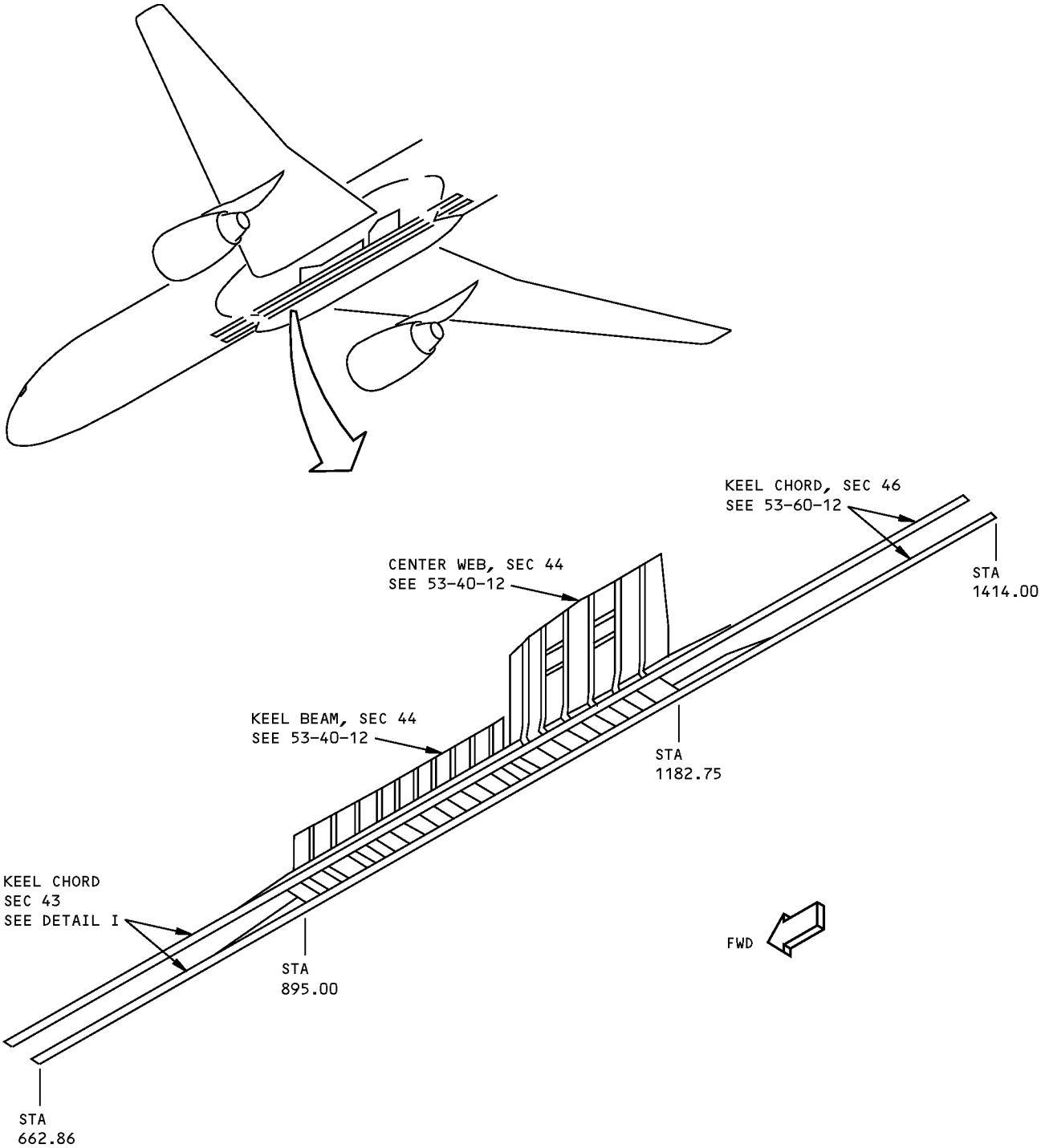
Section 43 Frame Repairs
Figure 201

D634N201

REPAIR GENERAL
Page 201
53-30-07
Jan 20/2005

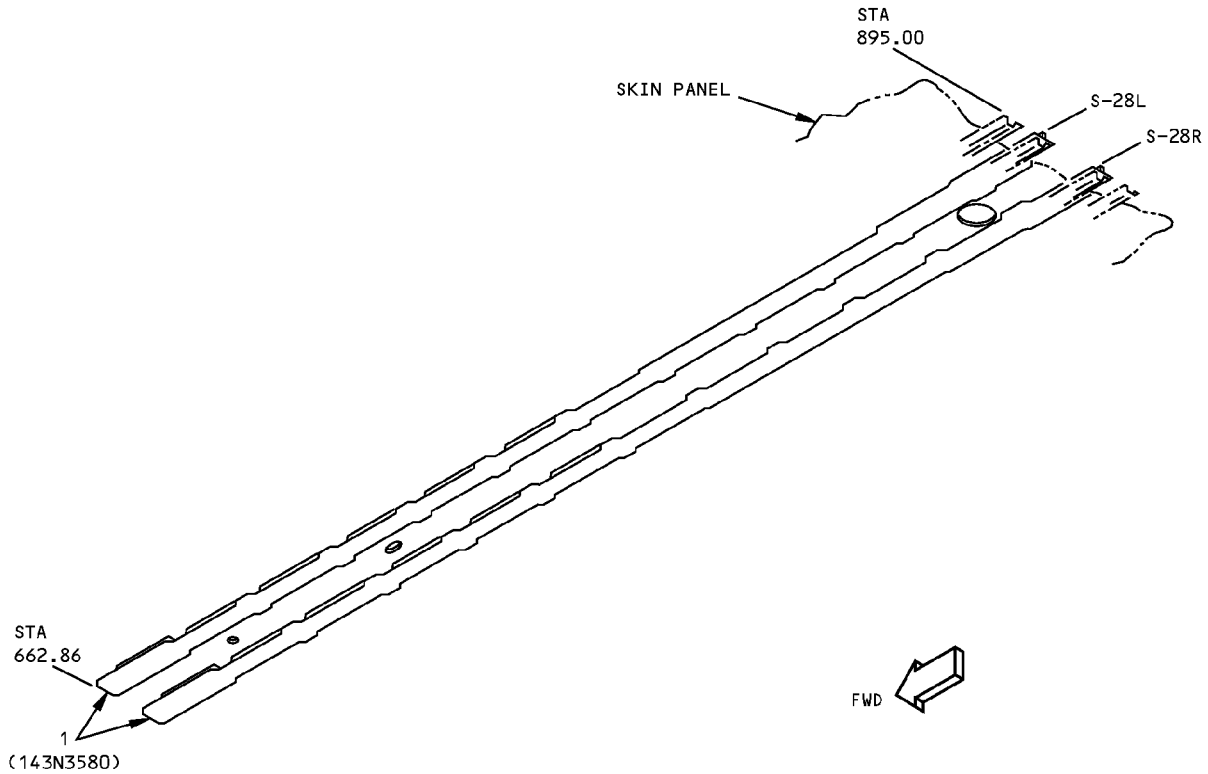
**757-200
STRUCTURAL REPAIR MANUAL**

IDENTIFICATION 1 - SECTION 43 - KEEL BEAM STRUCTURE



**Section 43 Keel Beam Structure Identification
Figure 1 (Sheet 1 of 2)**

**757-200
STRUCTURAL REPAIR MANUAL**



DETAIL I

ITEM	DESCRIPTION	GAGE	MATERIAL	EFFECTIVITY
1	KEEL BEAM CHORD		BAC1505-101246 7075-T73511	

LIST OF MATERIALS FOR DETAIL I

**Section 43 Keel Beam Structure Identification
Figure 1 (Sheet 2 of 2)**

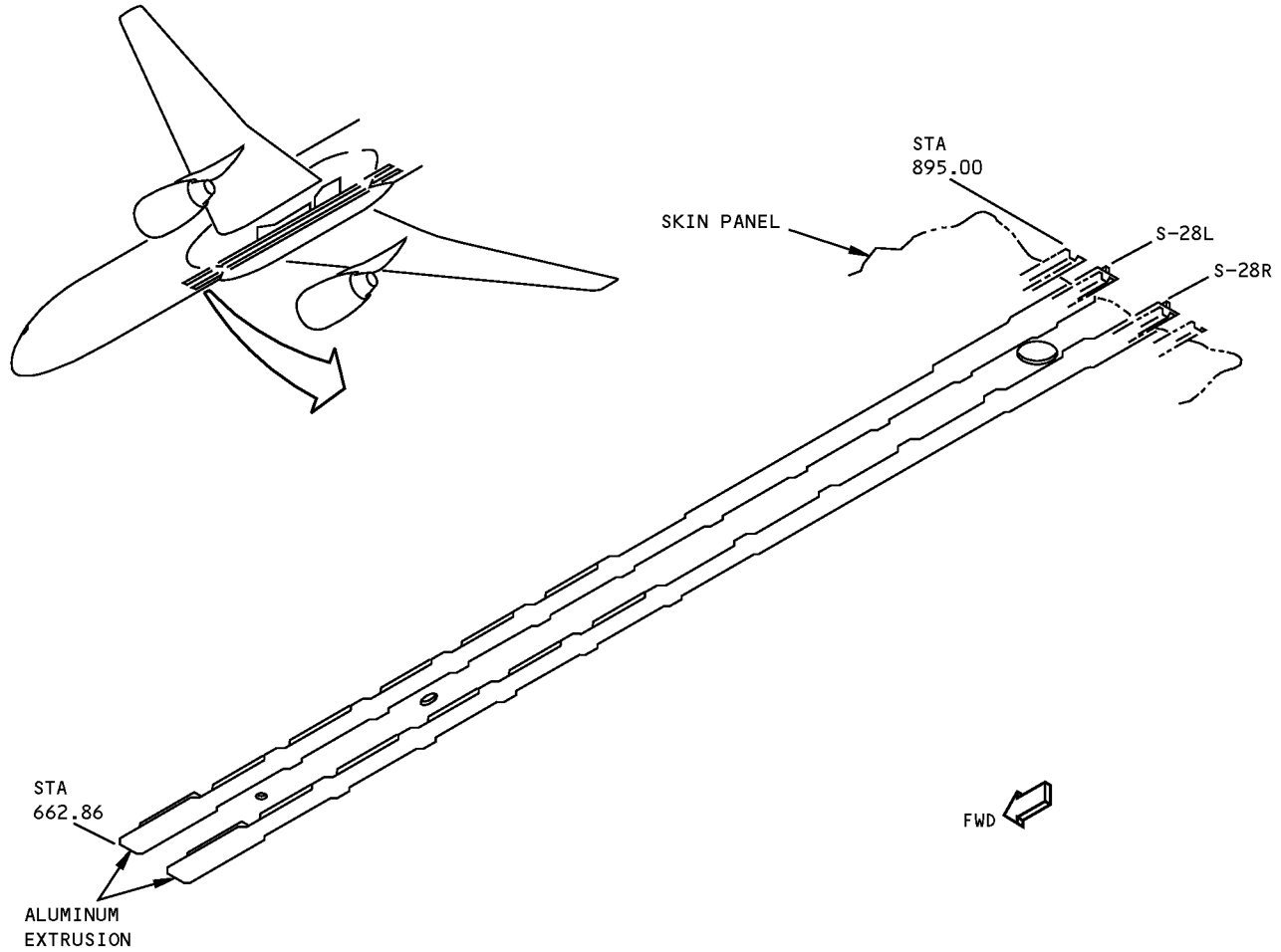
D634N201

53-30-12

IDENTIFICATION 1
Page 2
Jan 20/2005

**757-200
STRUCTURAL REPAIR MANUAL**

ALLOWABLE DAMAGE 1 - SECTION 43 - KEEL BEAM STRUCTURE



DESCRIPTION	CRACKS	NICKS, GOUGES AND CORROSION	DENTS	HOLES AND PUNCTURES
CHORDS	A	B	NOT ALLOWED	NOT ALLOWED

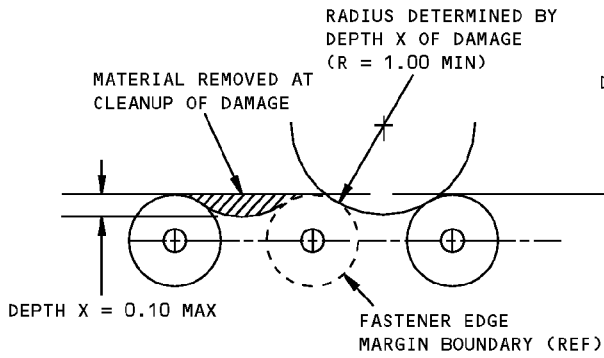
NOTES

- REFINISH REWORKED AREAS PER 51-20 OF THE MAINTENANCE MANUAL

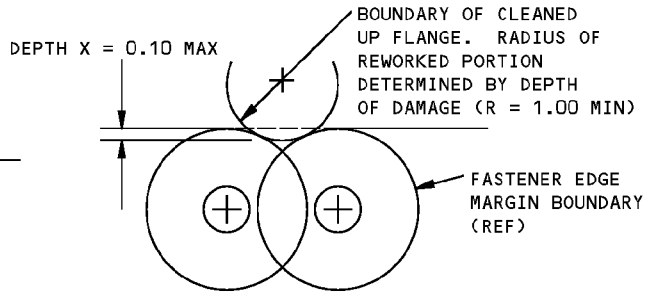
- A** CRACKS NOT ALLOWED. EDGE CRACKS MUST BE REMOVED PER DETAILS I AND III. ELSEWHERE THE AFFECTED PART MUST BE REPLACED OR REPAIRED
- B** REMOVE DAMAGE PER DETAILS I, II, III AND IV. THE TOTAL CROSS-SECTIONAL AREA REMOVED MUST NOT EXCEED 10% OF THE ORIGINAL CROSS-SECTIONAL AREA OF THE FLANGE

**Section 43 Keel Beam Structure Allowable Damage
Figure 101 (Sheet 1 of 2)**

STRUCTURAL REPAIR MANUAL

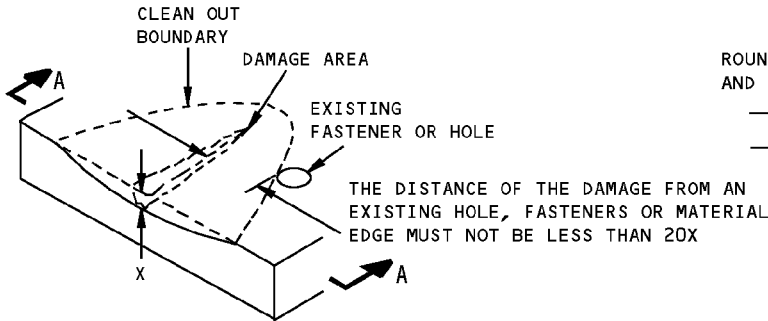


DAMAGE CLEANUP OF EDGES WHERE FASTENER EDGE MARGINS DO NOT OVERLAP

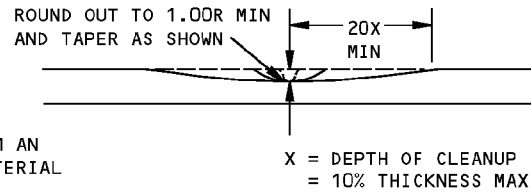


DAMAGE CLEANUP OF EDGES WHERE FASTENER EDGE MARGINS OVERLAP

DETAIL I

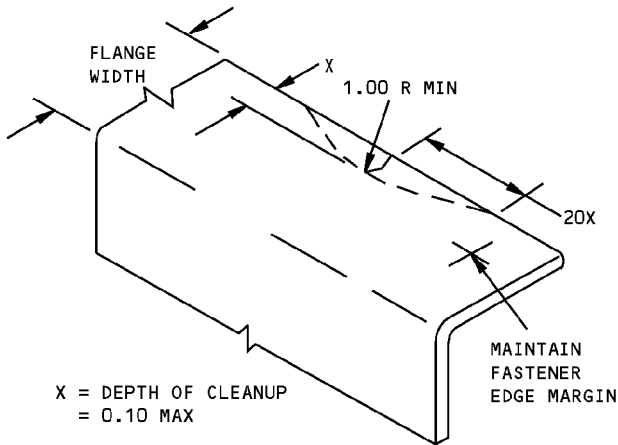


REMOVAL OF NICK, GOUGE AND SCRATCH DAMAGE ON A SURFACE



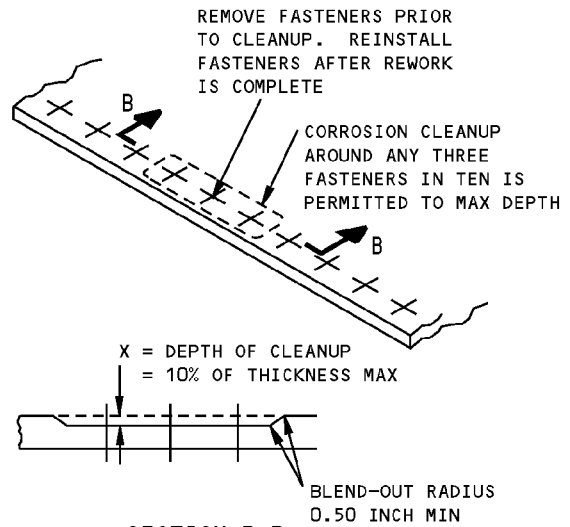
SECTION A-A

DETAIL II



REMOVAL OF NICK OR CRACK DAMAGE ON AN EDGE

DETAIL III



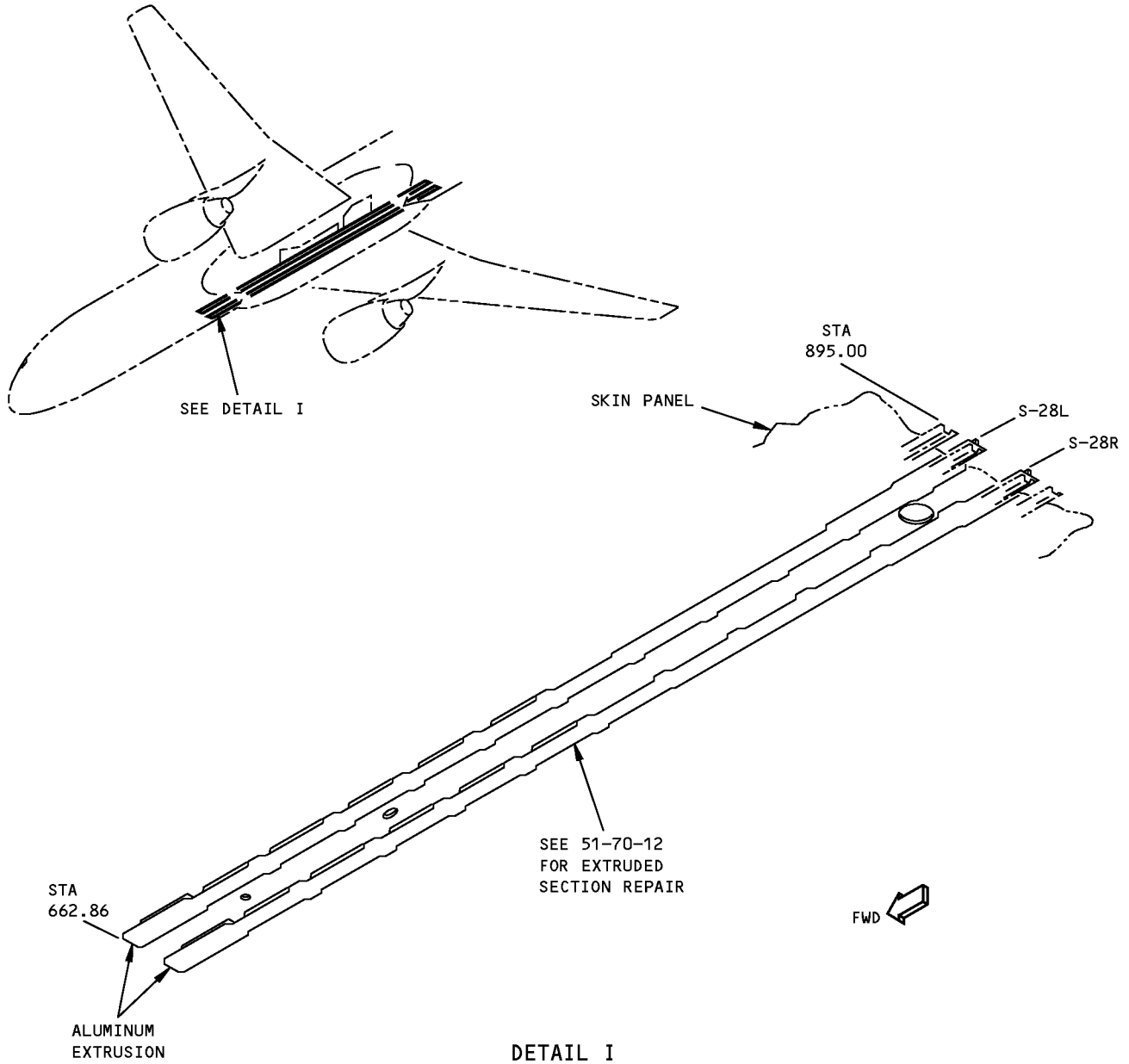
SECTION B-B

CORROSION CLEANUP
DETAIL IV

**Section 43 Keel Beam Structure Allowable Damage
Figure 101 (Sheet 2 of 2)**

**757-200
STRUCTURAL REPAIR MANUAL**

REPAIR GENERAL - SECTION 43 - KEEL BEAM STRUCTURE



NOTES

- THIS IS A CATEGORY A REPAIR. THE INSPECTIONS GIVEN IN THE MAINTENANCE PLANNING DATA (MPD) ARE SUFFICIENT TO MAINTAIN THE DAMAGE TOLERANCE OF THE INITIAL STRUCTURE WITH THIS REPAIR INSTALLED. REFER TO SRM 51-00-06 FOR REPAIR CATEGORIES AND DEFINITIONS.

L50356 S0006802482_V2

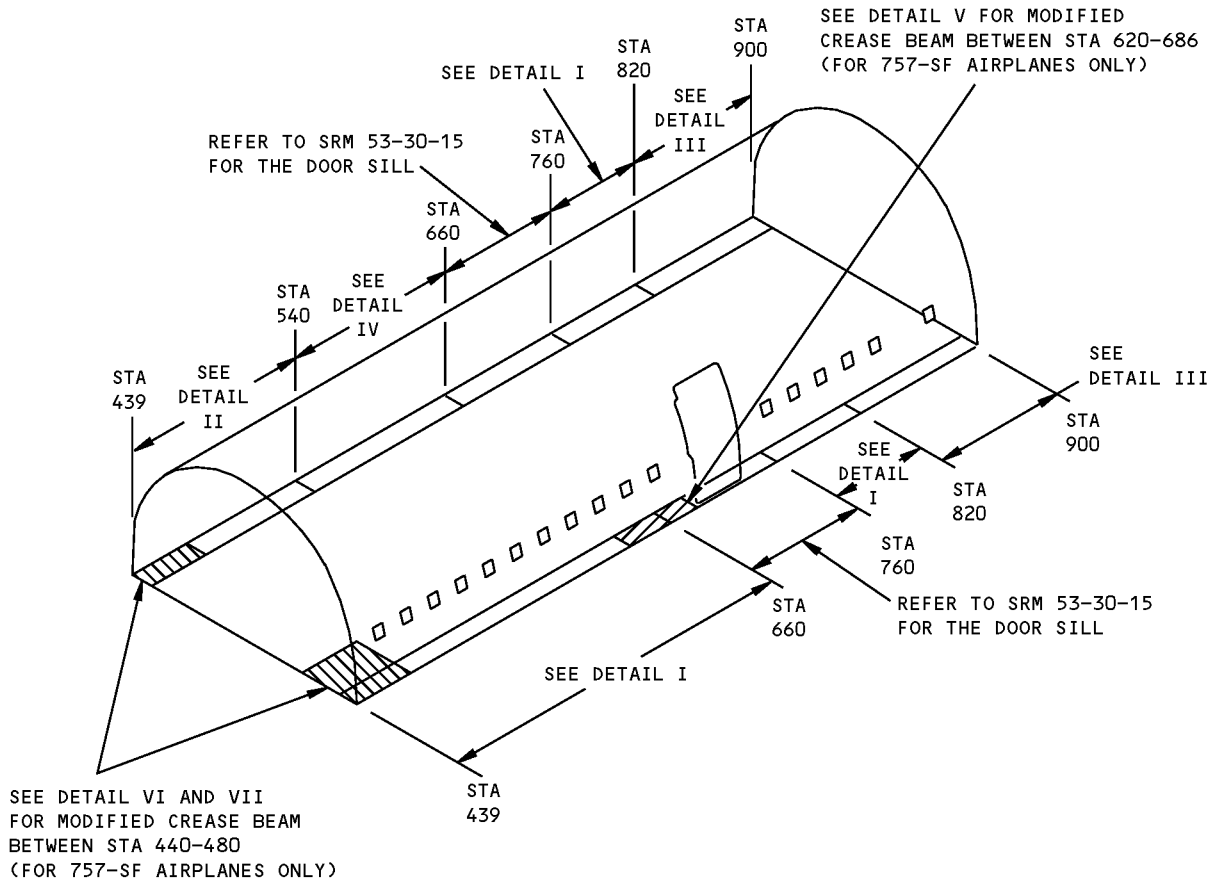
**Section 43 Keel Chord Repair
Figure 201**

D634N201

**757-200
STRUCTURAL REPAIR MANUAL**

IDENTIFICATION 1 - SECTION 43 - CREASE BEAM

REFERENCE DRAWING
143N5520



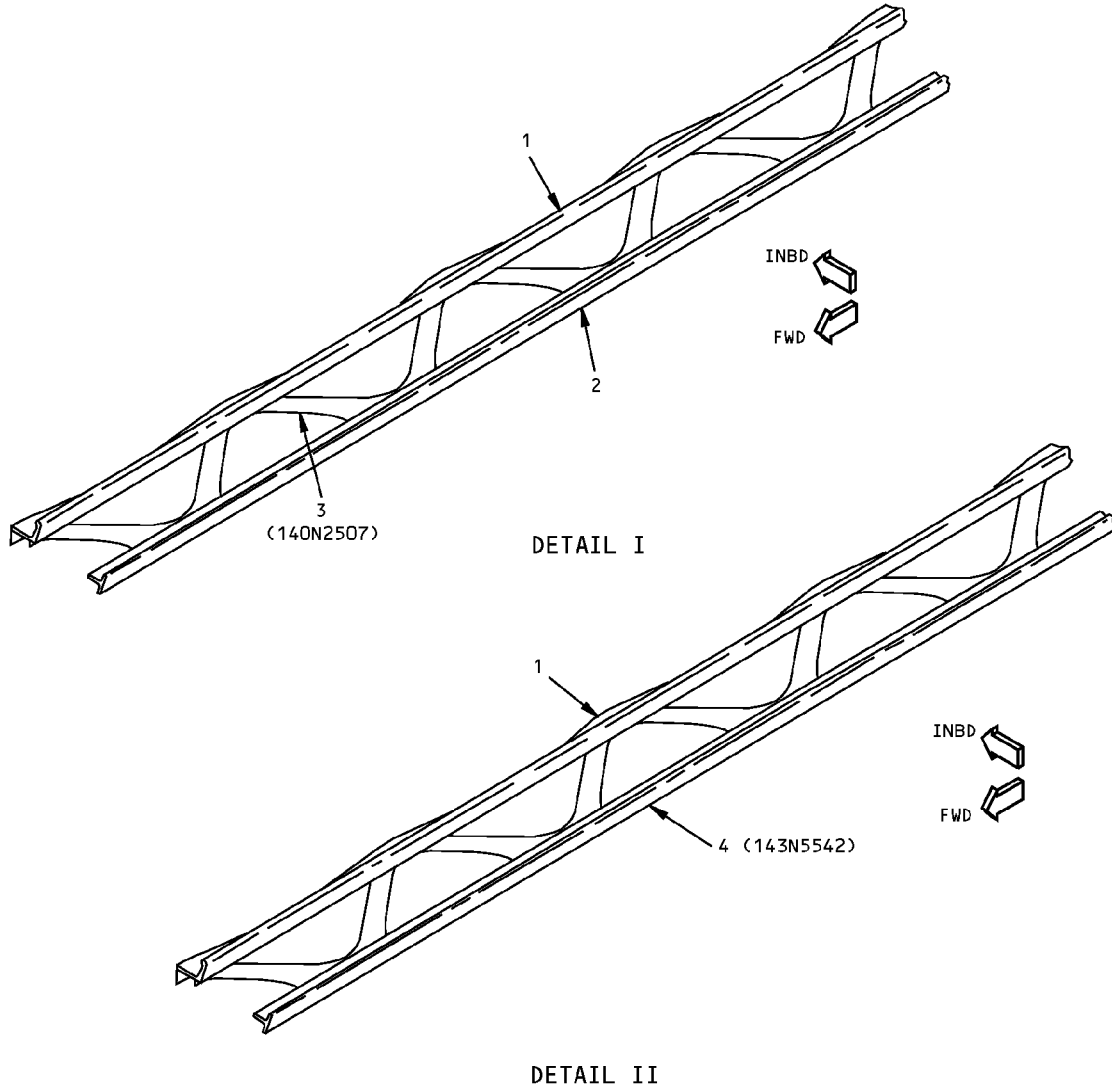
NOTES

- A** OPTIONAL USE FOR CUM LINE NUMBERS:
1 THRU 8

**Section 43 Crease Beam Identification
Figure 1 (Sheet 1 of 7)**

**757-200
STRUCTURAL REPAIR MANUAL**

REF DWG
143N5520



ITEM	DESCRIPTION	GAGE	MATERIAL	EFFECTIVITY
1	INBD CHORD		BAC1515-553 7075-T6511	
2	OUTBD CHORD		BAC1506-3406 2024-T3511	
3	TRUSS	0.080	CLAD 7075-T6	
4	OUTBD CHORD		BAC1506-1941 2024-T3511 BAC1506-1941 7075-T6511	A

LIST OF MATERIALS FOR DETAILS I AND II

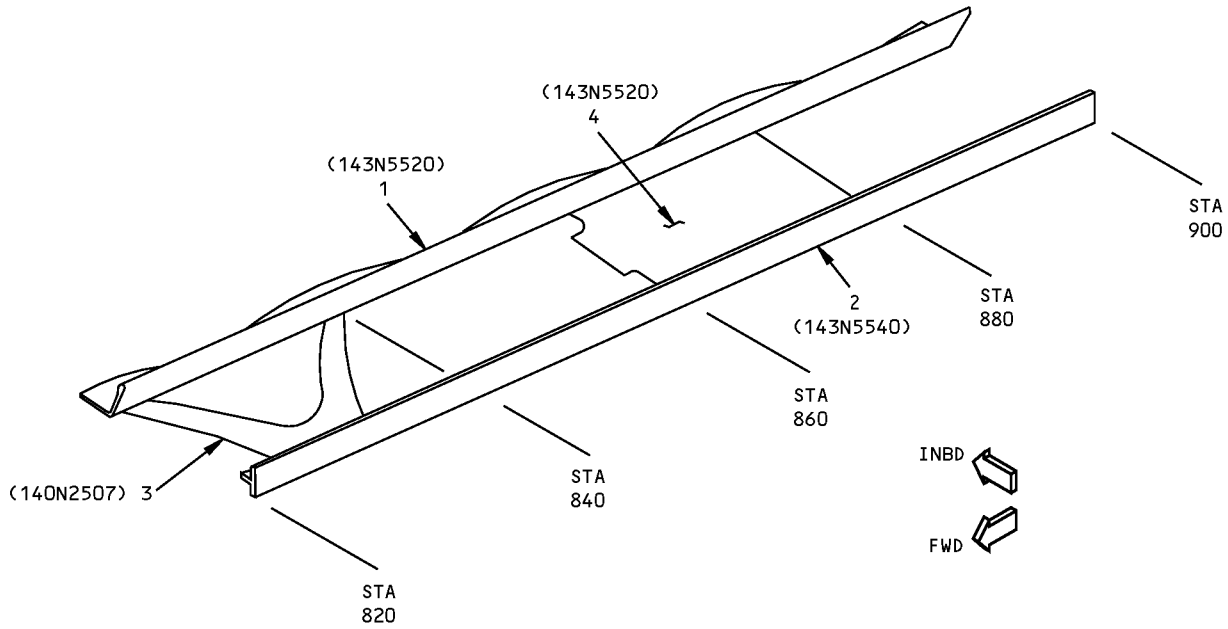
**Section 43 Crease Beam Identification
Figure 1 (Sheet 2 of 7)**

IDENTIFICATION 1
Page 2
Jan 20/2005

53-30-13

D634N201

**757-200
STRUCTURAL REPAIR MANUAL**



DETAIL III

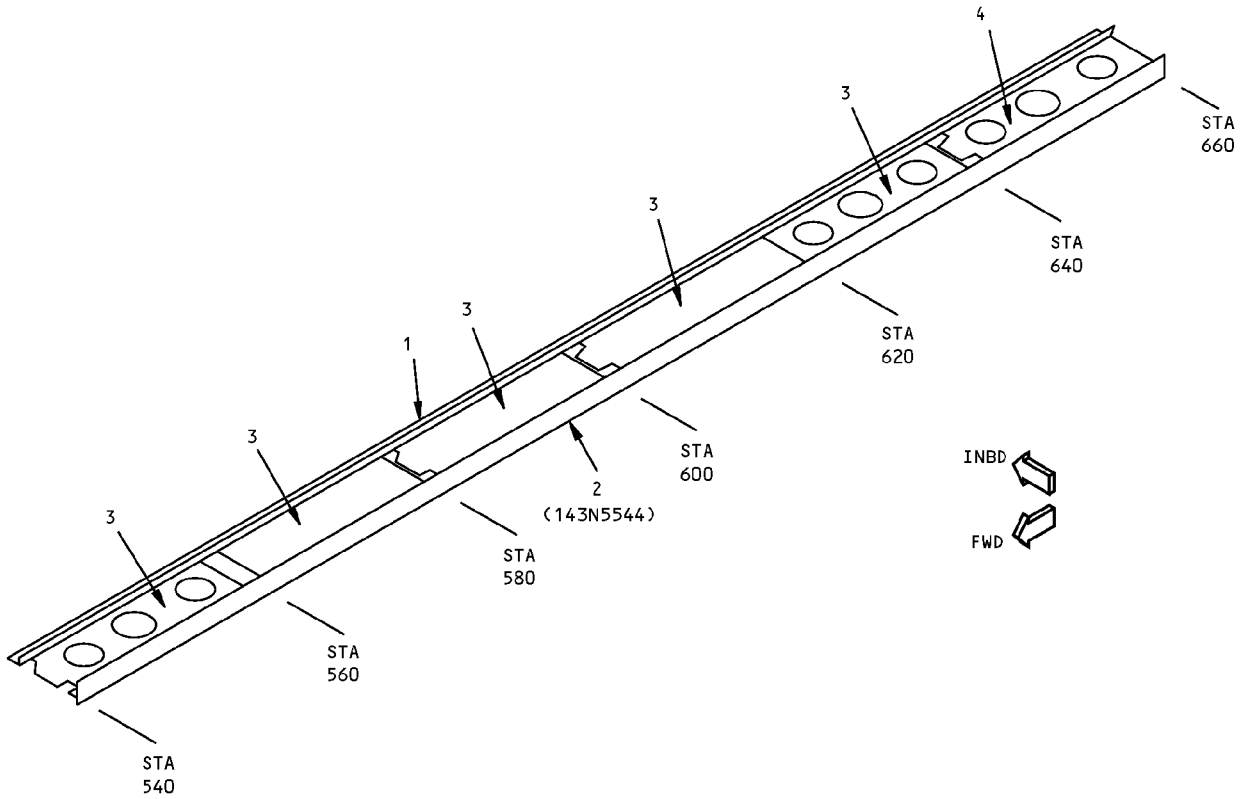
ITEM	DESCRIPTION	GAGE	MATERIAL	EFFECTIVITY
1	INBD CHORD		BAC1515-553 7075-T6511	
2	OUTBD CHORD		BAC1518-775 7075-T73511	
3	TRUSS	0.080	CLAD 7075-T6	
4	WEB	0.040	7075-T6	

LIST OF MATERIALS FOR DETAIL III

**Section 43 Crease Beam Identification
Figure 1 (Sheet 3 of 7)**

**757-200
STRUCTURAL REPAIR MANUAL**

REF DWG
143N5520



DETAIL IV

ITEM	DESCRIPTION	GAGE	MATERIAL	EFFECTIVITY
1	INBD CHORD		BAC1515-553 7075-T6511	
2	OUTBD CHORD		BAC1506-1903 7075-T6511	
3	WEB	0.036	7075-T6	
4	WEB	0.050	7075-T6	

LIST OF MATERIALS FOR DETAIL IV

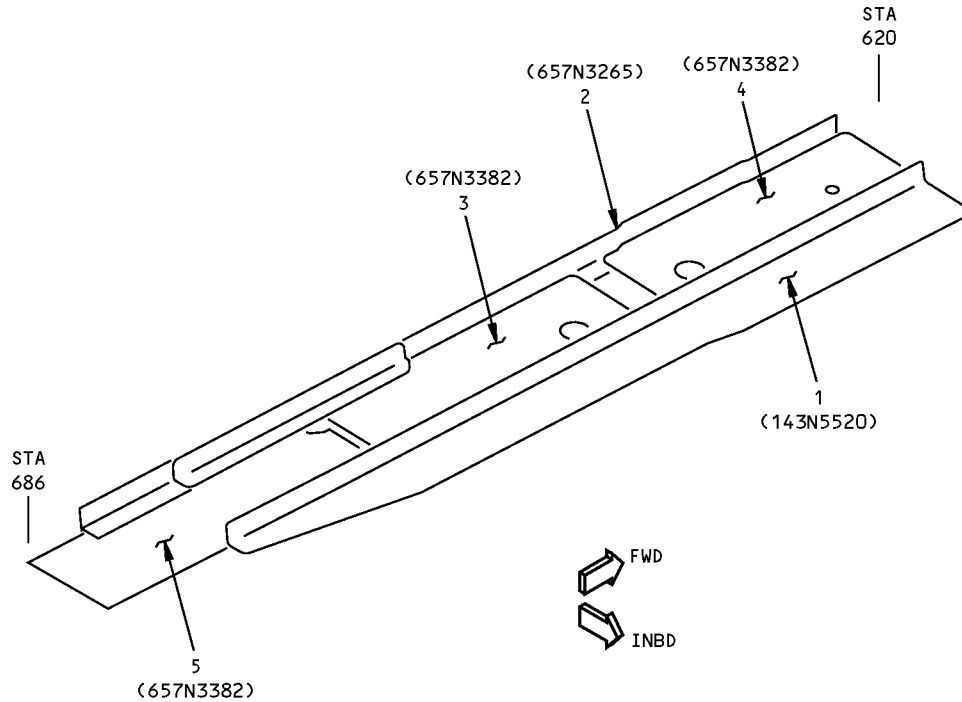
**Section 43 Crease Beam Identification
Figure 1 (Sheet 4 of 7)**

IDENTIFICATION 1
Page 4
Jan 20/2005

53-30-13

D634N201

**757-200
STRUCTURAL REPAIR MANUAL**



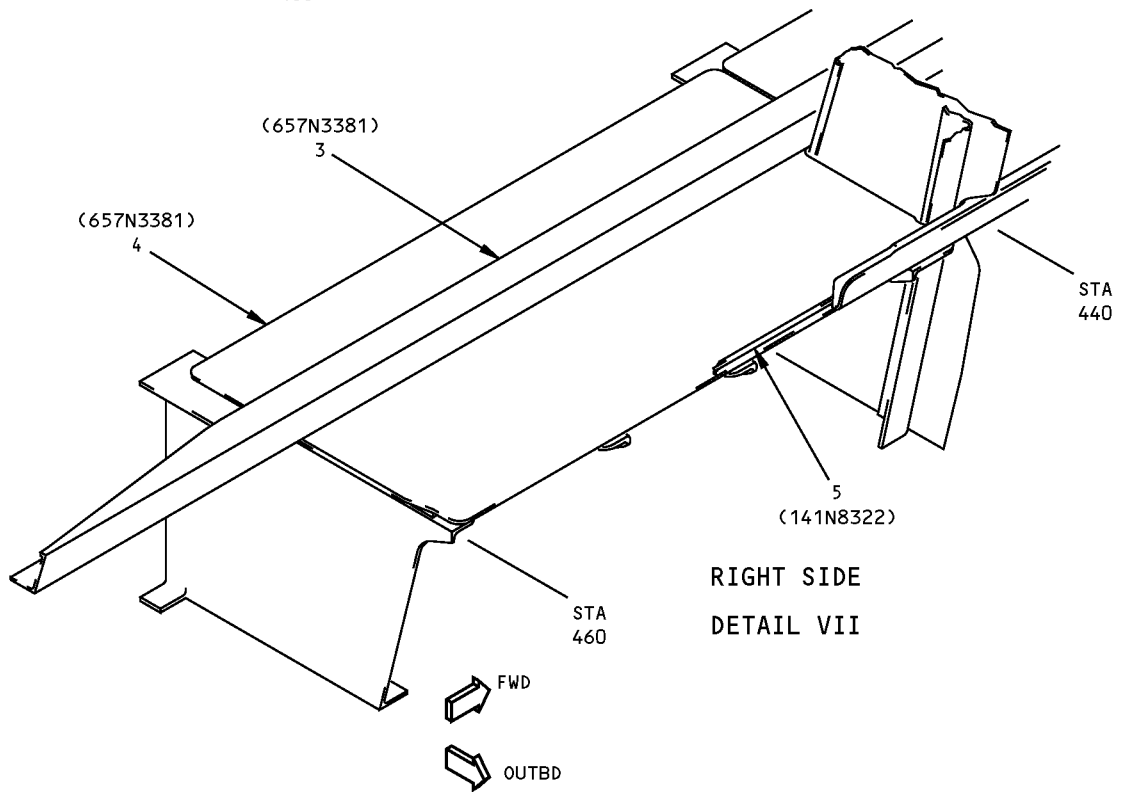
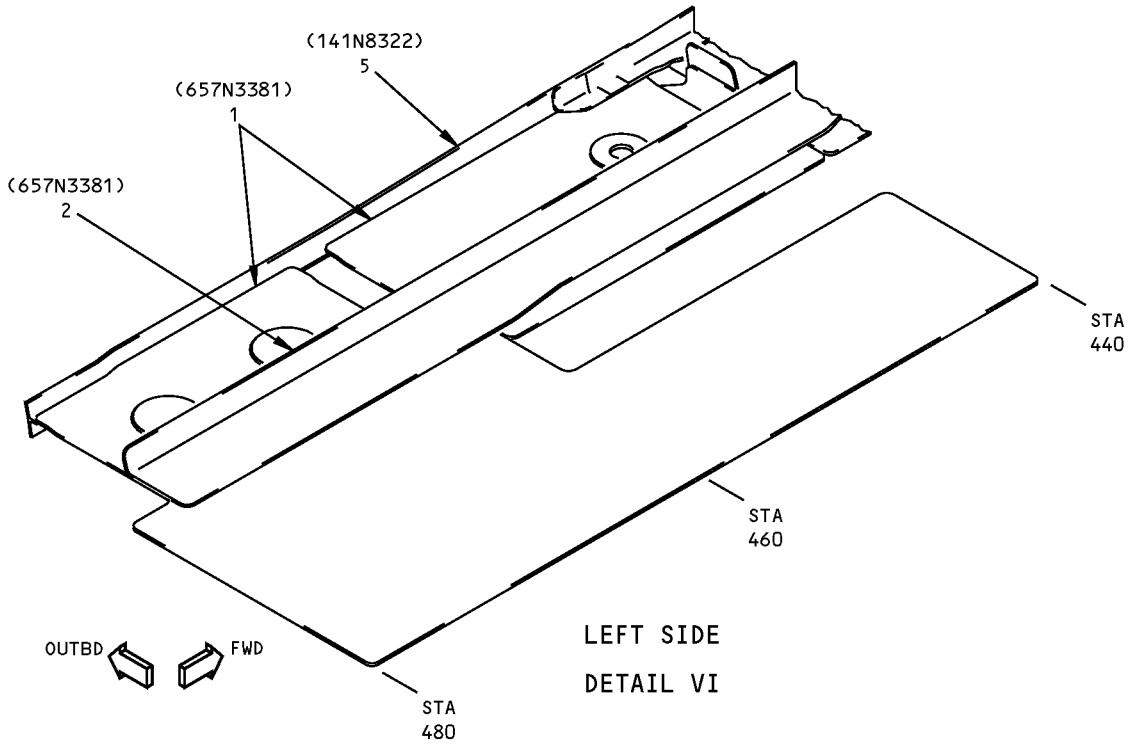
**MODIFIED CREASE BEAM FOR 757-SF AIRPLANES ONLY
DETAIL V**

ITEM	DESCRIPTION	GAGE	MATERIAL	EFFECTIVITY
1	INBOARD CHORD	0.100	7075-0 HT TR T6	
2	OUTBOARD CHORD		ALTER BAC 1506-1941 2024-T3511 EXTRUSION	
3	WEB	0.050	CLAD 7075-0 HT TR T62	
4	WEB	0.063	CLAD 7075-0 HT TR T62	
5	WEB	0.071	CLAD 7075-0 HT TR T62	

LIST OF MATERIALS FOR DETAIL V

**Section 43 Crease Beam Identification
Figure 1 (Sheet 5 of 7)**

**757-200
STRUCTURAL REPAIR MANUAL**



**Section 43 Crease Beam Identification
Figure 1 (Sheet 6 of 7)**



757-200
STRUCTURAL REPAIR MANUAL

ITEM	DESCRIPTION	GAGE	MATERIAL	EFFECTIVITY
1	WEB	0.100	7075-T62 CLAD	
2	INNER CHORD	0.100	7075-T62 CLAD	
3	INNER CHORD	0.071	7075-T62 CLAD	
4	WEB	0.100	7075-T62 CLAD	
5	OUTER CHORD		BAC1506-2668 2024-T42	

LIST OF MATERIALS FOR DETAIL VI AND VII

Section 43 Crease Beam Identification
Figure 1 (Sheet 7 of 7)

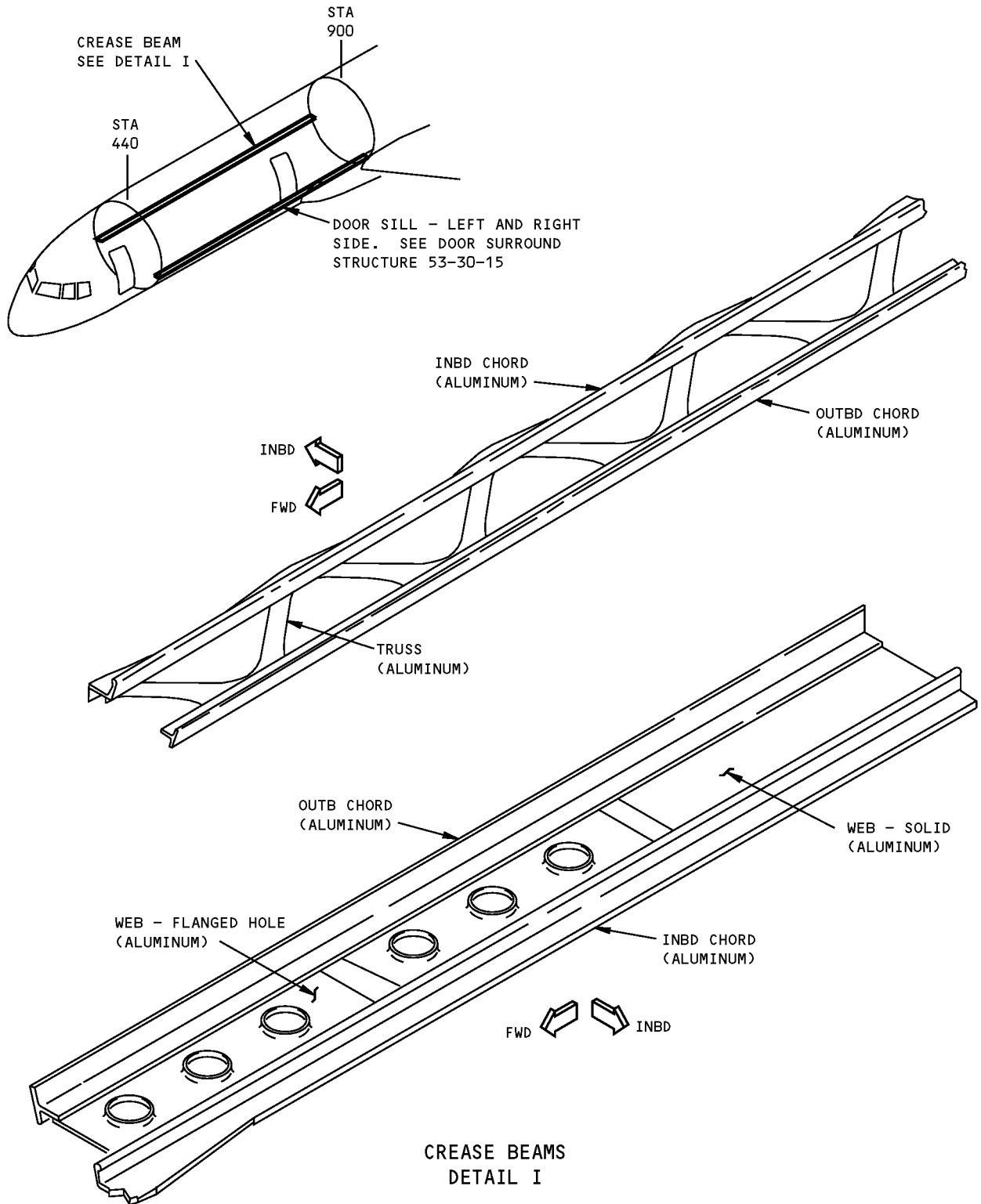
D634N201

53-30-13

IDENTIFICATION 1
Page 7
Jan 20/2005

**757-200
STRUCTURAL REPAIR MANUAL**

ALLOWABLE DAMAGE 1 - SECTION 43 - CREASE BEAM



**Section 43 Crease Beam Allowable Damage
Figure 101 (Sheet 1 of 5)**

**757-200
STRUCTURAL REPAIR MANUAL**

DESCRIPTION	CRACKS	NICKS, GOUGES AND CORROSION	DENTS	HOLES AND PUNCTURES
WEBS - SOLID	[B]	[A]	SEE DETAIL IV	[D]
WEBS - FLANGED HOLE	[B]	[C]	SEE DETAIL IV	[D]
CHORD - INBOARD	[G]	SEE DETAIL VIII	NOT PERMITTED	NOT PERMITTED
CHORD - OUTBOARD	[H]	[F]	NOT PERMITTED	NOT PERMITTED
TRUSS	[E]	[J]	NOT PERMITTED	[K]

NOTES

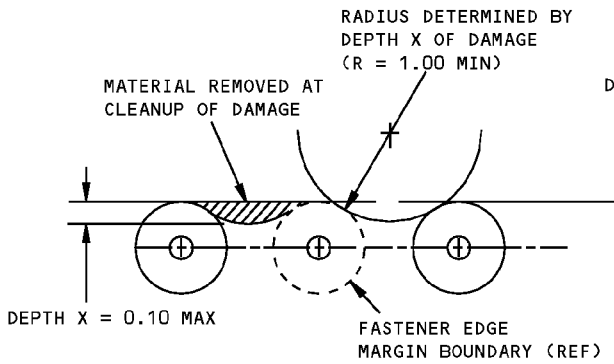
- THIS ALLOWABLE DAMAGE IS A CATEGORY A REPAIR FOR 757-SF AIRPLANES. THE INSPECTIONS GIVEN IN THE MAINTENANCE PLANNING DATA (MPD) AND ASSOCIATED SUPPLEMENT ARE SUFFICIENT TO MAINTAIN THE DAMAGE TOLERANCE OF THE INITIAL STRUCTURE WITH THIS ALLOWABLE DAMAGE. REFER TO SRM 51-00-06 FOR REPAIR CATEGORIES AND DEFINITIONS.
- REFER TO IDENTIFICATION 1 FOR CREASE BEAM LOCATIONS.
- REFINISH REWORKED AREAS AS GIVEN IN AMM 51-20.
- REFER TO SRM 51-10-02 FOR INSPECTION AND REMOVAL OF DAMAGE

- [A] REMOVE DAMAGE AS SHOWN IN DETAILS II, III, AND V
- [B] FOR EDGE CRACKS SEE DETAILS II AND V. FOR LIGHTENING HOLE EDGE CRACKS SEE DETAIL VI
- [C] REMOVE DAMAGE AS SHOWN IN DETAILS III, V, AND VI
- [D] CLEAN OUT DAMAGE UP TO 0.25 INCH (6 mm) MAX DIA AND NOT CLOSER THAN 1.5 INCH (38 mm) TO FASTENER HOLE, MATERIAL EDGE, OR OTHER DAMAGE. FILL HOLE WITH 2117-T3 OR T4 ALUMINUM RIVET INSTALLED WET WITH BMS 5-95 SEALANT. ALL OTHER HOLES TO BE REPAIRED
- [E] CRACKS NOT PERMITTED EXCEPT FOR EDGE CRACKS WHICH CAN BE REMOVED AS SHOWN IN DETAILS II AND V

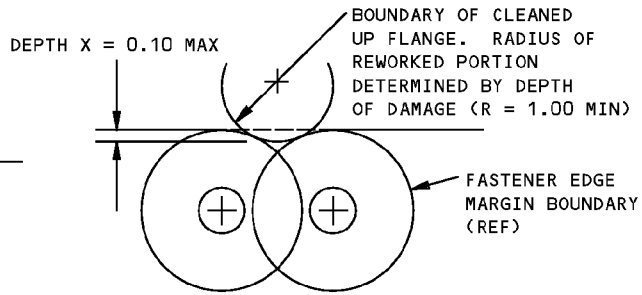
- [F] REMOVE DAMAGE AS SHOWN IN DETAILS II AND III
- [G] CRACKS NOT PERMITTED EXCEPT FOR EDGE CRACKS WHICH MUST BE REMOVED AS SHOWN IN DETAILS II AND VII
- [H] CRACKS NOT PERMITTED EXCEPT FOR EDGE CRACKS WHICH MUST BE REMOVED AS SHOWN IN DETAILS II AND III
- [J] REMOVE EDGE DAMAGE AS SHOWN IN DETAILS II AND V. BLEND OUT SURFACE DAMAGE AS SHOWN IN DETAIL VII
- [K] CLEAN OUT DAMAGE TO WEB PORTION OF TRUSS ONLY UP TO 0.25 INCH (6 mm) DIA AND NOT CLOSER THAN 1.0 INCH (25 mm) TO FASTENER HOLE, MATERIAL EDGE, OR OTHER DAMAGE. FILL HOLE WITH 2117-T3 OR T4 ALUMINUM RIVET INSTALLED WET WITH BMS 5-95 SEALANT. ALL OTHER HOLES TO BE REPAIRED

**Section 43 Crease Beam Allowable Damage
Figure 101 (Sheet 2 of 5)**

**757-200
STRUCTURAL REPAIR MANUAL**

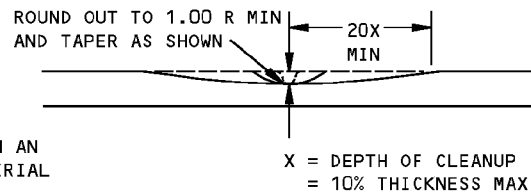
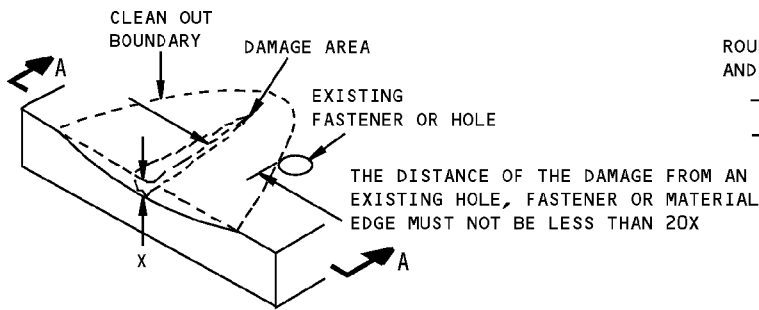


DAMAGE CLEANUP OF EDGES WHERE FASTENER EDGE MARGINS DO NOT OVERLAP



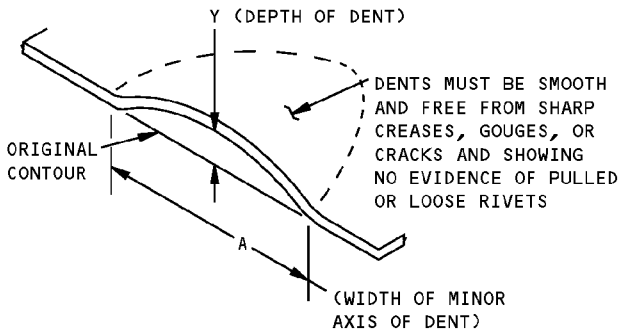
DAMAGE CLEANUP OF EDGES WHERE FASTENER EDGE MARGINS OVERLAP

DETAIL II



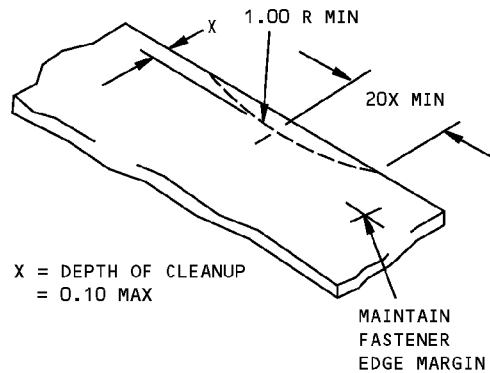
SECTION A-A

**REMOVAL OF NICK, GOUGE AND SCRATCH DAMAGE ON A SURFACE
DETAIL III**



$\frac{A}{Y}$ MUST NOT BE LESS THAN 30
Y (MAX) = 0.125

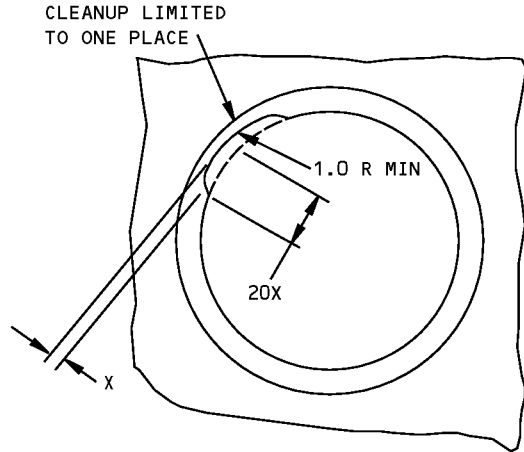
**ALLOWABLE DAMAGE FOR DENT
DETAIL IV**



**REMOVAL OF NICK OR CRACK
DAMAGE ON AN EDGE
DETAIL V**

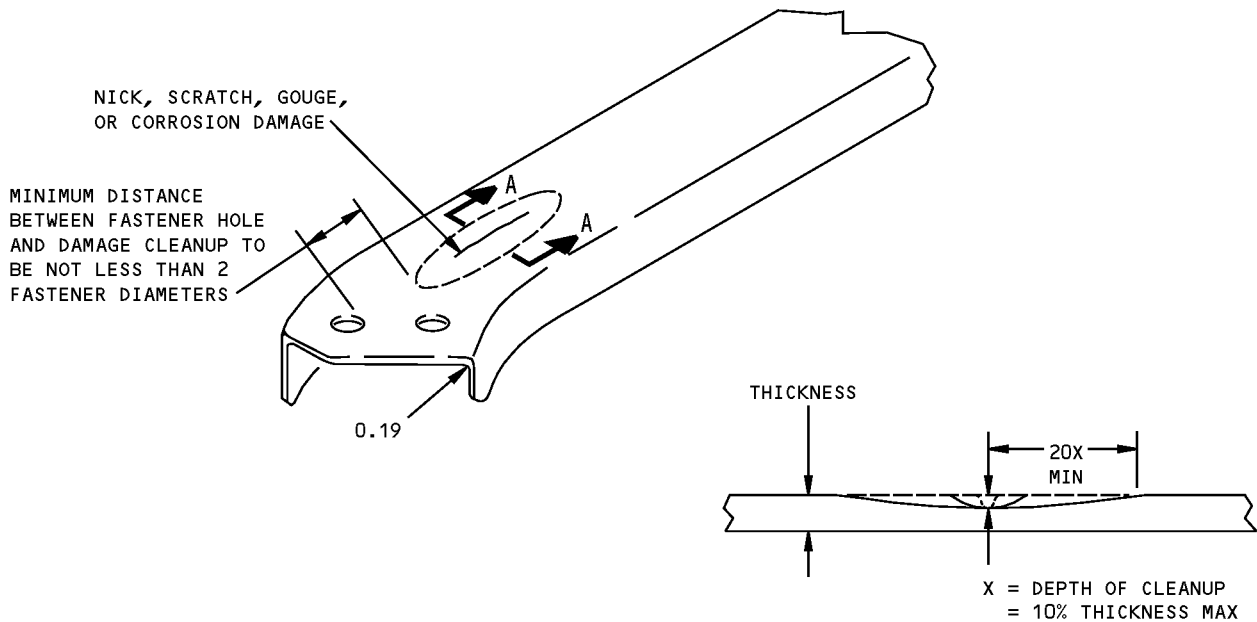
**Section 43 Crease Beam Allowable Damage
Figure 101 (Sheet 3 of 5)**

STRUCTURAL REPAIR MANUAL



X = DEPTH OF CLEANUP = 0.10 MAX OR
1/2 FLANGE WIDTH WHICHEVER IS LESS

**FLANGED HOLE EDGE DAMAGE CLEANUP
DETAIL VI**

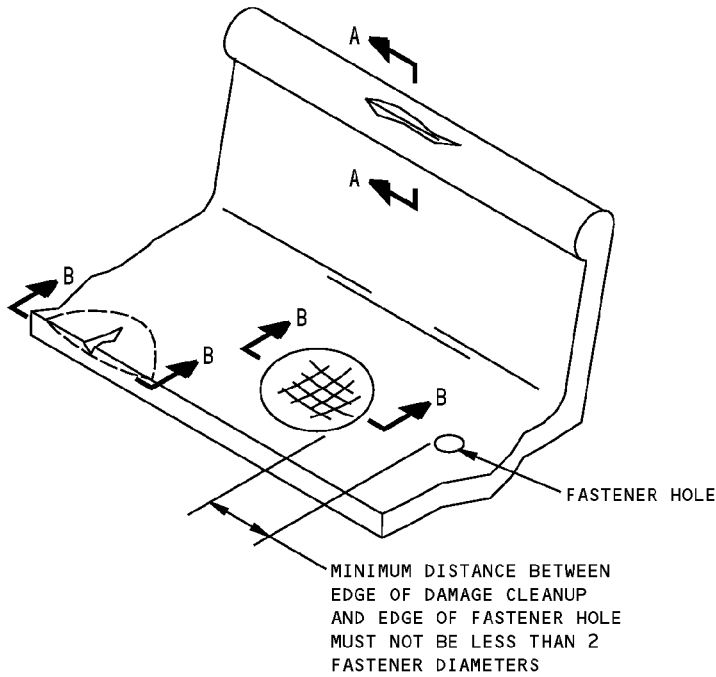


SECTION A-A

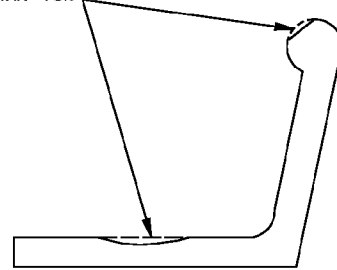
**NICK, GOUGE, AND SCRATCH REMOVAL
FROM SURFACE OF CREASE BEAM TRUSS
DETAIL VII**

**Section 43 Crease Beam Allowable Damage
Figure 101 (Sheet 4 of 5)**

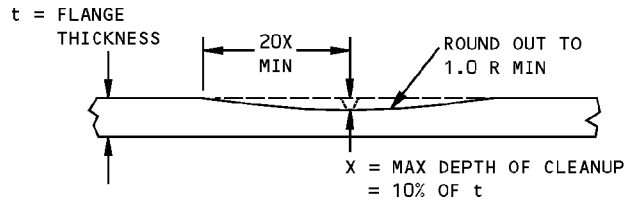
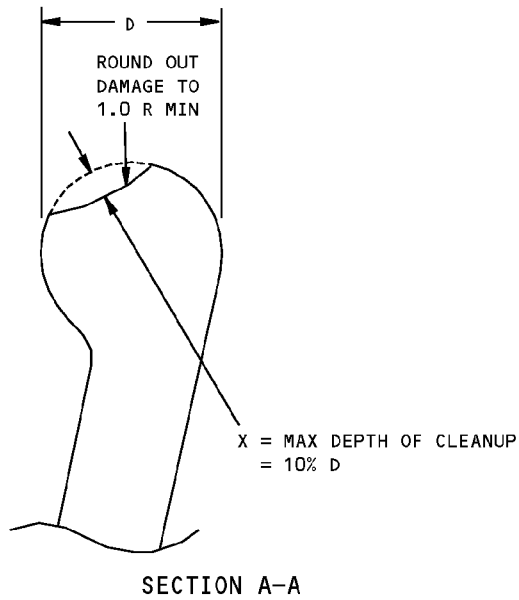
**757-200
STRUCTURAL REPAIR MANUAL**



DAMAGE CLEANUP MUST NOT
REDUCE CROSS-SECTIONAL
AREA BY MORE THAN 10%



SECTION THRU EXTRUSION



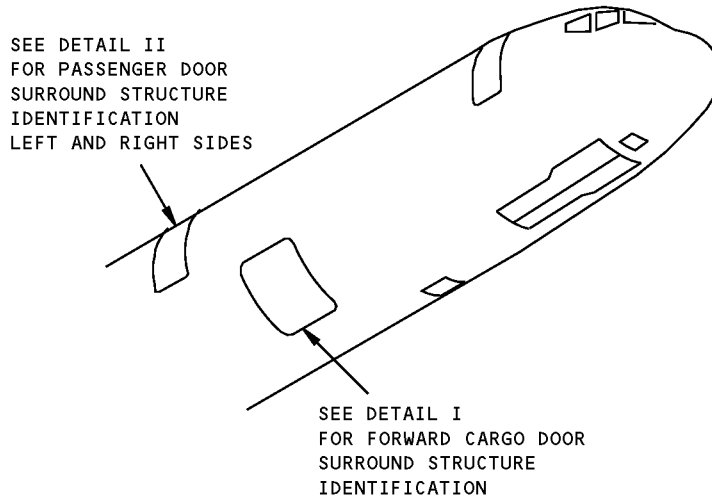
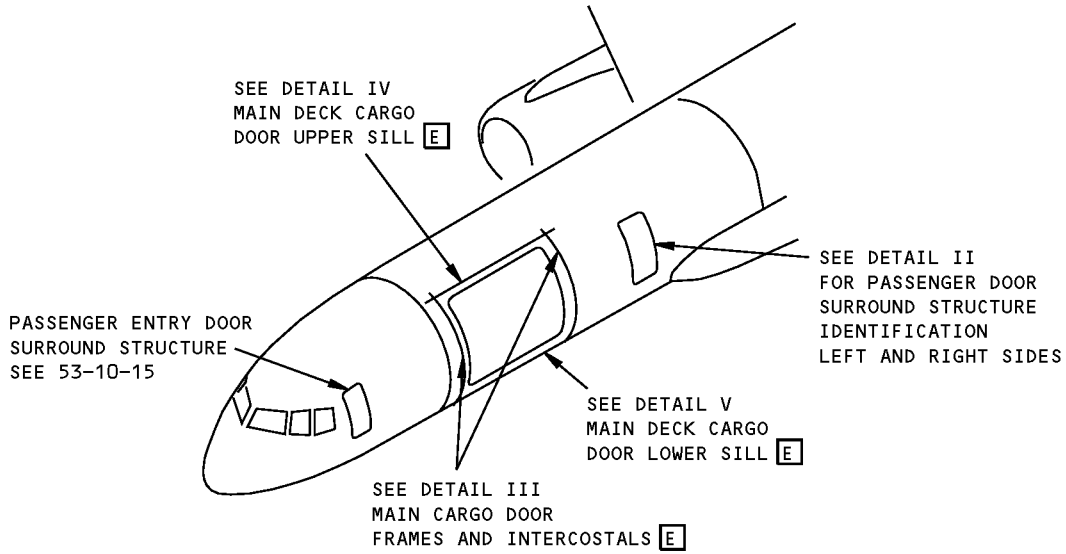
SECTION B-B

**DAMAGE CLEANUP OF BULB ANGLE
DETAIL VIII**

**Section 43 Crease Beam Allowable Damage
Figure 101 (Sheet 5 of 5)**

**757-200
STRUCTURAL REPAIR MANUAL**

IDENTIFICATION 1 - SECTION 43 - DOOR SURROUND STRUCTURE



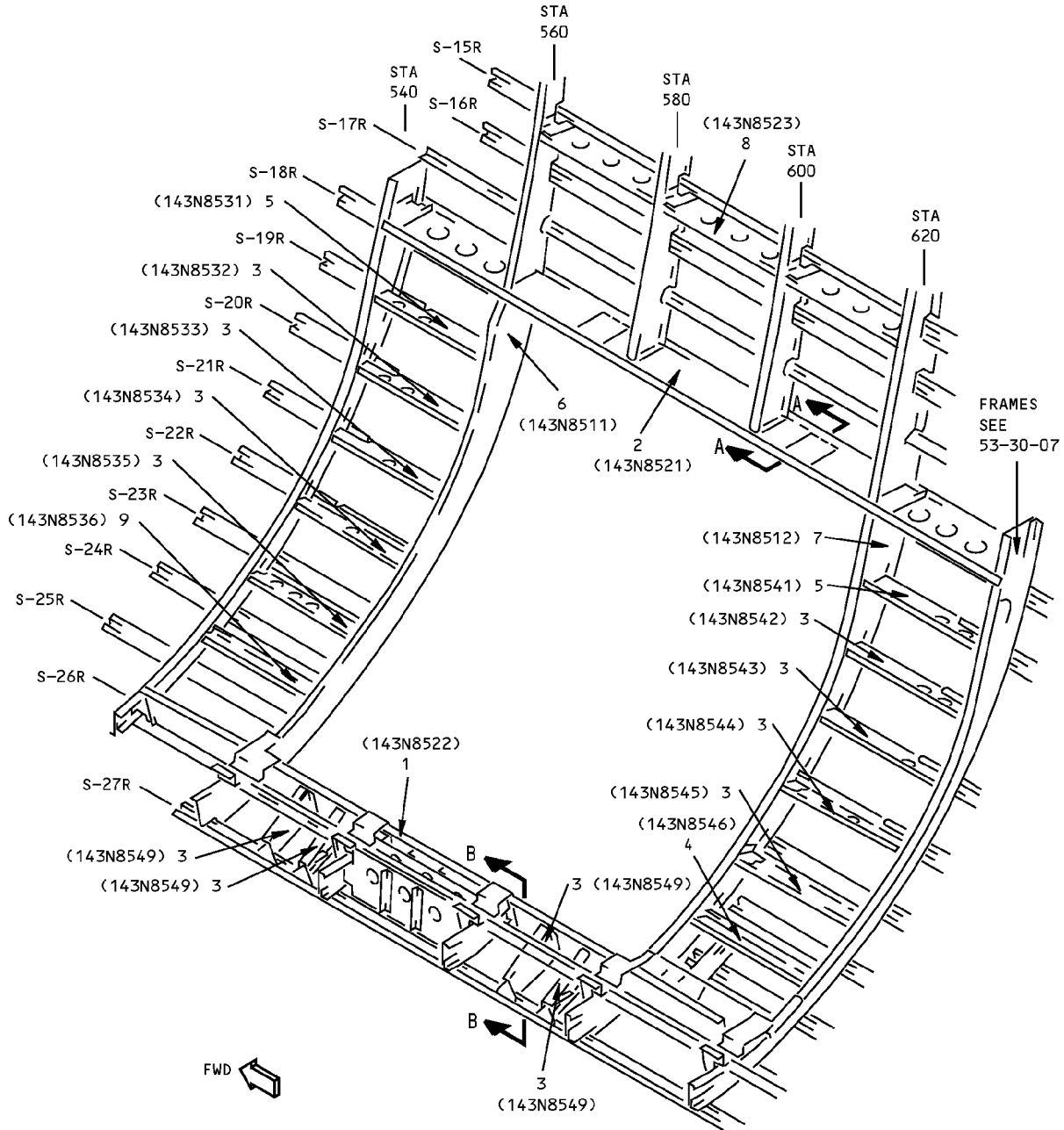
NOTES

- [A] FOR CUM LINE NUMBERS:
1 THRU 56, 61
- [B] FOR ALL AIRPLANES NOT IN [A]
- [C] FOR CUM LINE NUMBERS:
1 THRU 92, 94 AND 95
- [D] FOR ALL AIRPLANES NOT IN [C]
- [E] FOR 757-SF AIRPLANES ONLY

**Section 43 Door Surround Structure Identification
Figure 1 (Sheet 1 of 9)**

**757-200
STRUCTURAL REPAIR MANUAL**

REF DWG
143N0212



**FORWARD CARGO COMPARTMENT DOOR SURROUND STRUCTURE
DETAIL I**

LIST OF
MATERIAL

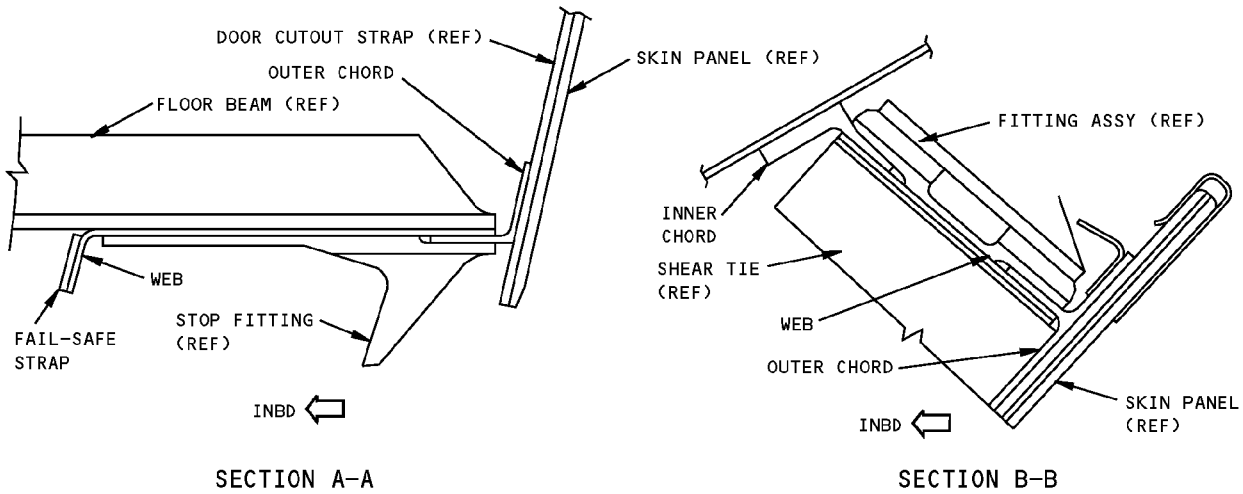
**Section 43 Door Surround Structure Identification
Figure 1 (Sheet 2 of 9)**

IDENTIFICATION 1
Page 2
Jan 20/2005

53-30-15

D634N201

**757-200
STRUCTURAL REPAIR MANUAL**



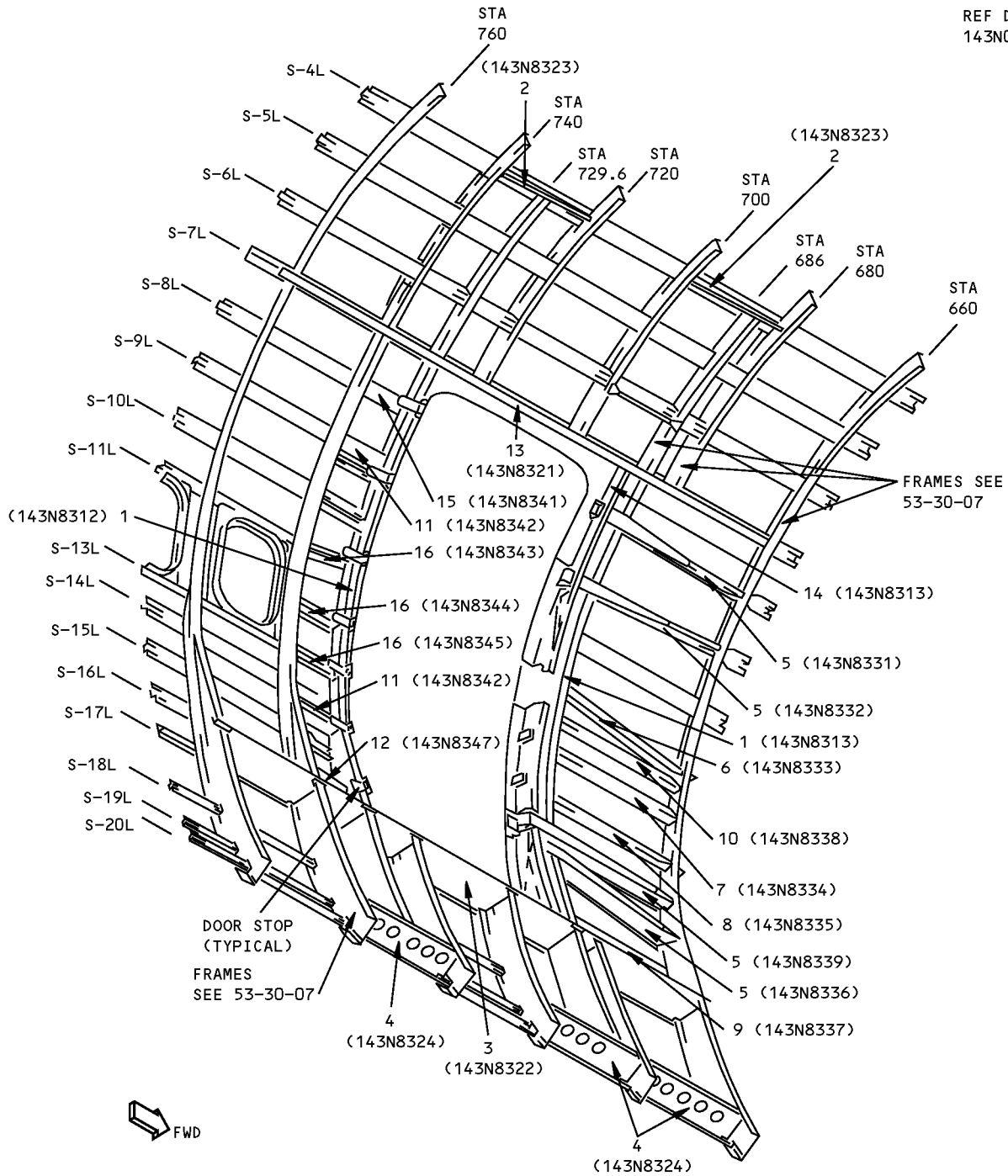
ITEM	DESCRIPTION	GAGE	MATERIAL	EFFECTIVITY
1	LWR SILL WEB OUTER CHORD INNER CHORD	0.071	7075-T6 AND10136-3001 7075-T73511 BAC1514-1784 7075-T3511	
2	UPR SILL WEB WEB OUTER CHORD FAIL-SAFE STRAP	0.071 0.063 0.020	7075-T6 7075-T6 BAC1514-2648 7075-T73511 7075-T6	
3	INTERCOSTAL	0.050	CLAD 7075-T6	
4	INTERCOSTAL	0.080	2024-T42	
5	INTERCOSTAL	0.056	2024-T42	
6	FWD ASSY WEB WEB WEB OUTER CHORD OUTER CHORD INNER CHORD INNER CHORD	0.071 0.056 0.080	7075-T6 CLAD 7075-T6 2024-T3 BAC1503-100275 7075-T73 BAC1503-100275 2024-T42 BAC1505-100849 7075-T73 BAC1505-100849 2024-T42	<input type="checkbox"/> <input type="checkbox"/> <input type="checkbox"/> <input type="checkbox"/> <input type="checkbox"/> <input type="checkbox"/>
7	AFT FRAME WEB WEB OUTER CHORD OUTER CHORD INNER CHORD INNER CHORD	0.071 0.080	7075-T6 2024-T3 BAC1503-100275 7075-T73 BAC1503-100275 2024-T42 BAC1503-100698 7075-T73 BAC1505-100849 2024-T42	<input type="checkbox"/> <input type="checkbox"/> <input type="checkbox"/> <input type="checkbox"/>
8	AUX SILL WEB	0.040	CLAD 7075-T6	
9	INTERCOSTAL WEB ANGLE	0.080	2024-T42 AND10134-1006 2024-T3511	<input type="checkbox"/>

LIST OF MATERIALS FOR DETAIL I

**Section 43 Door Surround Structure Identification
Figure 1 (Sheet 3 of 9)**

**757-200
STRUCTURAL REPAIR MANUAL**

REF DWG
143N0300



LEFT SIDE SHOWN
RIGHT SIDE OPPOSITE
PASSENGER DOOR SURROUND STRUCTURE IDENTIFICATION
DETAIL II

**Section 43 Door Surround Structure Identification
Figure 1 (Sheet 4 of 9)**

LIST OF
MATL

IDENTIFICATION 1
Page 4
Jan 20/2005

53-30-15

D634N201



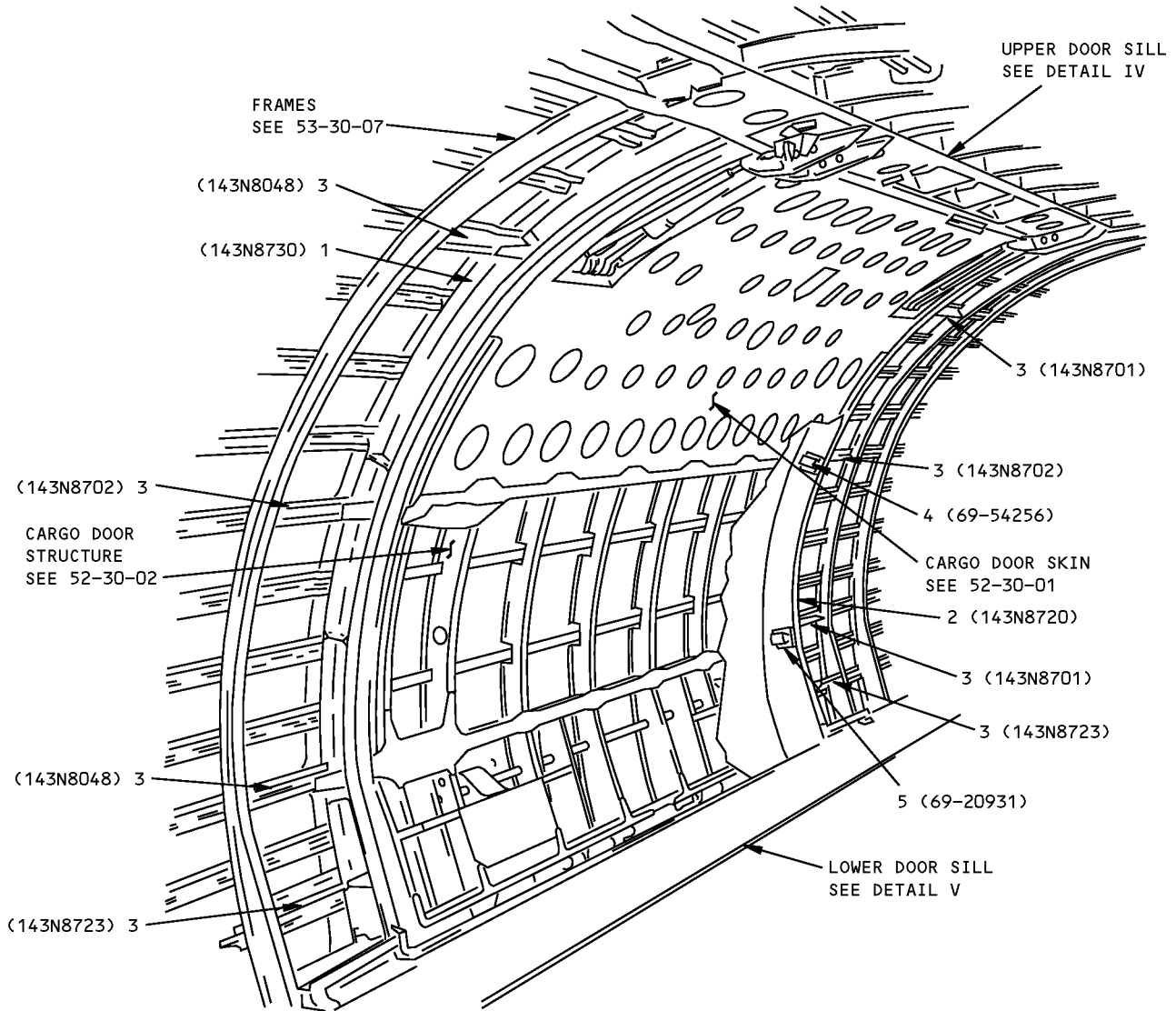
**757-200
STRUCTURAL REPAIR MANUAL**

ITEM	DESCRIPTION	GAGE	MATERIAL	EFFECTIVITY
1	FRAME OUTER CHORD WEB	0.080	BAC1503-100674 7075-T73 7075-T6	
2	UPR AUX SILL WEB WEB	0.056 0.040	CLAD 7075-T6 CLAD 7075-T6	
3	LWR MAIN SILL OUTER CHORD WEB WEB INNER CHORD	0.071 0.056 0.080	BAC1506-1651 7075-T73511 OPT BAC1506-2667 7075-T73 7075-T6 CLAD 7075-T6 7075-T6	
4	LWR AUX SILL WEB WEB	0.050 0.056	CLAD 7075-T6 CLAD 7075-T6	
5	INTERCOSTAL WEB OUTER CHORD	0.045	CLAD 7075-T6 BAC1500-6238 CLAD 7075-T6	
6	INTERCOSTAL WEB OUTER CHORD	0.045	CLAD 7075-T6 BAC1503-100502 7075-T6511	
7	INTERCOSTAL WEB	0.056	CLAD 7075-T6	
8	INTERCOSTAL WEB OUTER CHORD	0.056	CLAD 7075-T6 BAC1503-100502 7075-T6511	
9	INTERCOSTAL WEB OUTER CHORD	0.045 0.071	CLAD 7075-T6 7075-T6	
10	INTERCOSTAL WEB	0.045	CLAD 7075-T6	
11	INTERCOSTAL WEB WEB	0.032 0.050	CLAD 7075-T6 CLAD 2024-T42	
12	INTERCOSTAL	0.045	CLAD 2024-T6	
13	UPR MAIN SILL OUTER CHORD WEB WEB STRAP	0.063 0.045 0.300	BAC1506-928 7075-T73511 CLAD 7075-T6 CLAD 7075-T6 2024-T351	
14	FRAME UPR WEB CENTER WEB LWR WEB	0.063 0.050 0.063	CLAD 7075-T6 CLAD 7075-T6 CLAD 7075-T6	
15	INTERCOSTAL WEB WEB	0.045 0.045	CLAD 7075-T6 CLAD 2024-T42	C D
16	INTERCOSTAL WEB WEB	0.032 0.040	CLAD 7075-T6 2024-T42	C D

LIST OF MATERIALS FOR DETAIL II

**Section 43 Door Surround Structure Identification
Figure 1 (Sheet 5 of 9)**

**757-200
STRUCTURAL REPAIR MANUAL**



**MAIN CARGO DOOR
DETAIL III E**



**Section 43 Door Surround Structure Identification
Figure 1 (Sheet 6 of 9)**



757-200
STRUCTURAL REPAIR MANUAL

ITEM	DESCRIPTION	GAGE	MATERIAL	EFFECTIVITY
1	AFT DOOR FRAME ASSY UPPER FRAME LOWER FRAME	3.0	BAC1509-100210 7075-T73 7075-T7351	
2	FWD FRAME ASSY UPPER FRAME LOWER FRAME	3.0	BAC1509-100210 7075-T73 (OPTIONAL: BAC1509-100269 7075-T73) 7075-T7351	
3	INTERCOSTAL	0.063	CLAD 2024-T42	
4	STOP FITTING (S-10)	2.25	7075-T7351	
5	STOP FITTING (S-6 AND S-14)	2.25	2024-T4	

LIST OF MATERIALS FOR DETAIL III

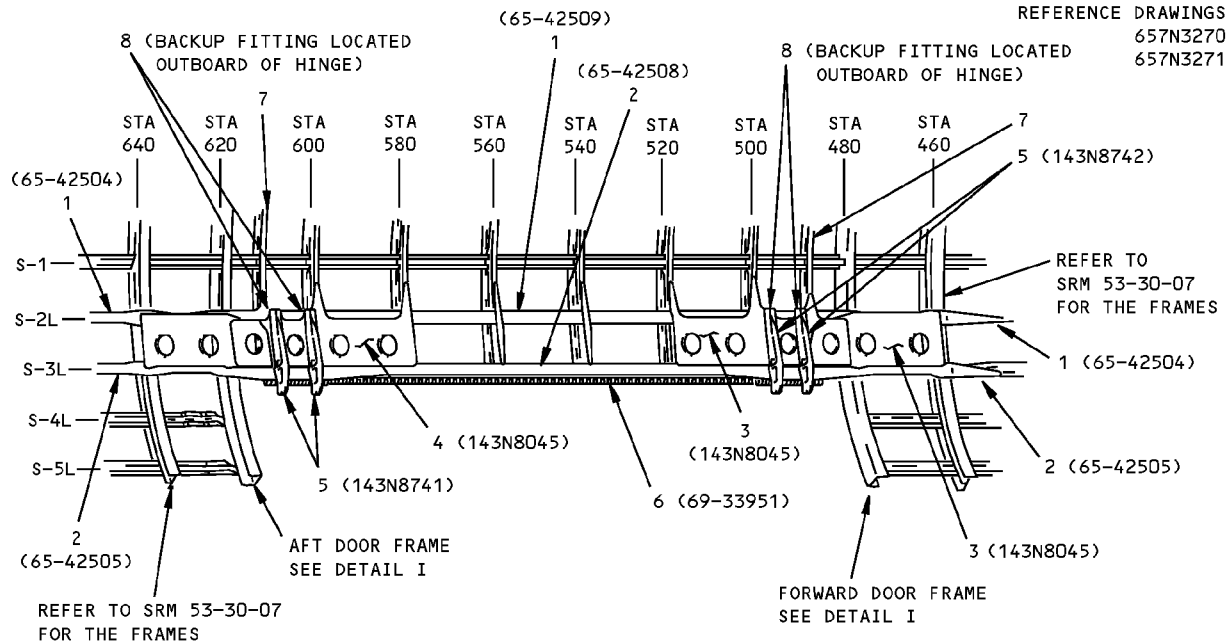
Section 43 Door Surround Structure Identification
Figure 1 (Sheet 7 of 9)

D634N201

53-30-15

IDENTIFICATION 1
Page 7
Jan 20/2005

**757-200
STRUCTURAL REPAIR MANUAL**



**MAIN CARGO DOOR
UPPER SILL
DETAIL IV [E]**

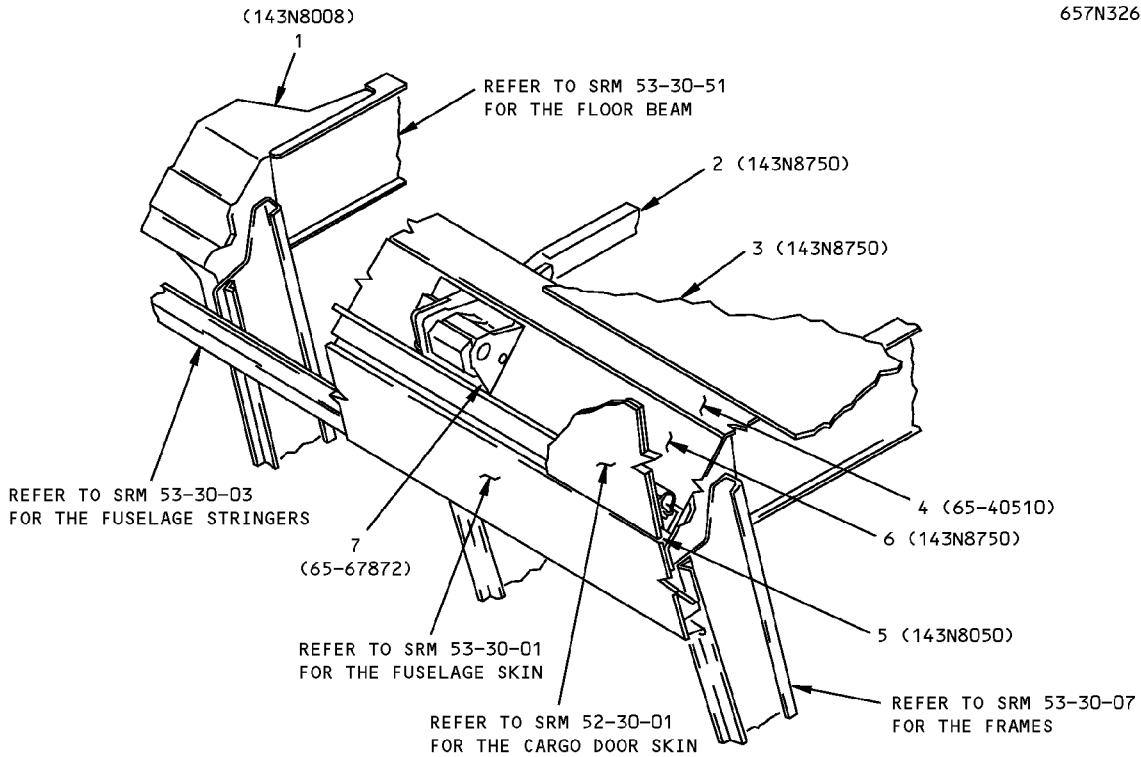
ITEM	DESCRIPTION	GAGE	MATERIAL	EFFECTIVITY
1	BEAM ASSEMBLY OUTER CHORD INNER CHORD WEB	0.050	BAC1506-1696 2024-T3511 BAC1506-1695 2024-T3511 CLAD 2024-T3	
2	BEAM ASSEMBLY OUTER CHORD INNER CHORD WEB	0.050	BAC1514-1659 2024-T3511 BAC1506-1711 2024-T3511 CLAD 2024-T3	
3	CLOSURE WEB	0.050	CLAD 2024-T3	
4	CLOSURE WEB	0.045	CLAD 2024-T3	
5	HINGE	0.080	CRES 15-5PH HT TR 150-170 KSI	
6	HINGE		FORGING 4330M STEEL HT TR 180-200 KSI	
7	BACKUP RIB ASSEMBLY (S-2R TO S-2L) RIB SHEAR TIE	0.063 0.063	CLAD 2024-T42 CLAD 2024-T42	
8	BACKUP RIB ASSEMBLY (S-2L to S-3L) RIB CHORD		FORGING 7075-T73 BAC1505-100505 2024-T3511	

LIST OF MATERIALS FOR DETAIL IV

**Section 43 Door Surround Structure Identification
Figure 1 (Sheet 8 of 9)**

**757-200
STRUCTURAL REPAIR MANUAL**

REFERENCE DRAWING
657N3260



**MAIN CARGO DOOR
LOWER DOOR SILL
DETAIL V E**

ITEM	DESCRIPTION	GAGE	MATERIAL	EFFECTIVITY
1	LATCH SUPPORT FITTING		FORGING 7075-T73	
2	CHANNEL		BAC1509-13703 7075-T6511	
3	SHEAR WEB	0.063	CLAD 7075-T6	
4	INNER CHORD		BAC1508-146 7075-T73511	
5	OUTER CHORD		BAC1514-1656 2024-T3511	
6	WEB ASSEMBLY			
	WEB	0.050	CLAD 2024-T3	
	DOUBLER	0.032	CLAD 2024-T3	
7	LATCH FITTING		4340 STEEL FORGING HT TR 180-200 KSI	

LIST OF MATERIALS FOR DETAIL V

**Section 43 Door Surround Structure Identification
Figure 1 (Sheet 9 of 9)**

IDENTIFICATION 1
Page 9
Jan 20/2005

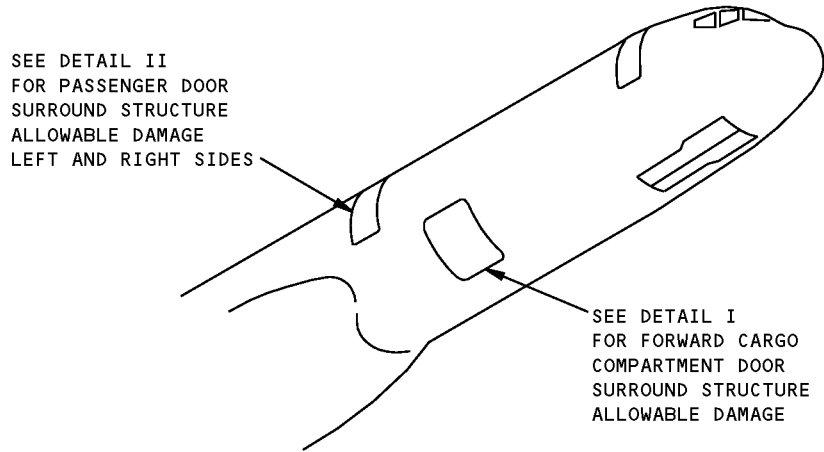
53-30-15

D634N201



757-200
STRUCTURAL REPAIR MANUAL

ALLOWABLE DAMAGE 1 - SECTION 43 - DOOR SURROUND STRUCTURE



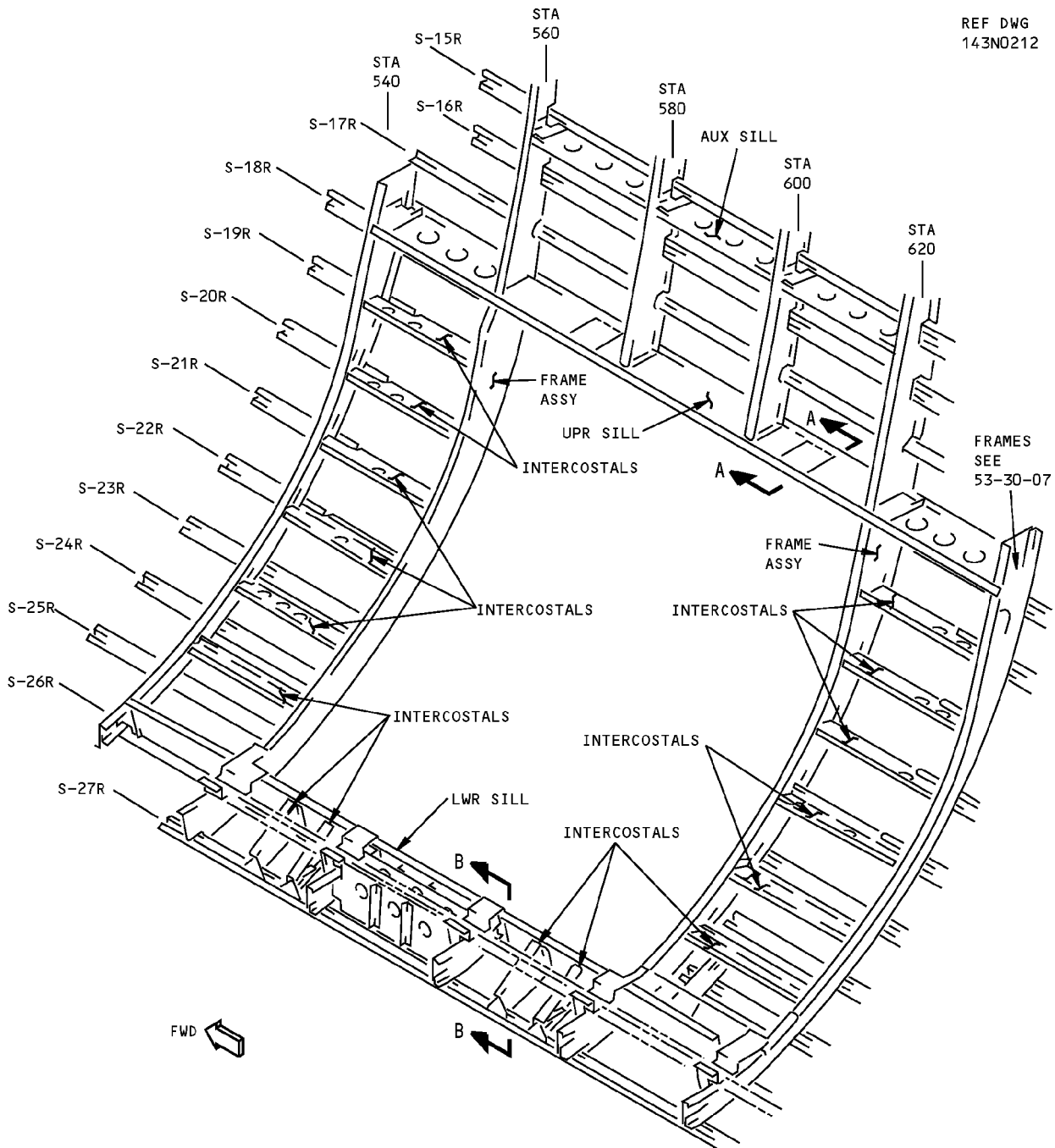
Section 43 Door Surround Structure Allowable Damage
Figure 101 (Sheet 1 of 7)

D634N201

ALLOWABLE DAMAGE 1
Page 101
53-30-15 Jan 20/2005

**757-200
STRUCTURAL REPAIR MANUAL**

REF DWG
143N0212



**FORWARD CARGO COMPARTMENT DOOR SURROUND STRUCTURE
DETAIL I**

MATERIAL: ALUMINUM

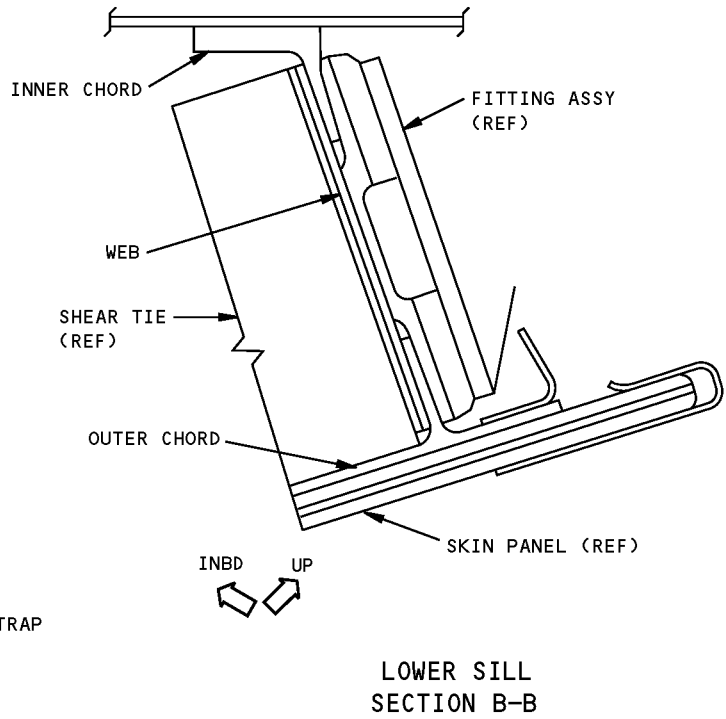
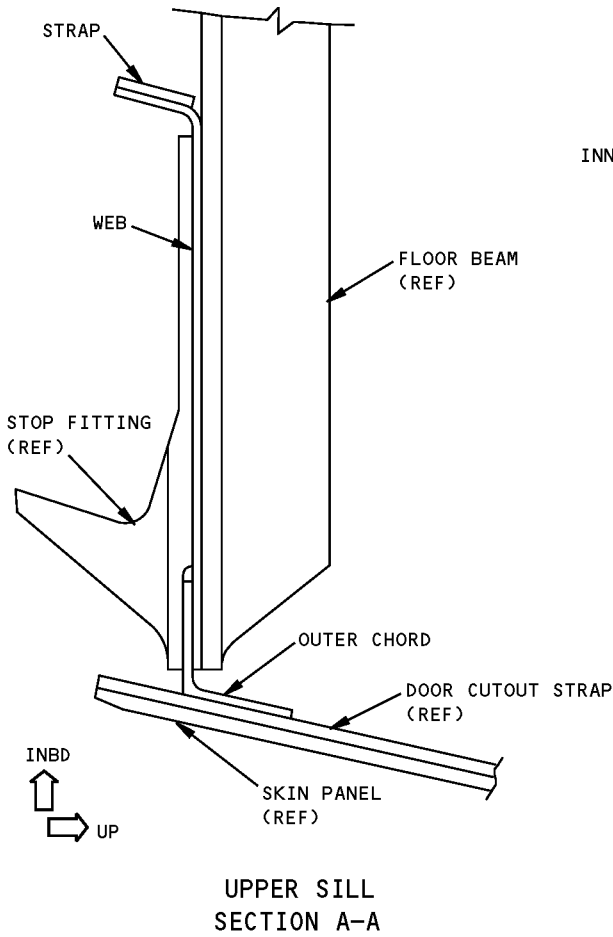
**Section 43 Door Surround Structure Allowable Damage
Figure 101 (Sheet 2 of 7)**

ALLOWABLE DAMAGE 1
Page 102
Jan 20/2005

53-30-15

D634N201

**757-200
STRUCTURAL REPAIR MANUAL**

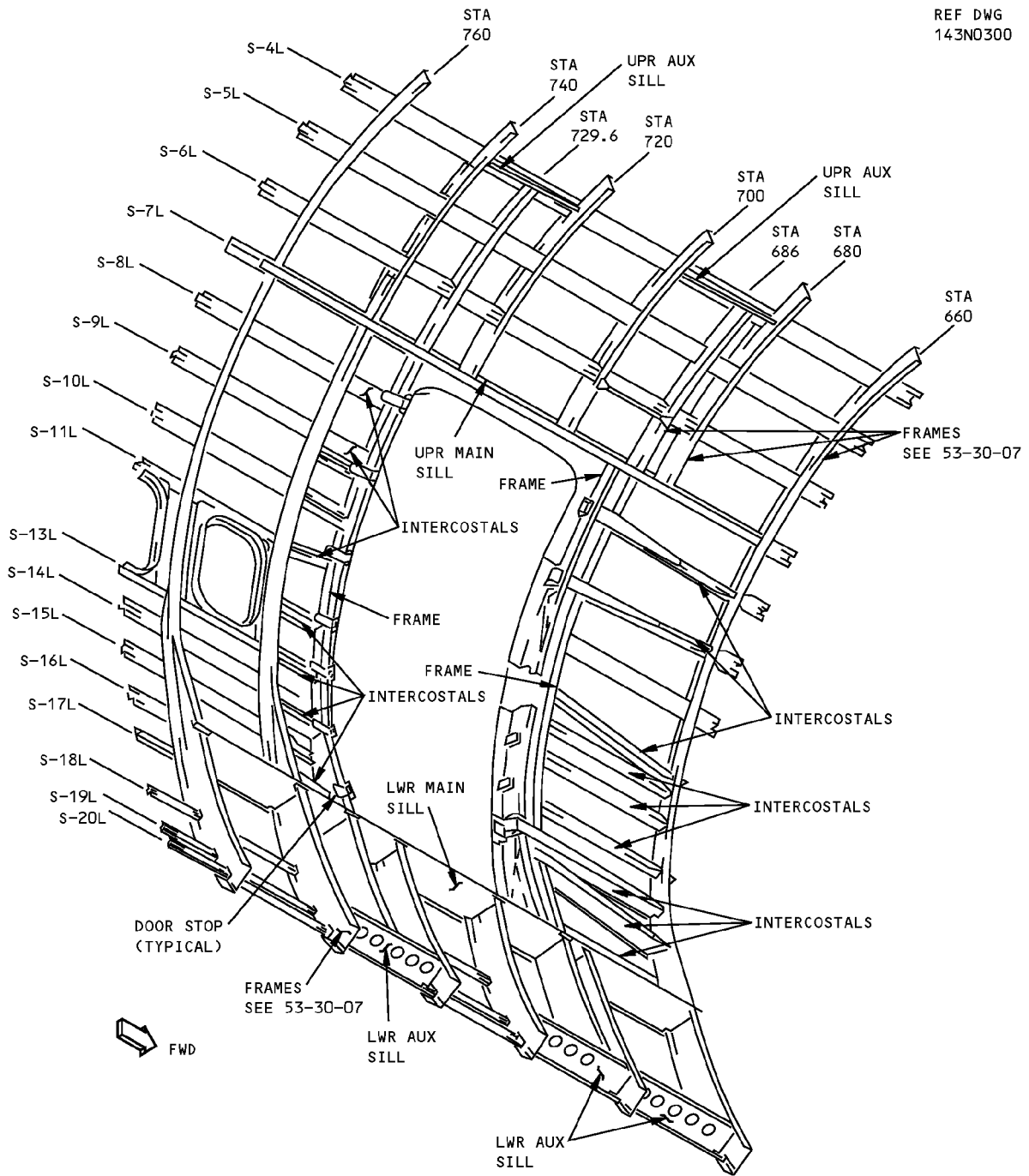


DESCRIPTION	CRACKS	NICKS, GOUGES AND CORROSION	DENTS	HOLES AND PUNCTURES
UPPER SILL				
WEB	C	B	SEE DETAIL V	D
OUTER CHORD	A	B	NOT ALLOWED	NOT ALLOWED
STRAP	C	B	NOT ALLOWED	NOT ALLOWED
LWR SILL				
WEB	C	B	SEE DETAIL V	D
OUTER CHORD	A	B	NOT ALLOWED	NOT ALLOWED
INNER CHORD	A	B	NOT ALLOWED	NOT ALLOWED
AUX SILL	C	B	SEE DETAIL V	D
INTERCOSTALS	C	B	SEE DETAIL V	D
FRAME ASSY	C	B	SEE DETAIL V	D

**Section 43 Door Surround Structure Allowable Damage
Figure 101 (Sheet 3 of 7)**

**757-200
STRUCTURAL REPAIR MANUAL**

REF DWG
143N0300



LEFT SIDE SHOWN
RIGHT SIDE OPPOSITE
PASSENGER DOOR SURROUND STRUCTURE
DETAIL II

MATERIAL: ALUMINUM

**Section 43 Door Surround Structure Allowable Damage
Figure 101 (Sheet 4 of 7)**



**757-200
STRUCTURAL REPAIR MANUAL**

DESCRIPTION	CRACKS	NICKS, GOUGES AND CORROSION	DENTS	HOLES AND PUNCTURES
UPPER MAIN SILL				
OUTER CHORD	A	B	NOT ALLOWED	NOT ALLOWED
WEB	C	B	SEE DETAIL V	D
STRAP	C	B	NOT ALLOWED	NOT ALLOWED
LWR MAIN SILL				
OUTER CHORD	A	B	NOT ALLOWED	NOT ALLOWED
WEB	C	B	SEE DETAIL V	D
INNER CHORD	A	B	NOT ALLOWED	NOT ALLOWED
UPR AUX SILL	C	B	SEE DETAIL V	D
LWR AUX SILL	C	B	SEE DETAIL V	D
INTERCOSTALS	C	B	SEE DETAIL V	D
FRAME ASSY	C	B	SEE DETAIL V	D

NOTES

- REFINISH REWORKED AREAS PER 51-20 OF THE MAINTENANCE MANUAL

A CRACKS NOT ALLOWED EXCEPT FOR EDGE CRACKS WHICH MUST BE REMOVED PER DETAILS III AND VIII

B REMOVE DAMAGE PER DETAILS III, IV AND VI

C CRACKS NOT ALLOWED EXCEPT FOR EDGE CRACKS WHICH MUST BE REMOVED PER DETAILS III AND VII

D CLEAN OUT DAMAGE UP TO 0.25 MAX DIA AND NOT CLOSER THAN 1.0 INCH TO FASTENER HOLE OR OTHER DAMAGE. FILL HOLE WITH A 2117-T3 OR T4 ALUMINUM RIVET INSTALLED WET WITH BMS 5-95 SEALANT. ALL OTHER HOLES TO BE REPAIRED

**Section 43 Door Surround Structure Allowable Damage
Figure 101 (Sheet 5 of 7)**

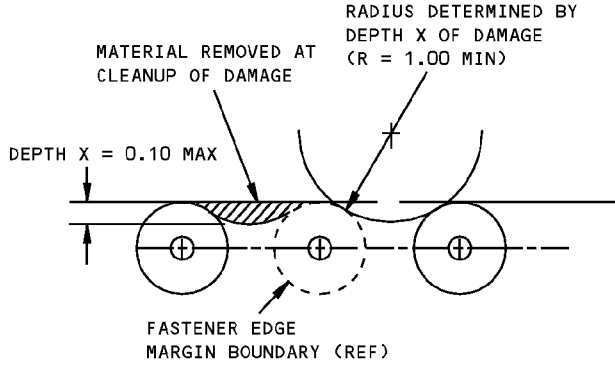
ALLOWABLE DAMAGE 1

53-30-15

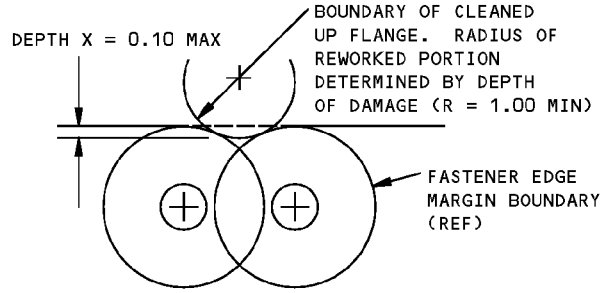
Page 105
Jan 20/2005

D634N201

**757-200
STRUCTURAL REPAIR MANUAL**

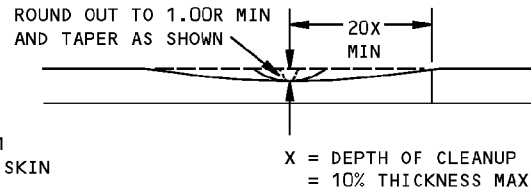
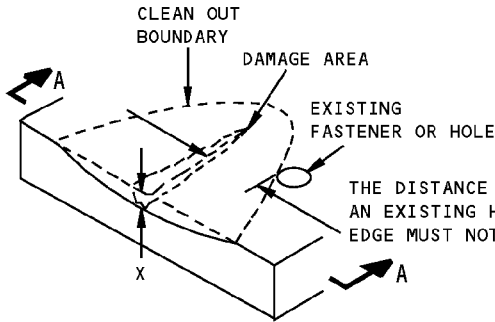


DAMAGE CLEANUP OF EDGES WHERE FASTENER EDGE MARGINS DO NOT OVERLAP



DAMAGE CLEANUP OF EDGES WHERE FASTENER EDGE MARGINS OVERLAP

DETAIL III

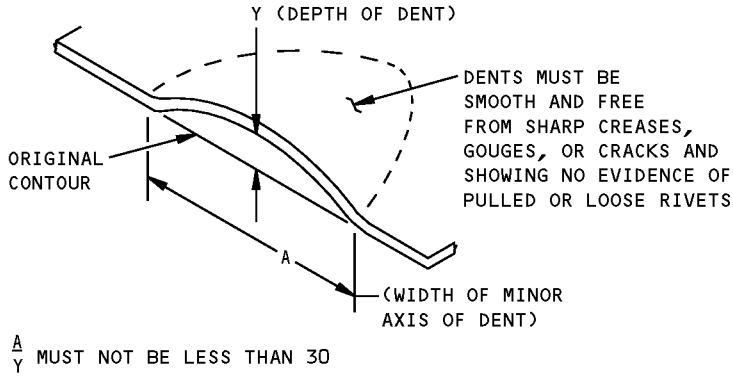


SECTION A-A

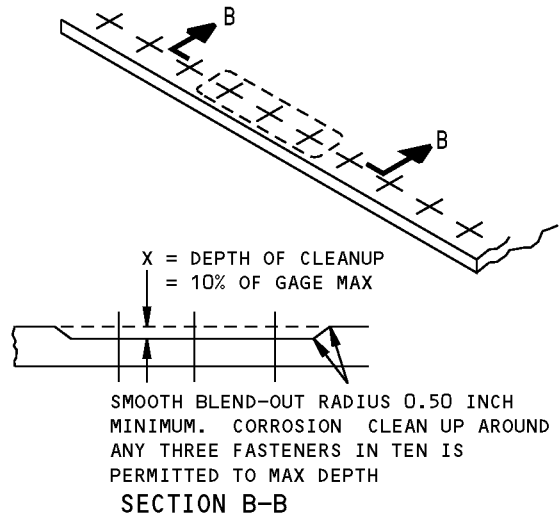
REMOVAL OF NICK, GOUGE AND SCRATCH DAMAGE ON A SURFACE
DETAIL IV

**Section 43 Door Surround Structure Allowable Damage
Figure 101 (Sheet 6 of 7)**

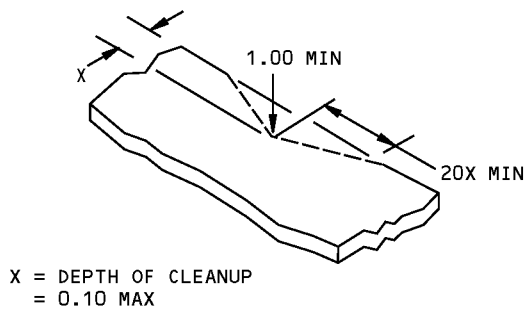
**757-200
STRUCTURAL REPAIR MANUAL**



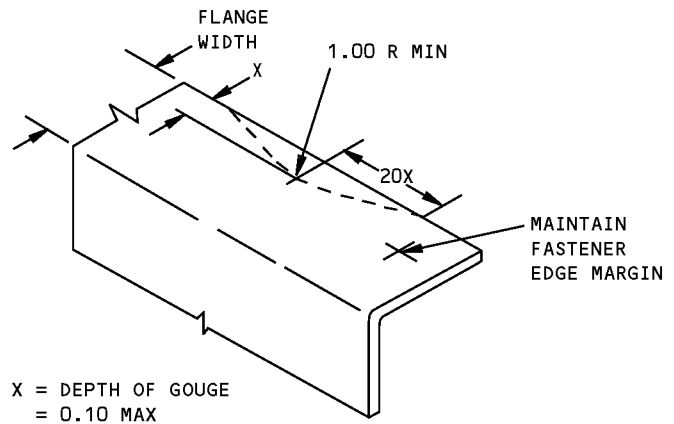
**ALLOWABLE DAMAGE FOR DENT
DETAIL V**



**CORROSION CLEANUP
DETAIL VI**



DETAIL VII

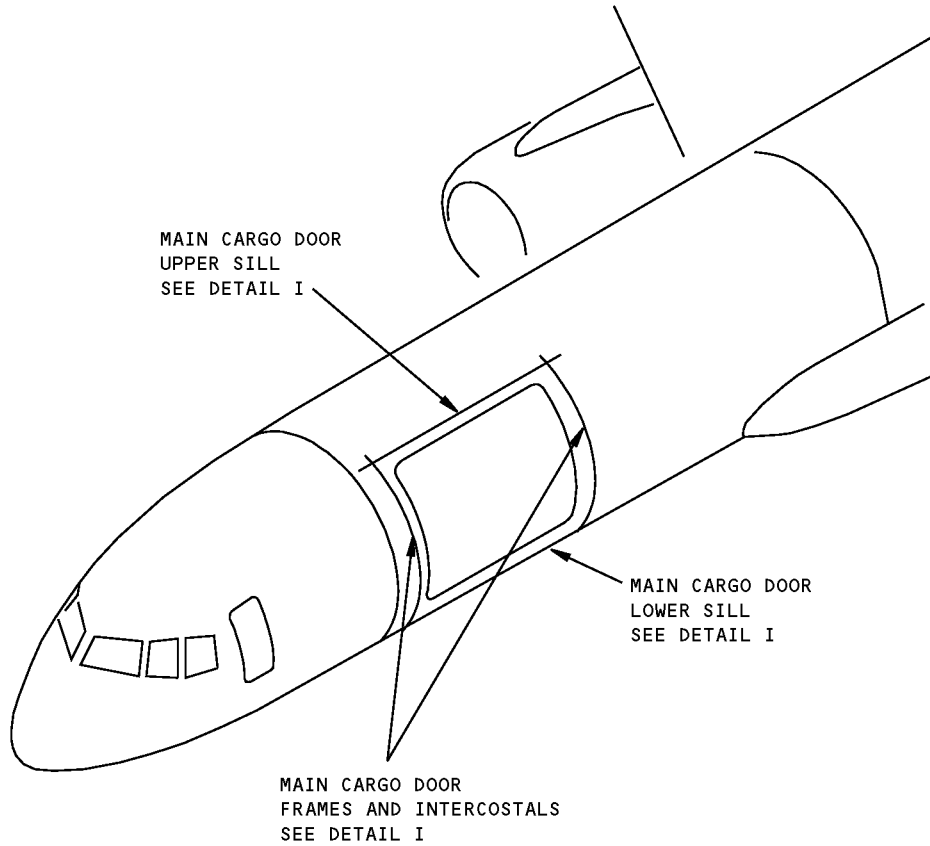


**REMOVAL OF NICK OR CRACK DAMAGE ON AN EDGE
DETAIL VIII**

**Section 43 Door Surround Structure Allowable Damage
Figure 101 (Sheet 7 of 7)**

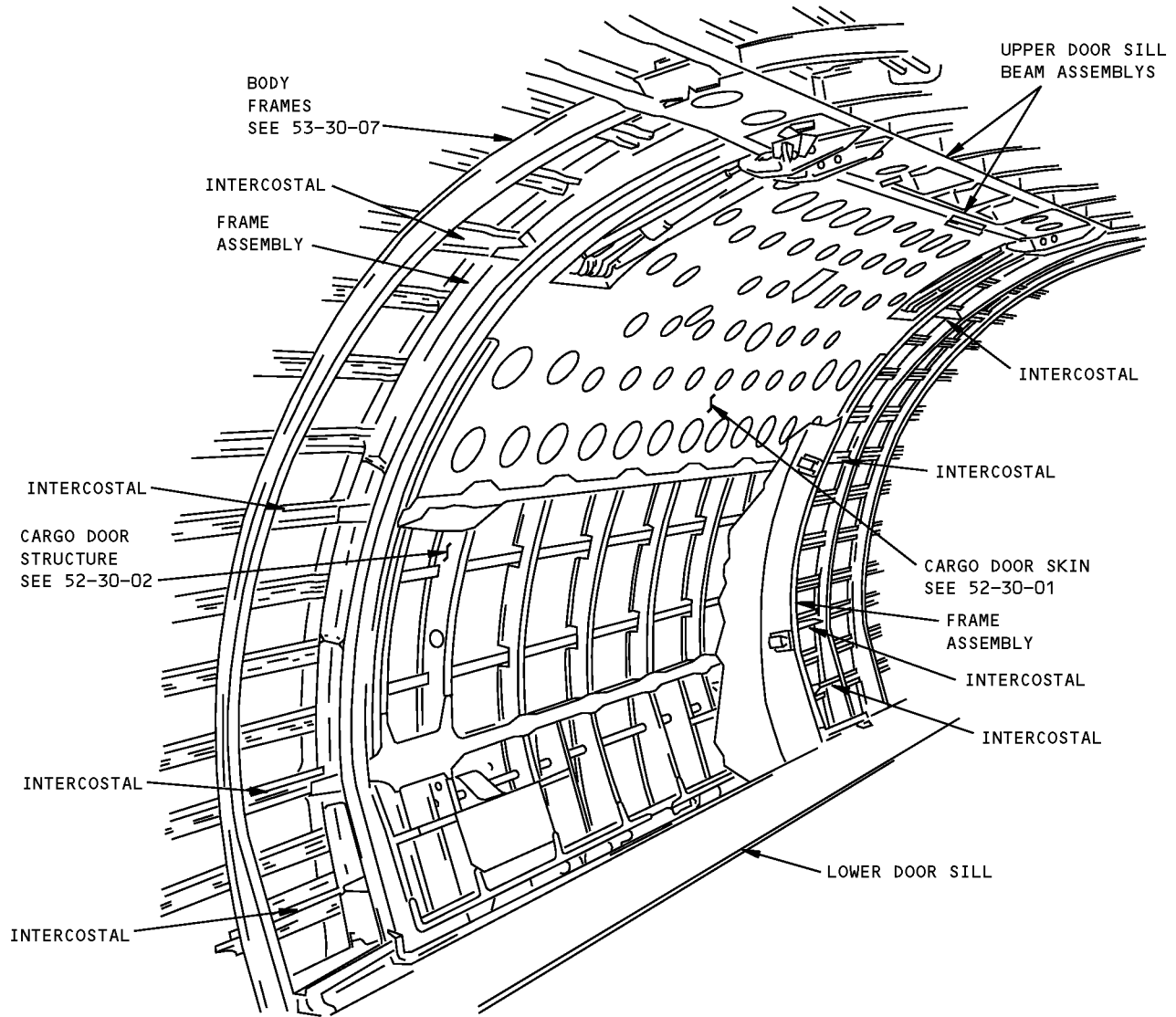
**757-200
STRUCTURAL REPAIR MANUAL**

ALLOWABLE DAMAGE 2 - MAIN DECK CARGO DOOR - DOOR SURROUND STRUCTURE - 757-SF



**Main Deck Cargo Door - Door Surround Structure Allowable Damage - 757-SF
Figure 101 (Sheet 1 of 5)**

**757-200
STRUCTURAL REPAIR MANUAL**



**MAIN CARGO DOOR
DETAIL I**



MATERIAL: ALUMINUM

**Main Deck Cargo Door - Door Surround Structure Allowable Damage - 757-SF
Figure 101 (Sheet 2 of 5)**

D634N201

ALLOWABLE DAMAGE 2
53-30-15
Page 102
Jan 20/2005



**757-200
STRUCTURAL REPAIR MANUAL**

DESCRIPTION	CRACKS	NICKS, GOUGES, SCRATCHES AND CORROSION	DENTS	HOLES AND PUNCTURES
UPPER DOOR SILL BEAM ASSYS				
OUTER CHORD	A	B	NOT PERMITTED	NOT PERMITTED
WEB	C	B	SEE DETAIL IV	D
INNER CHORD	A E	B E	NOT PERMITTED	NOT PERMITTED
LOWER DOOR SILL				
OUTER CHORD	A	B	NOT PERMITTED	NOT PERMITTED
WEB	C	B	SEE DETAIL IV	D
INNER CHORD	A	B	NOT PERMITTED	NOT PERMITTED
INTERCOSTALS	C	B	SEE DETAIL IV	D
FRAME ASSY	C	B	SEE DETAIL IV	D

ALLOWABLE DAMAGE LIMITS FOR DETAIL I

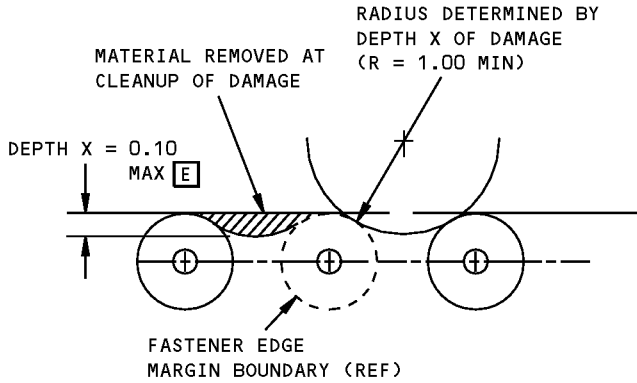
NOTES

- THIS ALLOWABLE DAMAGE IS A CATEGORY A REPAIR FOR 757-SF AIRPLANES. THE INSPECTIONS GIVEN IN THE MAINTENANCE PLANNING DATA (MPD) AND ASSOCIATED SUPPLEMENT ARE SUFFICIENT TO MAINTAIN THE DAMAGE TOLERANCE OF THE INITIAL STRUCTURE WITH THIS ALLOWABLE DAMAGE. REFER TO SRM 51-00-06 FOR REPAIR CATEGORIES AND DEFINITIONS.
- ALL DIMENSIONS ARE IN INCHES.
- REFINISH REWORKED AREAS AS GIVEN IN AMM 51-20.

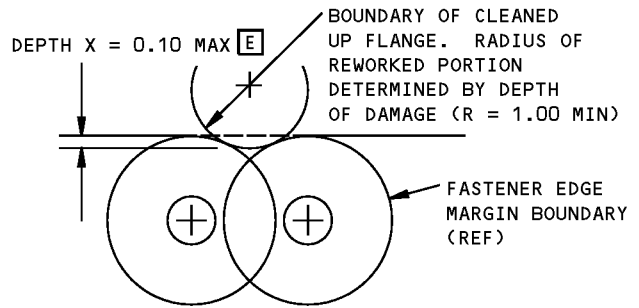
- A** CRACKS NOT PERMITTED EXCEPT FOR EDGE CRACKS WHICH MUST BE REMOVED. SEE DETAILS II AND VII.
- B** REMOVE DAMAGE. SEE DETAILS II, III AND V.
- C** CRACKS NOT PERMITTED EXCEPT FOR EDGE CRACKS WHICH MUST BE REMOVED. SEE DETAILS II AND VI.
- D** CLEAN OUT DAMAGE UP TO 0.25 MAXIMUM DIAMETER AND NOT CLOSER THAN 1.0 INCH TO FASTENER HOLE OR OTHER DAMAGE. FILL HOLE WITH A 2771-T3 OR T4 ALUMINUM RIVET INSTALLED WET WITH BMS 5-95 SEALANT. ALL OTHER HOLES TO BE REPAIRED.
- E** MAXIMUM EDGE TRIM IS 0.05 INCH FOR STRINGER 3L DOOR SILL INNER CHORD BETWEEN STA. 590 AND STA. 640.

**Main Deck Cargo Door - Door Surround Structure Allowable Damage - 757-SF
Figure 101 (Sheet 3 of 5)**

STRUCTURAL REPAIR MANUAL

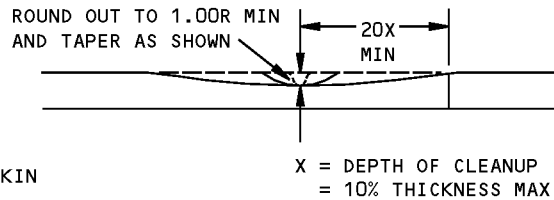
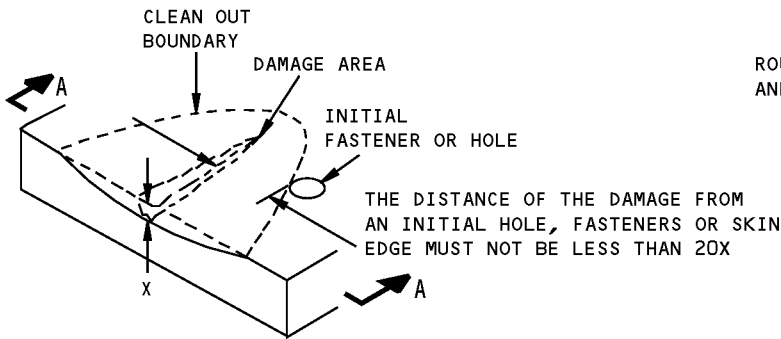


DAMAGE CLEANUP OF EDGES WHERE FASTENER EDGE MARGINS DO NOT OVERLAP



DAMAGE CLEANUP OF EDGES WHERE FASTENER EDGE MARGINS OVERLAP

DETAIL II

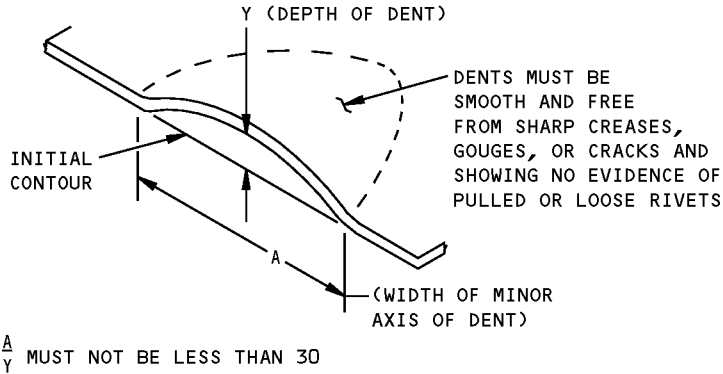


SECTION A-A

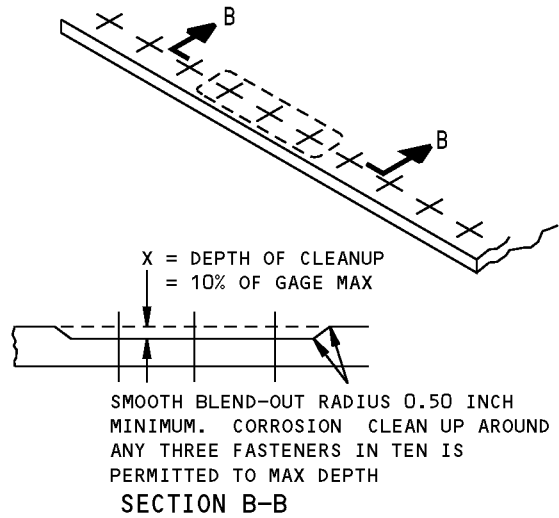
REMOVAL OF NICK, GOUGE AND SCRATCH DAMAGE ON A SURFACE
DETAIL III

Main Deck Cargo Door - Door Surround Structure Allowable Damage - 757-SF
Figure 101 (Sheet 4 of 5)

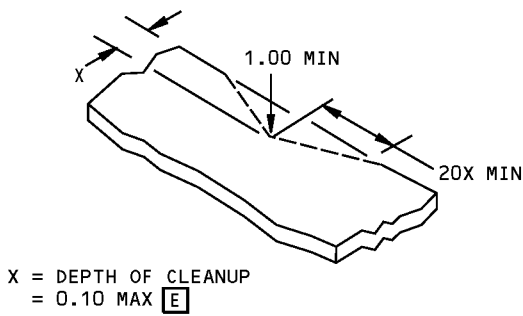
**757-200
STRUCTURAL REPAIR MANUAL**



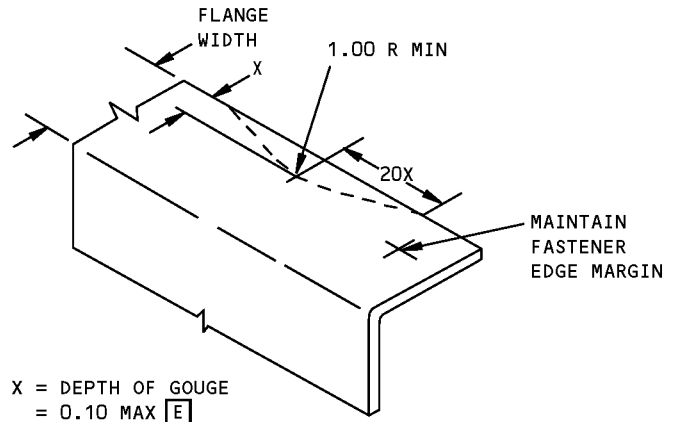
**ALLOWABLE DAMAGE FOR DENT
DETAIL IV**



**CORROSION CLEANUP
DETAIL V**



DETAIL VI

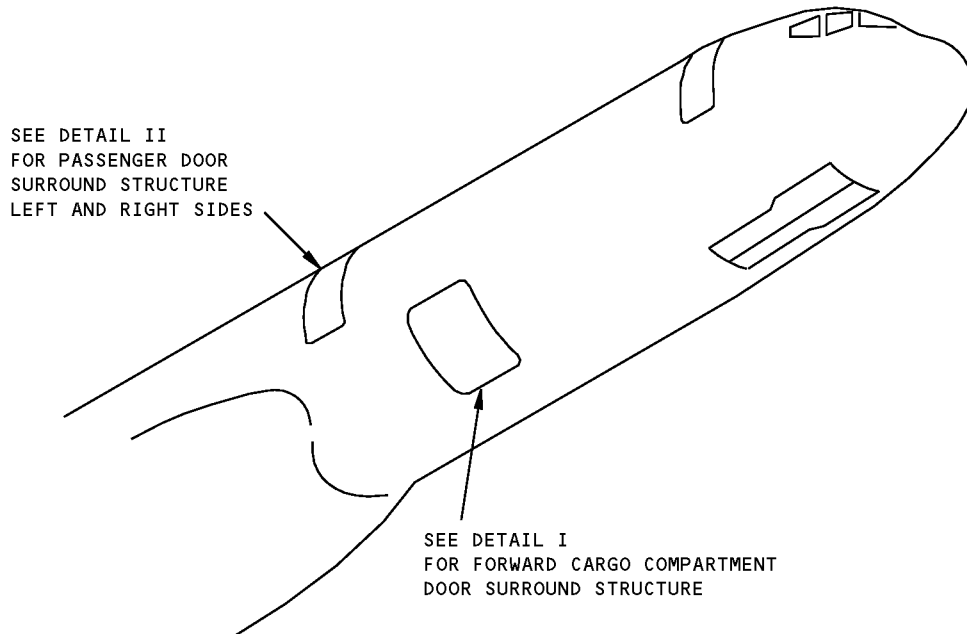


**REMOVAL OF NICK OR CRACK DAMAGE ON AN EDGE
DETAIL VII**

**Main Deck Cargo Door - Door Surround Structure Allowable Damage - 757-SF
Figure 101 (Sheet 5 of 5)**

757-200
STRUCTURAL REPAIR MANUAL

REPAIR GENERAL - SECTION 43 - DOOR SURROUND STRUCTURE



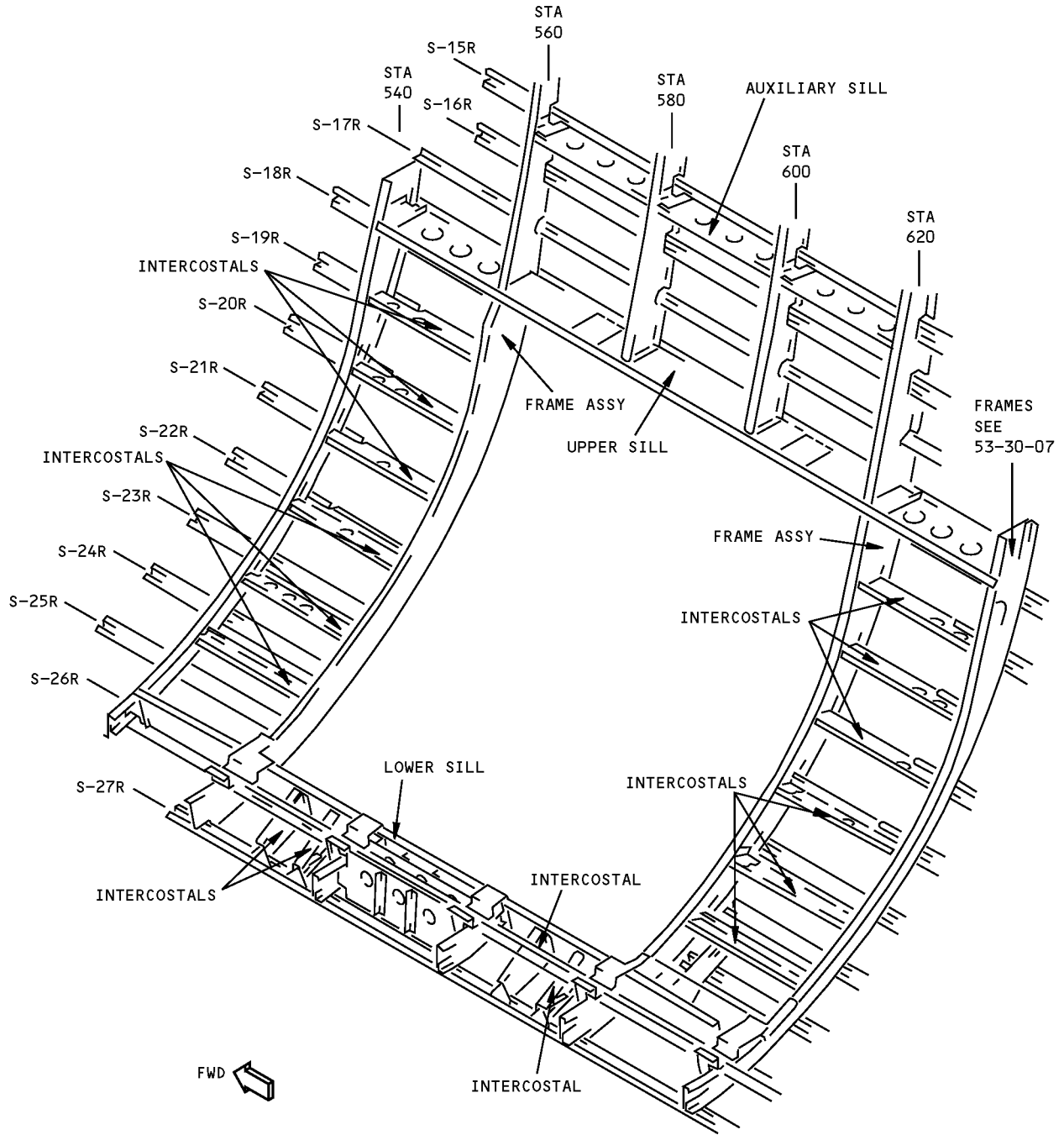
NOTES

- DAMAGED COMPONENTS IN DOOR SURROUND STRUCTURE MAY BE REPLACED OR REPAIRED. IF REPAIRS ARE TO BE MADE, SEE 51-70 FOR TYPICAL WEB, AND EXTRUDED SECTION REPAIRS

Section 43 Door Surround Structure Repair
Figure 201 (Sheet 1 of 3)

**757-200
STRUCTURAL REPAIR MANUAL**

REF DWG
143N0212

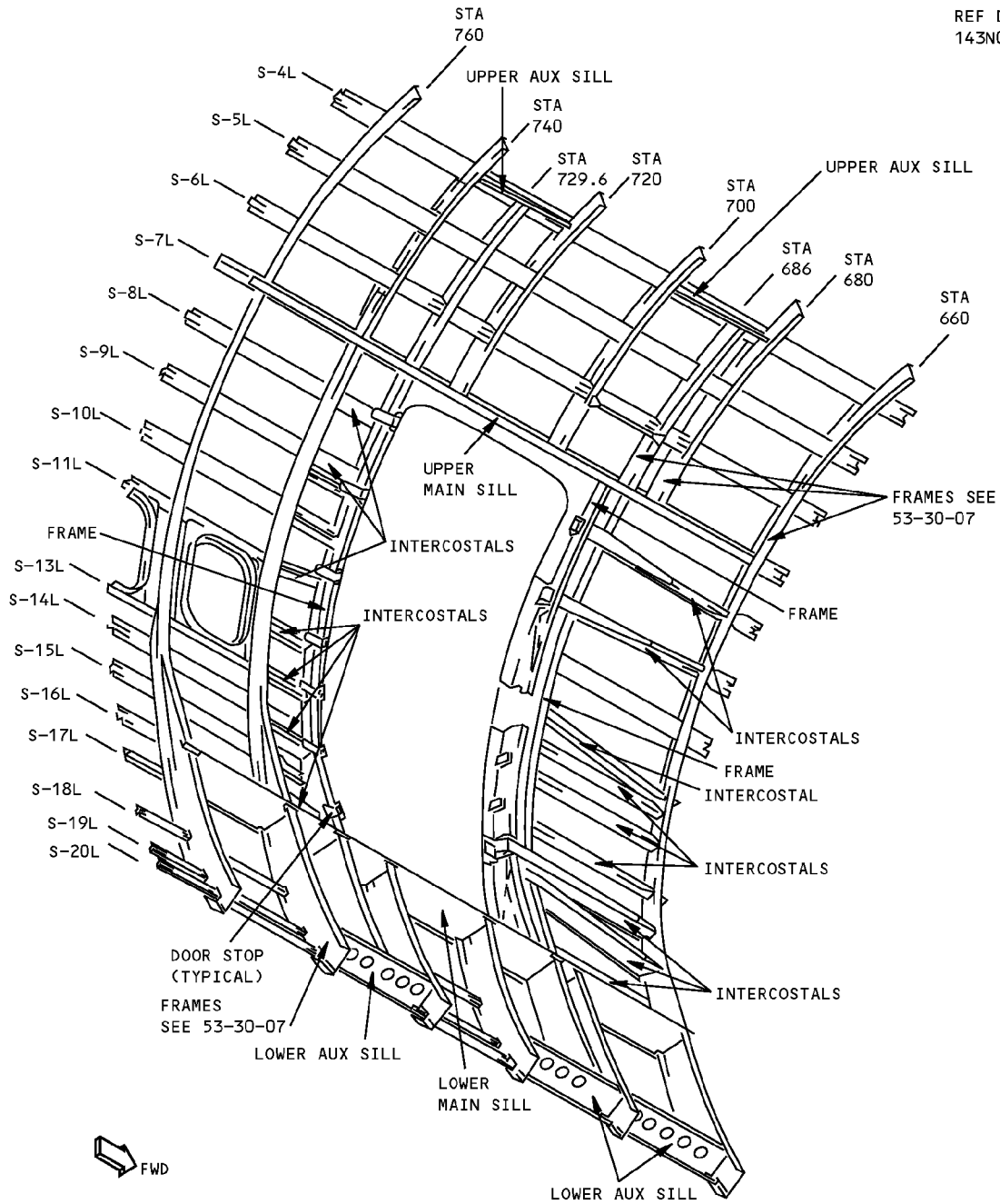


**FORWARD CARGO COMPARTMENT DOOR SURROUND STRUCTURE
DETAIL I**

**Section 43 Door Surround Structure Repair
Figure 201 (Sheet 2 of 3)**

**757-200
STRUCTURAL REPAIR MANUAL**

REF DWG
143N0300



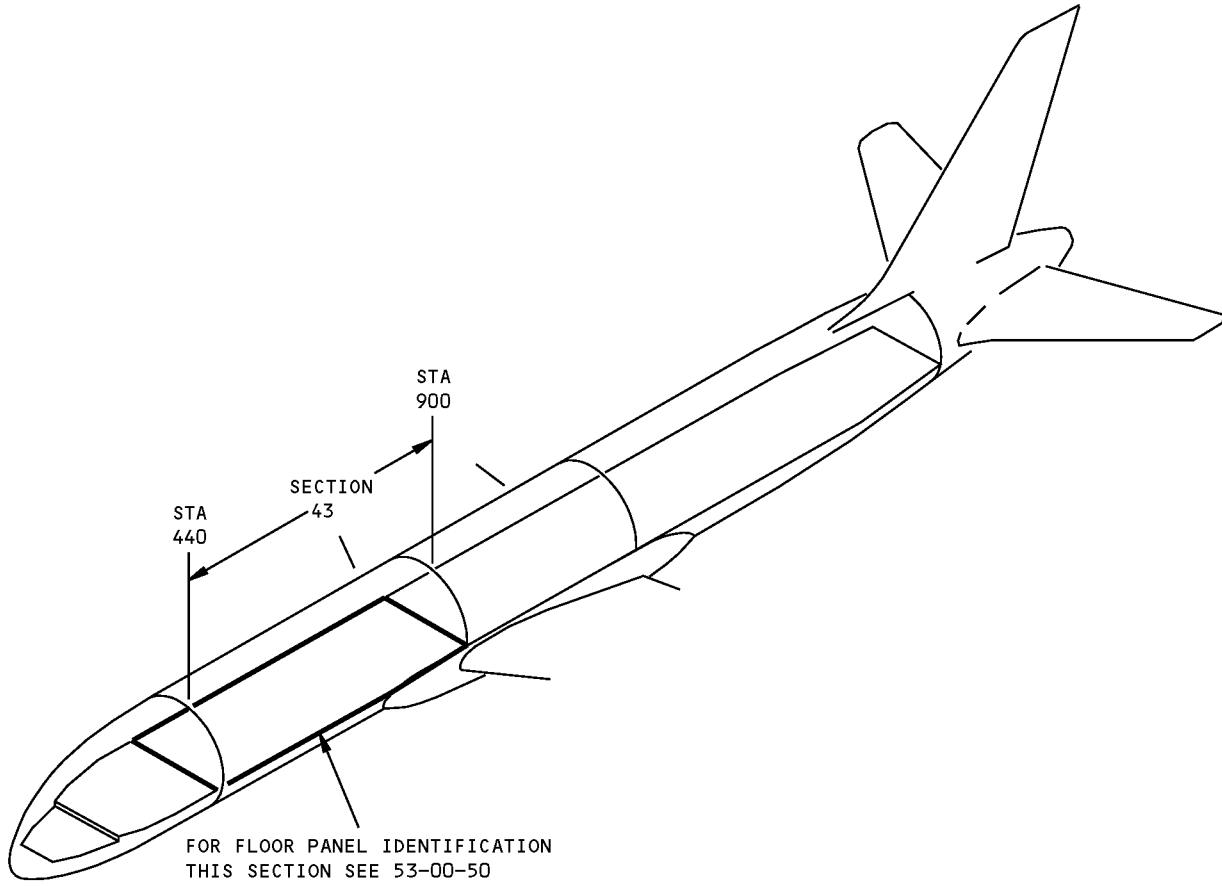
LEFT SIDE SHOWN
RIGHT SIDE OPPOSITE
PASSENGER DOOR SURROUND STRUCTURE
DETAIL II

**Section 43 Door Surround Structure Repair
Figure 201 (Sheet 3 of 3)**



**757-200
STRUCTURAL REPAIR MANUAL**

IDENTIFICATION GENERAL - SECTION 43 - MAIN DECK FLOOR PANELS



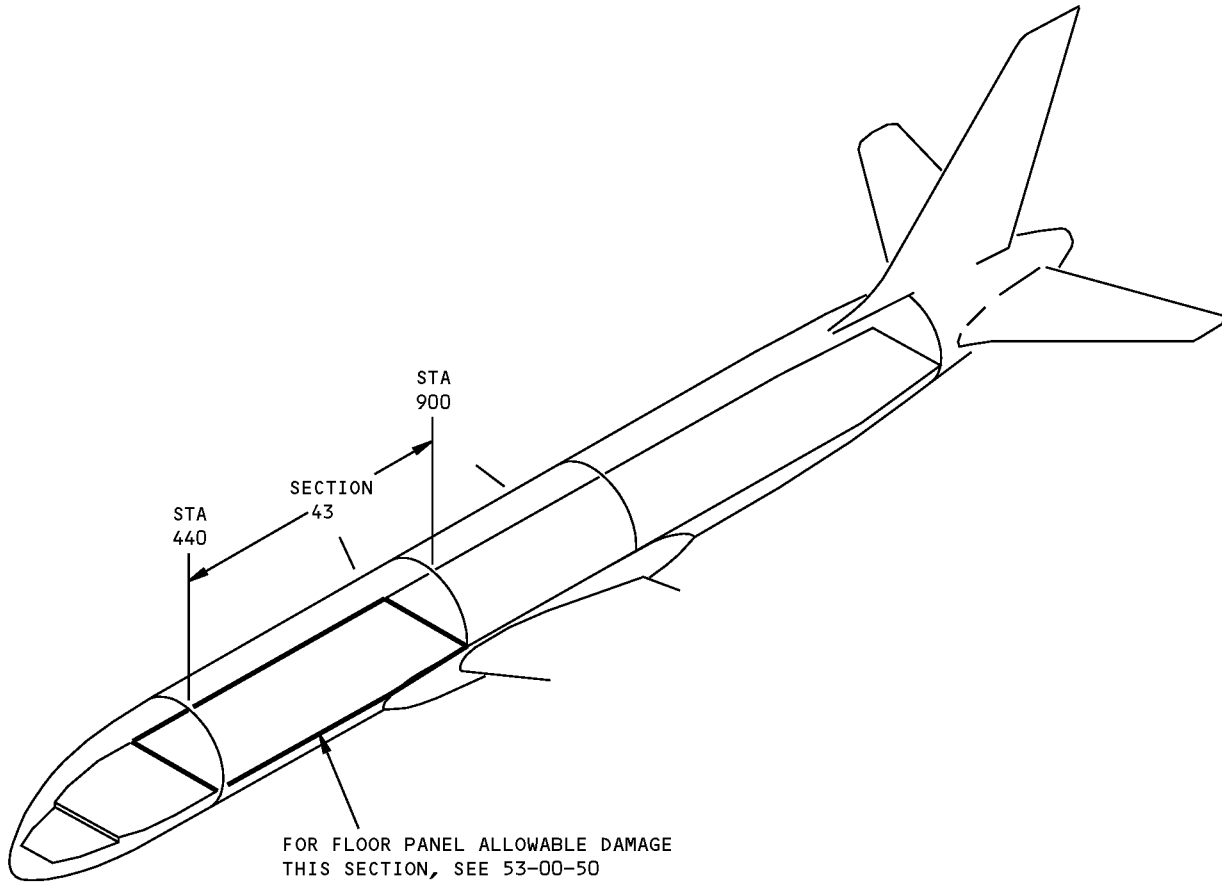
**Section 43 Main Deck Floor Panel Identification
Figure 1**

D634N201

IDENTIFICATION GENERAL
Page 1
53-30-50
Jan 20/2005

**757-200
STRUCTURAL REPAIR MANUAL**

ALLOWABLE DAMAGE GENERAL - SECTION 43 - MAIN DECK FLOOR PANELS

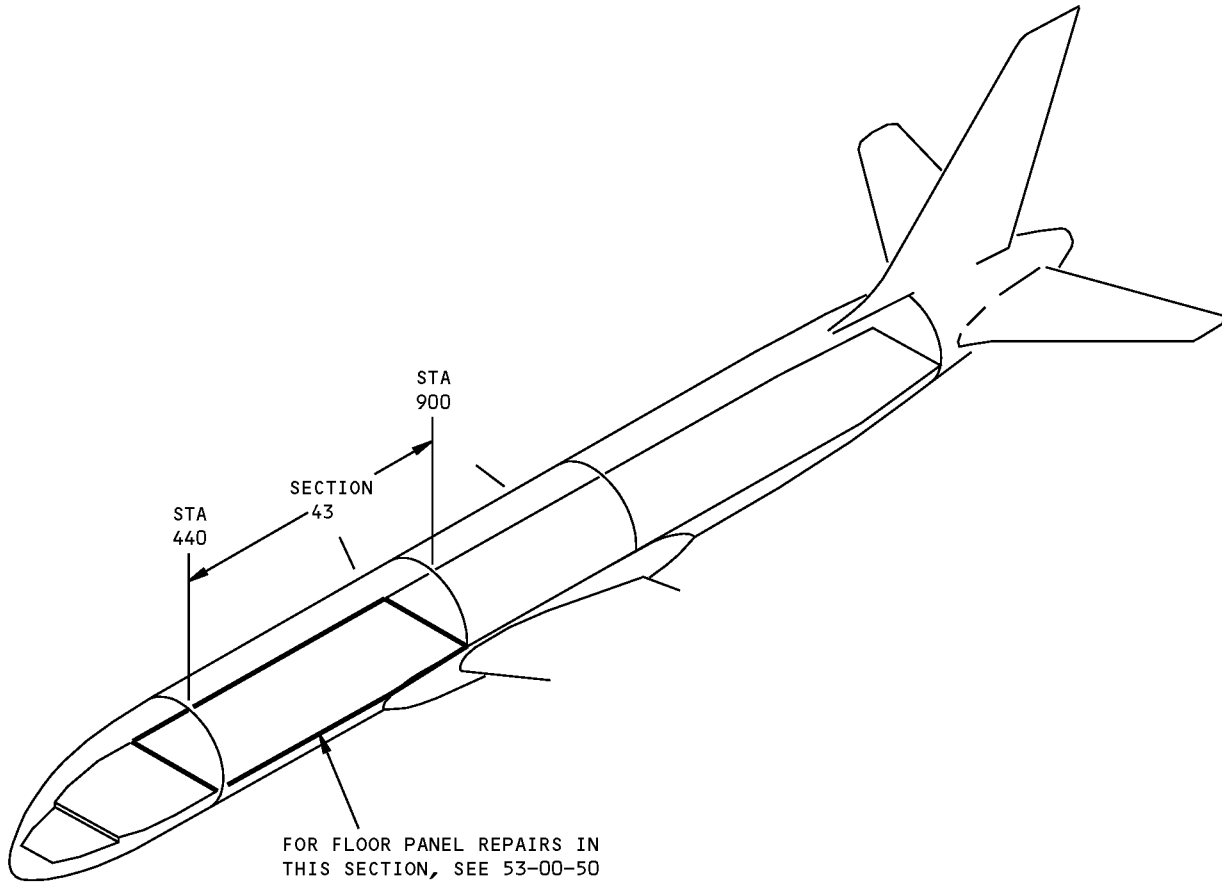


**Section 43 Main Deck Floor Panel Allowable Damage
Figure 101**

D634N201

757-200
STRUCTURAL REPAIR MANUAL

REPAIR GENERAL - SECTION 43 - MAIN DECK FLOOR PANELS



Section 43 Main Deck Floor Panel Repairs
Figure 201

D634N201

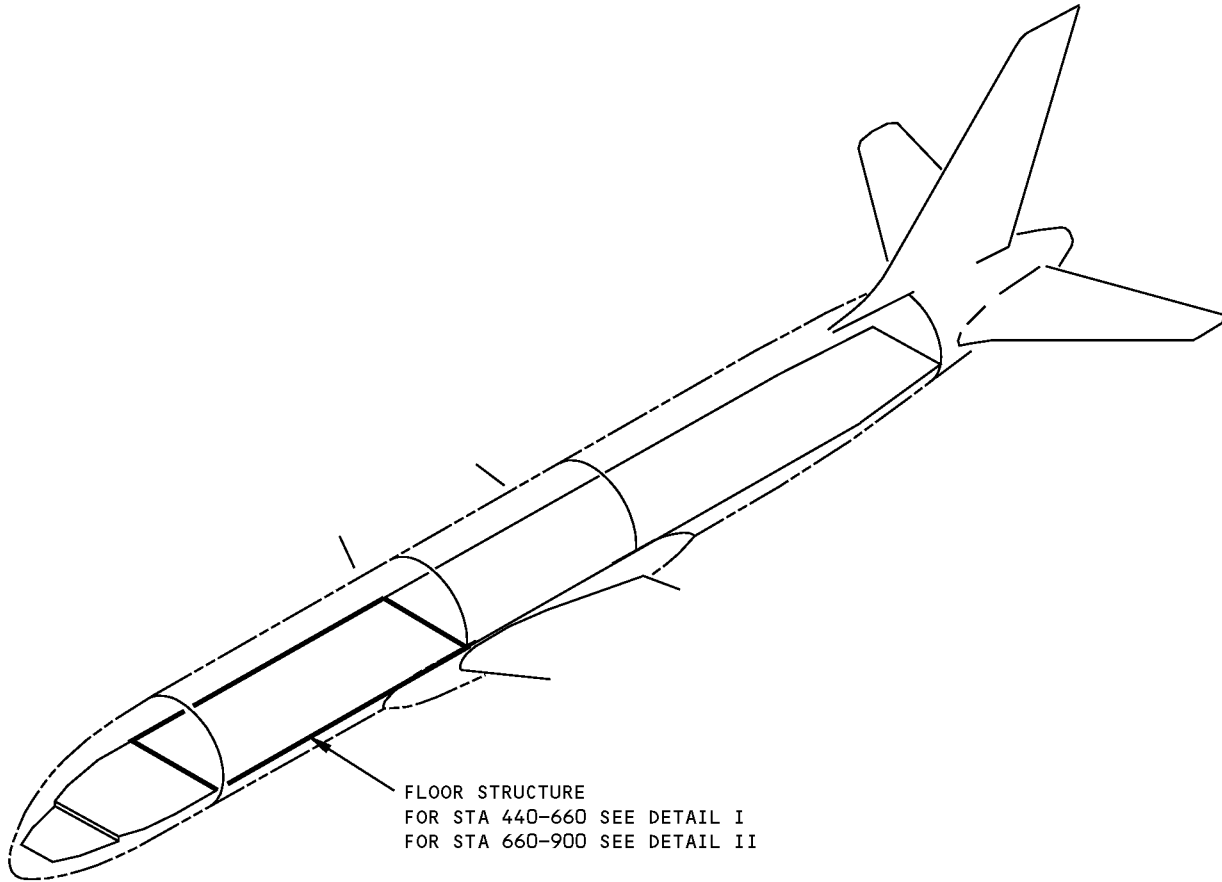
53-30-50

REPAIR GENERAL
Page 201
Jan 20/2005



757-200
STRUCTURAL REPAIR MANUAL

IDENTIFICATION 1 - SECTION 43 - MAIN DECK FLOOR STRUCTURE



NOTES

- TOP OF FLOOR BEAM WL 208.10
- A** FOR CUM LINE NUMBERS:
2 THRU 5
- B** FOR 757-SF AIRPLANES ONLY
- C** FOR 757 PASSENGER AIRPLANES

Section 43 Main Deck Floor Structure Identification
Figure 1 (Sheet 1 of 9)

D634N201

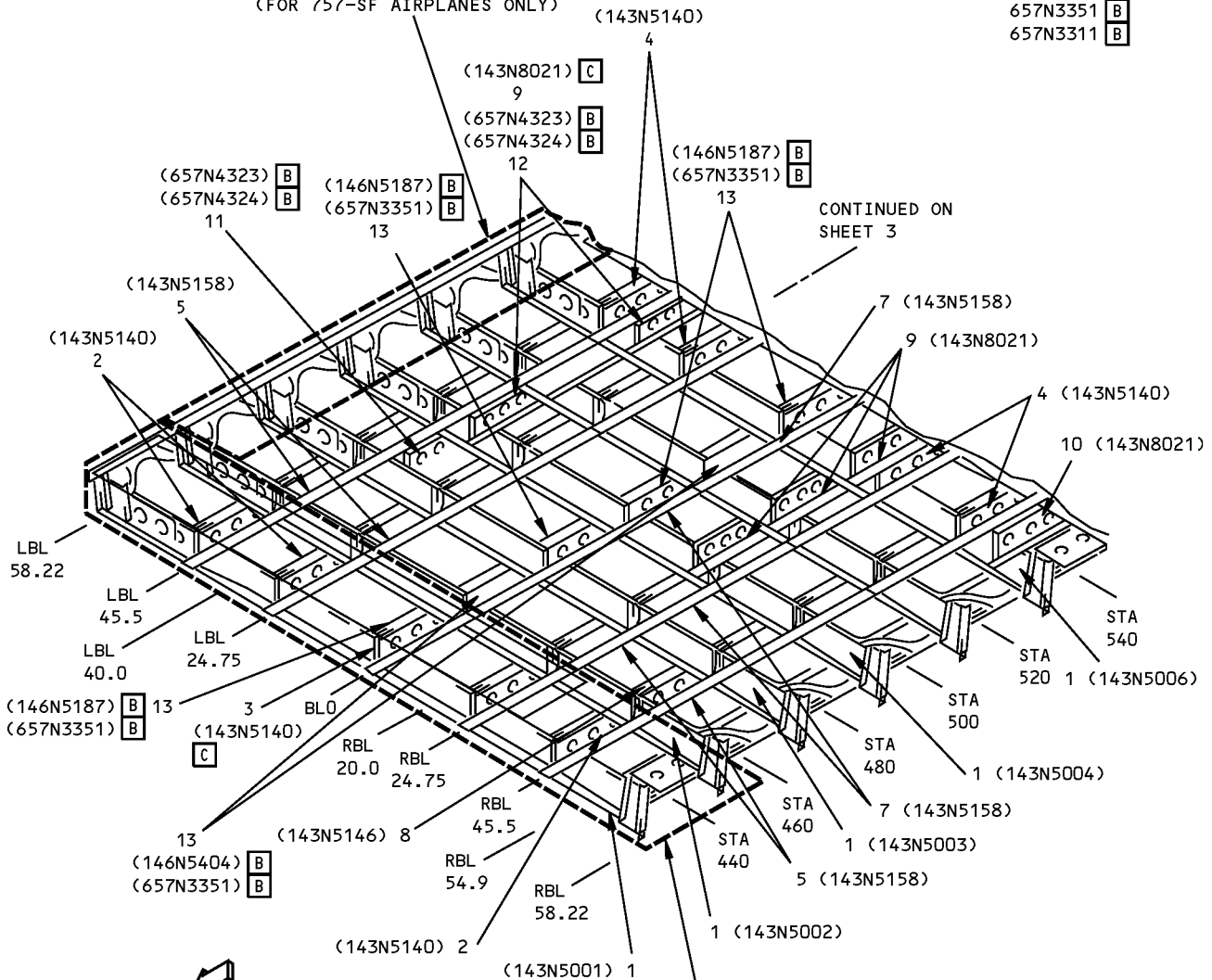
53-30-51

IDENTIFICATION 1
Page 1
Jan 20/2005

**757-200
STRUCTURAL REPAIR MANUAL**

REFERENCE DRAWING
140N1550
143N5000
657N4330 **B**
657N4331 **B**
657N3351 **B**
657N3311 **B**

SEE DETAIL IV FOR THE SHEAR WEB IDENTIFICATION
SEE DETAIL V FOR TYPICAL BEAM SPLICE AT
STA. 480-560, LBL 58.22.
(FOR 757-SF AIRPLANES ONLY)



CONTINUED ON SHEET 3

SEE DETAIL III FOR THE SHEAR WEB IDENTIFICATION
(FOR 757-SF AIRPLANES ONLY)

DETAIL I



**Section 43 Main Deck Floor Structure Identification
Figure 1 (Sheet 2 of 9)**

IDENTIFICATION 1
Page 2
Jan 20/2005

53-30-51

D634N201

757-200 STRUCTURAL REPAIR MANUAL

REFERENCE DRAWING
 140N1550
 143N5000
 657N4330

B

 675N4331

B

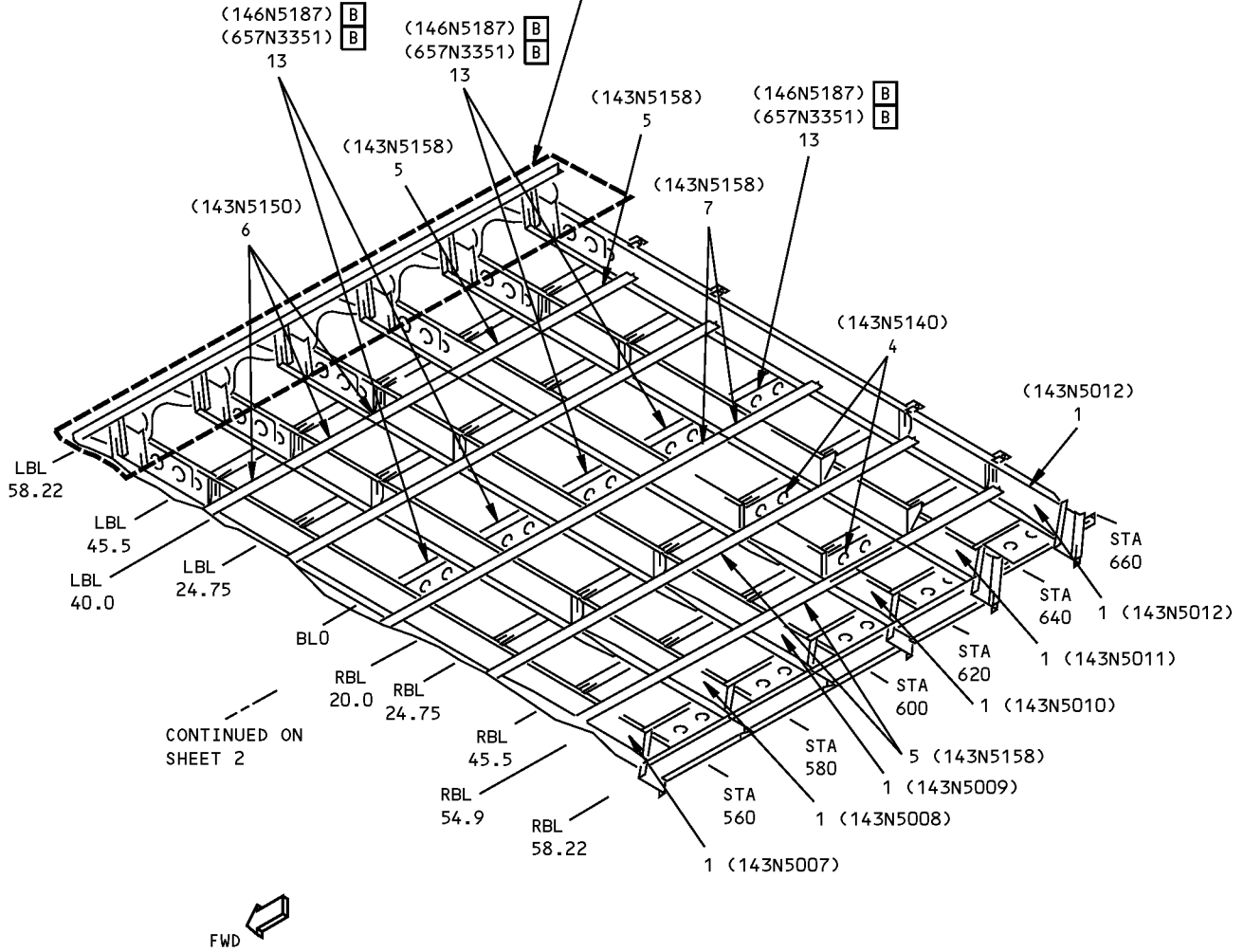
 657N3351

B

 657N3311

B

SEE DETAIL IV FOR THE SHEAR WEB IDENTIFICATION
 SEE DETAIL V FOR TYPICAL BEAM SPLICE AT
 STA. 480-560, LBL 58.22.
 (FOR 757-SF AIRPLANES ONLY)



DETAIL I

LIST OF
MATL

Section 43 Main Deck Floor Structure Identification
 Figure 1 (Sheet 3 of 9)

IDENTIFICATION 1
 Page 3
 Jan 20/2005

53-30-51

D634N201



**757-200
STRUCTURAL REPAIR MANUAL**

ITEM	DESCRIPTION	GAGE	MATERIAL	EFFECTIVITY
1	FLOOR BEAM		BAC1518-338 7075-T6511	
2	INTERCOSTAL ANGLE SHEAR WEB CHANNEL	0.032 0.025 0.025	7075-T6 7075-T6 7075-T6	
3	INTERCOSTAL ANGLE SHEAR WEB	0.032 0.032	7075-T6 7075-T6	C
4	INTERCOSTAL ANGLE SHEAR WEB	0.032 0.025	7075-T6 7075-T6	
5	STRAP		BAC1493-577 CLAD 7075-T6	
6	STRAP	0.050	CLAD 7075-T6	
7	STRAP		BAC1513-295 7075-T6	
8	INTERCOSTAL ANGLE WEB CHANNEL	0.063 0.032	CLAD 7075-T6 CLAD 7075-T6 BAC1493-479 CLAD 7075-T6	
9	INTERCOSTAL	0.063	CLAD 7075-T6	
10	INTERCOSTAL	0.040	CLAD 7075-T6	A
11	INTERCOSTAL WEB CHANNEL	0.032 0.032	7075-T62 CLAD 7075-T62 CLAD	B
12	INTERCOSTAL WEB CHANNEL	0.050 0.063	7075-T62 CLAD 7075-T62 CLAD	B
13	INTERCOSTAL WEB CHANNEL	0.045	7075-T6 CLAD BAC1506-1706 7075-T6511	B

LIST OF MATERIALS FOR DETAIL I

**Section 43 Main Deck Floor Structure Identification
Figure 1 (Sheet 4 of 9)**

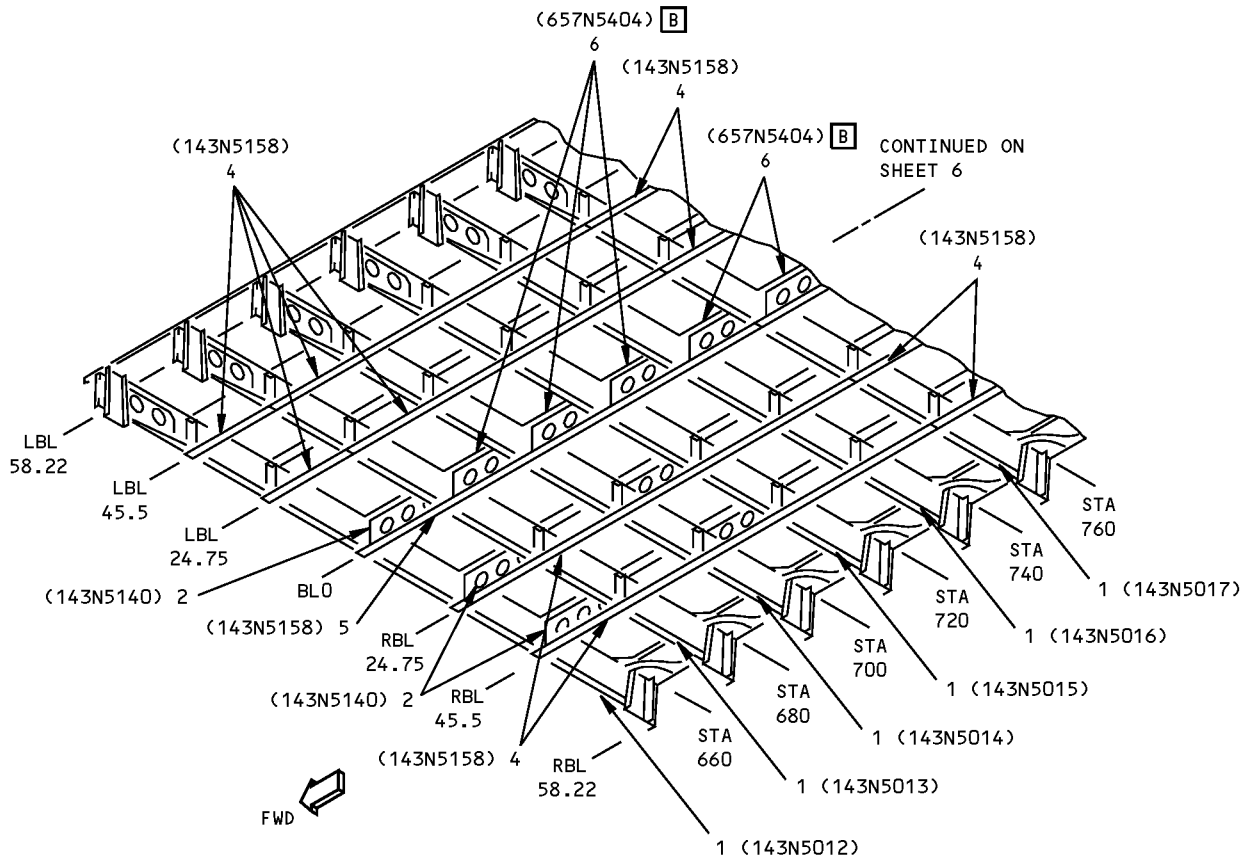
IDENTIFICATION 1
Page 4
Jan 20/2005

53-30-51

D634N201

**757-200
STRUCTURAL REPAIR MANUAL**

REFERENCE DRAWING
140N1550
143N5000
657N3311 **B**
657N3351 **B**



DETAIL II



**Section 43 Main Deck Floor Structure Identification
Figure 1 (Sheet 5 of 9)**

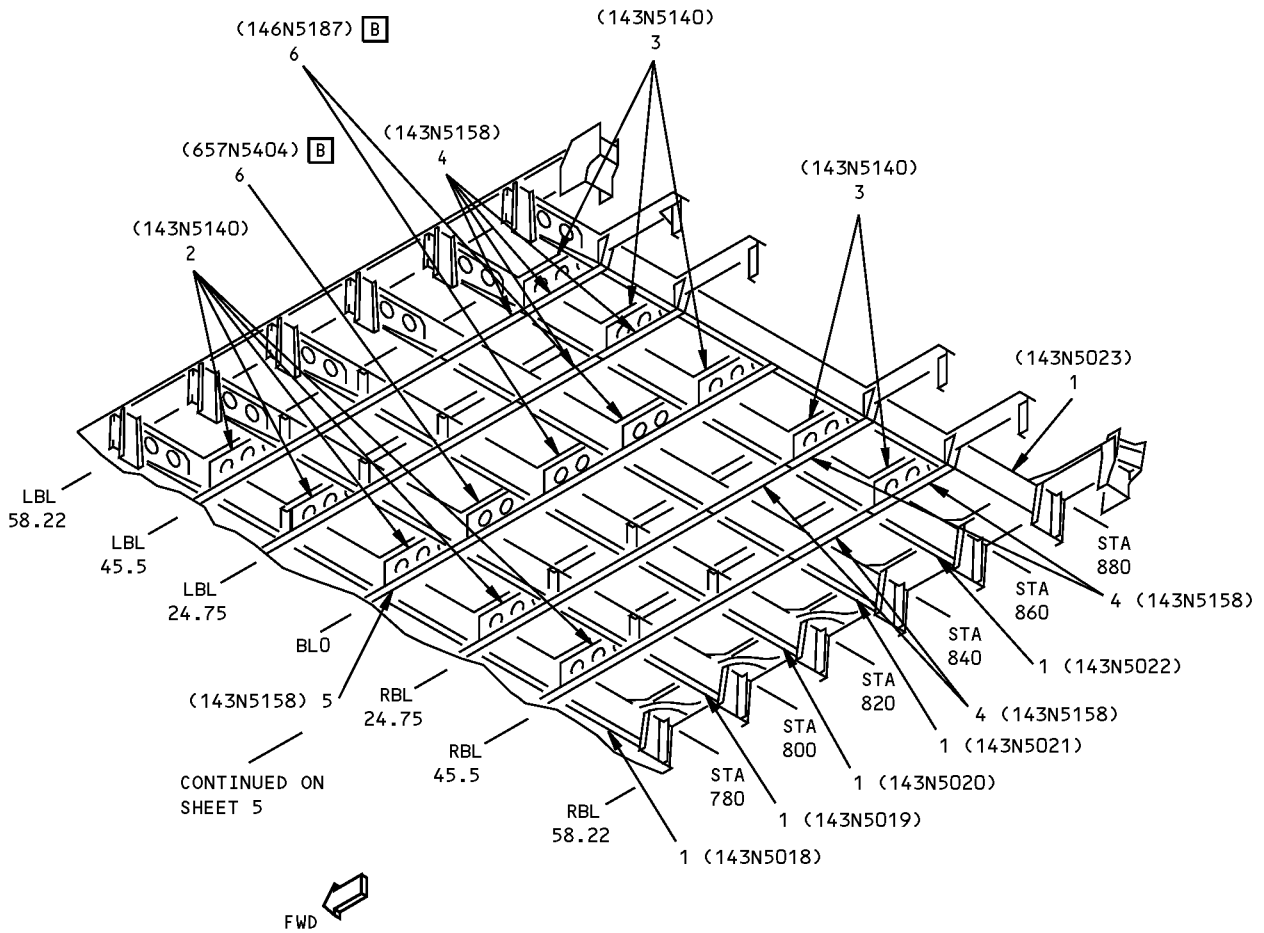
IDENTIFICATION 1
Page 5
Jan 20/2005

53-30-51

D634N201

**757-200
STRUCTURAL REPAIR MANUAL**

REFERENCE DRAWING
140N1550
143N5000
657N3311 **B**
657N3351 **B**



DETAIL II



**Section 43 Main Deck Floor Structure Identification
Figure 1 (Sheet 6 of 9)**

IDENTIFICATION 1
Page 6
Jan 20/2005

53-30-51

D634N201



757-200
STRUCTURAL REPAIR MANUAL

ITEM	DESCRIPTION	GAGE	MATERIAL	EFFECTIVITY
1	FLOOR BEAM		BAC1518-338 7075-T6511	
2	INTERCOSTAL ANGLE	0.032	7075-T6	
	SHEAR WEB	0.025	7075-T6	
3	INTERCOSTAL ANGLE	0.032	7075-T6	
	SHEAR WEB	0.025	7075-T6	
4	STRAP		BAC1493-577 7075-T6	
5	STRAP		BAC1513-295 7075-T6	
6	INTERCOSTAL SHEAR WEB CHORD	0.045	7075-T6 CLAD BAC1506-1706 7075-T6511	B

LIST OF MATERIALS FOR DETAIL II

Section 43 Main Deck Floor Structure Identification
Figure 1 (Sheet 7 of 9)

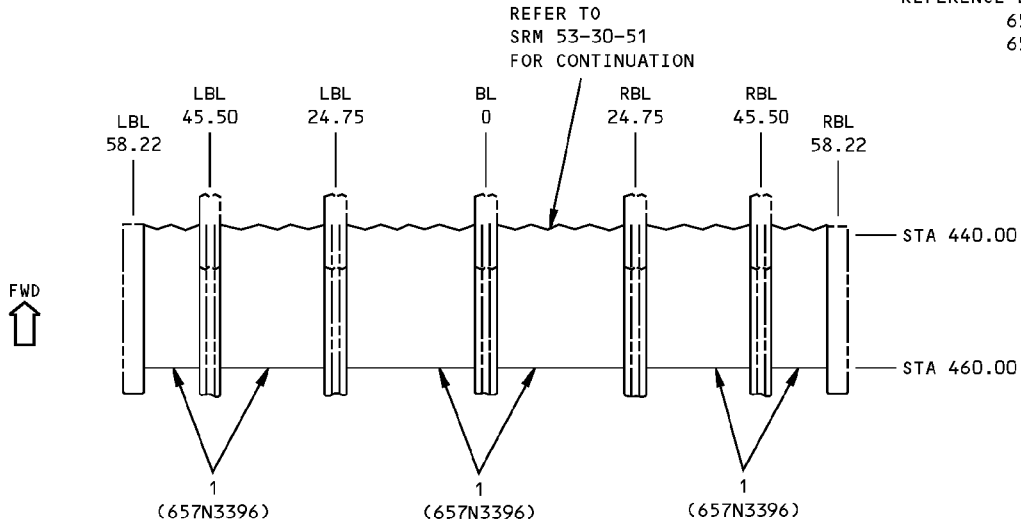
D634N201

53-30-51

IDENTIFICATION 1
Page 7
Jan 20/2005

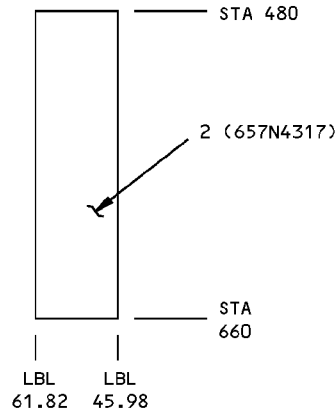
**757-200
STRUCTURAL REPAIR MANUAL**

REFERENCE DRAWING
657N3395
657N3399



SHEAR WEB IDENTIFICATION

DETAIL III B



SHEAR WEB IDENTIFICATION

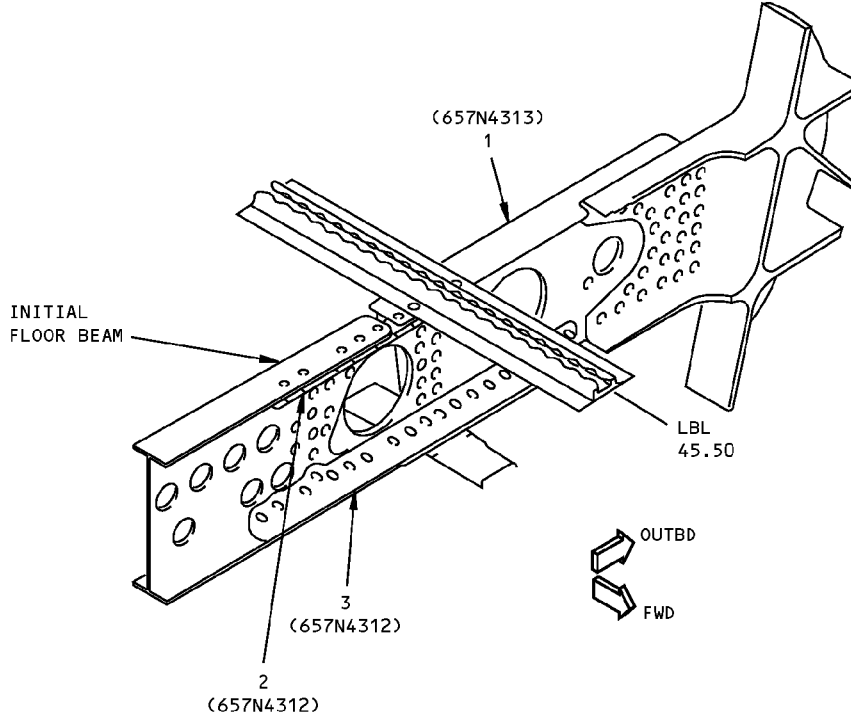
DETAIL IV B

ITEM	DESCRIPTION	GAGE	MATERIAL	EFFECTIVITY
1	SHEAR WEB	0.100	CLAD 7075-T6	B
2	SHEAR WEB	0.071	CLAD 7075-T6	B

LIST OF MATERIALS FOR DETAIL III AND IV

**Section 43 Main Deck Floor Structure Identification
Figure 1 (Sheet 8 of 9)**

**757-200
STRUCTURAL REPAIR MANUAL**



TYPICAL BEAM SPLICE AT STA. 480-620

DETAIL V B

ITEM	DESCRIPTION	GAGE	MATERIAL	EFFECTIVITY
1	BEAM SPLICE SEGMENT		7050-T7451 PLATE MACHINED	B
2	UPPER CHORD SPLICE ANGLE		BAC1503-100274 7075-T6511	B
3	LOWER CHORD SPLICE ANGLE		BAC1514-1083 7075-T6511	B

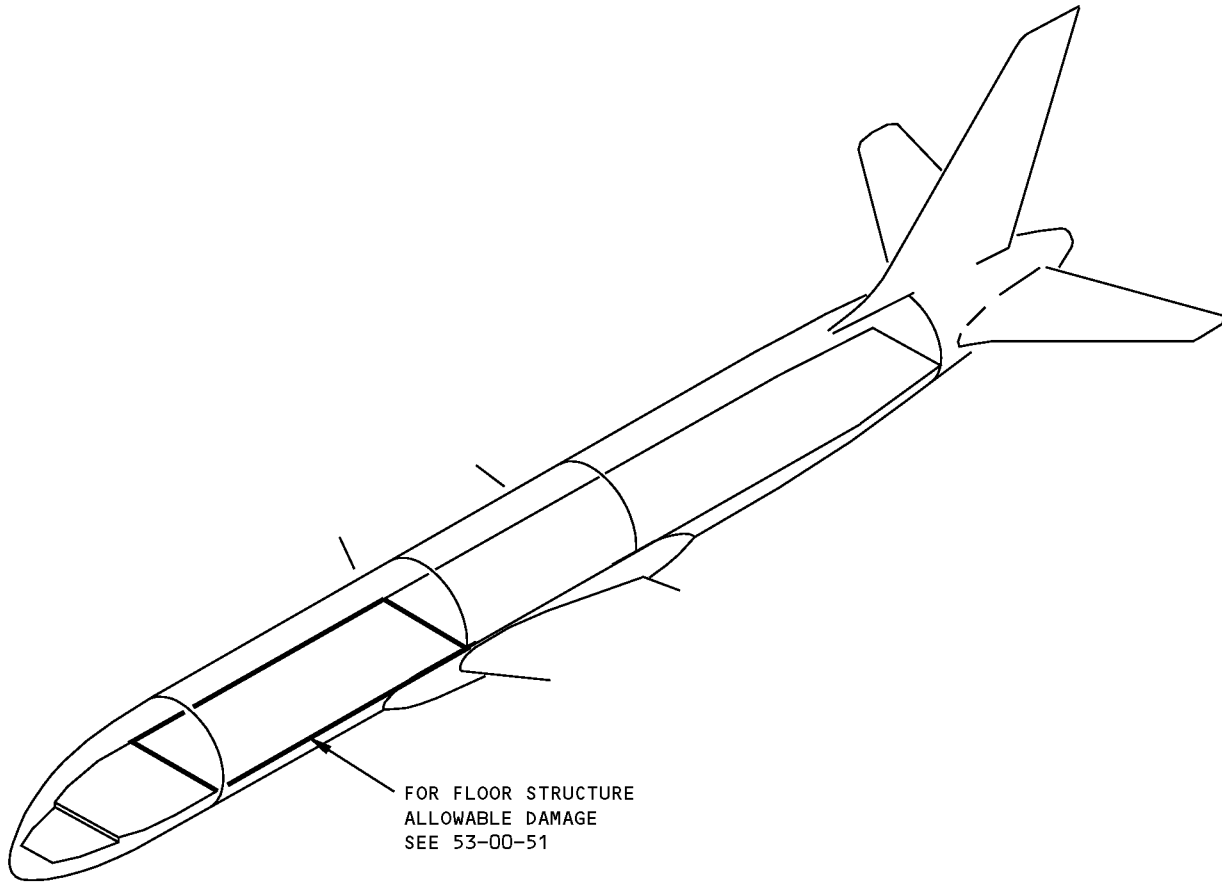
LIST OF MATERIALS FOR DETAIL V

**Section 43 Main Deck Floor Structure Identification
Figure 1 (Sheet 9 of 9)**



757-200
STRUCTURAL REPAIR MANUAL

ALLOWABLE DAMAGE GENERAL - SECTION 43 - MAIN DECK FLOOR STRUCTURE



Section 43 Main Deck Floor Structure Allowable Damage
Figure 101

D634N201

ALLOWABLE DAMAGE GENERAL
53-30-51
Page 101
Jan 20/2005



757-200

STRUCTURAL REPAIR MANUAL

REPAIR GENERAL - SECTION 43 - MAIN DECK FLOOR STRUCTURE

SERVICE BULLETIN REPAIRS

The following service bulletins contain floor structure repairs which are available for use where specific damage has been encountered. Usually, the service bulletin also covers preventive modification data which operators are encouraged to use to eliminate the need for repair.

DAMAGED AREA	CUM LINE NUMBER EFFECTIVITY A	SB NUMBER
FUSELAGE - FLOOR BEAM STABILIZATION - BS 660 TO 680, LBL 24.75 AND LBL 45.50	53, 55, 59, 60, 62, 68, 69, 70, 72, 82, 83, 86, 88, 104, 105, 107, 108, 109, 110, 119, 121, 122, 124, 131, 136, 137, 140, 152, 156, 185, 188, 190, 192, 194, 196	757-53-0049

A FOR AIRPLANES ON WHICH PREVENTIVE MODIFICATION HAS NOT BEEN ACCOMPLISHED

Section 43 Main Deck Floor Structure Repairs and Service Bulletin Repair Chart
Figure 201 (Sheet 1 of 2)

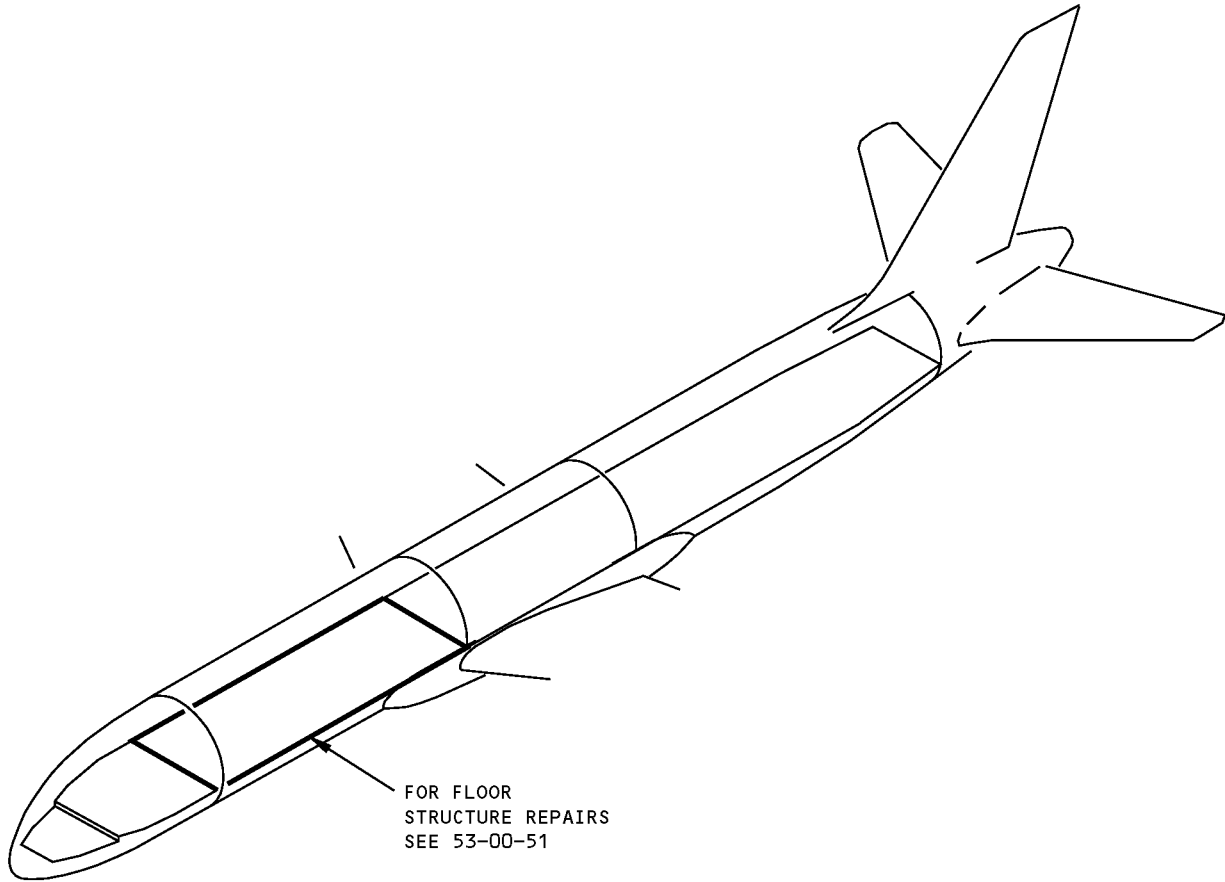
D634N201

53-30-51

REPAIR GENERAL
Page 201
Jan 20/2005



757-200
STRUCTURAL REPAIR MANUAL



Section 43 Main Deck Floor Structure Repairs and Service Bulletin Repair Chart
Figure 201 (Sheet 2 of 2)

D634N201

53-30-51

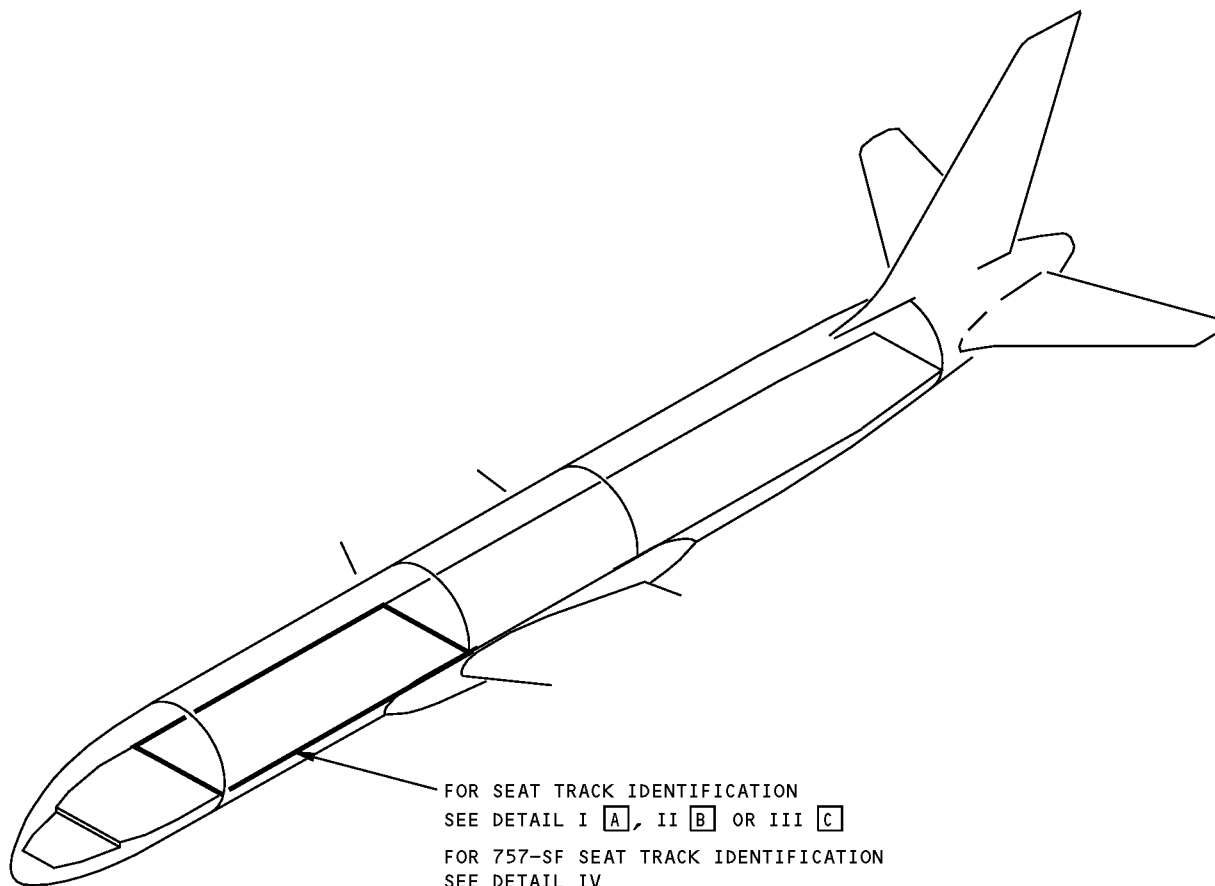
REPAIR GENERAL
Page 202
Jan 20/2005



757-200
STRUCTURAL REPAIR MANUAL

IDENTIFICATION 1 - SECTION 43 - SEAT TRACKS

REFERENCE DRAWING
143N5080



FOR SEAT TRACK IDENTIFICATION
SEE DETAIL I **A**, II **B** OR III **C**
FOR 757-SF SEAT TRACK IDENTIFICATION
SEE DETAIL IV

NOTES

- A** FOR CUM LINE NUMBERS:
1 THRU 5
- B** FOR CUM LINE NUMBERS:
9,10,11,13,16,17,24,27,29,31,34 THRU 37,
39,41,87,88,93, (BOEING REF: NA2200-NA399)
- C** ALL AIRPLANES EXCEPT FOR **A** AND **B**
- D** FOR CUM LINE NUMBERS:
6,7,8

Section 43 Seat Track Identification
Figure 1 (Sheet 1 of 5)

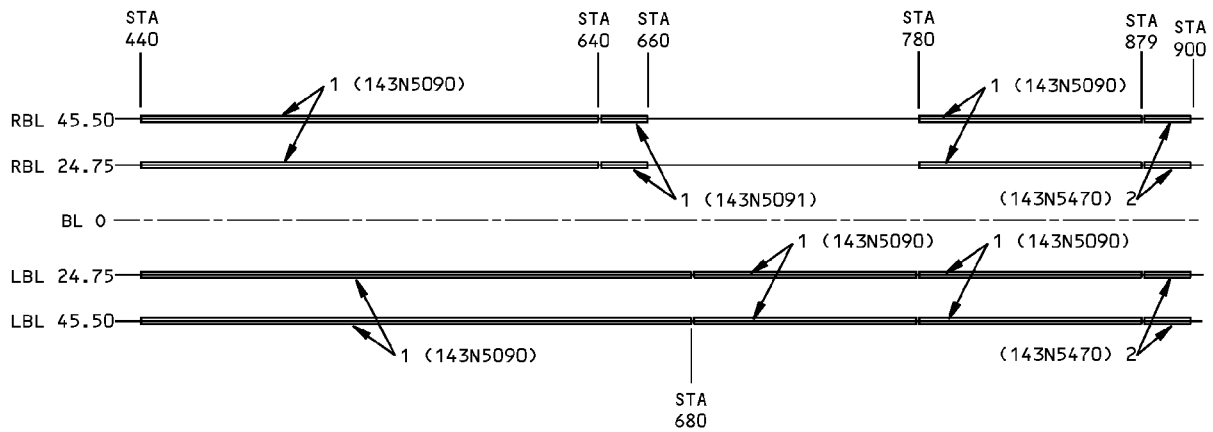
D634N201

53-30-52

IDENTIFICATION 1
Page 1
Jan 20/2005

**757-200
STRUCTURAL REPAIR MANUAL**

REF DWG
143N5080



DETAIL I A

ITEM	DESCRIPTION	GAGE	MATERIAL	EFFECTIVITY
1	SEAT TRACK		BAC1520-792 7178-T6511	
2	SEAT TRACK SUPPORT		BAC1520-792 (ALTERED) 7178-T6511 BAC1508-129 7178-T6511	

LIST OF MATERIALS FOR DETAIL I

**Section 43 Seat Track Identification
Figure 1 (Sheet 2 of 5)**

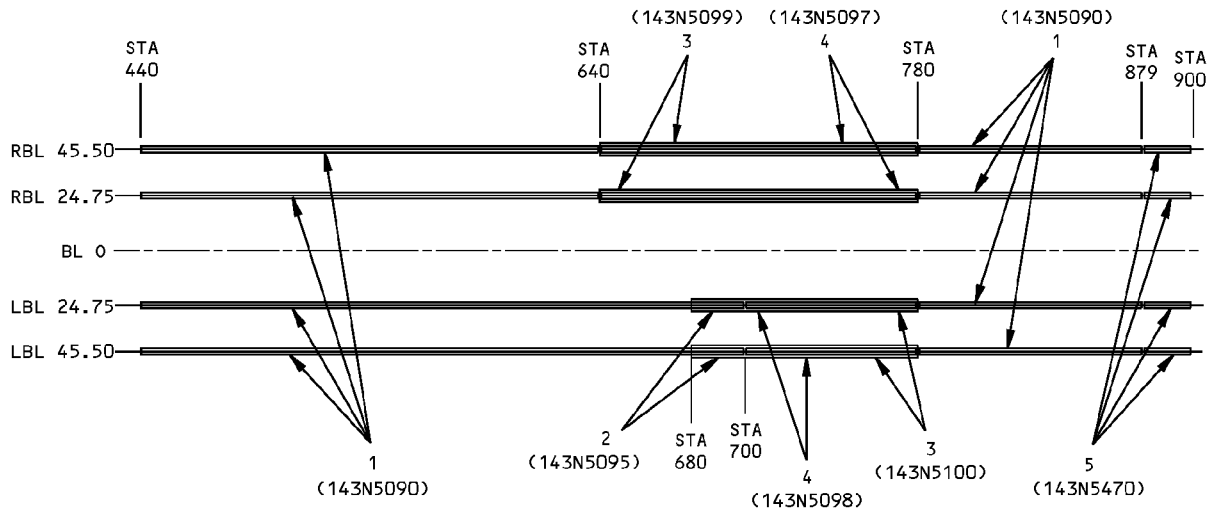
IDENTIFICATION 1
Page 2
Jan 20/2005

53-30-52

D634N201

**757-200
STRUCTURAL REPAIR MANUAL**

REF DWG
143N5080



DETAIL II B

ITEM	DESCRIPTION	GAGE	MATERIAL	EFFECTIVITY
1	SEAT TRACK		BAC1520-792 7178-T6511	
2	SEAT TRACK	0.48	CRES 15-5 PH	
3	FILLER	0.50	7075-T6511	
4	SUPPORT		BAC1508-237 7075-T6511	
5	SEAT TRACK SUPPORT		BAC1520-792 (ALTERED) 7178-T6511 BAC1508-129 7178-T6511	

LIST OF MATERIALS FOR DETAIL II

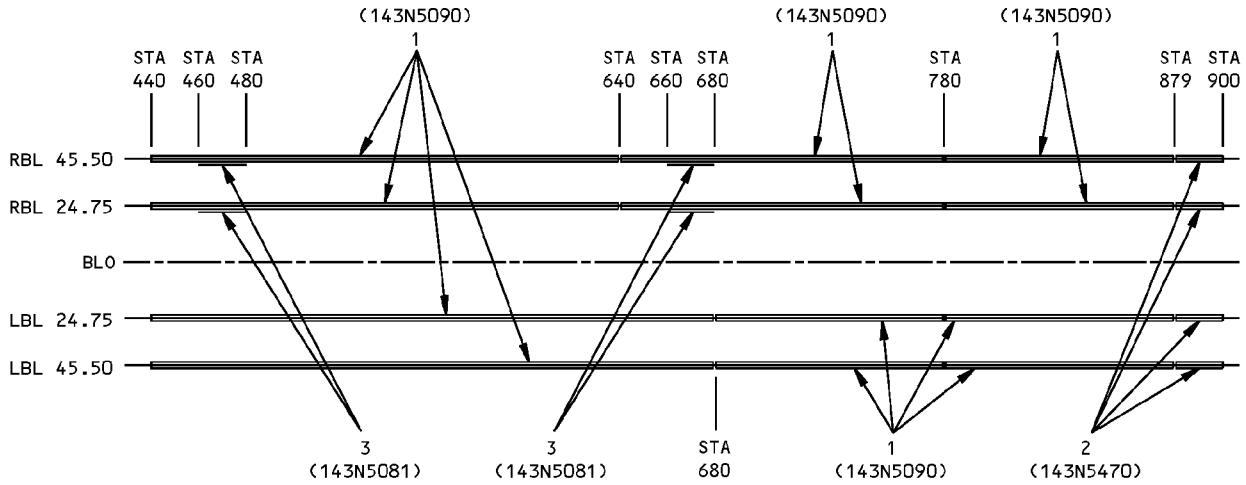
**Section 43 Seat Track Identification
Figure 1 (Sheet 3 of 5)**

IDENTIFICATION 1
Page 3
Jan 20/2005

53-30-52

D634N201

**757-200
STRUCTURAL REPAIR MANUAL**



DETAIL III C

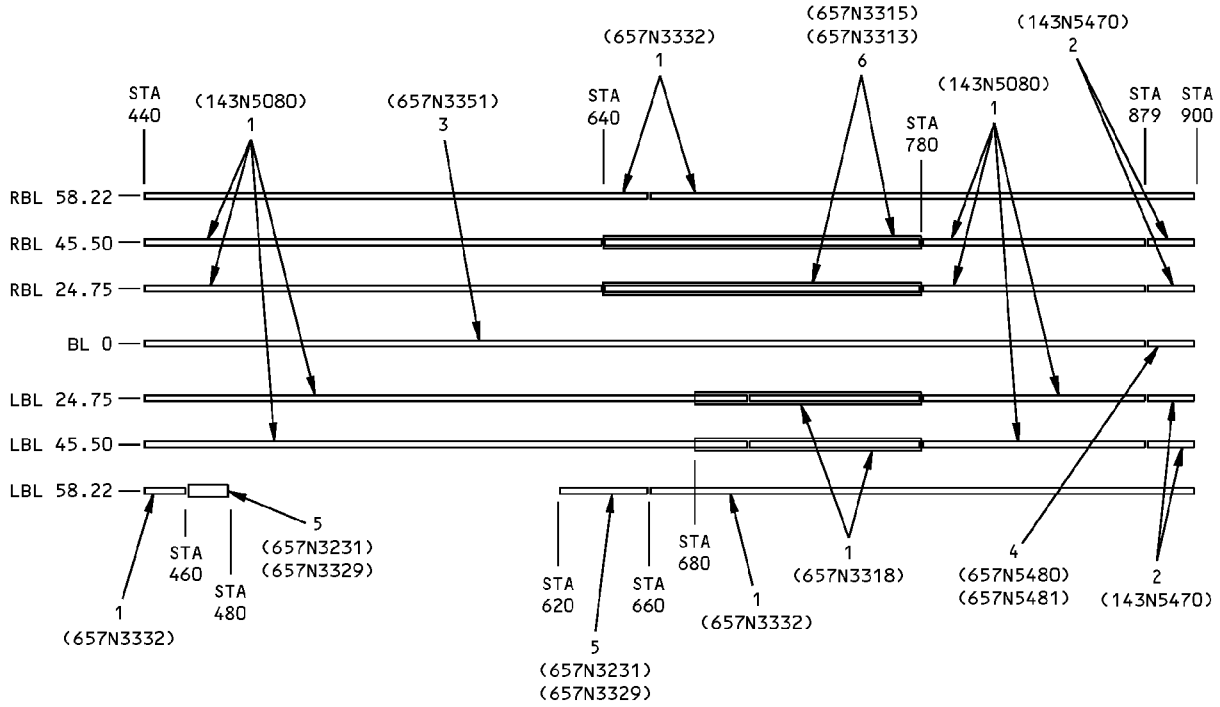
ITEM	DESCRIPTION	GAGE	MATERIAL	EFFECTIVITY
1	SEAT TRACK		BAC1520-792 7178-T6511	
2	SEAT TRACK SUPPORT		BAC1520-792 (ALTERED) 7178-T6511 BAC1508-129 7178-T6511	
3	REINFORCING ANGLE (LOWER FLANGE)		BAC1503-100620 7178-T6511	D

LIST OF MATERIALS FOR DETAIL III

**Section 43 Seat Track Identification
Figure 1 (Sheet 4 of 5)**

**757-200
STRUCTURAL REPAIR MANUAL**

REFERENCE DRAWING
143N5080
657N3311
657N3321
657N3351



DETAIL IV

ITEM	DESCRIPTION	GAGE	MATERIAL	EFFECTIVITY
1	SEAT TRACK		BAC1520-792 7178-T6511	
2	SEAT TRACK SUPPORT		BAC1520-792 (ALTERED) 7178-T6511 BAC1508-129 7178-T6511	
3	SEAT TRACK		BAC1520-2474 7075-T6511	
4	SEAT TRACK CROWN SUPPORT		BAC1520-841 7178-T6511 BAC1508-240 7178-T6511	
5	SEAT TRACK CROWN SUPPORT		CRES 15-5 PH HTRR 180-200KSI BAC1508-237 7075-T6511	
6	SEAT TRACK CROWN SUPPORT		CRES 15-5 PH HTRR 180-200KSI BAC1508-240 7075-T6511	

LIST OF MATERIALS FOR DETAIL IV

**Section 43 Seat Track Identification
Figure 1 (Sheet 5 of 5)**

IDENTIFICATION 1
Page 5
Jan 20/2005

53-30-52

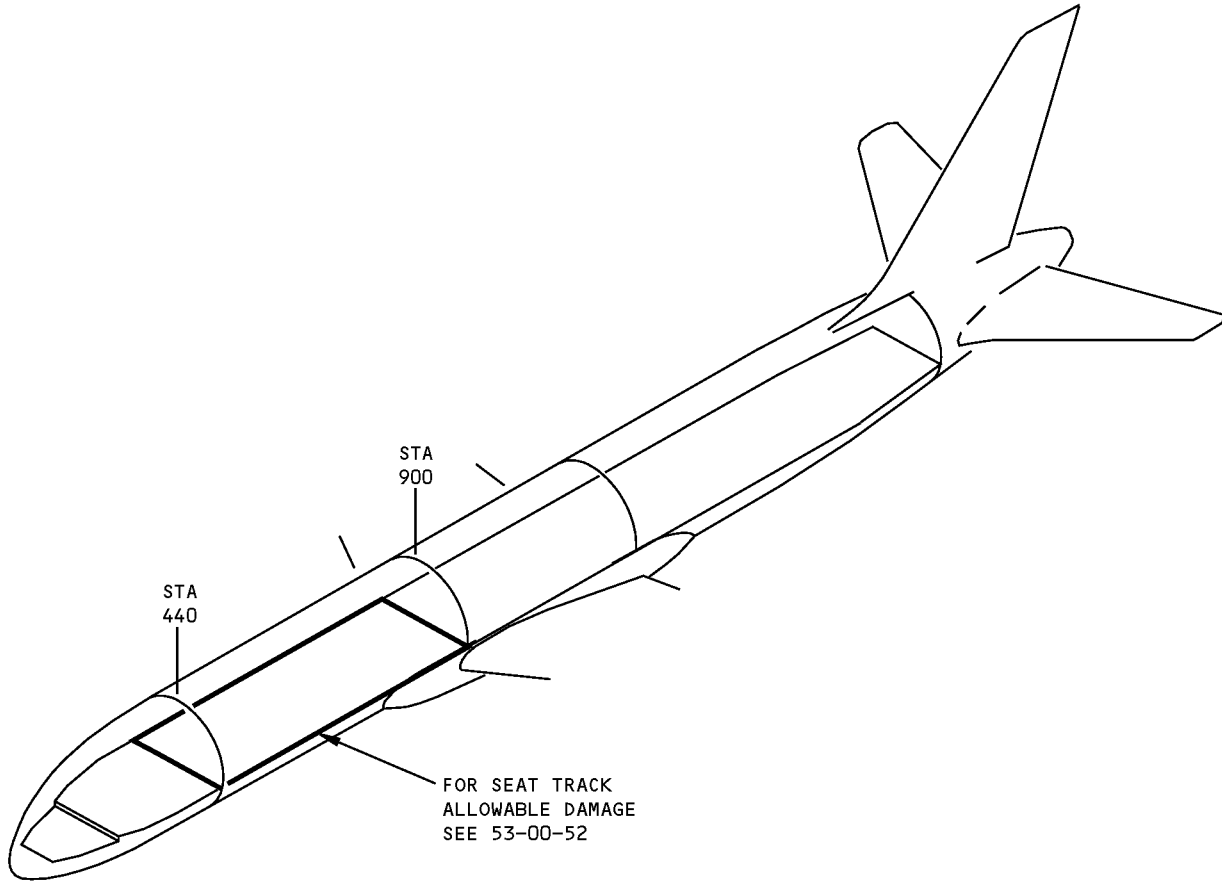
D634N201



757-200
STRUCTURAL REPAIR MANUAL

ALLOWABLE DAMAGE GENERAL - SECTION 43 - SEAT TRACKS

REF DWG
143N5080



Section 43 Seat Track Allowable Damage
Figure 101

D634N201

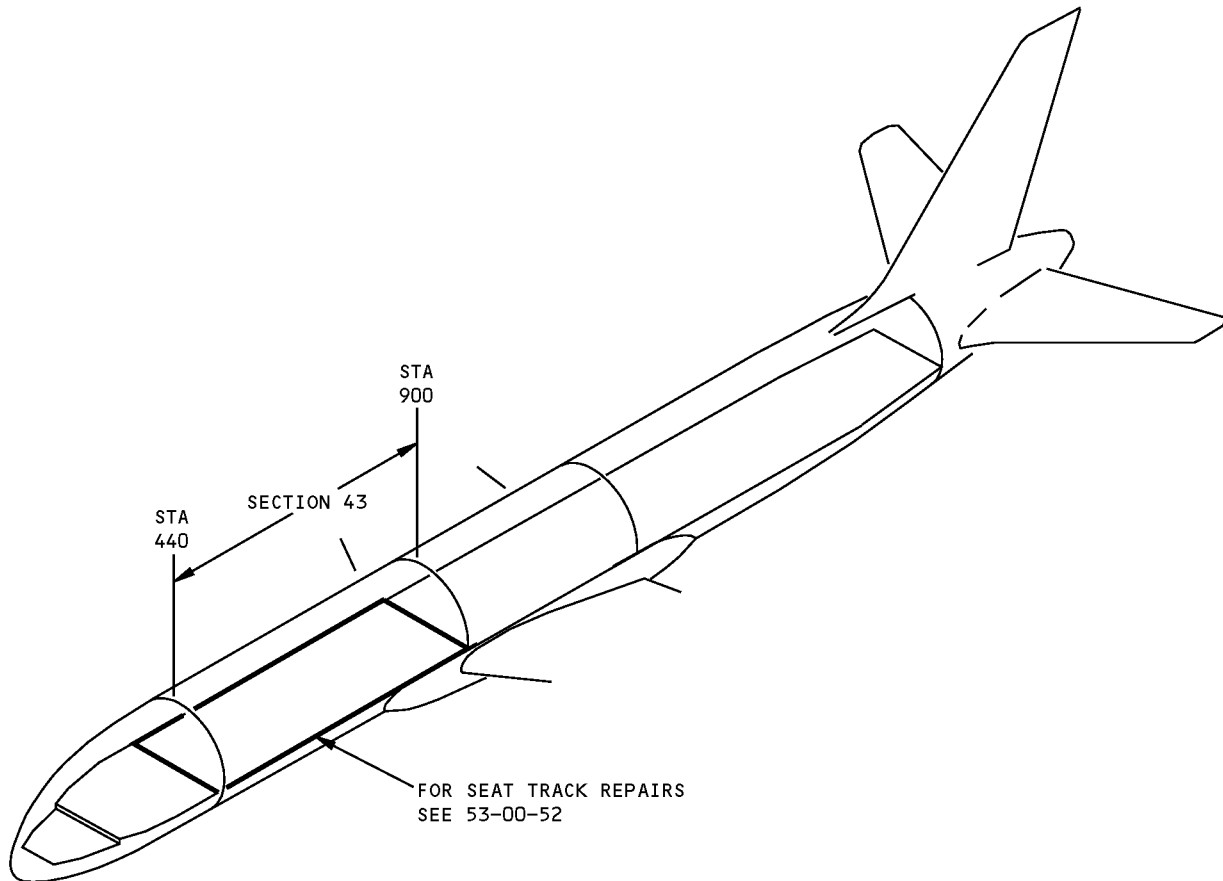
ALLOWABLE DAMAGE GENERAL
53-30-52
Page 101
Jan 20/2005



757-200
STRUCTURAL REPAIR MANUAL

REPAIR GENERAL - SECTION 43 - SEAT TRACKS

REF DWG
143N5080



Section 43 Seat Track Repair
Figure 201

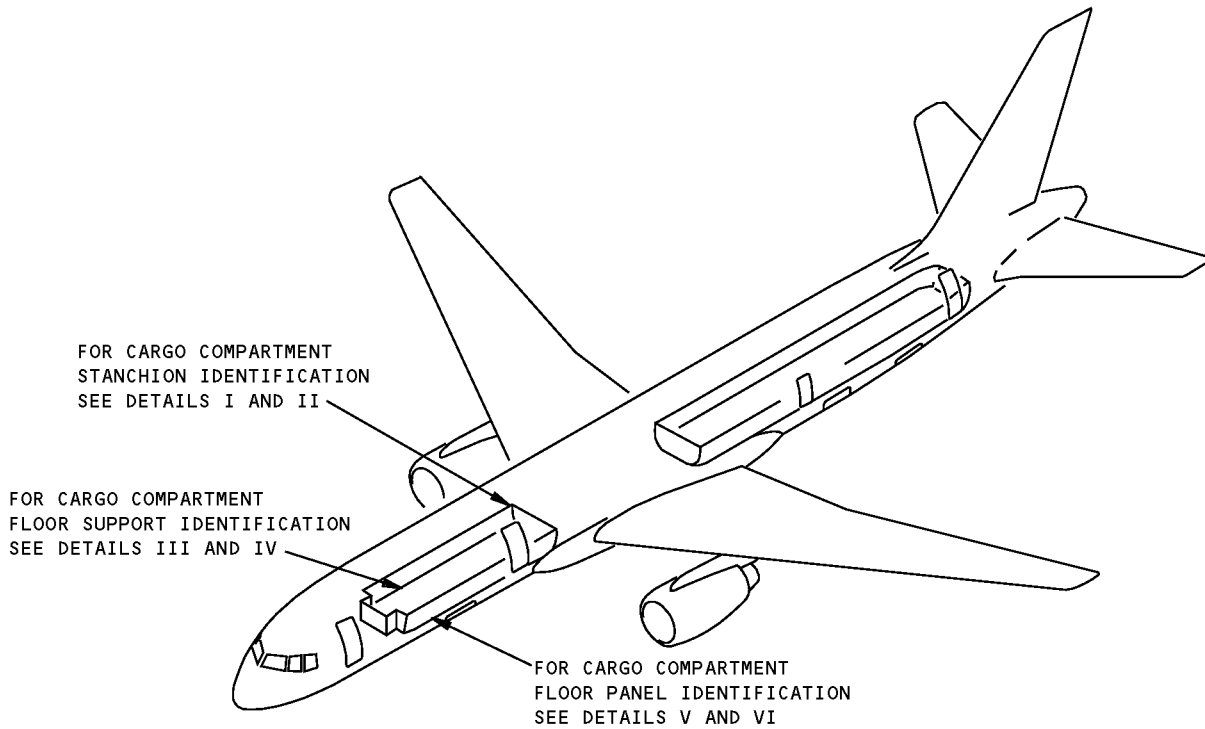
D634N201

53-30-52

REPAIR GENERAL
Page 201
Jan 20/2005

757-200
STRUCTURAL REPAIR MANUAL

IDENTIFICATION 1 - SECTION 43 - CARGO COMPARTMENT STRUCTURE



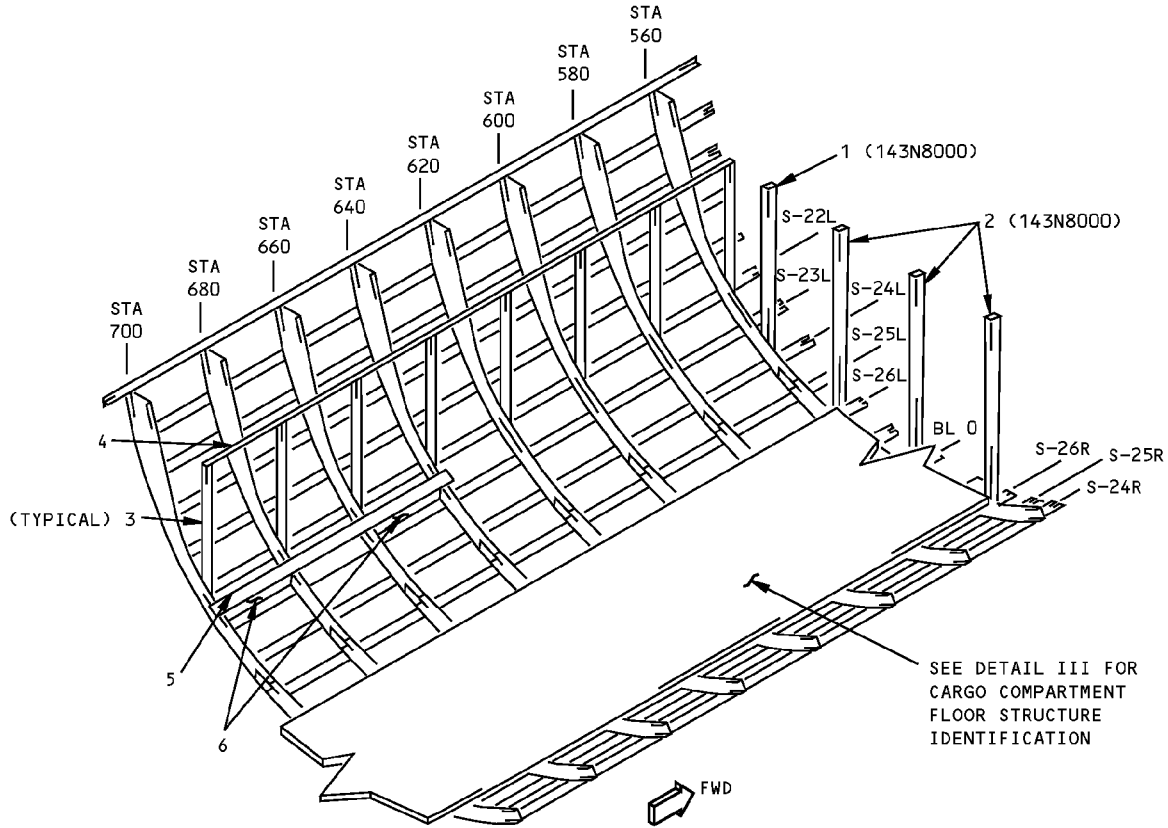
NOTES

- A** CARGO COMPARTMENT FLOOR STRUCTURE HAS MANY CONFIGURATIONS. SEE ENGINEERING DRAWINGS FOR APPROPRIATE CONFIGURATION
- B** THICKER DECK PLATES AVAILABLE AS AN OPERATOR OPTION

**Section 43 Cargo Compartment Structure Identification
Figure 1 (Sheet 1 of 7)**

**757-200
STRUCTURAL REPAIR MANUAL**

REF DWG
453N1131



**CARGO COMPARTMENT STANCHION IDENTIFICATION
(SYMMETRICAL ABOUT BL 0)
DETAIL I**

ITEM	DESCRIPTION	GAGE	MATERIAL	EFFECTIVITY
1	STANCHION		AND10140-1202 7075-T6511	
2	STANCHION		AND10140-2402 7075-T6511	
3	STANCHION		GRAPHITE-EPOXY LAMINATE (VENDOR SUPPLIED)	
4	CLOSURE PANEL	0.050	2024-T3	
5	SUPPORT TRACK		BAC1519-149 7075-T6511	
6	INTERCOSTAL	0.063	CLAD 7075-T6	

LIST OF MATERIALS FOR DETAIL I

**Section 43 Cargo Compartment Structure Identification
Figure 1 (Sheet 2 of 7)**

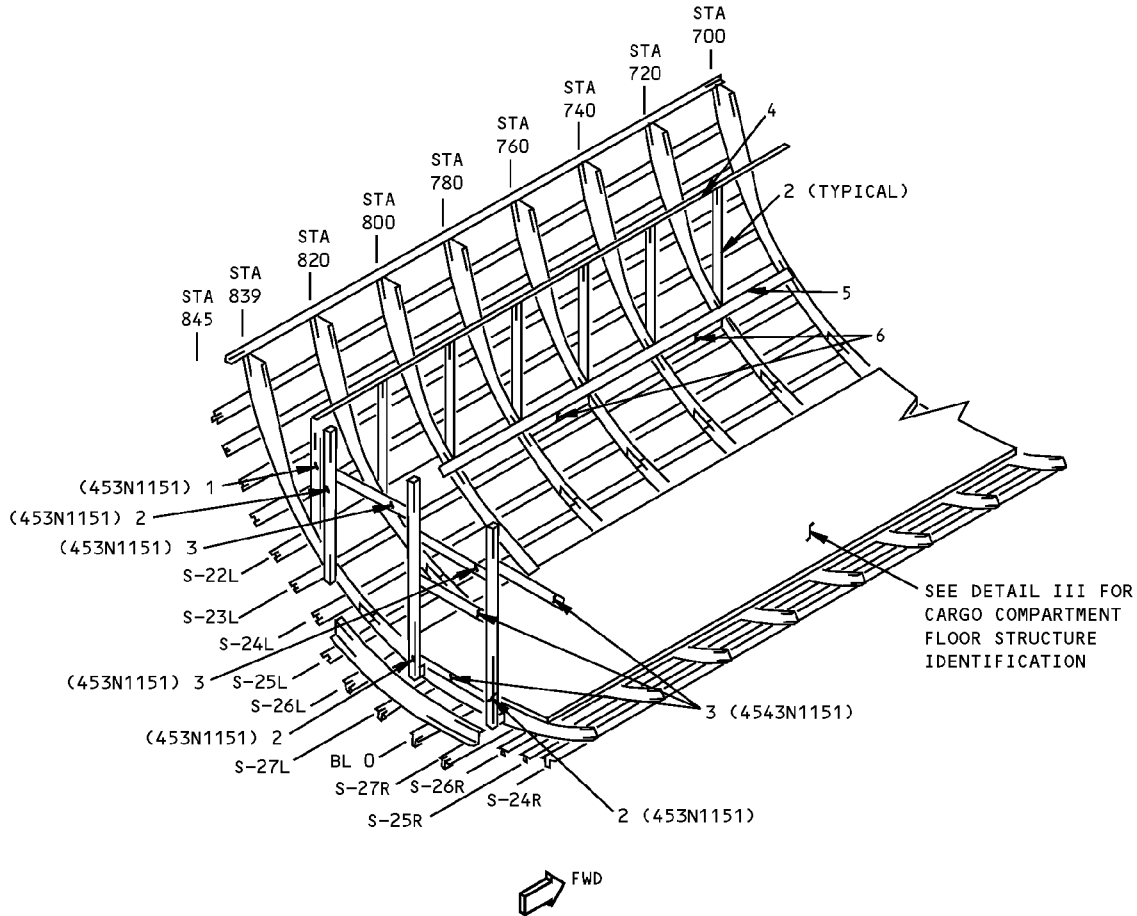
IDENTIFICATION 1
Page 2
Jan 20/2005

53-30-53

D634N201

**757-200
STRUCTURAL REPAIR MANUAL**

REF DWG
453N1131



**CARGO COMPARTMENT STANCHION IDENTIFICATION
(SYMMETRICAL ABOUT BL 0 EXCEPT WHERE NOTED)
DETAIL II**

ITEM	DESCRIPTION	GAGE	MATERIAL	EFFECTIVITY
1	ANGLE		BAC1490-2653 7075-T6	
2	STANCHION		GRAPHITE-EPOXY LAMINATE (VENDOR SUPPLIED)	
3	SUPPORT TEE		AND10141-1403 7075-T6511	
4	CLOSURE PANEL	0.050	2024-T3	
5	SUPPORT TRACK		BAC1519-149 7075-T6511	
6	INTERCOSTAL	0.063	CLAD 7075-T6	

LIST OF MATERIALS FOR DETAIL II

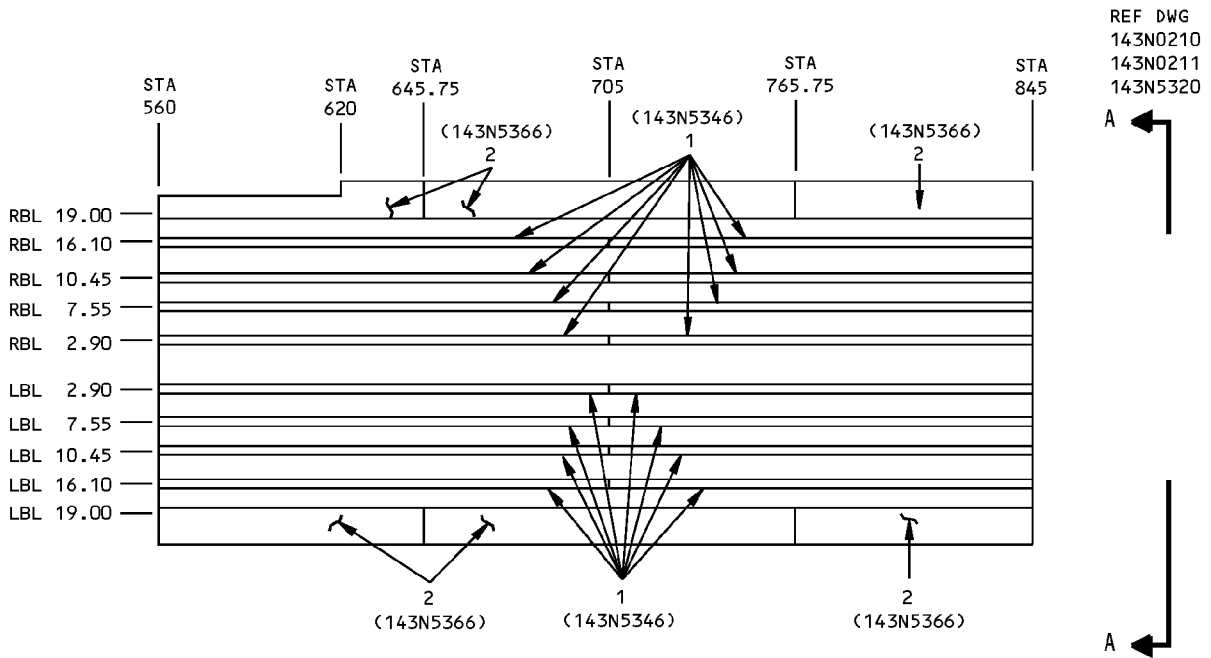
**Section 43 Cargo Compartment Structure Identification
Figure 1 (Sheet 3 of 7)**

IDENTIFICATION 1
Page 3
Jan 20/2005

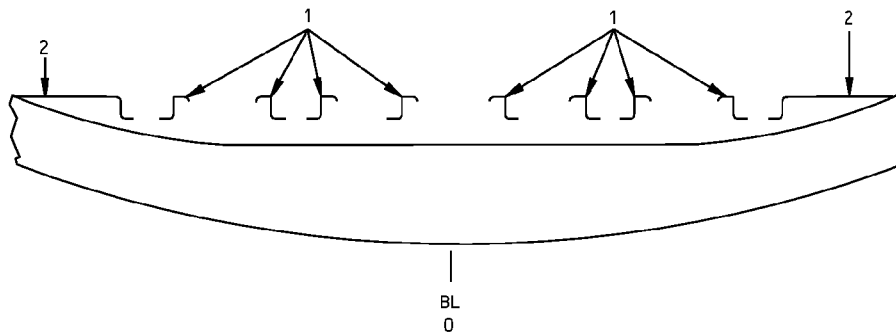
53-30-53

D634N201

**757-200
STRUCTURAL REPAIR MANUAL**



**CARGO COMPARTMENT FLOOR SUPPORT IDENTIFICATION
DETAIL III A**



SECTION A-A (ROTATED 90°)

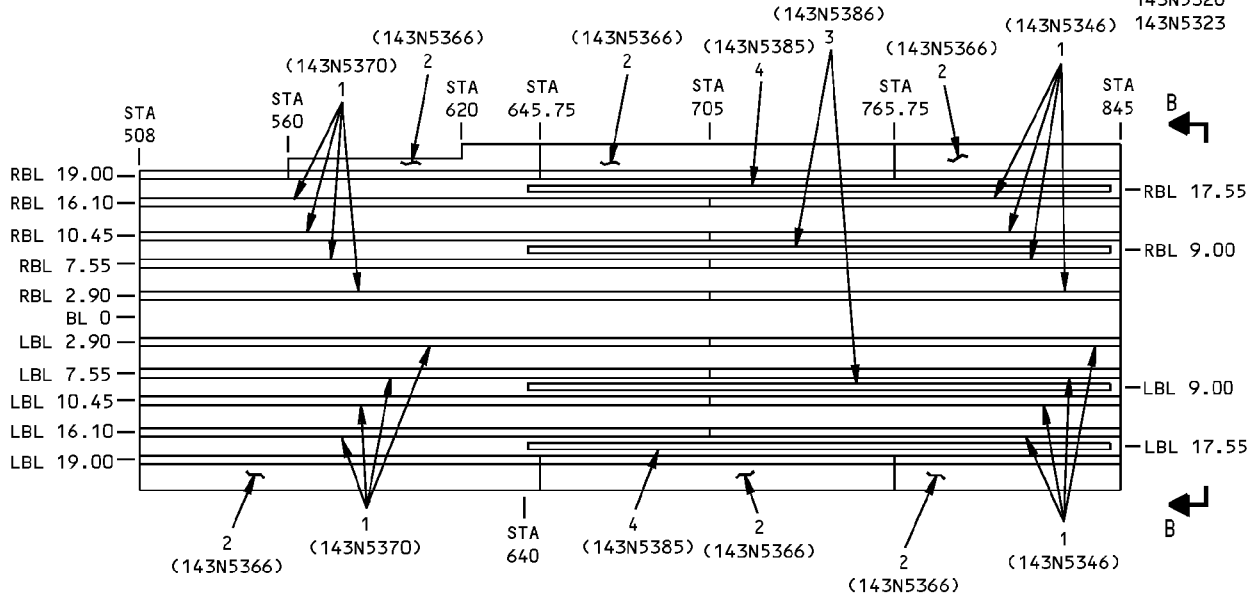
ITEM	DESCRIPTION	GAGE	MATERIAL	EFFECTIVITY
1	STRINGER		BAC1517-2229 7075-T6	
2	SIDE PANEL	0.063	CLAD 7075-T6	

LIST OF MATERIALS FOR DETAIL III

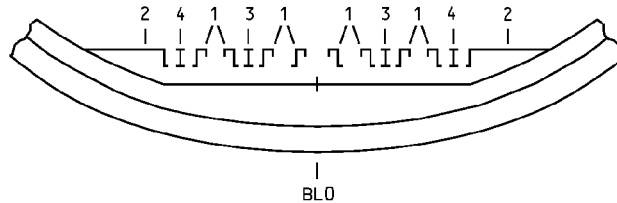
**Section 43 Cargo Compartment Structure Identification
Figure 1 (Sheet 4 of 7)**

**757-200
STRUCTURAL REPAIR MANUAL**

REF DWG
143N0210
143N0211
143N5320
143N5323



**CARGO COMPARTMENT FLOOR SUPPORT IDENTIFICATION
DETAIL IV [A]**



SECTION B-B (ROTATED 90°)

ITEM	DESCRIPTION	GAGE	MATERIAL	EFFECTIVITY
1	STRINGER		BAC1517-2226 7075-T6511	
2	SIDE PANEL	0.063	CLAD 7075-T6	
3	BEAM		AND10140-1401 7075-T6511	
4	BEAM		BAC1518-893 7075-T6511 OPTIONAL: BAC1518-300	

LIST OF MATERIALS FOR DETAIL IV

**Section 43 Cargo Compartment Structure Identification
Figure 1 (Sheet 5 of 7)**

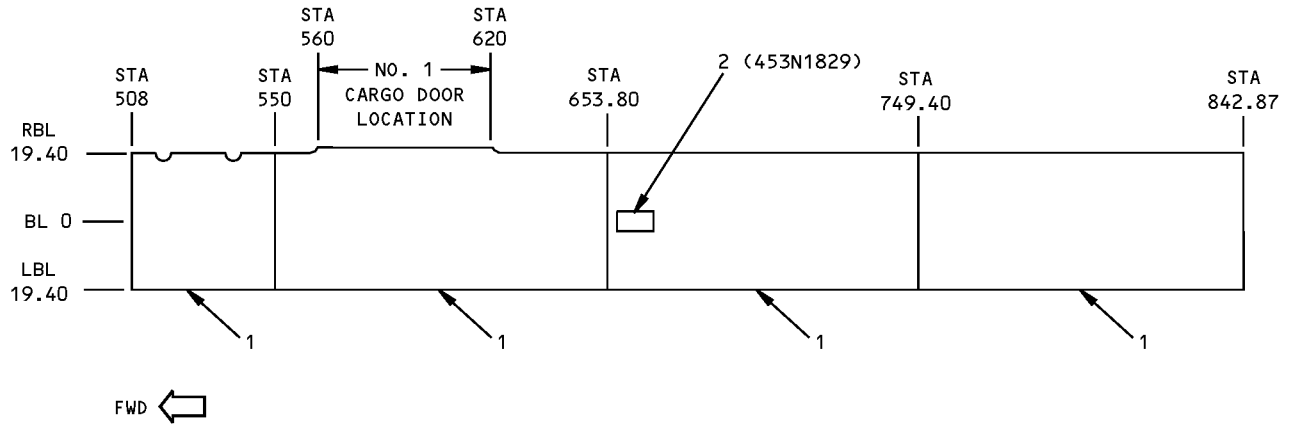
IDENTIFICATION 1
Page 5
Jan 20/2005

53-30-53

D634N201

**757-200
STRUCTURAL REPAIR MANUAL**

REF DWG
453N1170



DECK PLATE LOCATIONS FOR AIRPLANES WITHOUT ACE BAGGAGE LOADER
DETAIL V

ITEM	DESCRIPTION	GAGE	MATERIAL	EFFECTIVITY
1	DECK PLATE	0.050	CLAD 2024-T3	
		0.071	CLAD 2024-T3 B	
2	ACCESS PANEL	0.050	2024-T3	

LIST OF MATERIALS FOR DETAIL V

**Section 43 Cargo Compartment Structure Identification
Figure 1 (Sheet 6 of 7)**

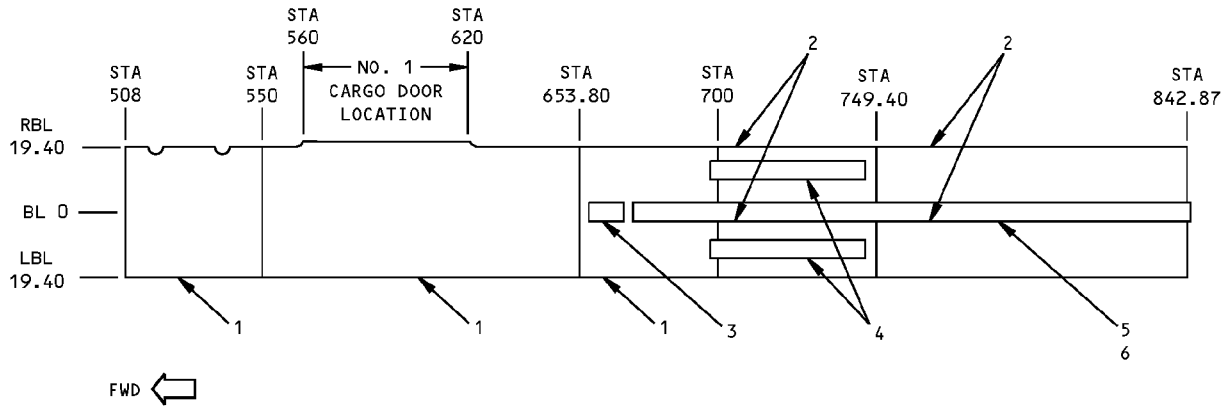
IDENTIFICATION 1
Page 6
Jan 20/2005

53-30-53

D634N201

**757-200
STRUCTURAL REPAIR MANUAL**

REF DWG
453N1170



**DECK PLATE LOCATIONS FOR AIRPLANES HAVING ACE BAGGAGE LOADER
DETAIL VI**

ITEM	DESCRIPTION	GAGE	MATERIAL	EFFECTIVITY
1	DECK PLATE	0.050 0.071	CLAD 2024-T3 CLAD 2024-T3	
2	DECK PLATE	0.020	CLAD 2024-T3	
3	ACCESS PANEL	0.050	2024-T3	
4	PAN	0.040	2024-T42 OR FIBERGLASS/EPOXY LAMINATE PER BMS 8-80, TYPE II, CLASS I	
5	PAN ASSY CHANNEL PLATE END PLATE	0.032 0.032 0.032	6061-T4 CLAD 2024-T3 6061-T4	
6	PAN		FIBERGLASS/EPOXY LAMINATE PER BMS 8-80, TYPE II, CLASS I	

LIST OF MATERIALS FOR DETAIL VI

**Section 43 Cargo Compartment Structure Identification
Figure 1 (Sheet 7 of 7)**

IDENTIFICATION 1
Page 7
Jan 20/2005

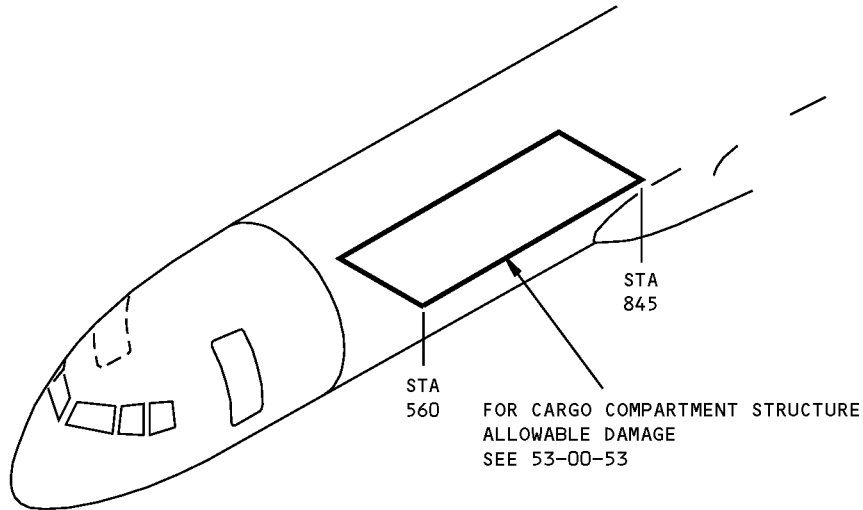
53-30-53

D634N201



757-200
STRUCTURAL REPAIR MANUAL

ALLOWABLE DAMAGE GENERAL - SECTION 43 - CARGO COMPARTMENT STRUCTURE



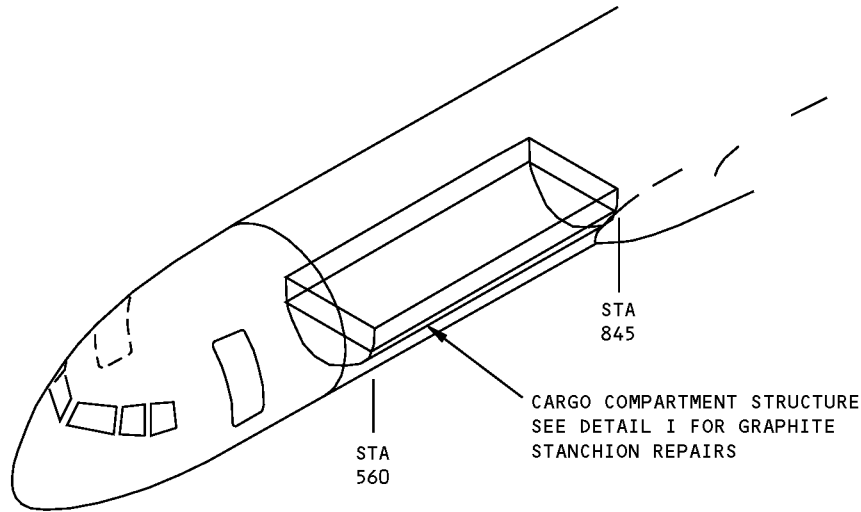
Section 43 Cargo Compartment Structure Allowable Damage
Figure 101

D634N201

ALLOWABLE DAMAGE GENERAL
53-30-53 Page 101
Jan 20/2005

**757-200
STRUCTURAL REPAIR MANUAL**

REPAIR GENERAL - SECTION 43 - CARGO COMPARTMENT STRUCTURE

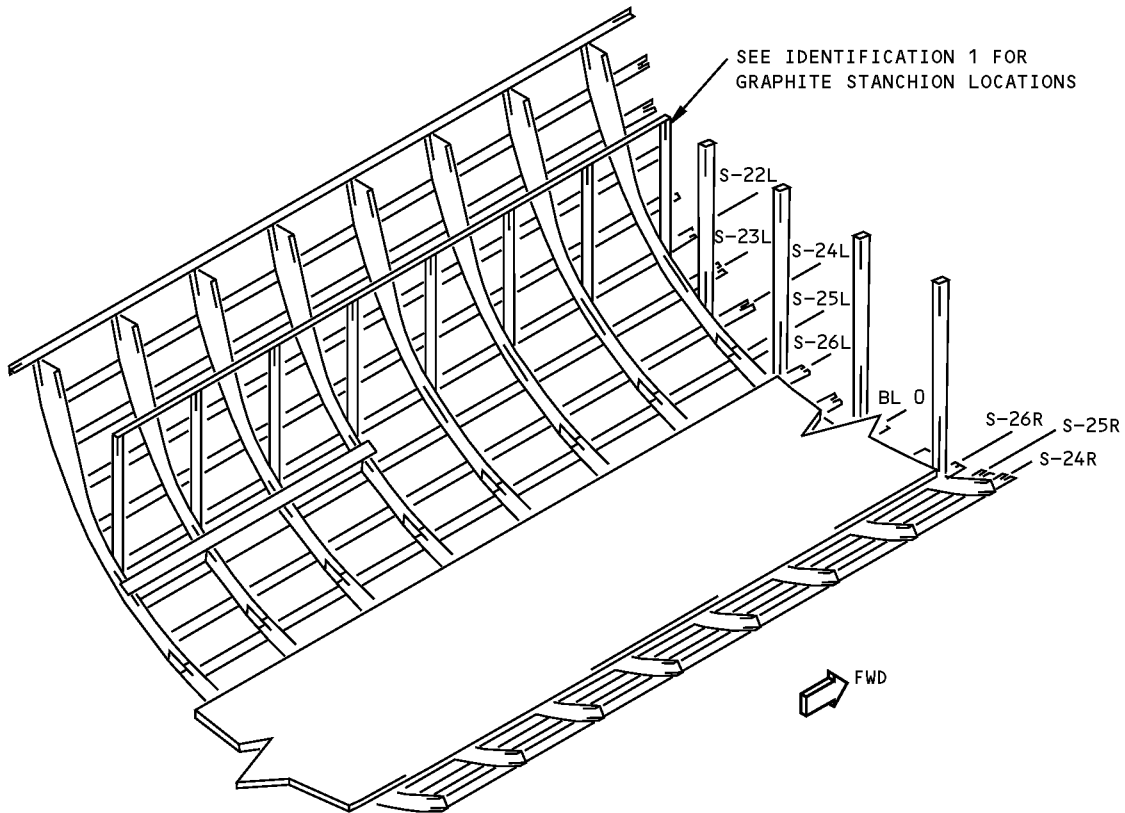


NOTES

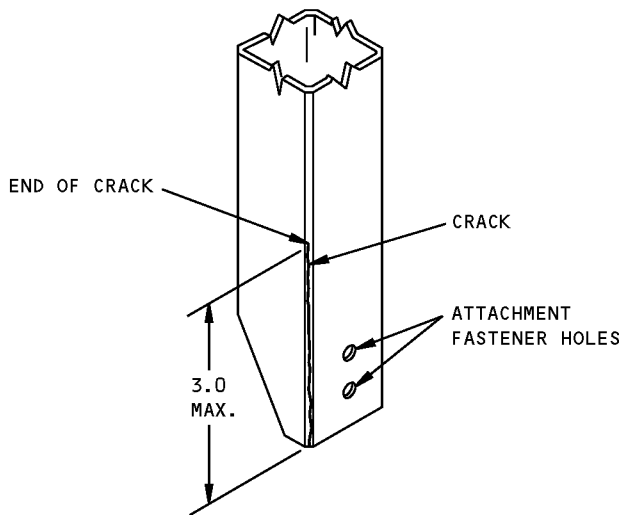
- THIS IS A CATEGORY A REPAIR FOR 757-SF AIRPLANES. THE INSPECTIONS GIVEN IN THE MAINTENANCE PLANNING DATA (MPD) ARE SUFFICIENT TO MAINTAIN THE DAMAGE TOLERANCE OF THE INITIAL STRUCTURE WITH THIS REPAIR INSTALLED. REFER TO SRM 51-00-06 FOR REPAIR CATEGORIES AND DEFINITIONS.
- REFER TO AMM 25-50-09 FOR REPAIRS TO THE CARGO SIDEWALL LINER. THE LINERS PROVIDE A FIRE AND SMOKE BARRIER
- REFER TO SRM 51-70-11 FOR FORMED SECTION REPAIR
- REFER TO SRM 51-70-12 FOR EXTRUDED SECTION REPAIR
- REFER TO SRM 51-70-13 FOR WEB REPAIRS
- FITTING REPAIRS ARE NOT PERMITTED
- A CRACK REPAIR TO GRAPHITE STANCHIONS IS PERMITTED IF, THE CRACK IS LOCATED IN A CORNER AND THE CRACK LENGTH DOES NOT EXCEED A MAXIMUM OF 3.0 INCHES (75 mm)
- REPAIR GRAPHITE STANCHIONS AS GIVEN IN SRM 51-70-03, PARAGRAPH 5.P. ONLY IF THESE CONDITIONS ARE MET
- AT THE NEXT "C" CHECK, REPLACE ANY DAMAGED GRAPHITE STANCHION WITH A NEW STANCHION MADE OF GRAPHITE OR ALUMINUM MATERIAL
- STANCHIONS WITH DAMAGE EXCEEDING THE LIMITS AS GIVEN MUST BE REPLACED

**Section 43 Cargo Compartment Structure Repair
Figure 201 (Sheet 1 of 2)**

**757-200
STRUCTURAL REPAIR MANUAL**



TYPICAL CARGO COMPARTMENT STRUCTURE



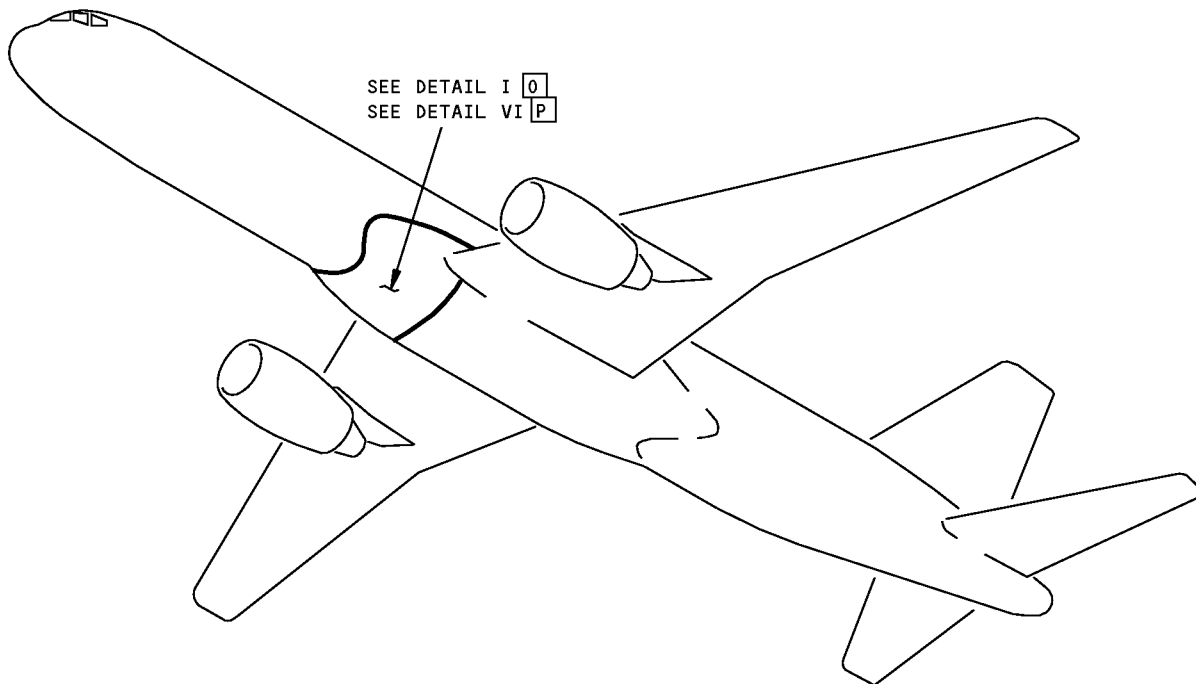
TYPICAL GRAPHITE STANCHION

GRAPHITE STANCHION REPAIR
DETAIL I

**Section 43 Cargo Compartment Structure Repair
Figure 201 (Sheet 2 of 2)**

**757-200
STRUCTURAL REPAIR MANUAL**

IDENTIFICATION 1 - SECTION 43 - WING-TO-BODY FAIRING SKINS



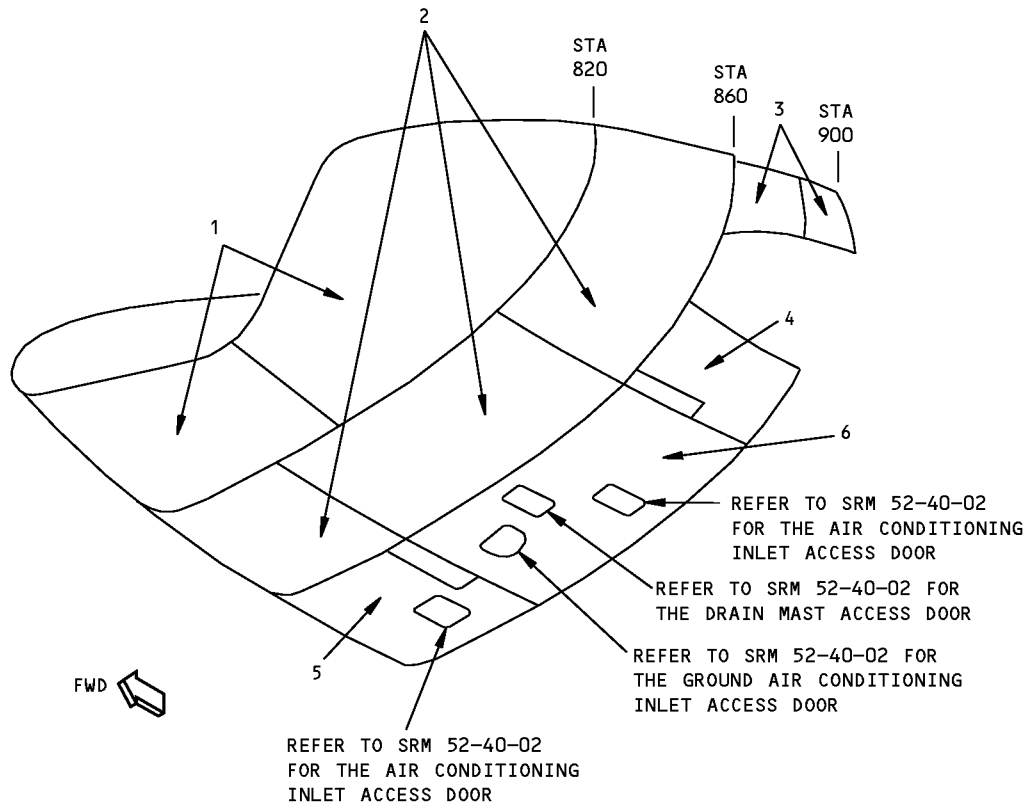
NOTES

- | | |
|--|--|
| <p>A PLY ORIENTATION CONVENTION, DEGREES INDICATED, IS PARALLEL TO THE FABRIC WARP DIRECTION</p> <p>B MATERIAL AND PLY ORIENTATION SHOWN FOR FIELD AREAS ONLY. SEE BOEING DRAWINGS FOR EDGE BANDS AND AREAS WITH DOUBLERS</p> <p>C DIAGRAM OF PLY ORIENTATION, SEE PLY TABLE FOR PLY ORIENTATION AND MATERIAL</p> <p>D ARAMID/EPOXY FABRIC AS GIVEN IN BMS 8-219, STYLE 120, 250°F (121°C) CURE</p> <p>E GRAPHITE/EPOXY TAPE AS GIVEN IN BMS 8-168, TYPE II, CLASS I, GRADE 190, 250°F (121°C) CURE</p> <p>F GRAPHITE/EPOXY FABRIC AS GIVEN IN BMS 8-168, TYPE II, CLASS II, STYLE 3K-70-PW, 250°F (121°C) CURE</p> <p>G GRAPHITE/EPOXY TAPE AS GIVEN IN BMS 8-168, TYPE II, CLASS I, GRADE 145, 250°F (121°C) CURE</p> <p>H ALUMINUM COATED FIBERGLASS AS GIVEN IN BMS 8-278, TYPE II, CLASS 250, 250°F (121°C) CURE</p> <p>I ARAMID/EPOXY FABRIC AS GIVEN IN BMS 8-219, STYLE 285, 250°F (121°C) CURE</p> | <p>J FIBERGLASS/EPOXY FABRIC AS GIVEN IN BMS 8-79, STYLE 120, CLASS III, GRADE B, 250°F (121°C) CURE</p> <p>K FOR CUM LINE NUMBERS: 168 AND ON</p> <p>L ALUMINUM COATED FIBERGLASS AS GIVEN IN BMS 8-278, TYPE I, CLASS 250, 250°F (121°C) CURE</p> <p>M FOR CUM LINE NUMBERS: 1 THRU 193</p> <p>N FOR CUM LINE NUMBERS: 194 AND ON</p> <p>O FOR CUM LINE NUMBERS: 1 THRU 1029</p> <p>P FOR CUM LINE NUMBERS: 1041, 1044 THRU 1050</p> <p>Q FIBERGLASS/EPOXY FABRIC AS GIVEN IN BMS 8-79, STYLE 220, CLASS III, GRADE B (OPTIONAL: STYLE 120)</p> <p>R EXPANDED ALUMINUM FOIL AS GIVEN IN BMS 8-336, TYPE I, CLASS 1, GRADE 016</p> |
|--|--|

**Section 43 Wing-to-Body Fairing Skin Identification
Figure 1 (Sheet 1 of 12)**

**757-200
STRUCTURAL REPAIR MANUAL**

REFERENCE DRAWINGS
149N7110
149N7111



DETAIL I 0

**Section 43 Wing-to-Body Fairing Skin Identification
Figure 1 (Sheet 2 of 12)**



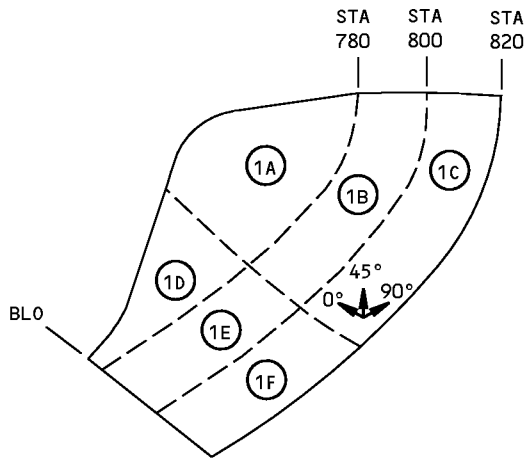
**757-200
STRUCTURAL REPAIR MANUAL**

ITEM	DESCRIPTION	GAGE	MATERIAL	EFFECTIVITY
1	SKIN PANEL SKIN CORE		ARAMID/GRAPHITE/FIBERGLASS/EPOXY HONEYCOMB SANDWICH SEE DETAIL II ARAMID HONEYCOMB AS GIVEN IN BMS 8-124, CLASS 4, TYPE V, GRADE 3.0	0
2	SKIN PANEL SKIN CORE		ARAMID/GRAPHITE/FIBERGLASS/EPOXY HONEYCOMB SANDWICH SEE DETAIL III ARAMID HONEYCOMB AS GIVEN IN BMS 8-124, CLASS 4, TYPE V, GRADE 3.0	0
3	SKIN PANEL SKIN CORE		ARAMID/GRAPHITE/FIBERGLASS/EPOXY HONEYCOMB SANDWICH SEE DETAIL IV ARAMID HONEYCOMB AS GIVEN IN BMS 8-124, CLASS 4, TYPE VI, GRADE 3.0	0
4	SKIN PANEL SKIN CORE		ARAMID/GRAPHITE/FIBERGLASS/EPOXY HONEYCOMB SANDWICH SEE DETAIL IV ARAMID HONEYCOMB AS GIVEN IN BMS 8-124, CLASS 4, TYPE V, GRADE 3.0	0
5	SKIN PANEL SKIN CORE		ARAMID/GRAPHITE/FIBERGLASS/EPOXY HONEYCOMB SANDWICH SEE DETAIL IV ARAMID HONEYCOMB AS GIVEN IN BMS 8-124, CLASS 4, TYPE V, GRADE 3.0	0
6	SKIN PANEL SKIN CORE		ARAMID/GRAPHITE/EPOXY HONEYCOMB SANDWICH SEE DETAIL V ARAMID HONEYCOMB AS GIVEN IN BMS 8-124, CLASS 4, TYPE V, GRADE 3.0	0
7	SKIN PANEL SKIN CORE		GRAPHITE/FIBERGLASS/EPOXY HONEYCOMB SANDWICH SEE DETAIL VII ARAMID HONEYCOMB AS GIVEN IN BMS 8-124, CLASS 4, TYPE V, GRADE 3.0	P
8	SKIN PANEL SKIN CORE		GRAPHITE/FIBERGLASS/EPOXY HONEYCOMB SANDWICH SEE DETAIL VIII ARAMID HONEYCOMB AS GIVEN IN BMS 8-124, CLASS 4, TYPE V, GRADE 3.0	P
9	SKIN PANEL SKIN CORE		GRAPHITE/FIBERGLASS/EPOXY HONEYCOMB SANDWICH SEE DETAIL IX ARAMID HONETCOMB AS GIVEN IN BMS 8-124, CLASS 4, TYPE V, GRADE 3.0	P
10	SKIN PANEL SKIN CORE		GRAPHITE/FIBERGLASS/EPOXY HONEYCOMB SANDWICH SEE DETAIL X ARAMID HONEYCOMB AS GIVEN IN BMS 8-124, CLASS 4, TYPE V, GRADE 3.0	P

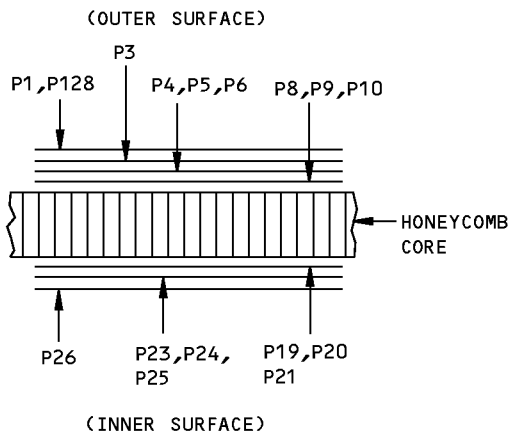
LIST OF MATERIALS FOR DETAIL I AND DETAIL VI

**Section 43 Wing-to-Body Fairing Skin Identification
Figure 1 (Sheet 3 of 12)**

**757-200
STRUCTURAL REPAIR MANUAL**



LEFT SIDE SHOWN
RIGHT SIDE SIMILAR
VIEW ON PANELS **C**



SECTION THRU HONEYCOMB PANEL

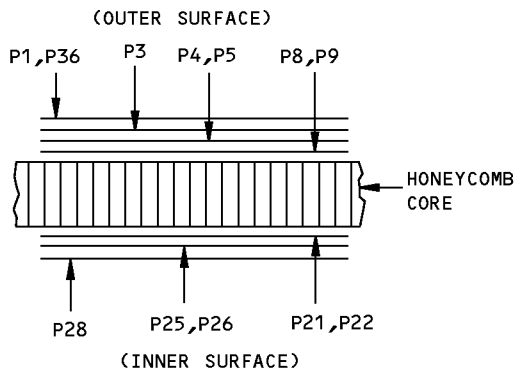
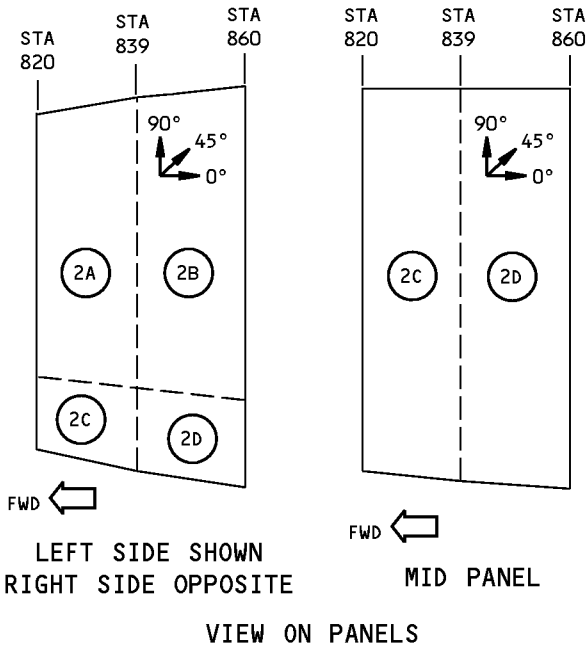
ITEM NO.	PLY NO.	MATERIAL	PLY ORIENTATION A
1	1A	P3,P26	D 0° OR 90°
		P4,P23	E 0°
		P8,P19	F 0° OR 90°
		P128	K J 0° OR 90°
	1B	P3,P26	D 0° OR 90°
		P5,P24	G 0°
		P9,P20	F 0° OR 90°
		P128	K J 0° OR 90°
	1C	P3,P26	D 0° OR 90°
		P6,P25	G 0°
		P10,P21	F 0° OR 90°
		P128	K J 0° OR 90°
	1D	P1	M H 0° OR 90°
		P1	N L 0° OR 90°
		P3,P26	D 0° OR 90°
		P4,P23	E 0°
	1E	P8,P19	F 0° OR 90°
		P1	M H 0° OR 90°
		P1	N L 0° OR 90°
		P3,P26	D 0° OR 90°
	1F	P5,P24	G 0°
		P9,P20	F 0° OR 90°
		P1	M H 0° OR 90°
		P1	N L 0° OR 90°
	P3,P26	D 0° OR 90°	
	P6,P25	G 0°	
	P10,P21	F 0° OR 90°	

PLY TABLE **B**

DETAIL II **O**

**Section 43 Wing-to-Body Fairing Skin Identification
Figure 1 (Sheet 4 of 12)**

**757-200
STRUCTURAL REPAIR MANUAL**



SECTION THRU HONEYCOMB PANEL

ITEM NO.	PLY NO.	MATERIAL	PLY ORIENTATION ^A	
2	2A	P3,P28	D	0° OR 90°
		P4,P25	G	0°
		P8,P21	F	0° OR 90°
		P36	K J	0° OR 90°
	2B	P3,P28	D	0° OR 90°
		P5,P26	G	0°
		P9,P22	F	0° OR 90°
		P36	K J	0° OR 90°
	2C	P1	M H	0° OR 90°
		P1	N L	0° OR 90°
		P3,P28	D	0° OR 90°
		P4,P25	G	0°
2D	P8,P21	F	0° OR 90°	
	P1	M H	0° OR 90°	
	P1	N L	0° OR 90°	
	P3,P28	D	0° OR 90°	
2D	P5,P26	G	0°	
	P9,P22	F	0° OR 90°	

PLY TABLE ^B

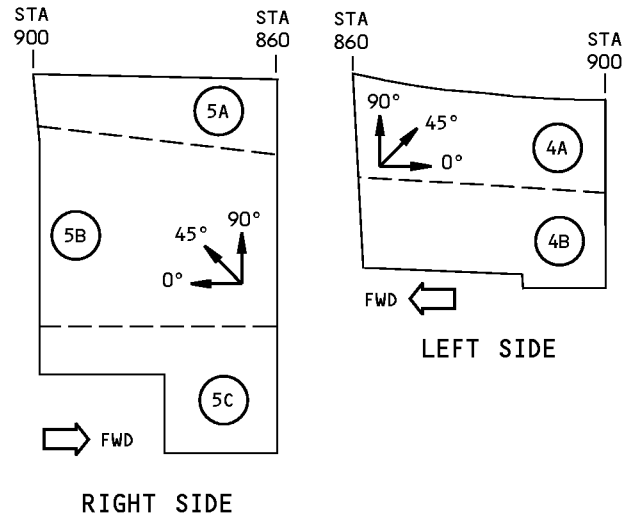
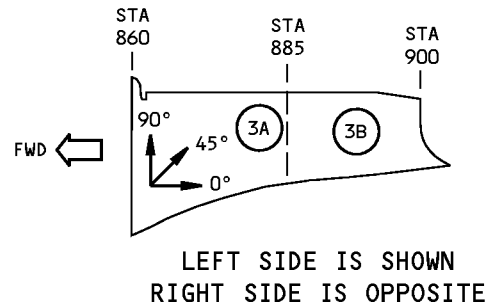
DETAIL III ⁰

**Section 43 Wing-to-Body Fairing Skin Identification
Figure 1 (Sheet 5 of 12)**

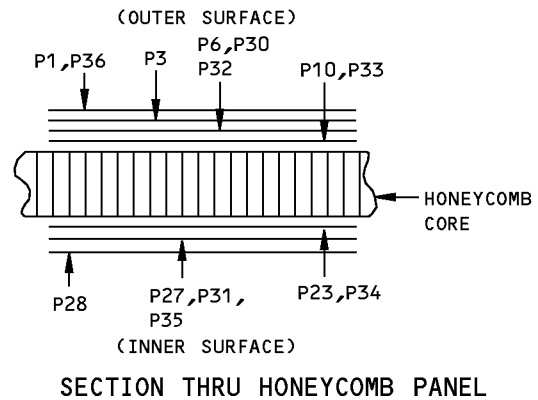
**757-200
STRUCTURAL REPAIR MANUAL**

ITEM NO.	PLY NO.	MATERIAL	PLY ORIENTATION [A]		
3	3A	P3,P28	D	0° OR 90°	
		P32,P35	E	90°	
		P33,P34	F	0° OR 90°	
		P36	K J	0° OR 90°	
	3B	P3,P28	D	0° OR 90°	
		P32,P35	G	90°	
		P33,P34	F	0° OR 90°	
		P36	K J	0° OR 90°	
4	4A	P3,P28	D	0° OR 90°	
		P6,P27	F	0° OR 90°	
		P10,P23	F	0° OR 90°	
		P30	K J	0° OR 90°	
	4B	P1	M H N L	0° OR 90°	
		P3,P28	D	0° OR 90°	
		P6,P27	F	0° OR 90°	
		P10,P23	F	0° OR 90°	
		P30	K J	0° OR 90°	
		5A	P23,P28	D	0° OR 90°
			P6,P27	G	0°
			P10,P23	F	0° OR 90°
P32	K J		0° OR 90°		
5B	P1	M H N L	0° OR 90°		
	P3,P28	D	0° OR 90°		
	P6,P27	G	0°		
	P10,P23	F	0° OR 90°		
	5C	P32	K J	0° OR 90°	
P1		M H N L	0° OR 90°		
P3,P28		D	0° OR 90°		
P30,P31		F	0° OR 90°		
P10,P23		F	0° OR 90°		

PLY TABLE [B]



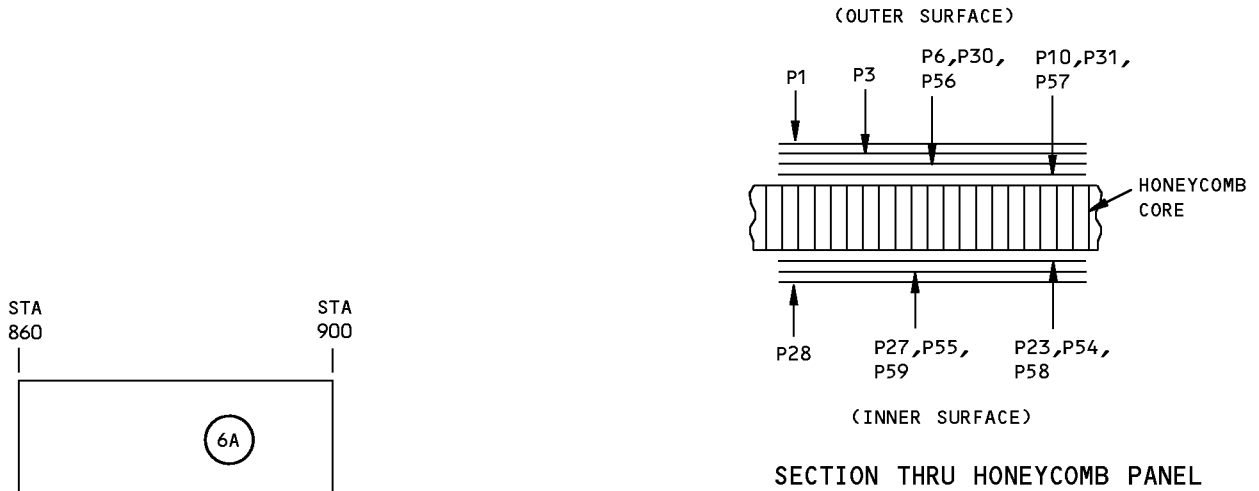
VIEW ON PANELS [C]



DETAIL IV [D]

**Section 43 Wing-to-Body Fairing Skin Identification
Figure 1 (Sheet 6 of 12)**

**757-200
STRUCTURAL REPAIR MANUAL**



SECTION THRU HONEYCOMB PANEL

VIEW ON PANEL [C]

ITEM NO.	PLY NO.	MATERIAL	PLY ORIENTATION [A]				
6	6A	P1 P1	<table border="1"><tr><td>M</td><td>H</td></tr><tr><td>N</td><td>L</td></tr></table> 0° OR 90°	M	H	N	L
		M	H				
		N	L				
		P3, P28	<table border="1"><tr><td>D</td></tr></table> 0° OR 90°	D			
	D						
	P6, P27	<table border="1"><tr><td>F</td></tr></table> 0° OR 90°	F				
	F						
	P10, P23	<table border="1"><tr><td>F</td></tr></table> 0° OR 90°	F				
	F						
	6B	P1 P1	<table border="1"><tr><td>M</td><td>H</td></tr><tr><td>N</td><td>L</td></tr></table> 0° OR 90°	M	H	N	L
		M	H				
		N	L				
P3, P28		<table border="1"><tr><td>D</td></tr></table> 0° OR 90°	D				
D							
P30, P55	<table border="1"><tr><td>F</td></tr></table> 0° OR 90°	F					
F							
P31, P54	<table border="1"><tr><td>F</td></tr></table> 0° OR 90°	F					
F							
6C	P1 P1	<table border="1"><tr><td>M</td><td>H</td></tr><tr><td>N</td><td>L</td></tr></table> 0° OR 90°	M	H	N	L	
	M	H					
	N	L					
	P3, P28	<table border="1"><tr><td>D</td></tr></table> 0° OR 90°	D				
D							
P56, P59	<table border="1"><tr><td>F</td></tr></table> 0° OR 90°	F					
F							
P57, P58	<table border="1"><tr><td>F</td></tr></table> 0° OR 90°	F					
F							

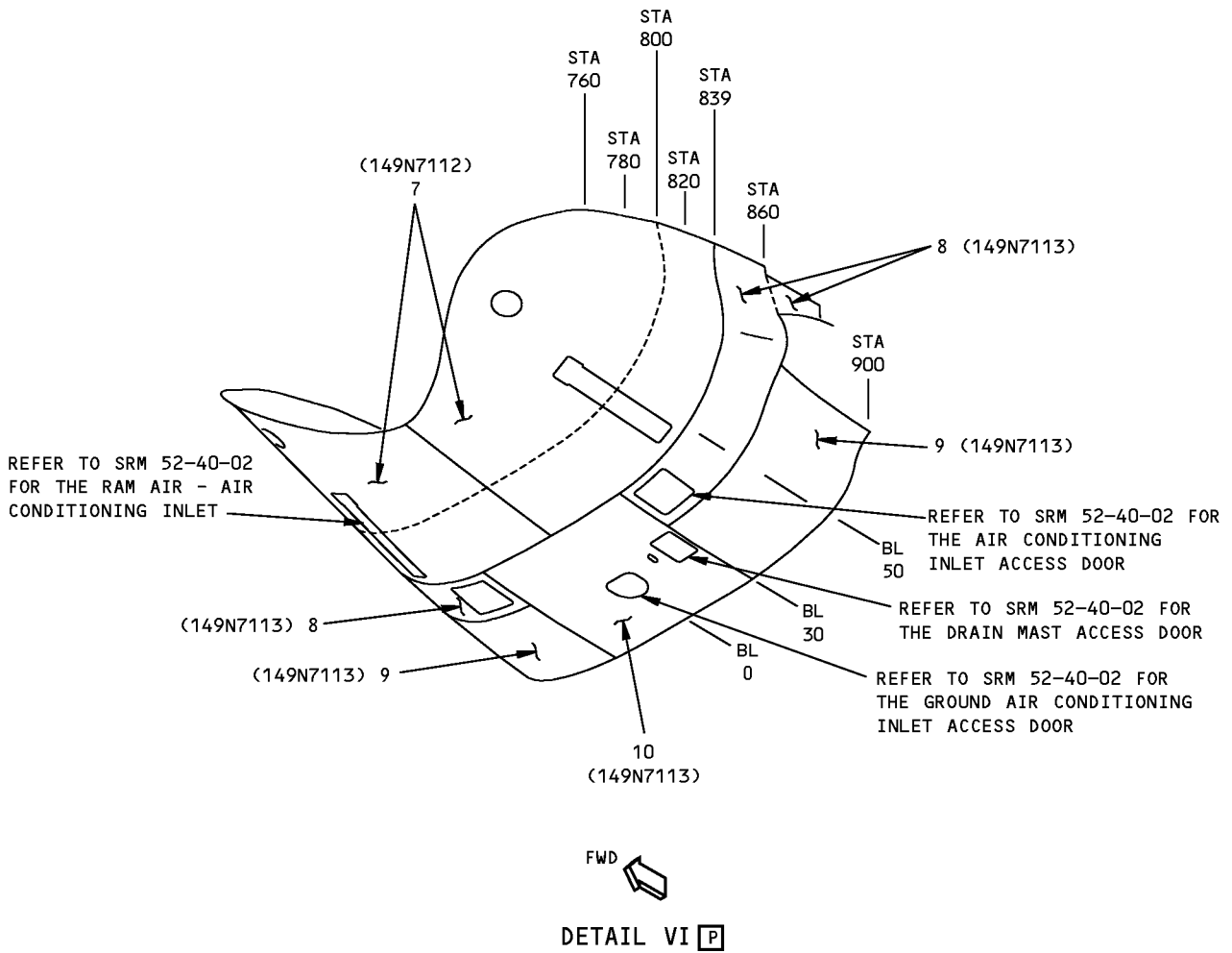
PLY TABLE [B]

DETAIL V [0]

**Section 43 Wing-to-Body Fairing Skin Identification
Figure 1 (Sheet 7 of 12)**

**757-200
STRUCTURAL REPAIR MANUAL**

REFERENCE DRAWING
149N7100



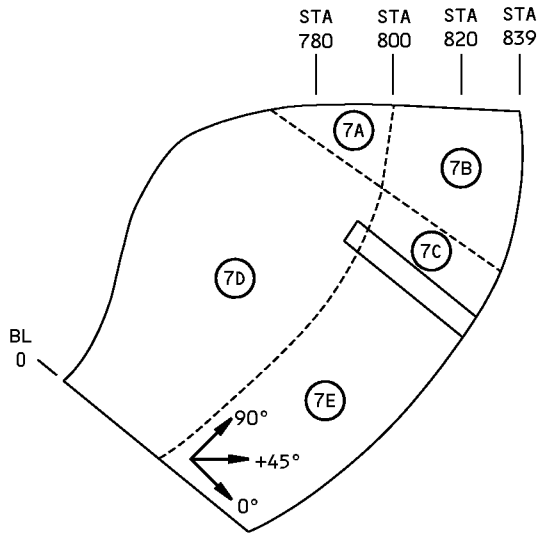
**Section 43 Wing-to-Body Fairing Skin Identification
Figure 1 (Sheet 8 of 12)**

IDENTIFICATION 1
Page 8
May 20/2007

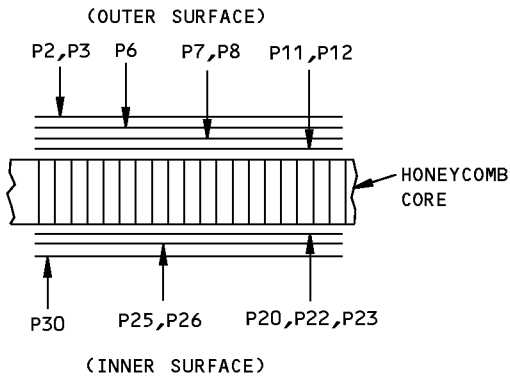
53-30-70

D634N201

**757-200
STRUCTURAL REPAIR MANUAL**



LEFT SIDE IS SHOWN,
RIGHT SIDE IS SIMILAR
VIEW ON PANELS **C**



SECTION THRU HONEYCOMB PANEL

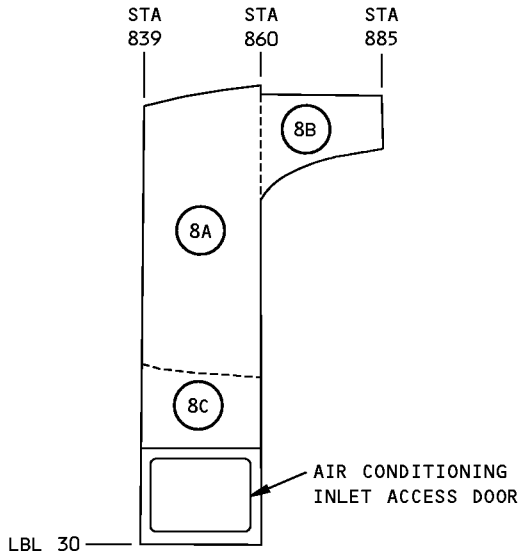
DETAIL VII **P**

ITEM NO.	PLY NO.	MATERIAL	PLY ORIENTATION A	
7	7A	P3,P30	J	0° OR 90°
		P7,P12 P22,P25	F	0° OR 90°
	7B	P3,P30	J	0° OR 90°
		P6,P11 P20,P26	F	0° OR 90°
	7C	P3,P30	J	0° OR 90°
		P6,P11 P20,P26	F	0° OR 90°
		P2	R	—
	7D	P3,P30	J	0° OR 90°
		P7,P12 P22,P25	F	0° OR 90°
		P2	R	—
	7E	P3,P30	J	0° OR 90°
		P8,P13	F	0° OR 90°
		P2	R	—

PLY TABLE **B**

**Section 43 Wing-to-Body Fairing Skin Identification
Figure 1 (Sheet 9 of 12)**

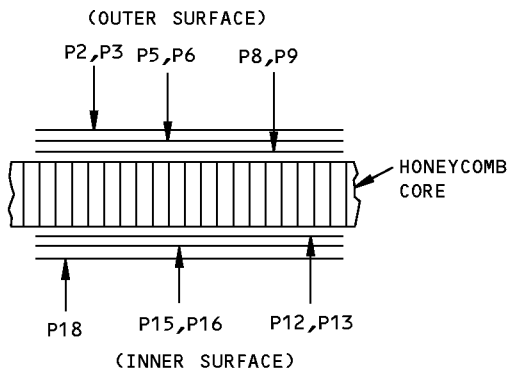
**757-200
STRUCTURAL REPAIR MANUAL**



LEFT SIDE IS SHOWN
RIGHT SIDE IS OPPOSITE
VIEW ON PANELS [C]

ITEM NO.	PLY NO.	MATERIAL	PLY ORIENTATION [A]
8	8A	P3,P18	[Q] 0° OR 90°
		P5,P8 P12,P15	[F] 0° OR 90°
	8B	P3,P18	[Q] 0° OR 90°
		P6,P9 P13,P16	[F] 0° OR 90°
	8C	P2	[R] —
		P3,P18	[Q] 0° OR 90°
P5,P8 P12,P15		[F] 0° OR 90°	

PLY TABLE [B]



SECTION THRU HONEYCOMB PANEL

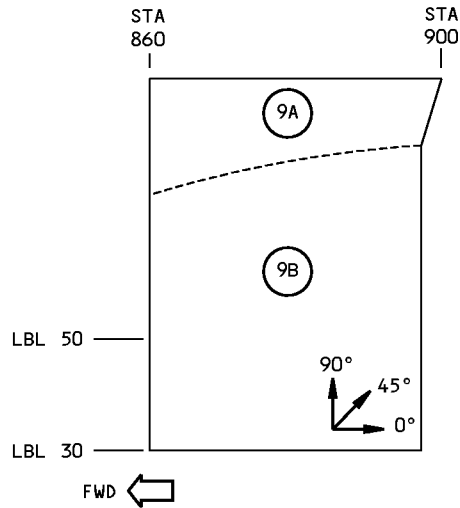
DETAIL VIII [P]

**Section 43 Wing-to-Body Fairing Skin Identification
Figure 1 (Sheet 10 of 12)**

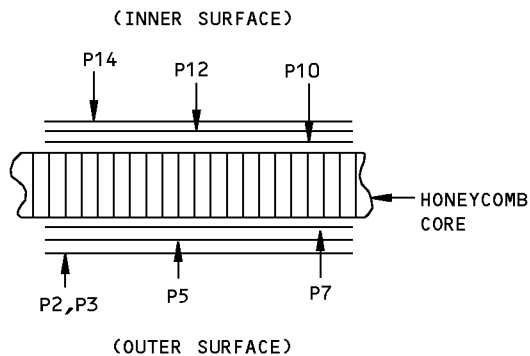
**757-200
STRUCTURAL REPAIR MANUAL**

ITEM NO.	PLY NO.	MATERIAL	PLY ORIENTATION A	
9	9A	P3,P14	Q	0° OR 90°
		P5,P7 P10,P12	F	0° OR 90°
	9B	P2	R	—
		P3,P14	Q	0° OR 90°
		P5,P7 P10,P12	F	0° OR 90°

PLY TABLE B



VIEW ON PANELS C

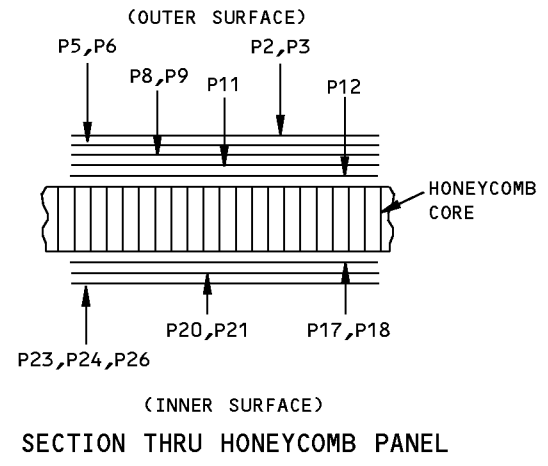
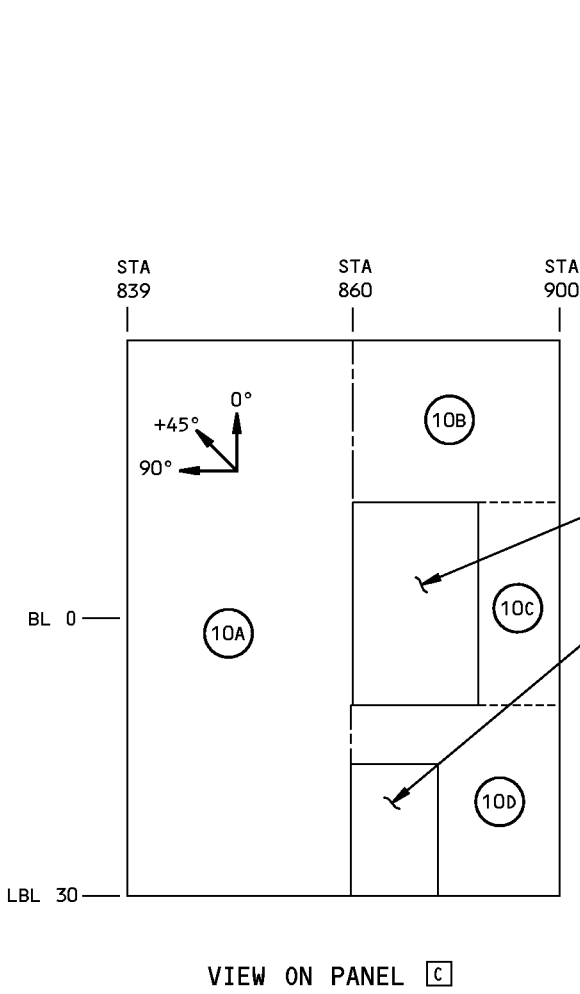


SECTION THRU HONEYCOMB PANEL

DETAIL IX P

**Section 43 Wing-to-Body Fairing Skin Identification
Figure 1 (Sheet 11 of 12)**

**757-200
STRUCTURAL REPAIR MANUAL**



ITEM NO.	PLY NO.	MATERIAL	PLY ORIENTATION A	
4	10A	P3,P26	Q	0° OR 90°
		P8,P11 P17,P20	F	0° OR 90°
		P2	R	—
	10B	P3,P26	Q	0° OR 90°
		P5,P24	E	90°
		P9,P12 P18,P21	F	0° OR 90°
		P2	R	—
	10C	P3,P26	Q	0° OR 90°
		P6,P23	E	
		P9,P12 P18,P21	F	0° OR 90°
	10D	P3,P26	Q	0° OR 90°
		P9,P12 P18,P21	F	0° OR 90°
P2		R	—	

PLY TABLE **B**

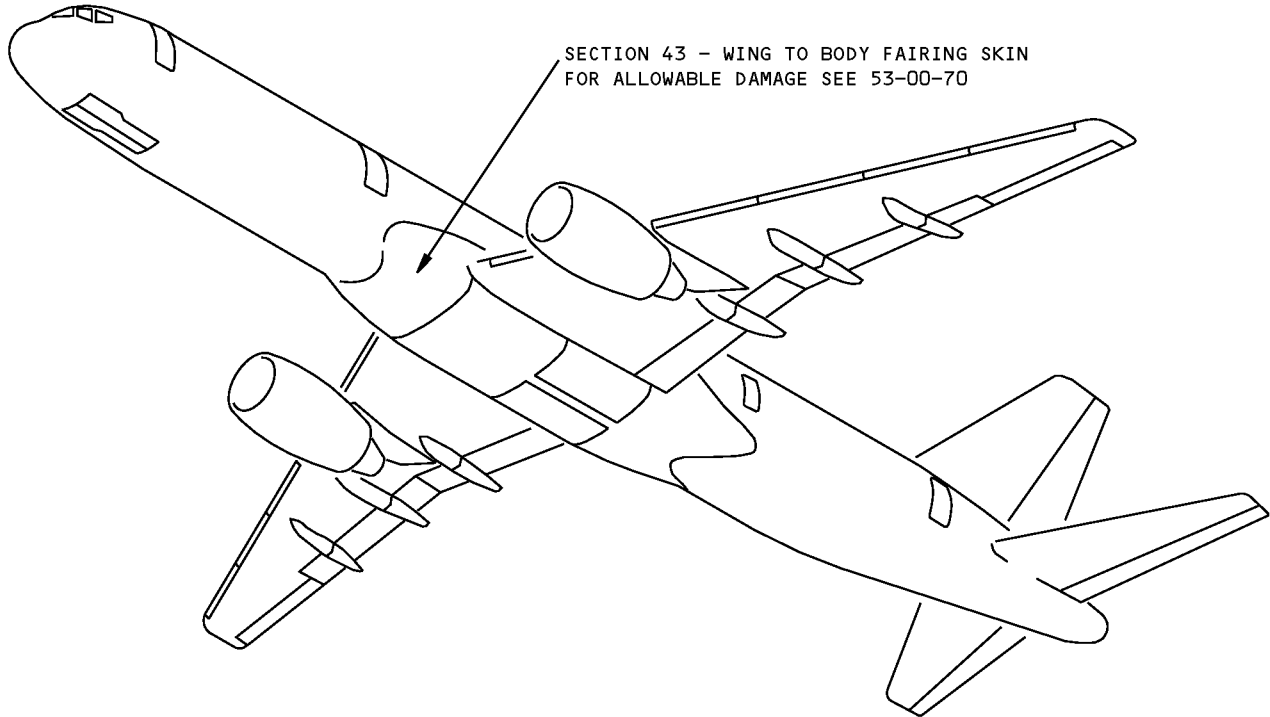
DETAIL X **P**

**Section 43 Wing-to-Body Fairing Skin Identification
Figure 1 (Sheet 12 of 12)**



757-200
STRUCTURAL REPAIR MANUAL

ALLOWABLE DAMAGE GENERAL - SECTION 43 - WING-TO-BODY FAIRING SKINS



Section 43 Wing-to-Body Fairing Skin Allowable Damage
Figure 101

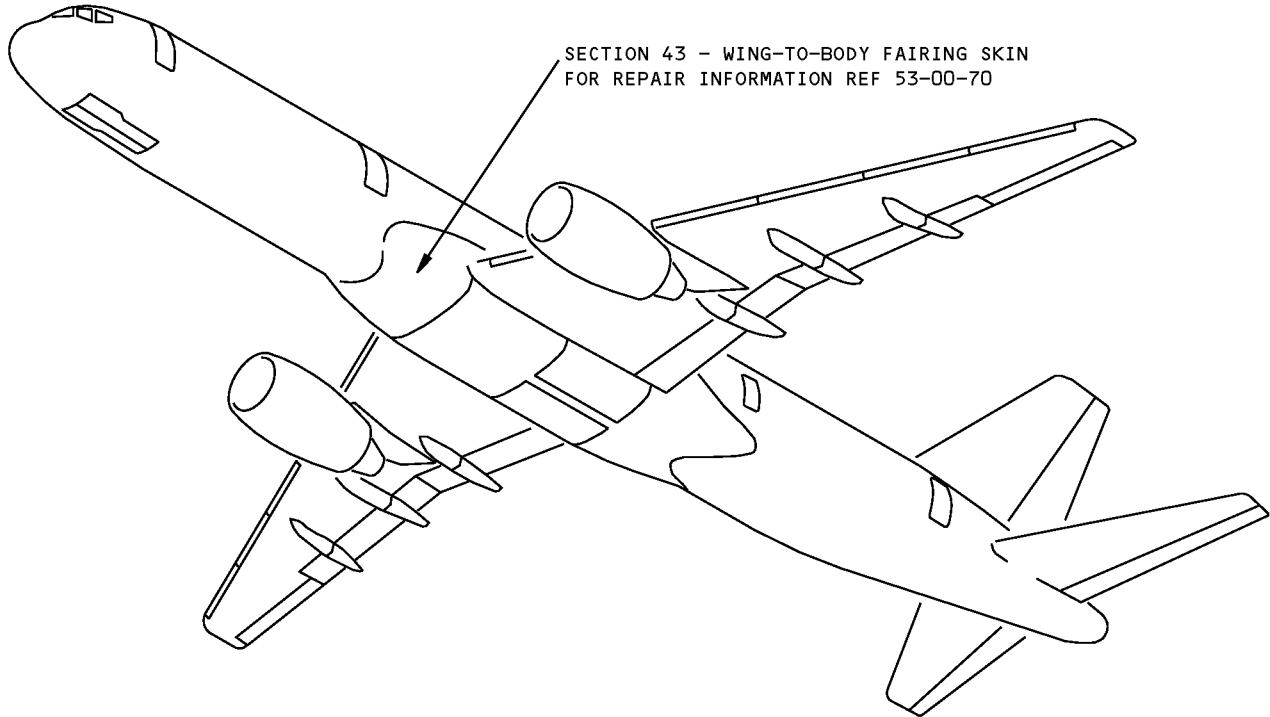
D634N201

ALLOWABLE DAMAGE GENERAL
53-30-70
Page 101
Jan 20/2005



757-200
STRUCTURAL REPAIR MANUAL

REPAIR GENERAL - SECTION 43 - WING-TO-BODY FAIRING SKINS



Section 43 Wing-to-Body Fairing Skin Repairs
Figure 201

D634N201

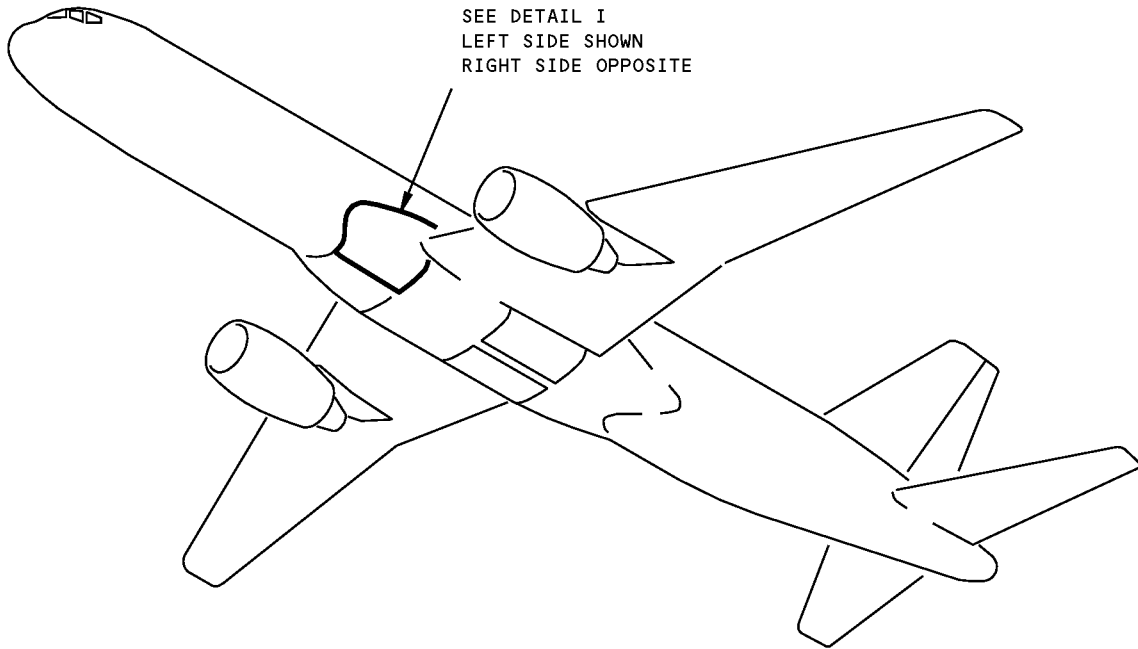
53-30-70

REPAIR GENERAL
Page 201
Jan 20/2005



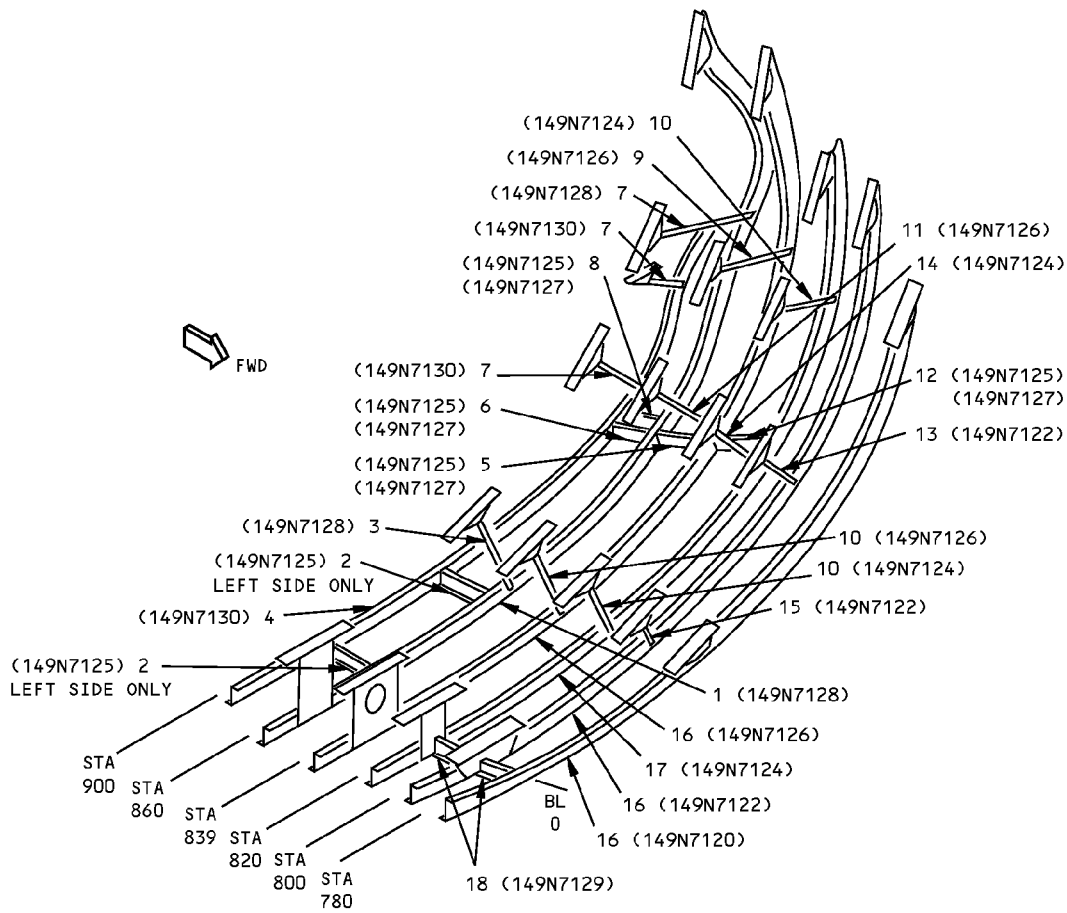
757-200
STRUCTURAL REPAIR MANUAL

IDENTIFICATION 1 - SECTION 43 - WING-TO-BODY FAIRING STRUCTURE



Section 43 Wing-to-Body Fairing Structure Identification
Figure 1 (Sheet 1 of 3)

**757-200
STRUCTURAL REPAIR MANUAL**



LEFT SIDE SHOWN
RIGHT SIDE OPPOSITE EXCEPT AS NOTED

DETAIL I

LIST OF
MATL

**Section 43 Wing-to-Body Fairing Structure Identification
Figure 1 (Sheet 2 of 3)**



**757-200
STRUCTURAL REPAIR MANUAL**

ITEM	DESCRIPTION	GAGE	MATERIAL	EFFECTIVITY
1	FRAME OUTBOARD CHORD	0.063	CLAD 7075-T6 BAC1505-100274 7075-T73	
2	INTERCOSTAL CHORD WEB	0.063	AND10136-1503 7075-T73 CLAD 7075-T6	
3	STRUT		AND10137-1010 7075-T73511	
4	FRAME OUTBOARD CHORD	0.080	CLAD 7075-T6 BAC1505-100403 7075-T6	
5	INTERCOSTAL CHORD WEB	0.040	BAC1505-100962 7075-T73 CLAD 7075-T6	
6	INTERCOSTAL CHORD WEB	0.063	BAC1505-101029 7075-T73 CLAD 7075-T6	
7	STRUT		BAC1509-100305 7075-T73511	
8	INTERCOSTAL CHORD WEB	0.063	BAC1503-100142 7075-T42 CLAD 7075-T6	
9	STRUT		AND10137-0605 7075-T73511	
10	STRUT		AND10137-0604 7075-T73511	
11	STRUT		AND10137-0707 7075-T73511	
12	INTERCOSTAL CHORD WEB	0.040	BAC1505-101030 7075-T73 CLAD 7075-T6	
13	STRUT		AND10137-0602 7075-T73511	
14	STRUT		AND10137-0603 7075-T73511	
15	STRUT		AND10137-0601 7075-T73511	
16	FRAME	0.063	CLAD 7075-T6	
17	FRAME OUTBOARD CHORD	0.050	CLAD 7075-T6 BAC1505-100351 7075-T73	
18	INTERCOSTAL WEB TEE	0.040	CLAD 7075-T6 BAC1505-100351 7075-T73	

LIST OF MATERIALS FOR DETAIL I

**Section 43 Wing-to-Body Fairing Structure Identification
Figure 1 (Sheet 3 of 3)**

IDENTIFICATION 1
Page 3
Jan 20/2005

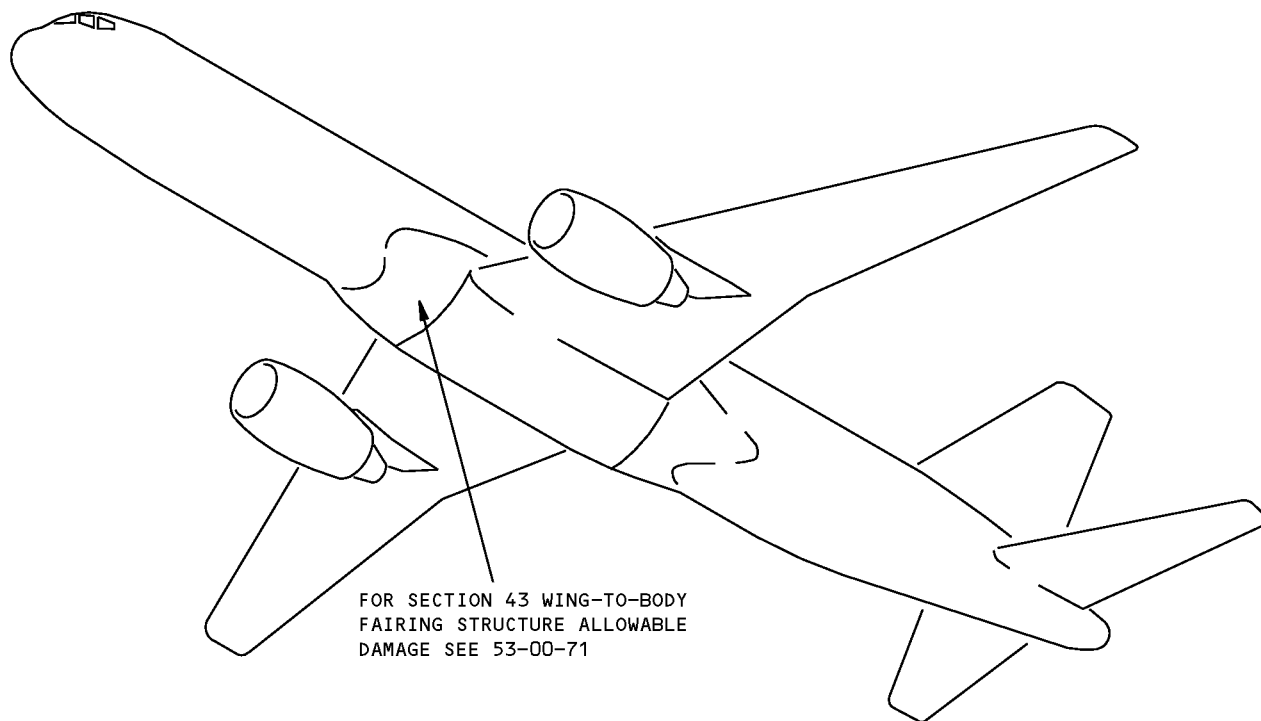
53-30-71

D634N201



757-200
STRUCTURAL REPAIR MANUAL

ALLOWABLE DAMAGE GENERAL - SECTION 43 - WING-TO-BODY FAIRING STRUCTURE



Section 43 Wing-to-Body Fairing Structure Allowable Damage
Figure 101

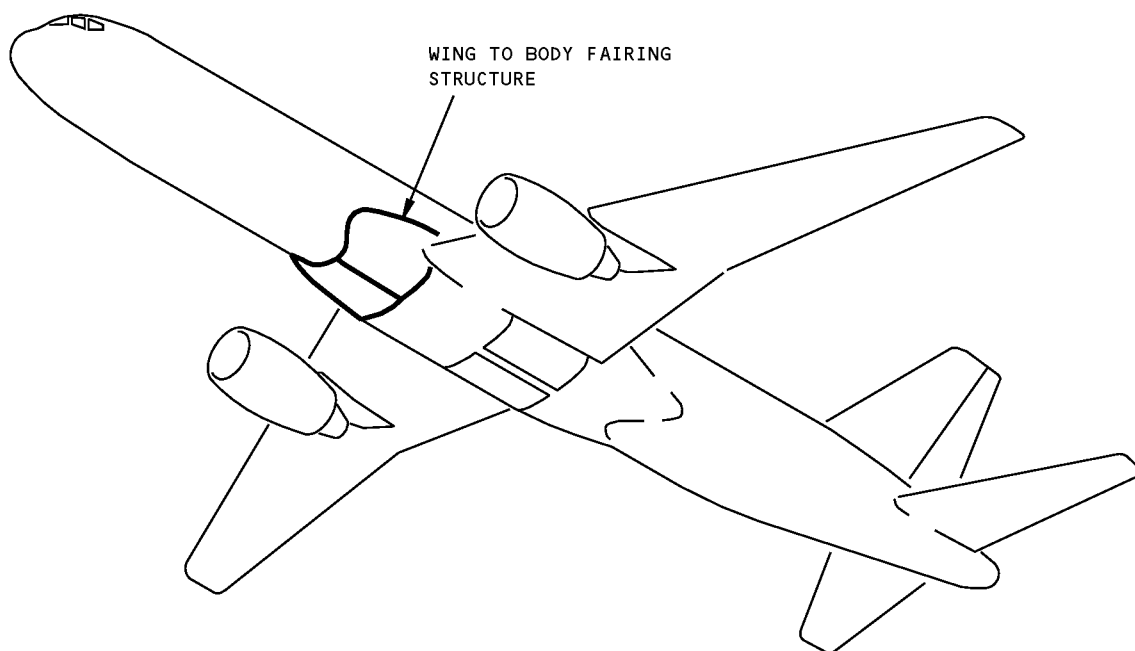
D634N201

ALLOWABLE DAMAGE GENERAL
Page 101
53-30-71
Jan 20/2005



757-200
STRUCTURAL REPAIR MANUAL

REPAIR GENERAL - SECTION 43 - WING-TO-BODY FAIRING STRUCTURE



NOTES

- SEE 51-70-11 FOR FORMED SECTION REPAIR
- SEE 51-70-12 FOR EXTRUDED SECTION REPAIR
- SEE 51-70-13 FOR WEB REPAIRS

Section 43 Wing-to-Body Fairing Structure Repair
Figure 201

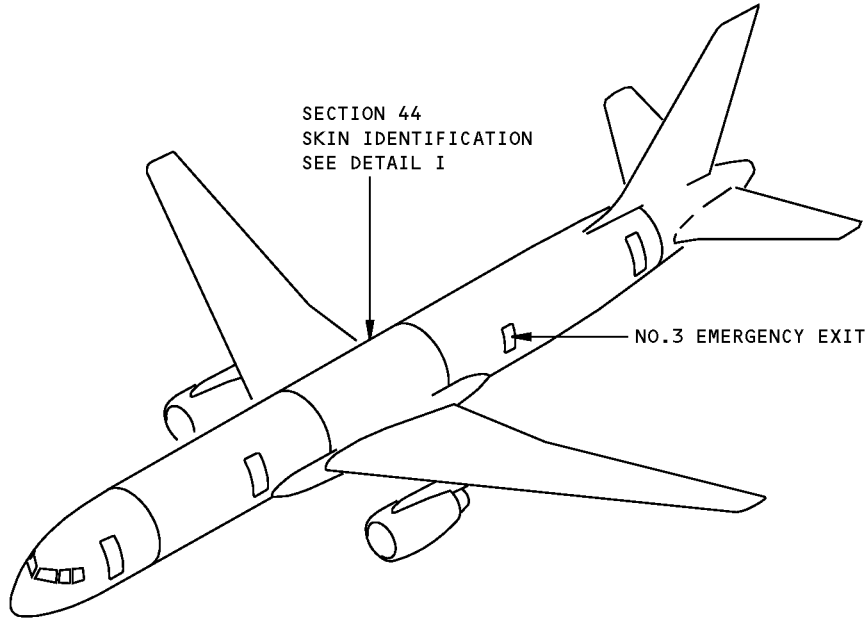
D634N201

53-30-71

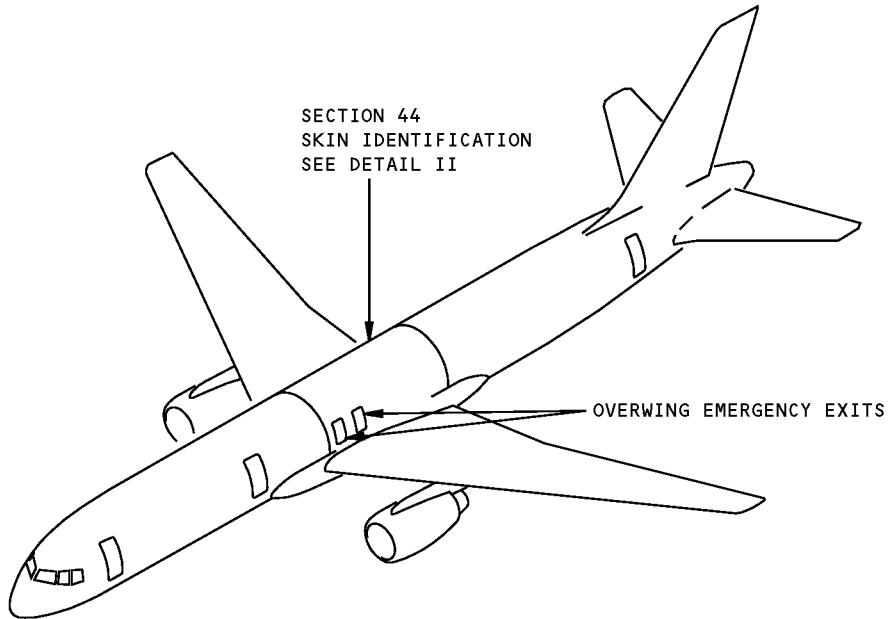
REPAIR GENERAL
Page 201
Jan 20/2005

757-200
STRUCTURAL REPAIR MANUAL

IDENTIFICATION 1 - SECTION 44 - SKINS



**AIRPLANES WITH NO. 3 EMERGENCY EXIT
BASIC CONFIGURATION**

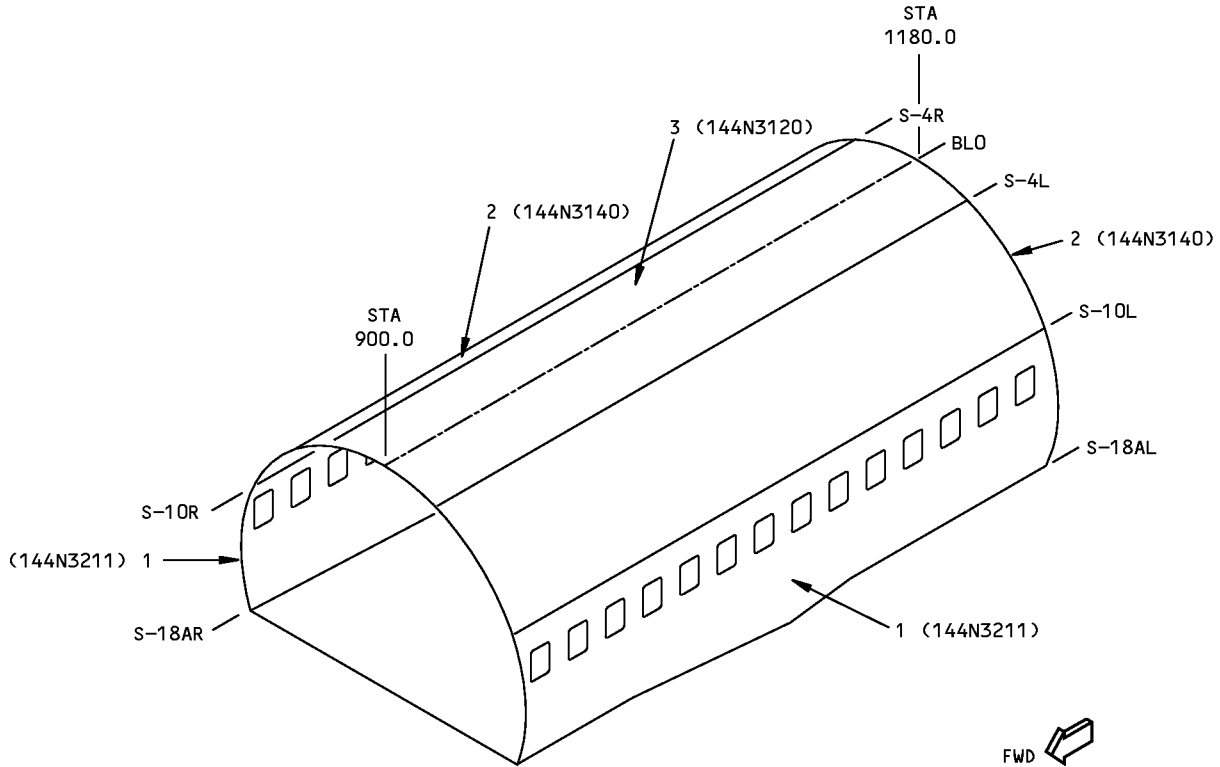


**AIRPLANES WITH OVERWING EMERGENCY EXITS
BASIC CONFIGURATION**

**Section 44 Skin Identification
Figure 1 (Sheet 1 of 3)**

**757-200
STRUCTURAL REPAIR MANUAL**

REFERENCE DRAWINGS
144N3100
144N3200



**AIRPLANES WITHOUT OVERWING EMERGENCY EXITS
DETAIL I**

ITEM	DESCRIPTION	GAGE ^A	MATERIAL	EFFECTIVITY
1	SKIN, STRINGER 10 TO WING	0.375	CLAD 2024-T351	
2	SKIN, STRINGER 4 TO 10	0.175	CLAD 2024-T3	
3	SKIN, STRINGER 4L TO 4R	0.200	CLAD 2024-T3	

LIST OF MATERIALS FOR DETAIL I

NOTES

^A GAGES VARY; GAGE SHOWN IS MAXIMUM.

9281 S0006802760_V2

**Section 44 Skin Identification
Figure 1 (Sheet 2 of 3)**

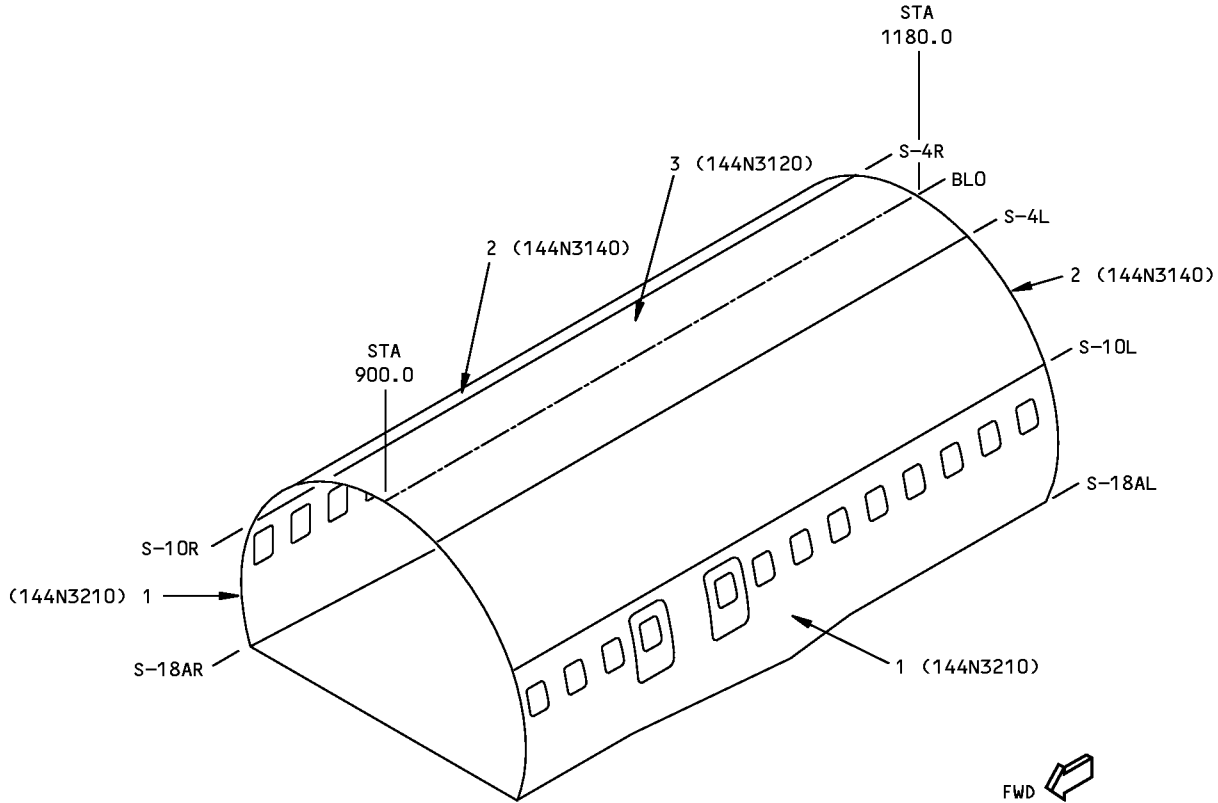
D634N201

53-40-01

IDENTIFICATION 1
Page 2
May 20/2008

**757-200
STRUCTURAL REPAIR MANUAL**

REFERENCE DRAWING
144N3201



AIRPLANES WITH OVERWING EMERGENCY EXITS
DETAIL II

ITEM	DESCRIPTION	GAGE ^A	MATERIAL	EFFECTIVITY
1	SKIN, STRINGER 10 TO WING	0.500	CLAD 2024-T351	
2	SKIN, STRINGER 4 TO 10	0.175	CLAD 2024-T3	
3	SKIN, STRINGER 4L TO 4R	0.200	CLAD 2024-T3	

LIST OF MATERIALS FOR DETAIL I

NOTES

^A GAGES VARY; GAGE SHOWN IS MAXIMUM.

132461 S0006802764_V2

**Section 44 Skin Identification
Figure 1 (Sheet 3 of 3)**

D634N201

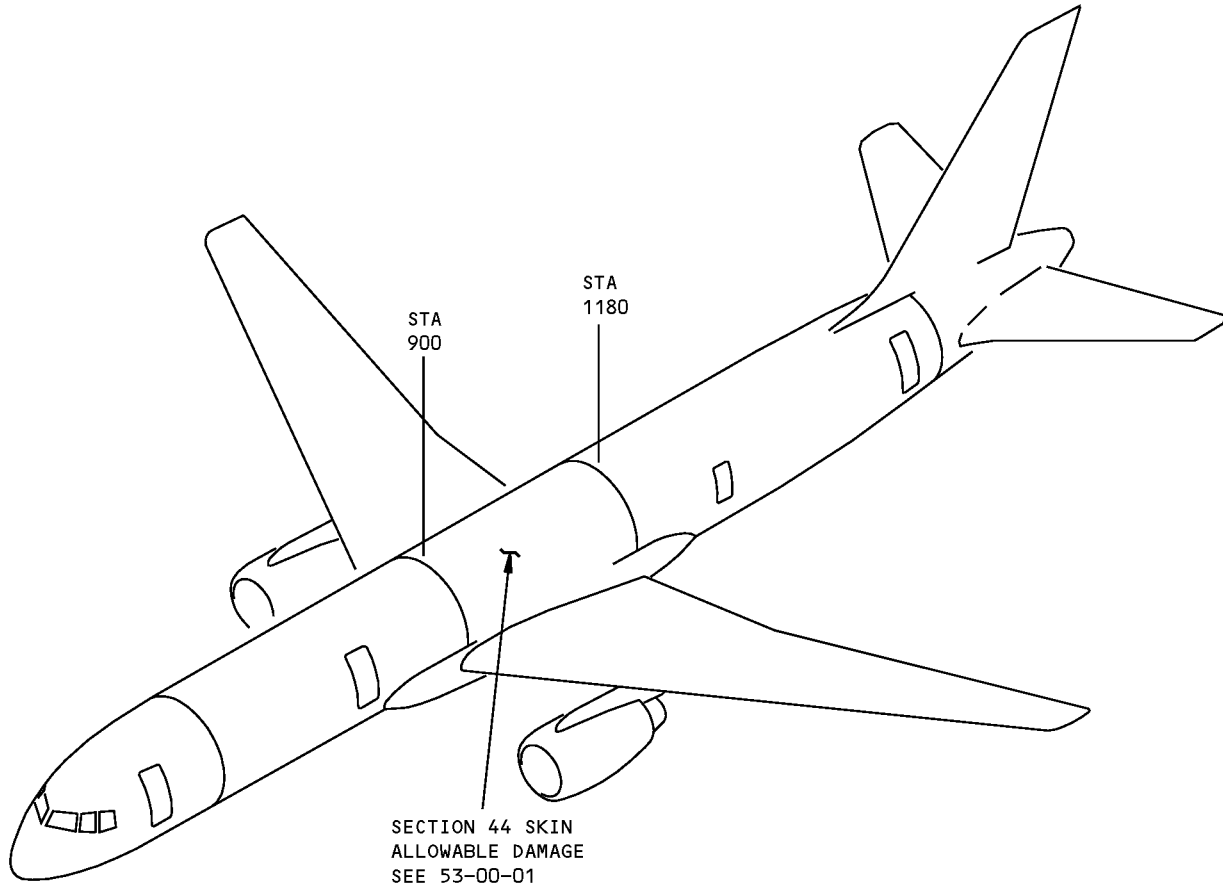
53-40-01

IDENTIFICATION 1
Page 3
May 20/2008



757-200
STRUCTURAL REPAIR MANUAL

ALLOWABLE DAMAGE GENERAL - SECTION 44 - SKINS



Section 44 Skin Allowable Damage
Figure 101

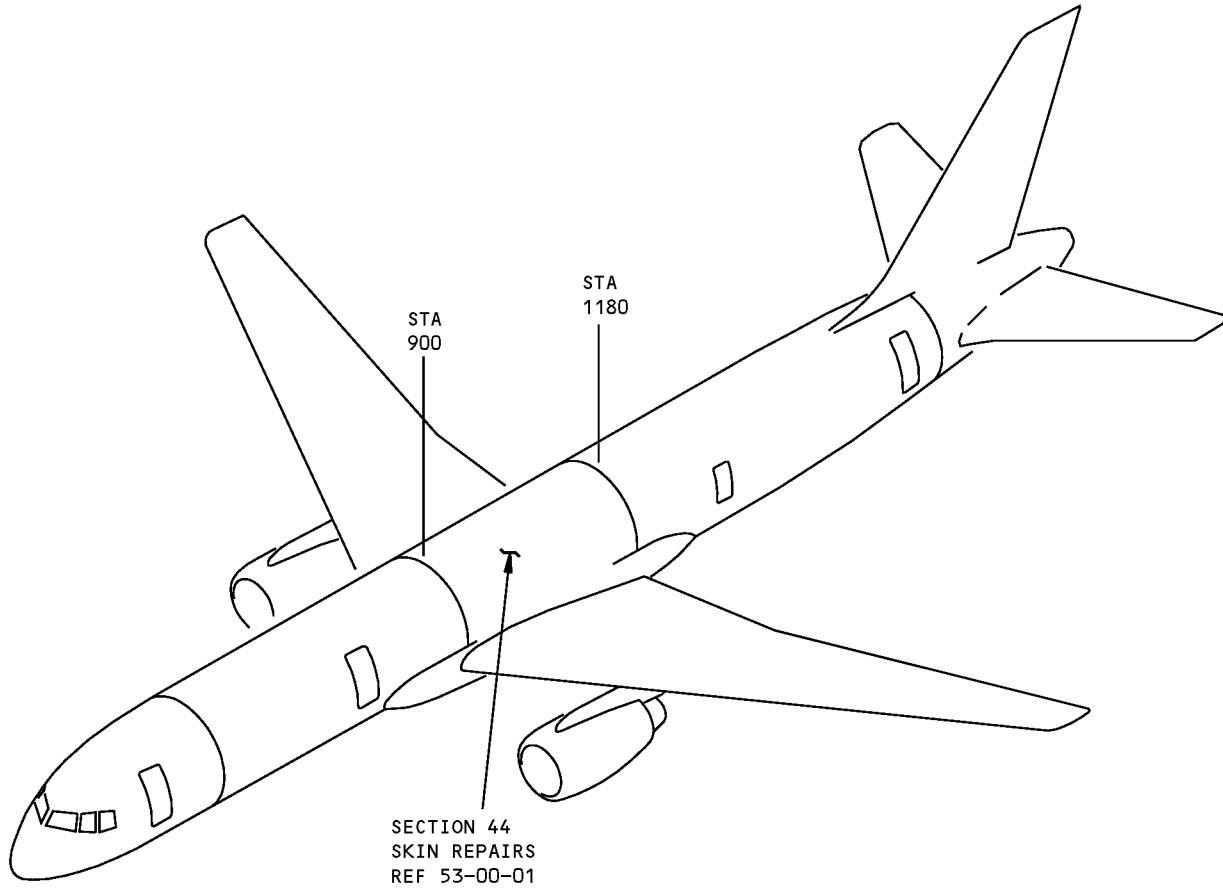
D634N201

ALLOWABLE DAMAGE GENERAL
Page 101
53-40-01
Jan 20/2005



757-200
STRUCTURAL REPAIR MANUAL

REPAIR GENERAL - SECTION 44 - SKINS



Section 44 Skin Repair
Figure 201

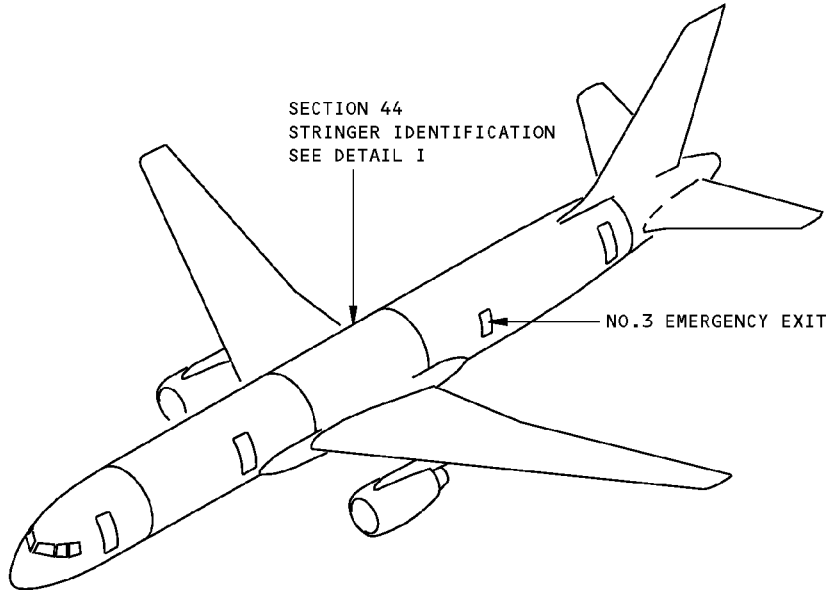
D634N201

53-40-01

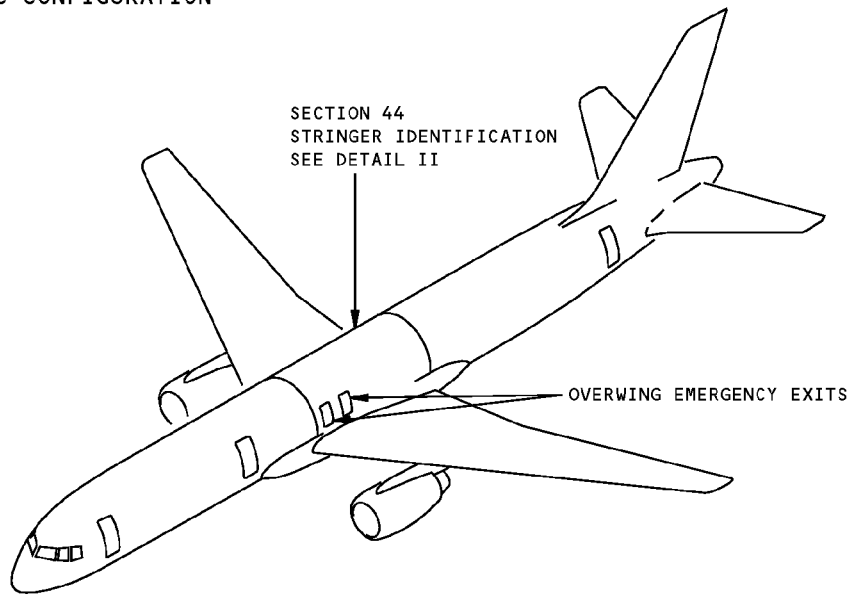
REPAIR GENERAL
Page 201
Jan 20/2005

757-200
STRUCTURAL REPAIR MANUAL

IDENTIFICATION 1 - SECTION 44 - STRINGERS



**AIRPLANES WITH NO. 3 EMERGENCY EXIT
BASIC CONFIGURATION**



**AIRPLANES WITH OVERWING EMERGENCY EXITS
BASIC CONFIGURATION**

NOTES

A GAGES VARY ALONG THE LENGTH, GAGES GIVEN ARE MAXIMUMS

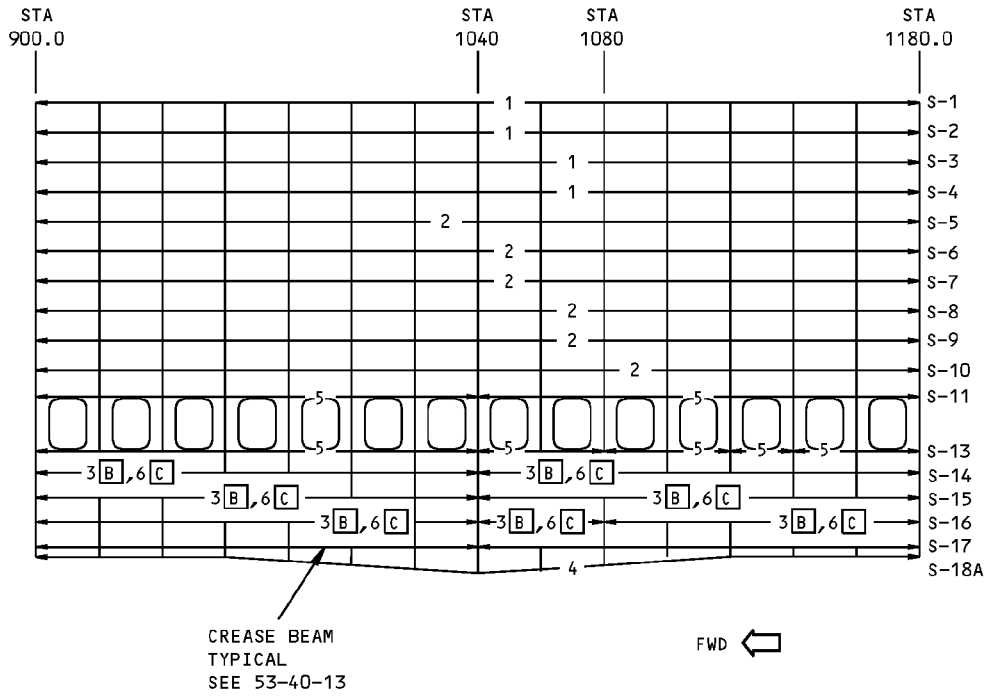
C FOR CUM LINE NUMBERS:
28 AND ON

B FOR CUM LINE NUMBERS:
1 THRU 27

**Section 44 Stringer Identification
Figure 1 (Sheet 1 of 3)**

**757-200
STRUCTURAL REPAIR MANUAL**

REF DWG
144N3100



DETAIL I

ITEM	DESCRIPTION	GAGE	MATERIAL	STRINGER TYPE	REF DWG	EFFECTIVITY
1	STRINGER A	0.125	7075-T6		144N3110	
2	STRINGER A	0.112	7075-T6		144N3110	
3	STRINGER		BAC1509-100500 OPTIONAL BAC1509-100464 7075-T6511		144N3240	B
4	STRINGER A	1.150	7075-T6511		144N8150	
5	STRINGER		BAC1517-2154 7075-T6511		144N3230	
6	STRINGER		BAC1509-100507 7075-T6511		144N3242	C

LIST OF MATERIALS FOR DETAIL I

**Section 44 Stringer Identification
Figure 1 (Sheet 2 of 3)**

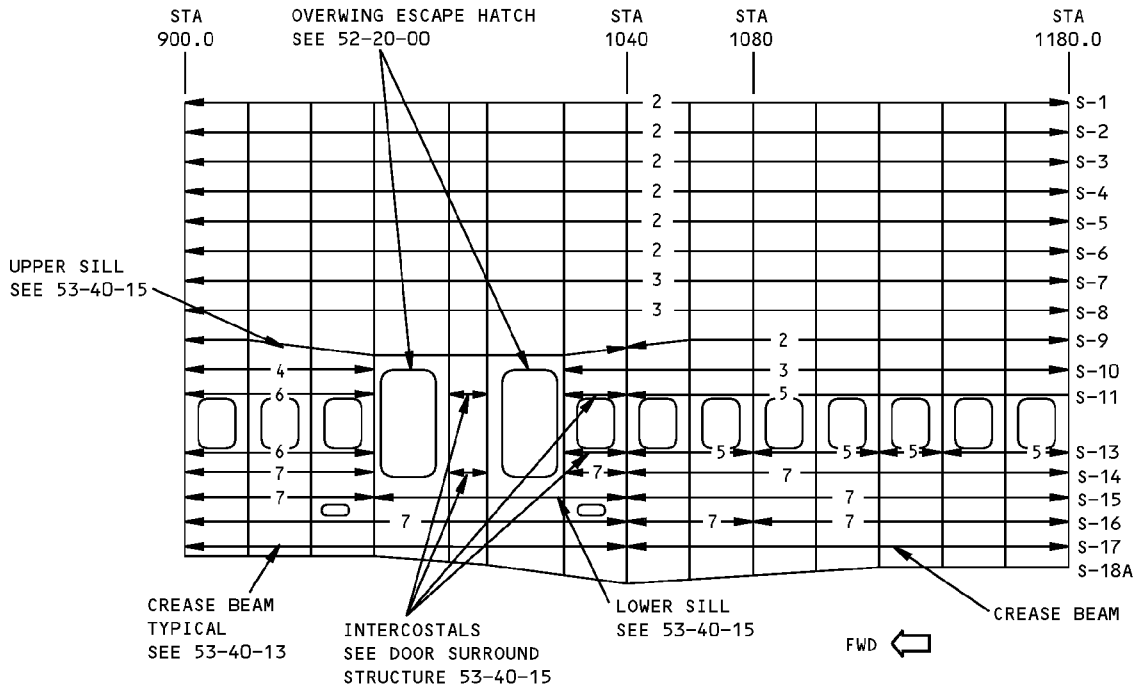
IDENTIFICATION 1
Page 2
Jan 20/2005

53-40-03

D634N201

**757-200
STRUCTURAL REPAIR MANUAL**

REF DWG
144N3201



**AIRPLANES WITH OVERWING ESCAPE HATCHES
DETAIL II**

ITEM	DESCRIPTION	GAGE	MATERIAL	STRINGER TYPE	REF DWG	EFFECTIVITY
1	STRINGER A	1.95	7050-T76511	■	144N8150	
2	STRINGER A	0.125	7075-T6	∩	144N3110	
3	STRINGER A	0.112	7075-T6	∩	144N3110	
4	STRINGER A	0.090	7075-T6	∩	144N3110	
5	STRINGER		BAC1517-2154 7075-T6511	└	144N3230	
6	STRINGER		BAC1517-2232 7075-T6511	└	144N3230	
7	STRINGER		BAC1509-100507 7075-T6511	∩	144N3242	

LIST OF MATERIALS FOR DETAIL II

**Section 44 Stringer Identification
Figure 1 (Sheet 3 of 3)**

IDENTIFICATION 1
Page 3
Jan 20/2005

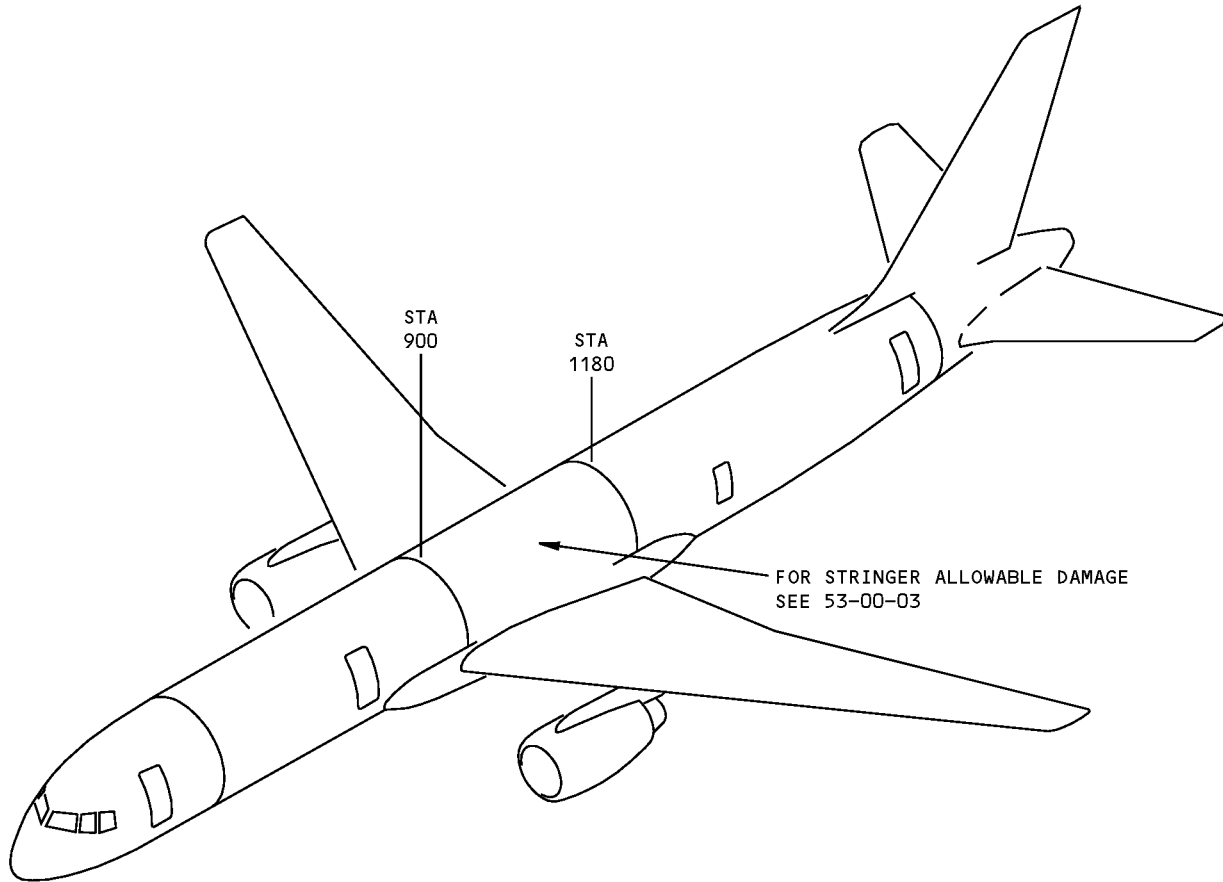
53-40-03

D634N201



757-200
STRUCTURAL REPAIR MANUAL

ALLOWABLE DAMAGE GENERAL - SECTION 44 - STRINGERS



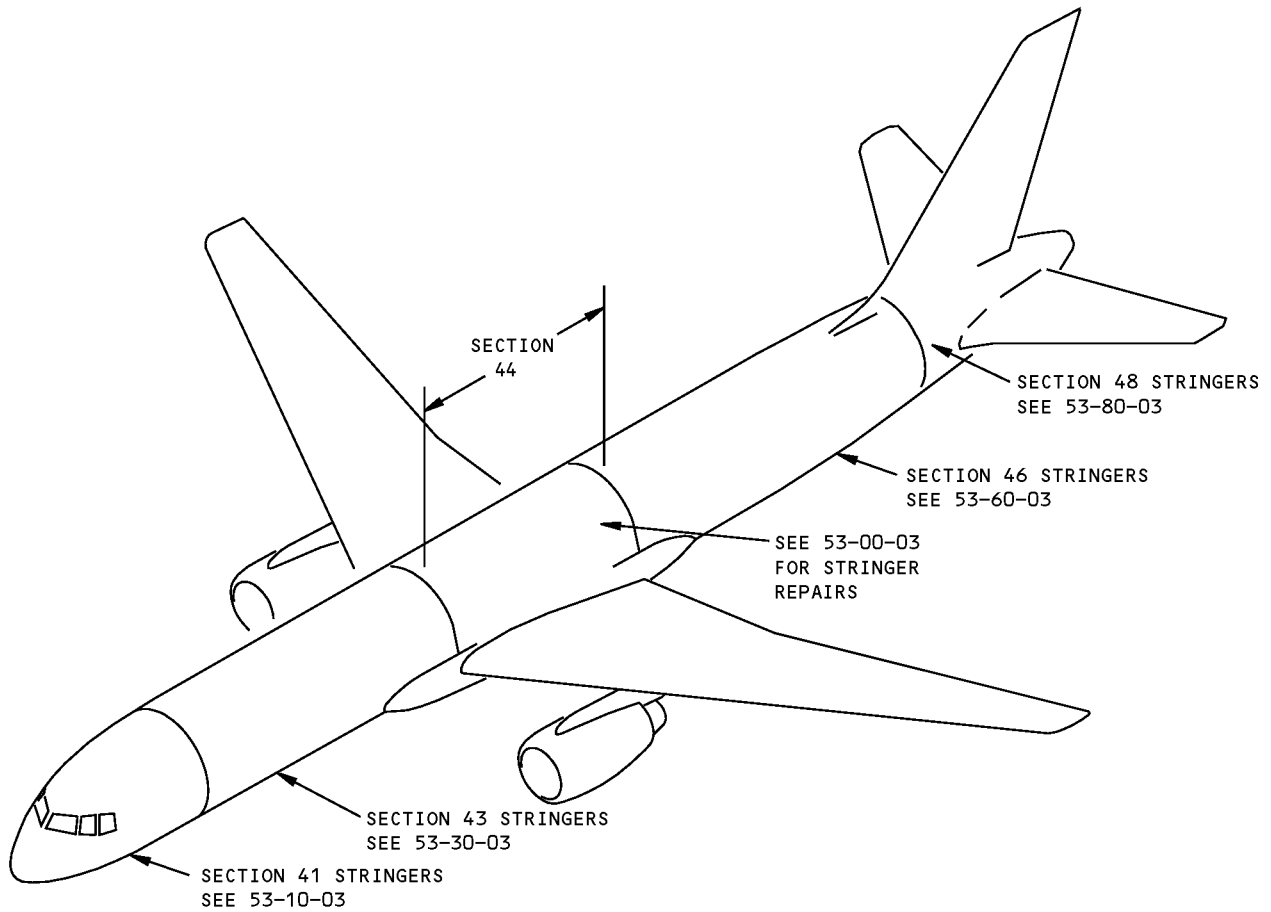
Section 44 Stringer Allowable Damage
Figure 101

D634N201

ALLOWABLE DAMAGE GENERAL
Page 101
53-40-03 Jan 20/2005

757-200
STRUCTURAL REPAIR MANUAL

REPAIR GENERAL - SECTION 44 - STRINGERS

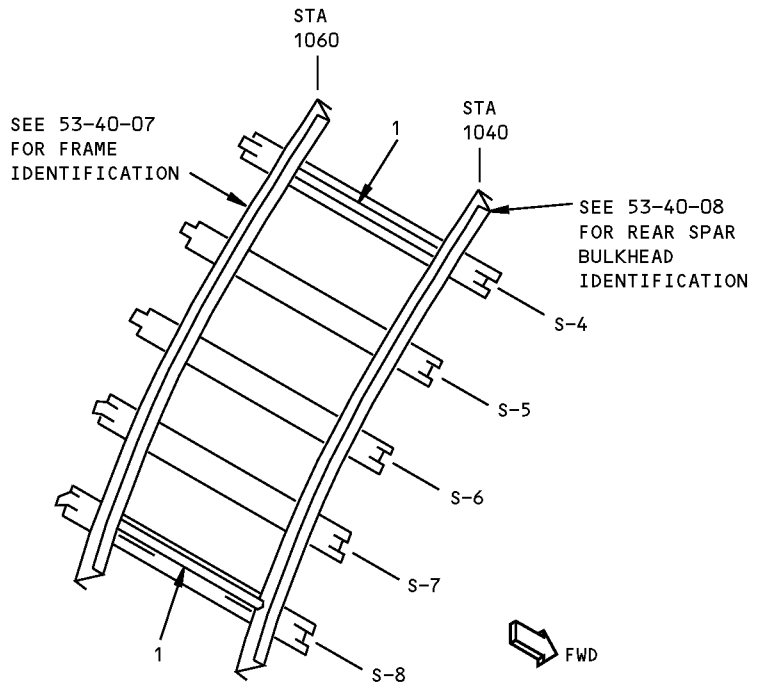
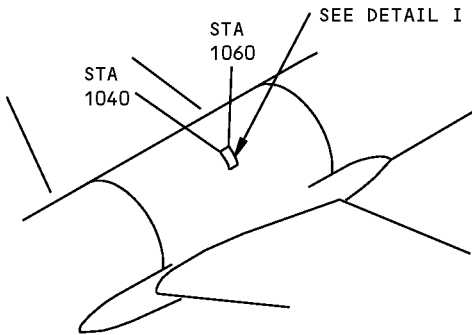


Section 44 Fuselage Stringer Repair
Figure 201

**757-200
STRUCTURAL REPAIR MANUAL**

IDENTIFICATION 1 - SECTION 44 - INTERCOSTALS

REF DWG
144N2404



LEFT SIDE IS SHOWN, RIGHT SIDE IS OPPOSITE
DETAIL I

ITEM	DESCRIPTION	GAGE	MATERIAL	EFFECTIVITY
1	INTERCOSTAL	0.040	7075-T6	

LIST OF MATERIALS FOR DETAIL I

**Section 44 Intercostal Identification
Figure 1**

IDENTIFICATION 1
Page 1
Jan 20/2005

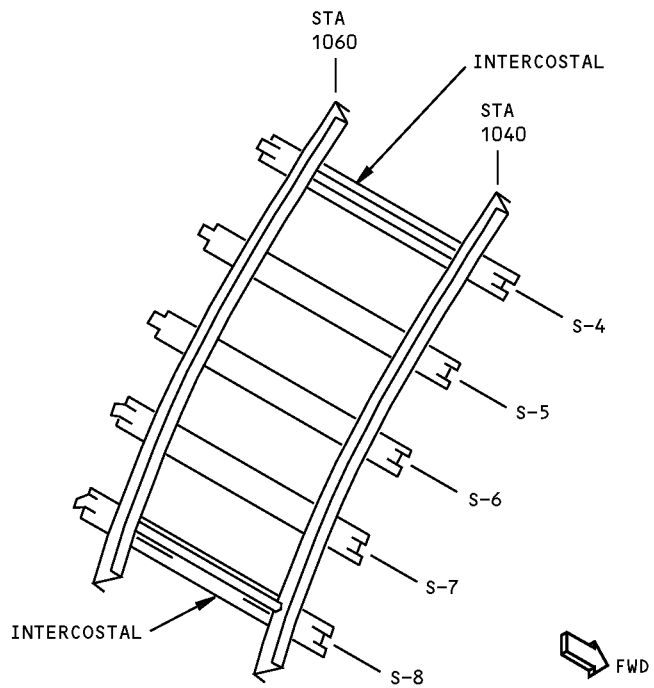
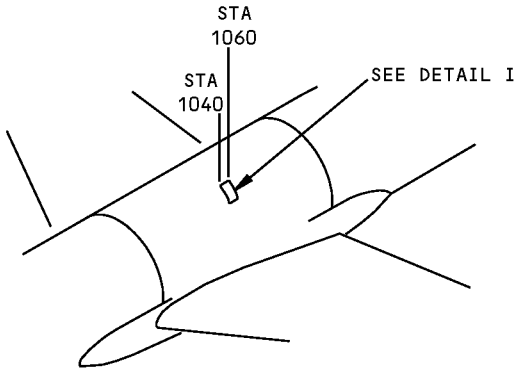
53-40-04

D634N201

**757-200
STRUCTURAL REPAIR MANUAL**

ALLOWABLE DAMAGE GENERAL - SECTION 44 - INTERCOSTALS

REF DWG
144N2404



LEFT SIDE SHOWN
RIGHT SIDE OPPOSITE
DETAIL I

NOTES

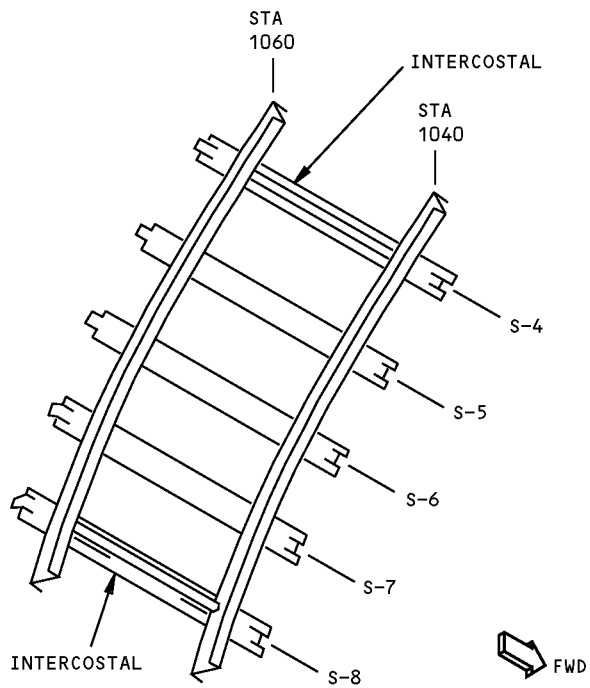
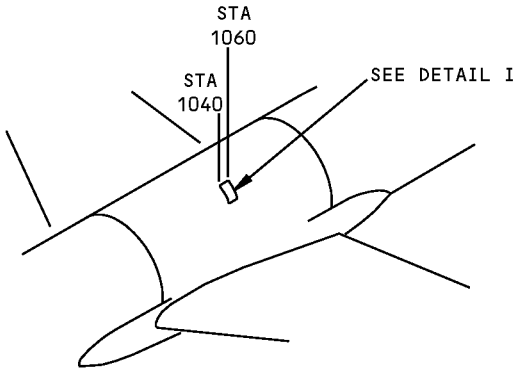
- REFER TO 53-00-04 FOR INTERCOSTAL ALLOWABLE DAMAGE DATA

**Section 44 Intercostal Allowable Damage
Figure 101**

**757-200
STRUCTURAL REPAIR MANUAL**

REPAIR GENERAL - SECTION 44 - INTERCOSTALS

REF DWG
144N2404



LEFT SIDE SHOWN
RIGHT SIDE OPPOSITE
DETAIL I

NOTES

- DAMAGED COMPONENTS MAY BE REPLACED OR REPAIRED. IF REPAIRS ARE TO BE MADE, SEE 51-70 FOR TYPICAL WEB, FORMED SECTION, OR EXTRUDED SECTION REPAIRS

**Section 44 Intercostal Repair
Figure 201**

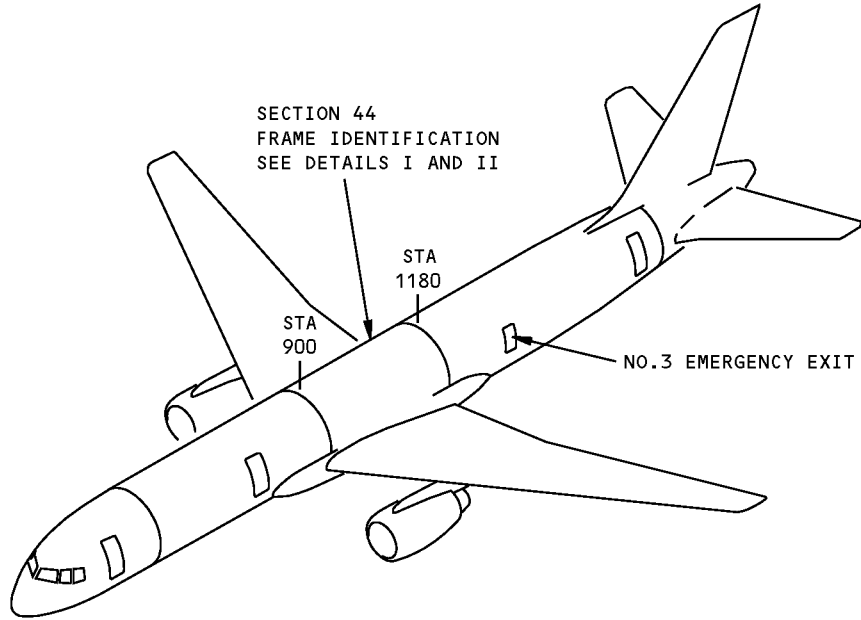
D634N201

53-40-04

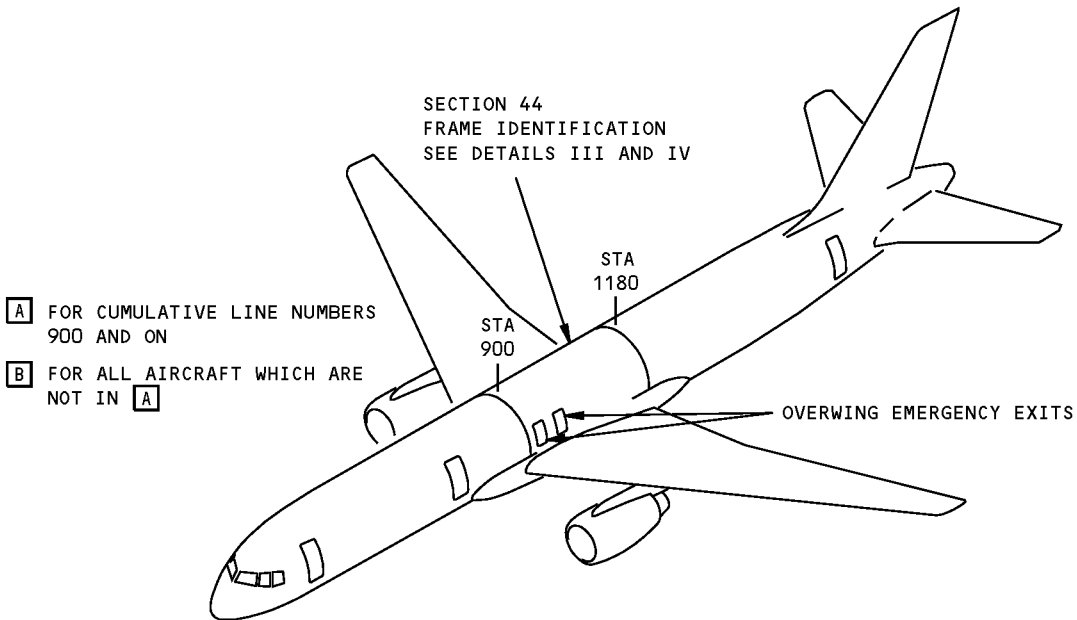
REPAIR GENERAL
Page 201
Jan 20/2005

**757-200
STRUCTURAL REPAIR MANUAL**

IDENTIFICATION 1 - SECTION 44 - FRAMES



**AIRPLANES WITH NO. 3 EMERGENCY EXIT
BASIC CONFIGURATION**

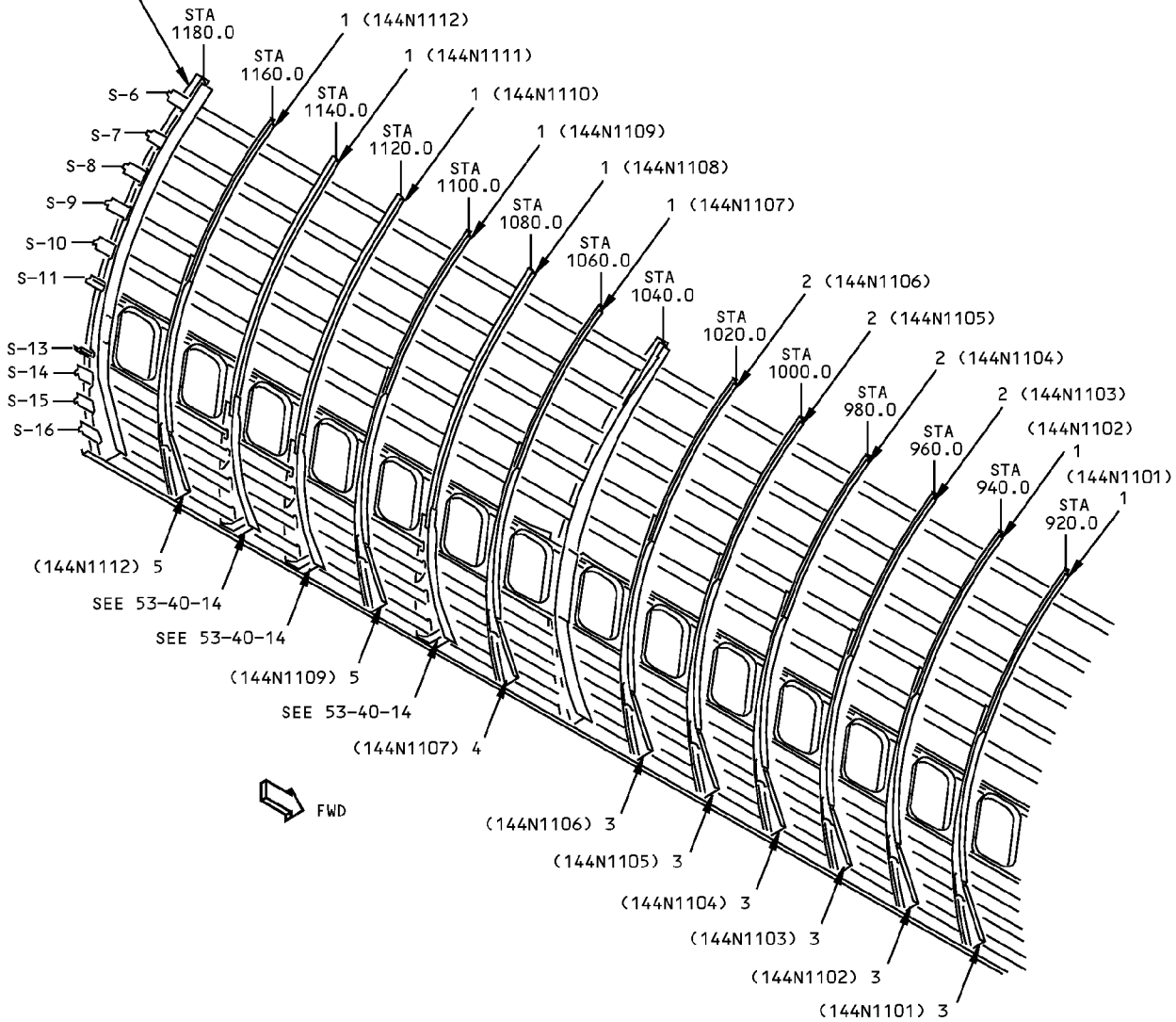


**AIRPLANES WITH OVERWING EMERGENCY EXITS
BASIC CONFIGURATION**

**Section 44 Frame Identification
Figure 1 (Sheet 1 of 7)**

**757-200
STRUCTURAL REPAIR MANUAL**

SEE 53-40-08
FOR SECTION 44
BULKHEAD IDENTIFICATION



AIRPLANES WITH NO. 3 EMERGENCY EXIT
LEFT SIDE SHOWN RIGHT SIDE OPPOSITE
DETAIL I

LIST OF
MATL

**Section 44 Frame Identification
Figure 1 (Sheet 2 of 7)**



**757-200
STRUCTURAL REPAIR MANUAL**

ITEM	DESCRIPTION	GAGE	MATERIAL	EFFECTIVITY
1	FRAME	0.080	7075-T6	B
		0.090	7057-T6	A
2	FRAME	0.090	7075-T6	
3	FRAME ASSEMBLY			
	WEB	0.090	2024-T3	
	FAILSAFE CHORD		BAC1503-100174 7075-T6 OR AND 10134-1407 7075-T6 BAC1503-100313, 7075-T62	B A
	INNER CHORD		BAC1503-100167 2024-T42 OR BAC1503-100577 2024-T42 BAC1514-451 2024-T42	B A
4	FRAME ASSEMBLY			
	WEB	0.090 0.125	2024-T3 2024-T3	B A
	FAILSAFE CHORD		BAC1503-100174 7075-T6 OR AND 10134-1407 7075-T6 BAC1503-100313 7075-T62	B A
	INNER CHORD		BAC1503-100182 2024-T42 BAC1514-82 2024-T42	B A
5	FRAME ASSEMBLY			
	WEB	0.090 0.100	2024-T3 2024-T3	B A
	FAILSAFE CHORD		BAC1503-100174 7075-T6 OR AND 10134-1407 7075-T6 BAC1503-100313 7075-T62	B A
	INNER CHORD		BAC1514-387 2024-T42 BAC1503-100258 2024-T42	B A

LIST OF MATERIALS FOR DETAIL I

**Section 44 Frame Identification
Figure 1 (Sheet 3 of 7)**

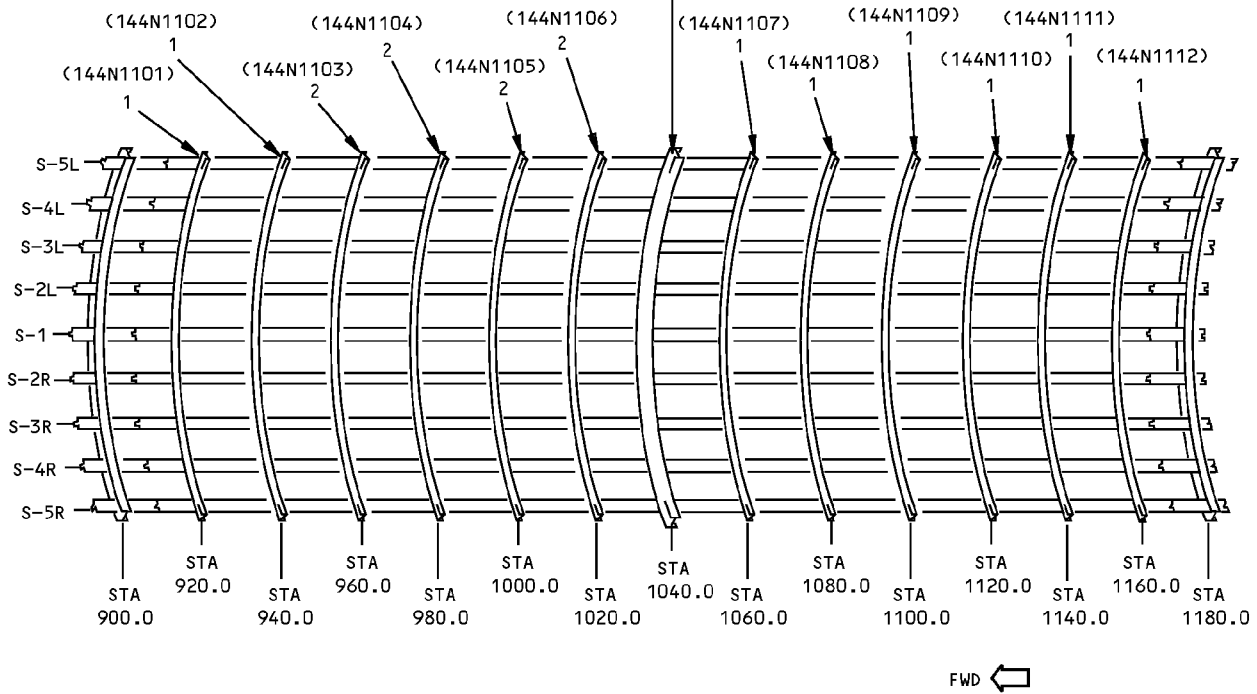
D634N201

53-40-07

IDENTIFICATION 1
Page 3
Jan 20/2005

**757-200
STRUCTURAL REPAIR MANUAL**

SEE 53-40-08
FOR SECTION 44
BULKHEAD IDENTIFICATION



**AIRPLANES WITH NO. 3 EMERGENCY EXIT
CROWN FRAMES
DETAIL II**

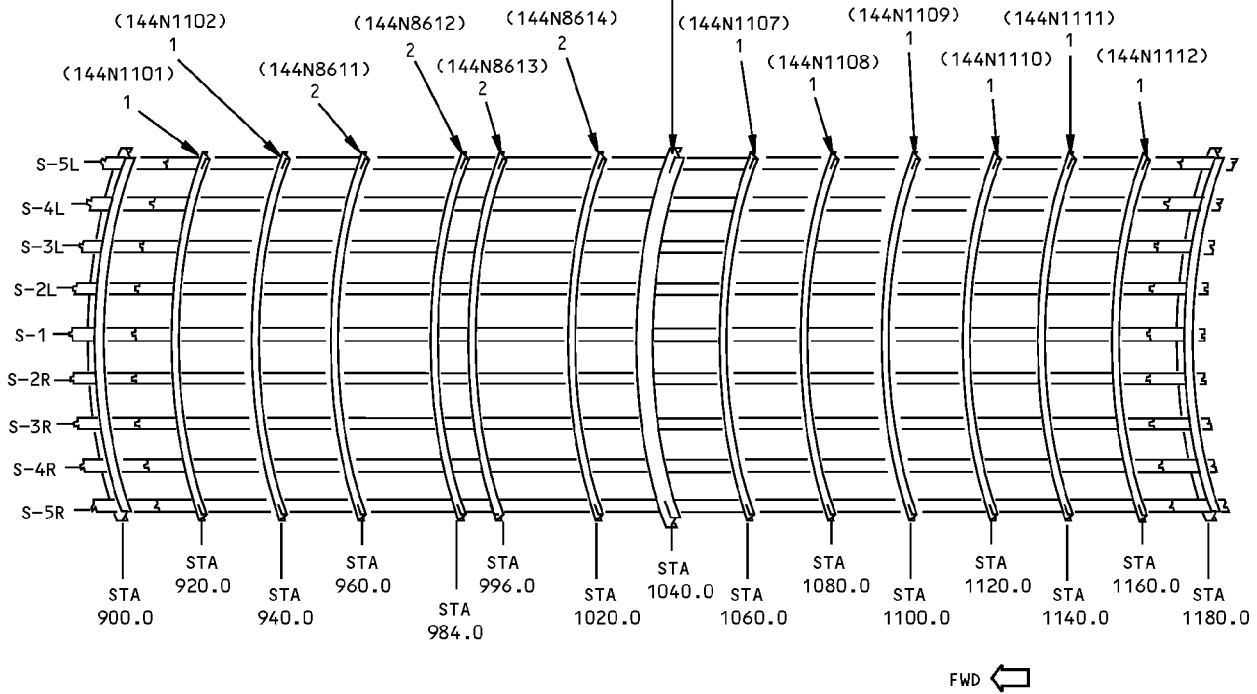
ITEM	DESCRIPTION	GAGE	MATERIAL	EFFECTIVITY
1	FRAME	0.080	7075-T6	
2	FRAME	0.090	7075-T6	

LIST OF MATERIALS FOR DETAIL II

**Section 44 Frame Identification
Figure 1 (Sheet 4 of 7)**

757-200 STRUCTURAL REPAIR MANUAL

SEE 53-40-08
FOR SECTION 44
BULKHEAD IDENTIFICATION



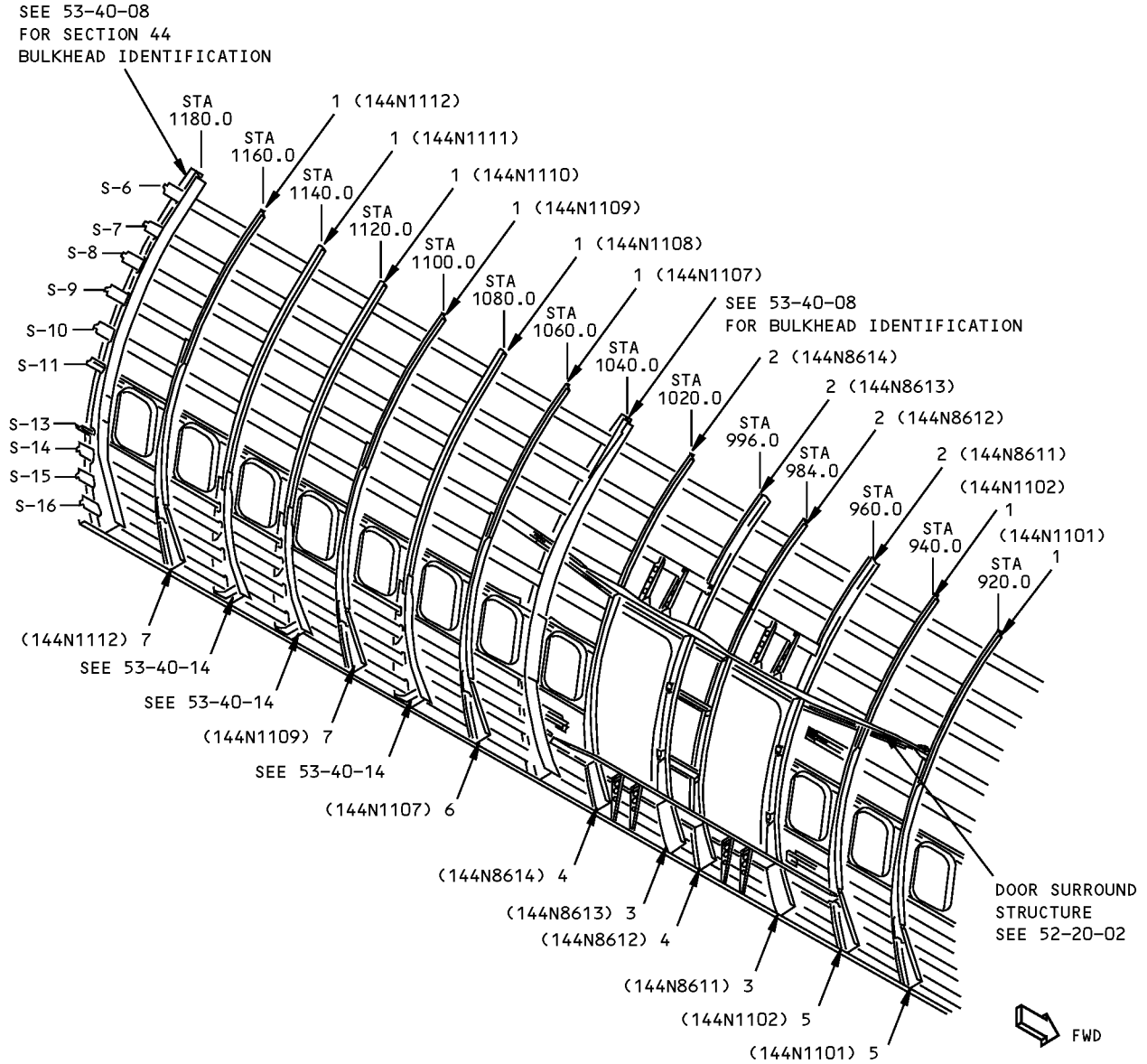
AIRPLANES WITH OVERWING EMERGENCY EXITS
CROWN FRAMES
DETAIL III

ITEM	DESCRIPTION	GAGE	MATERIAL	EFFECTIVITY
1	FRAME	0.080	7075-T6	
2	FRAME		BAC 1517-2297 7075-T6	

LIST OF MATERIALS FOR DETAIL III

**Section 44 Frame Identification
Figure 1 (Sheet 5 of 7)**

**757-200
STRUCTURAL REPAIR MANUAL**



AIRPLANES WITH OVERWING EMERGENCY EXITS
LEFT SIDE SHOWN RIGHT SIDE OPPOSITE
DETAIL IV

LIST OF
MATL

**Section 44 Frame Identification
Figure 1 (Sheet 6 of 7)**



**757-200
STRUCTURAL REPAIR MANUAL**

ITEM	DESCRIPTION	GAGE	MATERIAL	EFFECTIVITY
1	FRAME	0.080	7075-T6	
2	FRAME		BAC1517-2297 7075-T6	
3	FRAME ASSY CHORD - INBD CHORD - OUTBD WEB - FWD WEB - AFT	0.125 0.10	BAC1505-101309 2024-T42 OR BAC1505-101130 2024-T42 BAC1503-100756 2024-T42 OR BAC1503-100167 2024-T42 BAC1514-2651 2024-T42 2024-T3 2024-T3	B A
4	FRAME ASSY CHORD - INBD CHORD - OUTBD WEB	0.10	BAC1503-100755 2024-T42 OR BAC1503-100378 2024-T42 BAC1503-100756 2024-T42 OR BAC1503-100167 2024-T42 BAC 1514-2651 2024-T42 2024-T3	B A
5	FRAME ASSY FAILSAFE INNER CHORD WEB	0.090	AND10134-1407 7075-T6 BAC1503-100167 2024-T42 2024-T3	
6	FRAME ASSY FAILSAFE CHORD INNER CHORD WEB	0.090	BAC1503-100174 7075-T6 OR AND10134-1407 7075-T6 BAC1503-100182 2024-T42 OR BAC1503-100167 2024-T42 2024-T3	
7	FRAME ASSY FAILSAFE CHORD INNER CHORD WEB	0.090	BAC1503-100174 7075-T6511 OR AND10134-1407 7075-T6511 BAC1514-387 2024-T42 OR AND10134-3006 2024-T42 2024-T3	

LIST OF MATERIALS FOR DETAIL IV

**Section 44 Frame Identification
Figure 1 (Sheet 7 of 7)**

IDENTIFICATION 1
Page 7
Jan 20/2005

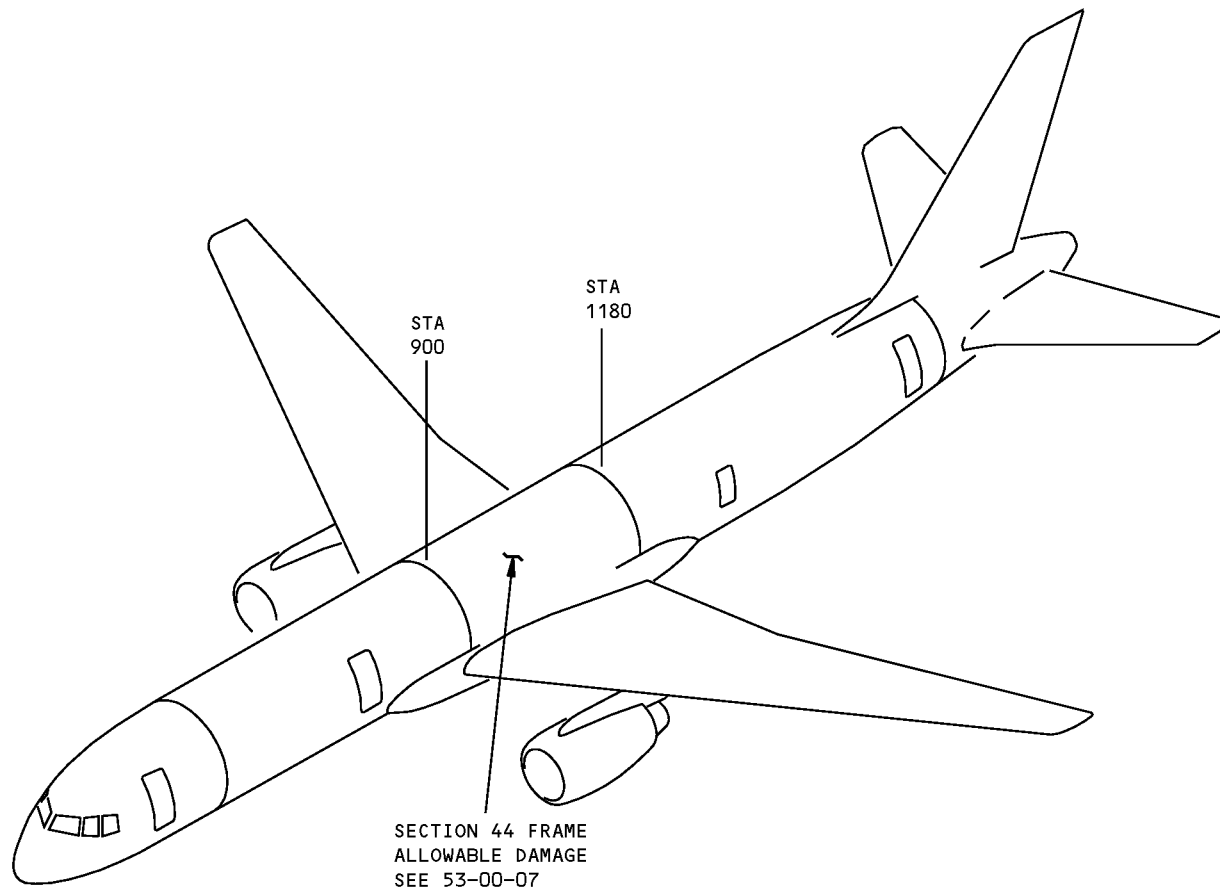
53-40-07

D634N201



757-200
STRUCTURAL REPAIR MANUAL

ALLOWABLE DAMAGE GENERAL - SECTION 44 - FRAMES



Section 44 Frame Allowable Damage
Figure 101

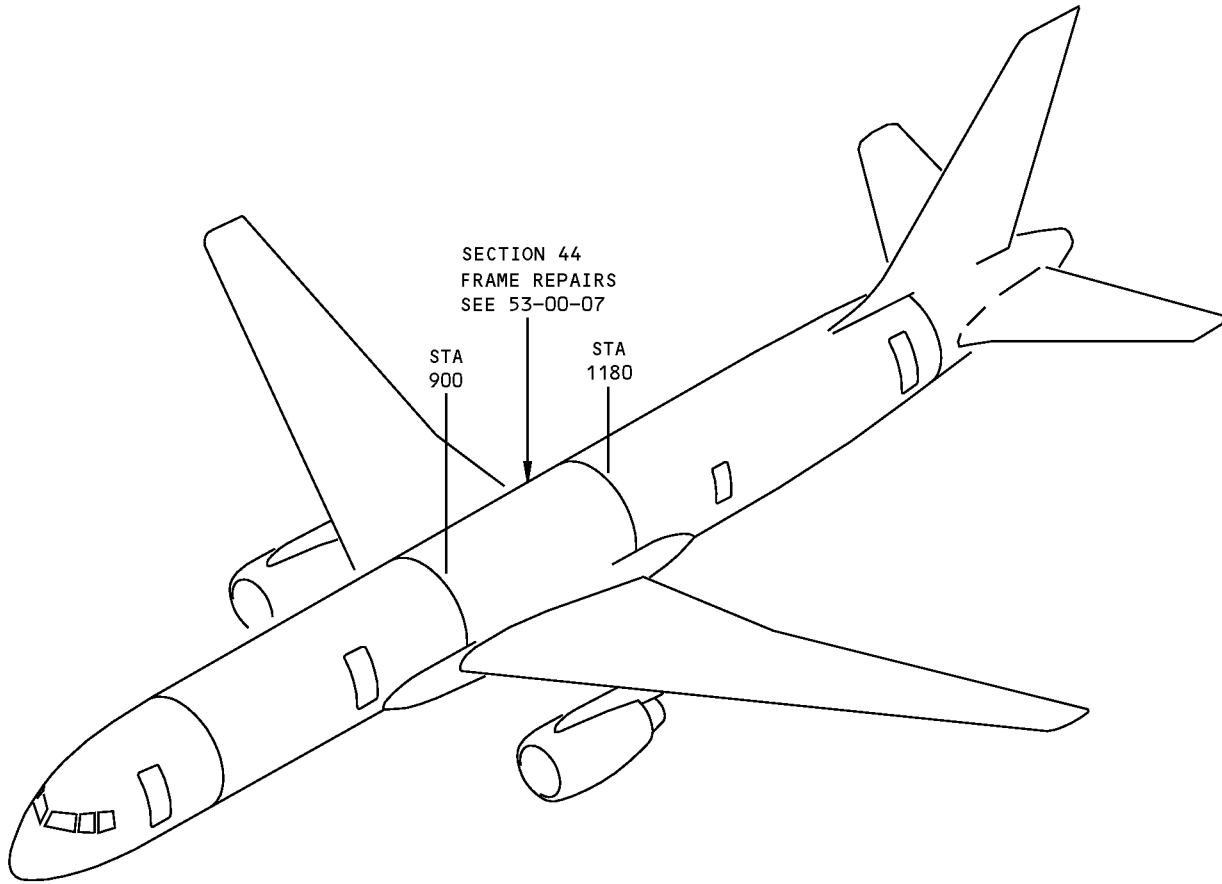
D634N201

ALLOWABLE DAMAGE GENERAL
Page 101
53-40-07
Jan 20/2005



757-200
STRUCTURAL REPAIR MANUAL

REPAIR GENERAL - SECTION 44 - FRAMES



Section 44 Fuselage Frame Repairs
Figure 201

D634N201

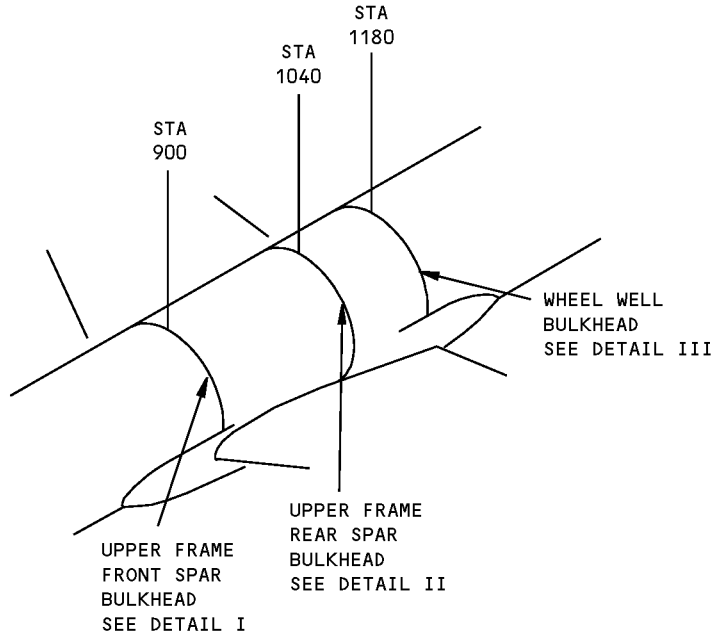
53-40-07

REPAIR GENERAL
Page 201
Jan 20/2005



757-200
STRUCTURAL REPAIR MANUAL

IDENTIFICATION 1 - SECTION 44 - BULKHEAD STRUCTURE



NOTES

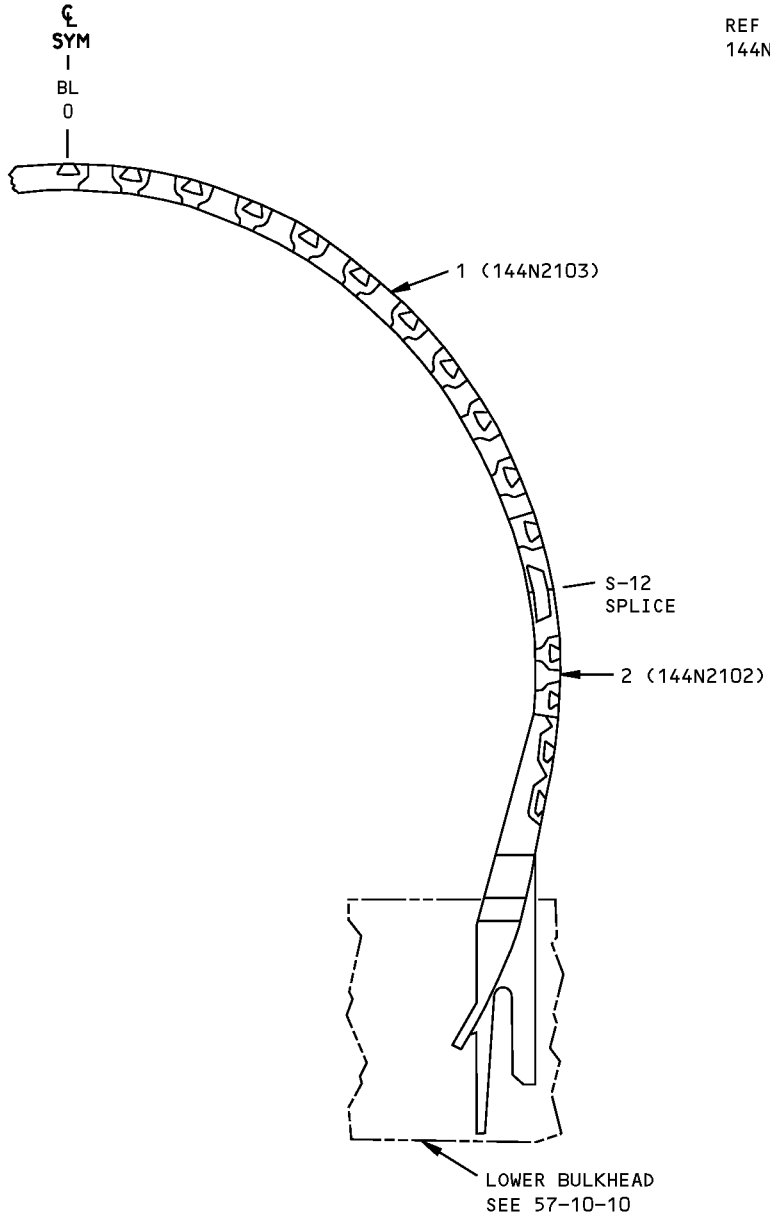
A FOR CUM LINE NUMBERS:
1 THRU 36,38,40

B FOR AIRPLANES NOT LISTED IN **A**

Section 44 Bulkhead Structure Identification
Figure 1 (Sheet 1 of 4)

**757-200
STRUCTURAL REPAIR MANUAL**

REF DWG
144N2101



FRONT VIEW STA 900
LEFT SIDE IS SHOWN, RIGHT SIDE IS OPPOSITE
DETAIL I

ITEM	DESCRIPTION	GAGE	MATERIAL	EFFECTIVITY
1	RING		BAC1518-816 7075-T73	
2	SIDE FITTING		7075-T73 FORGING	

LIST OF MATERIALS FOR DETAIL I

**Section 44 Bulkhead Structure Identification
Figure 1 (Sheet 2 of 4)**

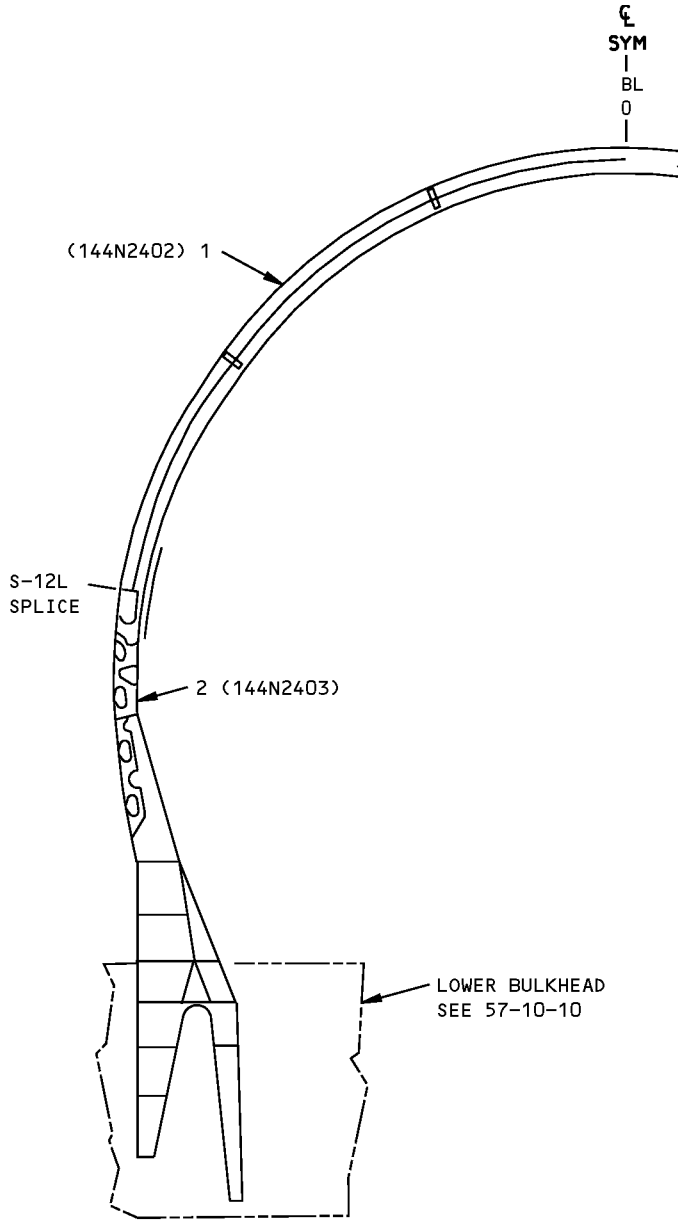
IDENTIFICATION 1
Page 2
Jan 20/2005

53-40-08

D634N201

**757-200
STRUCTURAL REPAIR MANUAL**

REF DWG
144N2401



REAR VIEW STA 1140
LEFT SIDE IS SHOWN, RIGHT SIDE IS OPPOSITE
DETAIL II

ITEM	DESCRIPTION	GAGE	MATERIAL	EFFECTIVITY
1	RING		BAC1506-3209 7075-T6	
2	SIDE FITTING		7175-T736 FORGING	

LIST OF MATERIALS FOR DETAIL II

**Section 44 Bulkhead Structure Identification
Figure 1 (Sheet 3 of 4)**

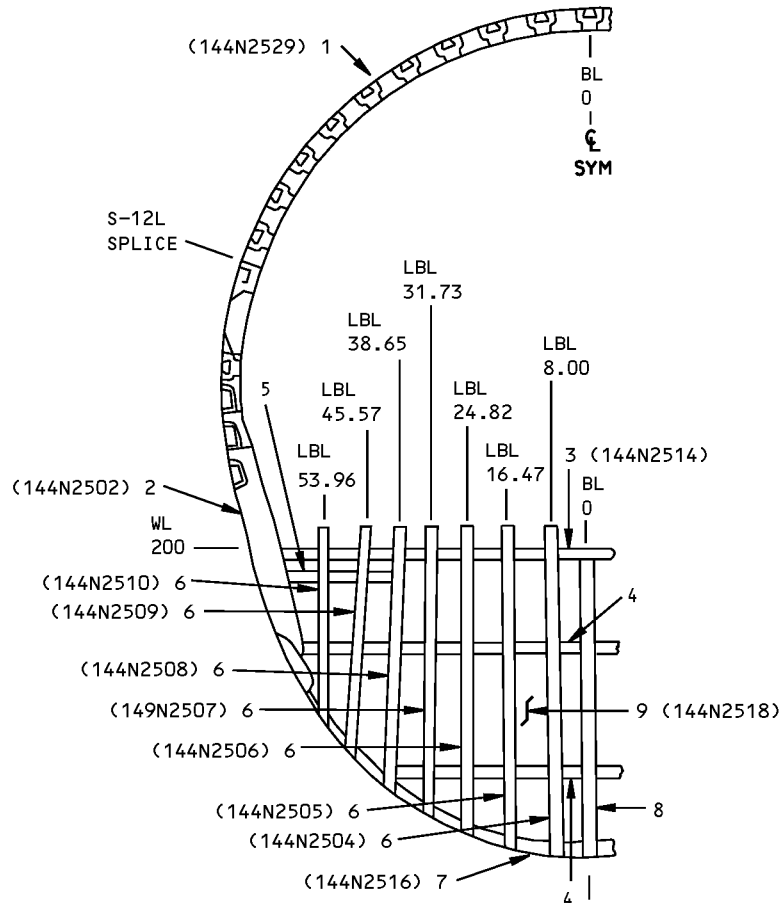
IDENTIFICATION 1
Page 3
Jan 20/2005

53-40-08

D634N201

**757-200
STRUCTURAL REPAIR MANUAL**

REF DWG
144N2503



**MLG WHEEL WELL BULKHEAD STA 1180
REAR VIEW
LEFT SIDE IS SHOWN, RIGHT SIDE IS OPPOSITE
DETAIL III**

ITEM	DESCRIPTION	GAGE	MATERIAL	EFFECTIVITY
1	RING		BAC1518-816A 7075-T73511	
2	SIDE FITTING		7075-T73 FORGING	
3	UPPER CHORD (2 NESTED)	0.100	2024-T42	
4	TEE		AND10136-3001 7075-T6511	
5	FAILSAFE SPAR		AND10133-2003 7075-T6511	
6	STIFFENER		BAC1518-653 7075-T6511 (CHEM-MILLED TO 0.064 MIN)	
7	LOWER CHORD (2 NESTED)	0.125	2024-T42	
8	TEE		BAC1505-100667 7075-T6511	
9	WEB	0.100 0.090	2024-T3 (CHEM-MILLED TO 0.080 MIN) 2024-T3 (CHEM-MILLED TO 0.070 MIN)	A B

LIST OF MATERIALS FOR DETAIL III

**Section 44 Bulkhead Structure Identification
Figure 1 (Sheet 4 of 4)**

IDENTIFICATION 1
Page 4
Jan 20/2005

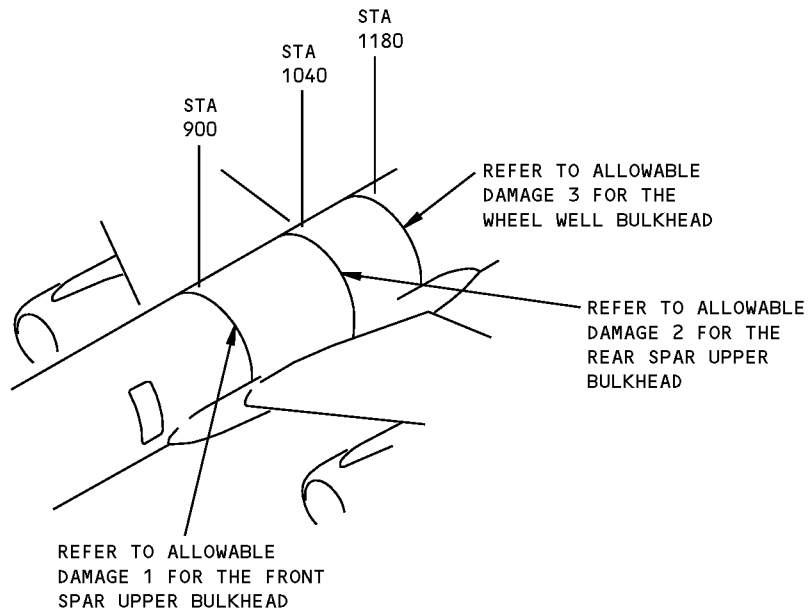
53-40-08

D634N201



757-200
STRUCTURAL REPAIR MANUAL

ALLOWABLE DAMAGE GENERAL - SECTION 44 - BULKHEAD STRUCTURE



Section 44 Bulkhead Structure Allowable Damage Index
Figure 101

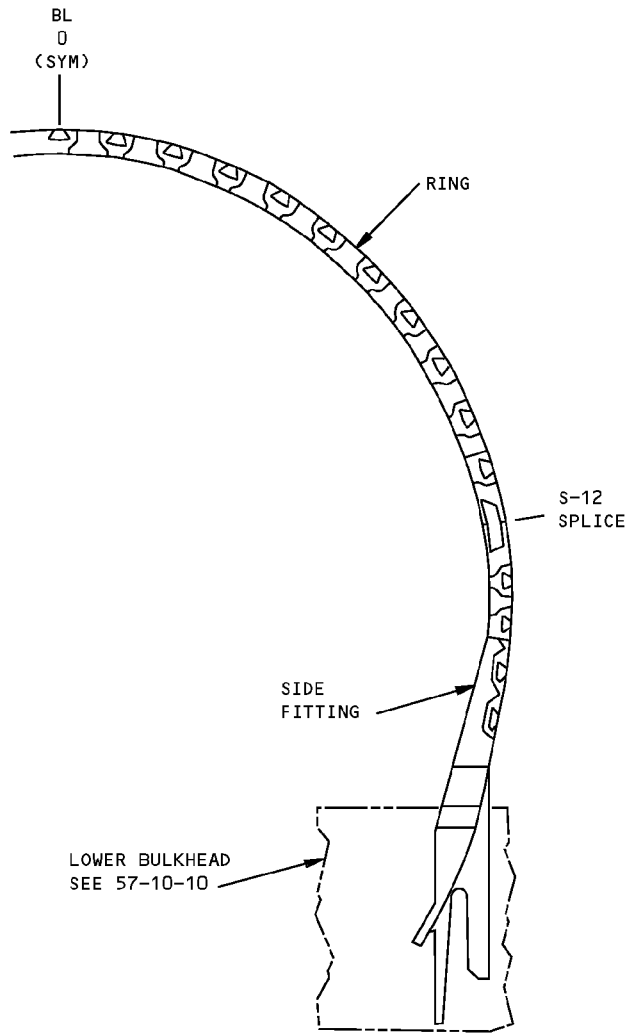
D634N201

ALLOWABLE DAMAGE GENERAL
Page 101
53-40-08
Jan 20/2007

**757-200
STRUCTURAL REPAIR MANUAL**

ALLOWABLE DAMAGE 1 - STATION 900 FRONT SPAR BULKHEAD

REF DWG
144N2101



MATERIAL :
ALUMINUM

FRONT VIEW

**Station 900 Front Spar Bulkhead Allowable Damage
Figure 101 (Sheet 1 of 3)**

D634N201

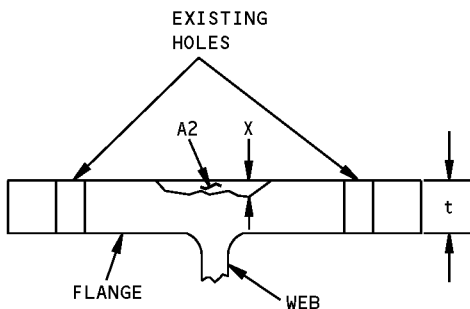
ALLOWABLE DAMAGE 1
Page 101
53-40-08
Jan 20/2005

**757-200
STRUCTURAL REPAIR MANUAL**

ITEM	CRACKS	NICKS, GOUGES AND CORROSION	DENTS	HOLES
RING	A	B	NOT ALLOWED	NOT ALLOWED
SIDE FITTING	A	B	NOT ALLOWED	NOT ALLOWED

NOTES

- REFINISH REWORKED AREAS PER 51-20 OF THE MAINTENANCE MANUAL
- A** CRACKS NOT ALLOWED EXCEPT FOR EDGE CRACKS, WHICH MUST BE REMOVED PER DETAILS II AND IV. MAX DEPTH 0.10 INCH. SHOT PEEN REWORKED AREAS PER 20-10-03 OF THE COMPONENT MAINTENANCE MANUAL WITH SHOT NO. 230-550, INTENSITY .008A. **C**
- B** REMOVE DAMAGE PER DETAILS II, III, IV, OR V. THE TOTAL CROSS-SECTIONAL AREA REMOVED MUST NOT EXCEED 10% OF THE ORIGINAL CROSS-SECTIONAL AREA OF THE FLANGE OR WEB AS APPROPRIATE. SEE DETAIL I. SHOT PEEN REWORKED AREAS PER 20-10-03 OF THE COMPONENT MAINTENANCE MANUAL WITH SHOT NO. 230-550, INTENSITY .008A. **C**
- C** SHOT INTENSITIES SHOWN FOR MANUFACTURED COMPONENTS. SEE 51-20-06 FOR SHOT PEEN INTENSITIES REQUIRED DUE TO THICKNESS REDUCTION RESULTING FROM REWORK.



CROSS-SECTIONAL VIEW

A1 = NET AREA (NOT INCLUDING WEB)
= TOTAL AREA - EXISTING HOLES

A2 = AREA REMOVED FOR NICKS,
GOUGES OR CORROSION

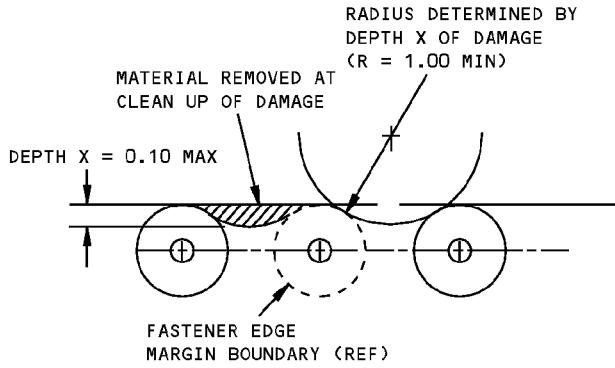
X = NOT TO EXCEED 25% OF
THICKNESS t

$$\left(\frac{A2}{A1} \right)_{\text{MAX}} = 10\%$$

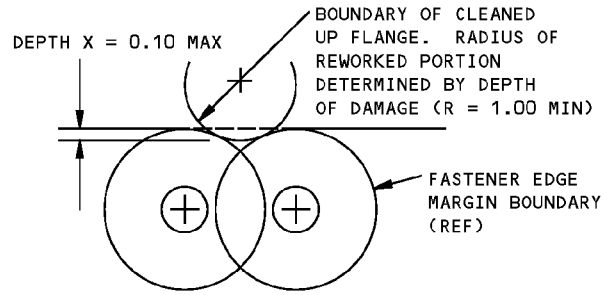
DETAIL I

**Station 900 Front Spar Bulkhead Allowable Damage
Figure 101 (Sheet 2 of 3)**

STRUCTURAL REPAIR MANUAL

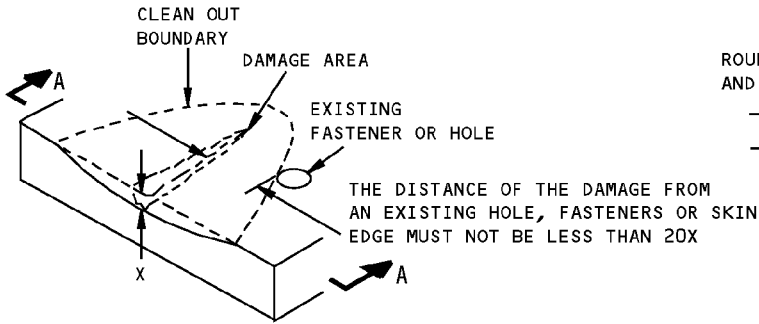


DAMAGE CLEAN UP OF EDGES WHERE FASTENER EDGE MARGINS DO NOT OVERLAP

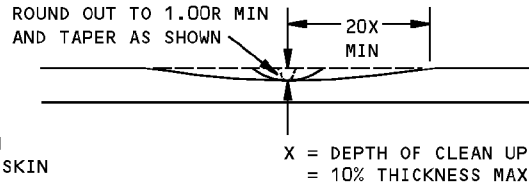


DAMAGE CLEAN UP OF EDGES WHERE FASTENER EDGE MARGINS OVERLAP

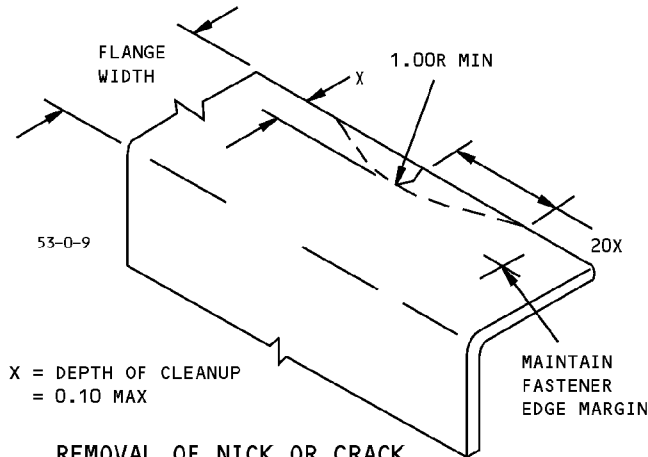
DETAIL II



REMOVAL OF NICK, GOUGE AND SCRATCH DAMAGE ON A SURFACE
DETAIL III

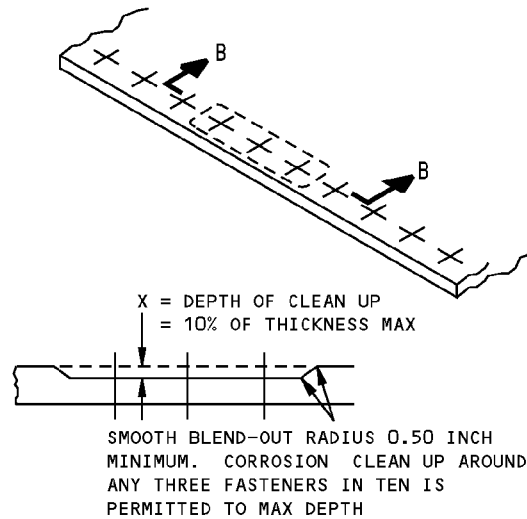


SECTION A-A



REMOVAL OF NICK OR CRACK DAMAGE ON AN EDGE

DETAIL IV



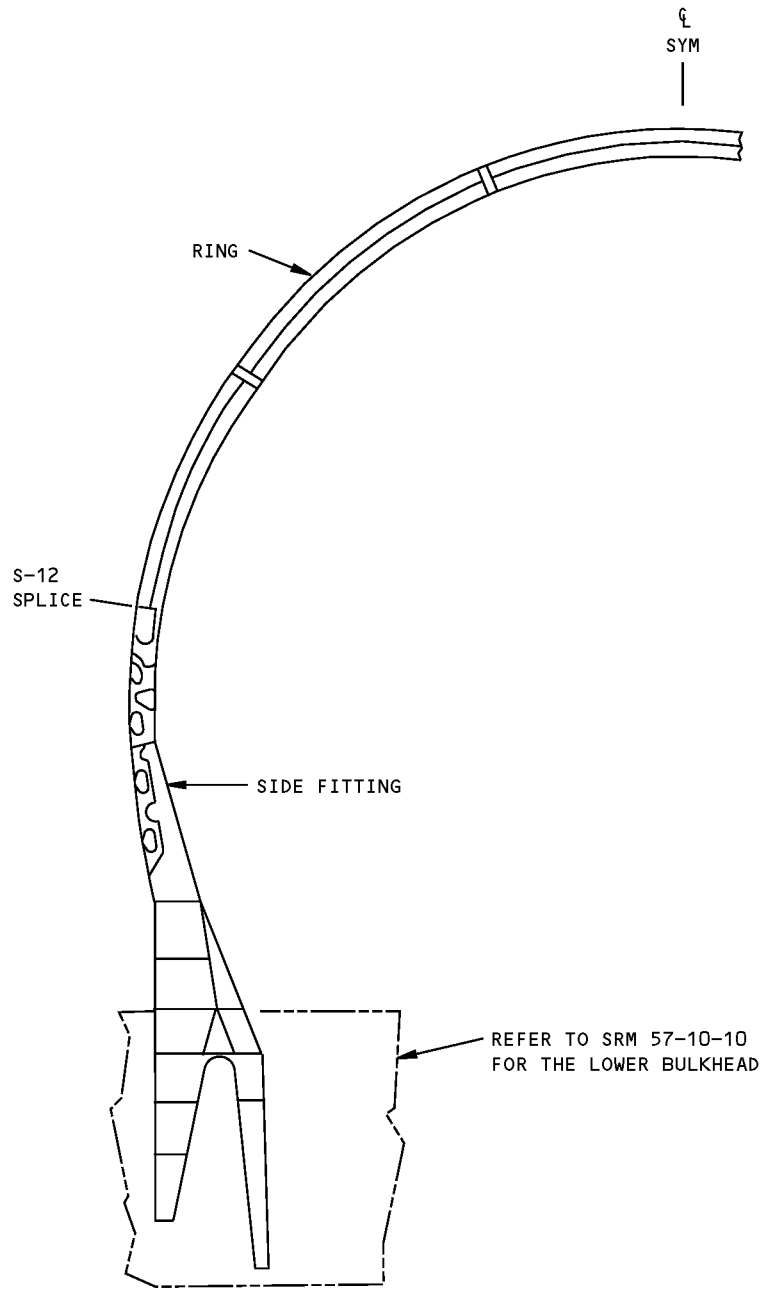
SECTION B-B
CORROSION CLEANUP
DETAIL V

Station 900 Front Spar Bulkhead Allowable Damage
Figure 101 (Sheet 3 of 3)

**757-200
STRUCTURAL REPAIR MANUAL**

ALLOWABLE DAMAGE 2 - STA 1040 REAR SPAR BULKHEAD

REF DWG
144N2401



REAR VIEW

MATERIAL: ALUMINUM

**Sta 1040 Rear Spar Bulkhead Allowable Damage
Figure 101 (Sheet 1 of 3)**

D634N201

ALLOWABLE DAMAGE 2
53-40-08
Page 101
Jan 20/2005



757-200
STRUCTURAL REPAIR MANUAL

DESCRIPTION	CRACKS	NICKS, GOUGES AND CORROSION	DENTS	HOLES AND PUNCTURES
RING	A	C	NOT ALLOWED	NOT ALLOWED
SIDE FITTING	B	D	NOT ALLOWED	NOT ALLOWED

NOTES

- REFINISH REWORKED AREAS PER 51-20 OF THE MAINTENANCE MANUAL

A CRACKS NOT ALLOWED EXCEPT FOR EDGE CRACKS WHICH MUST BE REMOVED PER DETAILS I AND III. MAX DEPTH 0.10 INCH. SHOT PEEN REWORKED AREAS PER 20-10-03 OF THE COMPONENT MAINTENANCE MANUAL WITH SHOT NO. 230-550, INTENSITY .008A E

B CRACKS NOT ALLOWED EXCEPT FOR EDGE CRACKS, WHICH MUST BE REMOVED PER DETAILS I AND III. MAX DEPTH 0.10 INCH. SHOT PEEN REWORKED AREAS PER 20-10-03 OF THE COMPONENT MAINTENANCE MANUAL WITH SHOT NO. 230-550, INTENSITY .014 E

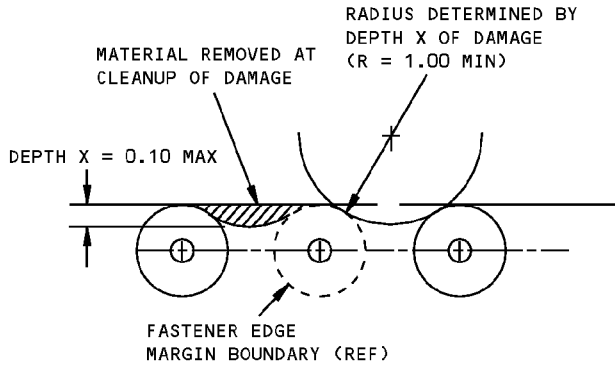
C REMOVE DAMAGE PER DETAILS I, II, III AND IV. THE TOTAL CROSS-SECTIONAL AREA REMOVED MUST NOT EXCEED 10% OF THE ORIGINAL CROSS-SECTIONAL AREA OF THE FLANGE. SHOT PEEN REWORKED AREAS PER 20-10-03 OF THE COMPONENT MAINTENANCE MANUAL WITH SHOT NO. 230-550, INTENSITY .008A E

D REMOVE DAMAGE PER DETAILS I, II, III AND IV. THE TOTAL CROSS-SECTIONAL AREA REMOVED MUST NOT EXCEED 10% OF THE ORIGINAL CROSS-SECTIONAL AREA OF THE FLANGE. SHOT PEEN REWORKED AREAS PER 20-10-03 OF THE COMPONENT MAINTENANCE MANUAL WITH SHOT NO. 230-550, INTENSITY .014A E

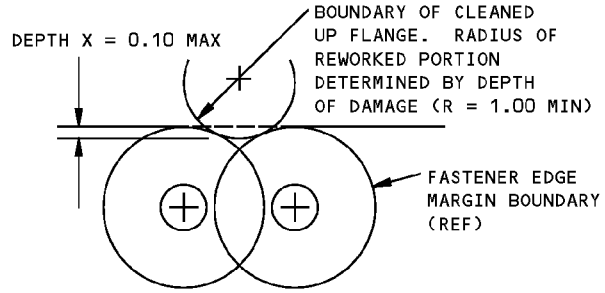
E SHOT PEEN INTENSITIES SHOWN FOR MANUFACTURED COMPONENTS. SEE 51-20-06 FOR SHOT PEEN INTENSITIES REQUIRED DUE TO THICKNESS REDUCTION RESULTING FROM REWORK

Sta 1040 Rear Spar Bulkhead Allowable Damage
Figure 101 (Sheet 2 of 3)

STRUCTURAL REPAIR MANUAL

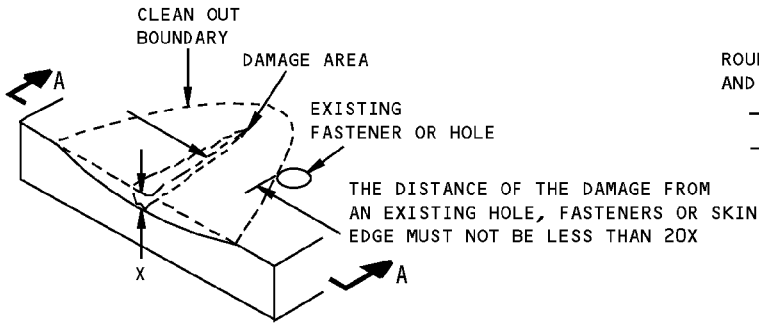


DAMAGE CLEANUP OF EDGES WHERE FASTENER EDGE MARGINS DO NOT OVERLAP

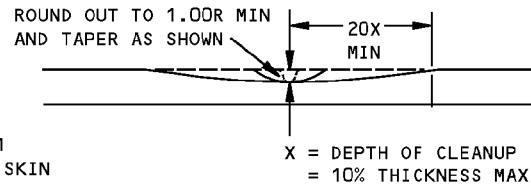


DAMAGE CLEANUP OF EDGES WHERE FASTENER EDGE MARGINS OVERLAP

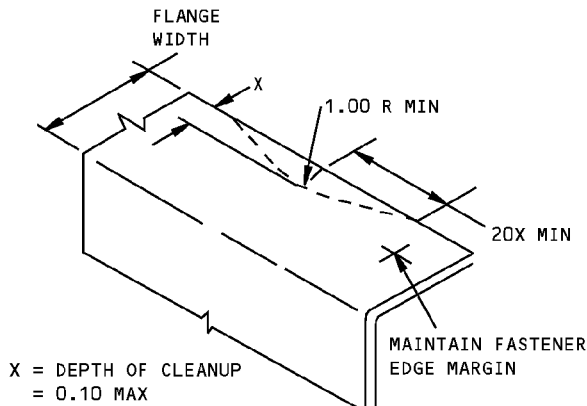
DETAIL I



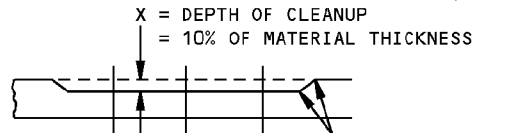
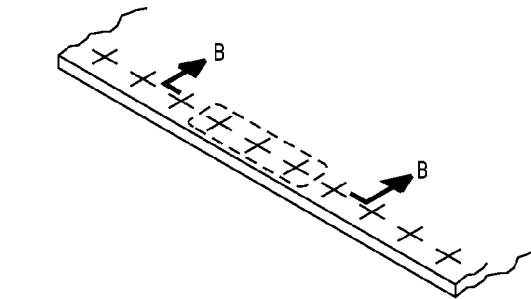
**REMOVAL OF NICK, GOUGE AND SCRATCH DAMAGE ON A SURFACE
DETAIL II**



SECTION A-A



**REMOVAL OF NICK OR CRACK DAMAGE ON AN EDGE
DETAIL III**



SMOOTH BLEND-OUT RADIUS 0.50 INCH MINIMUM. CORROSION CLEANUP AROUND ANY THREE FASTENERS IN TEN IS PERMITTED TO MAX DEPTH X

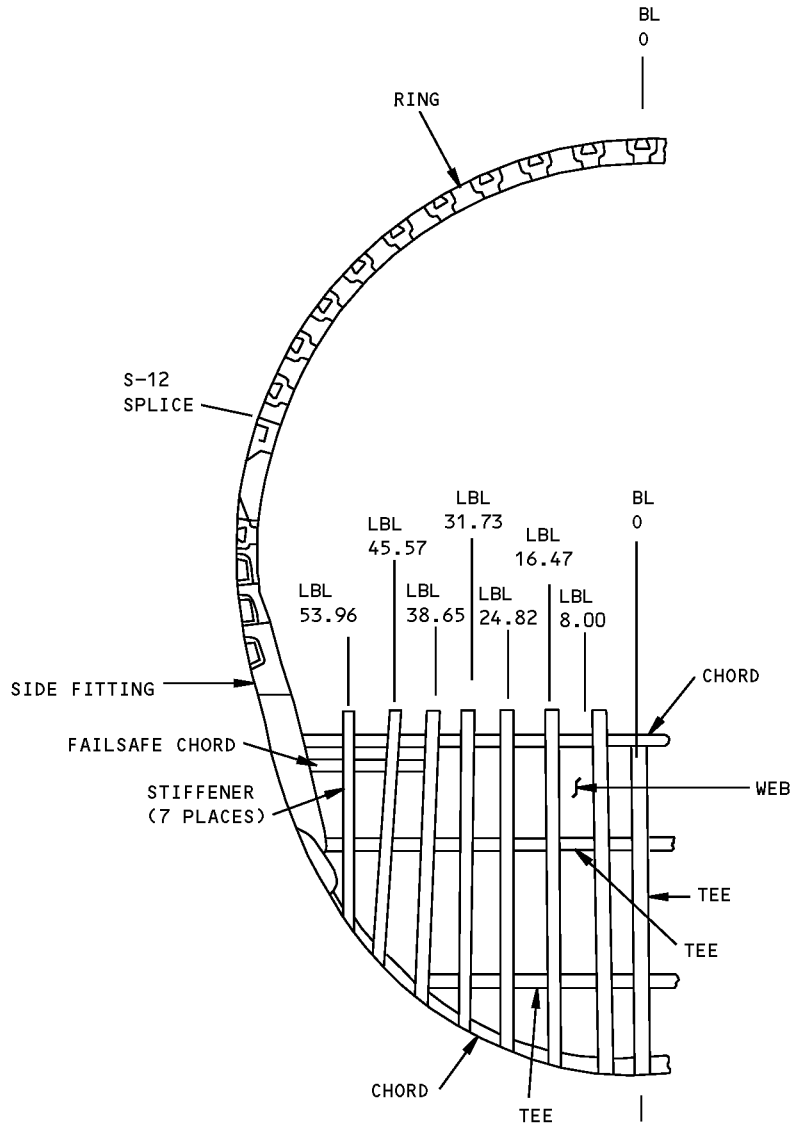
**SECTION B-B
CORROSION CLEANUP
DETAIL IV**

**Sta 1040 Rear Spar Bulkhead Allowable Damage
Figure 101 (Sheet 3 of 3)**

**757-200
STRUCTURAL REPAIR MANUAL**

ALLOWABLE DAMAGE 3 - STA 1180 WHEEL WELL BULKHEAD

REF DWG
144N2503



MATERIAL: ALUMINUM

**Sta 1180 Wheel Well Bulkhead Allowable Damage
Figure 101 (Sheet 1 of 3)**

D634N201

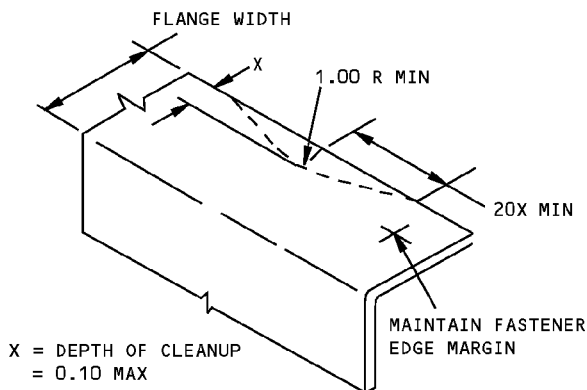
ALLOWABLE DAMAGE 3
Page 101
53-40-08
Jan 20/2005

**757-200
STRUCTURAL REPAIR MANUAL**

DESCRIPTION	CRACKS	NICKS, GOUGES AND CORROSION	DENTS	HOLES AND PUNCTURES
RING	A	C	NOT ALLOWED	NOT ALLOWED
SIDE FITTING	A	C	NOT ALLOWED	NOT ALLOWED
CHORDS	B	E	NOT ALLOWED	NOT ALLOWED
WEB	B	E	SEE DETAIL IV	F
STIFFENERS	B	E	NOT ALLOWED	F
TEES	B	E	NOT ALLOWED	F
FAILSAFE SPAR	B	D	NOT ALLOWED	NOT ALLOWED

NOTES

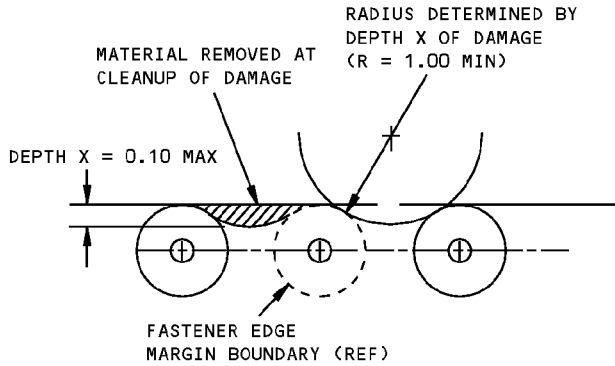
- REFINISH REWORKED AREAS PER 51-20 OF THE MAINTENANCE MANUAL
- A CRACKS NOT ALLOWED EXCEPT FOR EDGE CRACKS, WHICH MUST BE REMOVED PER DETAILS I AND II. SHOT PEEN REWORKED AREAS PER 20-10-03 OF THE COMPONENT MAINTENANCE MANUAL WITH SHOT NO. 230-550.
- B CRACKS NOT ALLOWED EXCEPT FOR EDGE CRACKS WHICH MUST BE REMOVED PER DETAILS I AND II.
- C REMOVE DAMAGE PER DETAILS I, II, III AND V. SHOT PEEN REWORKED AREAS PER 20-10-03 OF THE COMPONENT MAINTENANCE MANUAL WITH SHOT NO. 230-550. G
- D REMOVE DAMAGE PER DETAILS I, II AND III
- E REMOVE DAMAGE PER DETAILS I, II, III AND V
- F CLEAN OUT DAMAGE UP TO 0.25 MAX DIA AND NOT CLOSER THAN 1.0 INCH TO FASTENER HOLE, MATERIAL EDGE OR OTHER DAMAGE. FILL HOLE WITH A 2117-T3 OR T4 ALUMINUM RIVET INSTALLED WET WITH BMS 5-95 SEALANT. ALL OTHER HOLES TO BE REPAIRED
- G SHOT PEEN INTENSITIES MAY VARY WITH THICKNESS LEFT AFTER REWORK. REFER TO 51-20-06.



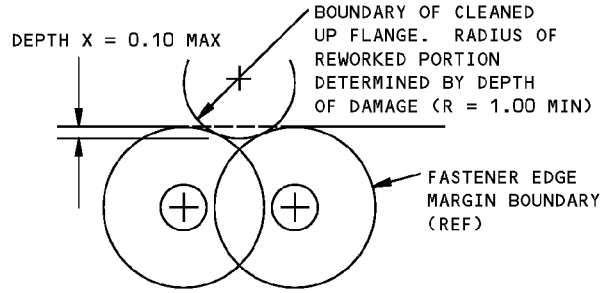
**REMOVAL OF NICK OR CRACK DAMAGE ON AN EDGE
DETAIL I**

**Sta 1180 Wheel Well Bulkhead Allowable Damage
Figure 101 (Sheet 2 of 3)**

STRUCTURAL REPAIR MANUAL

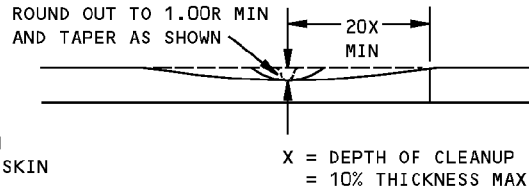
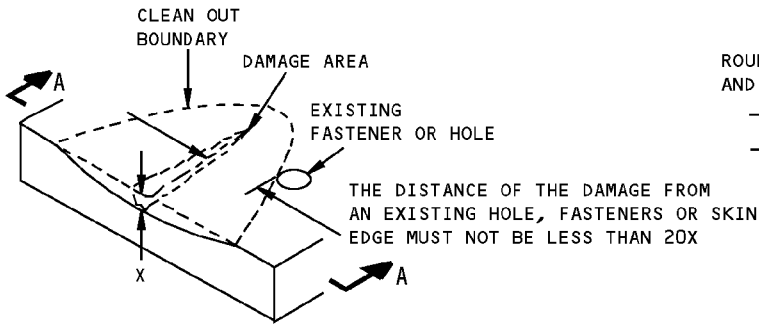


DAMAGE CLEANUP OF EDGES WHERE FASTENER EDGE MARGINS DO NOT OVERLAP



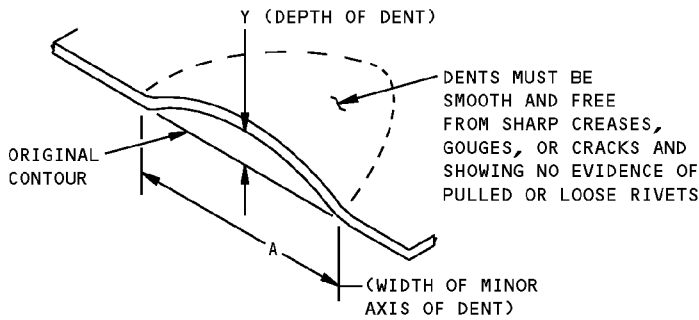
DAMAGE CLEANUP OF EDGES WHERE FASTENER EDGE MARGINS OVERLAP

DETAIL II



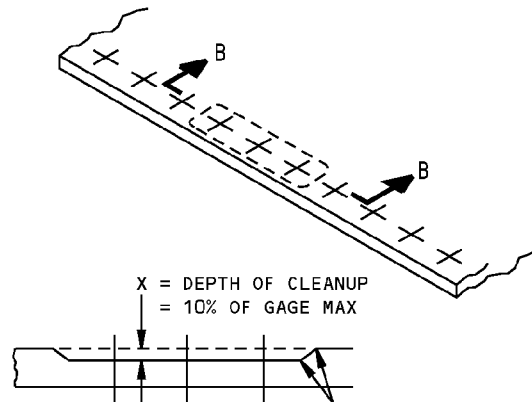
SECTION A-A

REMOVAL OF NICK, GOUGE AND SCRATCH DAMAGE ON A SURFACE
DETAIL III



$\frac{A}{Y}$ MUST NOT BE LESS THAN 30
Y = 0.125 MAX FOR WEBS

ALLOWABLE DAMAGE FOR DENT
DETAIL IV



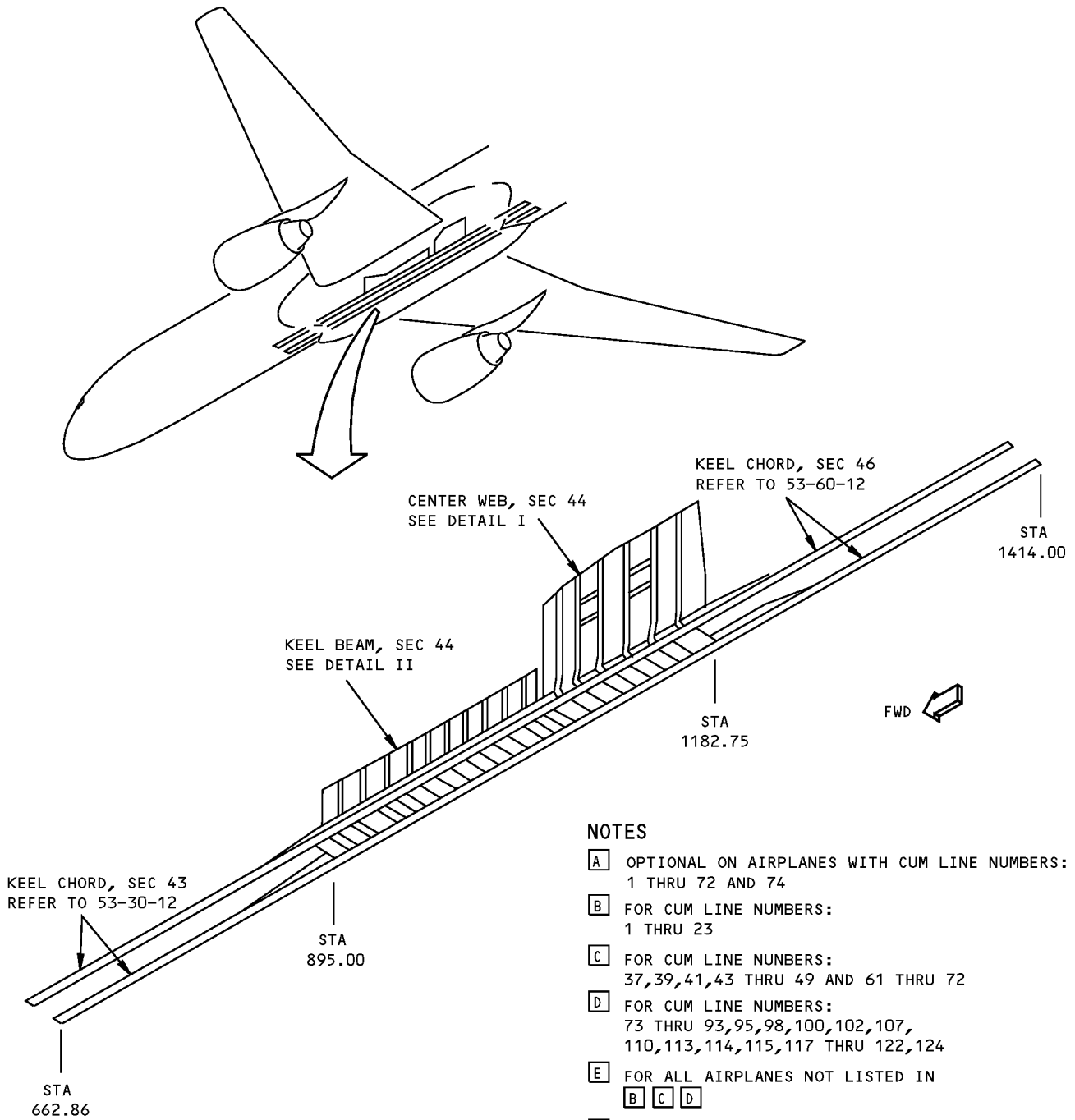
SMOOTH BLEND-OUT RADIUS 0.50 INCH MINIMUM. CORROSION CLEANUP AROUND ANY THREE FASTENERS IN TEN IS PERMITTED TO MAX DEPTH

SECTION B-B
CORROSION CLEANUP
DETAIL V

**Sta 1180 Wheel Well Bulkhead Allowable Damage
Figure 101 (Sheet 3 of 3)**

**757-200
STRUCTURAL REPAIR MANUAL**

IDENTIFICATION 1 - SECTION 44 - KEEL BEAM STRUCTURE



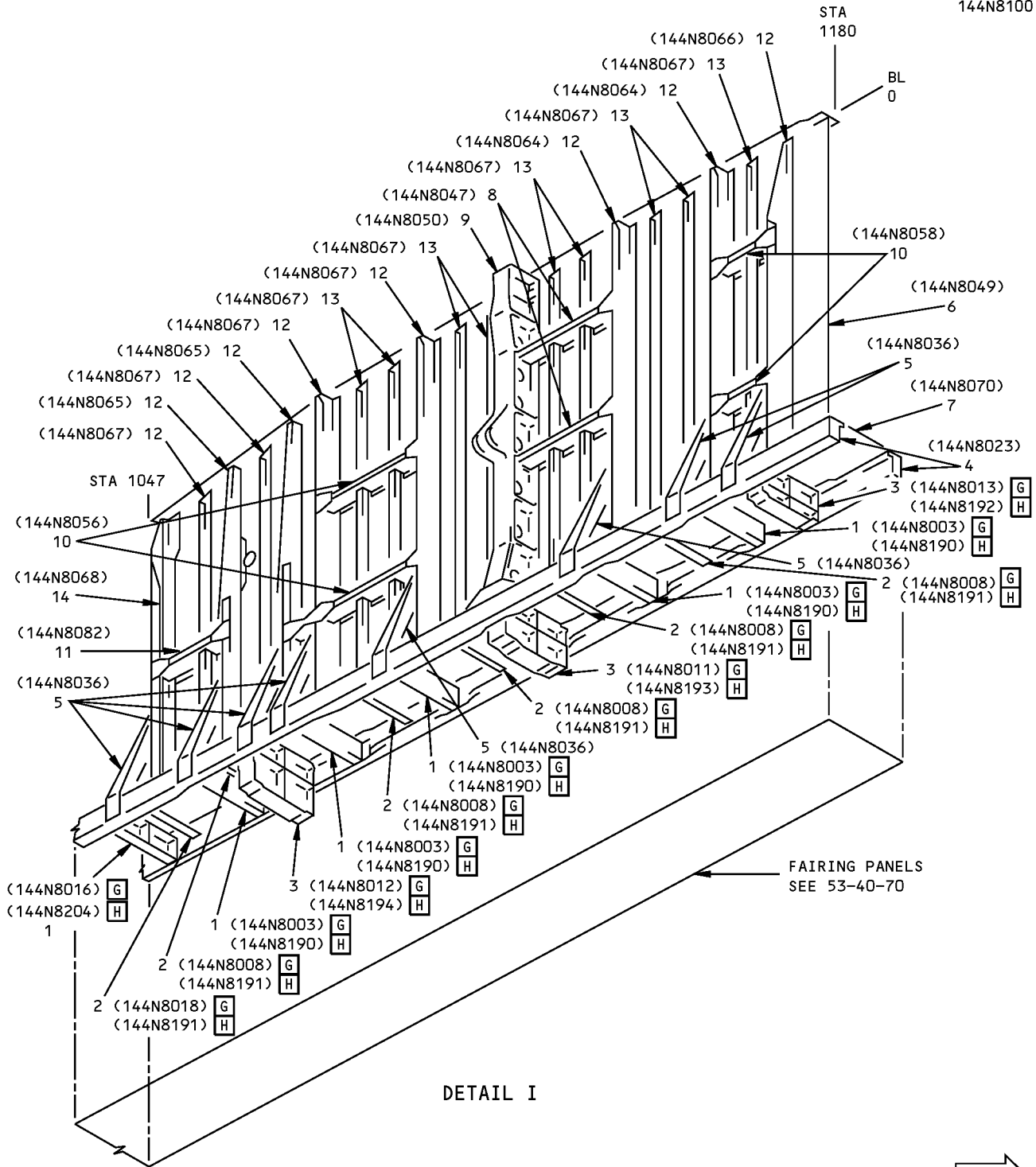
NOTES

- A** OPTIONAL ON AIRPLANES WITH CUM LINE NUMBERS:
1 THRU 72 AND 74
- B** FOR CUM LINE NUMBERS:
1 THRU 23
- C** FOR CUM LINE NUMBERS:
37,39,41,43 THRU 49 AND 61 THRU 72
- D** FOR CUM LINE NUMBERS:
73 THRU 93,95,98,100,102,107,
110,113,114,115,117 THRU 122,124
- E** FOR ALL AIRPLANES NOT LISTED IN
B C D
- F** FOR CUM LINE NUMBERS:
1 THRU 341
- G** FOR CUM LINE NUMBERS:
342 THRU 803
- H** FOR CUM LINE NUMBERS:
804 AND ON

**Section 44 Keel Beam Structure Identification
Figure 1 (Sheet 1 of 4)**

**757-200
STRUCTURAL REPAIR MANUAL**

REF DWG
144N8100



**Section 44 Keel Beam Structure Identification
Figure 1 (Sheet 2 of 4)**

IDENTIFICATION 1
Page 2
May 20/2005

53-40-12

D634N201



**757-200
STRUCTURAL REPAIR MANUAL**

ITEM	DESCRIPTION	GAGE	MATERIAL	
1	FITTING		FORGING 7075-T73 PLATE 7050-T7451 AS GIVEN IN AMS 4050	G H
2	STIFFENER		FORGING 7075-T73 PLATE 7050-T7451 AS GIVEN IN AMS 4050	G H
3	SUPPORT		FORGING 7075-T73	
4	CHORD		BAC1520-2208 7150-T6511 BAC1520-2208 7150-T77511 BAC1520-2208 7035-T77511	F G H
5	BRACE		FORGING 7075-T73 BAC1506-3397 7075-T6	A
6	WEB	0.180	2024-T3	
7	HORIZONTAL WEB	0.080	2024-T3	
8	HORIZONTAL INTER-COSTAL		FORGING 7075-T73 BAC1510-1077 7075-T6511	A
9	ACTUATOR FITTING		FORGED BLOCK 7050-T73652 FORGING 7175-T736 FORGING X7090-T7E71 FORGING 7075-T73	B C D E
10	STIFFENER	0.063	2024-T3	
11	STIFFENER		BAC1514-2617 7075-T73511	
12	STIFFENER		BAC1506-3344 7075-T6511	
13	STIFFENER		BAC1517-2195 7075-T6511	
14	STIFFENER		BAC1506-3345 7075-T6511	

LIST OF MATERIALS FOR DETAIL I

**Section 44 Keel Beam Structure Identification
Figure 1 (Sheet 3 of 4)**

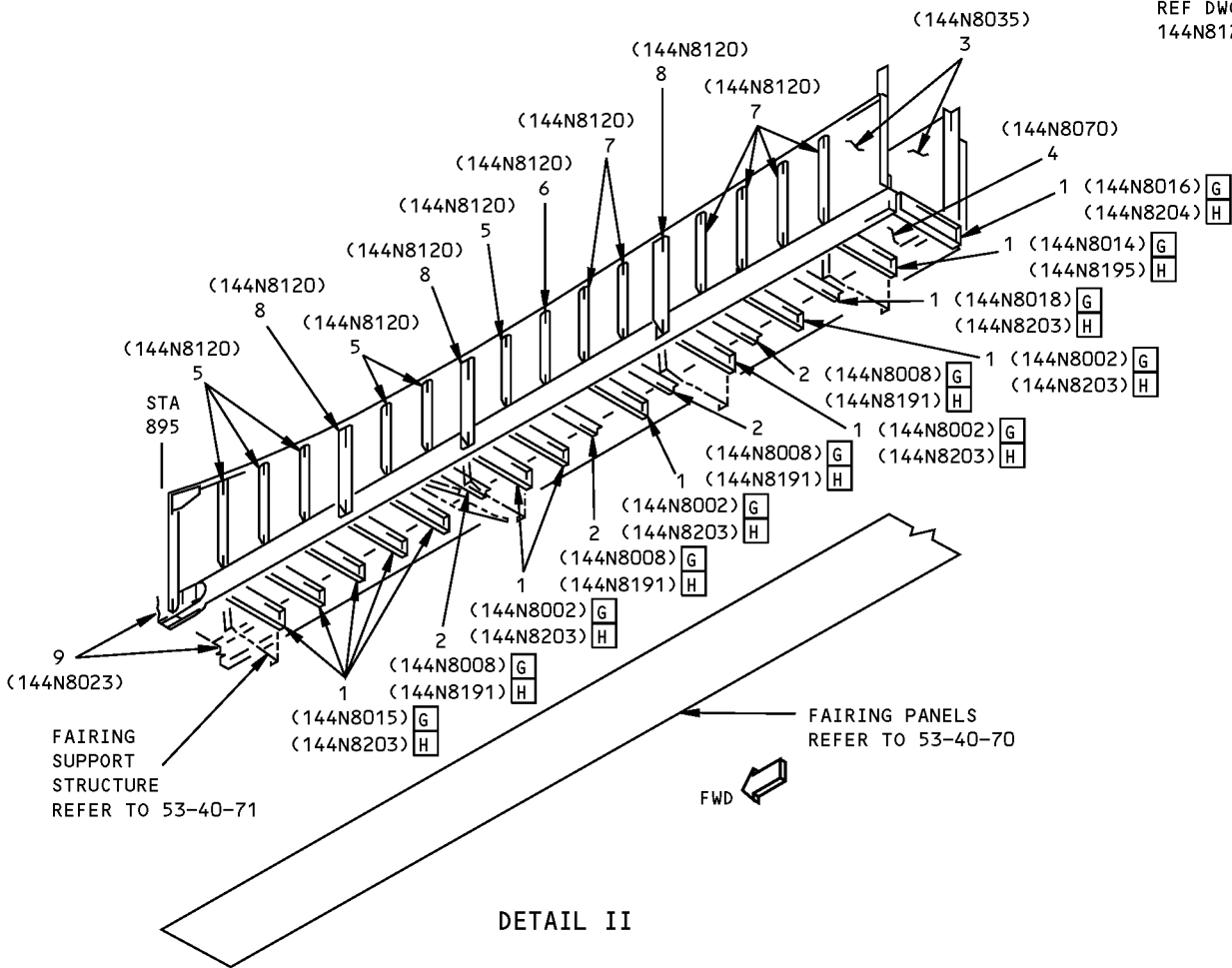
IDENTIFICATION 1
Page 3
May 20/2005

53-40-12

D634N201

**757-200
STRUCTURAL REPAIR MANUAL**

REF DWG
144N8120



ITEM	DESCRIPTION	GAGE	MATERIAL	EFFECTIVITY			
1	FITTING		FORGING 7075-T73 PLATE 7050-T7451 AS GIVEN IN AMS 4050	<table border="1"><tr><td>G</td></tr><tr><td>H</td></tr></table>	G	H	
G							
H							
2	STIFFENER		FORGING 7075-T73 PLATE 7050-T7451 AS GIVEN IN AMS 4050	<table border="1"><tr><td>G</td></tr><tr><td>H</td></tr></table>	G	H	
G							
H							
3	WEB	0.150	2024-T3				
4	HORIZONTAL WEB	0.080	2024-T3				
5	STIFFENER		AND10133-1202 7075-T6511				
6	STIFFENER		AND10133-1203 7075-T6511				
7	STIFFENER		AND10134-2005 7075-T6511				
8	STIFFENER		AND10136-3002 7075-T6511				
9	CHORD		BAC1520-2208 7150-T6511 BAC1520-2208 7150-T77511 BAC1520-2208 7055-T77511	<table border="1"><tr><td>F</td></tr><tr><td>G</td></tr><tr><td>H</td></tr></table>	F	G	H
F							
G							
H							

LIST OF MATERIALS FOR DETAIL II

**Section 44 Keel Beam Structure Identification
Figure 1 (Sheet 4 of 4)**

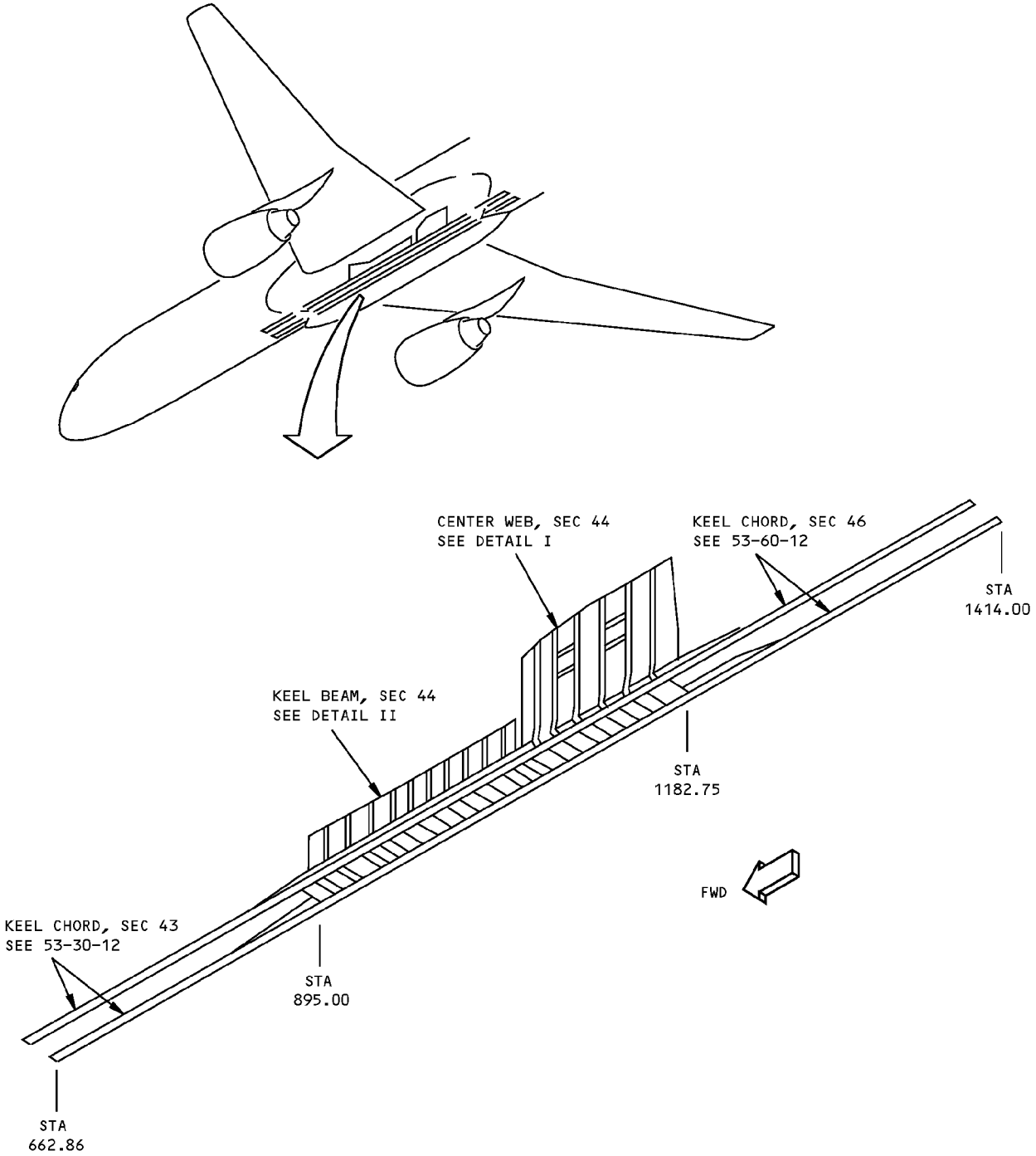
IDENTIFICATION 1
Page 4
May 20/2005

53-40-12

D634N201

**757-200
STRUCTURAL REPAIR MANUAL**

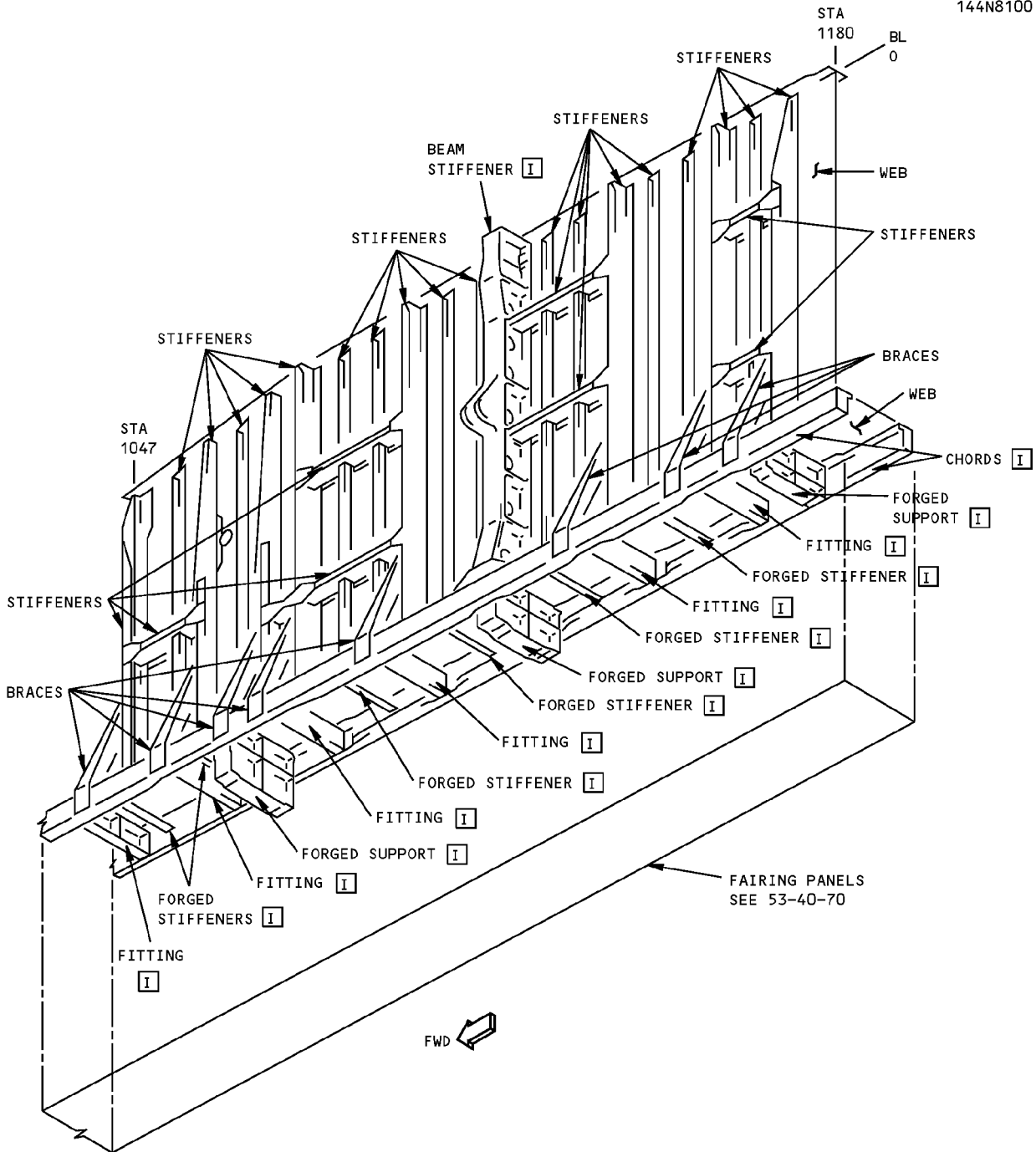
ALLOWABLE DAMAGE 1 - SECTION 44 - KEEL BEAM STRUCTURE



**Section 44 - Keel Beam Structure Allowable Damage
Figure 101 (Sheet 1 of 7)**

**757-200
STRUCTURAL REPAIR MANUAL**

REF DWG
144N8100



MATERIAL: ALUMINUM

DETAIL I

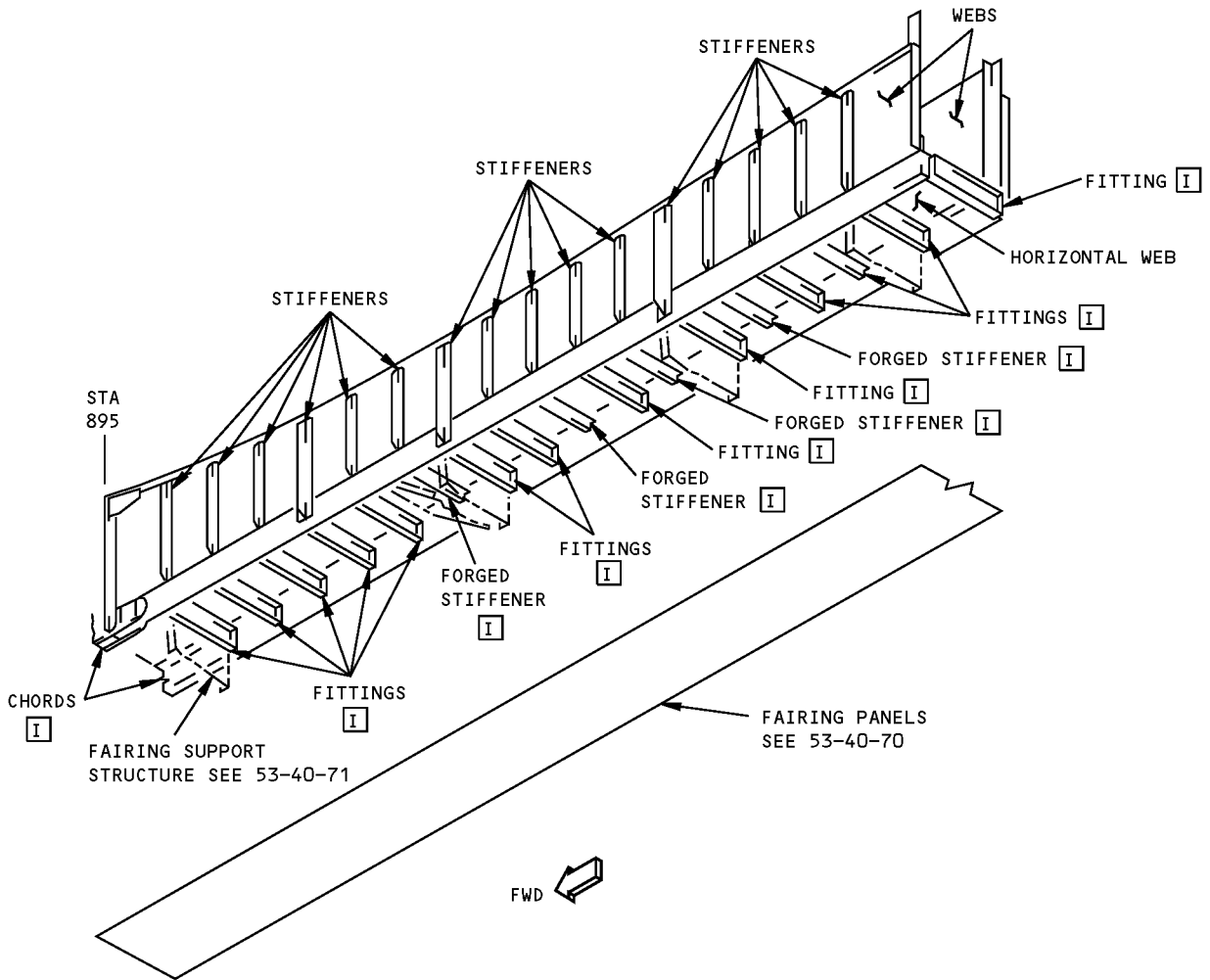
**Section 44 - Keel Beam Structure Allowable Damage
Figure 101 (Sheet 2 of 7)**

D634N201

ALLOWABLE DAMAGE 1
53-40-12
Page 102
Jan 20/2005

**757-200
STRUCTURAL REPAIR MANUAL**

REF DWG
144N8120



MATERIAL: ALUMINUM

DETAIL II

**Section 44 - Keel Beam Structure Allowable Damage
Figure 101 (Sheet 3 of 7)**

D634N201

ALLOWABLE DAMAGE 1
53-40-12
Page 103
Jan 20/2005



757-200

STRUCTURAL REPAIR MANUAL

DESCRIPTION	CRACKS	NICKS, GOUGES AND CORROSION	DENTS	HOLES AND PUNCTURES
FITTINGS	A	B	NOT ALLOWED	NOT ALLOWED
CHORDS	C	B	NOT ALLOWED	NOT ALLOWED
WEBS	D	F	SEE DETAIL V	E
FORGED STIFFENERS	A	B	NOT ALLOWED	NOT ALLOWED
FORGED SUPPORTS	A	B	NOT ALLOWED	NOT ALLOWED
BRACES	G	F	NOT ALLOWED	E
STIFFENERS	G	F	NOT ALLOWED	SEE DETAIL IX
BEAM STIFFENER	C	H	NOT ALLOWED	NOT ALLOWED

NOTES

- REFINISH REWORKED AREAS PER 51-20 OF THE MAINTENANCE MANUAL
- A CRACKS NOT ALLOWED EXCEPT FOR EDGE CRACKS WHICH MUST BE REMOVED PER DETAIL XI. SEE DETAILS I, II FOR APPLICABLE SHOT PEEN REQUIREMENTS
 - B REMOVE DAMAGE PER DETAILS IV, VIII AND XI. SEE DETAILS I, II FOR APPLICABLE SHOT PEEN REQUIREMENTS
 - C CRACKS NOT ALLOWED EXCEPT FOR EDGE CRACKS WHICH MUST BE REMOVED PER DETAILS III AND VIII. SEE DETAILS I, II FOR APPLICABLE SHOT PEEN REQUIREMENTS
 - D CRACKS NOT ALLOWED EXCEPT FOR EDGE CRACKS WHICH MUST BE REMOVED PER DETAILS III AND VII
 - E CLEAN OUT DAMAGE UP TO 0.25 MAX DIA AND NOT CLOSER THAN 1.0 INCH TO FASTENER HOLE OR OTHER DAMAGE. MAINTAIN 2.0D EDGE MARGIN ON PART EDGE. FILL HOLE WITH A 2117-T3 OR T4 ALUMINUM RIVET INSTALLED WET WITH BMS 5-95 SEALANT. ALL OTHER HOLES TO BE REPAIRED
 - F REMOVE DAMAGE PER DETAILS III, IV, AND VI
 - G CRACKS NOT ALLOWED EXCEPT FOR EDGE CRACKS WHICH MUST BE REMOVED PER DETAILS III AND VIII
 - H FOR EDGE DAMAGE SEE DETAIL XI. FOR LUG DAMAGE SEE DETAIL X. FOR OTHER DAMAGE SEE DETAIL IV. DAMAGE NOT ALLOWED IN VICINITY OF BUSHINGS. SEE DETAIL I FOR APPLICABLE SHOT PEEN REQUIREMENTS
 - I SHOT PEEN REWORKED AREA PER 51-20-06

Section 44 - Keel Beam Structure Allowable Damage
Figure 101 (Sheet 4 of 7)

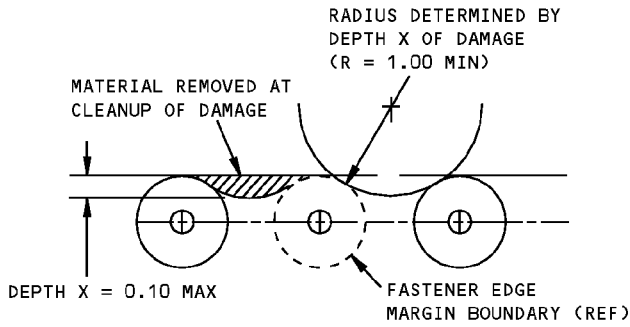
ALLOWABLE DAMAGE 1

53-40-12

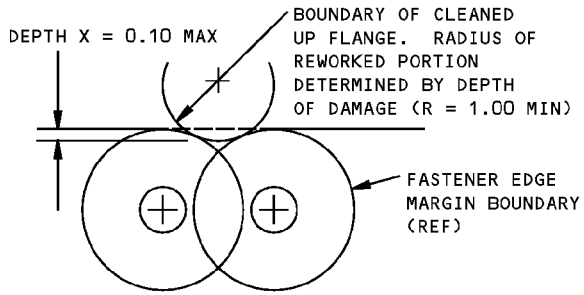
Page 104
Jan 20/2005

D634N201

STRUCTURAL REPAIR MANUAL

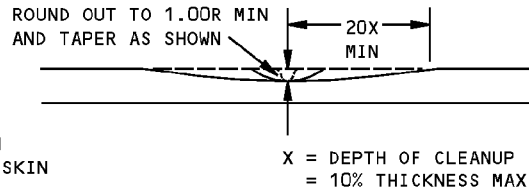
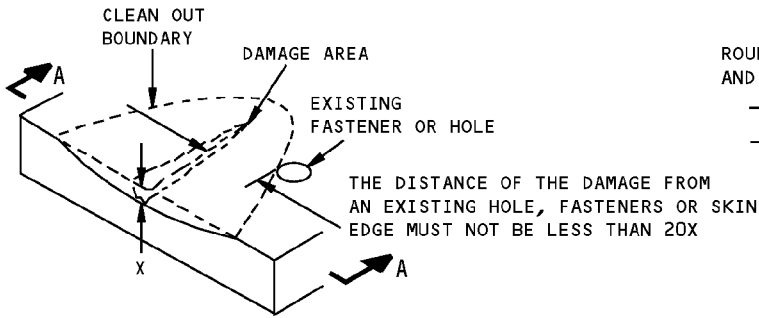


DAMAGE CLEANUP OF EDGES WHERE FASTENER EDGE MARGINS DO NOT OVERLAP



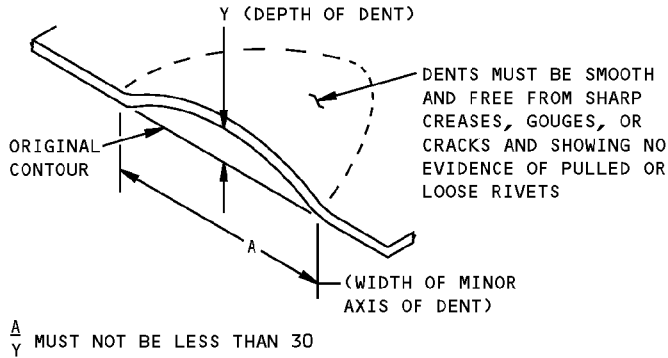
DAMAGE CLEANUP OF EDGES WHERE FASTENER EDGE MARGINS OVERLAP

DETAIL III

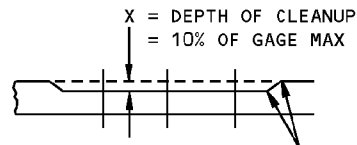
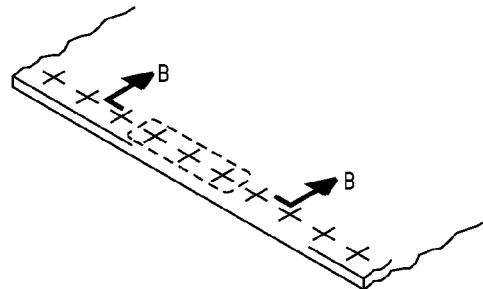


SECTION A-A

REMOVAL OF NICK, GOUGE AND SCRATCH DAMAGE ON A SURFACE
DETAIL IV



ALLOWABLE DAMAGE FOR DENT
DETAIL V

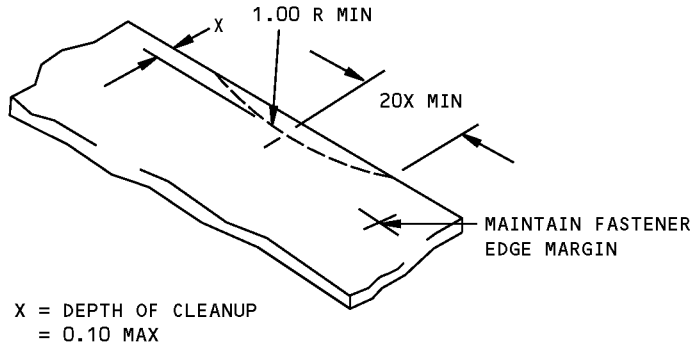


SMOOTH BLEND-OUT RADIUS 0.50 INCH MINIMUM. CORROSION CLEANUP AROUND ANY THREE FASTENERS IN TEN IS PERMITTED TO MAX DEPTH

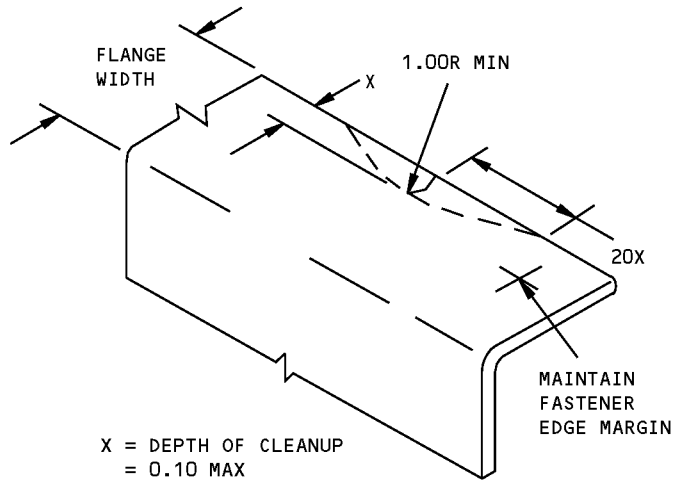
SECTION B-B
CORROSION CLEANUP
DETAIL VI

**Section 44 - Keel Beam Structure Allowable Damage
Figure 101 (Sheet 5 of 7)**

757-200
STRUCTURAL REPAIR MANUAL



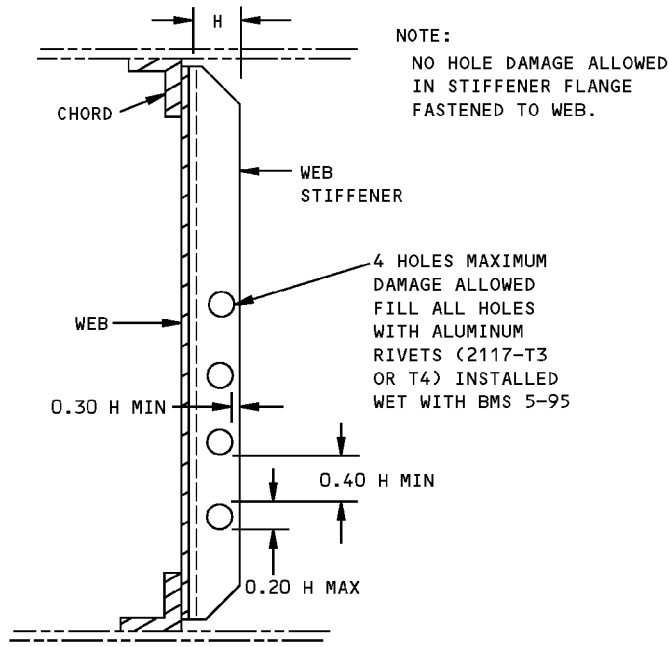
**REMOVAL OF NICK OR CRACK
DAMAGE ON AN EDGE
DETAIL VII**



**REMOVAL OF NICK OR CRACK
DAMAGE ON AN EDGE
DETAIL VIII**

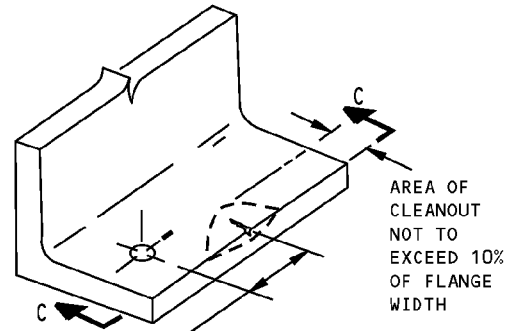
Section 44 - Keel Beam Structure Allowable Damage
Figure 101 (Sheet 6 of 7)

**757-200
STRUCTURAL REPAIR MANUAL**

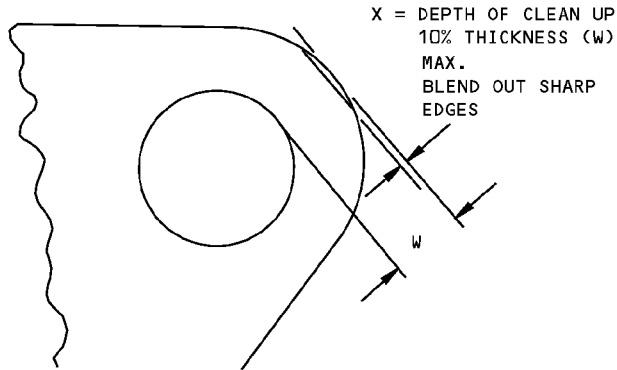


H = WIDTH OF STIFFENER FLANGE

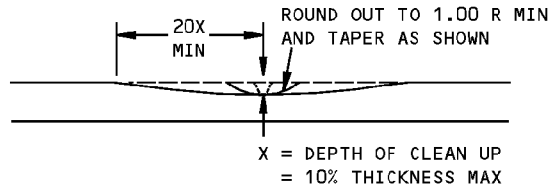
**ALLOWABLE DAMAGE LIMITS FOR HOLES IN WEB STIFFENERS
DETAIL IX**



THE DISTANCE OF THE DAMAGE FROM AN EXISTING HOLE, FASTENERS OR EDGE MUST NOT BE LESS THAN 20X



**DAMAGE CLEAN UP FOR EDGES OF LUG
DETAIL X**

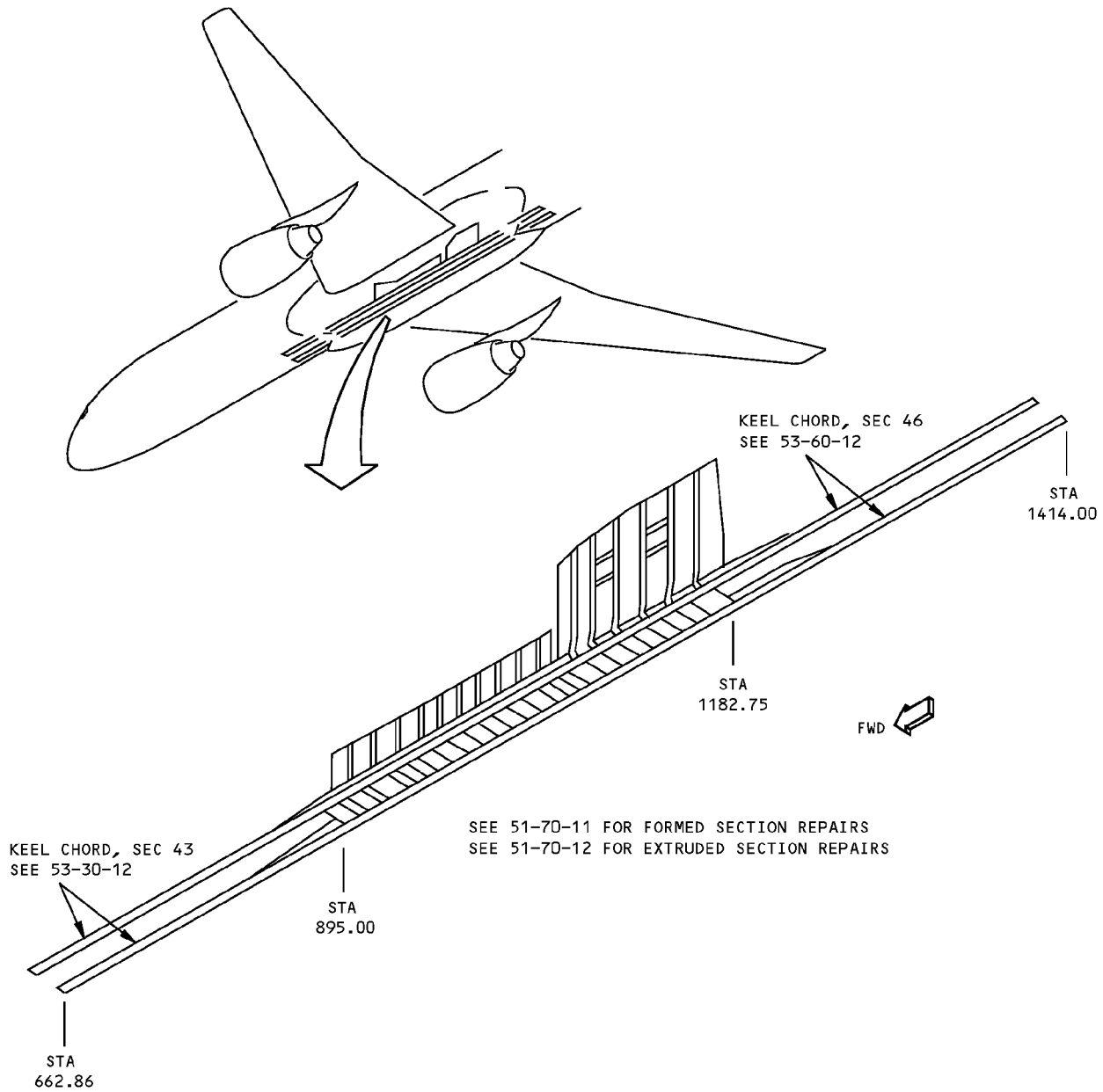


**SECTION C-C
REMOVAL OF NICK OR CRACK
DAMAGE ON AN EDGE
DETAIL XI**

**Section 44 - Keel Beam Structure Allowable Damage
Figure 101 (Sheet 7 of 7)**

**757-200
STRUCTURAL REPAIR MANUAL**

REPAIR GENERAL - SECTION 44 - KEEL BEAM STRUCTURE



NOTES

- WEB REPAIR IN 51-70-13 DOES NOT APPLY TO KEEL BEAM WEBS
- REPAIRS NOT ALLOWED TO FORGINGS

**Section 44 Keel Beam Structure Repair
Figure 201**

D634N201

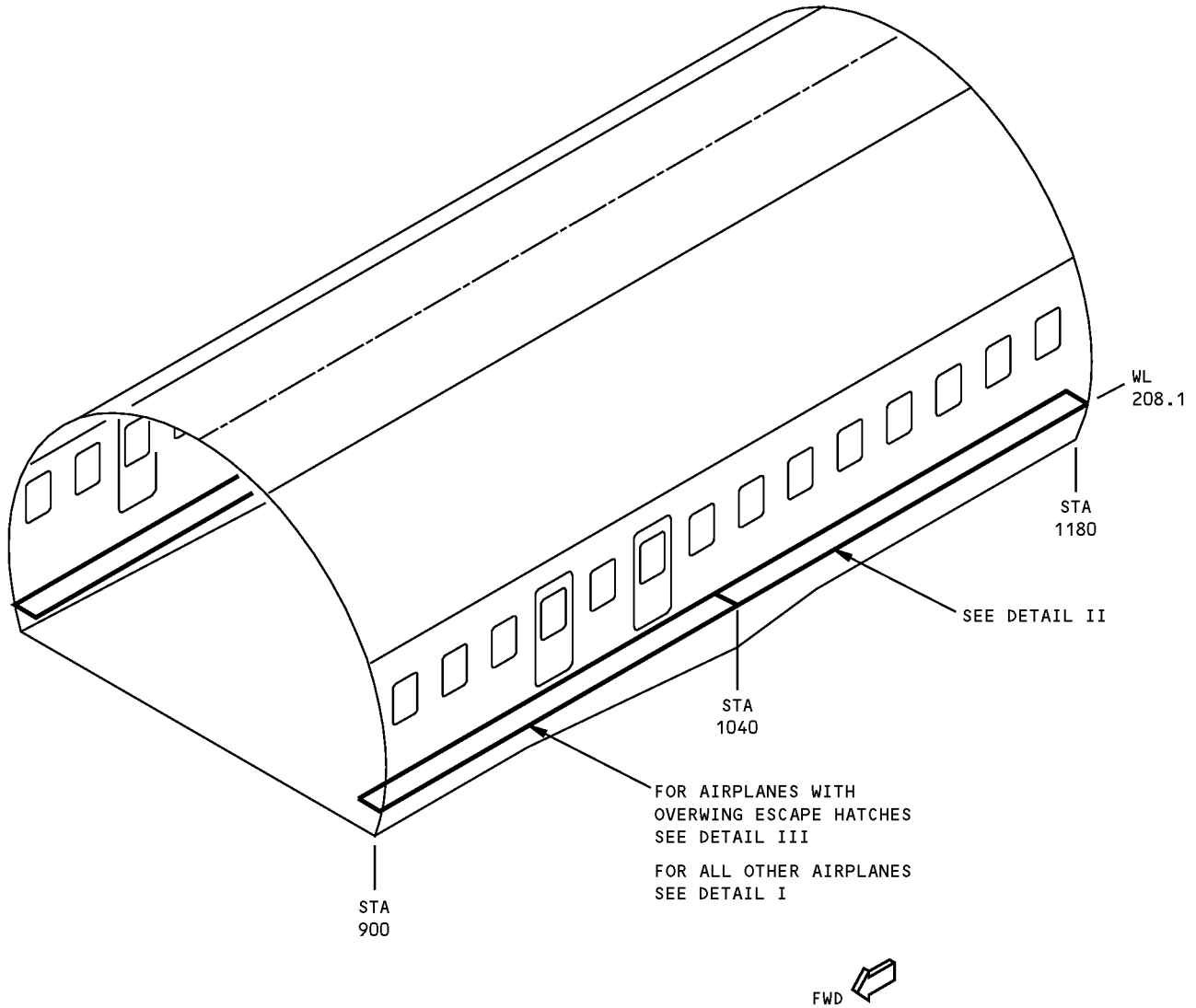
53-40-12

REPAIR GENERAL
Page 201
Jan 20/2005



757-200
STRUCTURAL REPAIR MANUAL

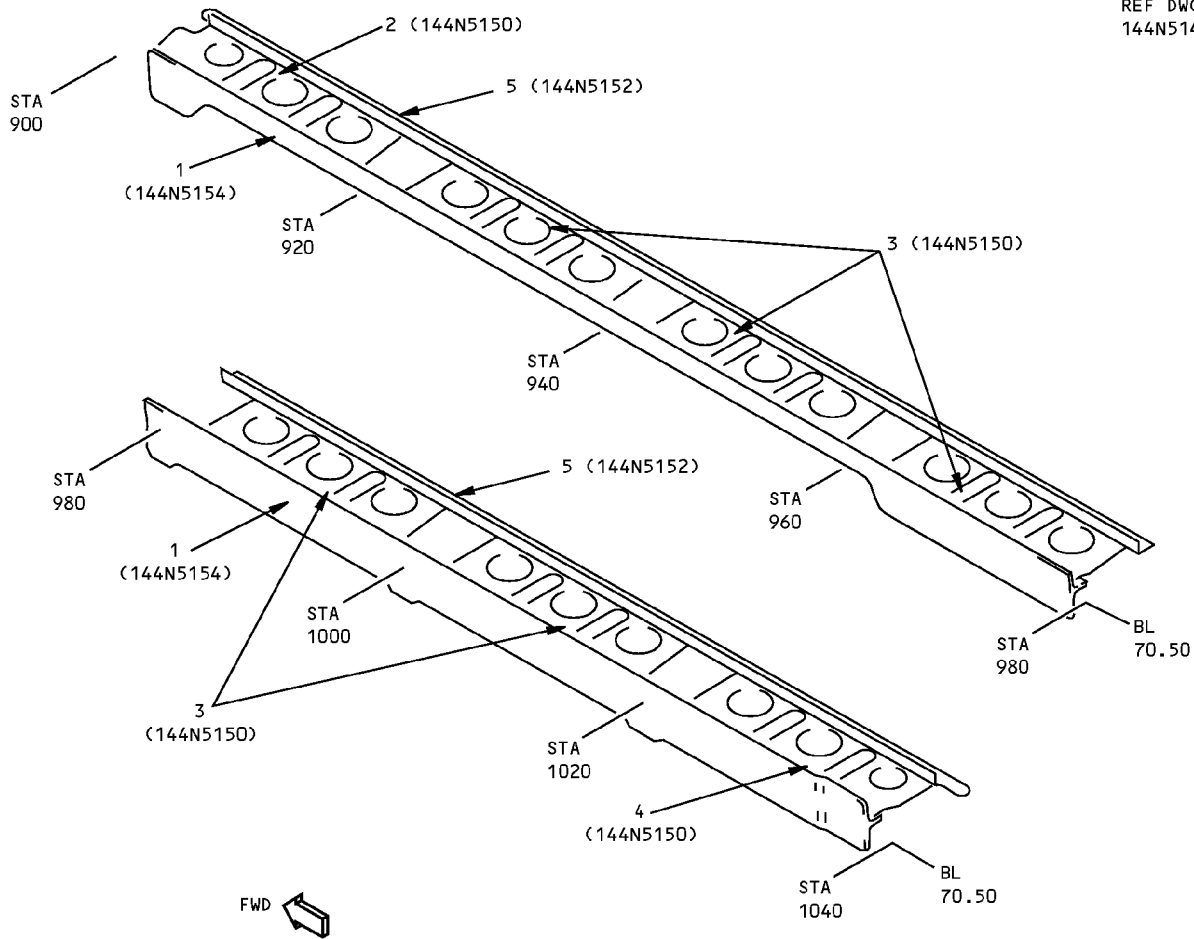
IDENTIFICATION 1 - SECTION 44 - CREASE BEAM



Section 44 Crease Beam Identification
Figure 1 (Sheet 1 of 4)

**757-200
STRUCTURAL REPAIR MANUAL**

REF DWG
144N5140



LEFT SIDE SHOWN
RIGHT SIDE OPPOSITE
DETAIL I

ITEM	DESCRIPTION	GAGE	MATERIAL	EFFECTIVITY
1	OUTER CHORD		BAC1506-3284 7075-T73511	
2	WEB	0.050	7075-T6	
3	WEB	0.056	7075-T6	
4	WEB	0.063	7075-T6	
5	INNER CHORD		BAC1515-551 7075-T73511	

LIST OF MATERIALS FOR DETAIL I

**Section 44 Crease Beam Identification
Figure 1 (Sheet 2 of 4)**

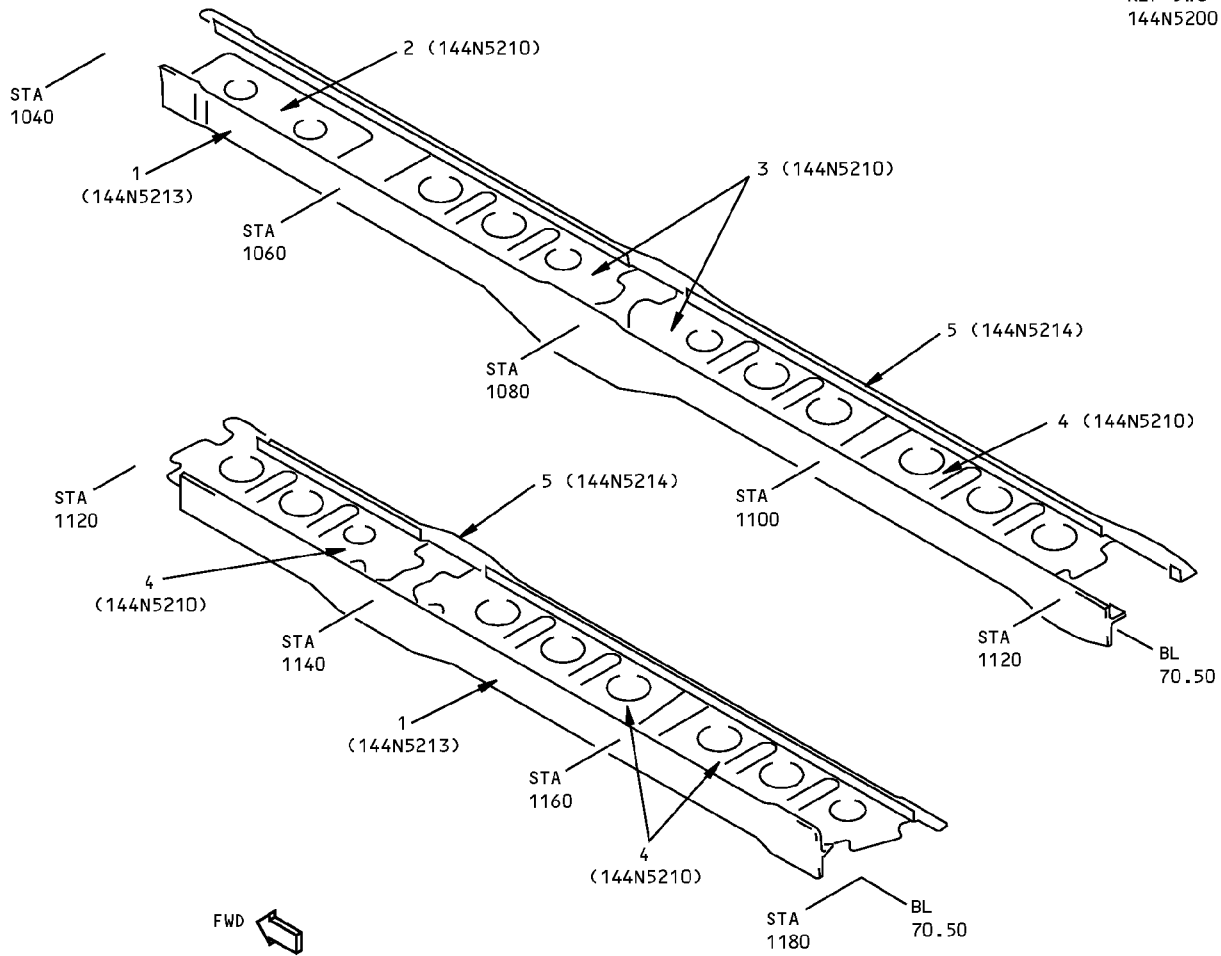
IDENTIFICATION 1
Page 2
Jan 20/2005

53-40-13

D634N201

**757-200
STRUCTURAL REPAIR MANUAL**

REF DWG
144N5200



LEFT SIDE SHOWN
RIGHT SIDE OPPOSITE
DETAIL II

ITEM	DESCRIPTION	GAGE	MATERIAL	EFFECTIVITY
1	OUTER CHORD		BAC1506-3284 7075-T73511	
2	WEB	0.080	7075-T6	
3	WEB	0.071	7075-T6	
4	WEB	0.063	7075-T6	
5	INNER CHORD		BAC1515-553 7075-T6511	

LIST OF MATERIALS FOR DETAIL II

**Section 44 Crease Beam Identification
Figure 1 (Sheet 3 of 4)**

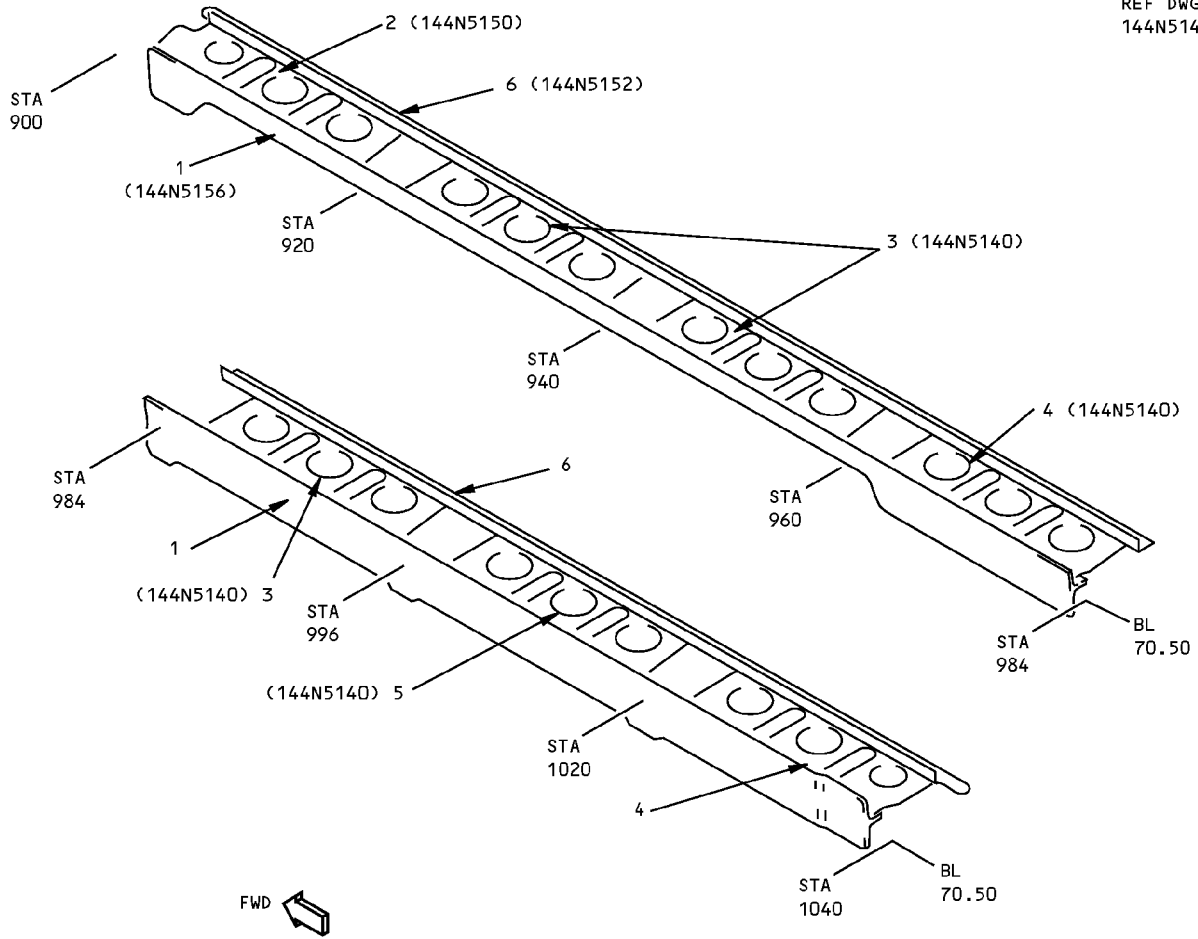
IDENTIFICATION 1
Page 3
Jan 20/2005

53-40-13

D634N201

**757-200
STRUCTURAL REPAIR MANUAL**

REF DWG
144N5140



AIRPLANES WITH OVERWING ESCAPE HATCHES
LEFT SIDE SHOWN
RIGHT SIDE OPPOSITE
DETAIL III

ITEM	DESCRIPTION	GAGE	MATERIAL	EFFECTIVITY
1	OUTER CHORD		BAC1506-3504 7075-T73511	
2	WEB	0.050	7075-T6	
3	WEB	0.056	7075-T6	
4	WEB	0.063	7075-T6	
5	WEB	0.071	7075-T6	
6	INNER CHORD		BAC1515-551 7075-T73511	

LIST OF MATERIALS FOR DETAIL III

**Section 44 Crease Beam Identification
Figure 1 (Sheet 4 of 4)**

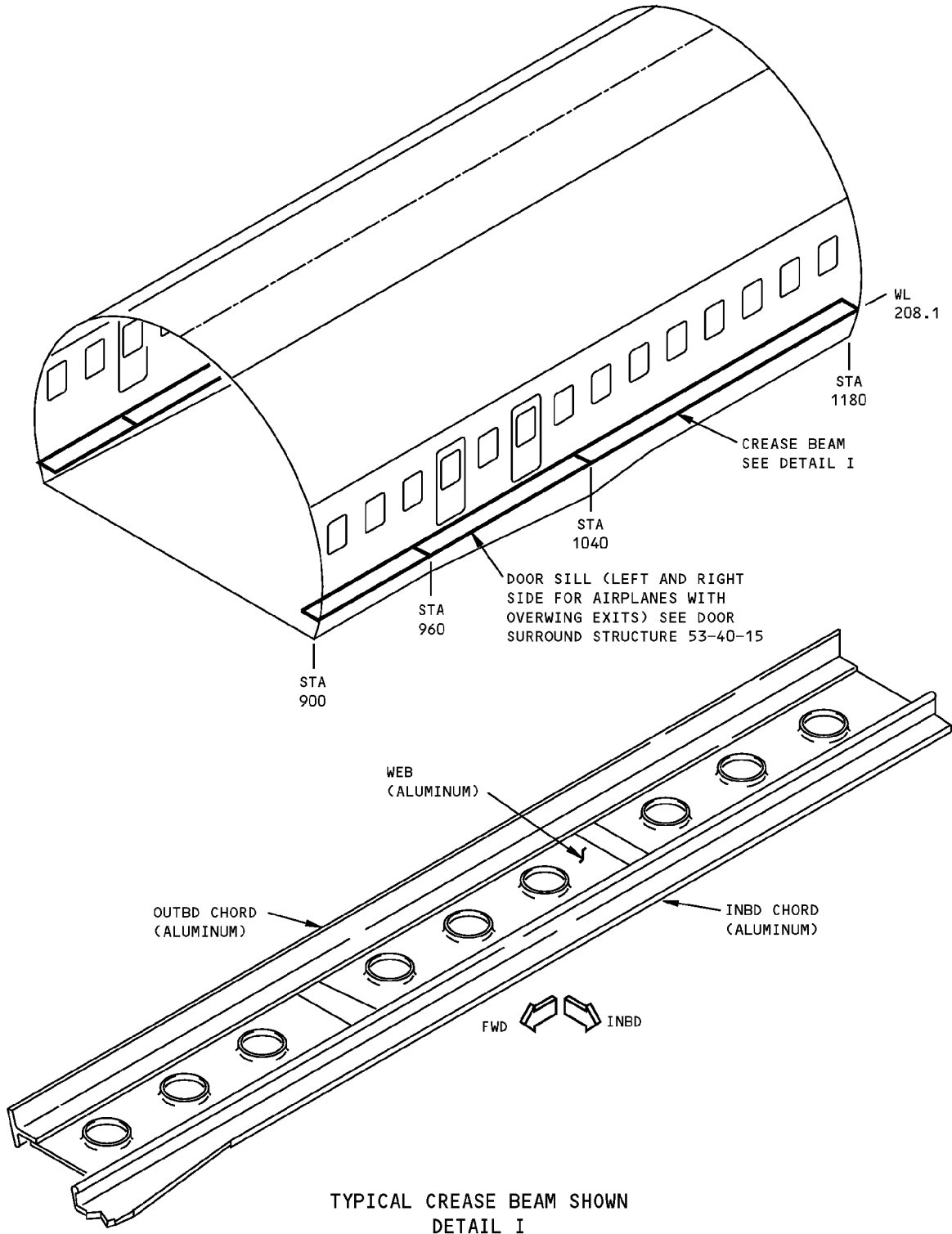
IDENTIFICATION 1
Page 4
Jan 20/2005

53-40-13

D634N201

**757-200
STRUCTURAL REPAIR MANUAL**

ALLOWABLE DAMAGE 1 - SECTION 44 - CREASE BEAM



**Section 44 Crease Beam Allowable Damage
Figure 101 (Sheet 1 of 4)**



757-200
STRUCTURAL REPAIR MANUAL

DESCRIPTION	CRACKS	NICKS, GOUGES AND CORROSION	DENTS	HOLES AND PUNCTURES
WEBS - FLANGED HOLE	[A]	[B]	SEE DETAIL IV	[C]
CHORD - INBD	[F]	SEE DETAIL VII	NOT PERMITTED	NOT PERMITTED
CHORD - OUTBD	[D]	[E]	NOT PERMITTED	NOT PERMITTED

NOTES

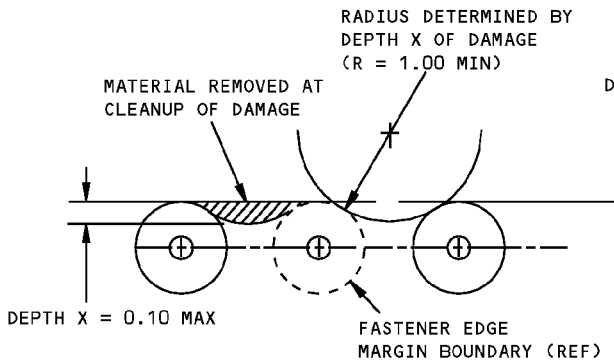
- REFINISH REWORKED AREAS AS GIVEN IN AMM 51-20
- REFER TO SRM 51-10-02 FOR INSPECTION AND REMOVAL OF DAMAGE

- [A] FOR EDGE CRACKS SEE DETAILS II AND V. FOR LIGHTENING HOLE EDGE CRACKS SEE DETAIL VI
- [B] REMOVE DAMAGE AS SHOWN IN DETAILS III, V, AND VI
- [C] CLEAN OUT DAMAGE UP TO 0.25 INCH (6 mm) MAX DIA AND NOT CLOSER THAN 1.5 INCHES (38 mm) TO FASTENER HOLE, MATERIAL EDGE, OR OTHER DAMAGE. FILL HOLE WITH 2117-T3 OR T4 ALUMINUM RIVET INSTALLED WET WITH BMS 5-95 SEALANT. ALL OTHER HOLES TO BE REPAIRED

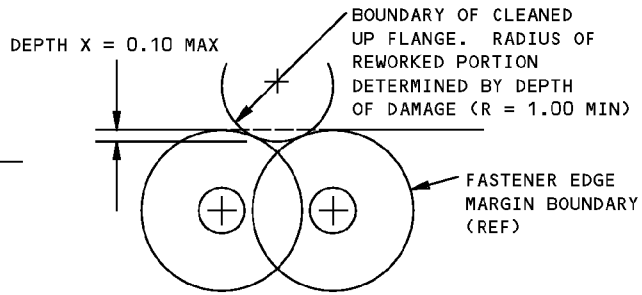
- [D] CRACKS ARE NOT PERMITTED EXCEPT FOR EDGE CRACKS WHICH MUST BE REMOVED AS SHOWN IN DETAILS II AND III
- [E] REMOVE EDGE DAMAGE AS SHOWN IN DETAILS II AND III
- [F] CRACKS ARE NOT PERMITTED EXCEPT FOR EDGE CRACKS WHICH MAY BE REMOVED AS SHOWN IN DETAILS II AND VII

Section 44 Crease Beam Allowable Damage
Figure 101 (Sheet 2 of 4)

**757-200
STRUCTURAL REPAIR MANUAL**

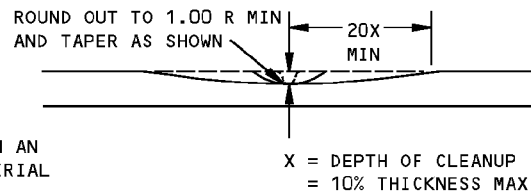
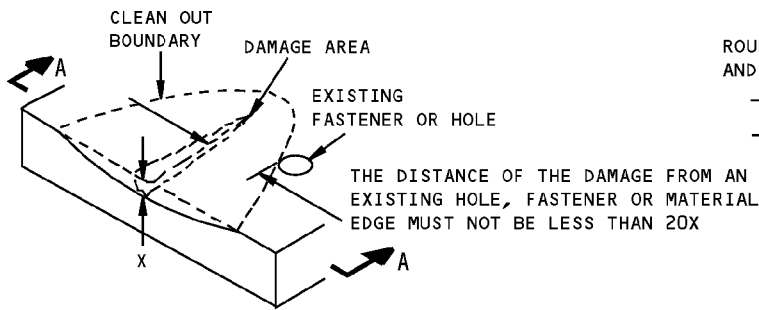


DAMAGE CLEANUP OF EDGES WHERE FASTENER EDGE MARGINS DO NOT OVERLAP



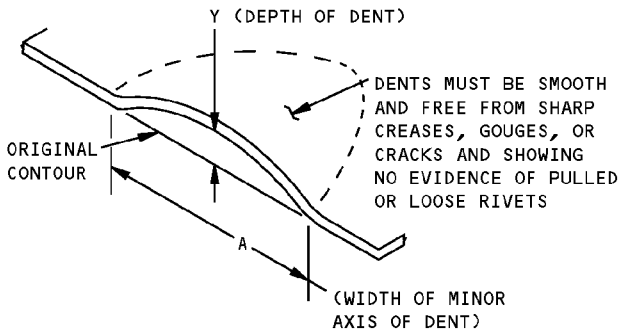
DAMAGE CLEANUP OF EDGES WHERE FASTENER EDGE MARGINS OVERLAP

DETAIL II



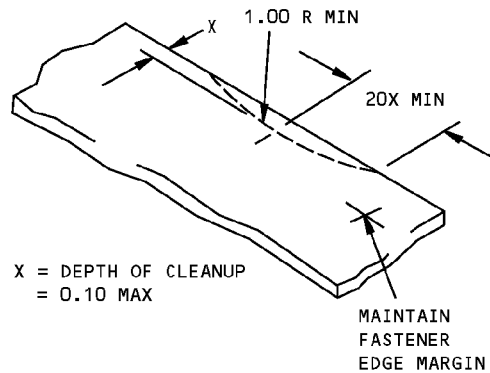
SECTION A-A

**REMOVAL OF NICK, GOUGE AND SCRATCH DAMAGE ON A SURFACE
DETAIL III**



$\frac{A}{Y}$ MUST NOT BE LESS THAN 30
Y (MAX) = 0.125

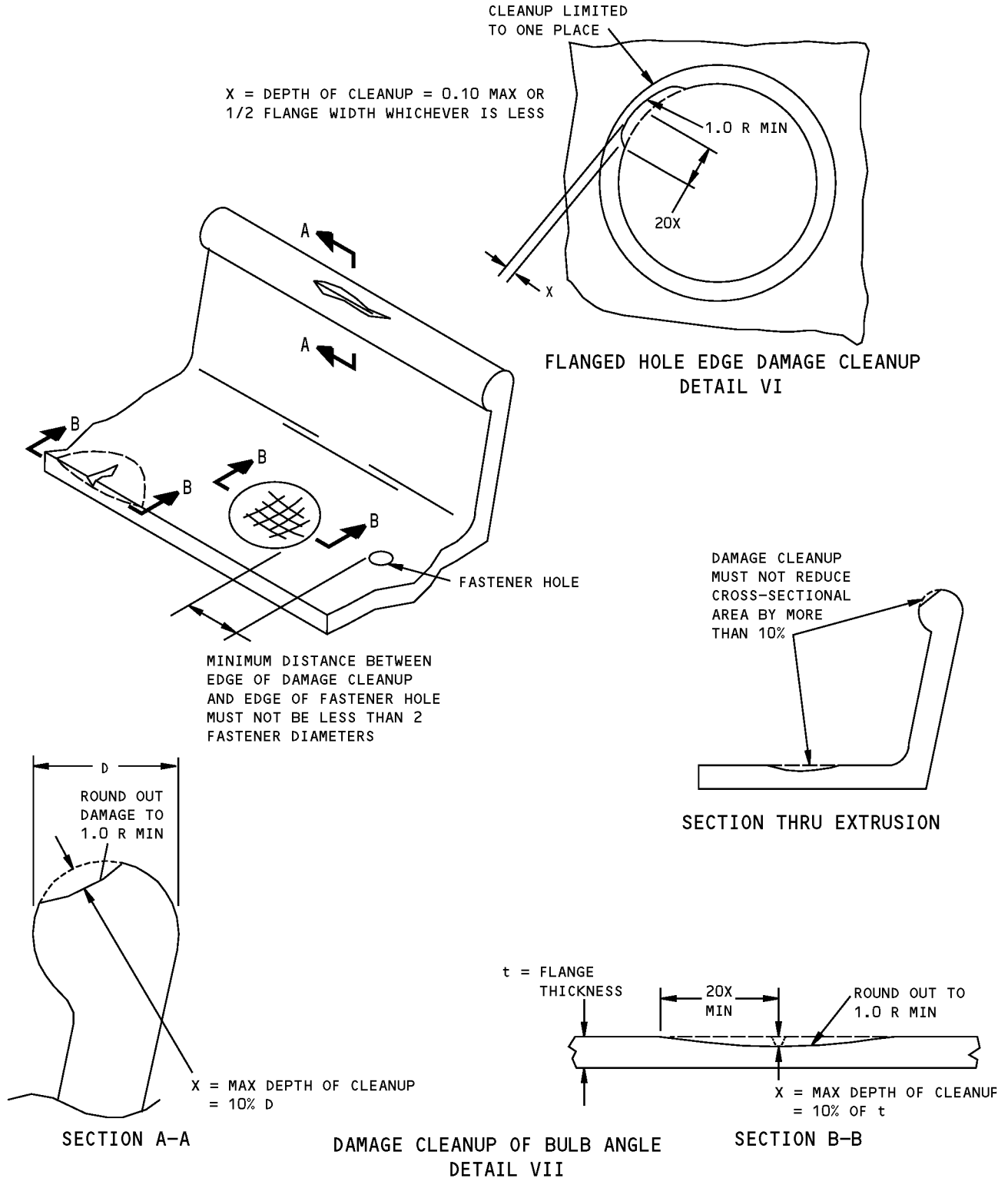
**ALLOWABLE DAMAGE FOR DENT
DETAIL IV**



**REMOVAL OF NICK OR CRACK
DAMAGE ON AN EDGE
DETAIL V**

**Section 44 Crease Beam Allowable Damage
Figure 101 (Sheet 3 of 4)**

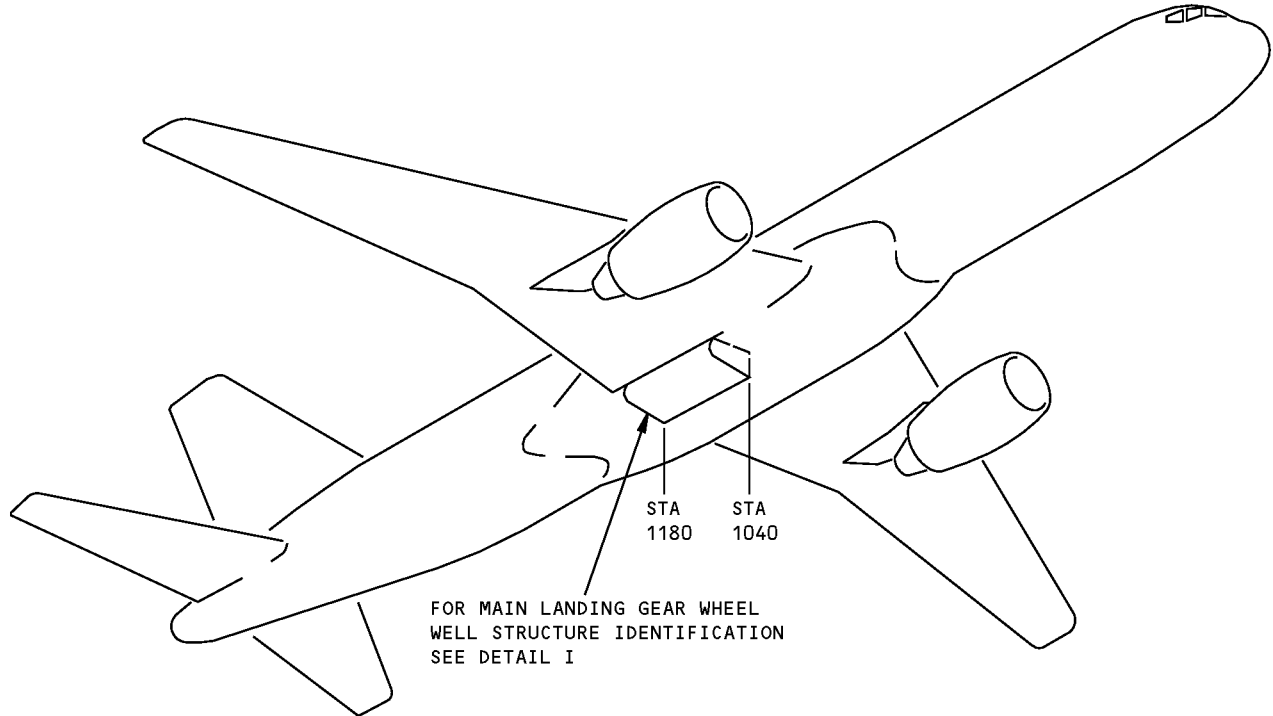
**757-200
STRUCTURAL REPAIR MANUAL**



**Section 44 Crease Beam Allowable Damage
Figure 101 (Sheet 4 of 4)**

757-200
STRUCTURAL REPAIR MANUAL

IDENTIFICATION 1 - SECTION 44 - MAIN LANDING GEAR WHEEL WELL STRUCTURE



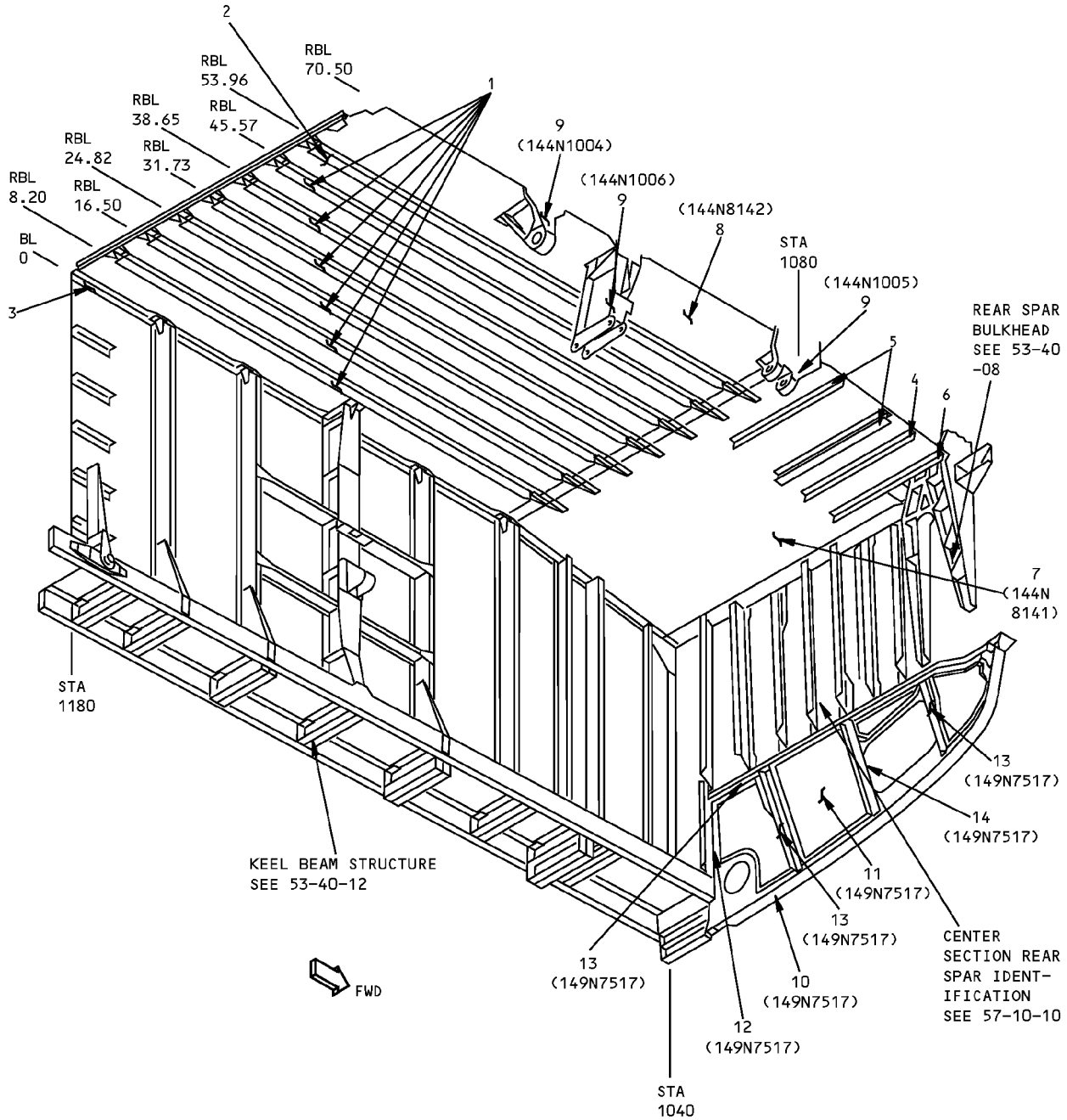
NOTES

- A** FOR CUM LINE NUMBERS 1 THRU 46
- B** FOR CUM LINE NUMBERS 47 THRU 377
- C** FOR CUM LINE NUMBERS 378 AND ON

Section 44 Main Landing Gear Wheel Well Structure Identification
Figure 1 (Sheet 1 of 3)

**757-200
STRUCTURAL REPAIR MANUAL**

REF DWG
144N8006



**Section 44 Main Landing Gear Wheel Well Structure Identification
Figure 1 (Sheet 2 of 3)**

IDENTIFICATION 1
Page 2
Jan 20/2005

53-40-14

D634N201



**757-200
STRUCTURAL REPAIR MANUAL**

ITEM	DESCRIPTION	GAGE	MATERIAL	EFFECTIVITY			
1	STIFFENER		BAC1518-831 7075-T73511	<table border="1"> <tr><td>A</td></tr> <tr><td>B</td></tr> <tr><td>C</td></tr> </table>	A	B	C
A							
B							
C							
2	STIFFENER		BAC1518-832 7075-T73511				
3	CHORD		BAC1505-10126 7075-T73511				
4	STIFFENER		BAC1503-100691 7075-T73511				
5	STIFFENER		BAC1506-3378 7075-T73511				
6	STIFFENER		BAC1506-3377 7050-T73511				
7	WEB	0.180	2024-T3 (CHEM-MILLED TO 0.060)				
		0.180	2024-T3 (CHEM-MILLED TO 0.080)				
		0.180	2024-T3 (CHEM-MILLED TO 0.095)				
8	WEB	0.112	2024-T3				
9	FITTING		FORGING 7175-T736				
10	CHORD		BAC1505-101100 7075-T73				
11	WEB	0.04	CLAD 7075-T6				
12	CHORD	0.05	CLAD 7075-T6				
13	CHANNEL	0.05	CLAD 7075-T6				
14	ANGLE	0.062	CLAD 7075-T6				

LIST OF MATERIALS FOR DETAIL I

**Section 44 Main Landing Gear Wheel Well Structure Identification
Figure 1 (Sheet 3 of 3)**

D634N201

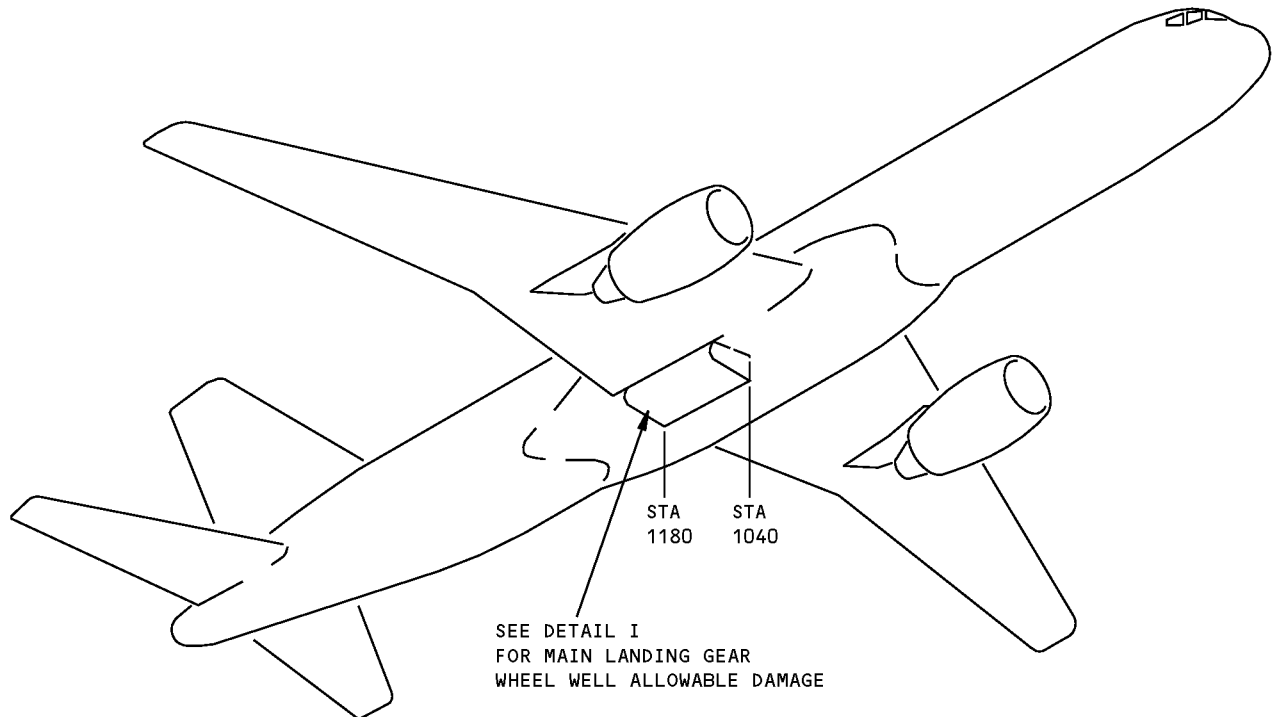
53-40-14

IDENTIFICATION 1
Page 3
Jan 20/2005



757-200
STRUCTURAL REPAIR MANUAL

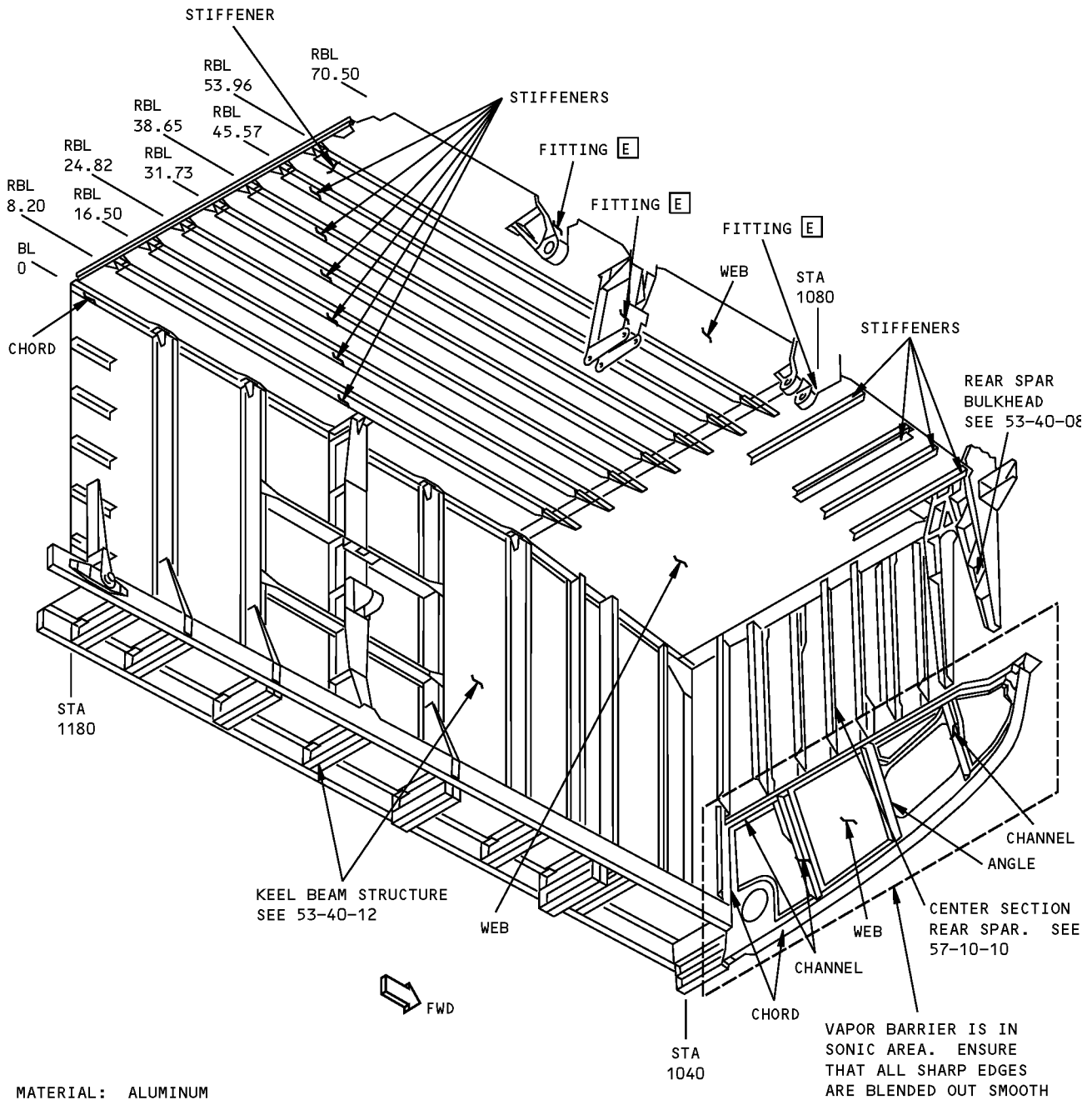
ALLOWABLE DAMAGE 1 - SECTION 44 - MAIN LANDING GEAR WHEEL WELL STRUCTURE



**Section 44 Main Landing Gear Wheel Well Structure Allowable Damage
Figure 101 (Sheet 1 of 6)**

**757-200
STRUCTURAL REPAIR MANUAL**

REF DWG
144N8006



DETAIL I

**Section 44 Main Landing Gear Wheel Well Structure Allowable Damage
Figure 101 (Sheet 2 of 6)**

ALLOWABLE DAMAGE 1

53-40-14

Page 102
Jan 20/2005

D634N201



757-200
STRUCTURAL REPAIR MANUAL

DESCRIPTION	CRACKS	NICKS, GOUGES AND CORROSION	DENTS	HOLES AND PUNCTURES
STIFFENERS	A	B	NOT ALLOWED	SEE DETAIL VIII
FITTINGS E	A	C	NOT ALLOWED	NOT ALLOWED
WEBS	D	B	SEE DETAIL IV	F
CHANNELS	A	B	SEE DETAIL IV	SEE DETAIL VIII
ANGLE	A	B	SEE DETAIL IV	SEE DETAIL VIII
CHORDS	A	B	NOT ALLOWED	NOT ALLOWED

NOTES

- REFINISH REWORKED AREAS PER 51-20 OF THE MAINTENANCE MANUAL

A CRACKS NOT ALLOWED EXCEPT FOR EDGE CRACKS WHICH MUST BE REMOVED PER DETAILS II AND VII

B REMOVE DAMAGE PER DETAILS II, III, AND V

C FOR EDGE DAMAGE SEE DETAIL X. FOR LUG DAMAGE SEE DETAIL IX. FOR OTHER DAMAGE SEE DETAIL III. DAMAGE NOT ALLOWED IN VICINITY OF BUSHINGS. SEE DETAIL I FOR APPLICABLE SHOT PEEN REQUIREMENTS

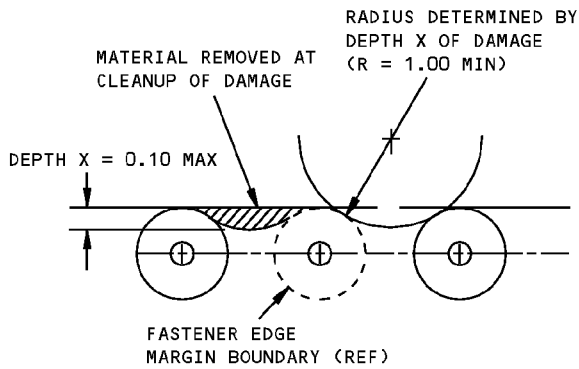
D CRACKS NOT ALLOWED EXCEPT FOR EDGE CRACKS WHICH MUST BE REMOVED PER DETAILS II AND VI

E SHOT PEEN REWORKED AREAS PER 51-20-06

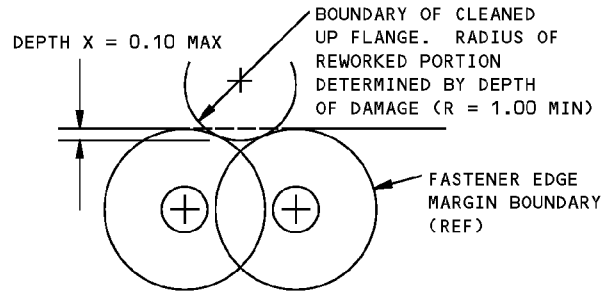
F CLEAN OUT DAMAGE UP TO 0.25 MAX DIA AND NOT CLOSER THAN 1.0 INCH TO FASTENER HOLE OR OTHER DAMAGE. MAINTAIN 2.0D EDGE MARGIN ON PART EDGE. FILL HOLE WITH A 2117-T3 OR T4 ALUMINUM RIVET INSTALLED WET WITH BMS 5-95 SEALANT. ALL OTHER HOLES TO BE REPAIRED

Section 44 Main Landing Gear Wheel Well Structure Allowable Damage
Figure 101 (Sheet 3 of 6)

**757-200
STRUCTURAL REPAIR MANUAL**

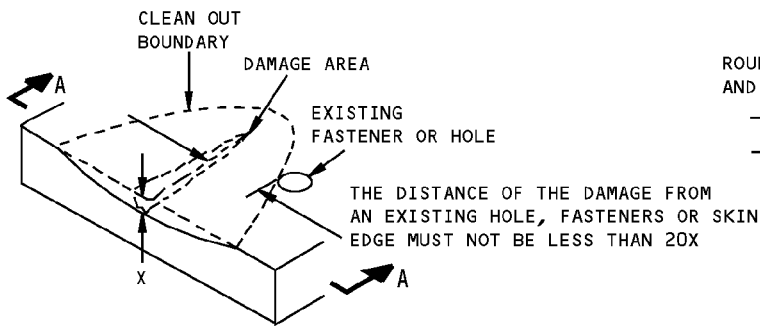


DAMAGE CLEANUP OF EDGES WHERE FASTENER EDGE MARGINS DO NOT OVERLAP

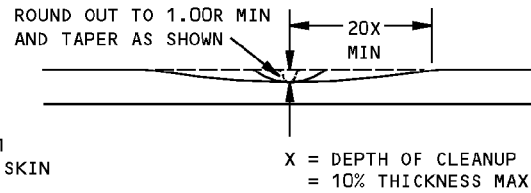


DAMAGE CLEANUP OF EDGES WHERE FASTENER EDGE MARGINS OVERLAP

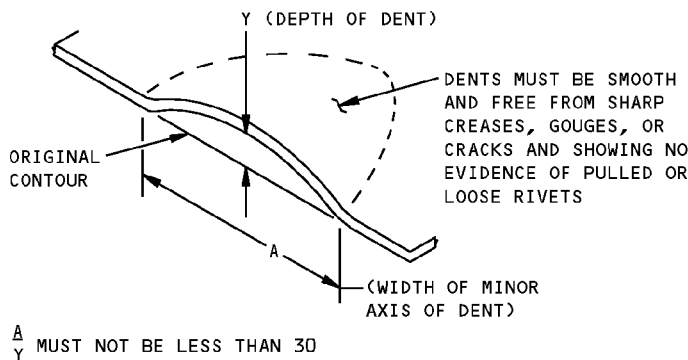
DETAIL II



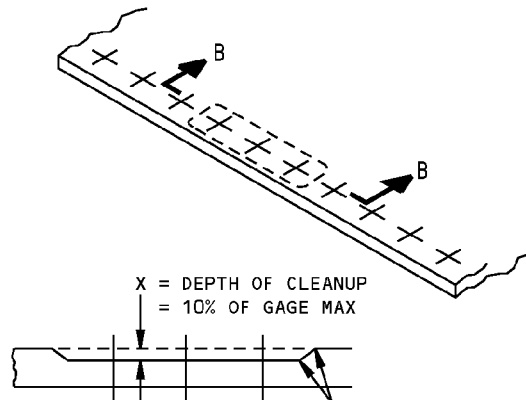
**REMOVAL OF NICK, GOUGE AND SCRATCH DAMAGE ON A SURFACE
DETAIL III**



SECTION A-A



**ALLOWABLE DAMAGE FOR DENT
DETAIL IV**

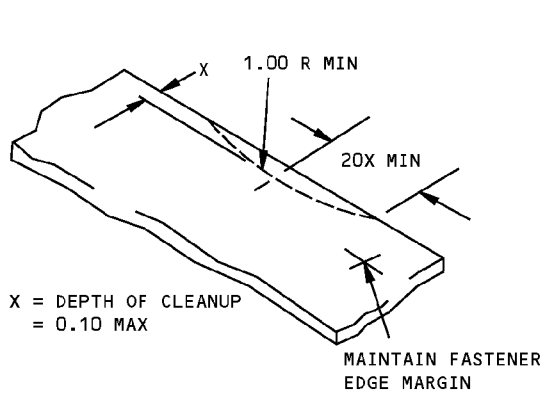


SMOOTH BLEND-OUT RADIUS 0.50 INCH MINIMUM. CORROSION CLEANUP AROUND ANY THREE FASTENERS IN TEN IS PERMITTED TO MAX DEPTH

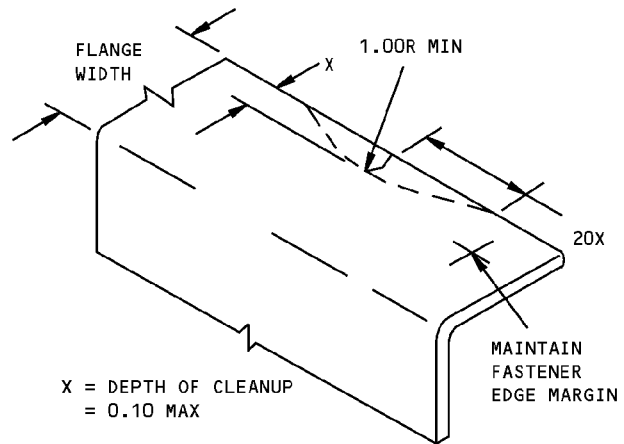
**SECTION B-B
CORROSION CLEANUP
DETAIL V**

**Section 44 Main Landing Gear Wheel Well Structure Allowable Damage
Figure 101 (Sheet 4 of 6)**

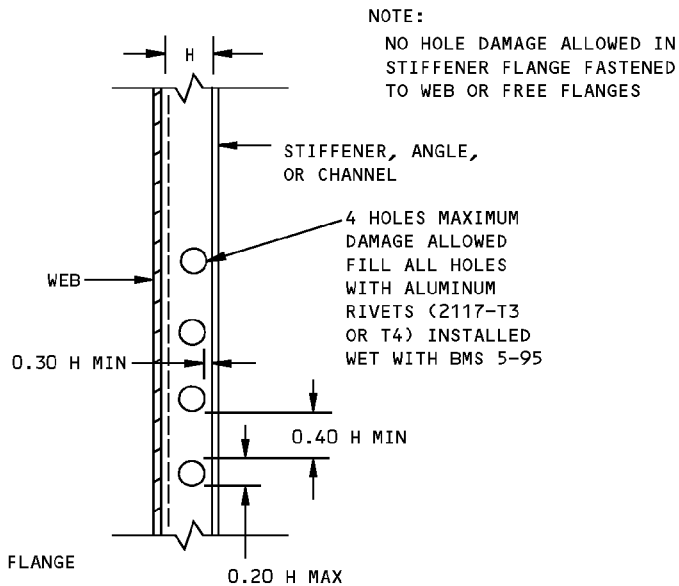
**757-200
STRUCTURAL REPAIR MANUAL**



**REMOVAL OF NICK OR CRACK
DAMAGE ON AN EDGE
DETAIL VI**



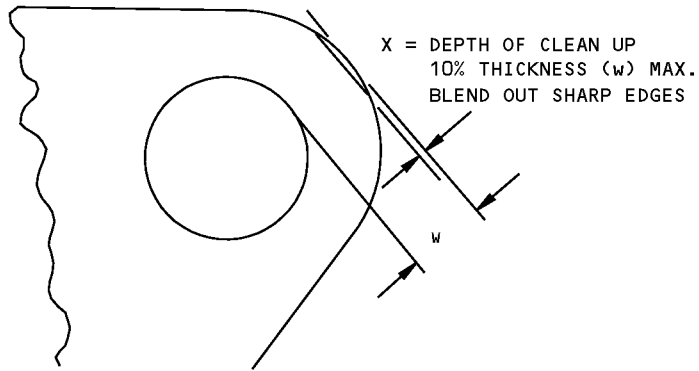
**REMOVAL OF NICK OR CRACK
DAMAGE ON AN EDGE
DETAIL VII**



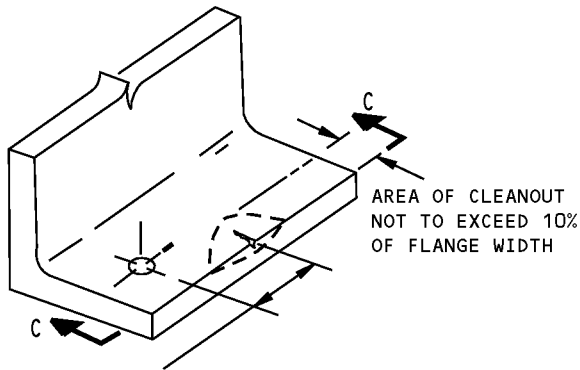
**ALLOWABLE DAMAGE LIMITS FOR
HOLES IN STIFFENERS, ANGLES, AND CHANNELS
DETAIL VIII**

**Section 44 Main Landing Gear Wheel Well Structure Allowable Damage
Figure 101 (Sheet 5 of 6)**

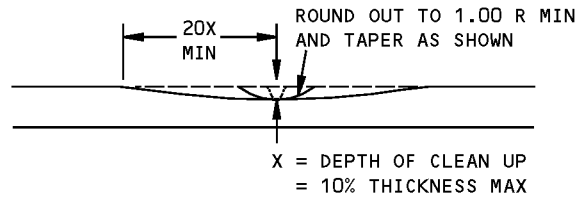
**757-200
STRUCTURAL REPAIR MANUAL**



**DAMAGE CLEAN UP FOR EDGES OF LUG
DETAIL IX**



THE DISTANCE OF THE DAMAGE FROM AN EXISTING HOLE, FASTENERS OR EDGE MUST NOT BE LESS THAN 20X



**REMOVAL OF NICK OR CRACK
DAMAGE ON AN EDGE
SECTION C-C**

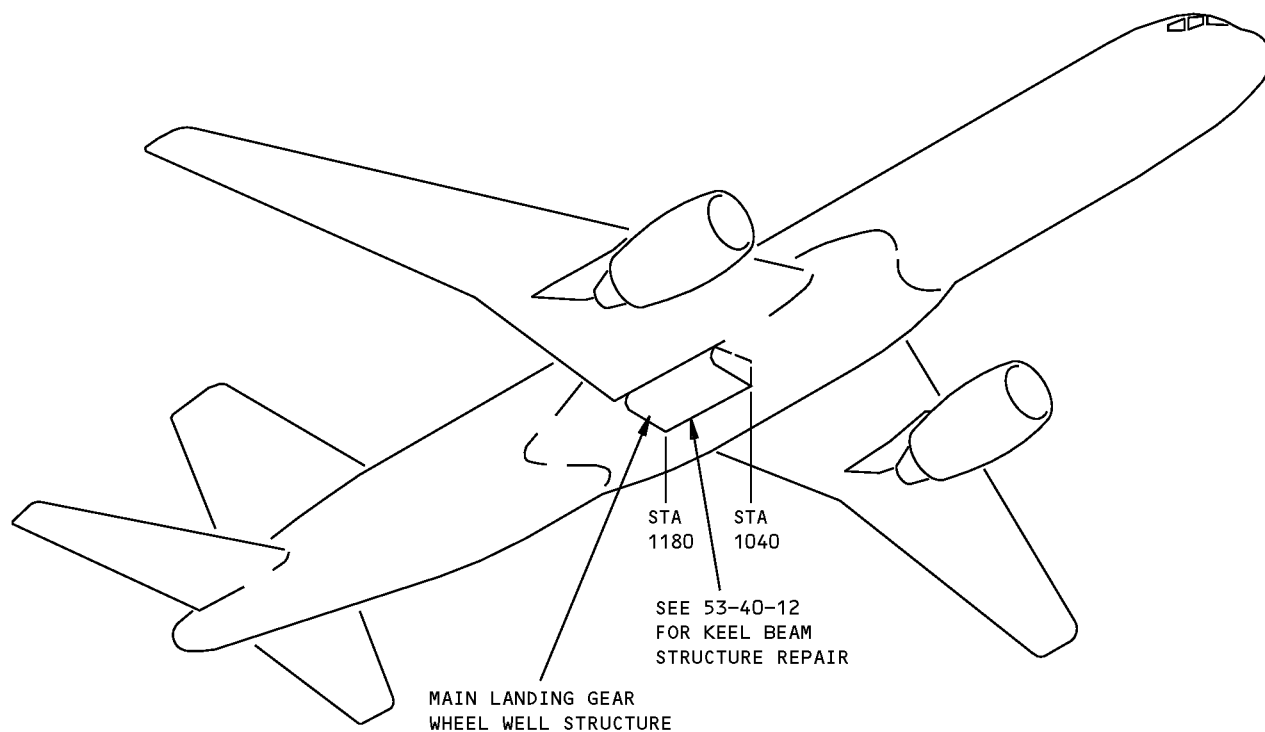
DETAIL X

**Section 44 Main Landing Gear Wheel Well Structure Allowable Damage
Figure 101 (Sheet 6 of 6)**

757-200
STRUCTURAL REPAIR MANUAL

REPAIR GENERAL - SECTION 44 - MAIN LANDING GEAR WHEEL WELL STRUCTURE REPAIR

APPLICABILITY
THIS REPAIR DOES NOT APPLY TO PRESSURE DECK WEBS, B.S. 1180 BULKHEAD WEBS, WING CENTER SECTION REAR SPAR STRUCTURE AND EXTRUDED WEB STIFFENERS



NOTES

- SEE 51-70-11 FOR FORMED SECTION REPAIR
- SEE 51-70-12 FOR EXTRUDED SECTION REPAIR
- SEE 51-70-13 FOR WEB REPAIR
- NO REPAIRS ALLOWED TO FITTINGS

**Section 44 Main Landing Gear Wheel Well Structure Repair
Figure 201**

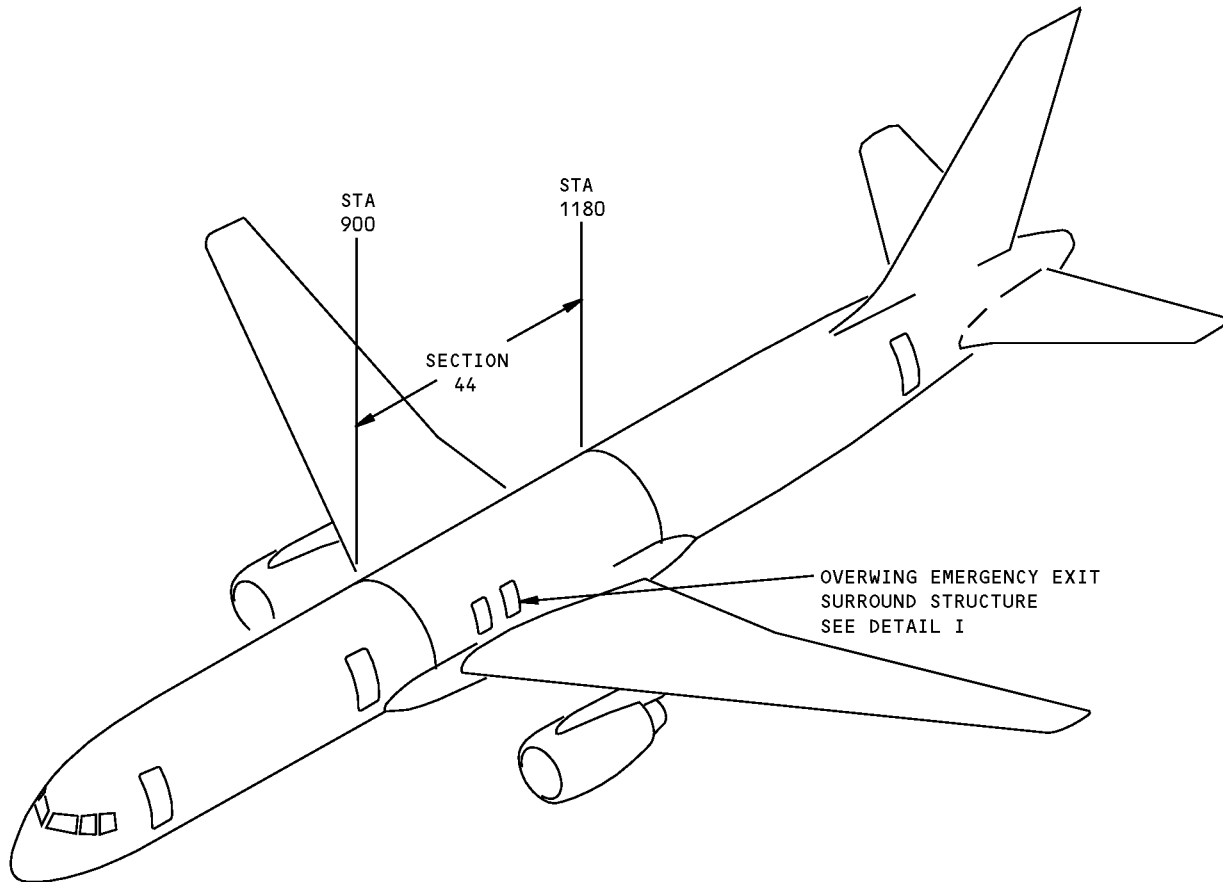
D634N201

53-40-14

REPAIR GENERAL
Page 201
Jan 20/2005

757-200
STRUCTURAL REPAIR MANUAL

IDENTIFICATION 1 - SECTION 44 - DOOR SURROUND STRUCTURE



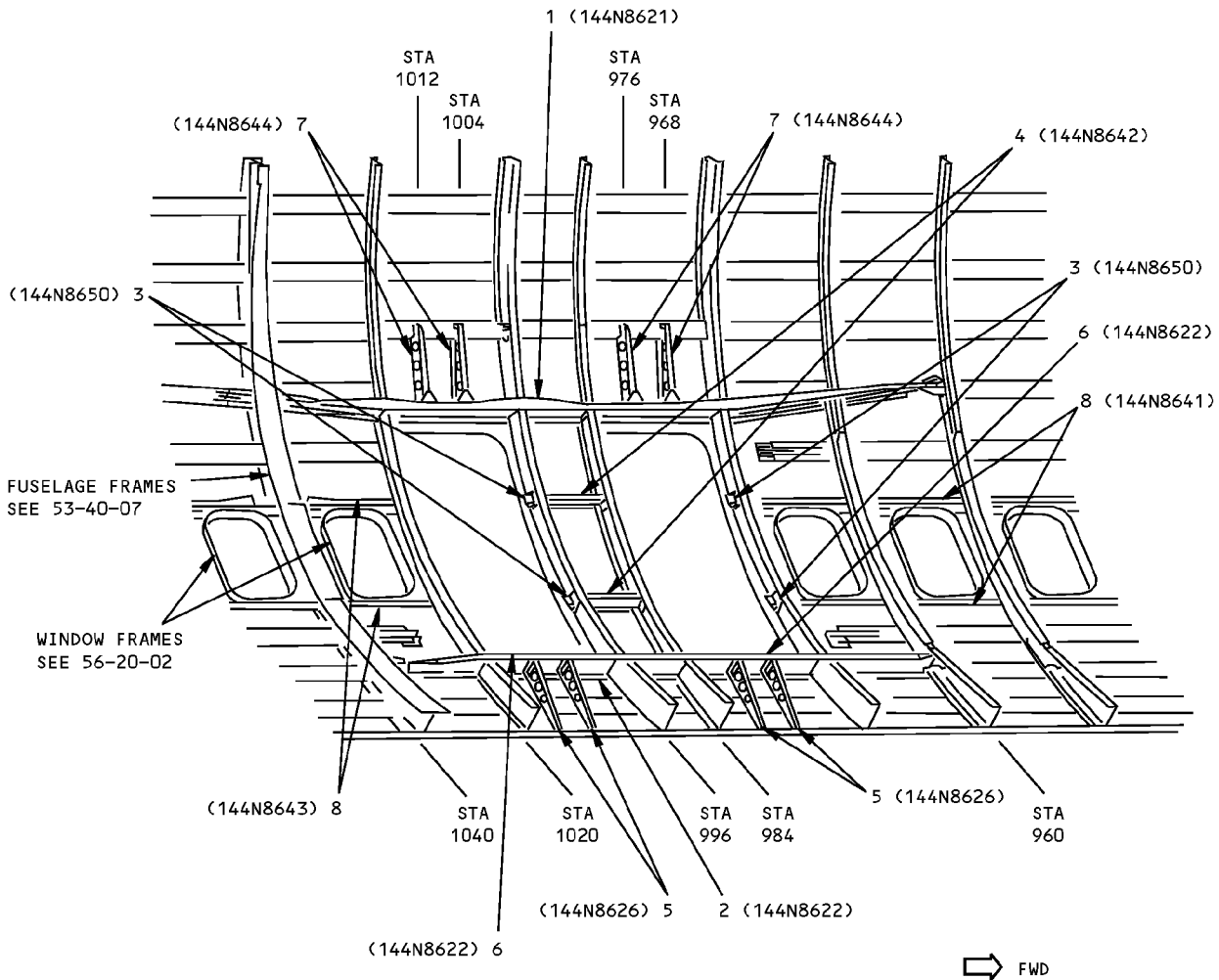
NOTES

- A** FOR CUM LINE NUMBERS:
37,39,41,43 THRU 49
- B** SILL WEB THICKNESSES VARY.
THIS THICKNESS IS USED BETWEEN
STA 996 AND STA 1020
- C** SILL WEB THICKNESSES VARY.
THIS THICKNESS IS USED AT STATIONS
NOT IN **B**

Section 44 Door Surround Structure Identification
Figure 1 (Sheet 1 of 3)

**757-200
STRUCTURAL REPAIR MANUAL**

REF DWG
144N0001



LEFT SIDE SHOWN
RIGHT SIDE OPPOSITE
DETAIL I

**Section 44 Door Surround Structure Identification
Figure 1 (Sheet 2 of 3)**

IDENTIFICATION 1
Page 2
Jan 20/2005

53-40-15

D634N201



**757-200
STRUCTURAL REPAIR MANUAL**

ITEM	DESCRIPTION	GAGE	MATERIAL	EFFECTIVITY
1	UPPER SILL	0.190	2024-T3	<div style="display: flex; flex-direction: column; align-items: center;"> <div style="border: 1px solid black; padding: 2px; margin: 2px;">A</div> <div style="border: 1px solid black; padding: 2px; margin: 2px;">B</div> <div style="border: 1px solid black; padding: 2px; margin: 2px;">C</div> </div>
	INNER CHORD OUTER CHORD		BAC1508-250 7075-T73 OR 7075-T73	
	WEB	0.063	7075-T6	
	WEB	0.071	7075-T6	
2	LOWER SILL	0.190	2024-T3	<div style="display: flex; flex-direction: column; align-items: center;"> <div style="border: 1px solid black; padding: 2px; margin: 2px;">B</div> <div style="border: 1px solid black; padding: 2px; margin: 2px;">C</div> </div>
	INNER CHORD OUTER CHORD		BAC1505-100852 7075-T73511 7075-T6	
	WEB	0.063	7075-T6	
	WEB	0.071	7075-T6	
3	STOP FITTING	2.00	7075-T73 FORGING OR 7075-T73511	<div style="border: 1px solid black; padding: 2px; margin: 2px;">A</div>
4	INTERCOSTAL	0.071	7075-T6	
	WEB BACKUP TEE		7075-T73 FORGING OR BAC1505-100106 7075-T73511	
5	LOWER SILL INTER- COSTALS	0.071	7075-T6	
6	THRESHOLD	0.063	7075-T6	
7	UPPER SILL INTER- COSTAL	0.100	7075-T6	
	ANGLE		BAC1505-101100 7075-T73511	
	TEE CLIP WEB	0.056	7075-T6	
8	INTERCOSTAL BACKUP TEE		7075-T73 FORGING OR BAC1505-100156 7075-T73511	
	BACKUP FITTING		7075-T73 FORGING OR BAC1506-3036 7075-T73511	

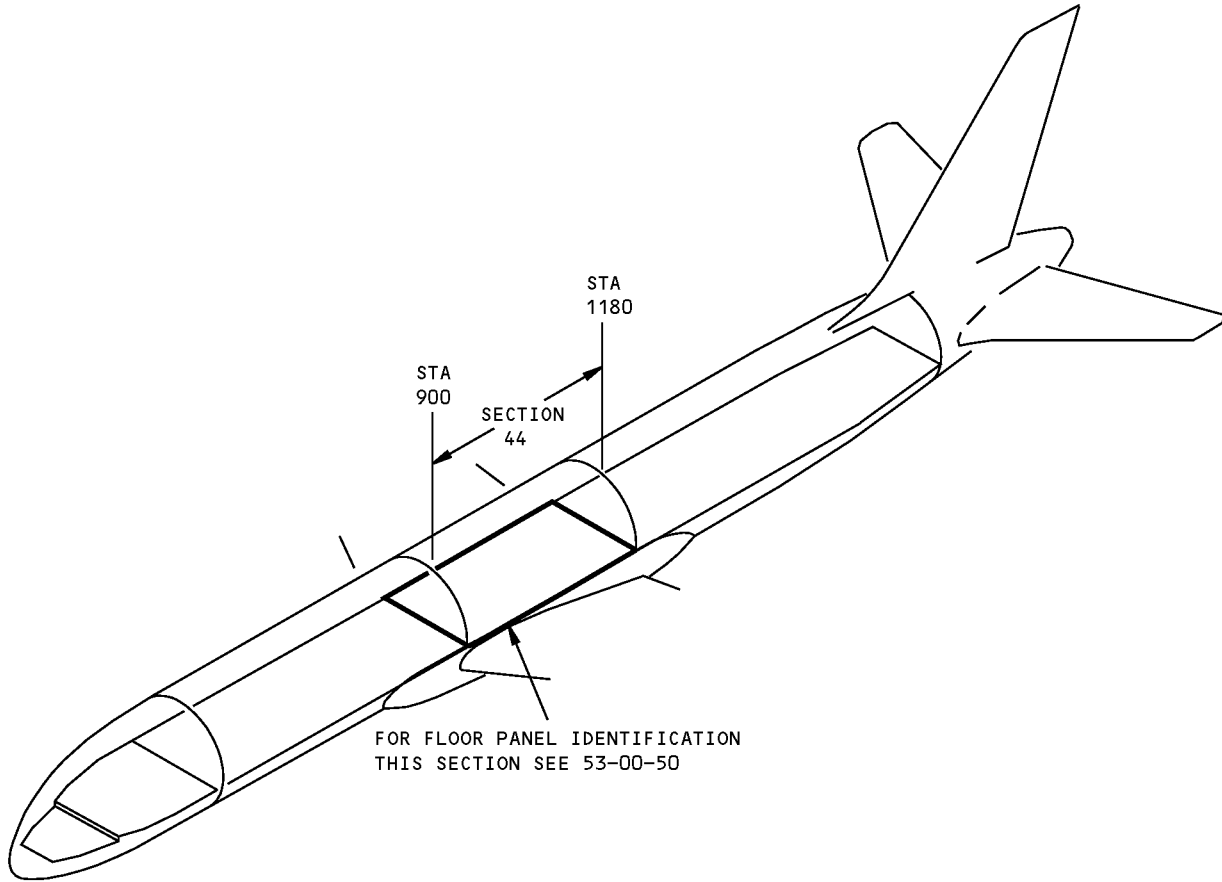
LIST OF MATERIALS FOR DETAIL I

**Section 44 Door Surround Structure Identification
Figure 1 (Sheet 3 of 3)**



757-200
STRUCTURAL REPAIR MANUAL

IDENTIFICATION GENERAL - SECTION 44 - MAIN DECK FLOOR PANEL



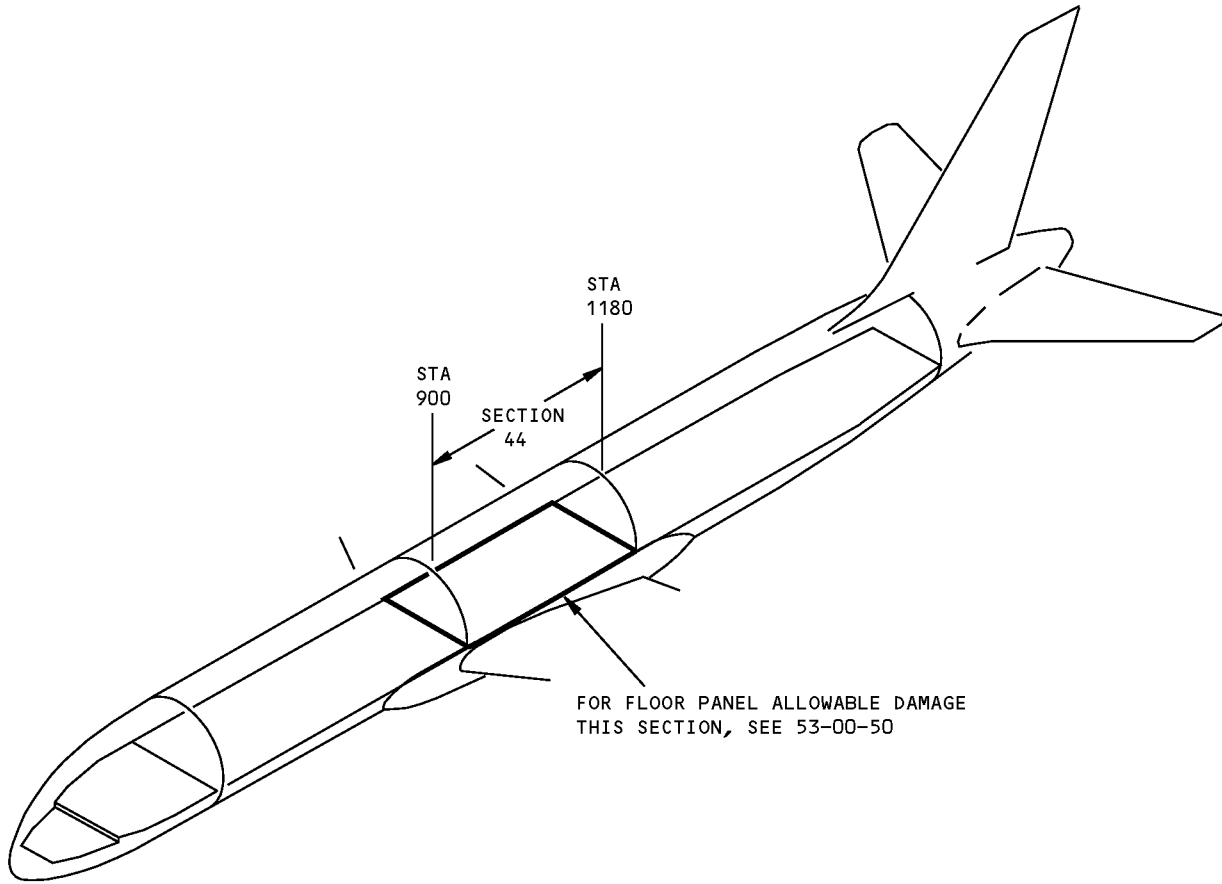
Section 44 Main Deck Floor Panel Identification
Figure 1

D634N201

IDENTIFICATION GENERAL
Page 1
53-40-50 Jan 20/2005

**757-200
STRUCTURAL REPAIR MANUAL**

ALLOWABLE DAMAGE GENERAL - SECTION 44 - MAIN DECK FLOOR PANELS



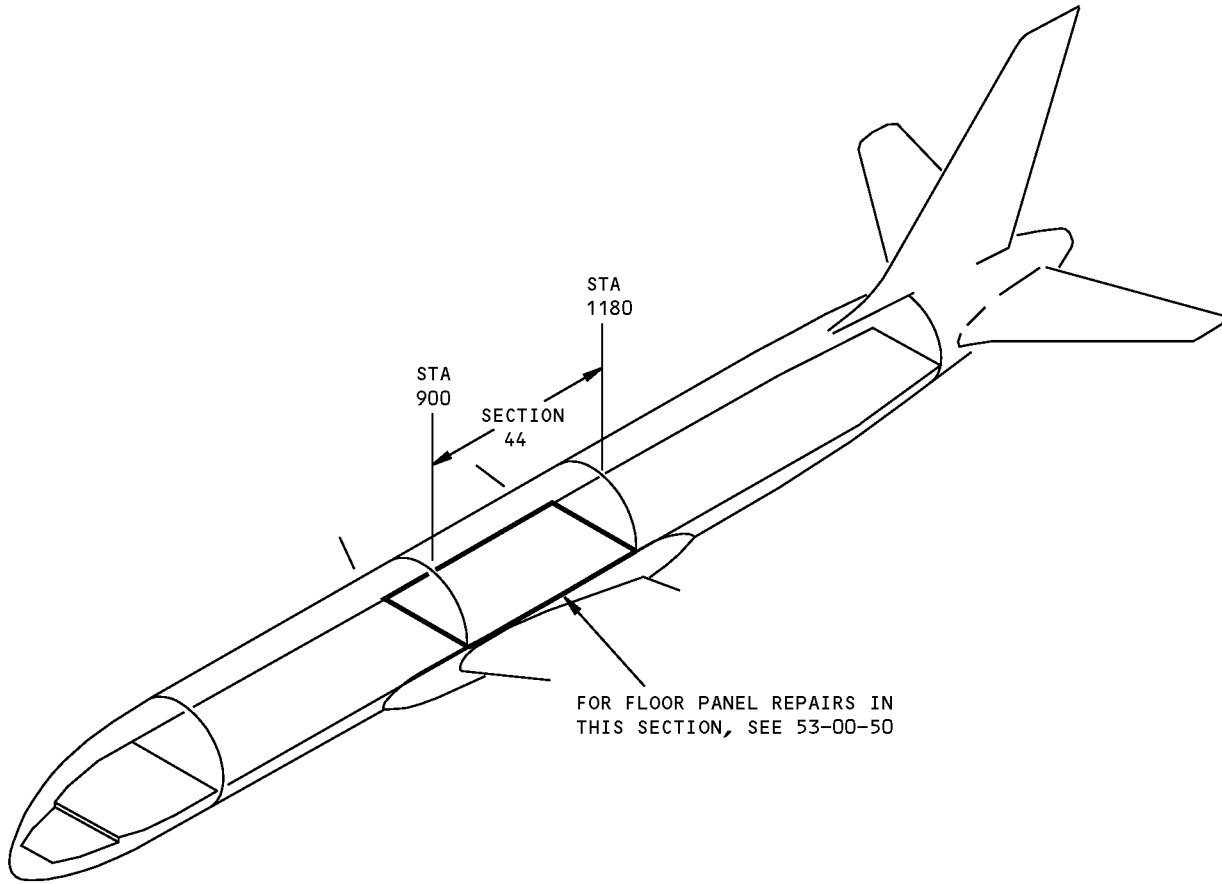
**Section 44 Main Deck Floor Panel Allowable Damage
Figure 101**

D634N201



**757-200
STRUCTURAL REPAIR MANUAL**

REPAIR GENERAL - SECTION 44 - MAIN DECK FLOOR PANELS



**Section 44 Main Deck Floor Panel Repair
Figure 201**

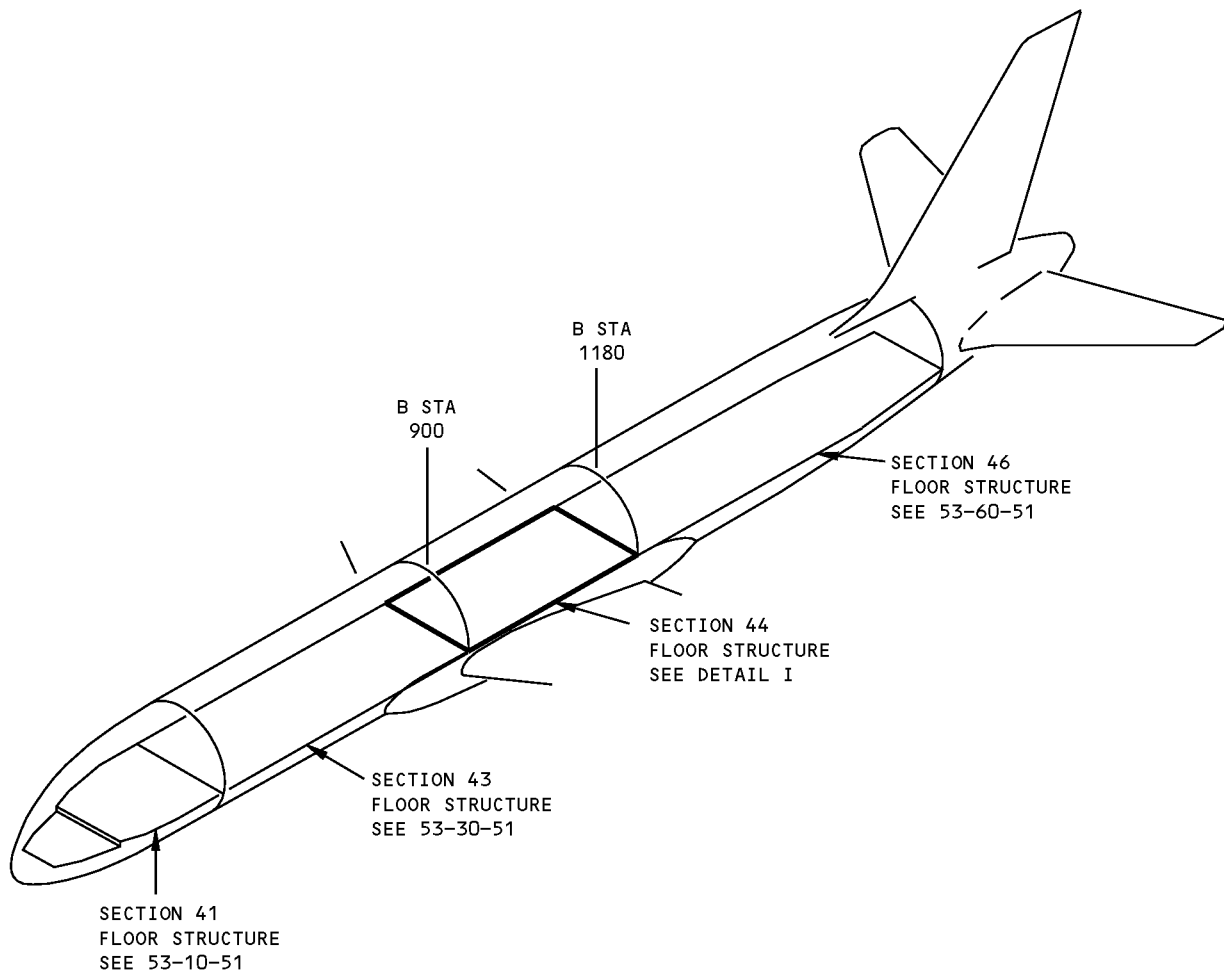
D634N201

53-40-50

REPAIR GENERAL
Page 201
Jan 20/2005

**757-200
STRUCTURAL REPAIR MANUAL**

IDENTIFICATION 1 - SECTION 44 - FLOOR STRUCTURE



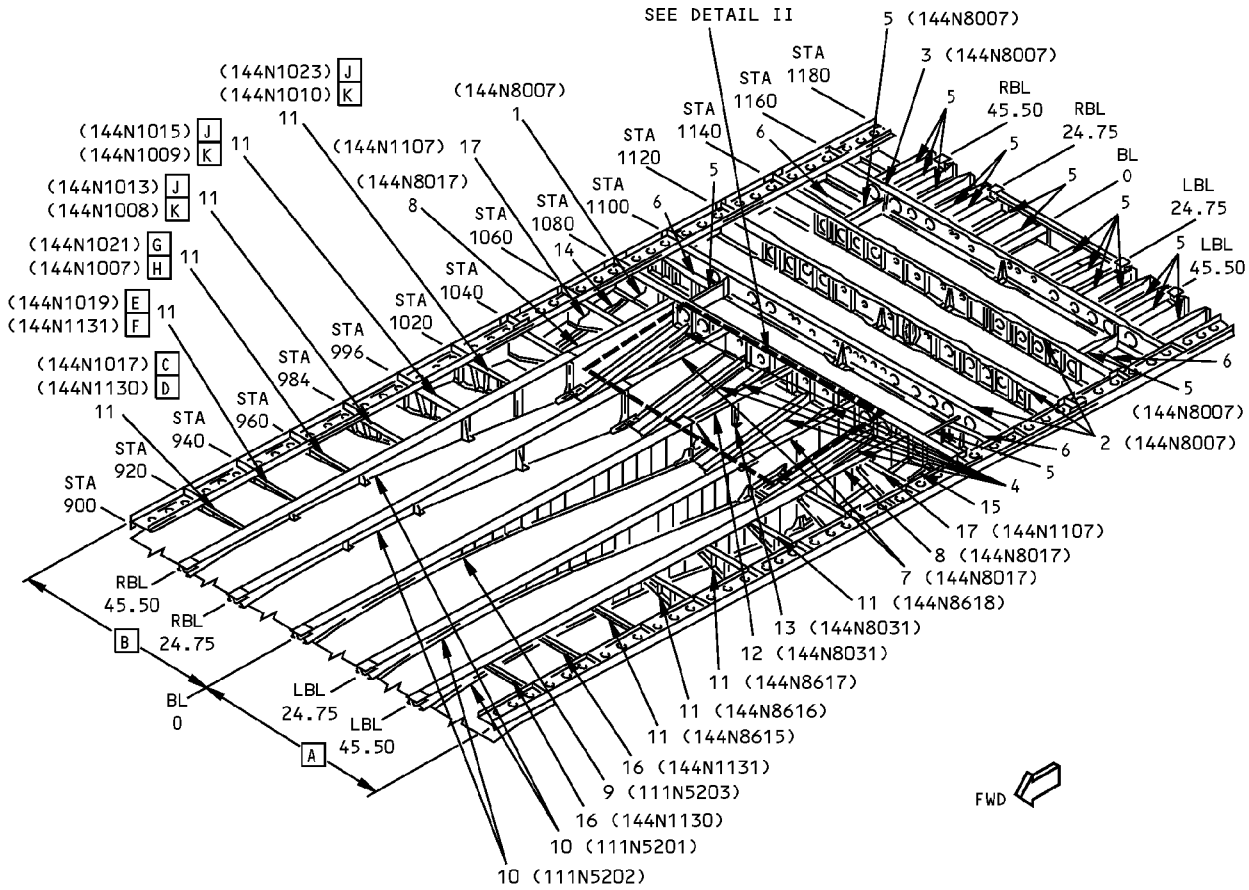
NOTES

- | | |
|--|---|
| <p>A LEFT SIDE SHOWN FOR AIRPLANES WITH OVERWING EMERGENCY EXITS</p> <p>B RIGHT SIDE SHOWN FOR AIRPLANES WITHOUT OVERWING EMERGENCY EXITS</p> <p>C FOR CUM LINE NUMBERS 1 THRU 244</p> <p>D FOR AIRPLANES NOT LISTED IN C</p> <p>E FOR CUM LINE NUMBERS 1 THRU 163</p> | <p>F FOR AIRPLANES NOT LISTED IN E</p> <p>G FOR CUM LINE NUMBERS 1 THRU 190</p> <p>H FOR AIRPLANES NOT LISTED IN G</p> <p>J FOR CUM LINE NUMBERS 1 THRU 228</p> <p>K FOR AIRPLANES NOT LISTED IN J</p> <p>L FOR CUM LINE NUMBERS 47 THRU 377</p> |
|--|---|

**Section 44 Floor Structure Identification
Figure 1 (Sheet 1 of 4)**

**757-200
STRUCTURAL REPAIR MANUAL**

REF DWGS
144N8006
111N0001



REFER TO NOTES FOR AIRPLANE CONFIGURATION
DETAIL I



**Section 44 Floor Structure Identification
Figure 1 (Sheet 2 of 4)**

IDENTIFICATION 1
Page 2
Jan 20/2005

53-40-51

D634N201



**757-200
STRUCTURAL REPAIR MANUAL**

ITEM	DESCRIPTION	GAGE	MATERIAL	EFFECTIVITY
1	FLOOR BEAM UPPER CHORD WEB LOWER CHORD	0.125	BAC1505-101254 7075-T6511 2024-T3 BAC1505-101252 7075-T6511	
2	FLOOR BEAM UPPER CHORD WEB LOWER CHORD	0.125	BAC1505-101254 7075-T6511 2024-T3 BAC1505-101255 7050-T76511	
3	FLOOR BEAM UPPER CHORD WEB LOWER CHORD	0.125	BAC1505-101253 2024-T3511 2024-T3 BAC1505-101255 7050-T76511	
4	STIFFENER		BAC1518-281 7075-T73511	
5	INTERCOSTAL		BAC1518-653 7075-T73511	
6	BEAM UPPER CHORD WEB LOWER CHORD	0.070	AND10136-1707 7075-T6 7075-T6 BAC1505-101255 7075-T76511	
7	STUB BEAM UPPER CHORD WEB LOWER CHORD	0.063	BAC1506-1108 7075-T6511 2024-T3 BAC1505-101239 7075-T73511	
8	STUB BEAM UPPER CHORD WEB LOWER CHORD	0.063	BAC1506-1108 7075-T6511 2024-T3 BAC1505-101240 7075-T73511	
9	FLOOR BEAM UPPER CHORD WEB LOWER CHORD FWD AFT	0.250	BAC1506-3336 7075-T6511 2025-T351 BAC1506-3337 7075-T73 BAC1506-3338 7075-T73	
10	FLOOR BEAM UPPER CHORD WEB LOWER CHORD FWD AFT	0.250	BAC1506-1108 7075-T6511 2024-T351 BAC1506-3337 7075-T73 BAC1506-3338 7075-T73	
11	INTERCOSTAL		FORGING 7075-T73 OR FORGED BLOCK 7075-T73	
12	CHANNEL		BAC1510-882 7075-T6511	
13	SUPPORT		AND137-1114 7075-T6511	
14	STIFFENER		BAC1518-828 7075-T73511	
15	STIFFENER		BAC1518-255 7075-T73511	
16	INTERCOSTAL	0.040	7075-T6	
17	BEAM UPPER CHORD WEB LOWER CHORD	0.09	AND10134-3002 2024-T42 2024-T3 BAC1503-100275 7075-T6	

LIST OF MATERIALS FOR DETAIL I

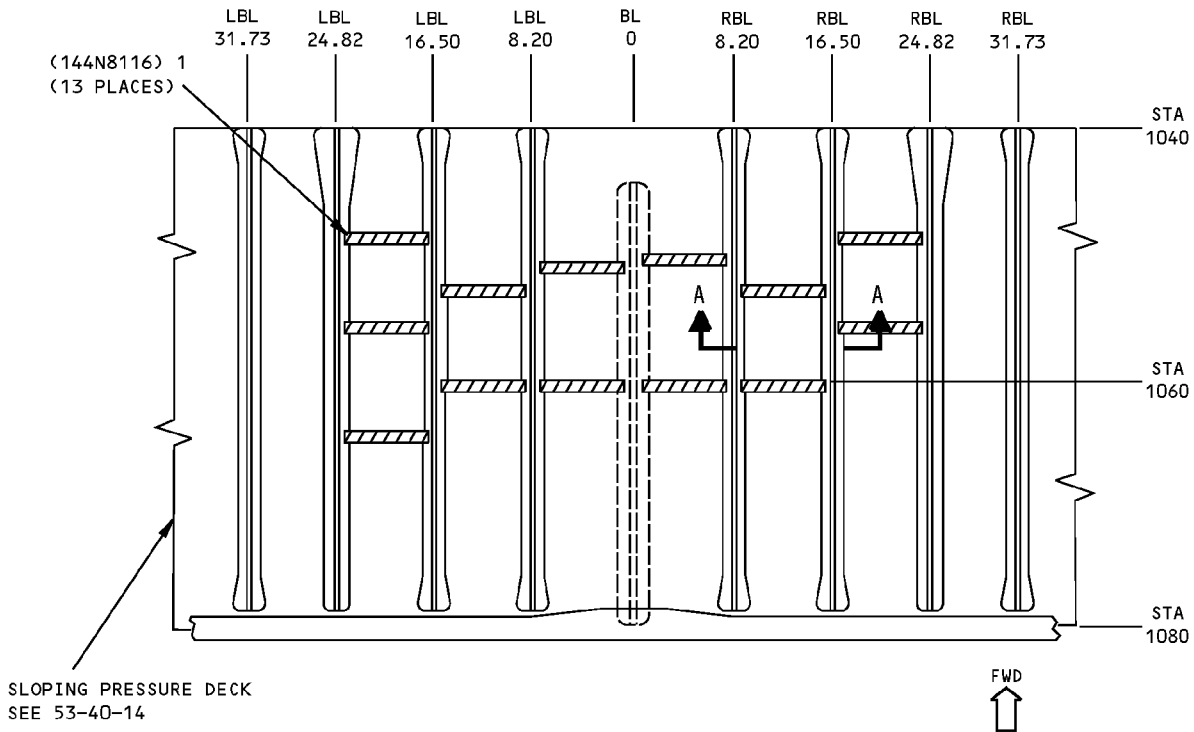
**Section 44 Floor Structure Identification
Figure 1 (Sheet 3 of 4)**

IDENTIFICATION 1
Page 3
Jan 20/2005

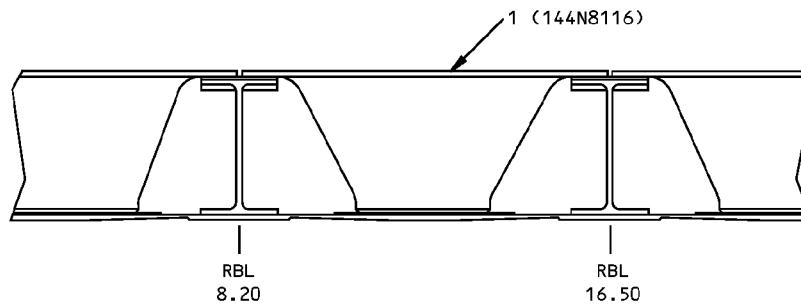
53-40-51

D634N201

**757-200
STRUCTURAL REPAIR MANUAL**



INTERCOSTAL LOCATIONS - WEB SUPPORT



**TYPICAL WEB SUPPORT INTERCOSTAL
(INTERCOSTAL SHAPES VARY)**

**SECTION A-A
DETAIL II**

ITEM	DESCRIPTION	GAGE	MATERIAL	EFFECTIVITY
1	INTERCOSTAL		BAC1518-910 7075-T6511	L

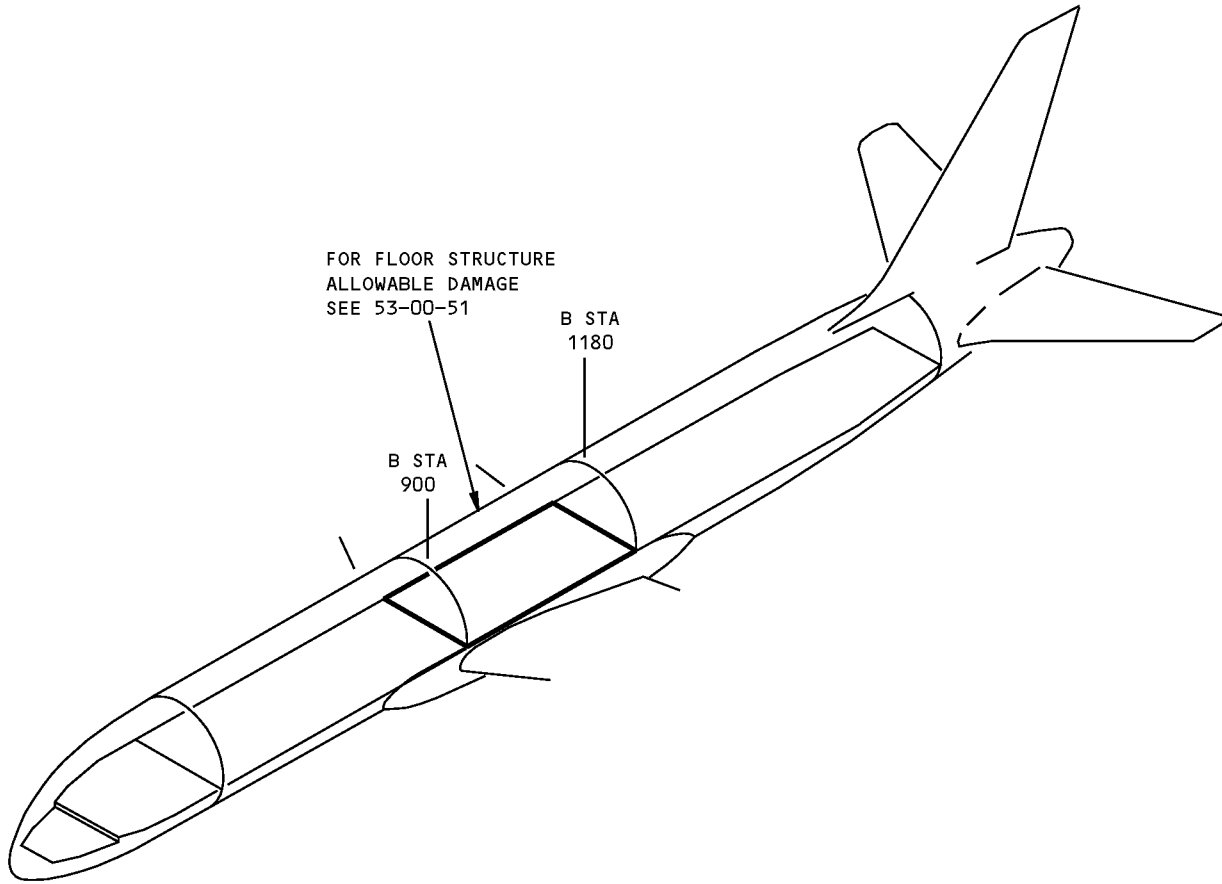
LIST OF MATERIALS FOR DETAIL II

**Section 44 Floor Structure Identification
Figure 1 (Sheet 4 of 4)**



757-200
STRUCTURAL REPAIR MANUAL

ALLOWABLE DAMAGE 1 - SECTION 44 - FLOOR STRUCTURE



Section 44 Floor Structure Allowable Damage
Figure 101

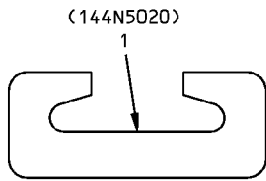
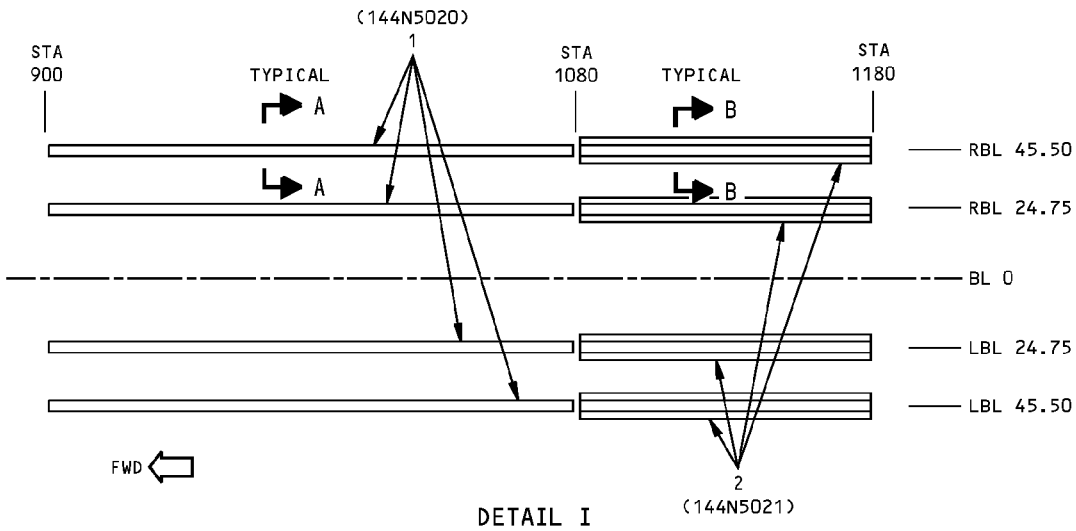
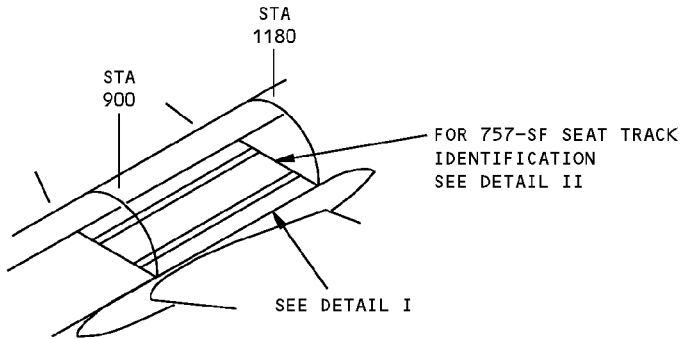
D634N201

ALLOWABLE DAMAGE 1
Page 101
53-40-51
Jan 20/2007

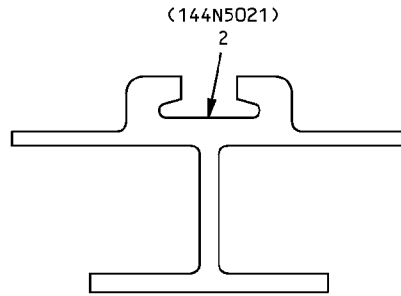
**757-200
STRUCTURAL REPAIR MANUAL**

IDENTIFICATION 1 - SECTION 44 - SEAT TRACKS

REFERENCE DRAWING
144N5001



SECTION A-A



SECTION B-B

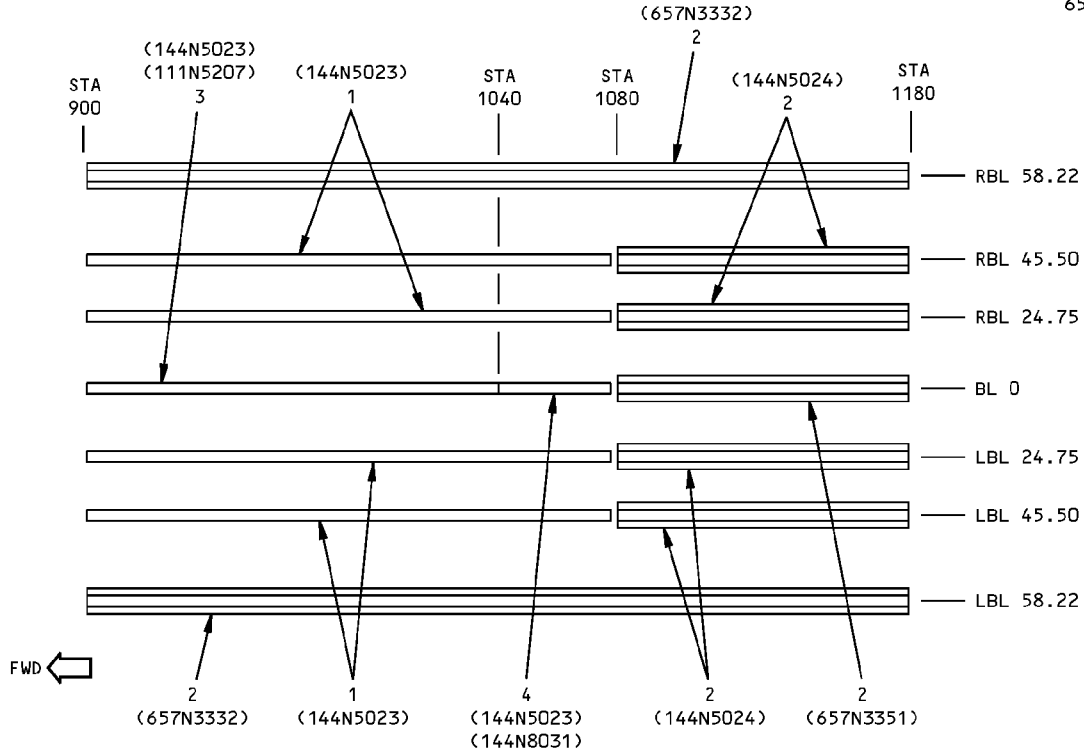
ITEM	DESCRIPTION	GAGE	MATERIAL	EFFECTIVITY
1	SEAT TRACK		BAC1520-841 7178-T6511	
2	SEAT TRACK		BAC1520-792 7178-T6511	

LIST OF MATERIALS FOR DETAIL I

**Section 44 Seat Track Identification
Figure 1 (Sheet 1 of 2)**

**757-200
STRUCTURAL REPAIR MANUAL**

REFERENCE DRAWING
144N5002
657N3311
657N3321
657N3351



DETAIL II

ITEM	DESCRIPTION	GAGE	MATERIAL	EFFECTIVITY
1	SEAT TRACK		BAC1520-841 7178-T6511	
2	SEAT TRACK		BAC1520-792 7178-T6511	
3	SEAT TRACK CROWN SUPPORT		BAC1520-2473 BAC1506-1108 7075-T6511	
4	SEAT TRACK CROWN SUPPORT		BAC1520-2473 BAC1508-240	

LIST OF MATERIALS FOR DETAIL II

**Section 44 Seat Track Identification
Figure 1 (Sheet 2 of 2)**

IDENTIFICATION 1
Page 2
Jan 20/2005

53-40-52

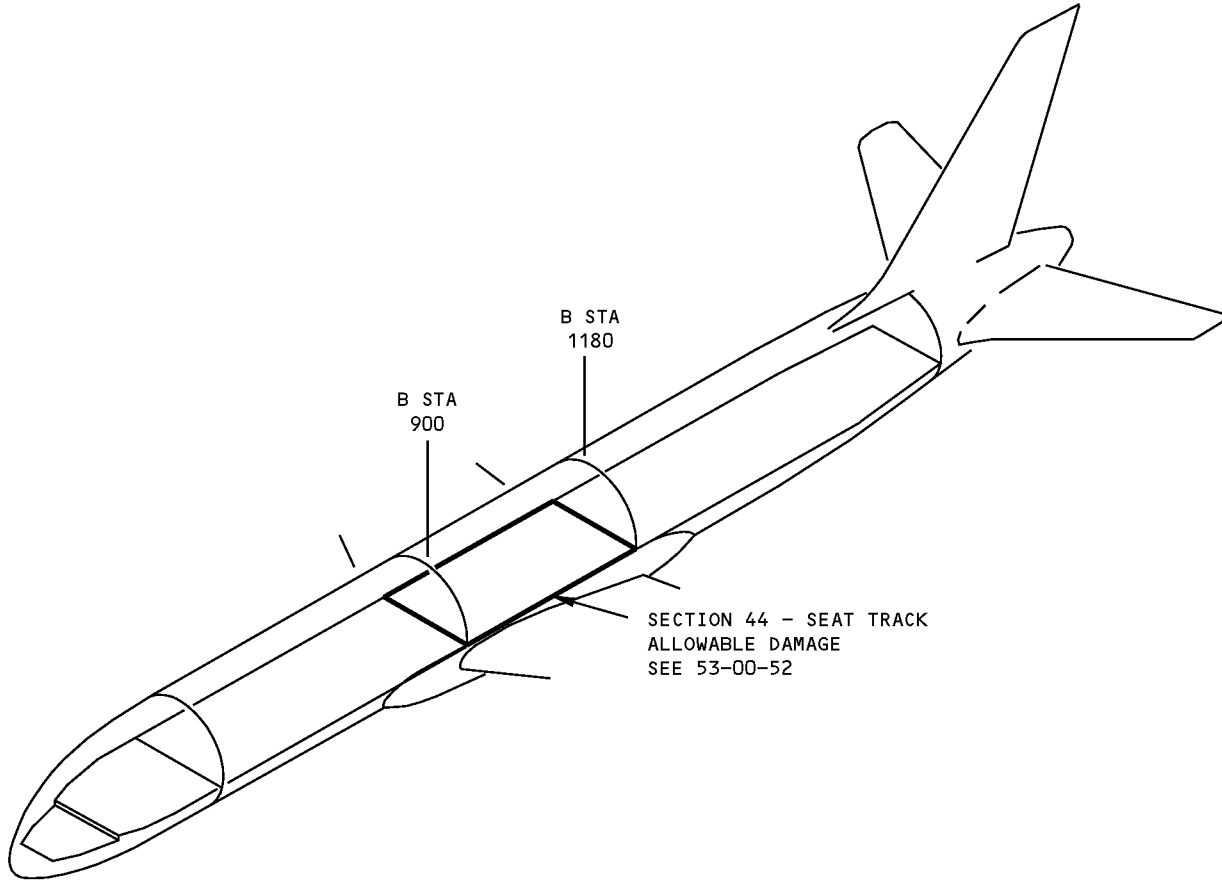
D634N201



757-200
STRUCTURAL REPAIR MANUAL

ALLOWABLE DAMAGE GENERAL - SECTION 44 - SEAT TRACKS

REF DWG
144N5001



Section 44 Seat Track Allowable Damage
Figure 101

D634N201

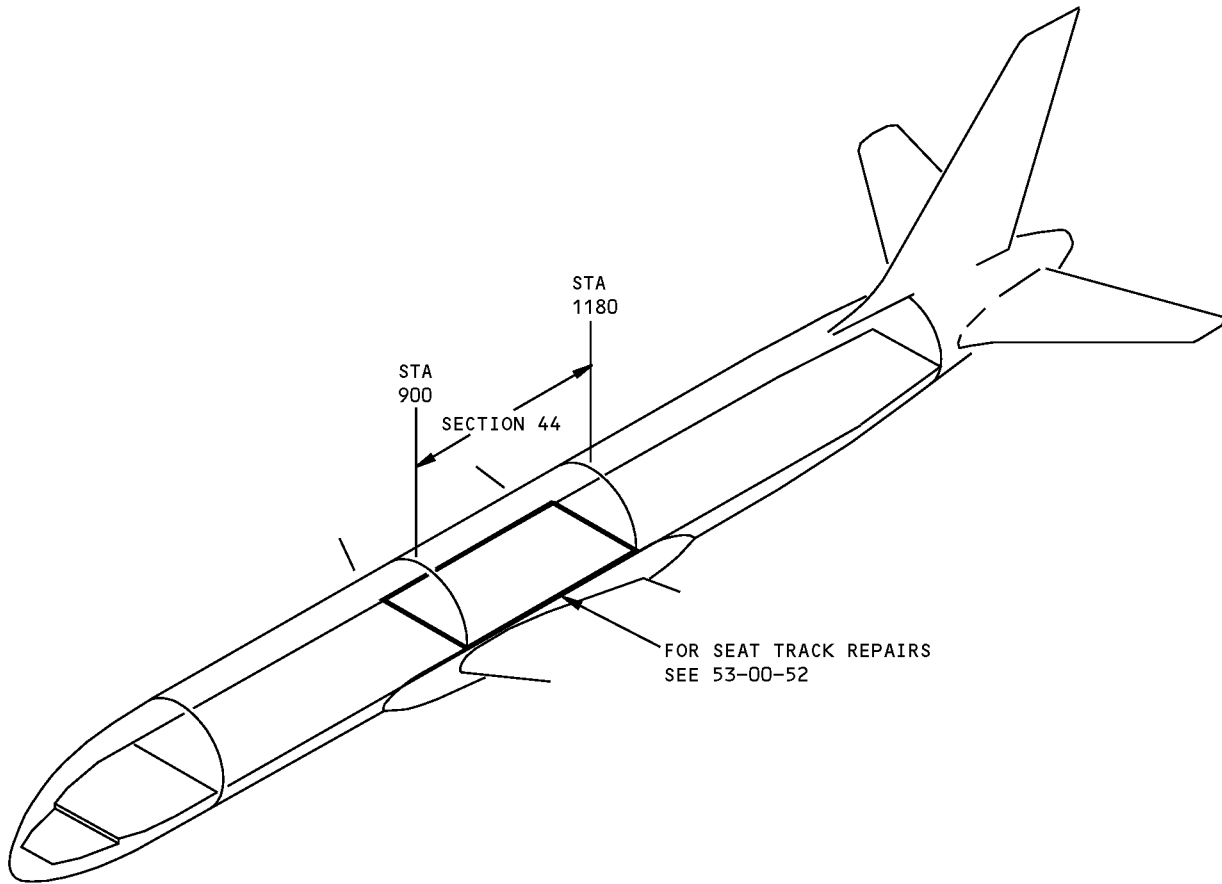
ALLOWABLE DAMAGE GENERAL
53-40-52
Page 101
Jan 20/2007



**757-200
STRUCTURAL REPAIR MANUAL**

REPAIR GENERAL - SECTION 44 - SEAT TRACKS

REF DWG
144N5001



**Section 44 Seat Track Repairs
Figure 201**

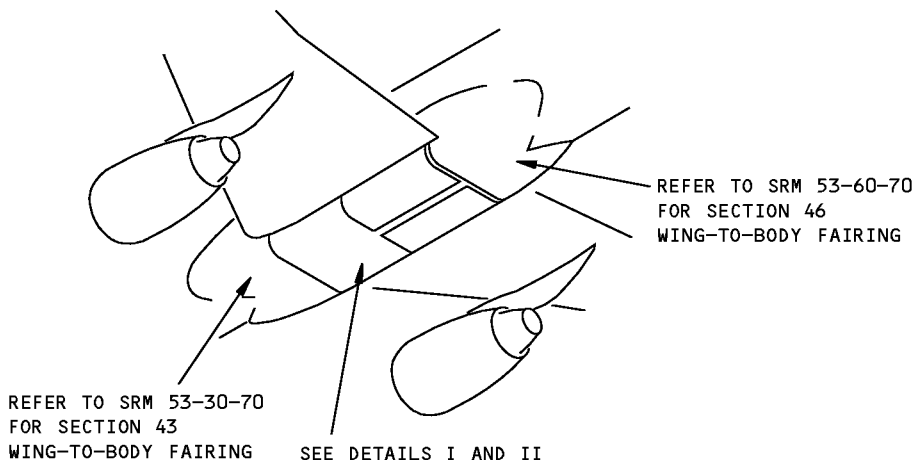
D634N201

53-40-52

REPAIR GENERAL
Page 201
Jan 20/2005

**757-200
STRUCTURAL REPAIR MANUAL**

IDENTIFICATION 1 - SECTION 44 - WING-TO-BODY FAIRING SKINS



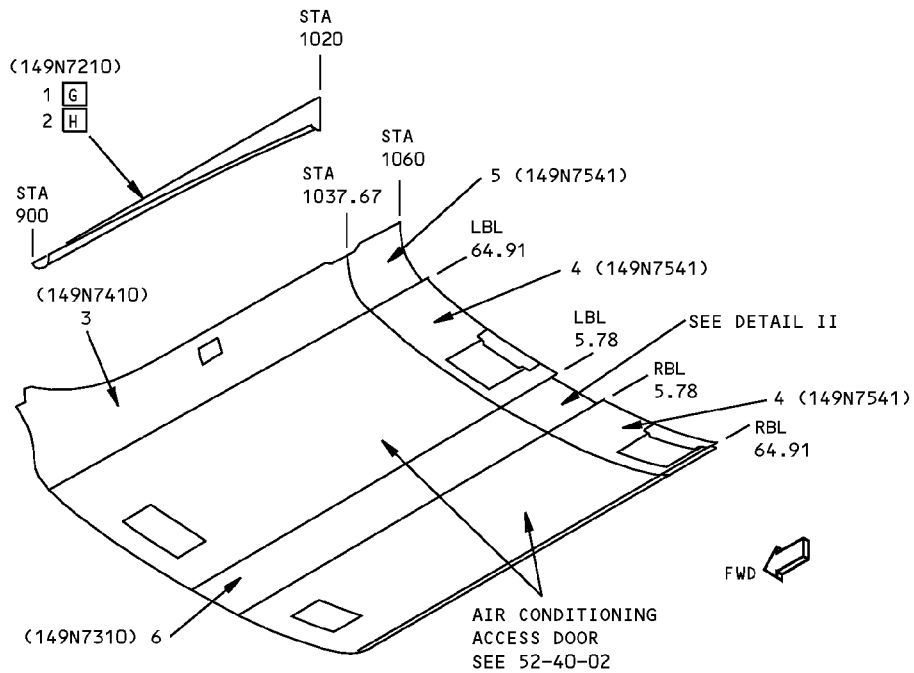
NOTES

- | | |
|---|--|
| <p>A PLY ORIENTATION CONVENTION, DEGREES INDICATED, IS PARALLEL TO THE FABRIC WARP DIRECTION</p> <p>B MATERIAL AND PLY ORIENTATION SHOWN FOR FIELD AREAS ONLY. SEE BOEING DRAWING FOR EDGE BANDS AND AREAS WITH DOUBLERS</p> <p>C DIAGRAM OF PLY ORIENTATION. SEE PLY TABLE FOR INDIVIDUAL PLY ORIENTATION AND MATERIAL</p> <p>D ARAMID/EPOXY FABRIC PER BMS 8-219, STYLE 120, 250°F (121°C) CURE</p> <p>E GRAPHITE/EPOXY TAPE PER BMS 8-168, TYPE II, CLASS I, GRADE 145, 250°F (121°C) CURE</p> <p>F GRAPHITE/EPOXY FABRIC PER BMS 8-168, TYPE II, CLASS II, STYLE 3K-70-PW, 250°F (121°C) CURE</p> <p>G FOR CUM LINE NUMBER:
1</p> <p>H FOR CUM LINE NUMBERS:
2 AND ON</p> <p>I GRAPHITE/EPOXY TAPE PER BMS 8-168, TYPE II, CLASS I, GRADE 190, 250°F (121°C) CURE</p> <p>J THORSTRAND TEFA-60-F155</p> <p>K ARAMID/EPOXY FABRIC PER BMS 8-219, STYLE 285, 250°F (121°C) CURE</p> <p>L ALUMINIZED FIBERGLASS PREPREG PER BMS 8-278, TYPE II, CLASS 250, 250°F (121°C) CURE</p> <p>M FIBERGLASS/EPOXY FABRIC PER BMS 8-79, STYLE 120, CLASS III, GRADE B, 250°F (121°C) CURE</p> | <p>N THORSTRAND TEFA-60-F161</p> <p>O ARAMID/EPOXY FABRIC PER BMS 8-218, STYLE 285, 350°F (177°C) CURE</p> <p>P GRAPHITE/EPOXY TAPE PER BMS 8-212, TYPE III, CLASS I, GRADE 145, 350°F (177°C) CURE</p> <p>Q GRAPHITE/EPOXY FABRIC PER BMS 8-212, TYPE IV, CLASS II, STYLE 3K-70-PW, 350°F (177°C) CURE</p> <p>R OPTIONAL FOR P19 FOR CUM LINE NUMBERS:
1 THRU 9</p> <p>S OPTIONAL FOR P31 FOR CUM LINE NUMBERS:
1 THRU 9</p> <p>T FOR CUM LINE NUMBERS:
1 THRU 42</p> <p>U FOR CUM LINE NUMBERS:
1 THRU 1029</p> <p>V FOR CUM LINE NUMBERS:
1041, 1044 THRU 1050</p> <p>W FIBERGLASS/EPOXY FABRIC PER BMS 8-79, STYLE 1581, CLASS III, GRADE B, 250°F (121°C) CURE</p> <p>X FIBERGLASS/EPOXY FABRIC PER BMS 8-139, STYLE 1581, CLASS 1, 350°F (177°C) CURE</p> <p>Y ALUMINUM FOIL PER BMS 8-336, TYPE I, CLASS 1, GRADE D16, FORM A</p> <p>Z FOR CUM LINE NUMBERS:
1 THRU 814</p> <p>AA FOR CUM LINE NUMBERS:
815 THRU 1050</p> |
|---|--|

**Section 44 Wing-to-Body Fairing Skin Identification
Figure 1 (Sheet 1 of 18)**

757-200
STRUCTURAL REPAIR MANUAL

REF DWG
149N7501



LEFT SIDE SHOWN
RIGHT SIDE OPPOSITE

DETAIL I



Section 44 Wing-to-Body Fairing Skin Identification
Figure 1 (Sheet 2 of 18)

IDENTIFICATION 1
Page 2
May 20/2007

53-40-70

D634N201



**757-200
STRUCTURAL REPAIR MANUAL**

ITEM	DESCRIPTION	GAGE	MATERIAL	EFFECTIVITY				
1	SKIN PANEL SKIN PANEL SKIN CORE		ARAMID/GRAPHITE/EPOXY HONEYCOMB SANDWICH, FIBERGLASS/GRAPHITE/EPOXY HONEYCOMB SANDWICH, SEE DETAIL III ARAMID HONEYCOMB PER BMS 8-124, CLASS 4, TYPE V, GRADE 3.0	<table border="1"><tr><td>G</td><td>U</td></tr><tr><td>V</td><td></td></tr></table>	G	U	V	
G	U							
V								
2	SKIN PANEL SKIN PANEL SKIN CORE		ARAMID/GRAPHITE/EPOXY HONEYCOMB SANDWICH, FIBERGLASS/GRAPHITE/EPOXY HONEYCOMB SANDWICH, SEE DETAIL III ARAMID HONEYCOMB PER BMS 8-124, CLASS 1, TYPE I, GRADE 8.0	<table border="1"><tr><td>H</td><td>U</td></tr><tr><td>V</td><td></td></tr></table>	H	U	V	
H	U							
V								
3	SKIN PANEL SKIN PANEL SKIN CORE		ARAMID/GRAPHITE/EPOXY HONEYCOMB SANDWICH, FIBERGLASS/GRAPHITE/EPOXY HONEYCOMB SANDWICH, SEE DETAIL IV ARAMID HONEYCOMB PER BMS 8-124, CLASS 4, TYPE V, GRADE 3.0	<table border="1"><tr><td>U</td><td></td></tr><tr><td>V</td><td></td></tr></table>	U		V	
U								
V								
4	SKIN PANEL SKIN PANEL SKIN CORE		ARAMID/GRAPHITE/EPOXY HONEYCOMB SANDWICH, FIBERGLASS/GRAPHITE/EPOXY HONEYCOMB SANDWICH, SEE DETAIL V PHENOLIC HONEYCOMB PER BMS 8-124, CLASS 1, TYPE I, GRADE 4.0	<table border="1"><tr><td>U</td><td></td></tr><tr><td>V</td><td></td></tr></table>	U		V	
U								
V								
5	SKIN PANEL SKIN PANEL SKIN CORE		ARAMID/GRAPHITE/EPOXY HONEYCOMB SANDWICH, FIBERGLASS/GRAPHITE/EPOXY HONEYCOMB SANDWICH, SEE DETAIL V ARAMID HONEYCOMB PER BMS 8-124, CLASS 4, TYPE V, GRADE 3.0	<table border="1"><tr><td>U</td><td></td></tr><tr><td>V</td><td></td></tr></table>	U		V	
U								
V								
6	SKIN PANEL SKIN PANEL SKIN CORE		ARAMID/GRAPHITE/EPOXY HONEYCOMB SANDWICH, FIBERGLASS/GRAPHITE/EPOXY HONEYCOMB SANDWICH, SEE DETAIL VI ARAMID HONEYCOMB PER BMS 8-124, CLASS 4, TYPE V, GRADE 3.0	<table border="1"><tr><td>U</td><td></td></tr><tr><td>V</td><td></td></tr></table>	U		V	
U								
V								

LIST OF MATERIALS FOR DETAIL I

**Section 44 Wing-to-Body Fairing Skin Identification
Figure 1 (Sheet 3 of 18)**

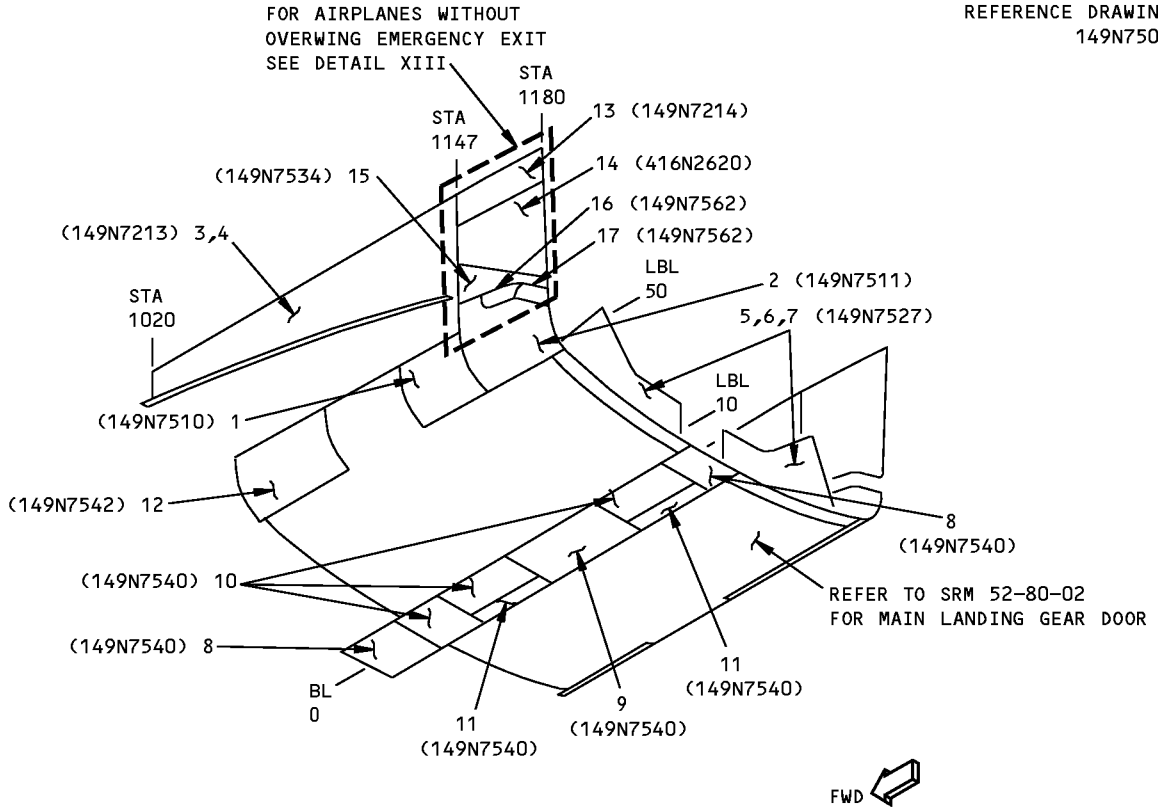
D634N201

53-40-70

IDENTIFICATION 1
Page 3
May 20/2007

**757-200
STRUCTURAL REPAIR MANUAL**

REFERENCE DRAWING
149N7501



LEFT SIDE IS SHOWN,
RIGHT SIDE IS OPPOSITE

DETAIL II

ITEM	DESCRIPTION	GAGE	MATERIAL	EFFECTIVITY		
1	SKIN PANEL SKIN PANEL SKIN CORE		ARAMID/GRAPHITE/EPOXY HONEYCOMB SANDWICH, FIBERGLASS/GRAPHITE/EPOXY HONEYCOMB SANDWICH, SEE DETAIL VII ARAMID HONEYCOMB PER BMS 8-124, CLASS 4, TYPE V, GRADE 3.0	<table border="1"><tr><td>Z</td></tr><tr><td>AA</td></tr></table>	Z	AA
Z						
AA						
2	SKIN PANEL SKIN PANEL SKIN CORE		ARAMID/GRAPHITE/EPOXY HONEYCOMB SANDWICH, FIBERGLASS/GRAPHITE/EPOXY HONEYCOMB SANDWICH, SEE DETAIL VIII ARAMID HONEYCOMB PER BMS 8-124, CLASS 4, TYPE V, GRADE 3.0	<table border="1"><tr><td>U</td></tr><tr><td>V</td></tr></table>	U	V
U						
V						
3	SKIN PANEL SKIN PANEL SKIN CORE		ARAMID/GRAPHITE/EPOXY HONEYCOMB SANDWICH, FIBERGLASS/GRAPHITE/EPOXY HONEYCOMB SANDWICH, SEE DETAIL IX ARAMID HONEYCOMB PER BMS 8-124, CLASS 4, TYPE V, GRADE 3.0	<table border="1"><tr><td>U</td></tr><tr><td>V</td></tr></table>	U	V
U						
V						

LIST OF MATERIALS FOR DETAIL II

**Section 44 Wing-to-Body Fairing Skin Identification
Figure 1 (Sheet 4 of 18)**

IDENTIFICATION 1
Page 4
May 20/2007

53-40-70

D634N201



757-200

STRUCTURAL REPAIR MANUAL

ITEM	DESCRIPTION	GAGE	MATERIAL	EFFECTIVITY
4	SKIN PANEL SKIN PANEL SKIN CORE		ARAMID/GRAPHITE EPOXY HONEYCOMB SANDWICH, FIBERGLASS/GRAPHITE EPOXY HONEYCOMB SANDWICH, SEE DETAIL IX ARAMID HONEYCOMB PER BMS 8-124, CLASS 4, TYPE V, GRADE 5.0	U V
5	SKIN PANEL SKIN PANEL SKIN CORE		ARAMID/GRAPHITE EPOXY HONEYCOMB SANDWICH, FIBERGLASS/GRAPHITE EPOXY HONEYCOMB SANDWICH, SEE DETAIL X ARAMID HONEYCOMB PER BMS 8-124, CLASS 4, TYPE V, GRADE 3.0	U V
6	SKIN PANEL SKIN PANEL SKIN CORE		ARAMID/GRAPHITE EPOXY HONEYCOMB SANDWICH, FIBERGLASS/GRAPHITE EPOXY HONEYCOMB SANDWICH, SEE DETAIL X HEXCEL FLEX HONEYCOMB HRH-101F50-4.5	U V
7	SKIN PANEL SKIN PANEL SKIN CORE		ARAMID/GRAPHITE EPOXY HONEYCOMB SANDWICH, FIBERGLASS/GRAPHITE EPOXY HONEYCOMB SANDWICH, SEE DETAIL X ARAMID HONEYCOMB PER BMS 8-124, CLASS 4, TYPE VI, GRADE 3.0	U V
8	SKIN PANEL SKIN PANEL SKIN		ARAMID/GRAPHITE EPOXY LAMINATE FIBERGLASS/GRAPHITE EPOXY LAMINATE SEE DETAIL XI	U V
9	SKIN PANEL SKIN PANEL SKIN CORE		ARAMID/GRAPHITE EPOXY HONEYCOMB SANDWICH, FIBERGLASS/GRAPHITE EPOXY HONEYCOMB SANDWICH, SEE DETAIL XI ARAMID HONEYCOMB PER BMS 8-124, CLASS 4, TYPE V, GRADE 3.0	U V
10	SKIN PANEL SKIN PANEL SKIN CORE		ARAMID/GRAPHITE EPOXY HONEYCOMB SANDWICH, FIBERGLASS/GRAPHITE EPOXY HONEYCOMB SANDWICH, SEE DETAIL XI ARAMID HONEYCOMB PER BMS 8-124, CLASS 4, TYPE V, GRADE 3.0	U V
11	SKIN PANEL SKIN PANEL		ARAMID/GRAPHITE EPOXY LAMINATE FIBERGLASS/GRAPHITE EPOXY LAMINATE SEE DETAIL XI	U V
12	SKIN PANEL SKIN PANEL SKIN CORE		ARAMID/GRAPHITE EPOXY HONEYCOMB SANDWICH, FIBERGLASS/GRAPHITE EPOXY HONEYCOMB SANDWICH, SEE DETAIL XII ARAMID HONEYCOMB PER BMS 8-124, CLASS 4, TYPE V, GRADE 3.0	U V
13	SKIN PANEL SKIN PANEL SKIN CORE		ARAMID/GRAPHITE EPOXY HONEYCOMB SANDWICH, FIBERGLASS/GRAPHITE EPOXY HONEYCOMB SANDWICH, SEE DETAIL XIV ARAMID HONEYCOMB PER BMS 8-124, CLASS 4, TYPE V, GRADE 3.0	U V
14	ESCAPE SLIDE DOOR ESCAPE SLIDE DOOR SKIN CORE		ARAMID/GRAPHITE EPOXY HONEYCOMB SANDWICH, FIBERGLASS/GRAPHITE EPOXY HONEYCOMB SANDWICH, SEE DETAIL XIV ARAMID HONEYCOMB PER BMS 8-124 CLASS 4, TYPE V, GRADE 4.0	U V

LIST OF MATERIALS FOR DETAIL II (CONT)

Section 44 Wing-to-Body Fairing Skin Identification
Figure 1 (Sheet 5 of 18)

IDENTIFICATION 1
Page 5
May 20/2007

53-40-70

D634N201



757-200
STRUCTURAL REPAIR MANUAL

ITEM	DESCRIPTION	GAGE	MATERIAL	EFFECTIVITY		
15	SKIN PANEL SKIN PANEL		ARAMID/FIBERGLASS EPOXY LAMINATE FIBERGLASS EPOXY LAMINATE SEE DETAIL XIV	<table border="1"><tr><td>U</td></tr><tr><td>V</td></tr></table>	U	V
U						
V						
16	FORWARD DOOR - MAIN FLAP TORQUE TUBE SLOT	0.125	7075-T6 BARE ALUMINUM SHEET			
17	AFT DOOR - MAIN FLAP TORQUE TUBE SLOT	0.125	7075-T6 BARE ALUMINUM SHEET			

LIST OF MATERIALS FOR DETAIL II (CONT)

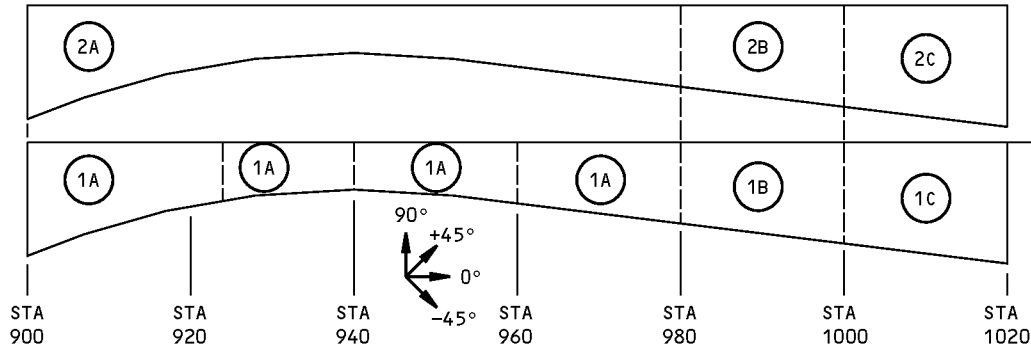
Section 44 Wing-to-Body Fairing Skin Identification
Figure 1 (Sheet 6 of 18)

D634N201

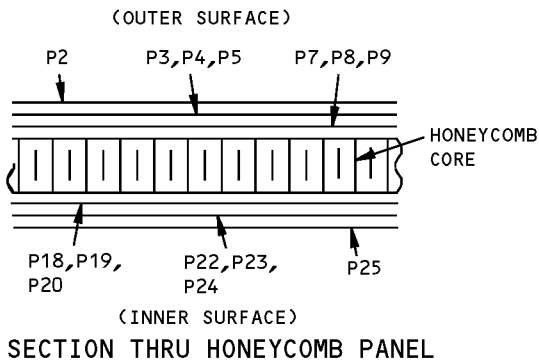
53-40-70

IDENTIFICATION 1
Page 6
Sep 20/2007

**757-200
STRUCTURAL REPAIR MANUAL**



VIEW ON PANEL **C**
REFER TO DETAIL I



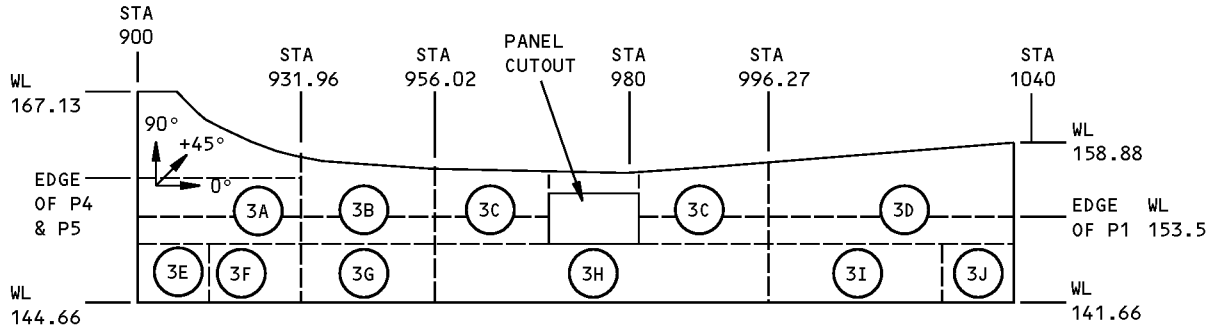
ITEM NO.	PLY NO.	MATERIAL	PLY ORIENTATION ^A
1	1A	P2, P25	$\begin{matrix} \text{U} & \text{D} \\ \text{V} & \text{W} \end{matrix}$ / 0° OR 90°
		P3, P22	E / 0°
		P7, P18	F / 0° OR 90°
	1B	P2, P25	$\begin{matrix} \text{U} & \text{D} \\ \text{V} & \text{W} \end{matrix}$ / 0° OR 90°
		P4, P23	E / 0°
		P8, P19	F / 0° OR 90°
	1C	P2, P25	$\begin{matrix} \text{U} & \text{D} \\ \text{V} & \text{W} \end{matrix}$ / 0° OR 90°
		P5, P24	E / 0°
		P9, P20	F / 0° OR 90°
2	2A	P2, P25	$\begin{matrix} \text{U} & \text{D} \\ \text{V} & \text{W} \end{matrix}$ / 0° OR 90°
		P3, P22	E / 0°
		P7, P8	F / 0° OR 90°
	2B	P2, P25	$\begin{matrix} \text{U} & \text{D} \\ \text{V} & \text{W} \end{matrix}$ / 0° OR 90°
		P4, P23	E / 0°
		P8, P19	F / 0° OR 90°
	2C	P2, P25	$\begin{matrix} \text{U} & \text{D} \\ \text{V} & \text{W} \end{matrix}$ / 0° OR 90°
		P5, P24	E / 0°
		P9, P20	F / 0° OR 90°

PLY TABLE **B**

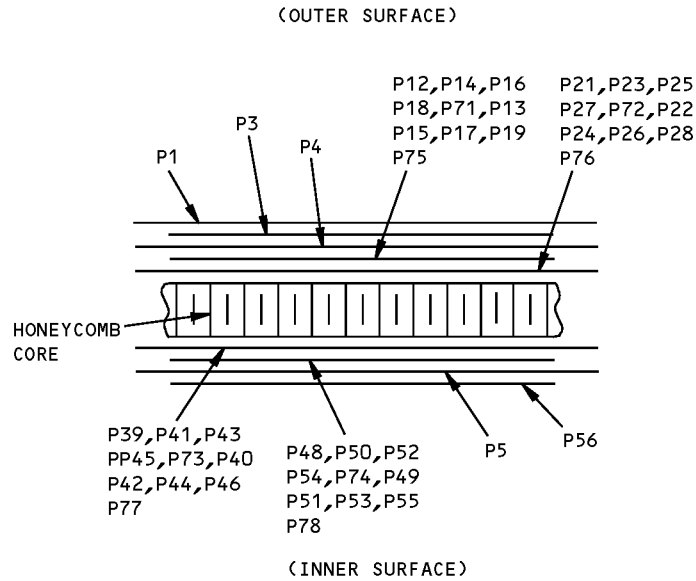
DETAIL III

**Section 44 Wing-to-Body Fairing Skin Identification
Figure 1 (Sheet 7 of 18)**

**757-200
STRUCTURAL REPAIR MANUAL**



VIEW ON PANEL C
REFER TO DETAIL I



**SECTION THRU HONEYCOMB PANELS
DETAIL IV**

**Section 44 Wing-to-Body Fairing Skin Identification
Figure 1 (Sheet 8 of 18)**

**757-200
STRUCTURAL REPAIR MANUAL**

ITEM NO.	PLY NO.	MATERIAL	PLY ORIENTATION ^A
3	3A	P1	T L 0° OR 90°
		P3,P56	U D 0° OR 90°
			V W
		P4,P5	I 90°
	P12,P48 P21,P39	F 0° OR 90°	
	3B	P1	T L 0° OR 90°
		P3,P56	U D 0° OR 90°
			V W
		P14,P50 P23,P41	F 0° OR 90°
	3C	P1	T L 0° OR 90°
		P3,P56	U D 0° OR 90°
			V W
P16,P52 P25,P43		F 0° OR 90°	
3D	P1	T L 0° OR 90°	
	P3,P56	U D 0° OR 90°	
		V W	
	P18,P54 P27,P45	F 0° OR 90°	
3E	P1	T L 0° OR 90°	
	P3,P56	U D 0° OR 90°	
		V W	
	P71,P74 P72,P73	F 0° OR 90°	
3F	P1	T L 0° OR 90°	
	P3,P56	U D 0° OR 90°	
		V W	
	P13,P49 P22,P40	F 0° OR 90°	
3G	P1	T L 0° OR 90°	
	P3,P56	U D 0° OR 90°	
		V W	
	P15,P51 P24,P42	F 0° OR 90°	
3H	P1	T L 0° OR 90°	
	P3,P56	U D 0° OR 90°	
		V W	
	P17,P53 P26,P44	F 0° OR 90°	

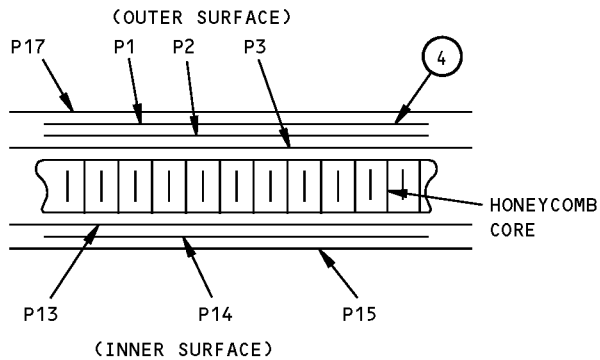
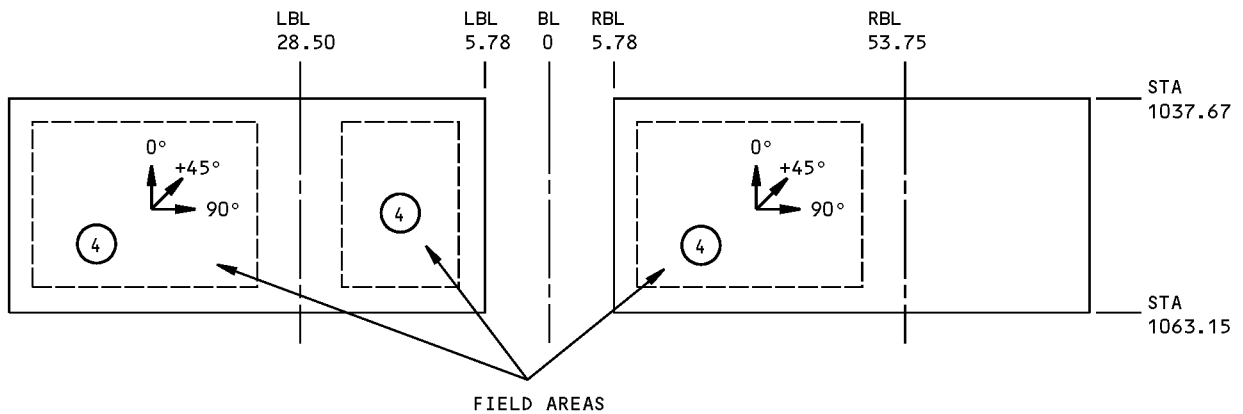
ITEM NO.	PLY NO.	MATERIAL	PLY ORIENTATION ^A
3	3I	P1	T L 0° OR 90°
		P3,P56	U D 0° OR 90°
			V W
	P19,P55 P28,P46	F 0° OR 90°	
	3J	P1	T L 0° OR 90°
		P3,P56	U D 0° OR 90°
V W			
P75,P78 P76,P77	F 0° OR 90°		

PLY TABLE ^B

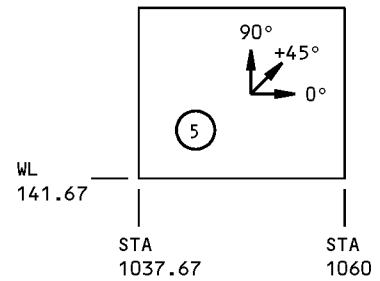
DETAIL IV (CONT)

**Section 44 Wing-to-Body Fairing Skin Identification
Figure 1 (Sheet 9 of 18)**

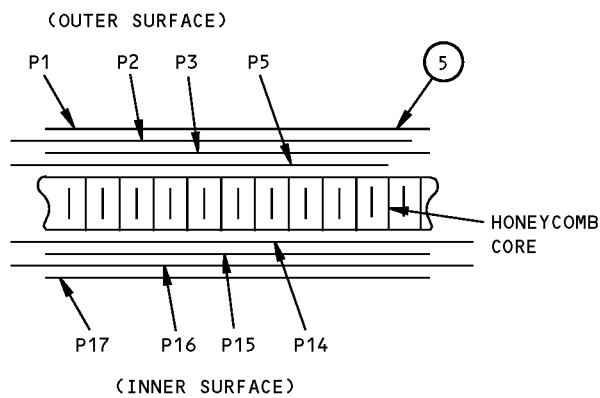
757-200 STRUCTURAL REPAIR MANUAL



SECTION THRU HONEYCOMB PANELS



VIEW ON PANELS **C**
REFER TO DETAIL I



SECTION THRU HONEYCOMB PANEL

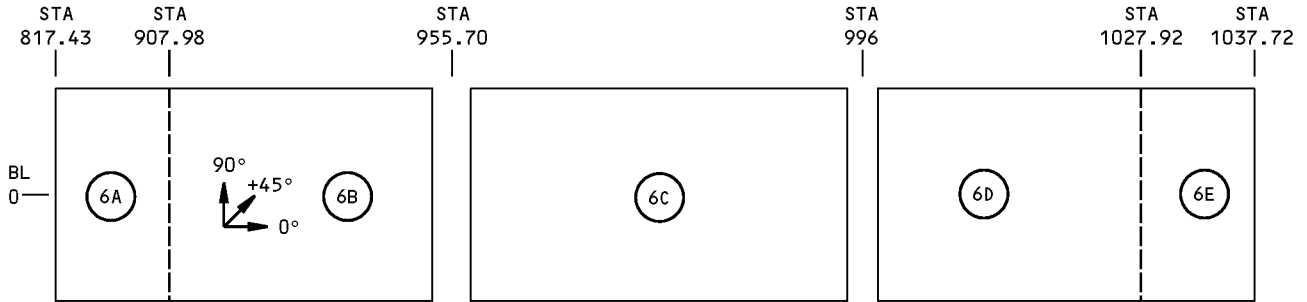
ITEM NO.	PLY NO.	MATERIAL	PLY ORIENTATION A
4	P17	T N	0° OR 90°
	P1, P15	U O	0° OR 90°
		V X	
	P2, P14	P	0°
P3, P13	Q	0° OR 90°	
5	P2, P17	U D	0° OR 90°
		V M	
	P1	T J	0° OR 90°
	P3, P16	E	0°
	P15	U K	0° OR 90°
		V X	
P14, P5	F	0° OR 90°	

PLY TABLE **B**

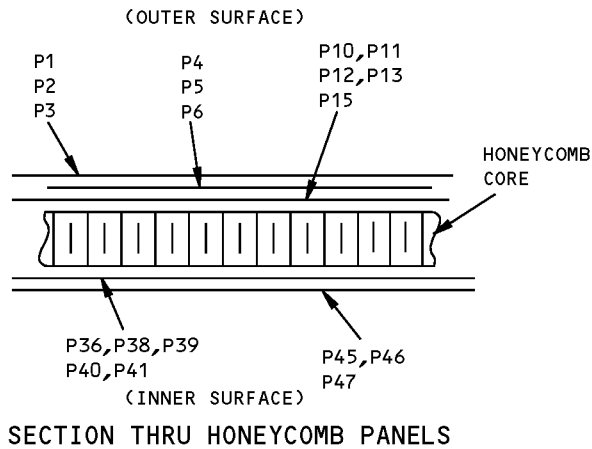
DETAIL V

Section 44 Wing-to-Body Fairing Skin Identification Figure 1 (Sheet 10 of 18)

**757-200
STRUCTURAL REPAIR MANUAL**



VIEW ON PANELS **C**
REFER TO DETAIL I

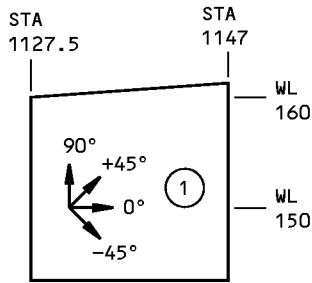


ITEM NO.	PLY NO.	MATERIAL	PLY ORIENTATION A
6	6A	P1	T J
		P4, P45	U K
		P13, P36	V W
	6B	P1	T J
		P4, P45	U K
		P10, P39	F
	6C	P2	T J
		P5, P46	U K
		P11, P40	F
	6D	P3	T J
		P6, P47	U K
		P12, P41	F
	6E	P3	T J
		P6, P47	U K
		P15, P38	V W
			0° OR 90°

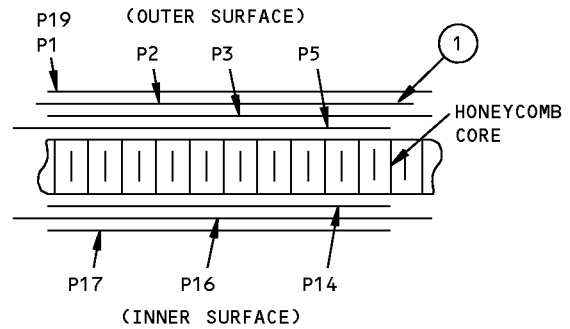
PLY TABLE **B**
DETAIL VI

**Section 44 Wing-to-Body Fairing Skin Identification
Figure 1 (Sheet 11 of 18)**

**757-200
STRUCTURAL REPAIR MANUAL**



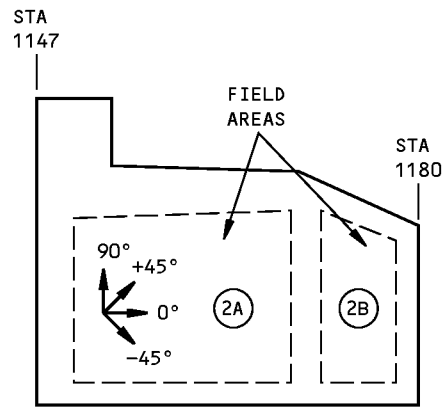
VIEW ON PANEL **C**
REFER TO DETAIL II



SECTION THRU HONEYCOMB PANEL
DETAIL VII

ITEM NO.	PLY NO.	MATERIAL	PLY ORIENTATION A
1	P1	T J	0° OR 90°
	P2, P17	Z D	0° OR 90°
		AA M	
	P3, P16	F	± 45°
	P5, P14	F	0° OR 90°
P19	R M	0° OR 90°	

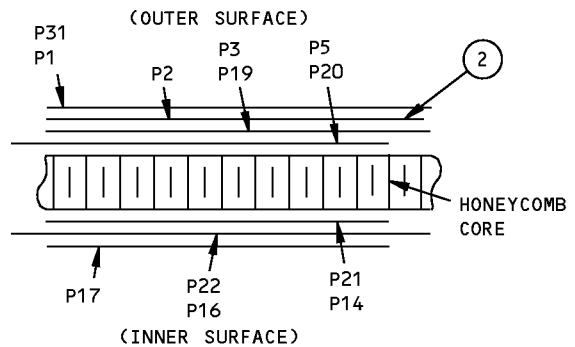
PLY TABLE **B**



VIEW ON PANEL **C**
REFER TO DETAIL II

ITEM NO.	PLY NO.	MATERIAL	PLY ORIENTATION A	
2	2A	P1	T J	0° OR 90°
		P2, P17	U D	0° OR 90°
			V M	
		P19, P22	F	± 45°
		P20, P21	F	0° OR 90°
	P31	M	0° OR 90°	
	2B	P1	T J	0° OR 90°
		P2, P17	U D	0° OR 90°
			V M	
		P3, P16	F	± 45°
P5, P14		F	0° OR 90°	
P31	S M	0° OR 90°		

PLY TABLE **C**

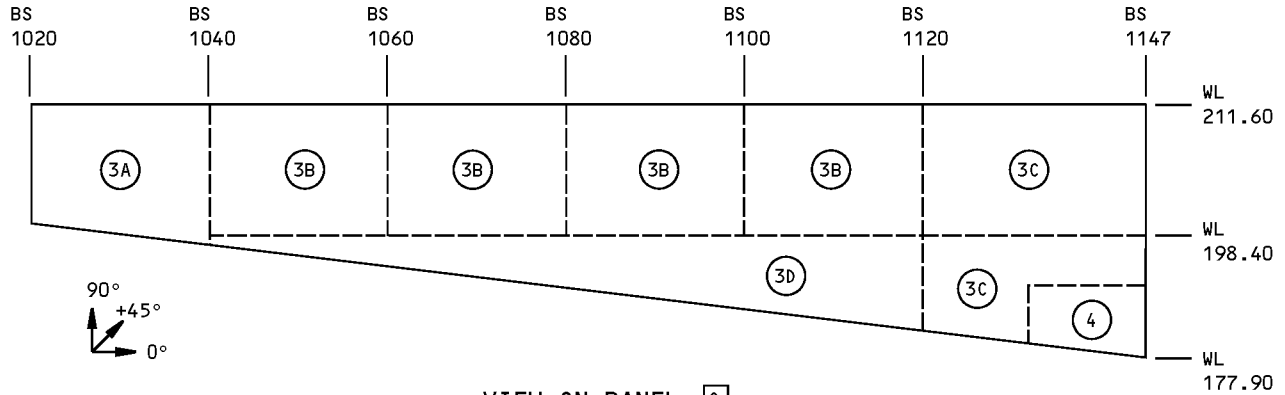


SECTION THRU HONEYCOMB PANEL

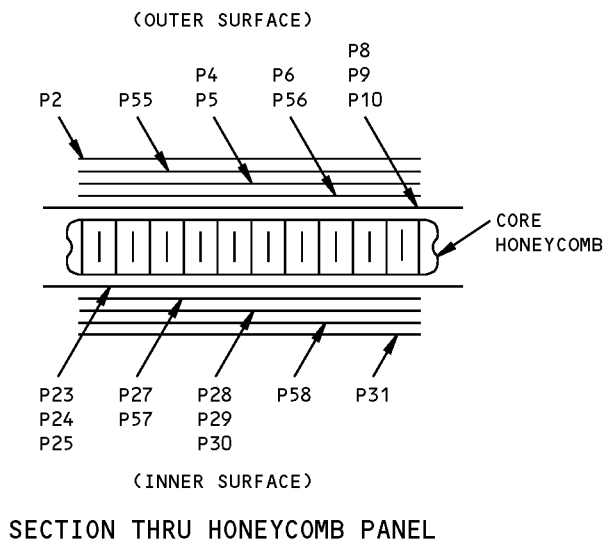
DETAIL VIII

**Section 44 Wing-to-Body Fairing Skin Identification
Figure 1 (Sheet 12 of 18)**

**757-200
STRUCTURAL REPAIR MANUAL**



VIEW ON PANEL **C**
REFER TO DETAIL II



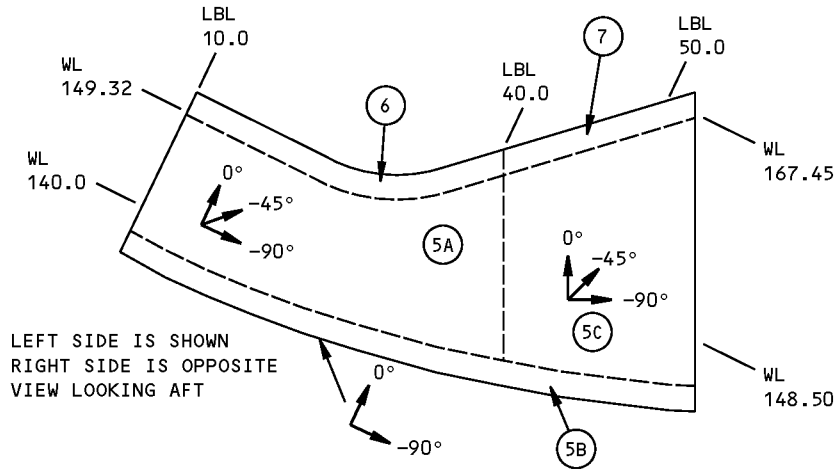
ITEM NO.	PLY NO.	MATERIAL	PLY ORIENTATION A	
3	3A	U D	0° OR 90°	
		V W		
		E	0°	
	3B	P2, P31	U D	0° OR 90°
			V W	
		E	0°	
		P9, P24	F	0° OR 90°
			F	
		3C	P2, P31	U D
	V W			
	E		0°	
	3D	P2, P31	U D	0° OR 90°
V W				
E		0°		
4	P2, P31	U D	0° OR 90°	
		V W		
	I	0°		
	F	0° OR 90°		

PLY TABLE **B**

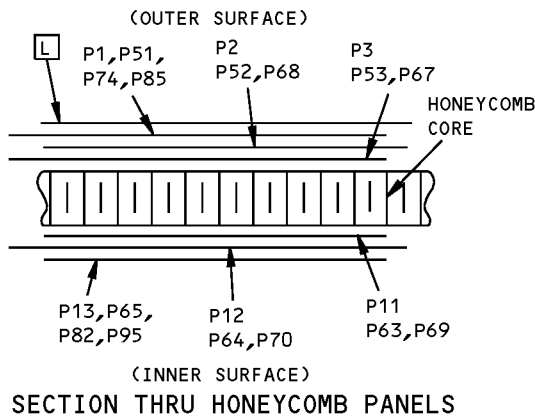
DETAIL IX

**Section 44 Wing-to-Body Fairing Skin Identification
Figure 1 (Sheet 13 of 18)**

**757-200
STRUCTURAL REPAIR MANUAL**



VIEW ON PANELS **C**
REFER TO DETAIL II



SECTION THRU HONEYCOMB PANELS

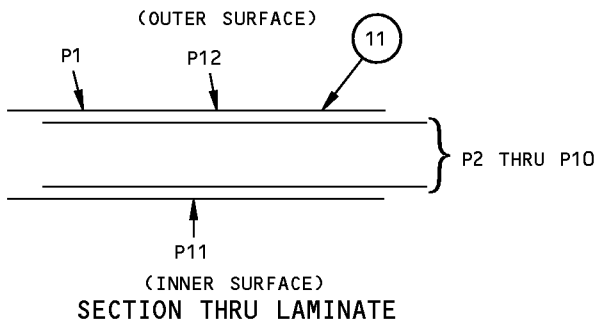
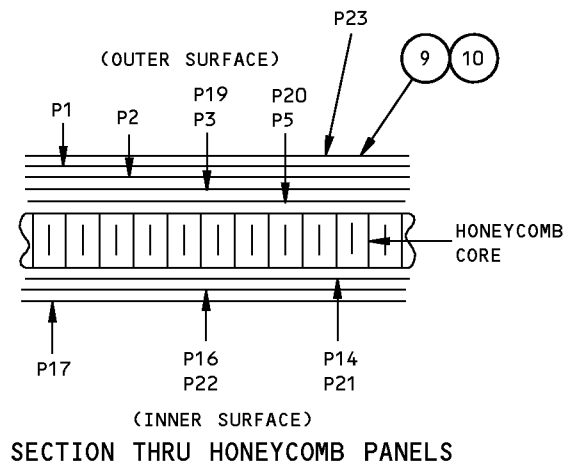
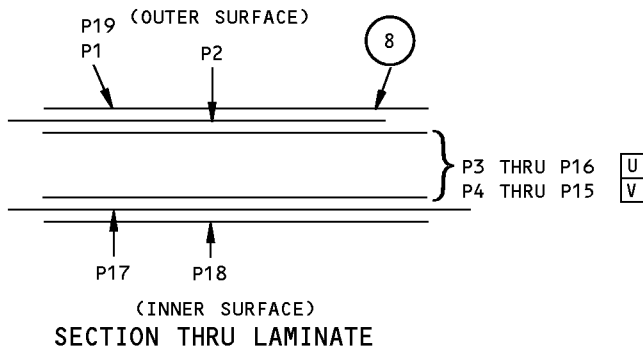
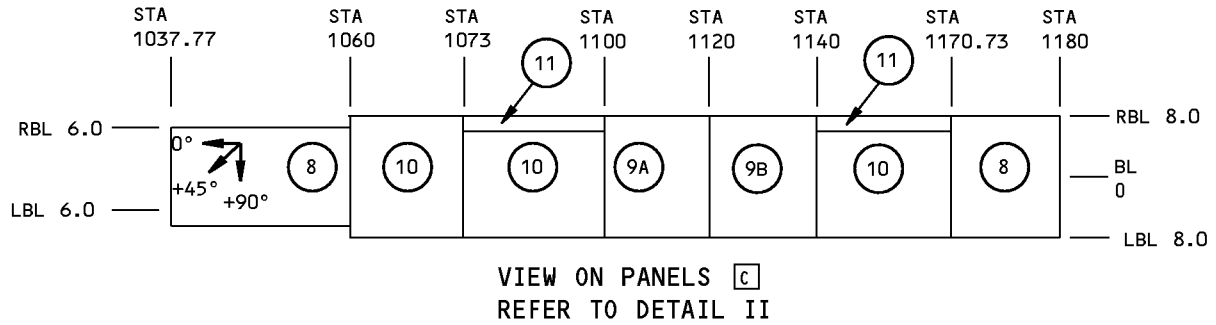
ITEM NO.	PLY NO.	MATERIAL	PLY ORIENTATION A
5	5A	U D	0° OR 90°
		V M	0° OR 90°
	P52, P64	F	± 45°
6	6	P53, P63	F
		P1, P13	U D
	5B	P74, P82	V M
7	5C	P2, P12	F
		P3, P11	F
	7	P51, P65	U D
		P85, P95	V M
		P68, P70	F
		P67, P69	F

PLY TABLE **B**

DETAIL X

**Section 44 Wing-to-Body Fairing Skin Identification
Figure 1 (Sheet 14 of 18)**

**757-200
STRUCTURAL REPAIR MANUAL**



DETAIL XI

**Section 44 Wing-to-Body Fairing Skin Identification
Figure 1 (Sheet 15 of 18)**



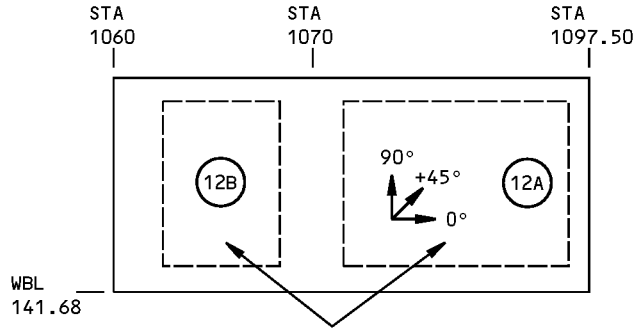
**757-200
STRUCTURAL REPAIR MANUAL**

ITEM NO.	PLY NO.	MATERIAL	PLY ORIENTATION A	
8	P1	T J	0° OR 90°	
	P19	V Y	-	
	P2,P17	U D	0° OR 90°	
		V M		
	P3 THRU P16	U K	OPTIONAL	
	P4 THRU P15	V W		
	P18	M	0° OR 90°	
9	9A	P1	T J	0° OR 90°
		P2,P17	U D	0° OR 90°
			V M	
		P3,P16	F	0° OR 90°
		P5,P14		
		P23	V Y	-
	9B	P1	T J	0° OR 90°
		P2,P17	U D	0° OR 90°
			V M	
		P19,P22	F	0° OR 90°
		P20,P21		
		P23	V Y	-
		10	P1	T J
	P2,P17		U D	0° OR 90°
V M				
P3,P5,P14,P16	F		0° OR 90°	
11	P1	T J	0° OR 90°	
	P2 THRU P10	U K	OPTIONAL	
		V W		
	P11	M	0° OR 90°	
	P12	V Y	-	

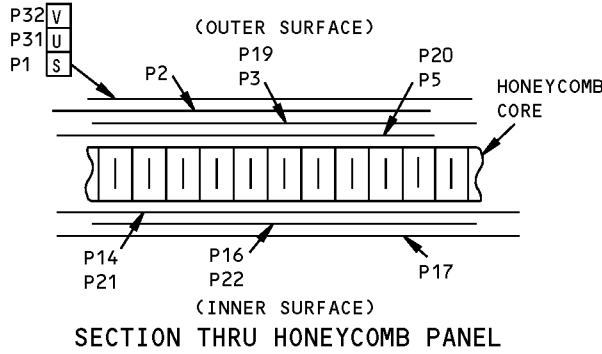
PLY TABLE B
DETAIL XI (CONT)

**Section 44 Wing-to-Body Fairing Skin Identification
Figure 1 (Sheet 16 of 18)**

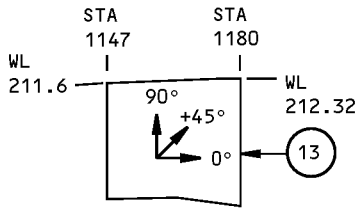
**757-200
STRUCTURAL REPAIR MANUAL**



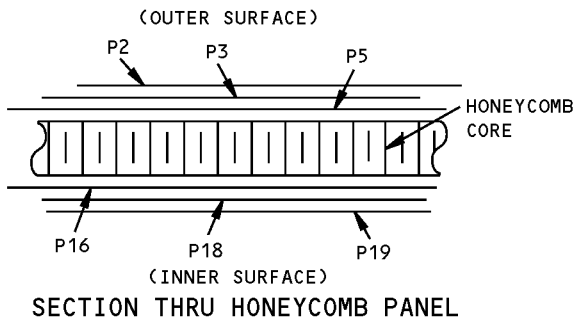
FIELD AREAS
VIEW ON PANELS **C**
REFER TO DETAIL II



DETAIL XII



VIEW ON PANELS **C**
REFER TO DETAIL II



DETAIL XIII

ITEM NO.	PLY NO.	MATERIAL	PLY ORIENTATION A
12	12A	P1	T J 0° OR 90°
		P2,P17	U D 0° OR 90°
			V M 0° OR 90°
		P3,P16	E 0°
		P5,P14	F 0° OR 90°
		P31	U M 0° OR 90°
	P32	V M 0° OR 90°	
	12B	P1	T J 0° OR 90°
		P2,P17	U D 0° OR 90°
			V M 0° OR 90°
		P19,P22	E 0°
		P20,P21	F 0° OR 90°
P31		U M 0° OR 90°	
P32	V M 0° OR 90°		

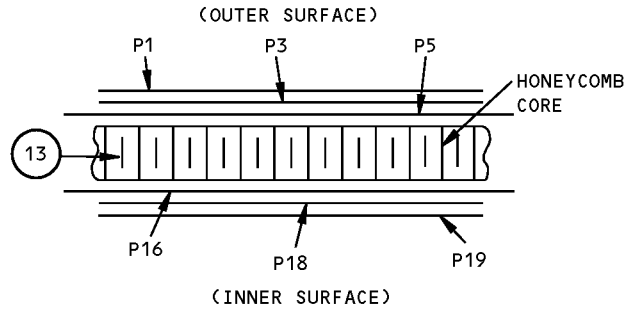
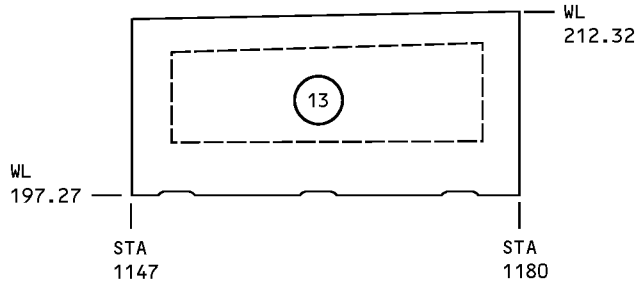
PLY TABLE **B**

ITEM NO.	PLY NO.	MATERIAL	PLY ORIENTATION A
13	P2,P19	U D 0° OR 90°	
		V M 0° OR 90°	
	P3,P18	E 0°	
P5,P16	F 0° OR 90°		

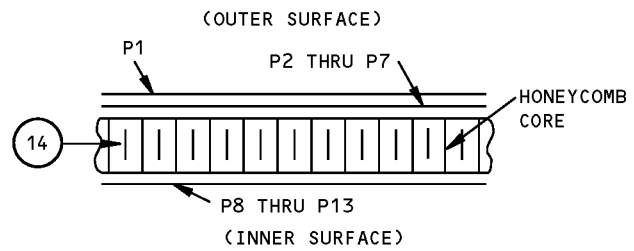
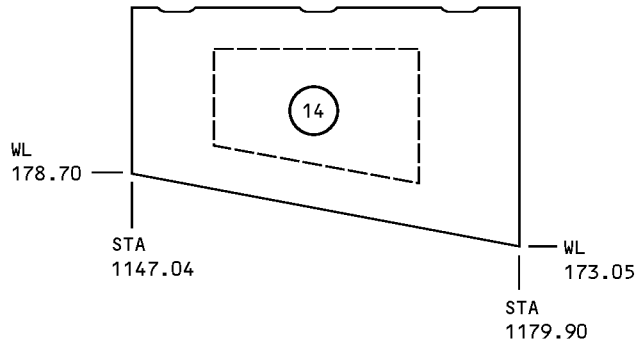
PLY TABLE **B**

**Section 44 Wing-to-Body Fairing Skin Identification
Figure 1 (Sheet 17 of 18)**

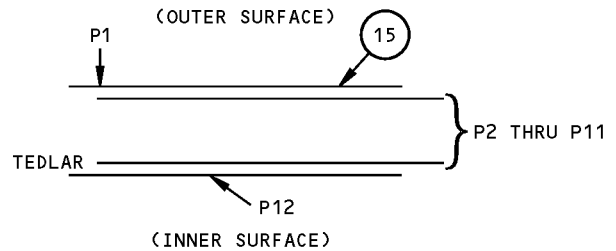
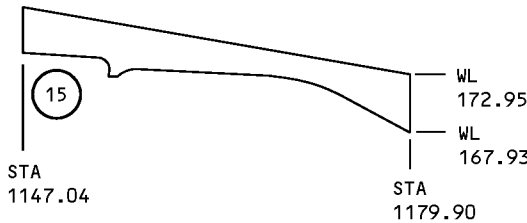
**757-200
STRUCTURAL REPAIR MANUAL**



SECTION THRU HONEYCOMB PANEL



SECTION THRU HONEYCOMB DOOR



SECTION THRU LAMINATE

ITEM NO.	PLY NO.	MATERIAL	PLY ORIENTATION ^A
13	P1	U K	0° OR 90°
		V M	
	P3,P18	E	0°
	P5,P16	F	0° OR 90°
P19		U D	0° OR 90°
		V M	
14	P1	U D	0° OR 90°
		V M	
	P2,P4,P6,P8,P10,P12	F	±45°
P3,P5,P7,P9,P11,P13	F	0° OR 90°	

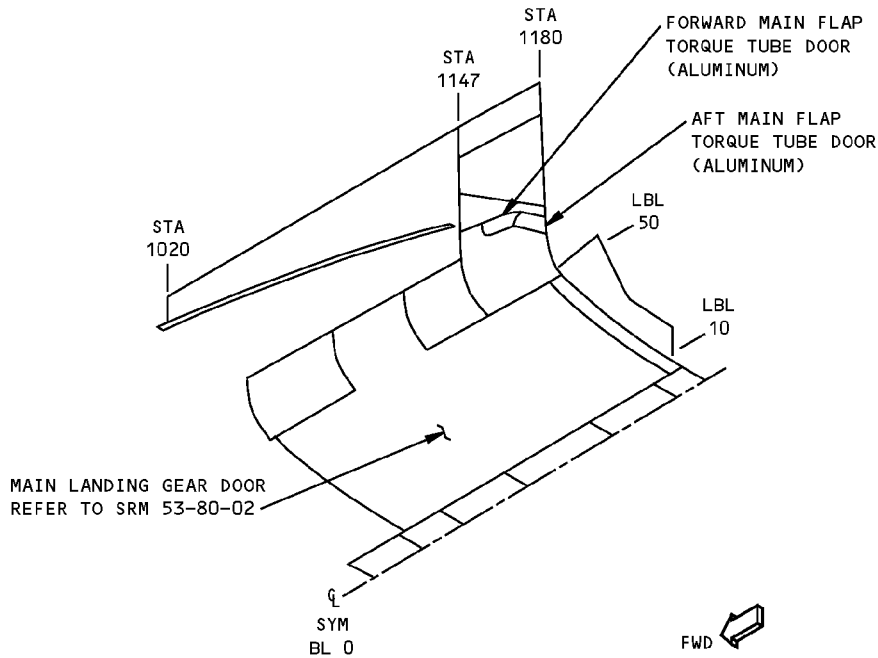
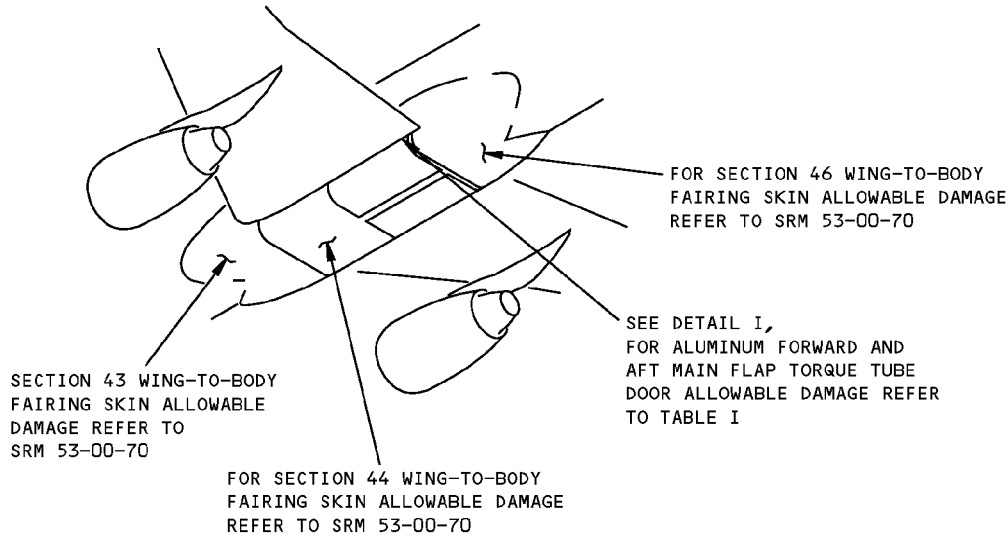
ITEM NO.	PLY NO.	MATERIAL	PLY ORIENTATION ^A
15	P1,P12	M	0° OR 90°
	P2,P3,P10,P11	U K	±45°
		V W	
P4,P5,P6,P7,P8,P9	U K	0° OR 90°	
		V W	

DETAIL XIV

**Section 44 Wing-to-Body Fairing Skin Identification
Figure 1 (Sheet 18 of 18)**

**757-200
STRUCTURAL REPAIR MANUAL**

ALLOWABLE DAMAGE GENERAL - SECTION 44 - WING-TO-BODY FAIRING TORQUE TUBE DOORS



LEFT SIDE IS SHOWN, RIGHT SIDE IS OPPOSITE

DETAIL I

**Section 44 Wing-to-Body Fairing Torque Tube Door Allowable Damage
Figure 101 (Sheet 1 of 4)**

**757-200
STRUCTURAL REPAIR MANUAL**

DESCRIPTION	CRACKS	NICKS, GOUGES AND CORROSION	DENTS	HOLES AND PUNCTURES
FOWARD MAIN FLAP TORQUE TUBE DOOR	A	B	SEE DETAIL IV	C
AFT MAIN FLAP TORQUE TUBE DOOR	A	B	SEE DETAIL IV	C

ALLOWABLE DAMAGE FOR DETAIL I
TABLE I

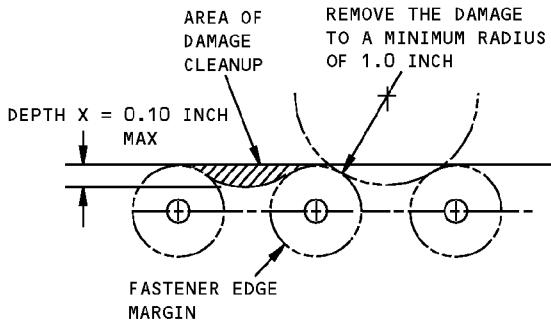
NOTES

- REFER TO AMM 51-20 FOR INTERNAL AND EXTERNAL FINISHES.
- REFER TO SRM 51-10-01 FOR AERODYNAMIC SMOOTHNESS REQUIREMENTS. IF THE DAMAGE IS LARGER THAN THE LIMITS GIVEN IN SRM 51-10-01, AERODYNAMIC PERFORMANCE WILL DECREASE.
- REFER TO SRM 51-10-02 FOR INSPECTION AND REMOVAL OF DAMAGE

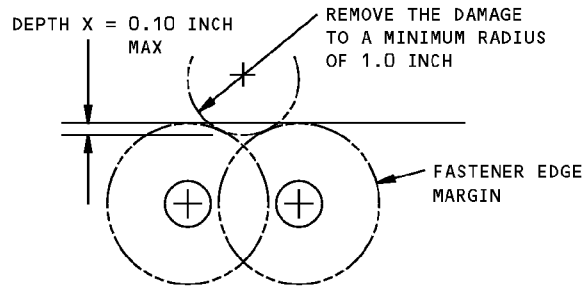
- A** EDGE CRACKS ARE PERMITTED. REMOVE EDGE CRACKS AS SHOWN IN DETAILS II AND VI. REPAIR ALL OTHER CRACKS AS SHOWN IN DETAIL VII.
- B** REMOVE THE DAMAGE AS SHOWN IN DETAILS II, III, V AND VI. YOU CAN DRILL OUT DAMAGE CAUSED BY CORROSION TO A MAXIMUM DIAMETER 0.50 INCH (12.7 mm) IF THE FASTENER EDGE MARGINS ARE KEPT. SEE DETAIL VII.
- C** REMOVE THE DAMAGE UP TO 0.25 INCH (6 mm) IN DIAMETER THAT IS NOT NEARER THAN 1.0 INCH (25 mm) TO A FASTENER HOLE, MATERIAL EDGE, OR OTHER DAMAGE. INSTALL A 2117-T3 OR T4 ALUMINUM RIVET IN THE HOLE WITH BMS 5-95 SEALANT. REPAIR ALL OTHER HOLES.

**Section 44 Wing-to-Body Fairing Torque Tube Door Allowable Damage
Figure 101 (Sheet 2 of 4)**

STRUCTURAL REPAIR MANUAL

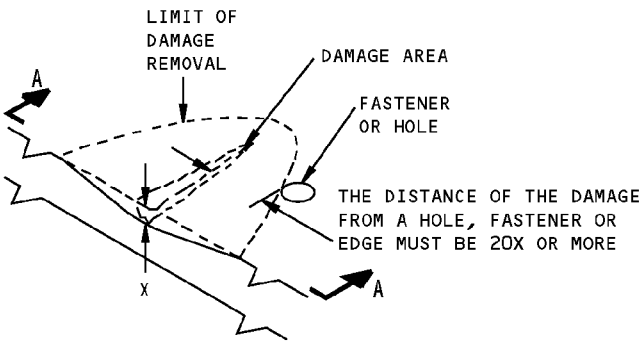


REMOVAL OF DAMAGE AT EDGES WHERE FASTENER EDGE MARGINS DO NOT OVERLAP

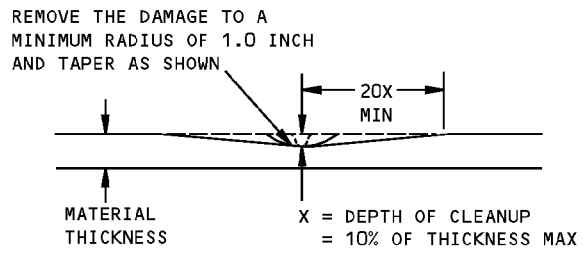


REMOVAL OF DAMAGE AT EDGES WHERE FASTENER EDGE MARGINS OVERLAP

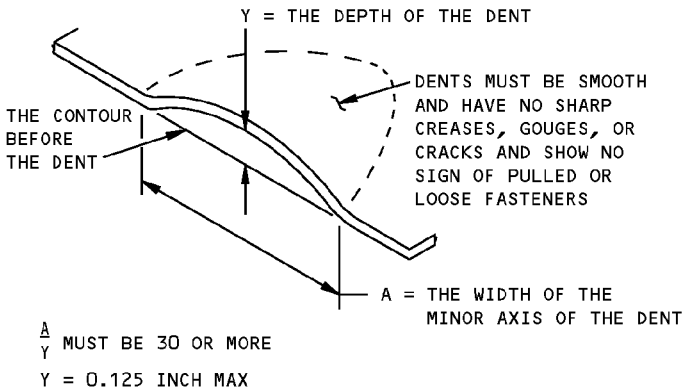
DETAIL II



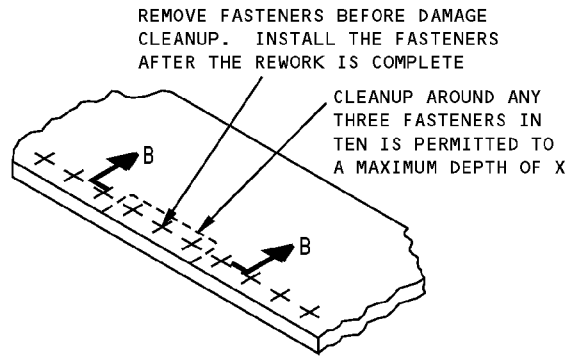
REMOVAL OF DAMAGE ON A SURFACE
DETAIL III



SECTION A-A



DENT DAMAGE PERMITTED
DETAIL IV



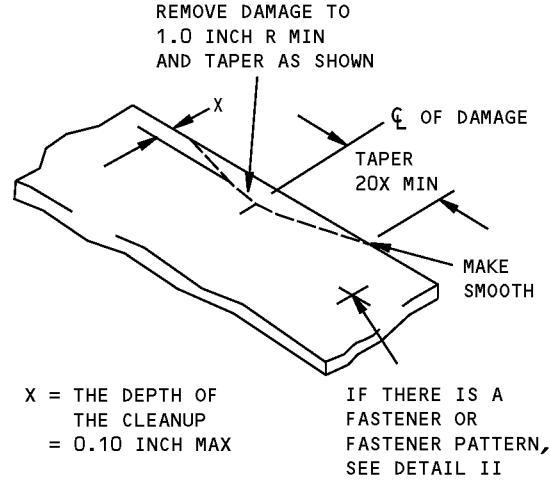
MAKE SMOOTH TO 0.5 INCH R MIN
X = THE DEPTH OF THE CLEANUP = 10% THICKNESS MAX

SECTION B-B

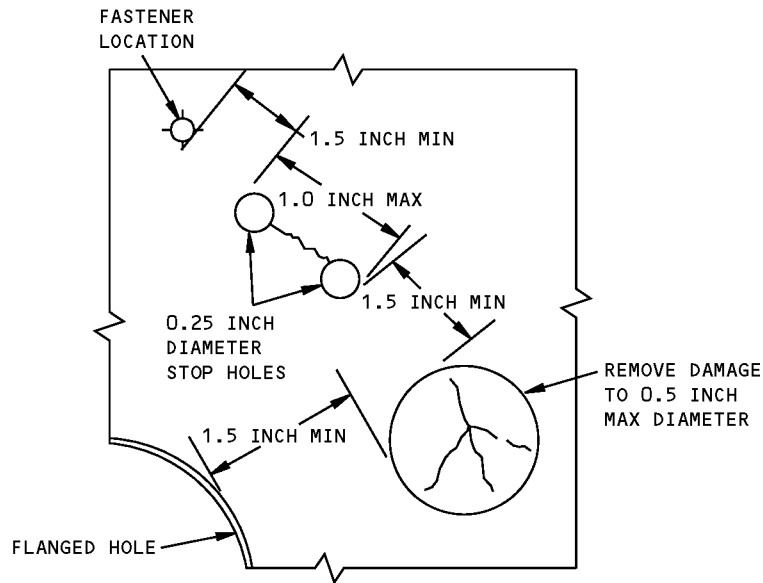
REMOVAL OF CORROSION DAMAGE
DETAIL V

**Section 44 Wing-to-Body Fairing Torque Tube Door Allowable Damage
Figure 101 (Sheet 3 of 4)**

STRUCTURAL REPAIR MANUAL



**REMOVAL OF DAMAGE ON AN EDGE
DETAIL VI**



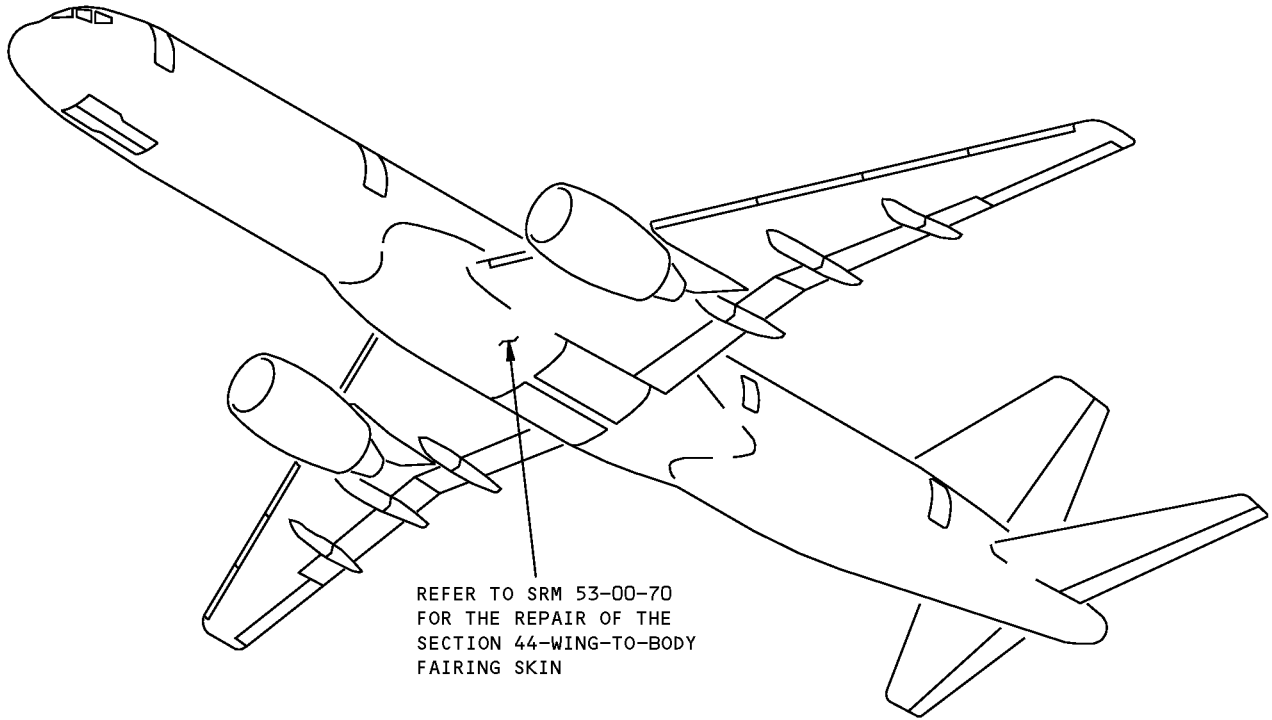
**CLEANUP OF CRACKS OR HOLES
DETAIL VII**

**Section 44 Wing-to-Body Fairing Torque Tube Door Allowable Damage
Figure 101 (Sheet 4 of 4)**



757-200
STRUCTURAL REPAIR MANUAL

REPAIR GENERAL - SECTION 44 - WING-TO-BODY FAIRING SKINS



Section 44 Wing-to-Body Fairing Skin Repairs
Figure 201

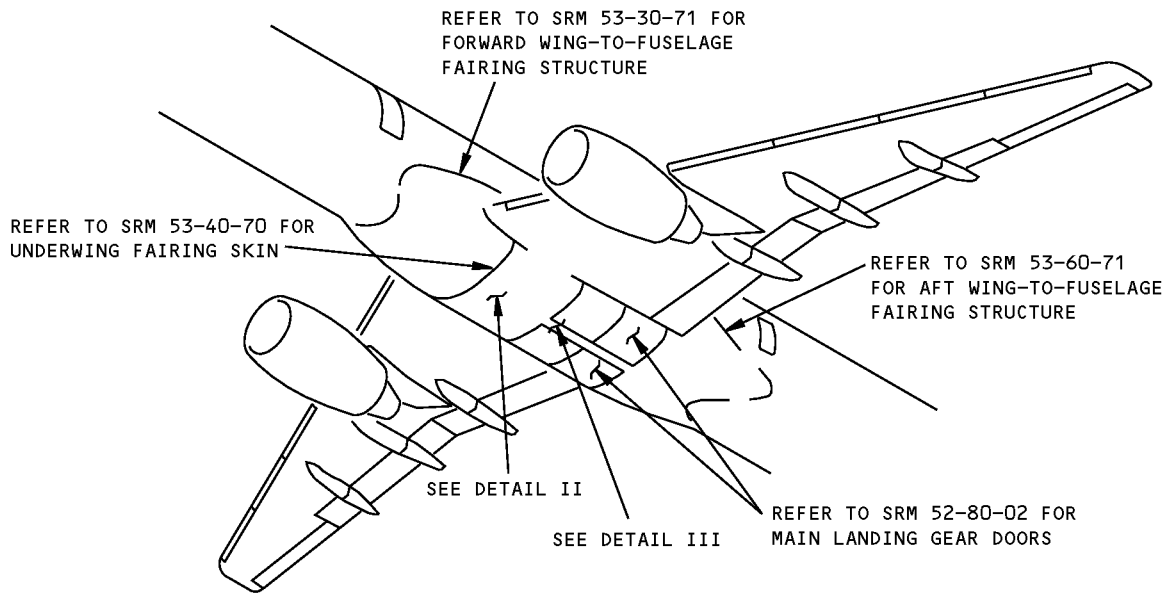
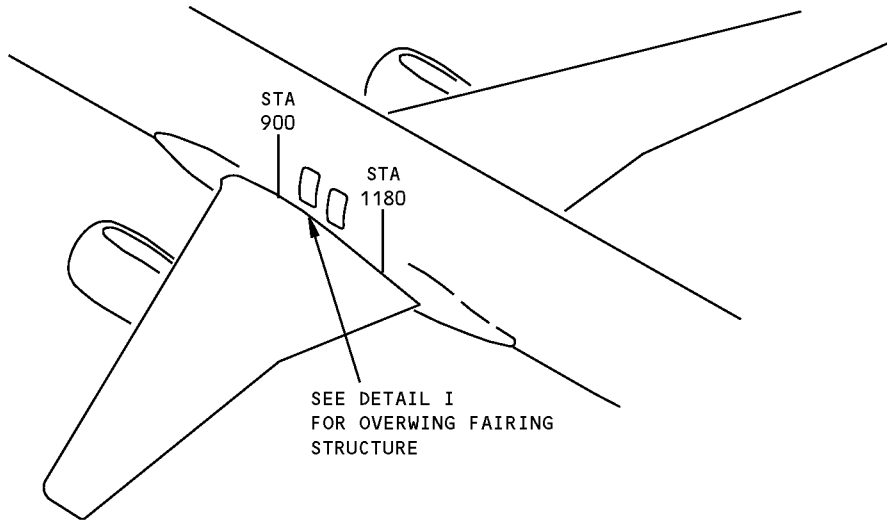
D634N201

53-40-70

REPAIR GENERAL
Page 201
Jan 20/2005

757-200
STRUCTURAL REPAIR MANUAL

IDENTIFICATION 1 - SECTION 44 - FAIRING STRUCTURE



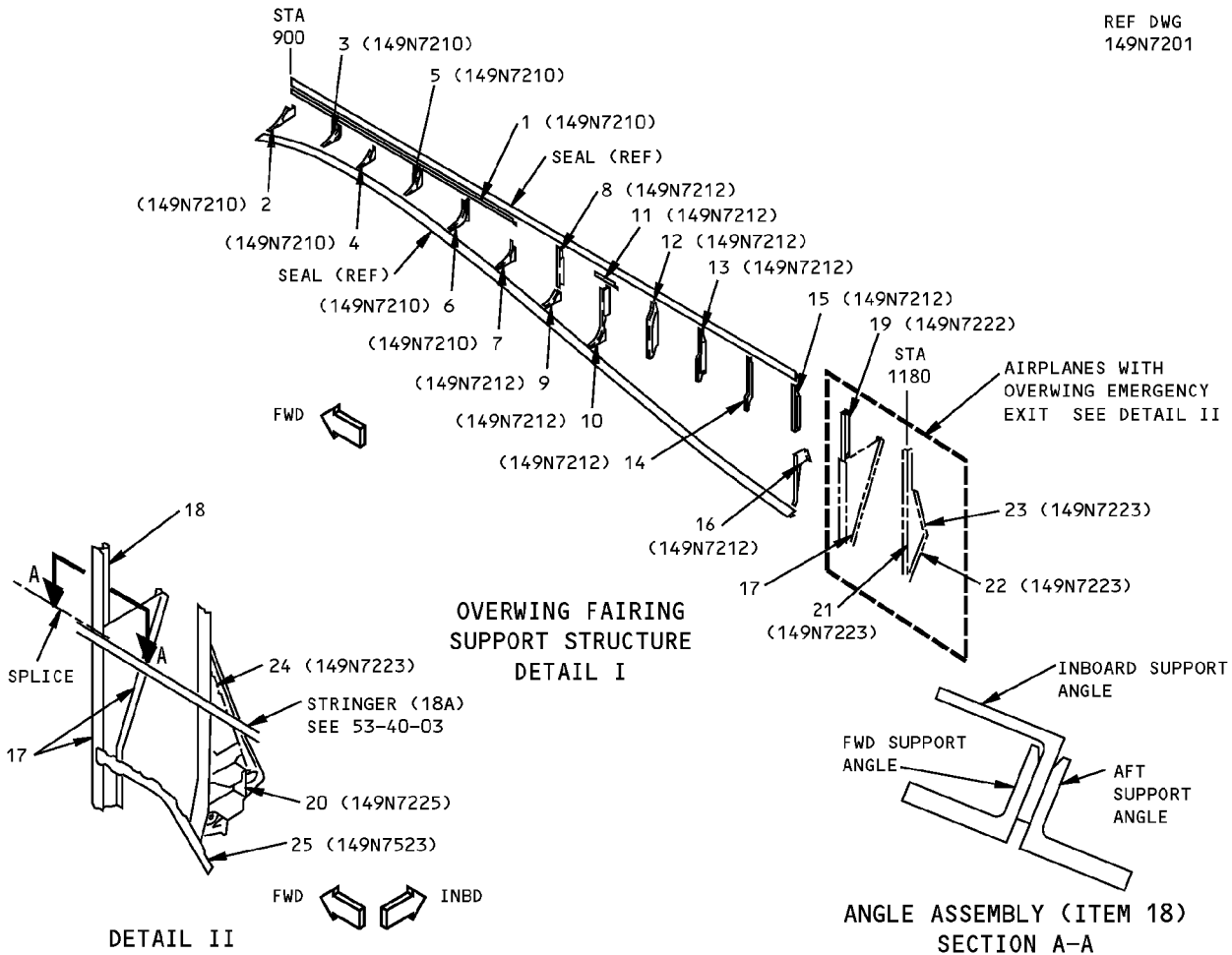
NOTES

- A** FOR CUM LINE NUMBERS:
1 THRU 520
- B** FOR AIRPLANES NOT LISTED IN **A** .

Section 44 Fairing Structure Identification
Figure 1 (Sheet 1 of 7)

**757-200
STRUCTURAL REPAIR MANUAL**

REF DWG
149N7201



ITEM	DESCRIPTION	GAGE	MATERIAL	EFFECTIVITY
1	ZEE	0.080	CLAD 7075-T6	
2	SUPPORT ASSY SUPPORT ANGLE		BAC1505-100695 7075-T73511 AND10134-1403 7075-T3	
3	SUPPORT ASSY SUPPORT ANGLE		BAC1505-100667 7075-T73511 AND10134-1406 7075-T73	
4	SUPPORT ASSY SUPPORT ANGLE	0.080	BAC1505-100667 7075-T73511 CLAD 7075-T6	
5	SUPPORT ASSY SUPPORT ANGLE	0.080	AND10136-2407 7075-T73511 CLAD 7075-T6	
6	SUPPORT ASSY SUPPORT ANGLE	0.063	AND10136-2404 7075-T73511 CLAD 7075-T6	

LIST OF MATERIALS FOR DETAILS I AND II

**Section 44 Fairing Structure Identification
Figure 1 (Sheet 2 of 7)**

IDENTIFICATION 1
Page 2
Jan 20/2005

53-40-71

D634N201



**757-200
STRUCTURAL REPAIR MANUAL**

ITEM	DESCRIPTION	GAGE	MATERIAL	EFFECTIVITY
7	SUPPORT ASSY SUPPORT ANGLE	0.080	BAC1505-100674 7075-T73511 CLAD 7075-T6	
8	SUPPORT ASSY SUPPORT ANGLE	0.080	BAC1505-100403 7075-T6511 CLAD 7075-T6	
9	SUPPORT ASSY SUPPORT ANGLE	0.080	BAC1505-100628 7075-T73511 CLAD 7075-T6	
10	SUPPORT ASSY SUPPORT SUPPORT ANGLE	0.080	BAC1505-100674 7075-T73511 BAC1503-13107 7075-T6511 CLAD 7075-T6	
11	SUPPORT ANGLE	0.090	CLAD 7075-T6	
12	SUPPORT ASSY SUPPORT ANGLE		BAC1505-101100 7075-T6511 BAC1505-100403 7075-T73	
13	SUPPORT ASSY SUPPORT ANGLE	0.071	BAC1505-100674 7075-T73511 CLAD 7075-T6	
14	SUPPORT ASSY SUPPORT ANGLE		BAC1505-100351 7075-T73511 BAC1505-100403 7075-T73	
15	SUPPORT ASSY SUPPORT ANGLE		BAC1505-100351 7075-T73511 BAC1505-100403 7075-T73511	
16	SUPPORT	0.125	CLAD 7075-T6	
17	FRAME ASSY OUTER CHORD INNER CHORD WEB	0.050	BAC1505-100403 7075-T73 BAC1505-100403 7075-T73 CLAD 7075-T6	
18	ANGLE ASSY FWD ANGLE AFT ANGLE INBD ANGLE		BAC1503-100631 7075-T6511 OR BAC1503-100631 7075-T73511 BAC1503-100631 7075-T6511 OR BAC1503-100631 7075-T73511 AND10133-1403 7075-T73511	
19	SUPPORT ANGLE		AND10133-1403 7075-T73511	
20	ACTUATOR ATTACH FITTING		7075-T73 FORGING OR FORGED BLOCK	
21	FRAME ASSY OUTER CHORD WEB	0.040	BAC1505-100886 7075-T73 CLAD 7075-T6	
22	SUPPORT ANGLE		AND10133-2401 7075-T73	
23	STIFFENER	0.090	CLAD 7075-T6	
24	FRAME ASSY OUTER CHORD INNER CHORD WEB	0.050	AND10136-2403 7075-T6511 AND10133-1402 7075-T6511 CLAD 7075-T6	
25	CHORD		BAC1505-100886 7075-T6	

LIST OF MATERIALS FOR DETAILS I AND II (CONT)

**Section 44 Fairing Structure Identification
Figure 1 (Sheet 3 of 7)**

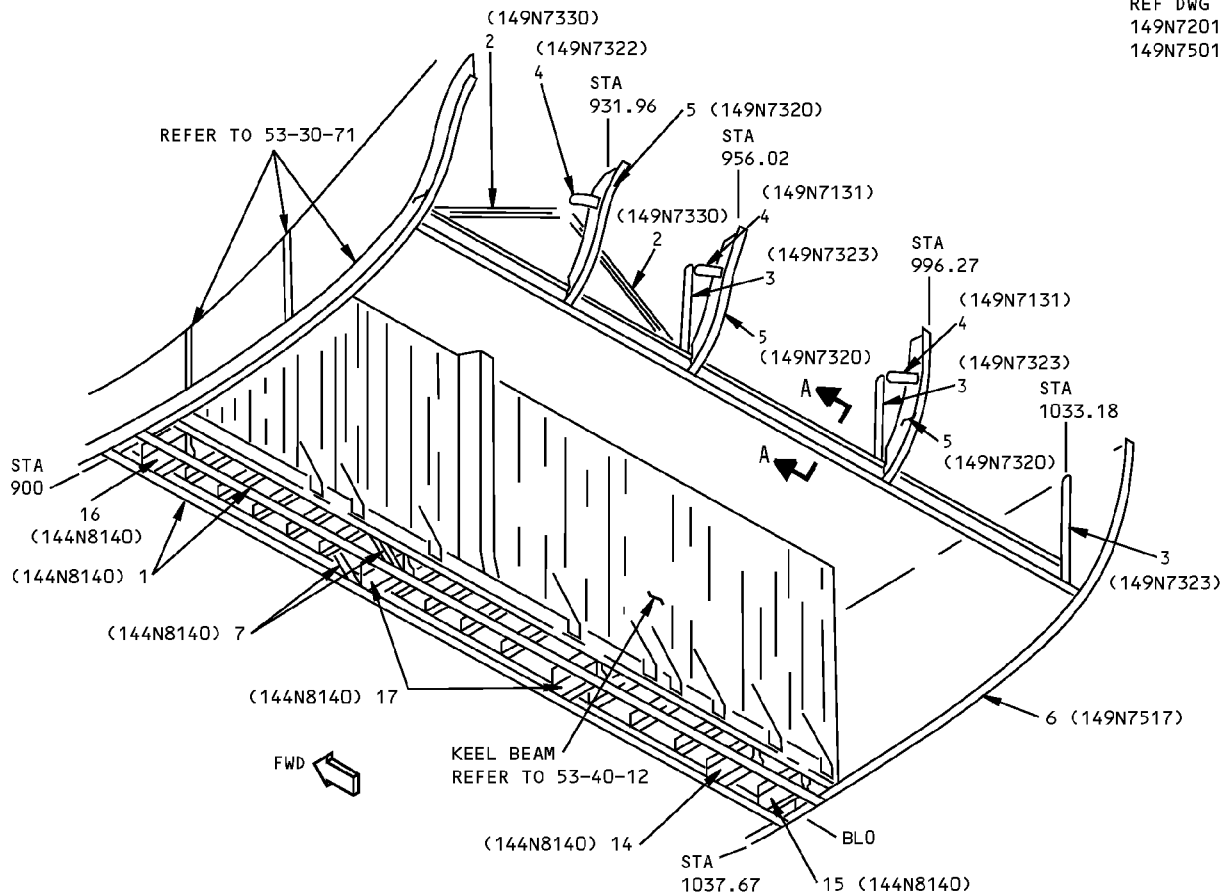
IDENTIFICATION 1
Page 3
Jan 20/2005

53-40-71

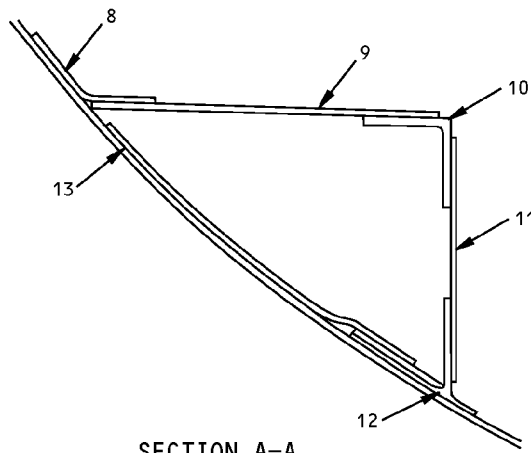
D634N201

757-200
STRUCTURAL REPAIR MANUAL

REF DWG
149N7201
149N7501



UNDERWING FAIRING SUPPORT STRUCTURE
DETAIL III



Section 44 Fairing Structure Identification
Figure 1 (Sheet 4 of 7)



IDENTIFICATION 1
Page 4
Jan 20/2005

53-40-71

D634N201



**757-200
STRUCTURAL REPAIR MANUAL**

ITEM	DESCRIPTION	GAGE	MATERIAL	EFFECTIVITY
1	BEAM		BAC1505-100049 7075-T73	
2	TRUSS		BAC1505-100541 7075-T73511	
3	TUBE	1.00	2024-T42	
4	LINK	0.80	2024-T351	
5	FRAME	0.063	CLAD 7075-T6	
6	CHORD		BAC1505-101100 7075-T73	
7	ANGLE		AND10133-2401 7075-T73	
8	ANGLE	0.05	CLAD 7075-T6	
9	INTERCOSTAL	0.05	CLAD 7075-T6	
10	ANGLE		BAC1514-13 7075-T73	
11	WEB	0.063	CLAD 7075-T6	
12	TEE		BAC1505-100915 7075-T73	
13	INTERCOSTAL	0.063	CLAD 7075-T6	
14	SUPPORT UPPER WEB TEE LOWER WEB	0.04 0.063	7075-T6 BAC1505-100647 7075-T73 7075-T73	
15	SUPPORT WEB FORGING TEE	0.063	7075-T73 7075-T73 BAC1505-100393 7075-T73	
16	SUPPORT WEB CHANNEL TEE	0.063 0.063	7075-T73 7075-T73 BAC1505-101014 7075-T73511	
17	SUPPORT WEB FITTING TEE	0.04	7075-T73 BAC1505-100667 7075-T73511 BAC1505-100393 7075-T73	

LIST OF MATERIALS FOR DETAIL III

**Section 44 Fairing Structure Identification
Figure 1 (Sheet 5 of 7)**

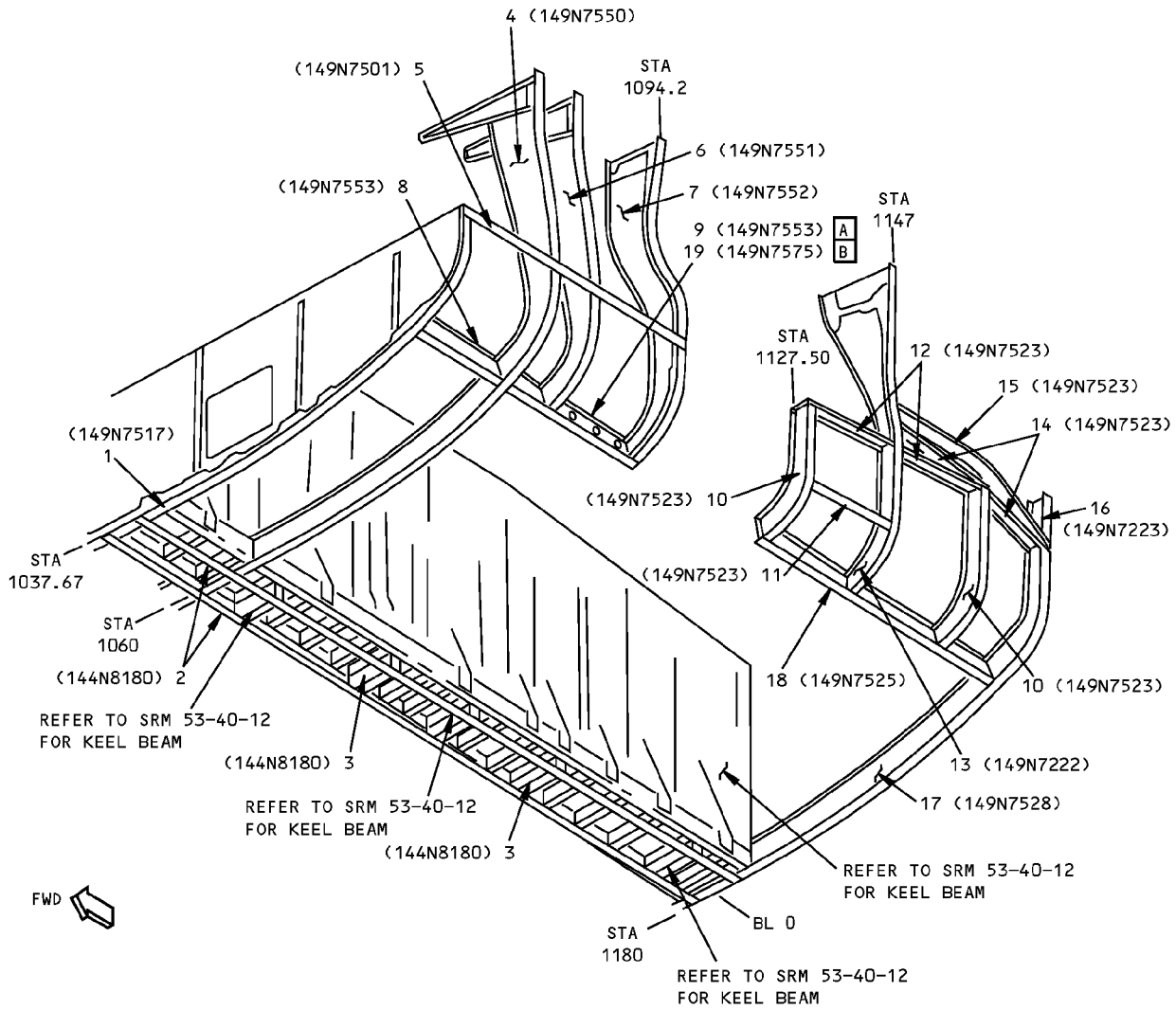
D634N201

53-40-71

IDENTIFICATION 1
Page 5
Jan 20/2005

**757-200
STRUCTURAL REPAIR MANUAL**

REFERENCE DRAWING
149N7201
149N7501



**UNDERWING FAIRING SUPPORT STRUCTURE
DETAIL IV**

LIST OF
MATL

**Section 44 Fairing Structure Identification
Figure 1 (Sheet 6 of 7)**

IDENTIFICATION 1
Page 6
Jan 20/2005

53-40-71

D634N201



**757-200
STRUCTURAL REPAIR MANUAL**

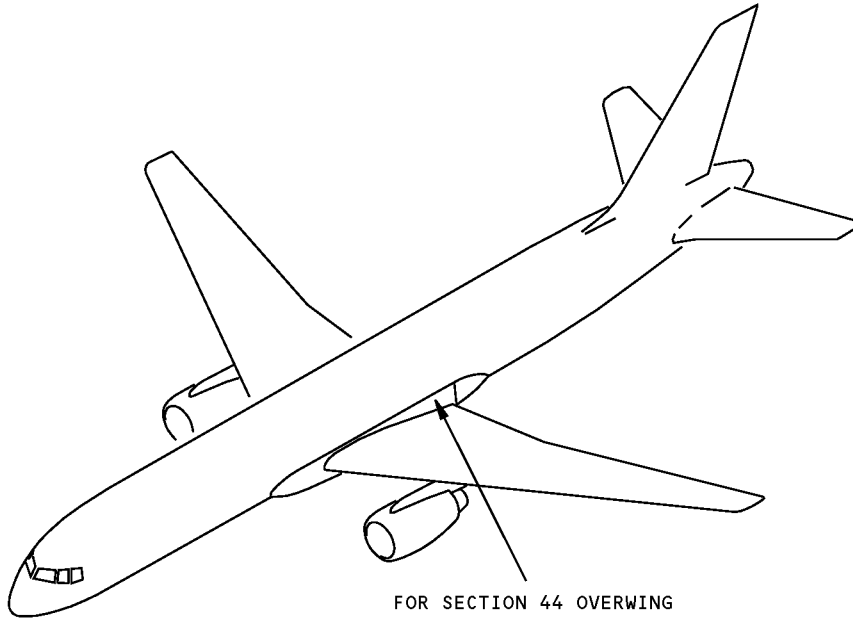
ITEM	DESCRIPTION	GAGE	MATERIAL	EFFECTIVITY
1	CHORD		BAC1505-101100 7075-T73	
2	BEAM		AND10136-3005 7075-T6511	
3	SUPPORT			
	WEB	0.063	CLAD 7075-T6	
	FITTING	0.063	CLAD 7075-T6	
	TEE		AND10133-1001 7075-T6511	
4	BEAM			
	WEB	0.063	CLAD 7075-T6	
	OUTER CHORD		BAC1505-100403 7075-T6	
	INNER CHORD	0.063	CLAD 7075-T6	
5	ANGLE	0.100	CLAD 7075-T6	
6	BEAM			
	WEB	0.063	7075-T6	
	OUTER CHORD		BAC1505-101099 7075-T6	
	INNER CHORD		AND10134-1205 7075-T6	
7	BEAM			
	CHANNEL	0.04	CLAD 2024-T42	
	WEB	0.036	CLAD 7075-T6	
	OUTER CHORD		BAC1505-100403 7075-T6	
	INNER CHORD		AND10136-2404 7075-T6	
8	BEAM			
	WEB	0.05	7075-T6	
	CHORD		BAC1505-100886 7075-T6	
9	CHANNEL	0.05	CLAD 7075-T6	A
10	BEAM			
	OUTER CHORD	0.063	CLAD 7075-T6	
	INNER CHORD	0.063	CLAD 7075-T6	
11	STIFFENER	0.05	CLAD 7075-T6	
12	BEAM			
	OUTER CHORD	0.063	CLAD 7075-T6	
	INNER CHORD	0.071	CLAD 7075-T6	
13	BEAM			
	WEB	0.05	CLAD 7075-T6	
	OUTER CHORD		BAC1505-100403 7075-T73	
	INNER CHORD		BAC1505-100403 7075-T73	
14	INTERCOSTAL	0.063	CLAD 7075-T6	
15	BEAM			
	INTERCOSTAL	0.063	CLAD 7075-T6	
	CHORD		BAC1505-100886 7075-T6	
16	BEAM			
	WEB	0.04	CLAD 7075-T6	
	CHORD		BAC1505-100203 7075-T6	
	ANGLE	0.09	CLAD 7075-T6	
17	BEAM			
	WEB	0.063	CLAD 7075-T6	
	CHORD		BAC1505-100403 7075-T6	
18	CHANNEL	0.071	CLAD 7075-T6	
19	CHANNEL	0.100	CLAD 7075-T6	B

LIST OF MATERIALS FOR DETAIL IV

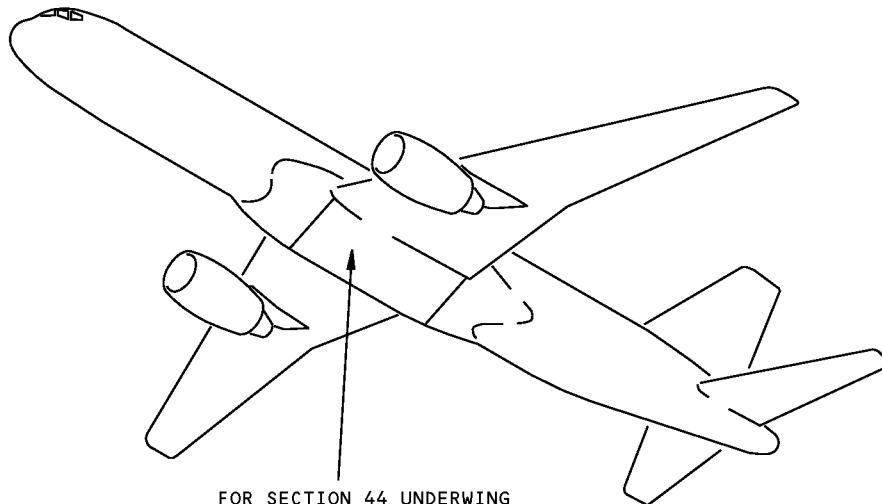
**Section 44 Fairing Structure Identification
Figure 1 (Sheet 7 of 7)**

757-200
STRUCTURAL REPAIR MANUAL

ALLOWABLE DAMAGE GENERAL - SECTION 44 - WING-TO-BODY FAIRING STRUCTURE



FOR SECTION 44 OVERWING
FAIRING STRUCTURE
ALLOWABLE DAMAGE SEE 53-00-71



FOR SECTION 44 UNDERWING
FAIRING STRUCTURE
ALLOWABLE DAMAGE SEE 53-00-71

Section 44 Wing-to-Body Fairing Structure Allowable Damage
Figure 101



757-200
STRUCTURAL REPAIR MANUAL

REPAIR GENERAL - SECTION 44 - WING-TO-BODY FAIRING STRUCTURE

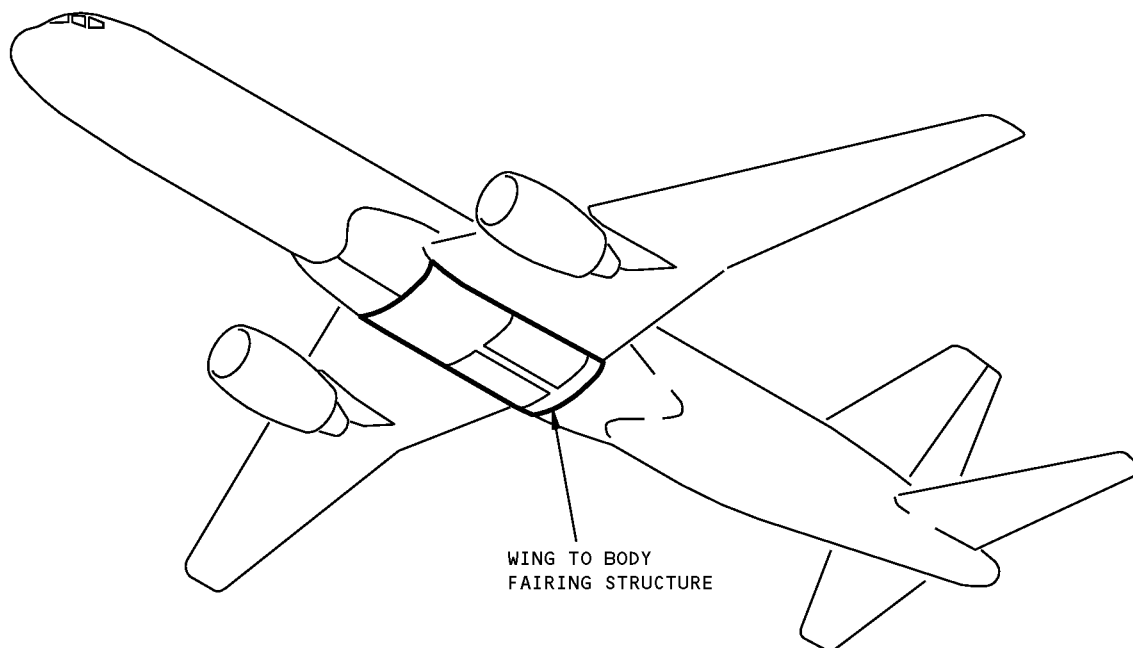
SERVICE BULLETIN REPAIRS

The following Service Bulletins contain repairs which are available for use where specific damage has been encountered. Usually, the Service Bulletin also covers preventive modification data which operators are encouraged to use to eliminate the need for repair.

DAMAGED AREA	CUM LINE NUMBER EFFECTIVITY	SB NUMBER
FUSELAGE - MAIN LANDING GEAR WHEEL WELL - CANTED BEAM CHANGE	1 THRU 521	757-53-0062

Section 44 Wing-to-Body Fairing Structure Repair
Figure 201 (Sheet 1 of 2)

757-200
STRUCTURAL REPAIR MANUAL



NOTES

- REFER TO SRM 51-70-11 FOR FORMED SECTION REPAIR
- REFER TO SRM 51-70-12 FOR EXTRUDED SECTION REPAIR
- REFER TO SRM 51-70-13 FOR WEB REPAIRS

Section 44 Wing-to-Body Fairing Structure Repair
Figure 201 (Sheet 2 of 2)

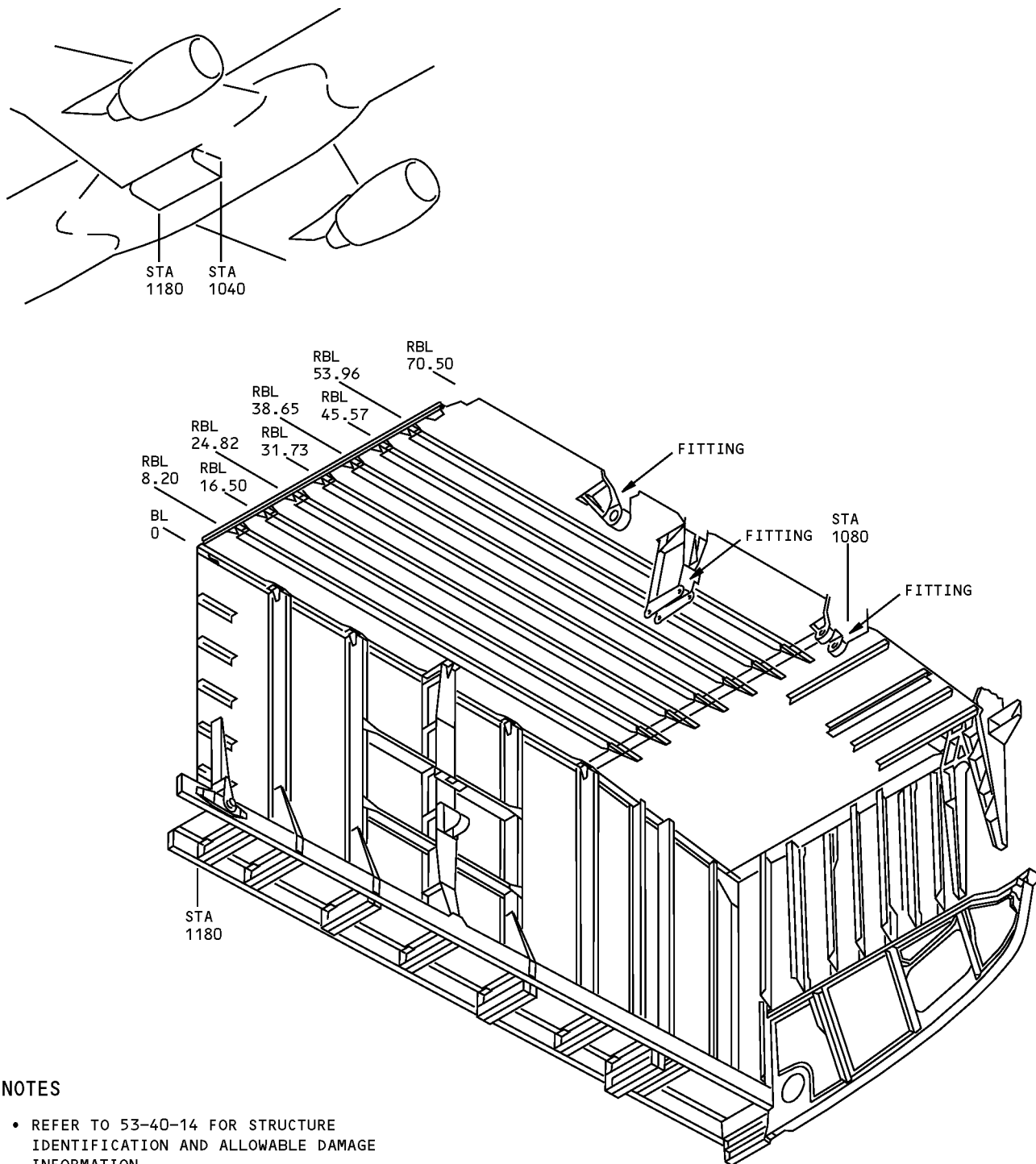
D634N201

53-40-71

REPAIR GENERAL
Page 202
Jan 20/2005

**757-200
STRUCTURAL REPAIR MANUAL**

REPAIR GENERAL - SECTION 44 - MAIN LANDING GEAR WHEEL WELL FITTINGS



NOTES

- REFER TO 53-40-14 FOR STRUCTURE IDENTIFICATION AND ALLOWABLE DAMAGE INFORMATION
- NO TYPICAL REPAIR TO FITTINGS APPLICABLE
SPECIFIC REPAIRS TO FITTINGS WILL BE PROVIDED BASED ON SERVICE EXPERIENCE

**Section 44 Main Landing Gear Wheel Well Fitting Repair
Figure 201**

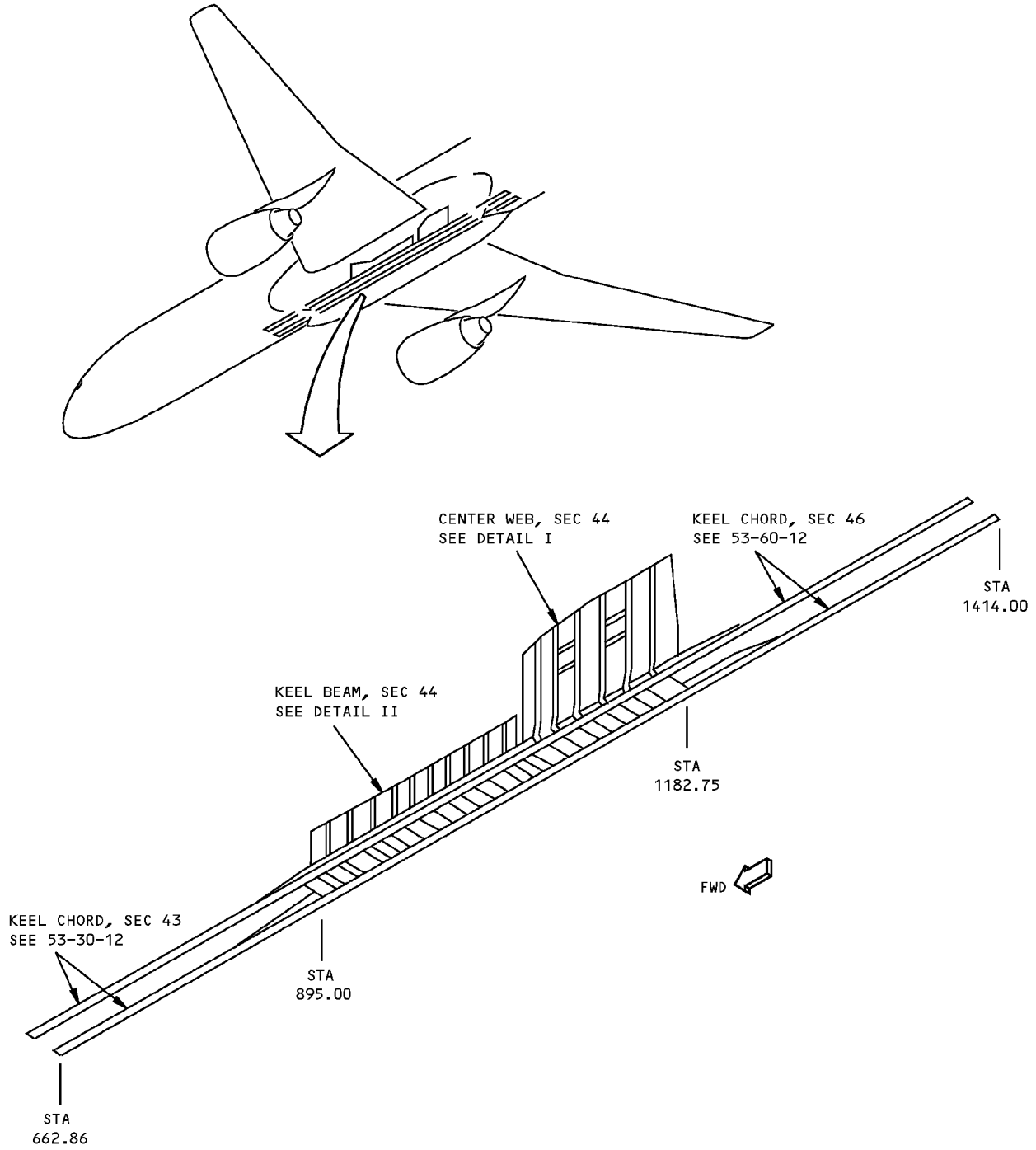
D634N201

53-40-90

REPAIR GENERAL
Page 201
Jan 20/2005

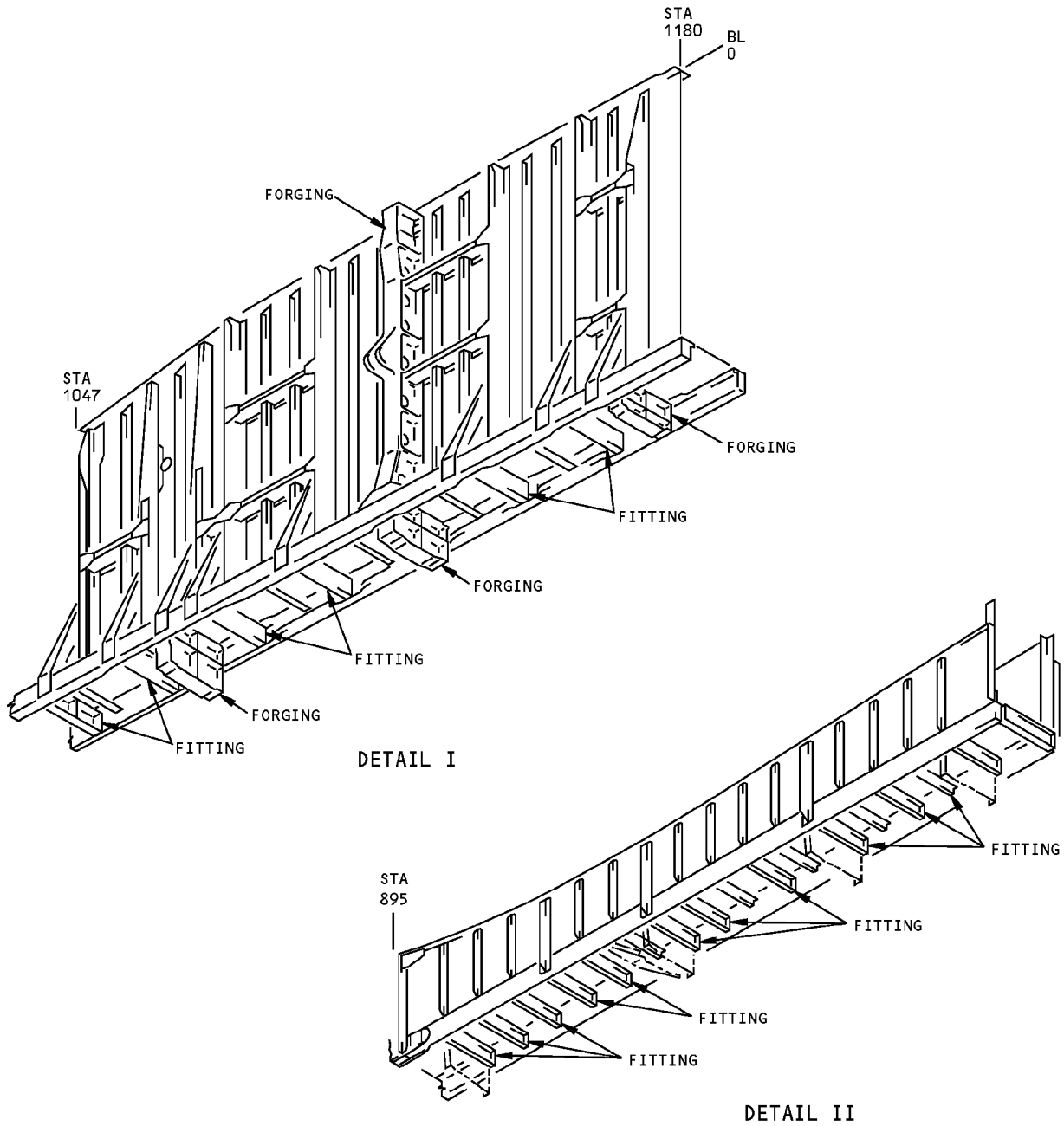
**757-200
STRUCTURAL REPAIR MANUAL**

REPAIR 1 - SECTION 44 - KEEL BEAM FITTINGS



**Section 44 Keel Beam Fitting Repair
Figure 201 (Sheet 1 of 2)**

**757-200
STRUCTURAL REPAIR MANUAL**



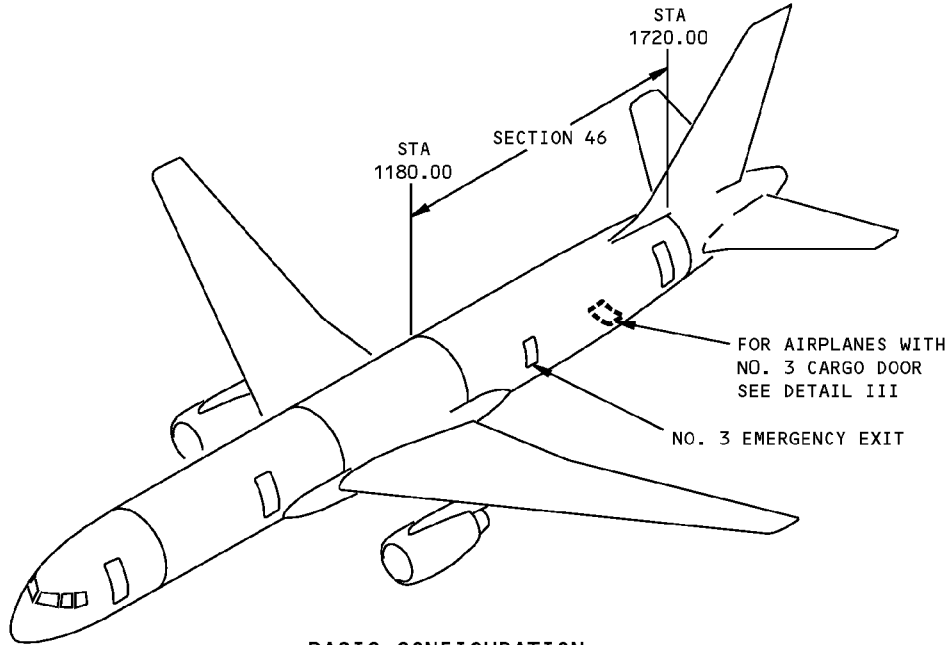
NOTES

- SEE 53-40-12 FOR STRUCTURE IDENTIFICATION AND ALLOWABLE DAMAGE INFORMATION
- NO TYPICAL REPAIR TO FITTINGS APPLICABLE. SPECIFIC REPAIRS TO FITTINGS WILL BE PROVIDED BASED ON SERVICE EXPERIENCE

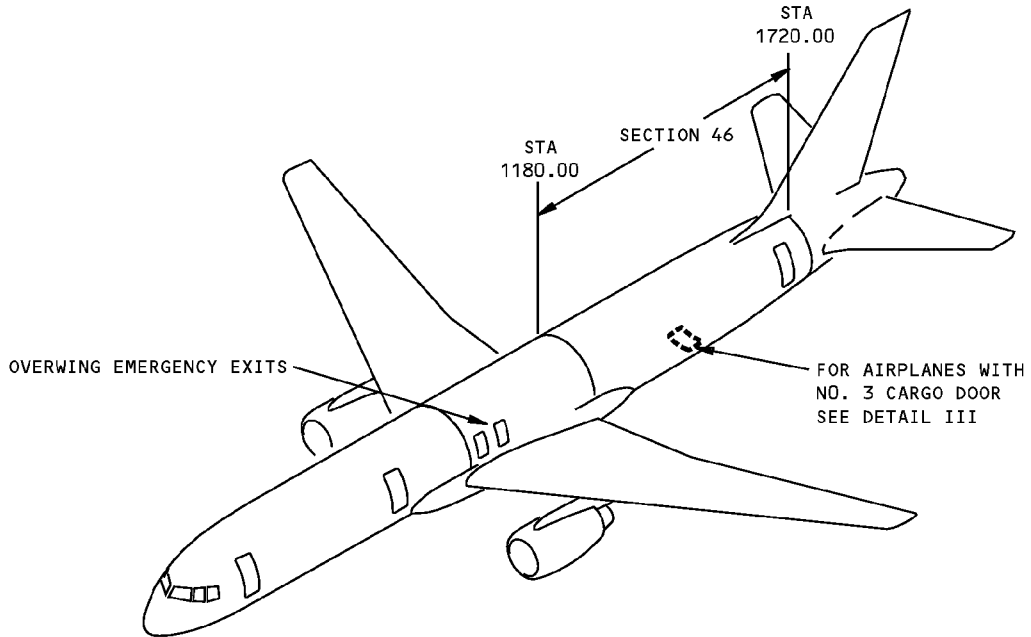
**Section 44 Keel Beam Fitting Repair
Figure 201 (Sheet 2 of 2)**

**757-200
STRUCTURAL REPAIR MANUAL**

IDENTIFICATION 1 - SECTION 46 - SKINS



**BASIC CONFIGURATION
AIRPLANES WITH NO. 3 EMERGENCY EXIT
SEE DETAILS I AND II**



**BASIC CONFIGURATION
AIRPLANES WITH OVERWING EMERGENCY EXITS
SEE DETAILS IV AND V**

**Section 46 Skin Identification
Figure 1 (Sheet 1 of 7)**



757-200
STRUCTURAL REPAIR MANUAL

NOTES

- | | |
|--|---|
| <p>A CONFIGURATIONS THAT HAVE THESE WINDOWS ARE AN OPERATOR OPTION</p> | <p>F FOR CUM LINE NUMBERS:
5 AND ON</p> |
| <p>B FOR CUM LINE NUMBERS:
14 THRU 18</p> | <p>G FOR CUM LINE NUMBERS:
61 AND ON</p> |
| <p>C FOR ALL AIRPLANEES WITH NO. 3 EMERGENCY EXIT AND NOT IN B</p> | <p>H FOR CUM LINE NUMBERS:
37,39,41,43 THRU 49</p> |
| <p>D CONFIGURATIONS THAT HAVE THIS WINDOW ARE AN OPERATOR OPTION</p> | |
| <p>E FOR CUM LINE NUMBERS:
1 THRU 14</p> | |

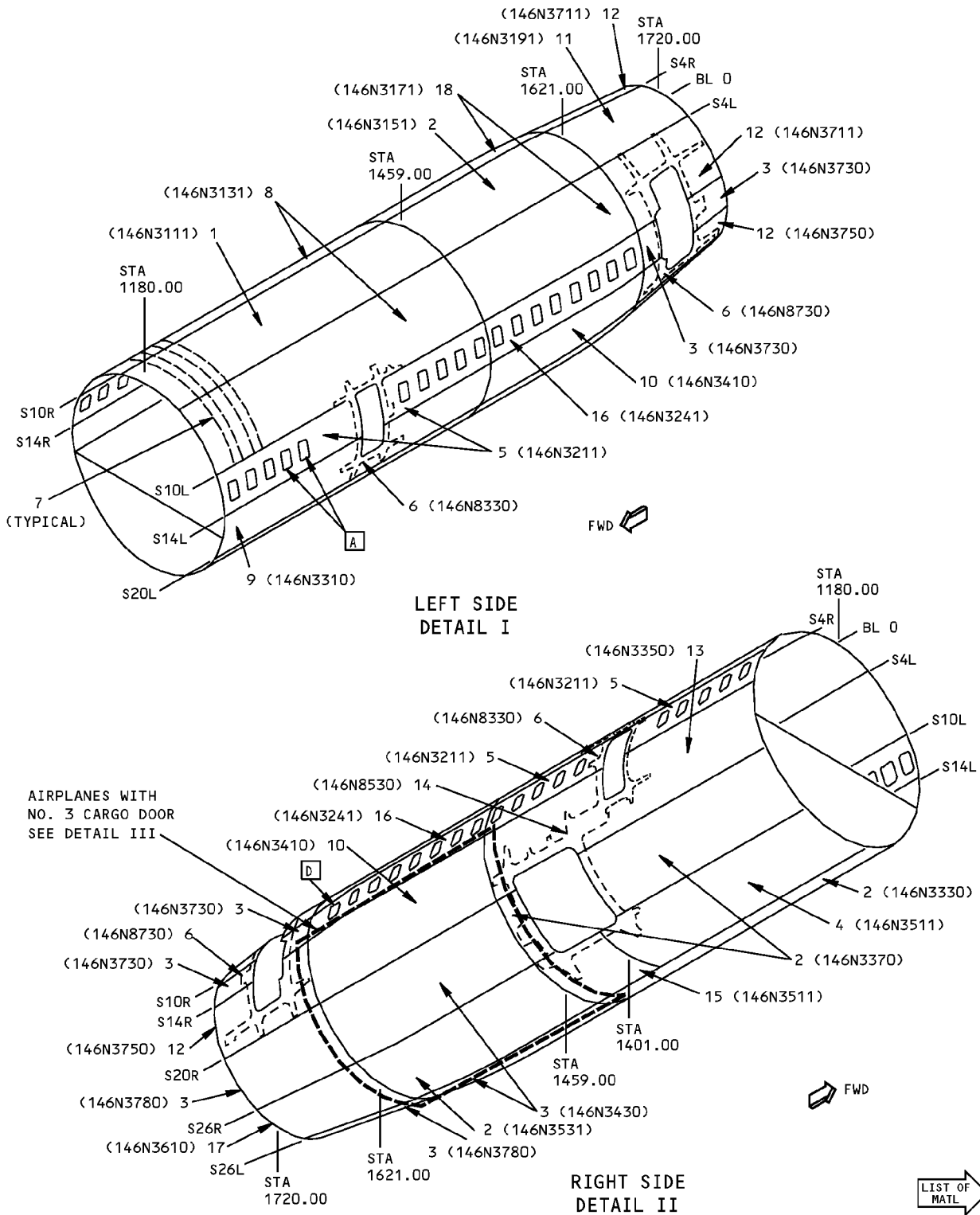
Section 46 Skin Identification
Figure 1 (Sheet 2 of 7)

D634N201

53-60-01

IDENTIFICATION 1
Page 2
Jan 20/2005

**757-200
STRUCTURAL REPAIR MANUAL**



**Section 46 Skin Identification
Figure 1 (Sheet 3 of 7)**



**757-200
STRUCTURAL REPAIR MANUAL**

ITEM	DESCRIPTION	GAGE	MATERIAL	EFFECTIVITY
1	SKIN MACHINED	0.125	2024-T3 CLAD (MACHINED TO 0.050 MIN)	
2	SKIN	0.090	2024-T3 CLAD (CHEM-MILLED TO 0.040MIN)	
3	SKIN	0.080	2024-T3 CLAD (CHEM-MILLED TO 0.040 MIN)	
4	SKIN MACHINED	0.200	2024-T3 CLAD (CHEM-MILLED TO 0.070 MIN)	
5	SKIN	0.160 0.155	CLAD 2024-T3 (CHEM-MILLED TO 0.080 MIN) CLAD 2024-T3 (CHEM-MILLED TO 0.080 MIN)	
6	DOUBLER	0.125	2024-T3	
7	TEARSTRAP	0.063	2024-T3	
8	SKIN	0.140	CLAD 2024-T3 (MACHINED TO 0.045 MIN)	
9	SKIN	0.140 0.125	CLAD 2024-T3 (CHEM-MILLED TO 0.040 MIN) CLAD 2024-T3 (CHEM-MILLED TO 0.040 MIN)	B C
10	SKIN	0.100	CLAD 2024-T3 (CHEM-MILLED TO 0.040 MIN)	
11	SKIN	0.100	CLAD 2024-T3 (CHEM-MILLED TO 0.040 MIN)	
12	SKIN	0.125	CLAD 2024-T3 (CHEM-MILLED TO 0.040 MIN)	
13	SKIN	0.120	CLAD 2024-T3 (CHEM-MILLED TO 0.050 MIN)	
14	DOUBLER	0.140	2024-T3	
15	SKIN	0.110 0.100	CLAD 2024-T3 (CHEM-MILLED TO 0.060 MIN) CLAD 2024-T3 (CHEM-MILLED TO 0.060 MIN)	
16	SKIN	0.090	CLAD 2024-T3 (CHEM-MILLED TO 0.060 MIN)	
17	SKIN	0.072 0.080	CLAD 2024-T3 (CHEM-MILLED TO 0.040 MIN) CLAD 2024-T3 (CHEM-MILLED TO 0.040 MIN)	E F
18	SKIN	0.090	CLAD 2024-T3 (CHEM-MILLED TO 0.040 MIN)	

LIST OF MATERIALS FOR DETAILS I AND II

**Section 46 Skin Identification
Figure 1 (Sheet 4 of 7)**

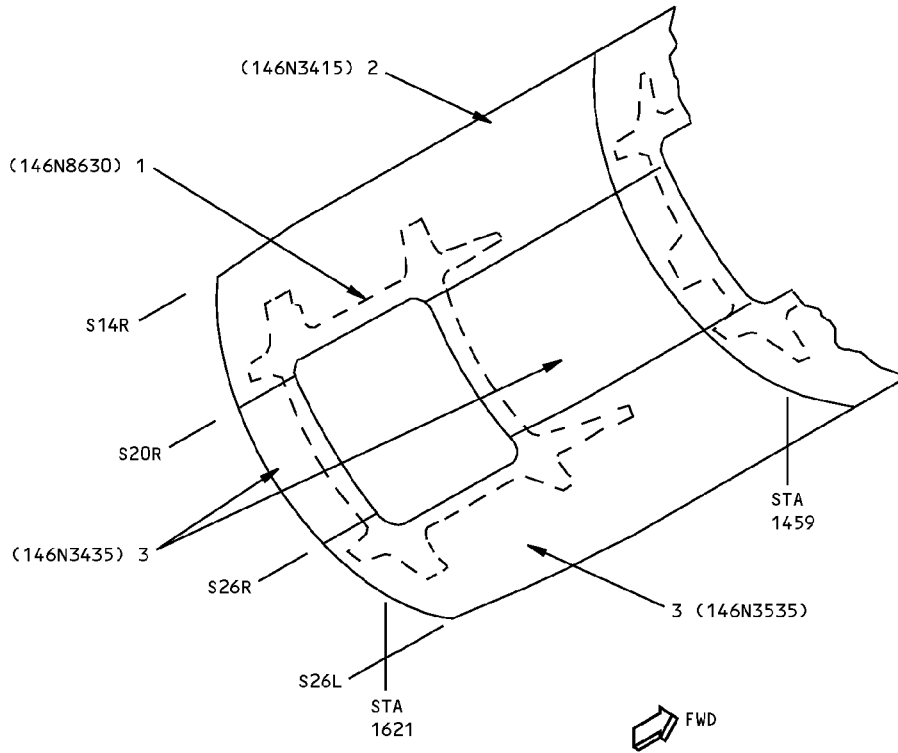
IDENTIFICATION 1
Page 4
Jan 20/2005

53-60-01

D634N201

**757-200
STRUCTURAL REPAIR MANUAL**

REF DWG
146N3400



**AIRPLANES WITH NO. 3 CARGO DOOR
DETAIL III**

ITEM	DESCRIPTION	GAGE	MATERIAL	EFFECTIVITY
1	DOUBLER	0.125	2024-T3	
2	SKIN	0.125	CLAD 2024-T3 CHEM MILLED	
3	SKIN	0.100	CLAD 2024-T3 CHEM MILLED	

LIST OF MATERIALS FOR DETAIL III

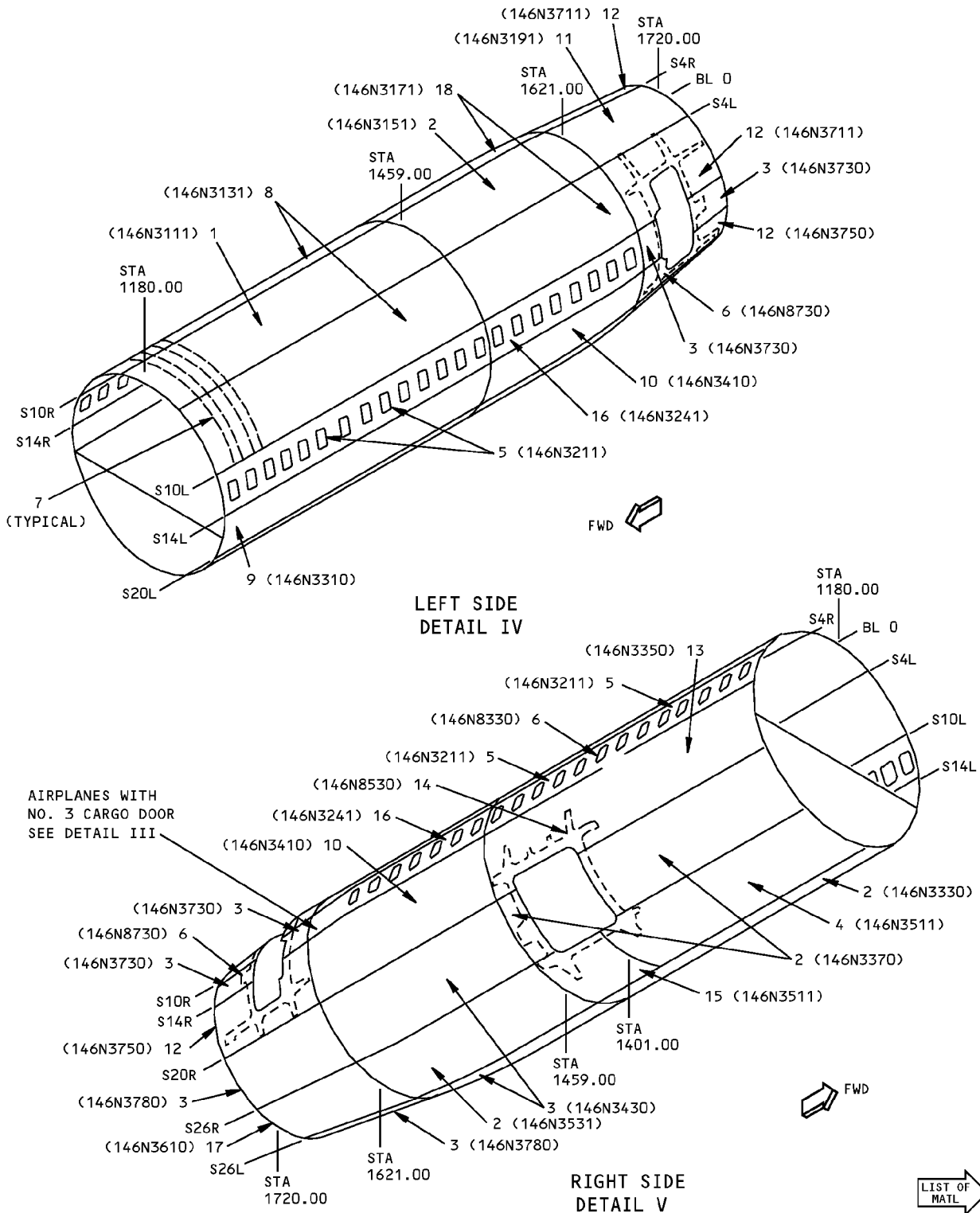
**Section 46 Skin Identification
Figure 1 (Sheet 5 of 7)**

D634N201

53-60-01

IDENTIFICATION 1
Page 5
Jan 20/2005

**757-200
STRUCTURAL REPAIR MANUAL**



**Section 46 Skin Identification
Figure 1 (Sheet 6 of 7)**



**757-200
STRUCTURAL REPAIR MANUAL**

ITEM	DESCRIPTION	GAGE	MATERIAL	EFFECTIVITY		
1	SKIN MACHINED	0.125	2024-T3 CLAD (MACHINED TO 0.050 MIN)	<table border="1"> <tr><td>G</td></tr> <tr><td>H</td></tr> </table>	G	H
G						
H						
2	SKIN	0.090	2024-T3 CLAD (CHEM-MILLED TO 0.040 MIN)			
3	SKIN	0.080	2024-T3 CLAD (CHEM-MILLED TO 0.040 MIN)			
4	SKIN MACHINED	0.200 0.210	2024-T3 CLAD (CHEM-MILLED TO 0.070 MIN) 2024-T3 CLAD (CHEM-MILLED TO 0.070 MIN)			
5	SKIN OPTIONAL	0.160 0.155	CLAD 2024-T3 (CHEM-MILLED TO 0.080 MIN) CLAD 2024-T3 (CHEM-MILLED TO 0.080 MIN)			
6	DOUBLER	0.125	2024-T3			
7	TEARSTRAP	0.063	2024-T3			
8	SKIN	0.112	CLAD 2024-T3 (MACHINED TO 0.045 MIN)			
9	SKIN	0.120	CLAD 2024-T3 (CHEM-MILLED TO 0.040 MIN)			
10	SKIN	0.063	CLAD 2024-T3 (CHEM-MILLED TO 0.040 MIN)			
11	SKIN	0.100	CLAD 2024-T3 (CHEM-MILLED TO 0.040 MIN)			
12	SKIN	0.125	CLAD 2024-T3 (CHEM-MILLED TO 0.040 MIN)			
13	SKIN	0.120	CLAD 2024-T3 (CHEM-MILLED TO 0.050 MIN)			
14	DOUBLER	0.140	2024-T3			
15	SKIN	0.110	CLAD 2024-T3 (CHEM-MILLED TO 0.060 MIN)			
16	SKIN	0.090	CLAD 2024-T3 (CHEM-MILLED TO 0.060 MIN)			
17	SKIN	0.072	CLAD 2024-T3 (CHEM-MILLED TO 0.040 MIN)			
18	SKIN	0.090	CLAD 2024-T3 (CHEM-MILLED TO 0.040 MIN)			

LIST OF MATERIALS FOR DETAILS IV AND V

**Section 46 Skin Identification
Figure 1 (Sheet 7 of 7)**

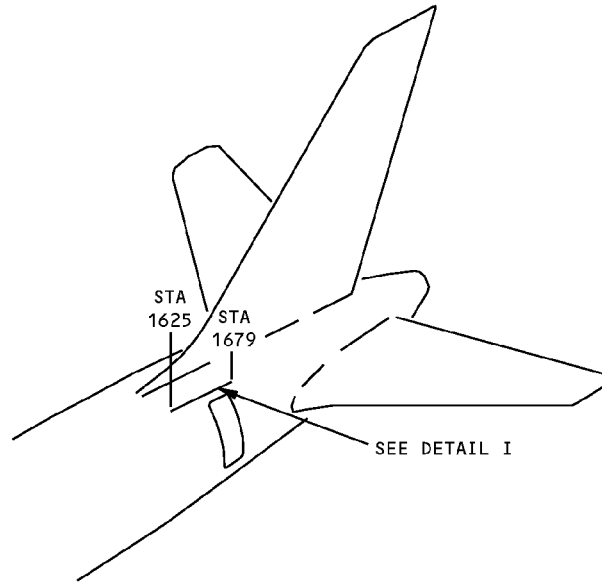
D634N201

53-60-01

IDENTIFICATION 1
Page 7
Jan 20/2005

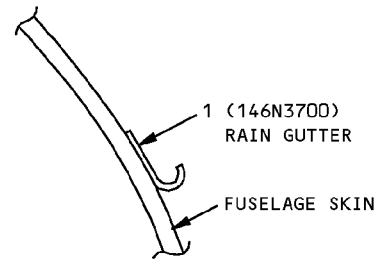
**757-200
STRUCTURAL REPAIR MANUAL**

IDENTIFICATION 2 - SECTION 46 - RAIN GUTTER



NOTES

- A** FOR CUM LINE NUMBERS: 1 THRU 23,
GUTTER IS BETWEEN STA 1640 AND STA 1679
- FOR CUM LINE NUMBERS: 24 AND ON,
GUTTER IS BETWEEN STA 1625 AND STA 1679



**SECTION THRU RAIN GUTTER
DETAIL I**

ITEM	DESCRIPTION	GAGE	MATERIAL	EFFECTIVITY
1	GUTTER		BAC1496-356 CLAD 2024-T3	A

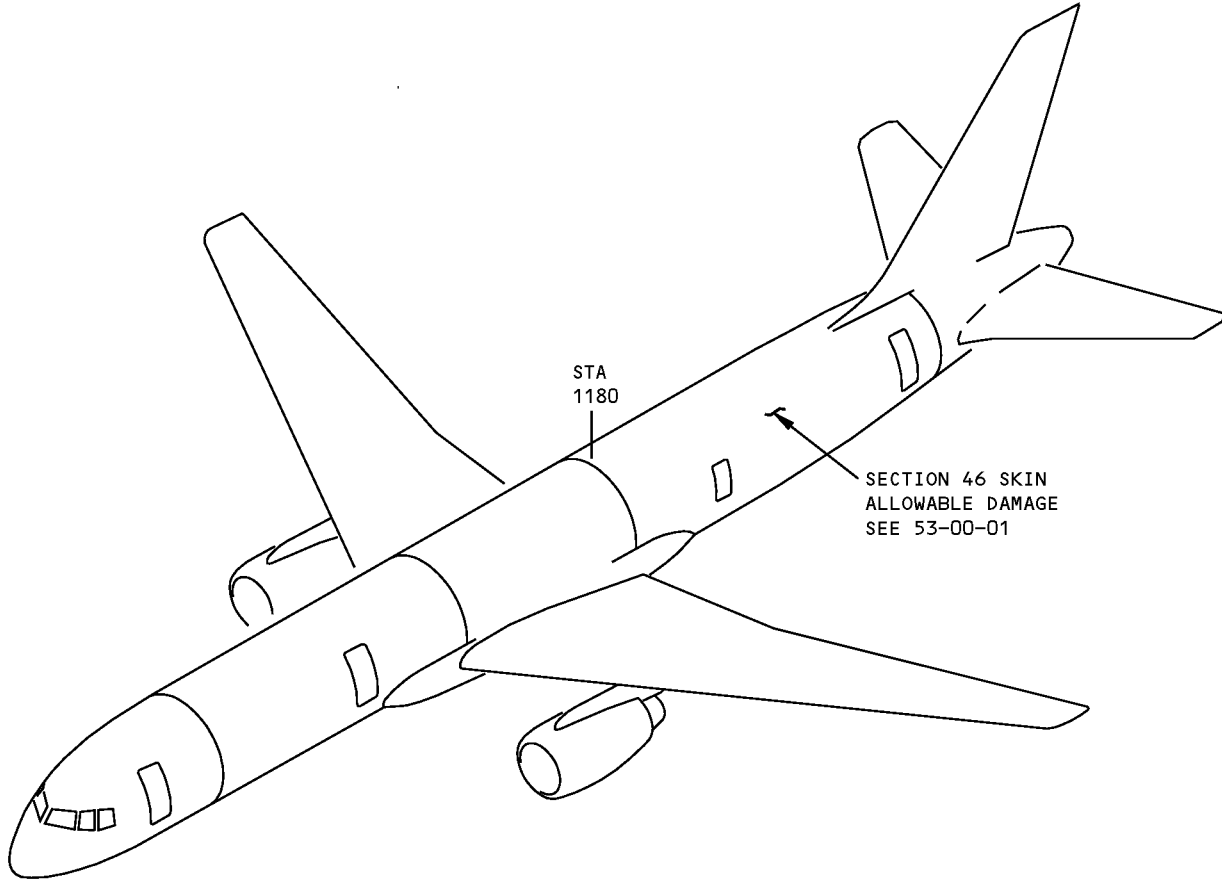
LIST OF MATERIALS FOR DETAIL I

**Section 46 Rain Gutter Identification
Figure 1**



757-200
STRUCTURAL REPAIR MANUAL

ALLOWABLE DAMAGE GENERAL - SECTION 46 - SKINS



Section 46 Skin Allowable Damage
Figure 101

D634N201

ALLOWABLE DAMAGE GENERAL
Page 101
53-60-01
Jan 20/2005



757-200
STRUCTURAL REPAIR MANUAL

REPAIR GENERAL - SECTION 46 - SKINS

SERVICE BULLETIN REPAIRS

The following service bulletins contain Section 46 skin repairs which are available for use where specific damage has been encountered. Usually, the service bulletin also covers preventive modification data which operators are encouraged to use to eliminate the need for repair.

DAMAGED AREA	CUM LINE NUMBER EFFECTIVITY <input type="checkbox"/>	SB NUMBER
FUSELAGE-SKIN, LOWER AFT VHF ANTENNA MOUNT, BS 1473 AND UPPER VHF ANTENNA MOUNT, BS 753	ALL 757 AIRPLANES	757-53A0053

FOR AIRPLANES ON WHICH PREVENTIVE MODIFICATION HAS NOT BEEN ACCOMPLISHED

Section 46 Skin Repairs
Figure 201 (Sheet 1 of 2)

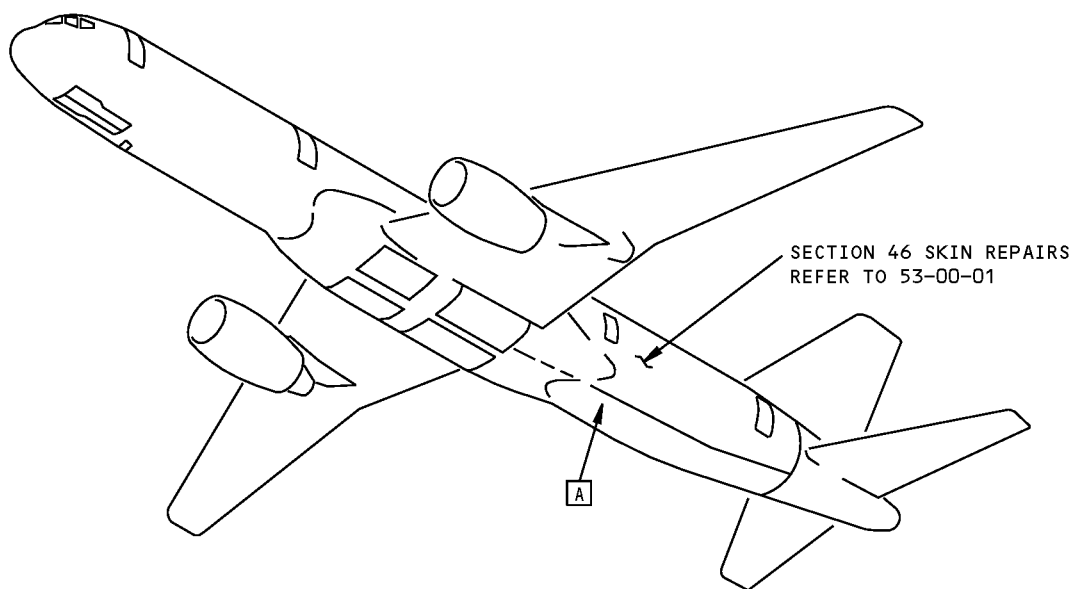
D634N201

53-60-01

REPAIR GENERAL
Page 201
Jan 20/2005



757-200
STRUCTURAL REPAIR MANUAL



NOTES

- A** FOR CUM LINE NUMBERS 257 THRU 280:
FOR REPAIRS INVOLVING SKIN REPLACEMENT
COMMON TO THE STRINGER 26L LAP SPLICE,
SEE REPAIR DRAWING 691N0015.

Section 46 Skin Repairs
Figure 201 (Sheet 2 of 2)

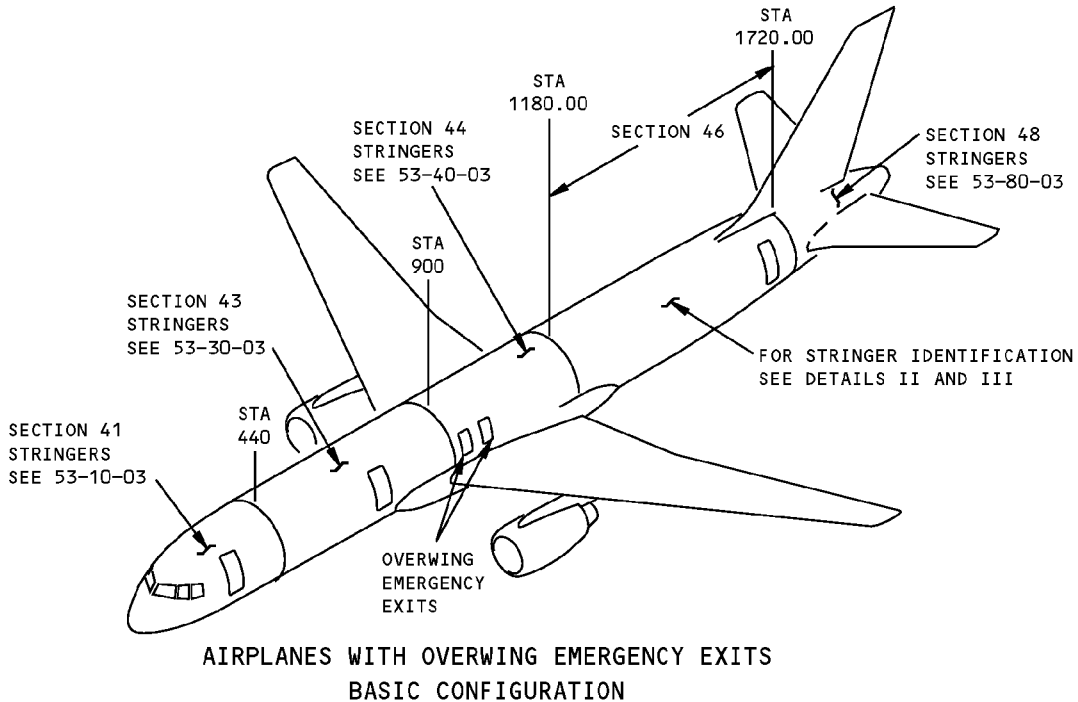
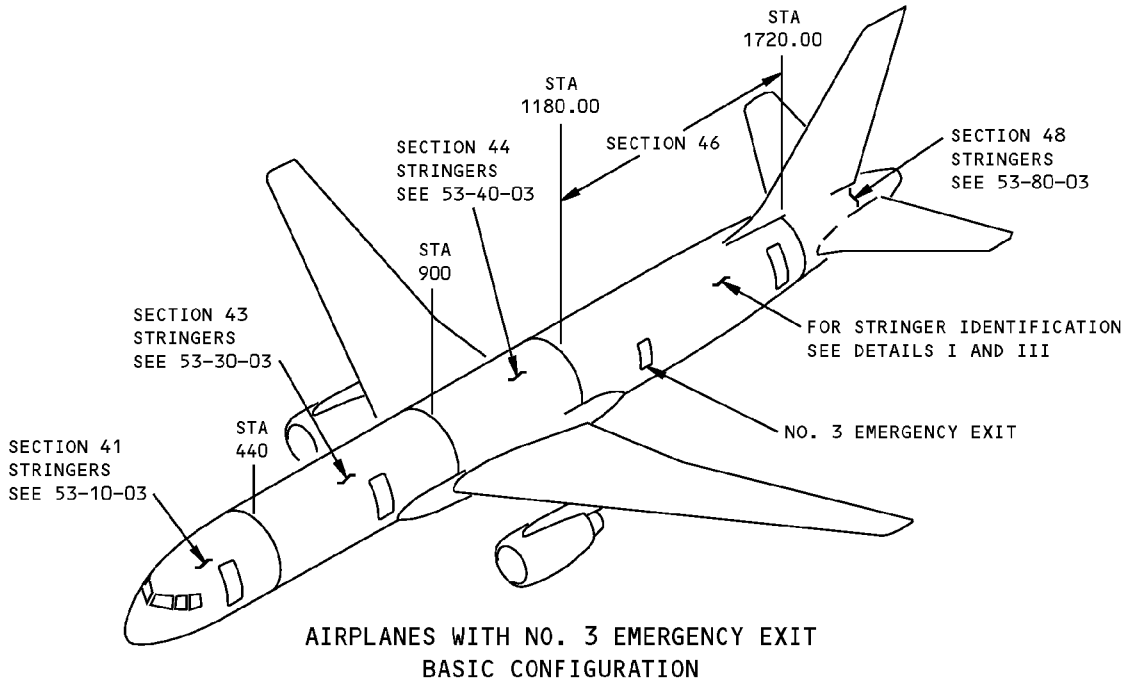
D634N201

53-60-01

REPAIR GENERAL
Page 202
Jan 20/2005

**757-200
STRUCTURAL REPAIR MANUAL**

IDENTIFICATION 1 - SECTION 46 - STRINGERS

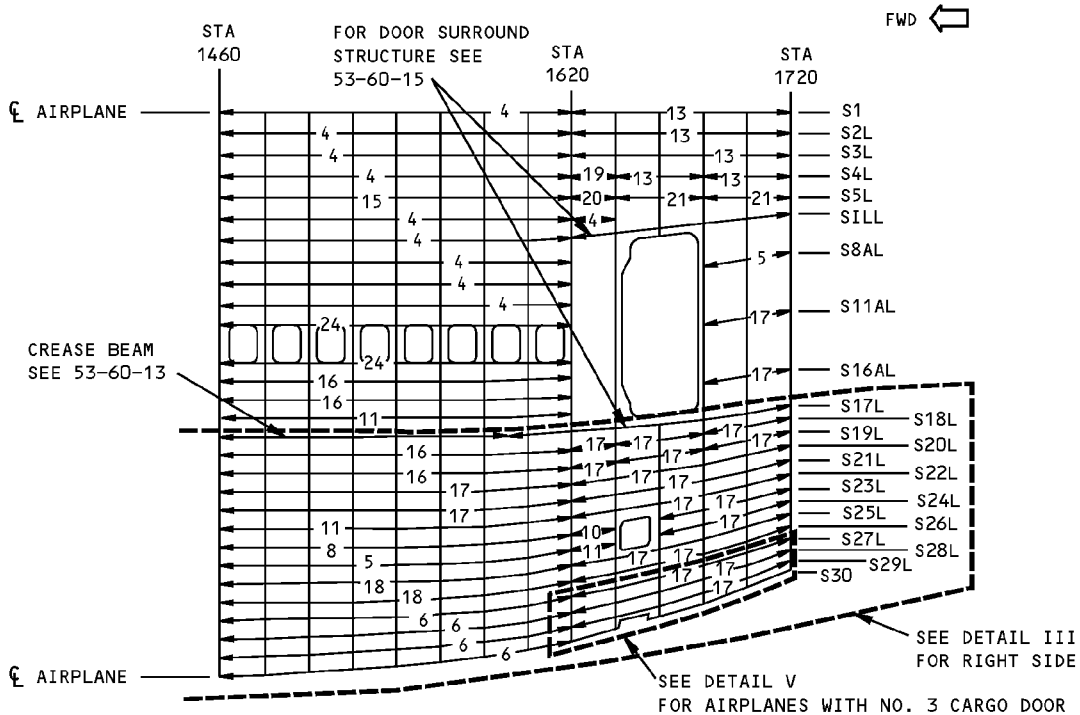
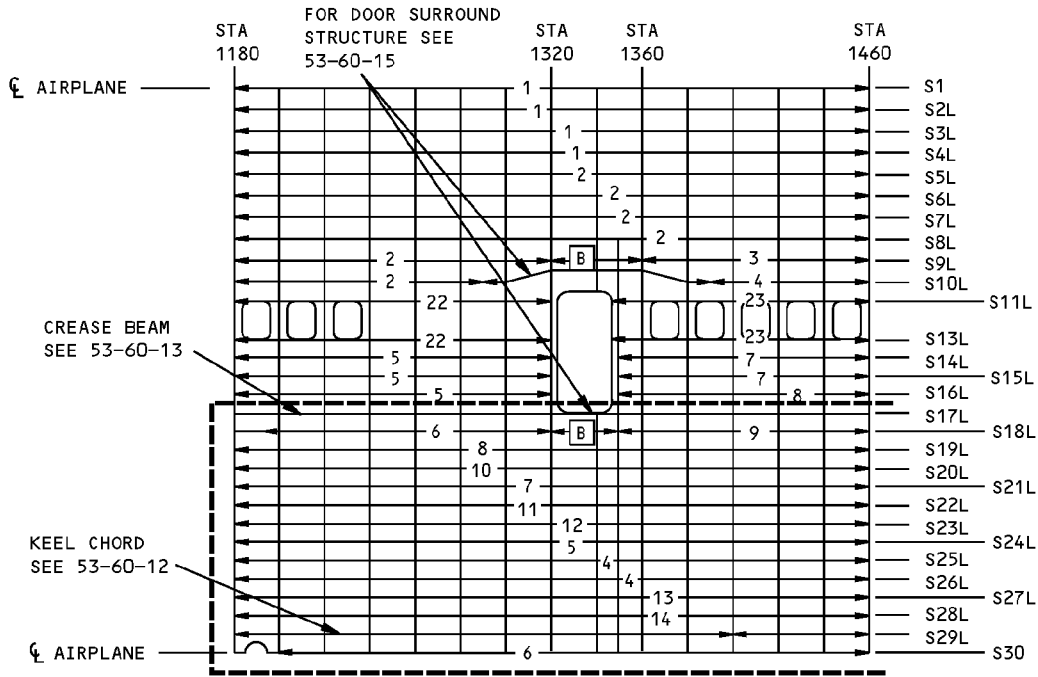


NOTES

- A** GAGES VARY THROUGHOUT LENGTH OF THE STRINGER; MAXIMUM GAGE GIVEN
- B** STRINGER SPLICE - REF DWG 146N3821

**Section 46 Stringer Identification
Figure 1 (Sheet 1 of 8)**

757-200 STRUCTURAL REPAIR MANUAL



FOR AIRPLANES WITH NO. 3 EMERGENCY EXIT
LEFT SIDE SHOWN, RIGHT SIDE OPPOSITE EXCEPT AS NOTED
DETAIL I

LIST OF
MATL →

**Section 46 Stringer Identification
Figure 1 (Sheet 2 of 8)**



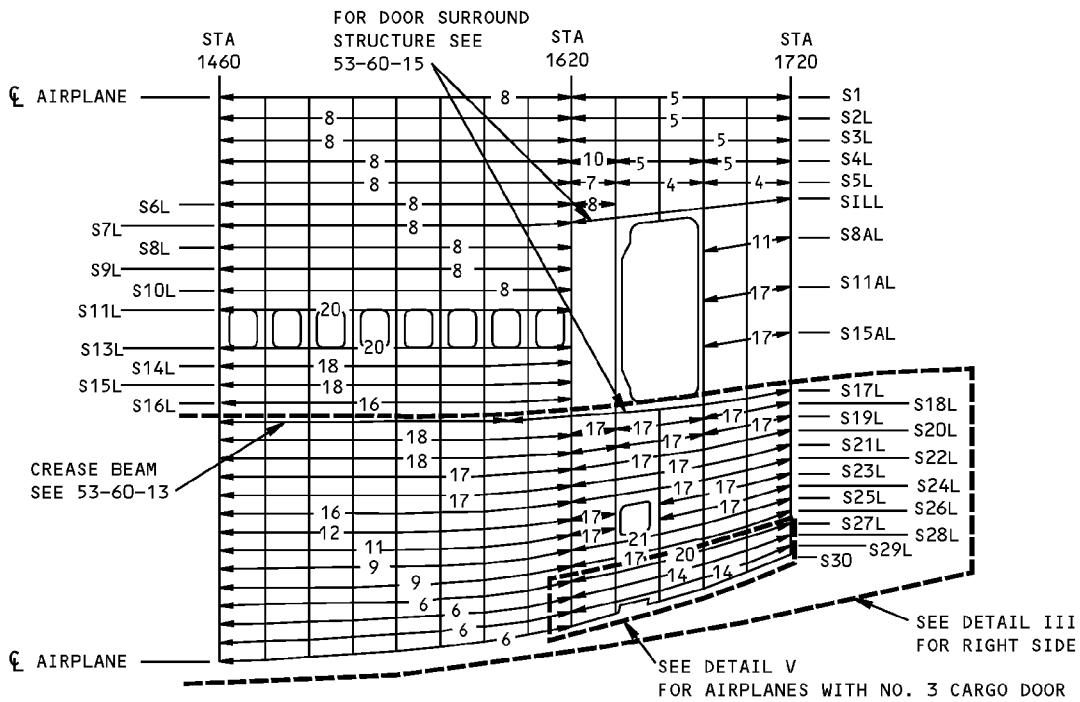
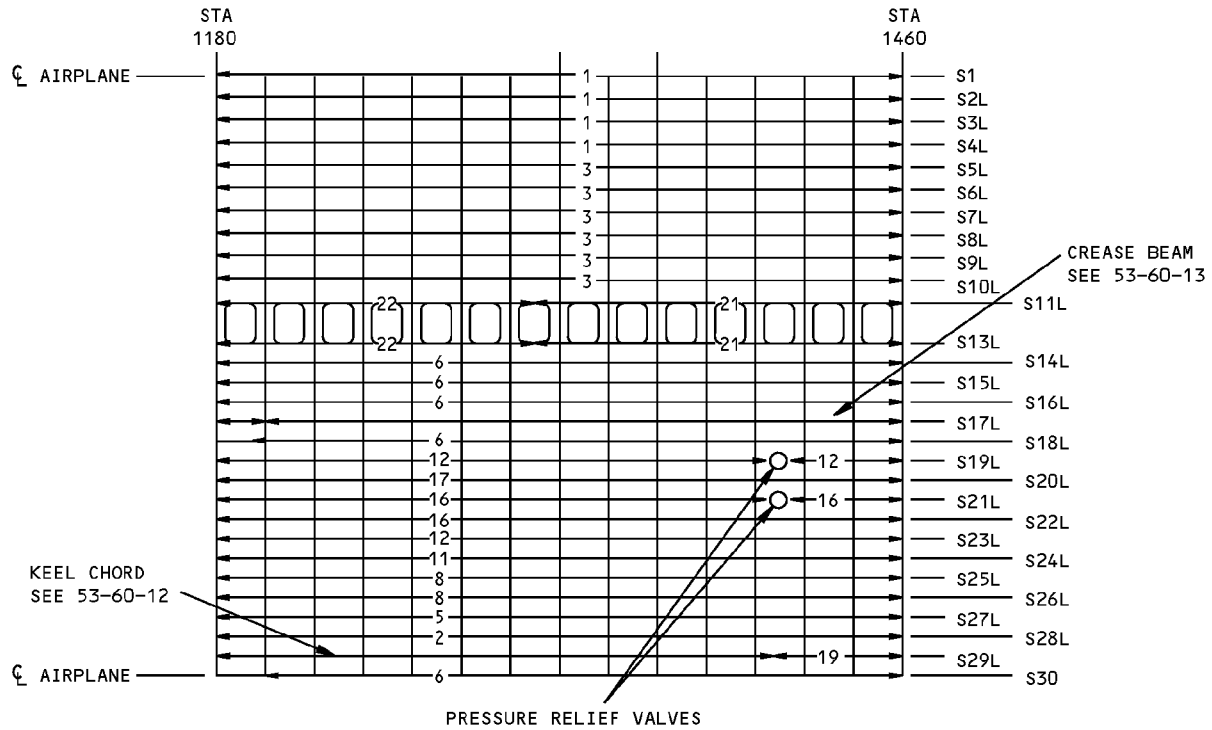
**757-200
STRUCTURAL REPAIR MANUAL**

ITEM	DESCRIPTION	GAGE	MATERIAL	STRINGER TYPE	REF DWG	EFFECTIVITY
1	STRINGER	0.136 [A]	7075-T6	U	140N1530	
2	STRINGER	0.112 [A]	7075-T6	U	140N1530	
3	STRINGER	0.104 [A]	7075-T6	U	140N1530	
4	STRINGER	0.080 [A]	7075-T6	U	140N1530	
5	STRINGER	0.063 [A]	7075-T6	U	140N1530	
6	STRINGER	0.090 [A]	7075-T6	U	140N1530	
7	STRINGER	0.053 [A]	7075-T6	U	140N1530	
8	STRINGER	0.056	7075-T6	U	140N1530	
9	STRINGER	0.071 [A]	7075-T6	U	140N1530	
10	STRINGER	0.047 [A]	7075-T6	U	140N1530	
11	STRINGER	0.050	7075-T6	U	140N1530	
12	STRINGER	0.059 [A]	7075-T6	U	140N1530	
13	STRINGER	0.100 [A]	7075-T6	U	140N1530	
14	STRINGER	0.125	7075-T6	U	140N1530	
15	STRINGER	0.084 [A]	7075-T6	U	140N1530	
16	STRINGER	0.040 [A]	7075-T6	U	140N1530	
17	STRINGER	0.045 [A]	7075-T6	U	140N1530	
18	STRINGER	0.078 [A]	7075-T6	U	140N1530	
19	STRINGER	0.072	7075-T6	U	140N1530	
20	STRINGER	0.084	7075-T6	U	140N1530	
21	STRINGER	0.102 [A]	7075-T6	U	140N1530	
22	STRINGER		BAC1517-1485 7075-T6511	I	146N3230	
23	STRINGER		BAC1517-1471 7075-T6511	I	146N3230	
24	STRINGER		BAC1517-1471 7075-T6	I	146N3230	

LIST OF MATERIALS FOR DETAIL I

**Section 46 Stringer Identification
Figure 1 (Sheet 3 of 8)**

757-200 STRUCTURAL REPAIR MANUAL



DETAIL II

**Section 46 Stringer Identification
Figure 1 (Sheet 4 of 8)**



**757-200
STRUCTURAL REPAIR MANUAL**

ITEM	DESCRIPTION	GAGE	MATERIAL	STRINGER TYPE	REF DWG	EFFECTIVITY
1	STRINGER	0.136 [A]	7075-T6	U	146N3110	
2	STRINGER	0.125 [A]	7075-T6	U	146N3110	
3	STRINGER	0.112 [A]	7075-T6	U	146N3110	
4	STRINGER	0.102 [A]	7075-T6	U	146N3110	
5	STRINGER	0.100 [A]	7075-T6	U	146N3110	
6	STRINGER	0.090 [A]	7075-T6	U	146N3110	
7	STRINGER	0.084 [A]	7075-T6	U	146N3110	
8	STRINGER	0.080 [A]	7075-T6	U	146N3110	
9	STRINGER	0.078 [A]	7075-T6	U	146N3110	
10	STRINGER	0.072 [A]	7075-T6	U	146N3110	
11	STRINGER	0.063 [A]	7075-T6	U	146N3110	
12	STRINGER	0.056 [A]	7075-T6	U	146N3110	
13	STRINGER	0.053 [A]	7075-T6	U	146N3110	
14	STRINGER	0.050 [A]	7075-T6	U	146N3110	
15	STRINGER	0.045 [A]	7075-T6	U	146N3110	
16	STRINGER	0.040 [A]	7075-T6	U	146N3110	
17	STRINGER	0.140 [A]	7075-T6	U	146N3110	
18	STRINGER	0.060 [A]	7075-T6	U	146N3110	
19	STRINGER	0.048 [A]	7075-T6	U	146N3110	
20	STRINGER		BAC 1517-1471 7075-T6	I	146N3230	
21	STRINGER		BAC 1517-1471 7075-T6511	I	146N3230	
22	STRINGER		BAC 1517-1485 7075-T6511	I	146N3230	

LIST OF MATERIALS FOR DETAIL II

**Section 46 Stringer Identification
Figure 1 (Sheet 5 of 8)**

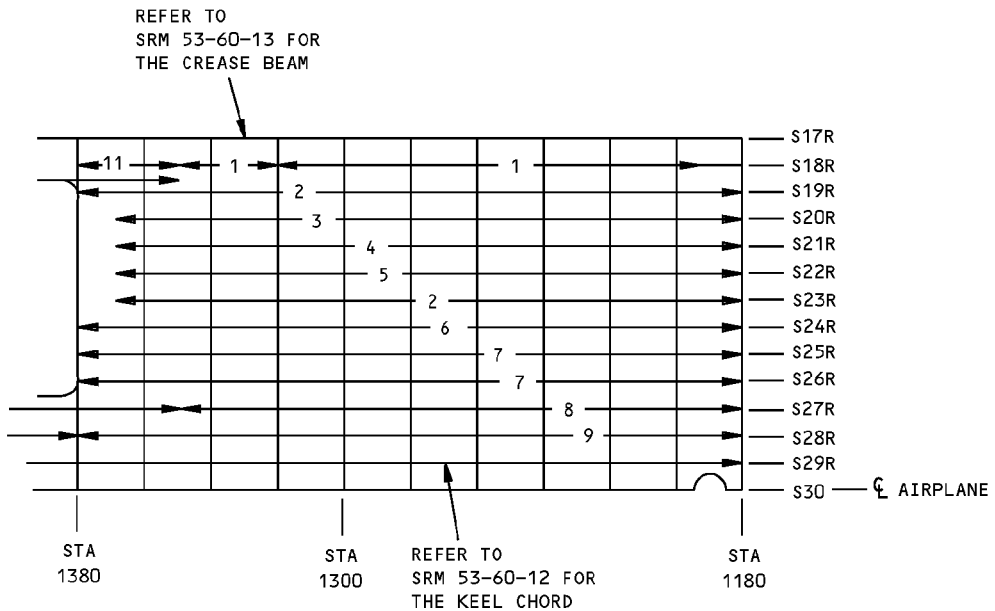
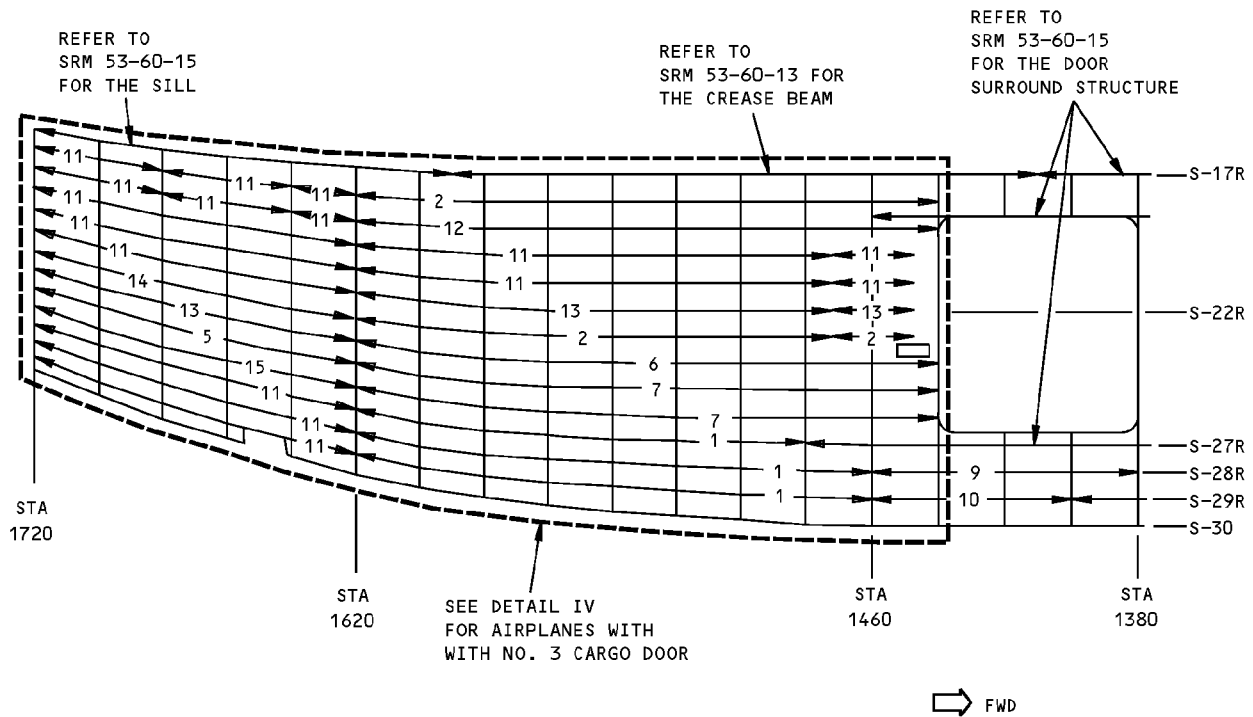
IDENTIFICATION 1

53-60-03

Page 5
Jan 20/2005

D634N201

**757-200
STRUCTURAL REPAIR MANUAL**



**RIGHT SIDE
DETAIL III**



**Section 46 Stringer Identification
Figure 1 (Sheet 6 of 8)**



757-200
STRUCTURAL REPAIR MANUAL

ITEM	DESCRIPTION	GAGE	MATERIAL	STRINGER TYPE	REF DWG	EFFECTIVITY
1	STRINGER	0.090 <input type="checkbox"/> A	7075-T6	U	140N1530	
2	STRINGER	0.056 <input type="checkbox"/> A	7075-T6	U	140N1530	
3	STRINGER	0.052 <input type="checkbox"/> A	7075-T6	U	140N1530	
4	STRINGER	0.054 <input type="checkbox"/> A	7075-T6	U	140N1530	
5	STRINGER	0.053 <input type="checkbox"/> A	7075-T6	U	140N1530	
6	STRINGER	0.063 <input type="checkbox"/> A	7075-T6	U	140N1530	
7	STRINGER	0.080 <input type="checkbox"/> A	7075-T6	U	140N1530	
8	STRINGER	0.100 <input type="checkbox"/> A	7075-T6	U	140N1530	
9	STRINGER	0.125 <input type="checkbox"/> A	7075-T6	U	140N1530	
10	STRINGER	0.140 <input type="checkbox"/> A	7075-T6	U	140N1530	
11	STRINGER	0.045 <input type="checkbox"/> A	7075-T6	U	140N1530	
12	STRINGER	0.040 <input type="checkbox"/> A	7075-T6	U	140N1530	
13	STRINGER	0.050 <input type="checkbox"/> A	7075-T6	U	140N1530	
14	STRINGER	0.047 <input type="checkbox"/> A	7075-T6	U	140N1530	
15	STRINGER	0.060 <input type="checkbox"/> A	7075-T6	U	140N1530	

LIST OF MATERIALS FOR DETAIL III

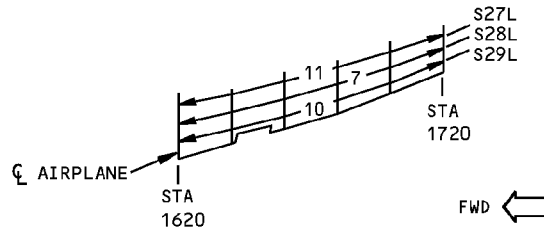
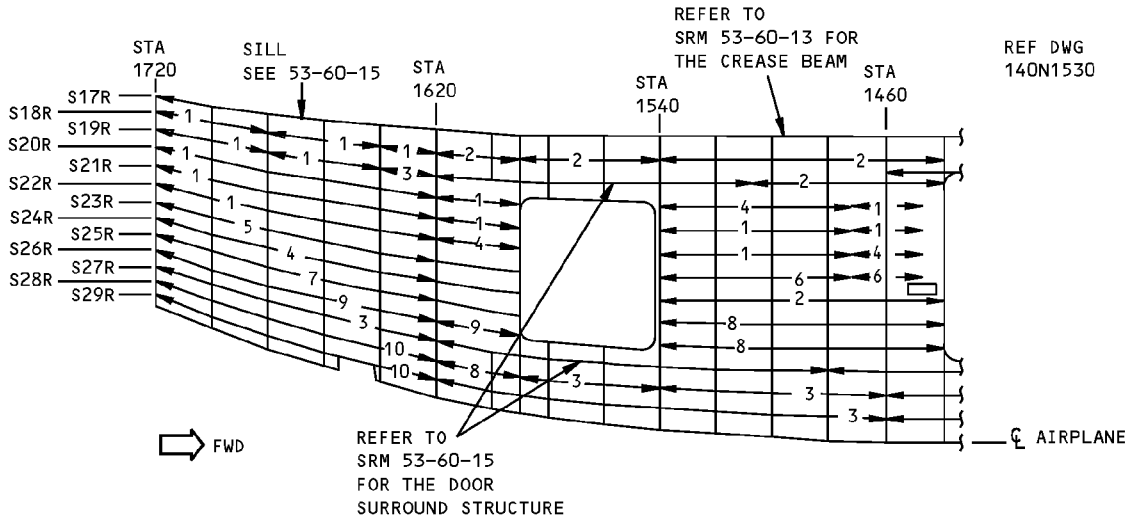
Section 46 Stringer Identification
Figure 1 (Sheet 7 of 8)

IDENTIFICATION 1
Page 7
Jan 20/2005

53-60-03

D634N201

757-200 STRUCTURAL REPAIR MANUAL



ITEM	DESCRIPTION	GAGE	MATERIAL	STRINGER TYPE	REF DWG	EFFECTIVITY
1	STRINGER	0.045 [A]	7075-T6		140N1530	
2	STRINGER	0.063 [A]	7075-T6		140N1530	
3	STRINGER	0.090 [A]	7075-T6		140N1530	
4	STRINGER	0.050 [A]	7075-T6		140N1530	
5	STRINGER	0.047 [A]	7075-T6		140N1530	
6	STRINGER	0.056 [A]	7075-T6		140N1530	
7	STRINGER	0.053 [A]	7075-T6		140N1530	
8	STRINGER	0.080 [A]	7075-T6		140N1530	
9	STRINGER	0.071 [A]	7075-T6		140N1530	
10	STRINGER	0.070 [A]	7075-T6		140N1530	
11	STRINGER	0.060 [A]	7075-T6		140N1530	

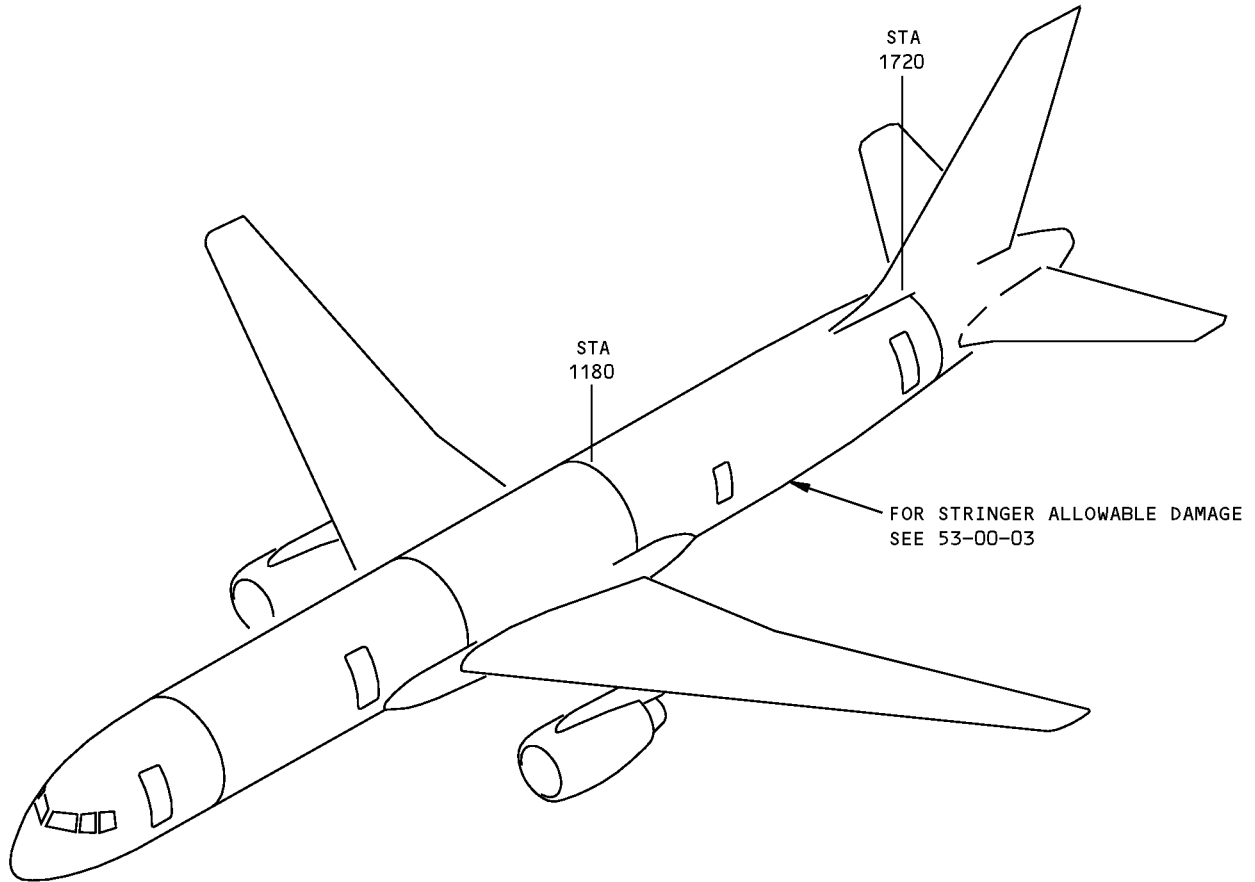
LIST OF MATERIALS FOR DETAILS IV AND V

**Section 46 Stringer Identification
Figure 1 (Sheet 8 of 8)**



757-200
STRUCTURAL REPAIR MANUAL

ALLOWABLE DAMAGE GENERAL - SECTION 46 - STRINGERS



Section 46 Stringer Allowable Damage
Figure 101

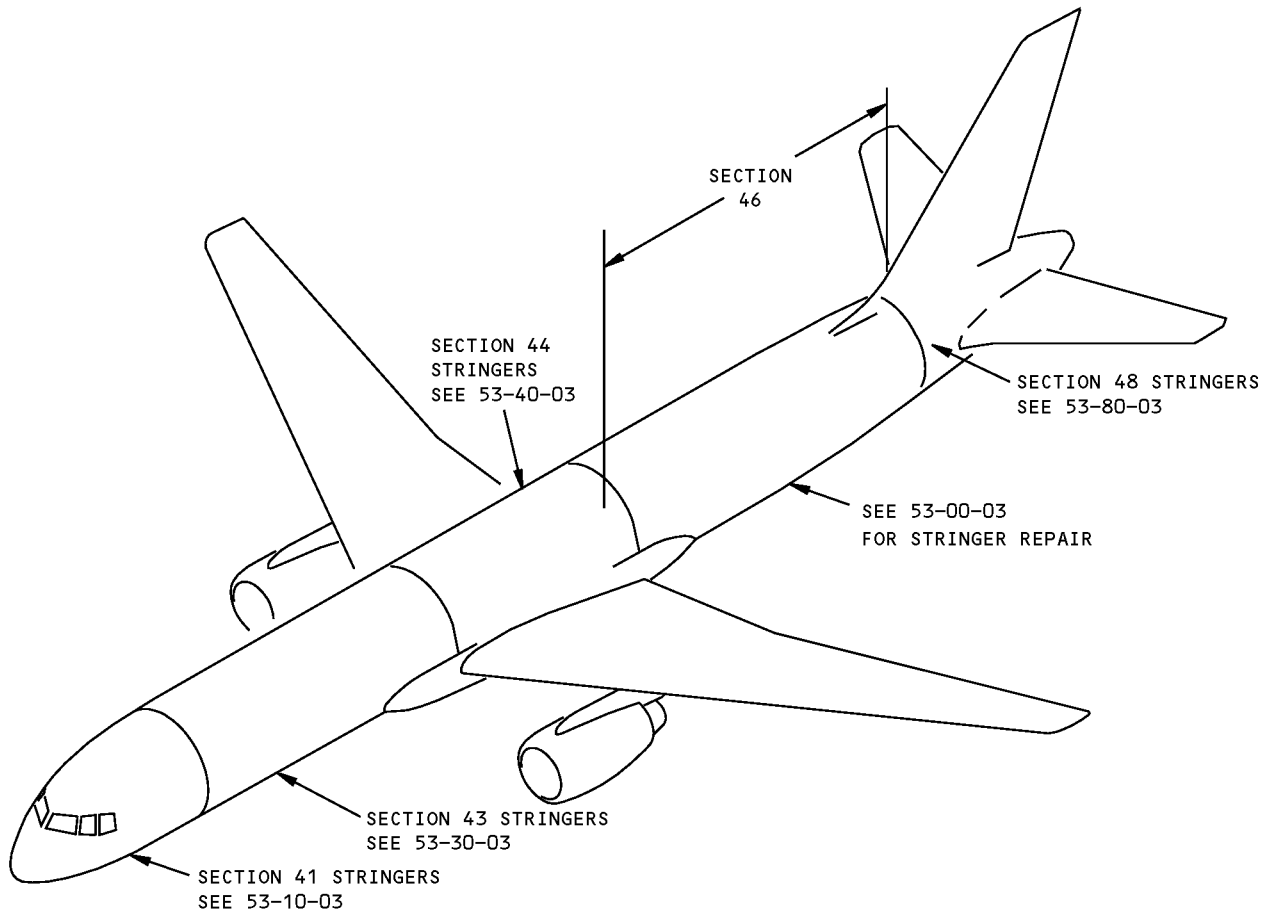
D634N201

ALLOWABLE DAMAGE GENERAL
Page 101
53-60-03
Jan 20/2007



757-200
STRUCTURAL REPAIR MANUAL

REPAIR GENERAL - SECTION 46 - STRINGERS



Section 46 Stringer Repair
Figure 201

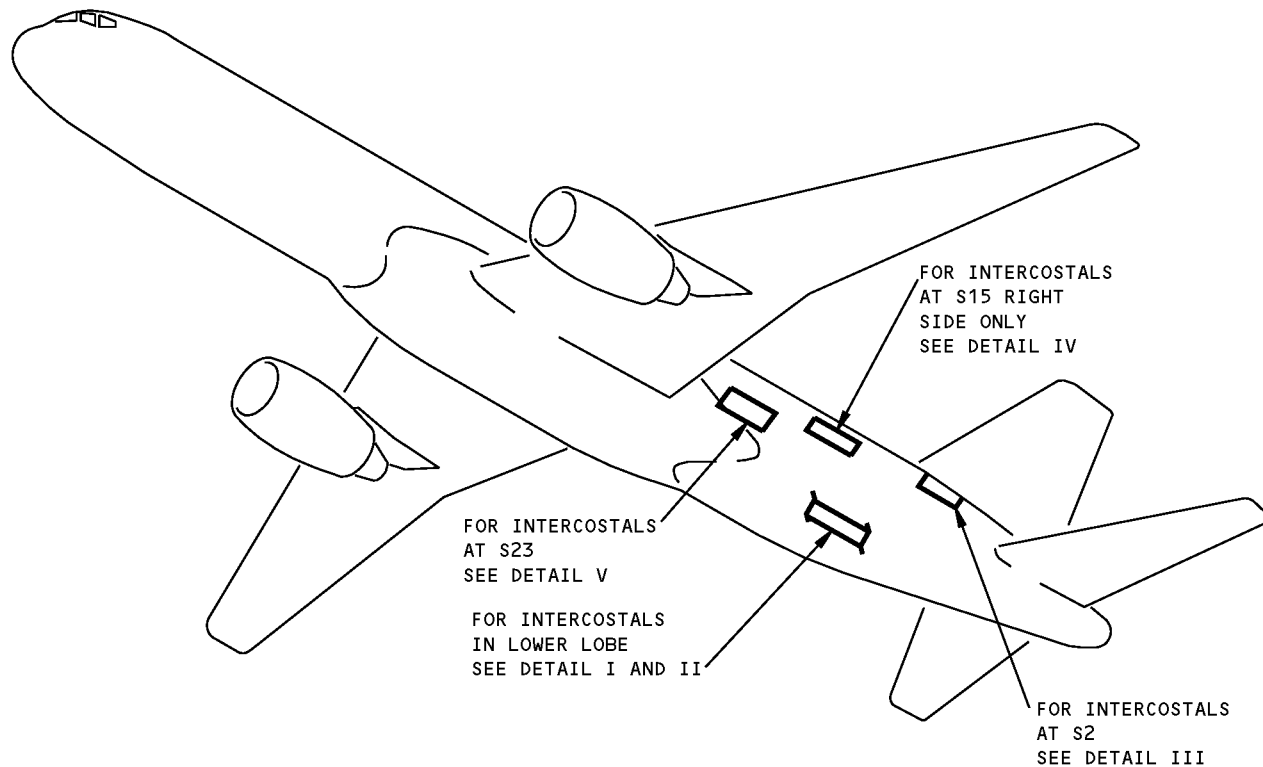
D634N201

53-60-03

REPAIR GENERAL
Page 201
Jan 20/2005

757-200
STRUCTURAL REPAIR MANUAL

IDENTIFICATION 1 - SECTION 46 - INTERCOSTALS



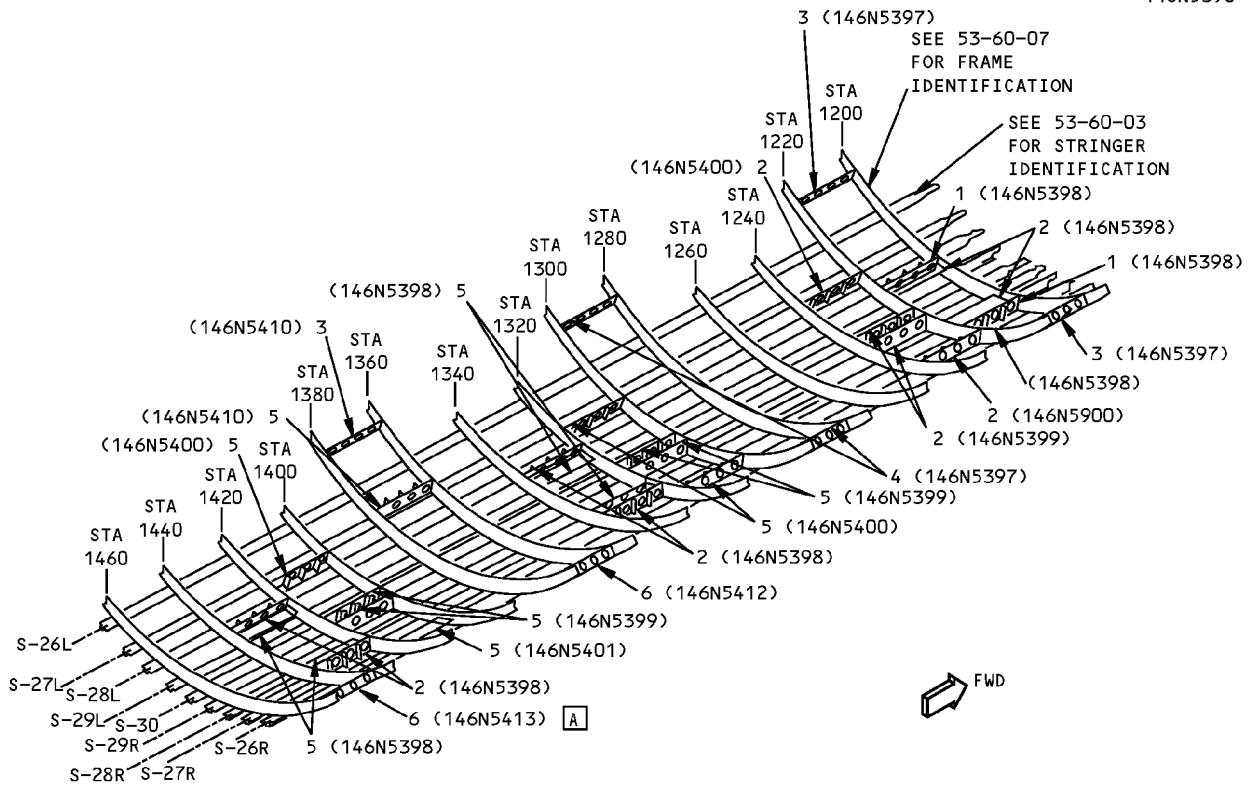
NOTES

- A** FOR CUM LINE NUMBERS:
1 THRU 5,9,10,11,13,14,16,23,25,28,34 THRU 37,
39,41,87,88,93, (BOEING REF. NO. NA220 THRU NA399)
- B** FOR CUM LINE NUMBERS:
9,10,11,13,14,16,23,25,28,34 THRU 37,39,41,87,88,
93, (BOEING REF. NO. NA220 THRU NA399)
- C** FOR ALL AIRPLANES NOT IN **B**

Section 46 Intercostal Identification
Figure 1 (Sheet 1 of 4)

757-200 STRUCTURAL REPAIR MANUAL

REF DWG
146N5390



DETAIL I

ITEM	DESCRIPTION	GAGE	MATERIAL	EFFECTIVITY
1	INTERCOSTAL	0.050	CLAD 7075-T6	
2	INTERCOSTAL	0.040	CLAD 7075-T6	
3	INTERCOSTAL WEB CHORD	0.040	CLAD 7075-T6 BAC1490-2828 CLAD 7075-T6	
4	INTERCOSTAL WEB CHORD	0.032	CLAD 7075-T6 BAC1490-2828 CLAD 7075-T6	
5	INTERCOSTAL	0.032	CLAD 7075-T6	
6	INTERCOSTAL WEB CHORD	0.040 0.050	CLAD 7075-T6 CLAD 7075-T6	

LIST OF MATERIALS FOR DETAIL I

**Section 46 Intercostal Identification
Figure 1 (Sheet 2 of 4)**

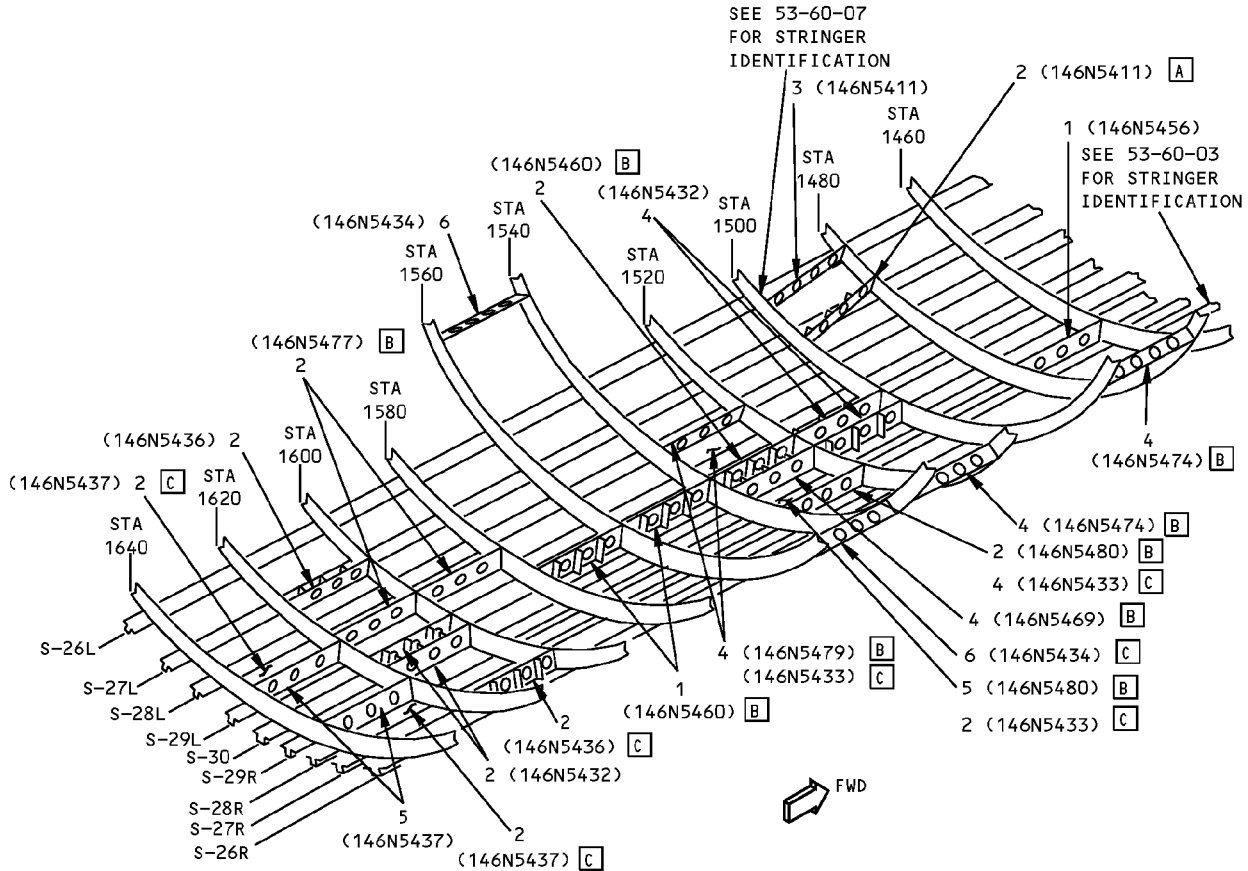
IDENTIFICATION 1
Page 2
Jan 20/2005

53-60-04

D634N201

757-200 STRUCTURAL REPAIR MANUAL

REF DWG
146N5390



DETAIL II

ITEM	DESCRIPTION	GAGE	MATERIAL	EFFECTIVITY
1	INTERCOSTAL WEB CHORD	0.040	CLAD 7075-T6 BAC1505-100052 7075-T6511	
2	INTERCOSTAL	0.040	CLAD 7075-T6	
3	INTERCOSTAL WEB CHORD	0.040	CLAD 7075-T6 BAC1490-2828 CLAD 7075-T6	
4	INTERCOSTAL	0.032	CLAD 7075-T6	
5	INTERCOSTAL	0.050	CLAD 7075-T6	
6	INTERCOSTAL WEB CHORD	0.032 0.050	CLAD 7075-T6 CLAD 7075-T6	

LIST OF MATERIALS FOR DETAIL II

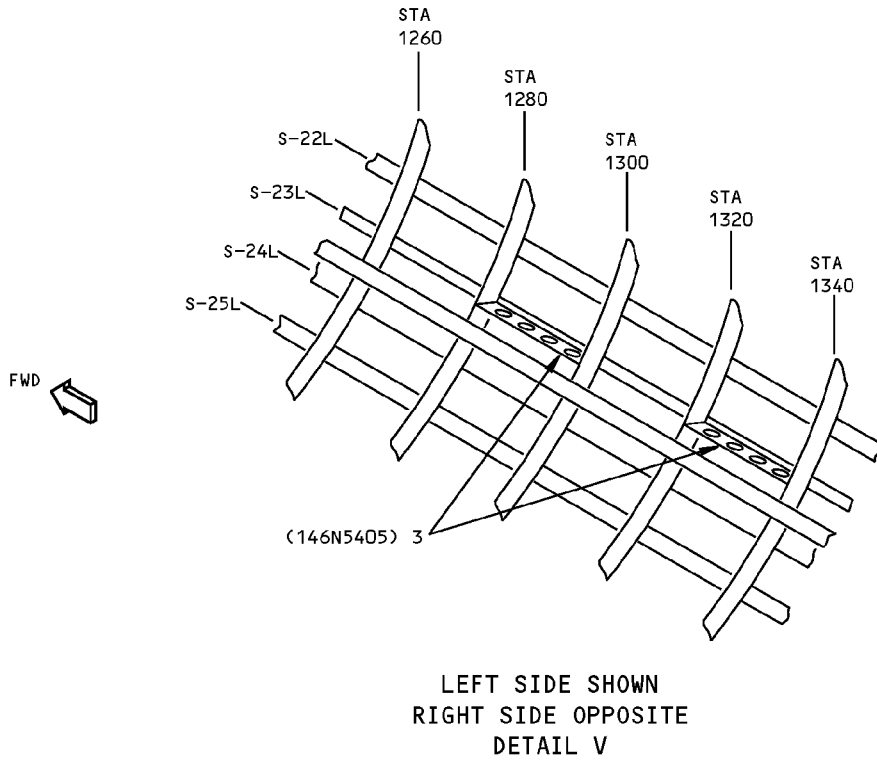
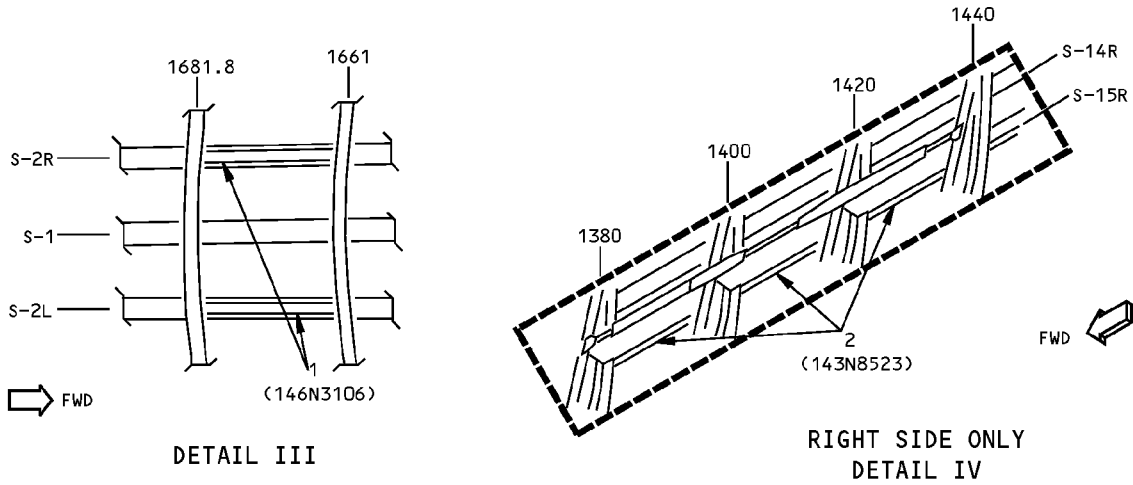
**Section 46 Intercostal Identification
Figure 1 (Sheet 3 of 4)**

IDENTIFICATION 1
Page 3
Jan 20/2005

53-60-04

D634N201

**757-200
STRUCTURAL REPAIR MANUAL**



ITEM	DESCRIPTION	GAGE	MATERIAL	EFFECTIVITY
1	INTERCOSTAL	0.050	CLAD 2024-T42	
2	INTERCOSTAL	0.040	CLAD 7075-T6	
3	INTERCOSTAL	0.063	CLAD 7075-T6	

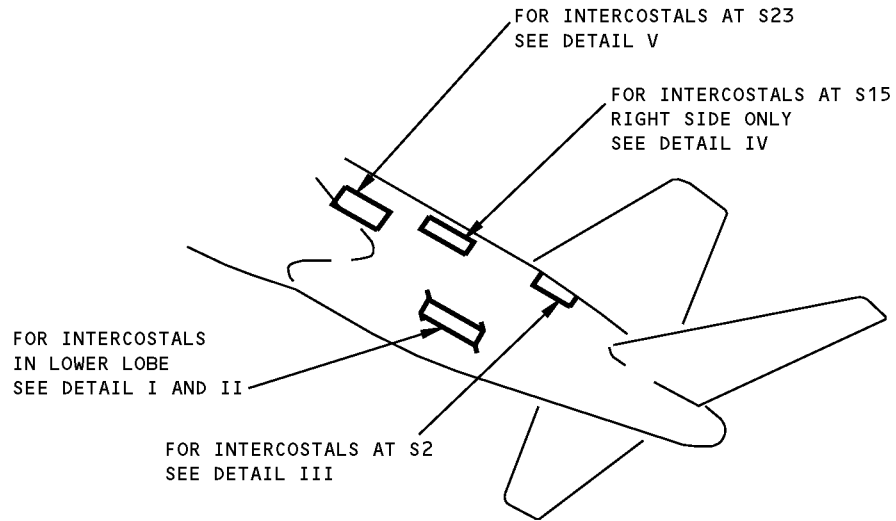
LIST OF MATERIALS FOR DETAILS III, IV AND V

**Section 46 Intercostal Identification
Figure 1 (Sheet 4 of 4)**



757-200
STRUCTURAL REPAIR MANUAL

ALLOWABLE DAMAGE GENERAL - SECTION 46 - INTERCOSTALS



NOTES

- REFER TO 53-00-04 FOR INTERCOSTAL ALLOWABLE DAMAGE DATA

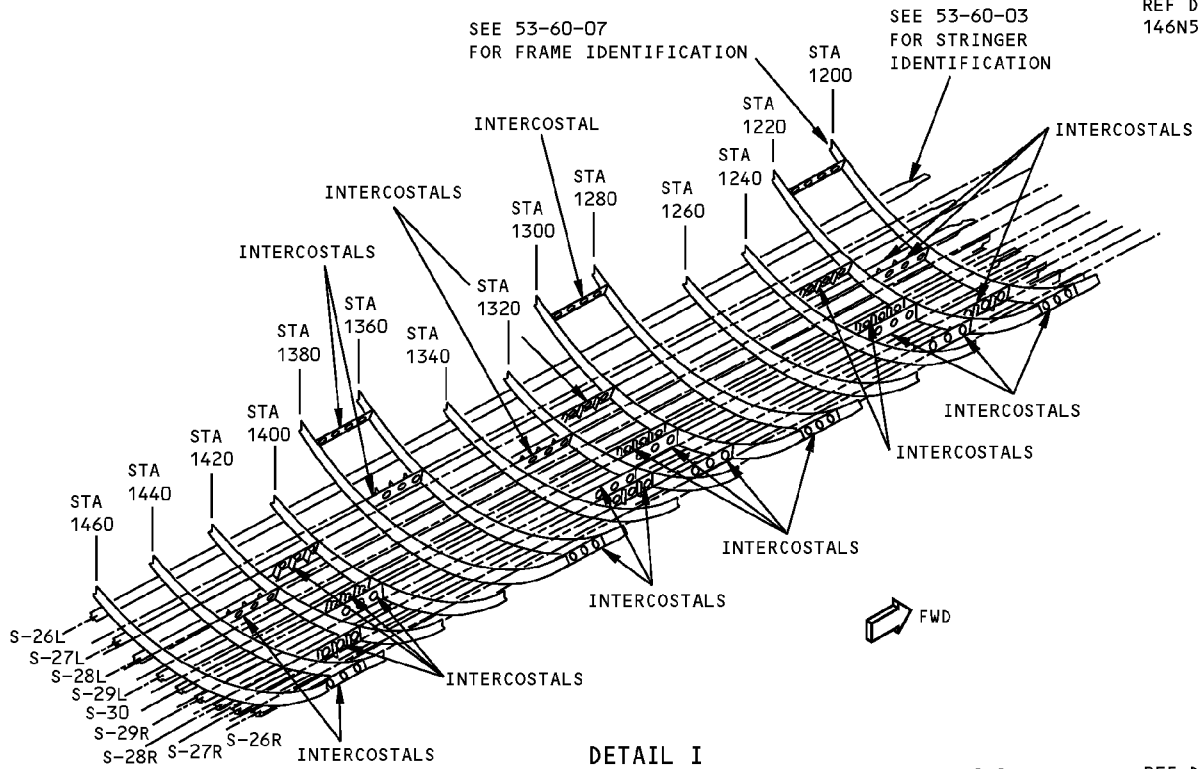
Section 46 Intercostal Allowable Damage
Figure 101 (Sheet 1 of 3)

D634N201

ALLOWABLE DAMAGE GENERAL
Page 101
53-60-04 Jan 20/2007

**757-200
STRUCTURAL REPAIR MANUAL**

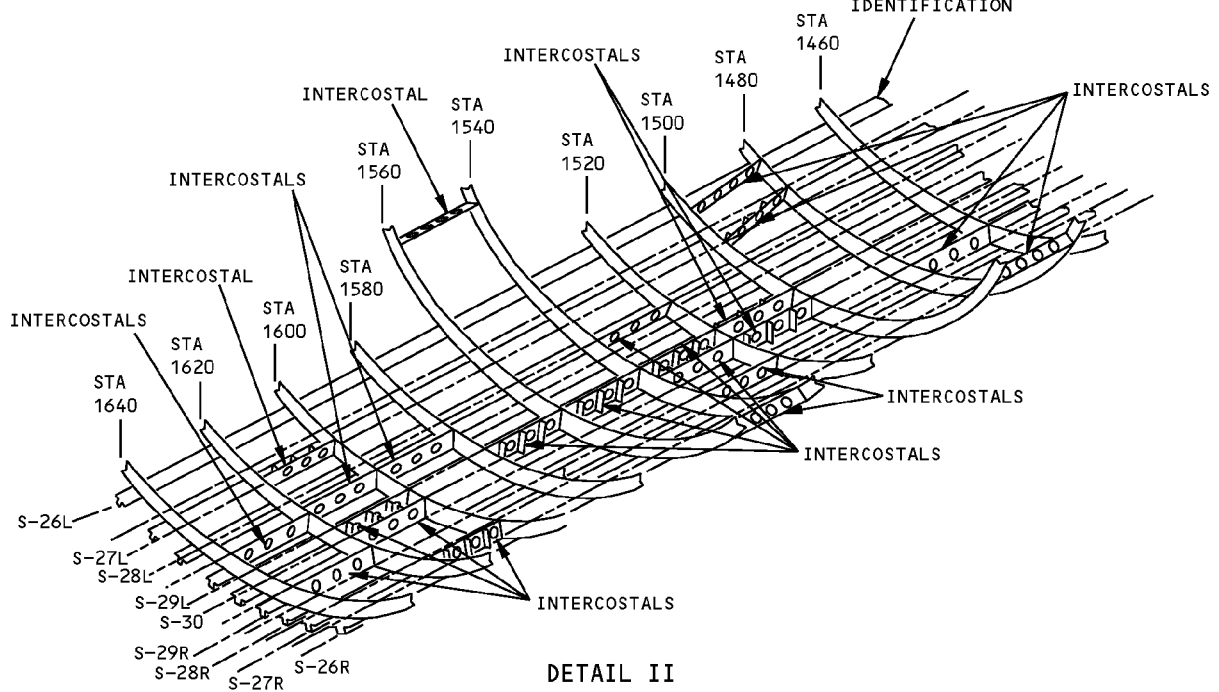
REF DWG
146N5390



DETAIL I

SEE 53-60-03
FOR STRINGER
IDENTIFICATION

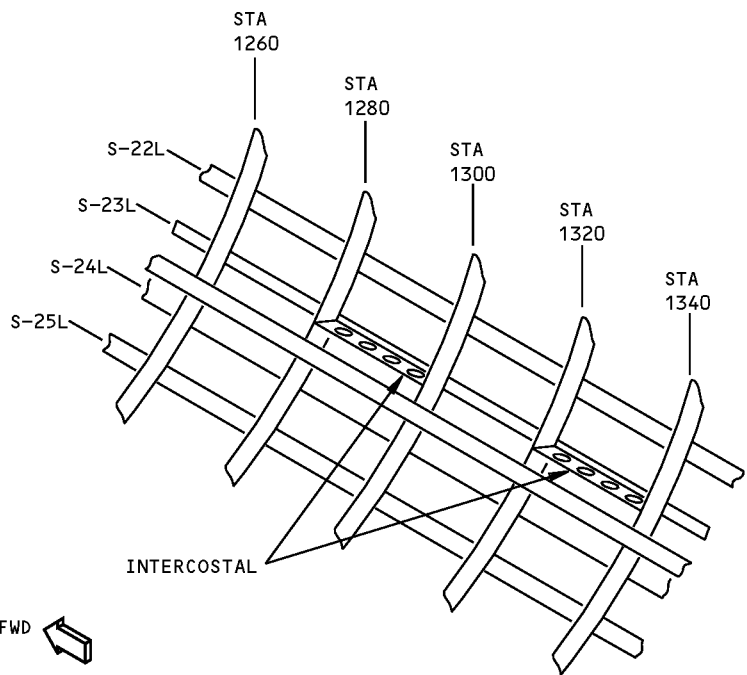
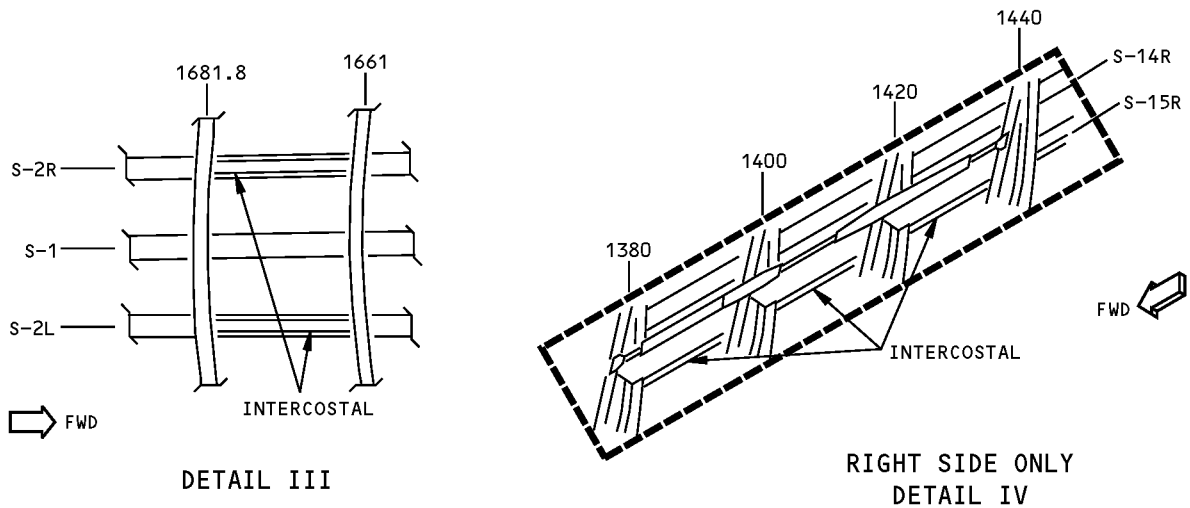
REF DWG
146N5390



DETAIL II

**Section 46 Intercostal Allowable Damage
Figure 101 (Sheet 2 of 3)**

**757-200
STRUCTURAL REPAIR MANUAL**

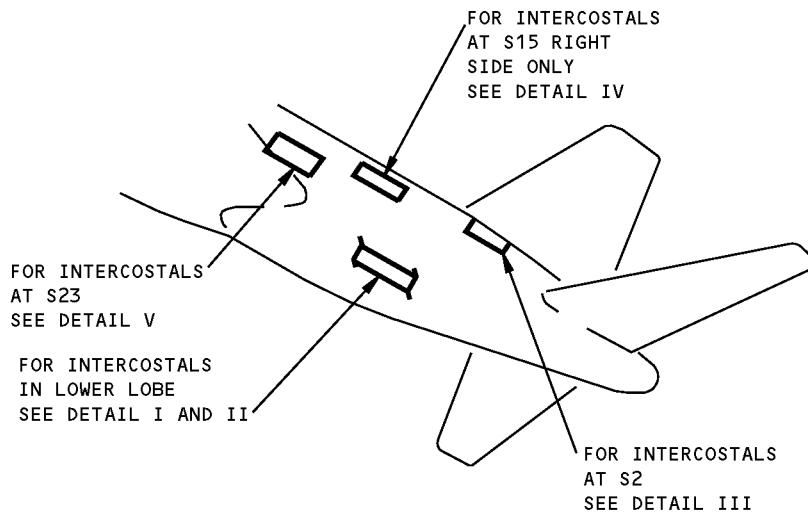


LEFT SIDE SHOWN
RIGHT SIDE OPPOSITE
DETAIL V

**Section 46 Intercostal Allowable Damage
Figure 101 (Sheet 3 of 3)**

757-200
STRUCTURAL REPAIR MANUAL

REPAIR GENERAL - SECTION 46 - INTERCOSTALS



NOTES

- DAMAGED INTERCOSTAL COMPONENTS MAY BE REPLACED OR REPAIRED. IF REPAIRS ARE TO BE MADE, SEE 51-70 FOR TYPICAL WEB, FORMED SECTION, OR EXTRUDED SECTION REPAIRS.

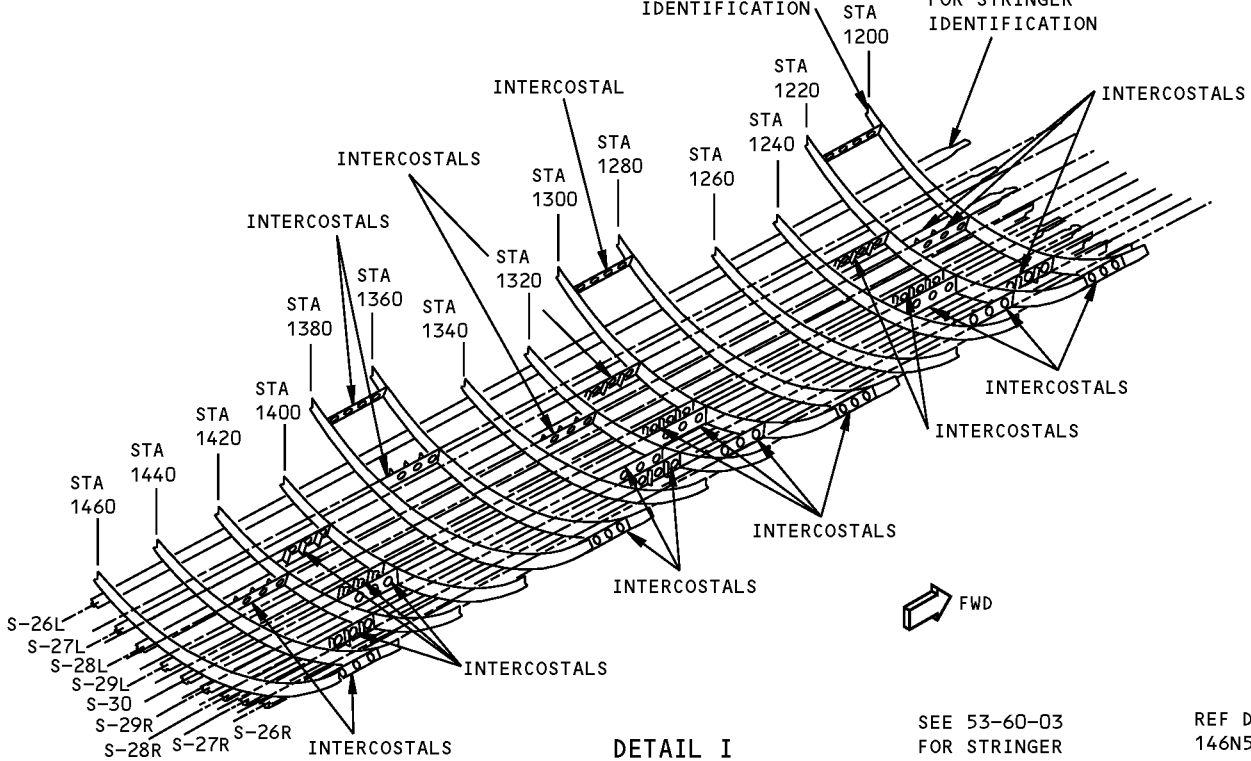
Section 46 Intercostals Repair
Figure 201 (Sheet 1 of 3)

**757-200
STRUCTURAL REPAIR MANUAL**

SEE 53-60-07
FOR FRAME
IDENTIFICATION

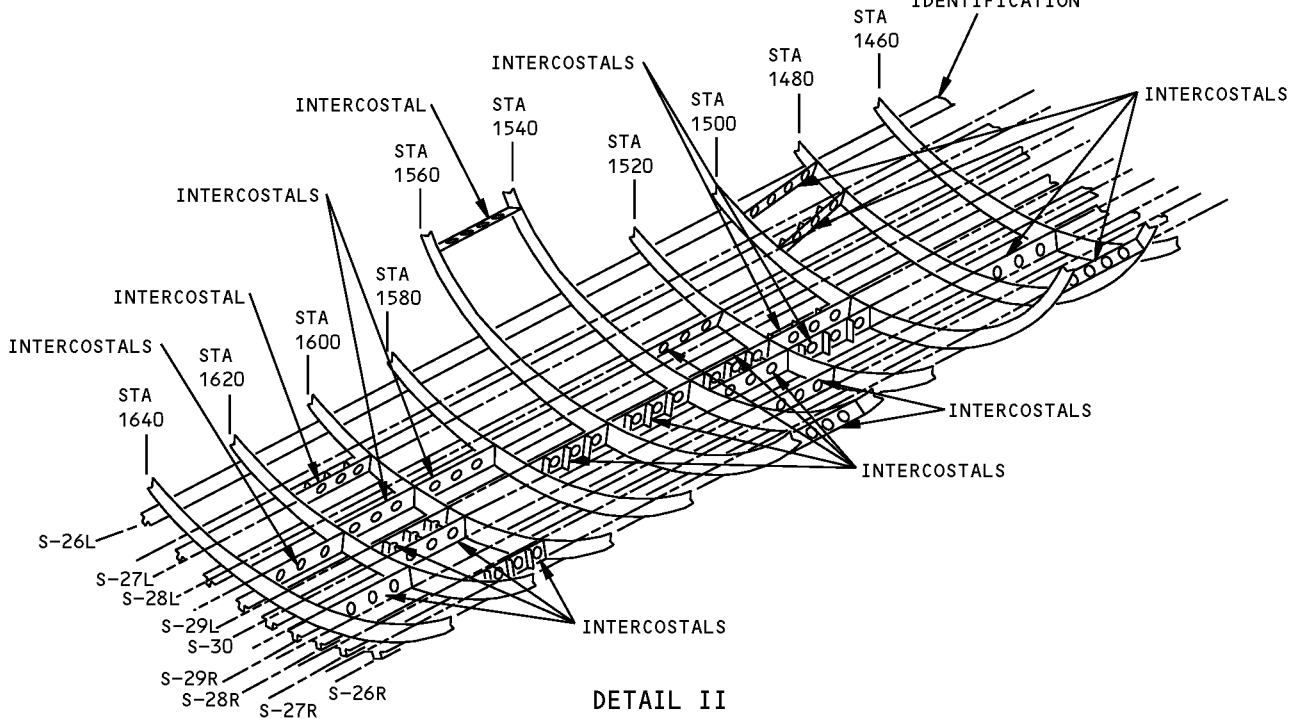
SEE 53-60-03
FOR STRINGER
IDENTIFICATION

REF DWG
146N5390



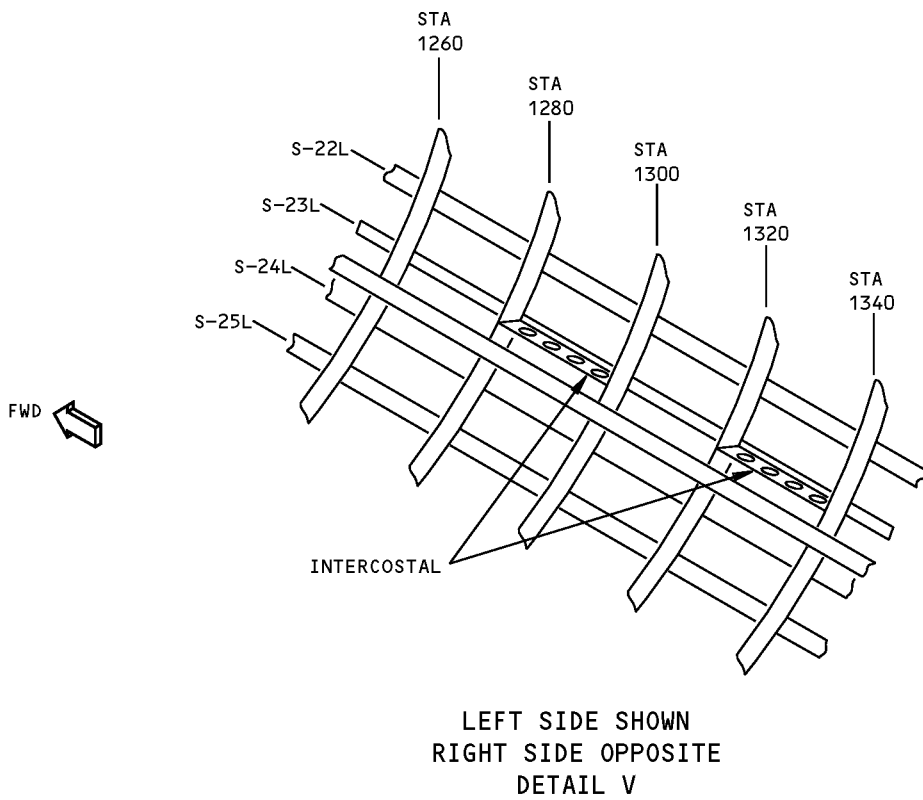
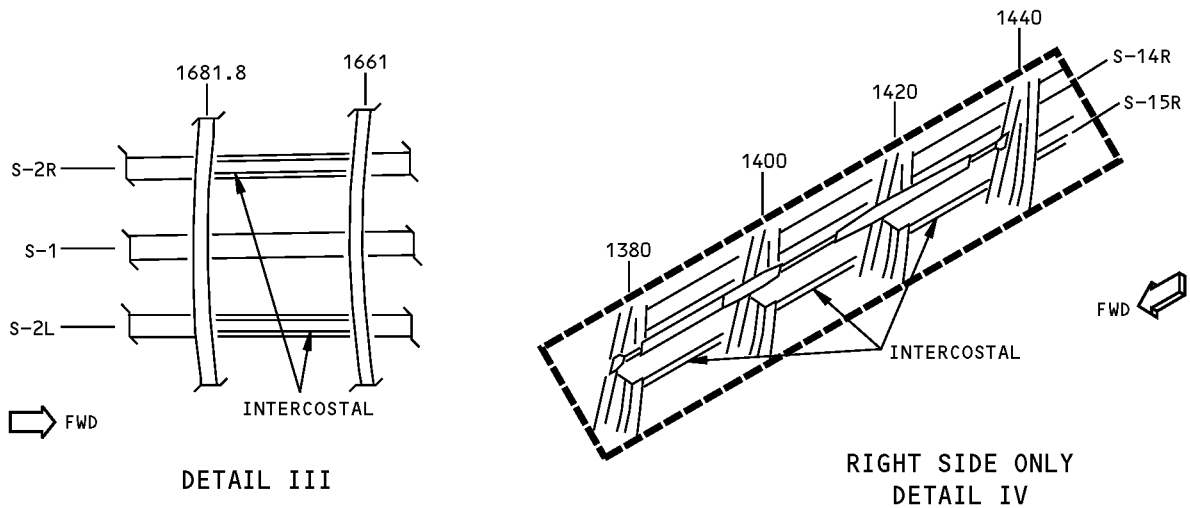
SEE 53-60-03
FOR STRINGER
IDENTIFICATION

REF DWG
146N5390



**Section 46 Intercostals Repair
Figure 201 (Sheet 2 of 3)**

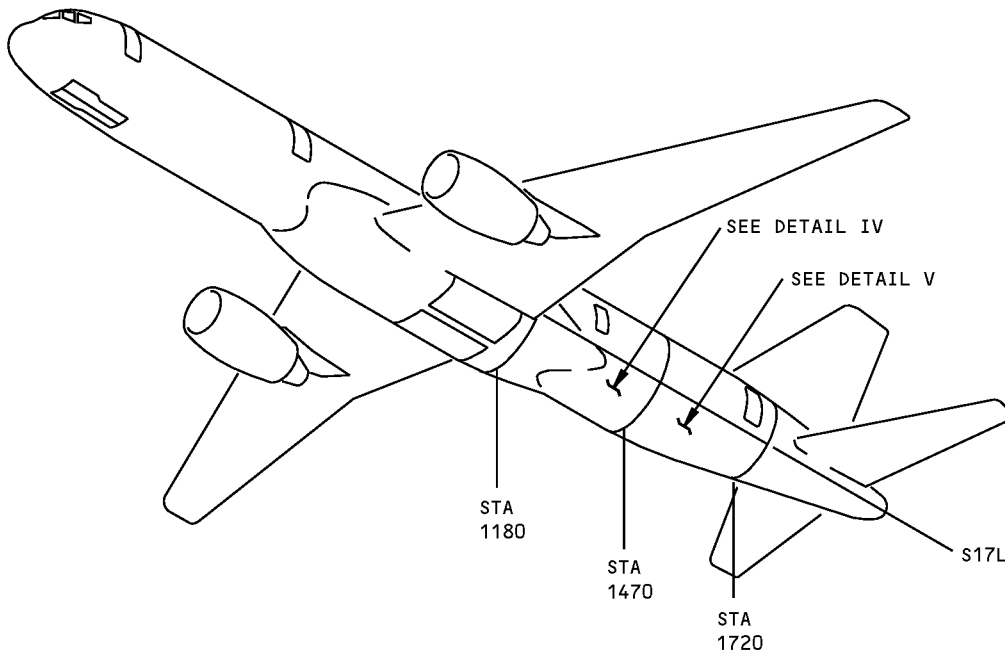
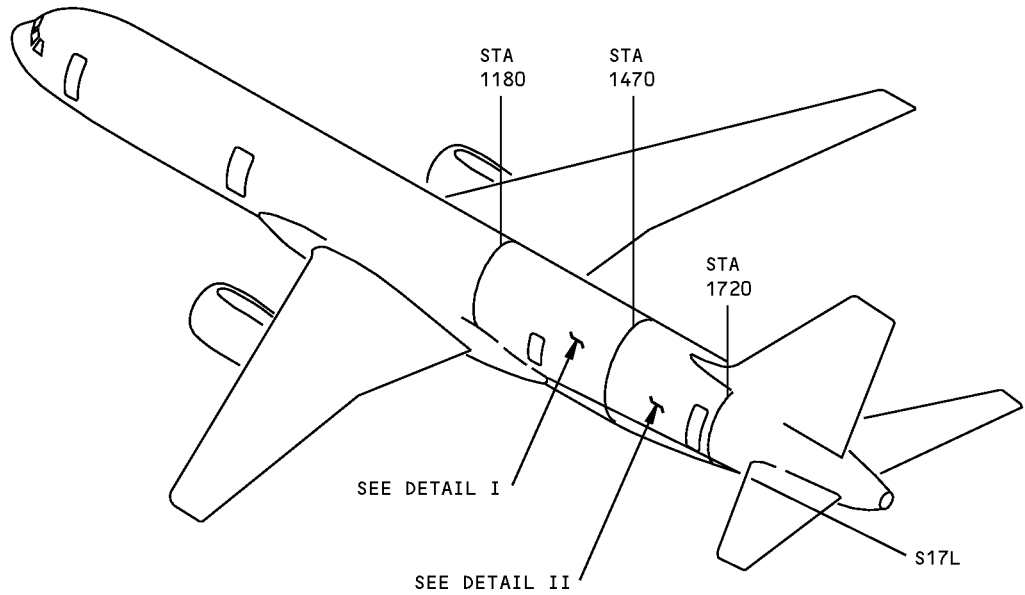
**757-200
STRUCTURAL REPAIR MANUAL**



**Section 46 Intercostals Repair
Figure 201 (Sheet 3 of 3)**

**757-200
STRUCTURAL REPAIR MANUAL**

IDENTIFICATION 1 - SECTION 46 - FRAMES



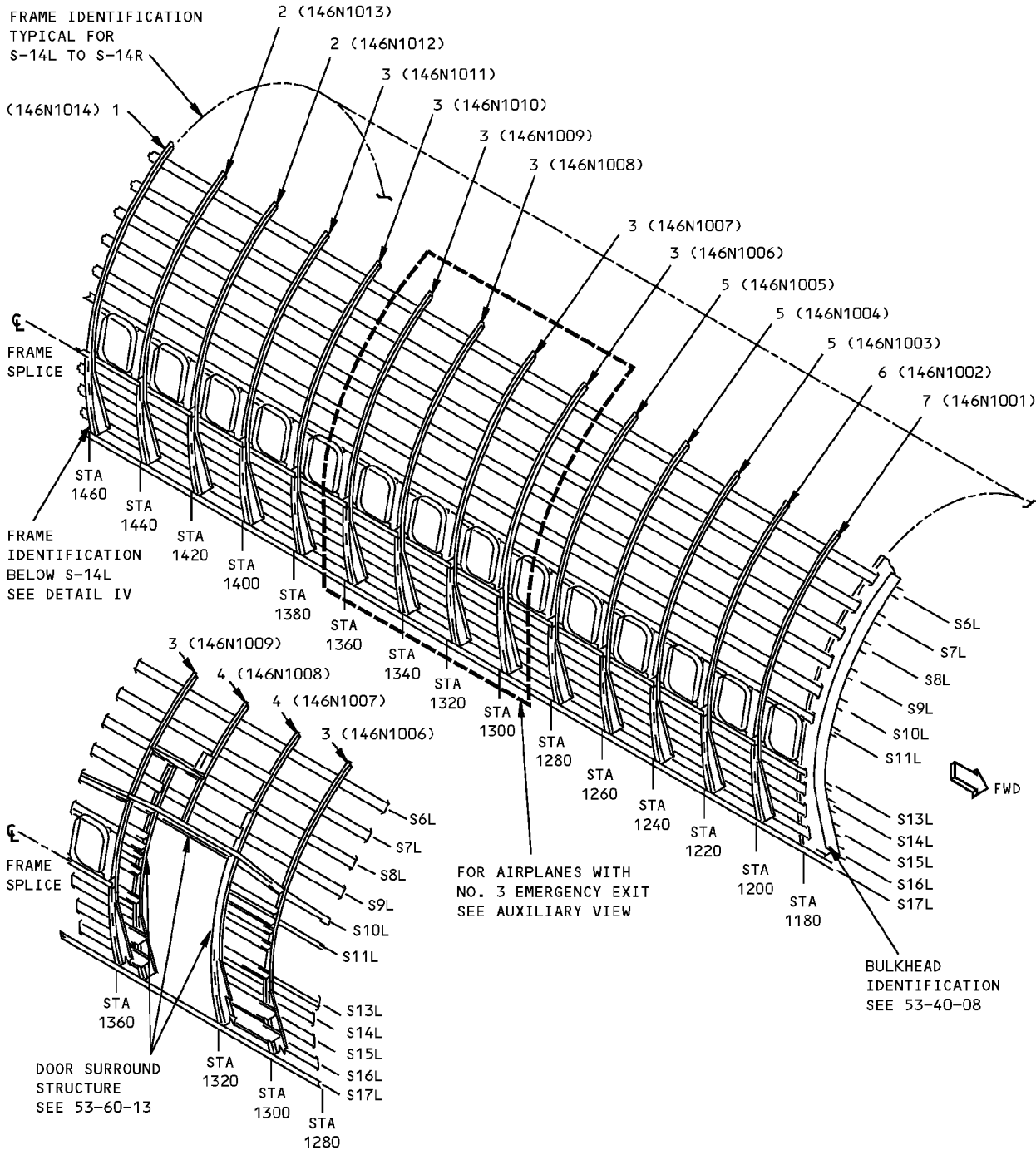
NOTES

- [A]** FOR CUM LINE NUMBERS: 1 THRU 5
- [B]** FOR ALL AIRPLANES NOT IN **[A]**
- [C]** S-14R THRU S-27R

- [D]** S-19 THRU S-24
- [E]** FOR CUM LINE NUMBERS: 1 THRU 719
- [E]** FOR CUM LINE NUMBERS: 720 AND ON

**Section 46 Frame Identification
Figure 1 (Sheet 1 of 11)**

**757-200
STRUCTURAL REPAIR MANUAL**



**AIRPLANES WITH NO. 3 EMERGENCY EXIT
AUXILIARY VIEW**

**LEFT SIDE SHOWN RIGHT SIDE OPPOSITE
DETAIL I**

**Section 46 Frame Identification
Figure 1 (Sheet 2 of 11)**



**757-200
STRUCTURAL REPAIR MANUAL**

ITEM	DESCRIPTION	GAGE	MATERIAL	EFFECTIVITY
1	FRAME	0.063	BAC1517-2155 CLAD 7075-T6	
2	FRAME		BAC1517-2157 CLAD 7075-T6	
3	FRAME		BAC1517-2158 CLAD 7075-T6	
4	FRAME		CLAD 7075-T6	
5	FRAME		BAC1517-2159 CLAD 7075-T6	
6	FRAME		BAC1517-2160 CLAD 7075-T6	
7	FRAME		BAC1517-2161 CLAD 7075-T6	

LIST OF MATERIALS FOR DETAIL I

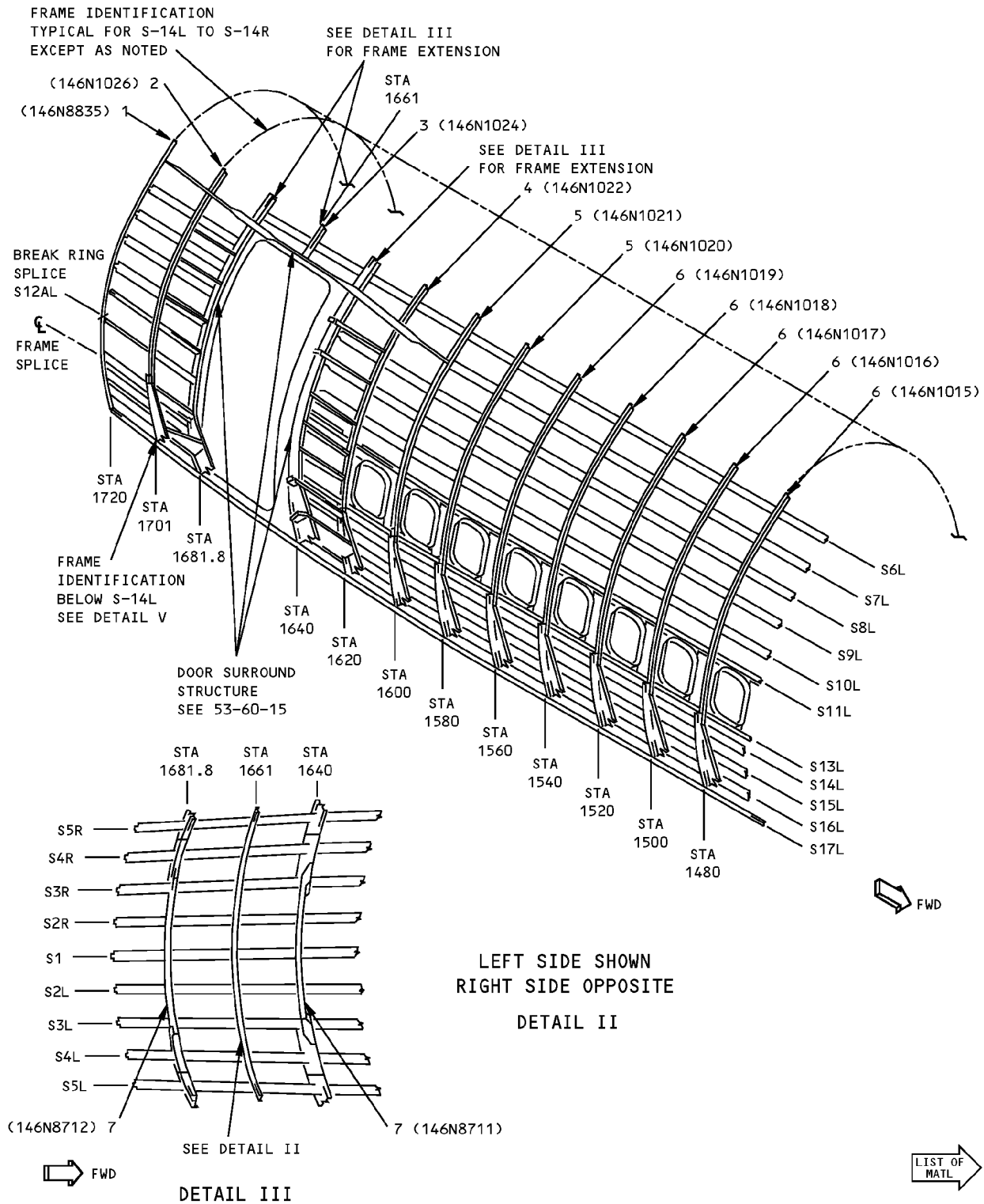
**Section 46 Frame Identification
Figure 1 (Sheet 3 of 11)**

D634N201

53-60-07

IDENTIFICATION 1
Page 3
Jan 20/2005

**757-200
STRUCTURAL REPAIR MANUAL**



LEFT SIDE SHOWN
RIGHT SIDE OPPOSITE
DETAIL II

**Section 46 Frame Identification
Figure 1 (Sheet 4 of 11)**



**757-200
STRUCTURAL REPAIR MANUAL**

ITEM	DESCRIPTION	GAGE	MATERIAL	EFFECTIVITY
1	BREAK RING		BAC1514-1477 7075-T73 BAC1514-1477 7075-T6	A B
2	FRAME ASSY FRAME CHORD	0.090	CLAD 7075-T6 BAC1490-2770 7075-T6	
3	FRAME ASSY FRAME CHORD	0.080	CLAD 7075-T6 BAC1490-2770 7075-T6	
4	FRAME		BAC1517-2155 CLAD 7075-T6	
5	FRAME	0.056	CLAD 7075-T6 BAC1517-2155 CLAD 7075-T6	E F
6	FRAME		BAC1517-2157 CLAD 7075-T6	
7	FRAME ASSY FAILSAFE ANGLE WEB		BAC1490-2770 7075-T6 BAC1517-2159 7075-T6	

LIST OF MATERIALS FOR DETAILS II AND III

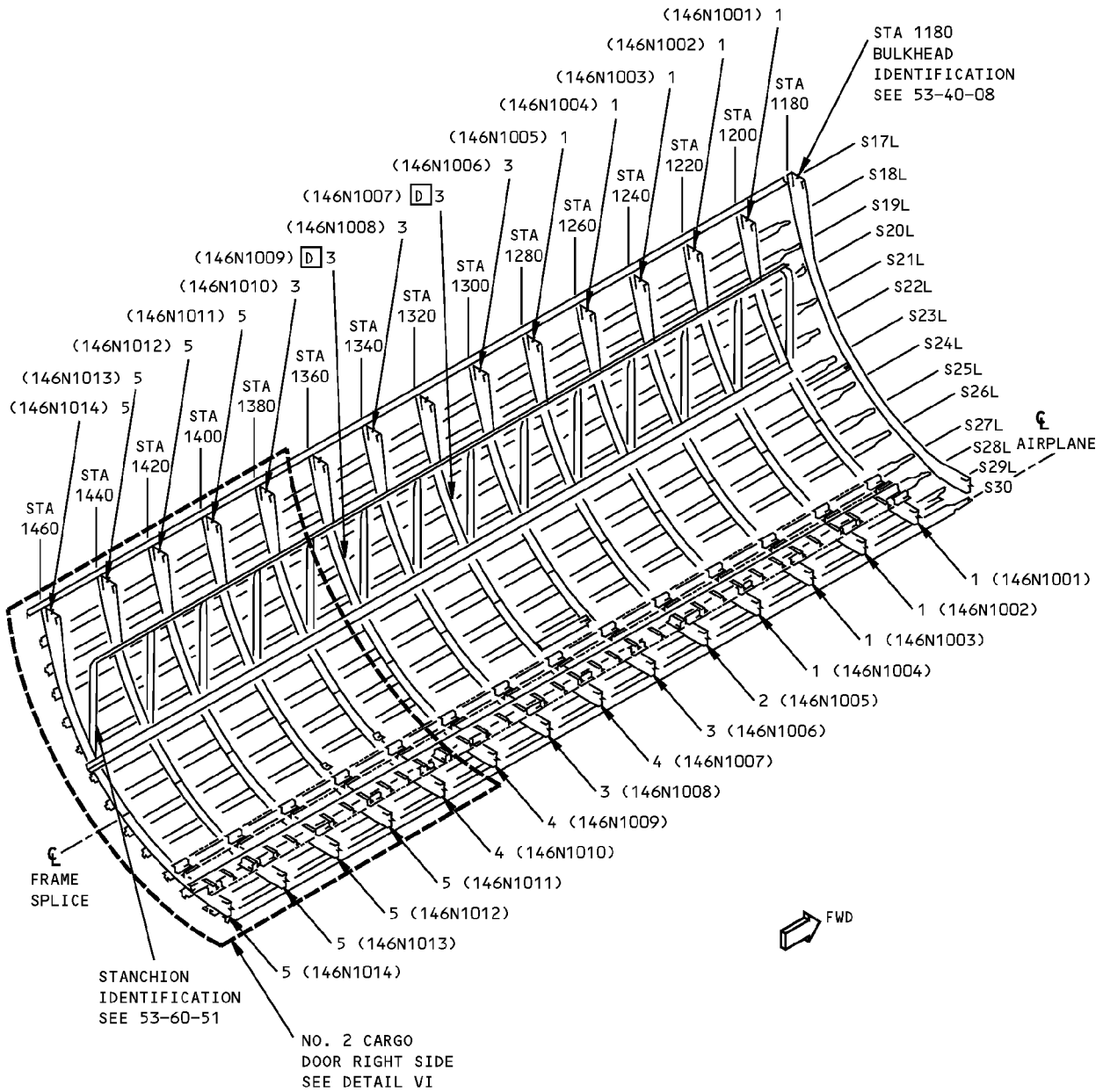
**Section 46 Frame Identification
Figure 1 (Sheet 5 of 11)**

D634N201

53-60-07

IDENTIFICATION 1
Page 5
Jan 20/2005

**757-200
STRUCTURAL REPAIR MANUAL**



LEFT SIDE SHOWN
RIGHT SIDE OPPOSITE
EXCEPT AS NOTED

DETAIL IV



**Section 46 Frame Identification
Figure 1 (Sheet 6 of 11)**



757-200
STRUCTURAL REPAIR MANUAL

ITEM	DESCRIPTION	GAGE	MATERIAL	EFFECTIVITY
1	FRAME ASSY FRAME CHORD	0.080	CLAD 7075-T6 BAC1490-2770 7075-T6	
2	FRAME ASSY FRAME CHORD	0.080	CLAD 7075-T6 BAC1490-2763 7075-T6	
3	FRAME ASSY FRAME CHORD	0.071	CLAD 7075-T6 BAC1490-2770 7075-T6	
4	FRAME ASSY FRAME CHORD	0.071	CLAD 7075-T6 BAC1490-2847 7075-T6	
5	FRAME ASSY FRAME CHORD	0.063	CLAD 7075-T6 BAC1490-2763 7075-T6	

LIST OF MATERIALS FOR DETAIL IV

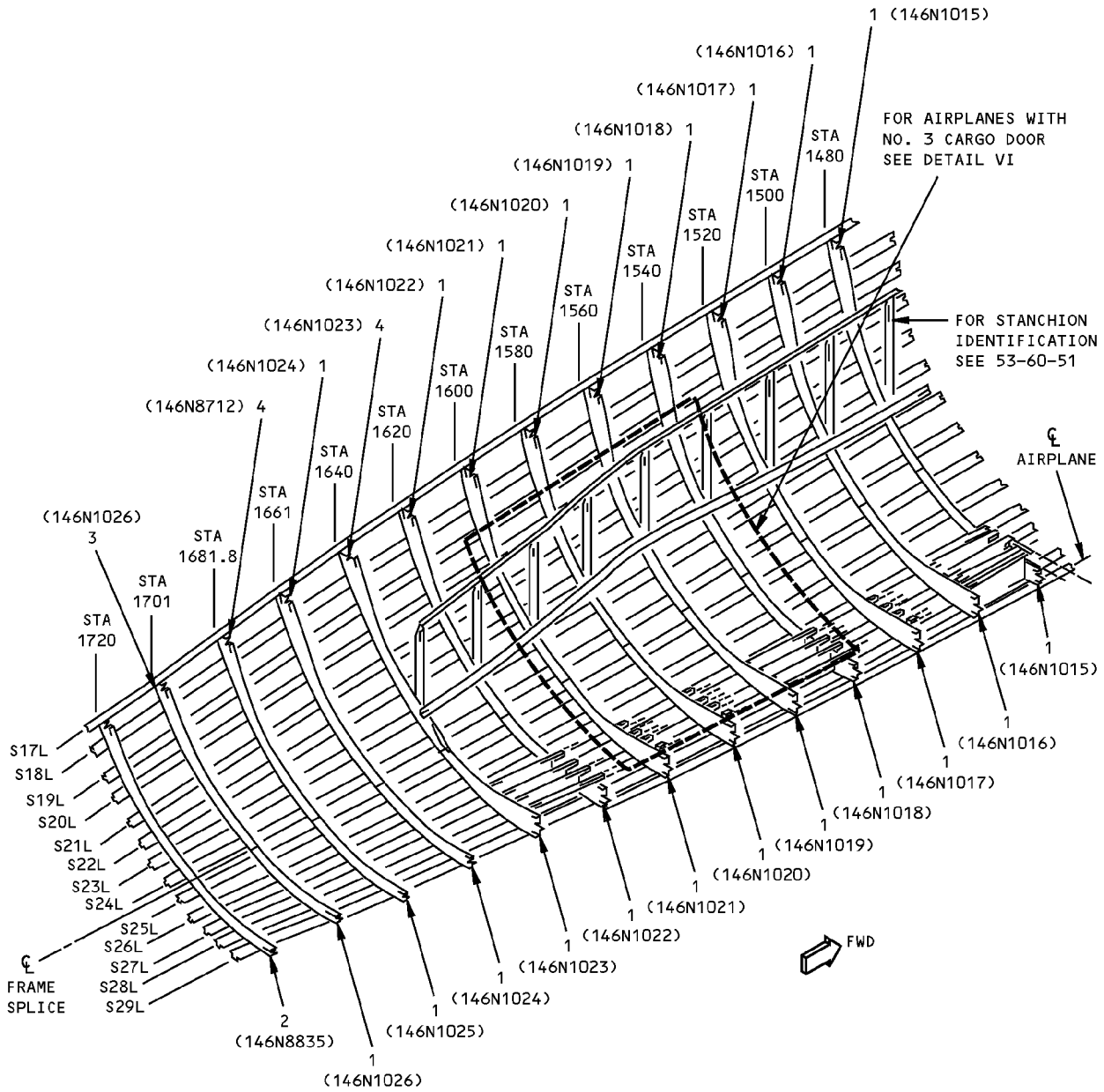
Section 46 Frame Identification
Figure 1 (Sheet 7 of 11)

D634N201

53-60-07

IDENTIFICATION 1
Page 7
Jan 20/2005

**757-200
STRUCTURAL REPAIR MANUAL**



LEFT SIDE SHOWN
RIGHT SIDE OPPOSITE EXCEPT AS NOTED

DETAIL V

**Section 46 Frame Identification
Figure 1 (Sheet 8 of 11)**

LIST OF MATL →



757-200
STRUCTURAL REPAIR MANUAL

ITEM	DESCRIPTION	GAGE	MATERIAL	EFFECTIVITY		
1	FRAME ASSY FRAME CHORD	0.063	CLAD 7075-T6 BAC1490-2763 7075-T6			
2	BREAK RING		BAC1514-1477 7075-T73 BAC1514-1477 7075-T6	<table border="1"><tr><td>A</td></tr><tr><td>B</td></tr></table>	A	B
A						
B						
3	FRAME ASSY FRAME CHORD	0.080	CLAD 7075-T6 BAC1490-2763 7075-T6			
4	FRAME ASSY CHORD WEB FAILSAFE ANGLE	 0.080	 BAC1514-2700 7075-T73 OPTIONAL; 7075-T73511 7075-T6 BAC1490-2770 7075-T6			

LIST OF MATERIALS FOR DETAIL V

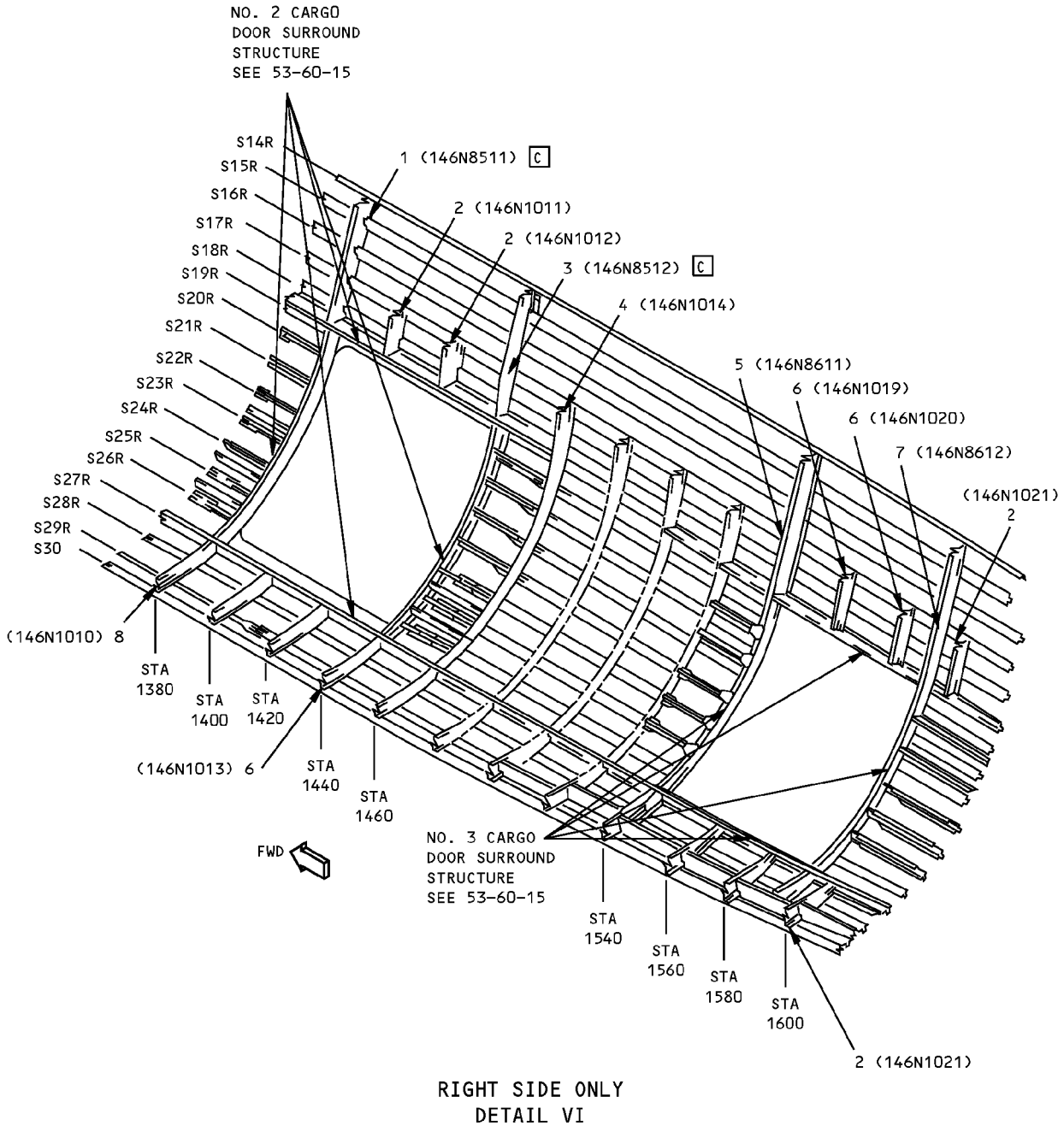
Section 46 Frame Identification
Figure 1 (Sheet 9 of 11)

D634N201

53-60-07

IDENTIFICATION 1
Page 9
Jan 20/2005

**757-200
STRUCTURAL REPAIR MANUAL**



LIST OF
MATERIAL

**Section 46 Frame Identification
Figure 1 (Sheet 10 of 11)**



**757-200
STRUCTURAL REPAIR MANUAL**

ITEM	DESCRIPTION	GAGE	MATERIAL	EFFECTIVITY
1	FRAME ASSY OUTER CHORD INNER CHORD WEB	0.071	BAC1503-100275 7075-T73 BAC1505-100849 7075-T73 7075-T6	
2	FRAME ASSY FRAME CHORD	0.071	CLAD 7075-T6 BAC1490-2763 7075-T6	
3	FRAME ASSY OUTER CHORD INNER CHORD WEB	0.071	BAC1503-100275 7075-T6 BAC1503-100698 7075-T6 7075-T6	
4	FRAME ASSY FRAME CHORD	0.063 0.090	CLAD 7075-T6 7075-T6	
5	FRAME ASSY OUTER CHORD INNER CHORD WEB	0.071	BAC1503-100744 7075-T73 BAC1505-100849 7075-T73 7075-T6	
6	FRAME ASSY FRAME CHORD	0.063	CLAD 7075-T6 BAC1490-2763 7075-T6	
7	FRAME ASSY OUTER CHORD INNER CHORD WEB	0.071	BAC1503-100744 7075-T73 BAC1503-100745 7075-T73 7075-T6	
8	FRAME ASSY FRAME CHORD	0.071	CLAD 7075-T6 BAC1490-2847 7075-T6	

LIST OF MATERIALS FOR DETAIL VI

**Section 46 Frame Identification
Figure 1 (Sheet 11 of 11)**

D634N201

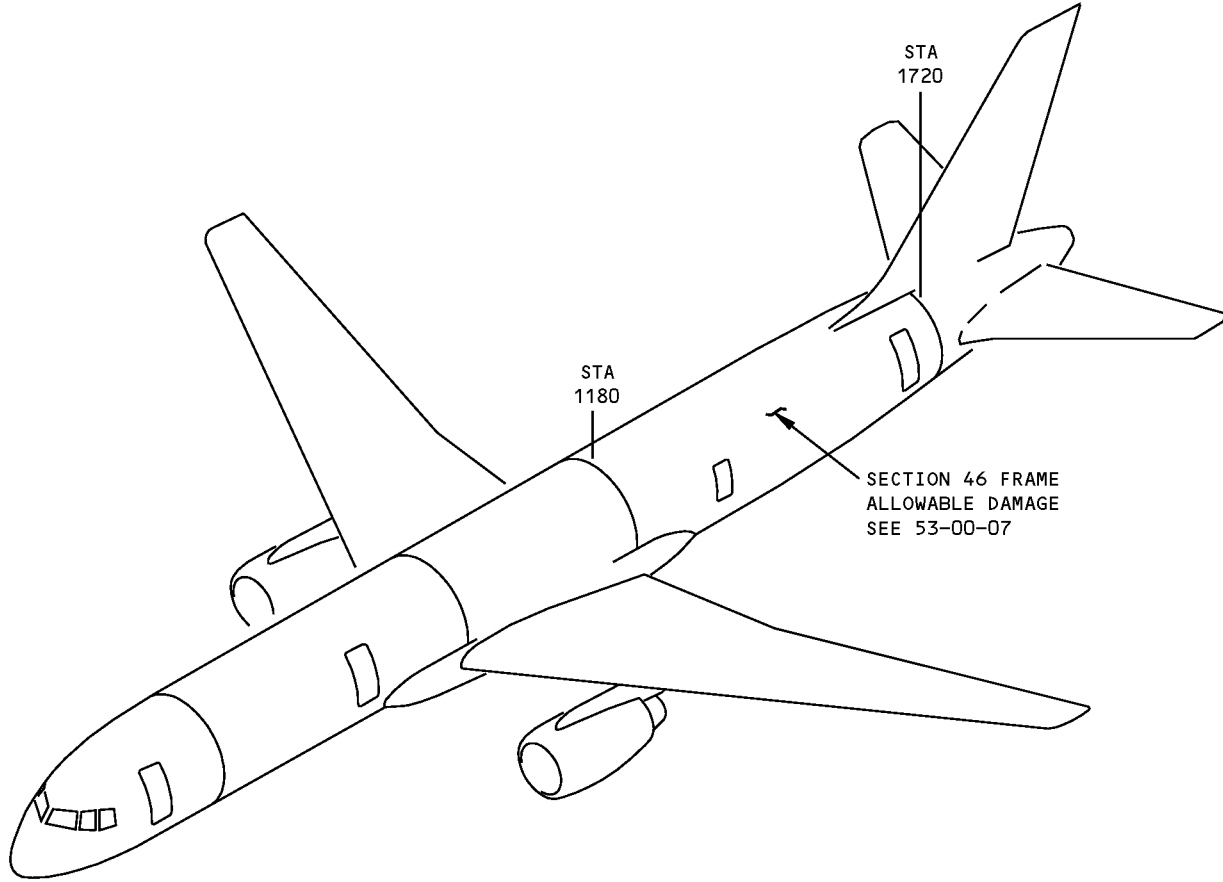
53-60-07

IDENTIFICATION 1
Page 11
Jan 20/2005



757-200
STRUCTURAL REPAIR MANUAL

ALLOWABLE DAMAGE GENERAL - SECTION 46 - FRAMES



Section 46 Frame Allowable Damage
Figure 101

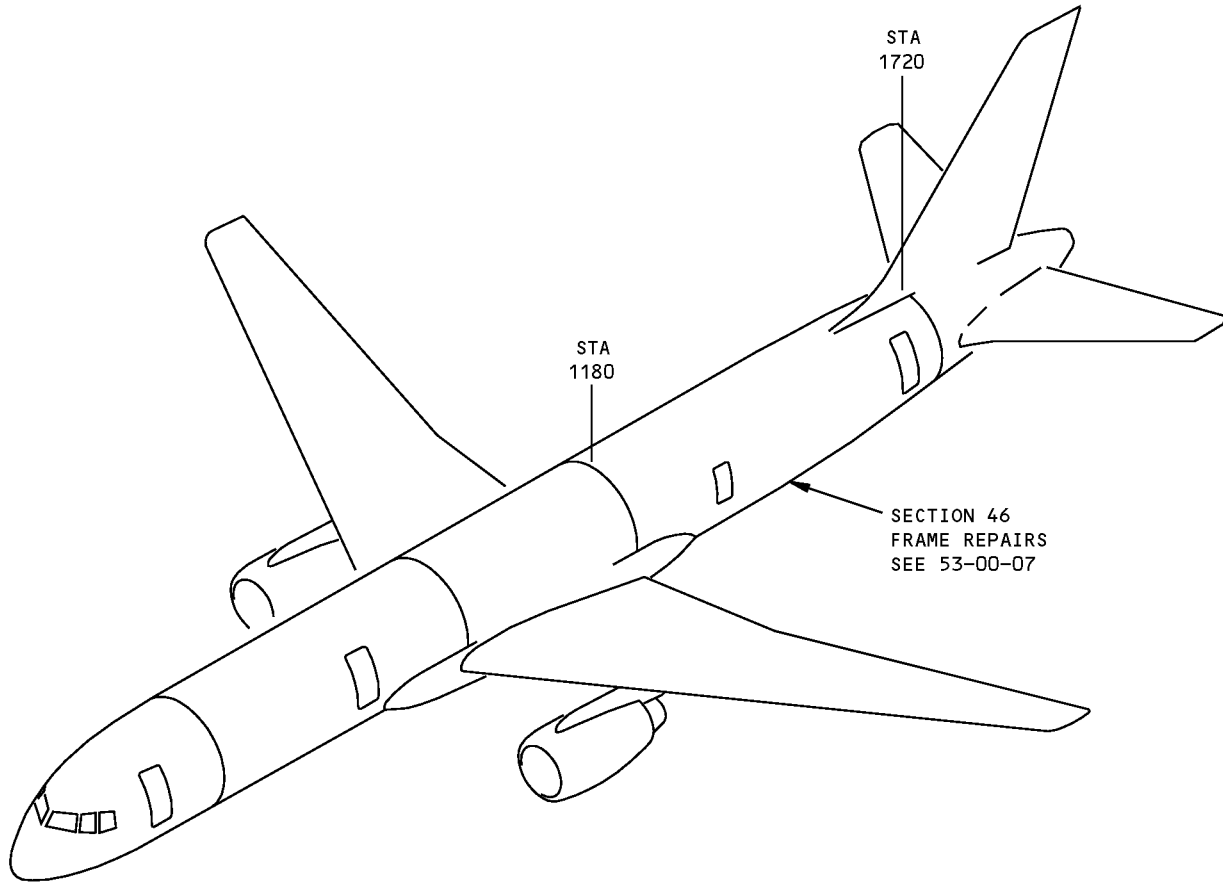
D634N201

ALLOWABLE DAMAGE GENERAL
Page 101
53-60-07
Jan 20/2005



757-200
STRUCTURAL REPAIR MANUAL

REPAIR GENERAL - SECTION 46 - FRAMES



Section 46 Fuselage Frame Repairs
Figure 201

D634N201

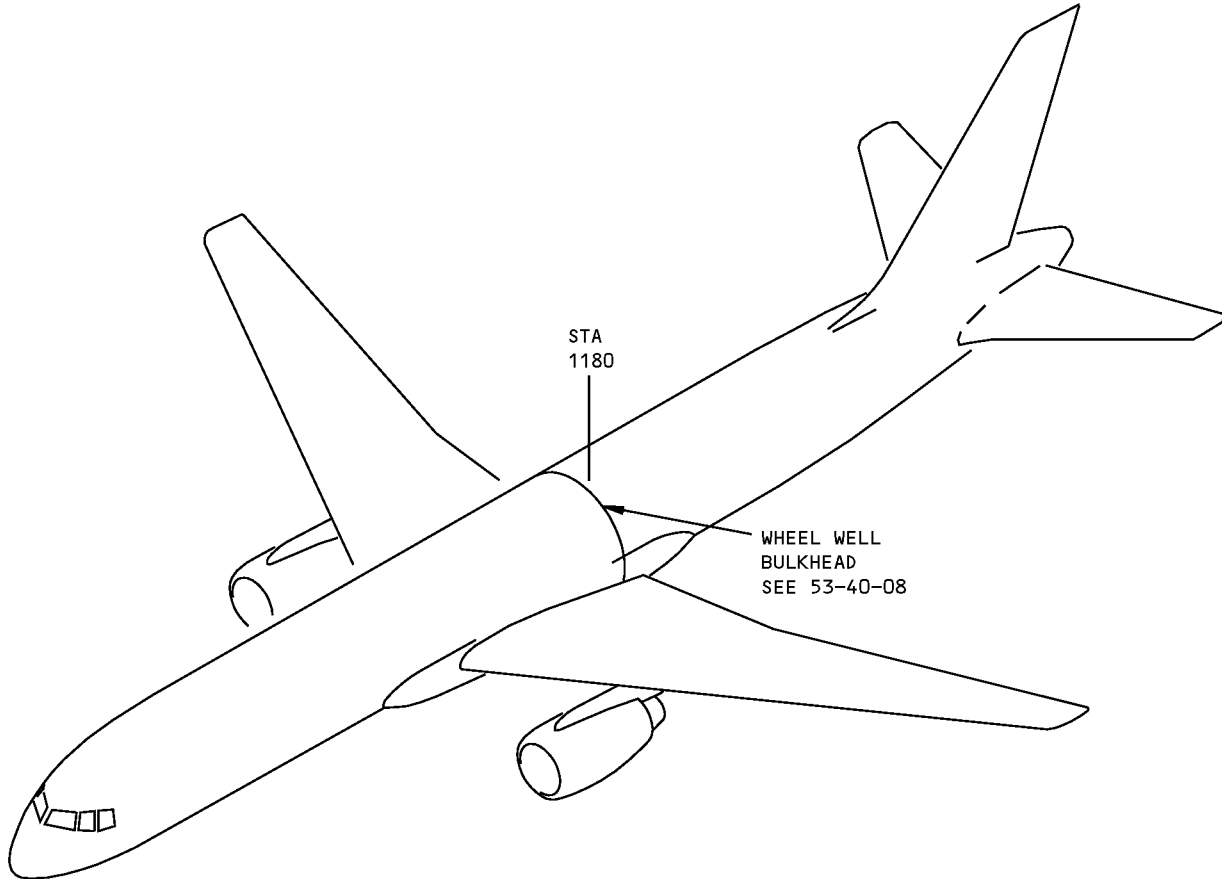
53-60-07

REPAIR GENERAL
Page 201
Jan 20/2005



757-200
STRUCTURAL REPAIR MANUAL

IDENTIFICATION 1 - SECTION 46 - BULKHEAD STRUCTURE



Section 46 Bulkhead Structure Identification
Figure 1

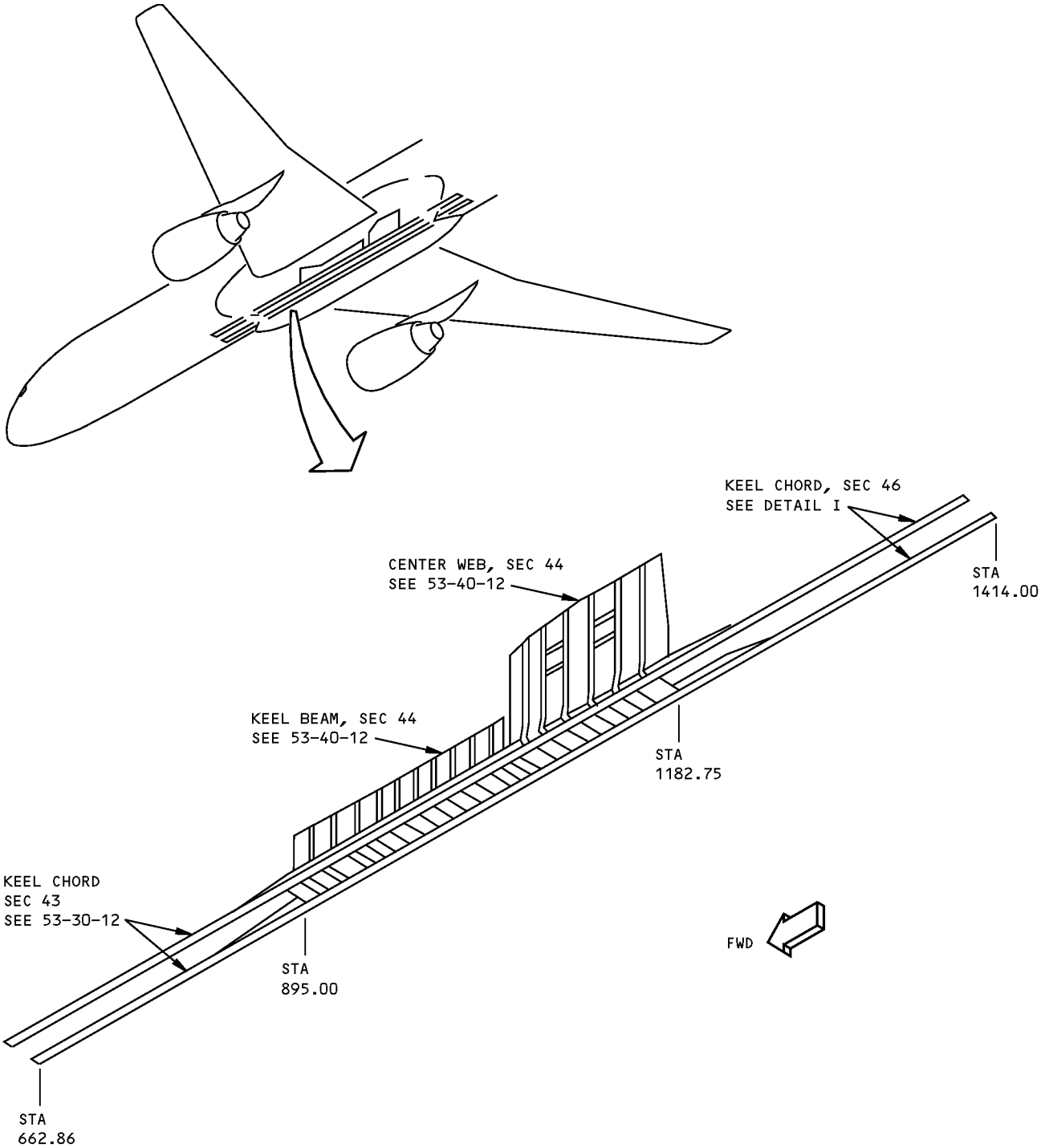
D634N201

53-60-08

IDENTIFICATION 1
Page 1
Jan 20/2005

**757-200
STRUCTURAL REPAIR MANUAL**

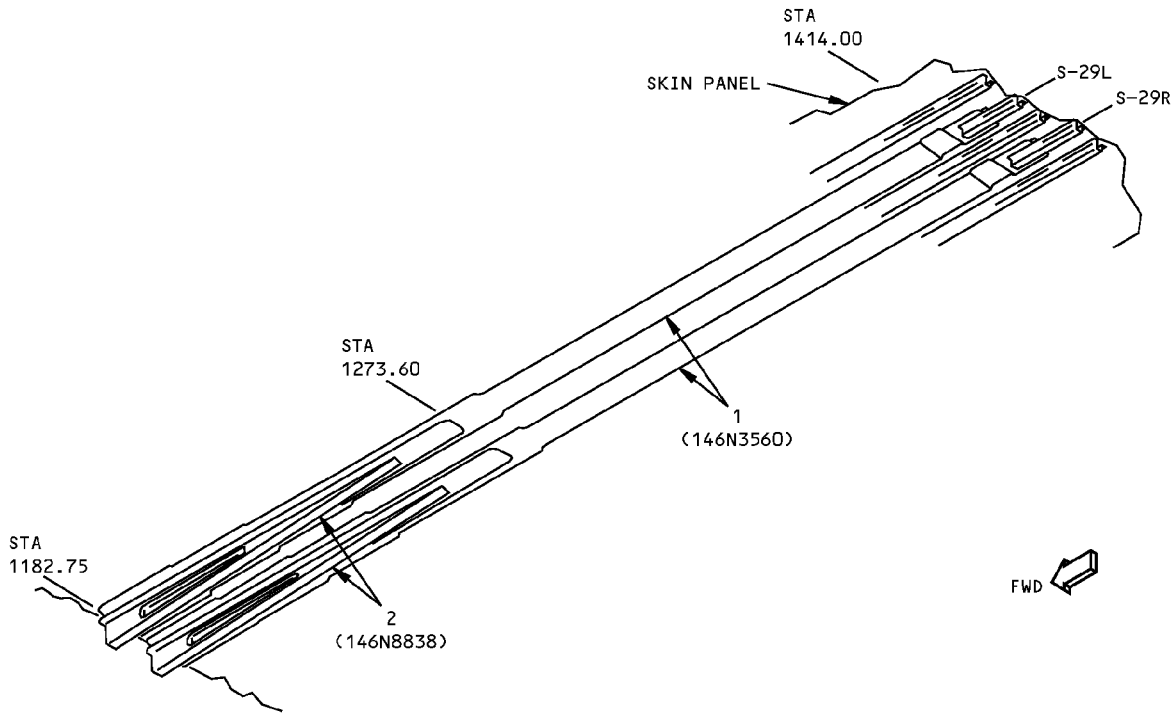
IDENTIFICATION 1 - SECTION 46 - KEEL BEAM STRUCTURE



**Section 46 - Keel Beam Structure Identification
Figure 1 (Sheet 1 of 2)**

**757-200
STRUCTURAL REPAIR MANUAL**

REF DWG
146N3300



DETAIL I

ITEM	DESCRIPTION	GAGE	MATERIAL	EFFECTIVITY
1	KEEL CHORD		BAC1506-3265 7075-T73511 OR BAC1506-3589 7075-T73511	
2	KEEL CHORD EXTENSION		BAC1506-3217 7075-T73511	

LIST OF MATERIALS FOR DETAIL I

**Section 46 - Keel Beam Structure Identification
Figure 1 (Sheet 2 of 2)**

IDENTIFICATION 1
Page 2
Jan 20/2005

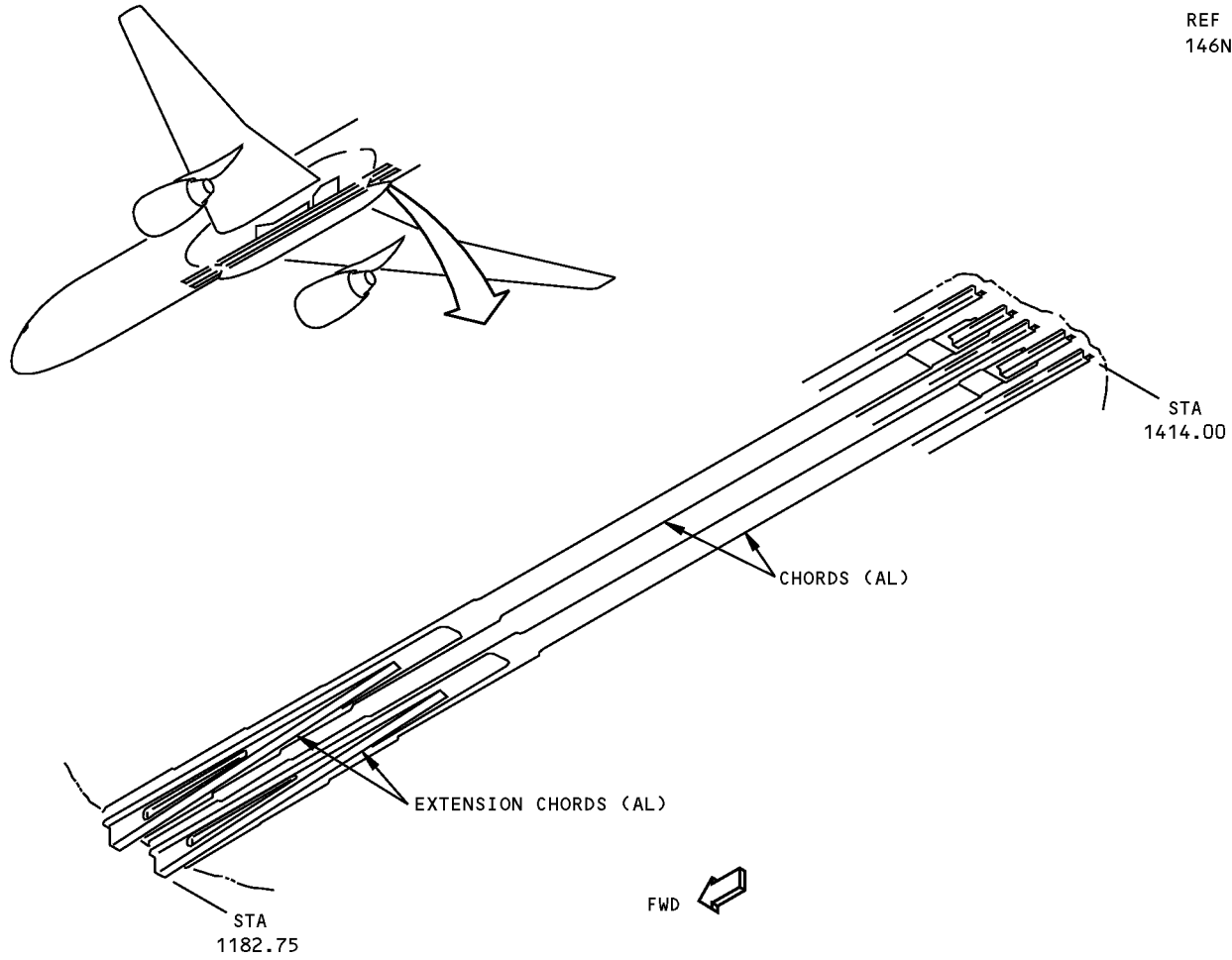
53-60-12

D634N201

**757-200
STRUCTURAL REPAIR MANUAL**

ALLOWABLE DAMAGE 1 - SECTION 46 - KEEL BEAM STRUCTURE

REF DWG
146N3300



DESCRIPTION	CRACKS	NICKS, GOUGES AND CORROSION	DENTS	HOLES AND PUNCTURES
CHORDS	A	B	NOT ALLOWED	NOT ALLOWED

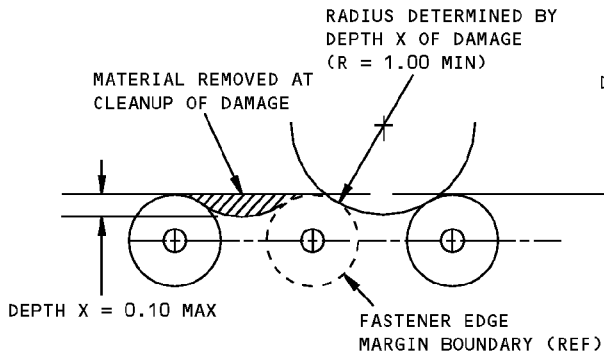
NOTES

- REFINISH REWORKED AREAS PER 51-20 OF THE MAINTENANCE MANUAL
- A** CRACKS NOT ALLOWED. EDGE CRACKS MUST BE REMOVED PER DETAILS I AND III. ELSEWHERE THE AFFECTED PART MUST BE REPLACED OR REPAIRED

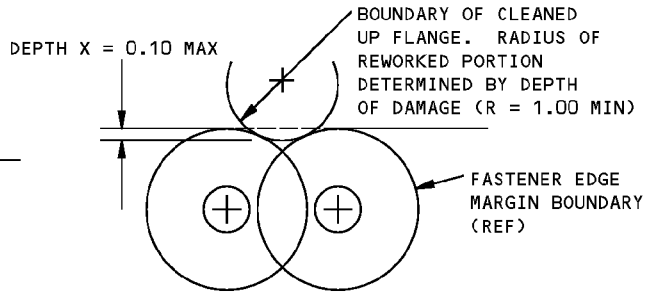
- B** REMOVE DAMAGE PER DETAILS I, II, III AND IV. THE TOTAL CROSS-SECTIONAL AREA REMOVED MUST NOT EXCEED 10% OF THE ORIGINAL CROSS-SECTIONAL AREA OF THE FLANGE

**Section 46 - Keel Beam Structure Allowable Damage
Figure 101 (Sheet 1 of 2)**

STRUCTURAL REPAIR MANUAL

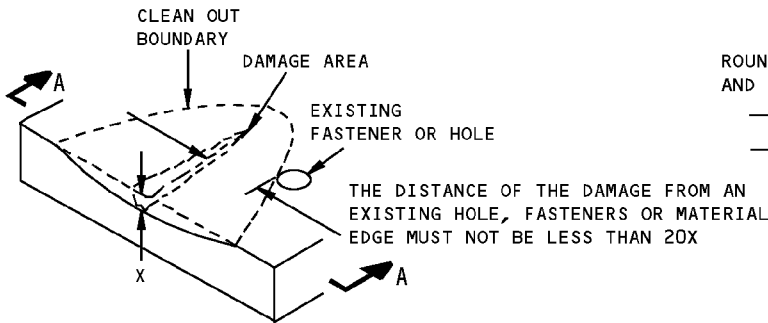


DAMAGE CLEANUP OF EDGES WHERE FASTENER EDGE MARGINS DO NOT OVERLAP

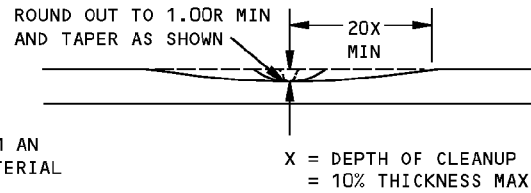


DAMAGE CLEANUP OF EDGES WHERE FASTENER EDGE MARGINS OVERLAP

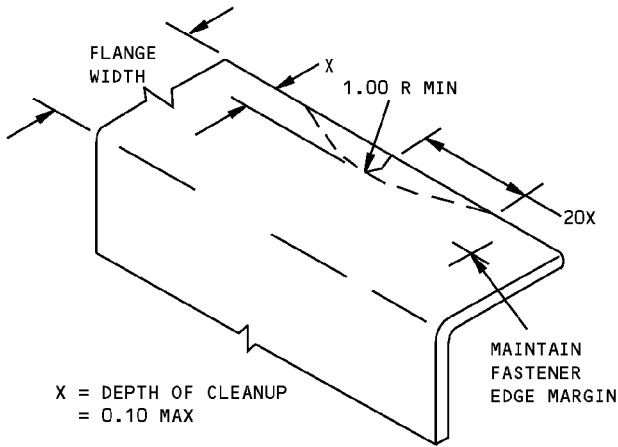
DETAIL I



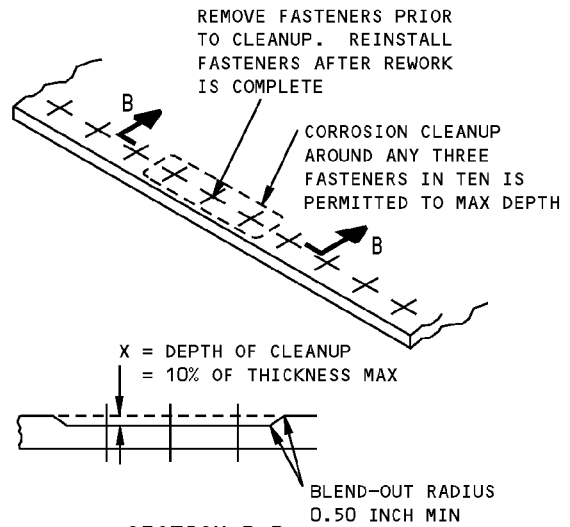
REMOVAL OF NICK, GOUGE AND SCRATCH DAMAGE ON A SURFACE
DETAIL II



SECTION A-A



REMOVAL OF NICK OR CRACK DAMAGE ON AN EDGE
DETAIL III



SECTION B-B

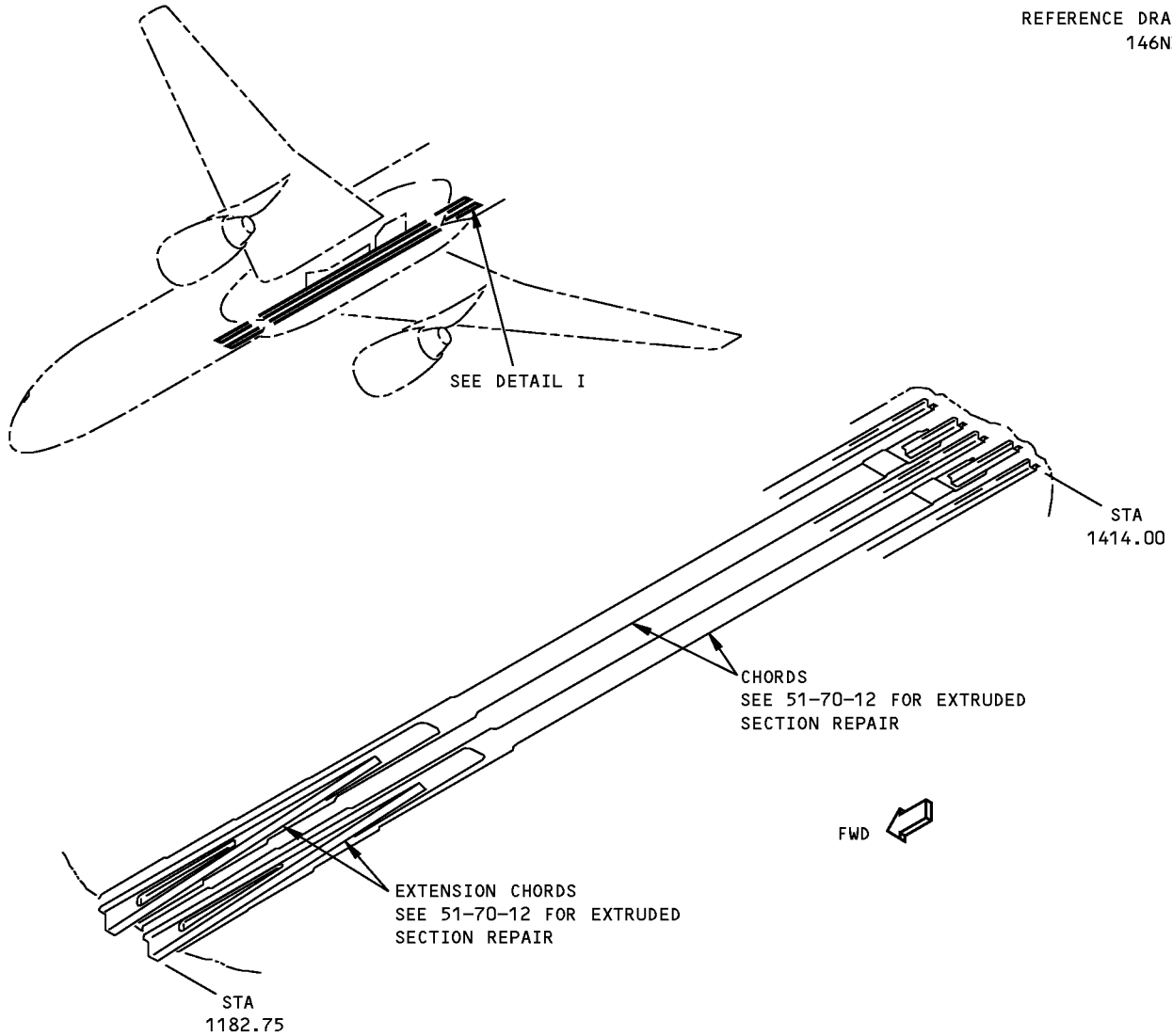
CORROSION CLEANUP
DETAIL IV

**Section 46 - Keel Beam Structure Allowable Damage
Figure 101 (Sheet 2 of 2)**

**757-200
STRUCTURAL REPAIR MANUAL**

REPAIR GENERAL - SECTION 46 - KEEL CHORD REPAIR

REFERENCE DRAWING
146N3300



DETAIL I

NOTES

- THIS IS A CATEGORY A REPAIR. THE INSPECTIONS GIVEN IN THE MAINTENANCE PLANNING DATA (MPD) ARE SUFFICIENT TO MAINTAIN THE DAMAGE TOLERANCE OF THE INITIAL STRUCTURE WITH THIS REPAIR INSTALLED. REFER TO SRM 51-00-06 FOR REPAIR CATEGORIES AND DEFINITIONS.

L50351 S0006803302_V2

**Section 46 - Keel Chord Repair
Figure 201**

D634N201

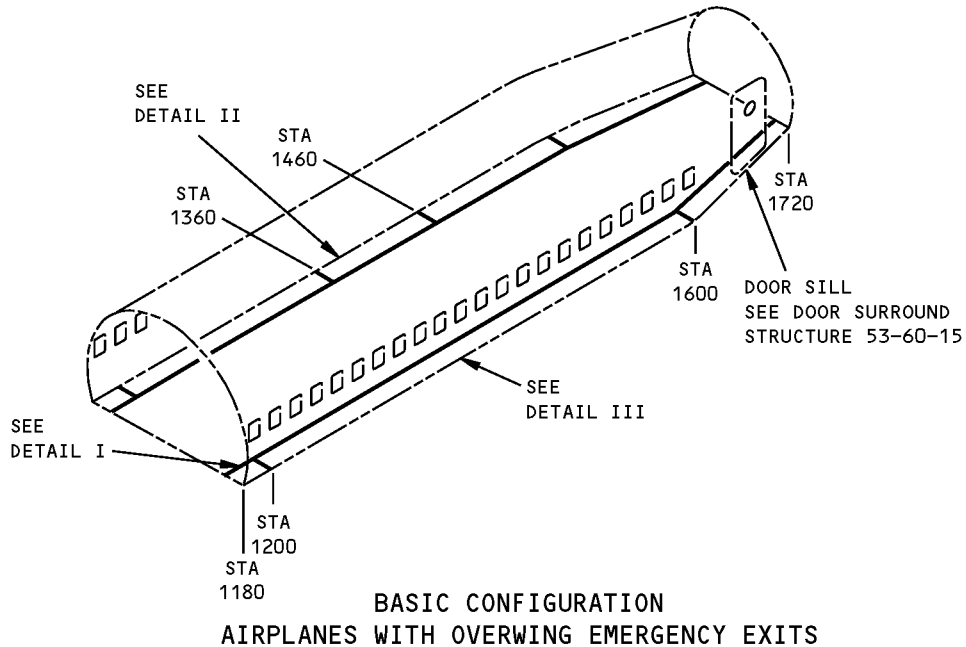
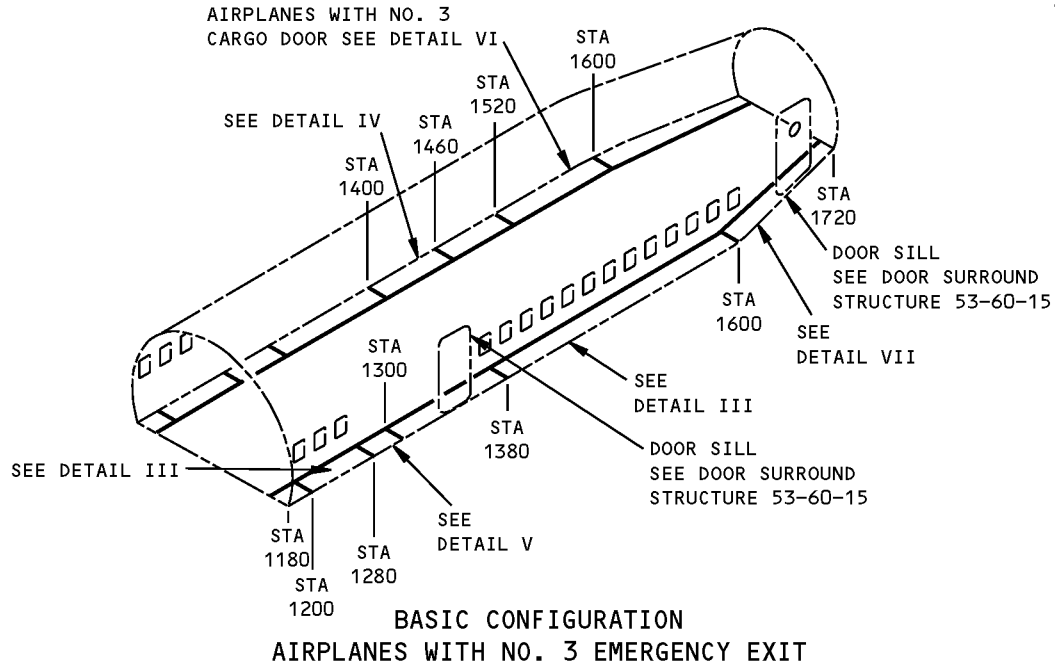
53-60-12

REPAIR GENERAL
Page 201
Sep 20/2008

**757-200
STRUCTURAL REPAIR MANUAL**

IDENTIFICATION 1 - SECTION 46 - CREASE BEAM

REF DWG
146N5590



NOTES

- RIGHT SIDE OPPOSITE LEFT SIDE EXCEPT WHERE NOTED

- A** OPTIONAL MATERIAL UNTIL 2024-T3511 BECOMES AVAILABLE
FOR AIRPLANES WITH NO. 3 CARGO DOOR
- B** FOR 757-SF AIRPLANES ONLY

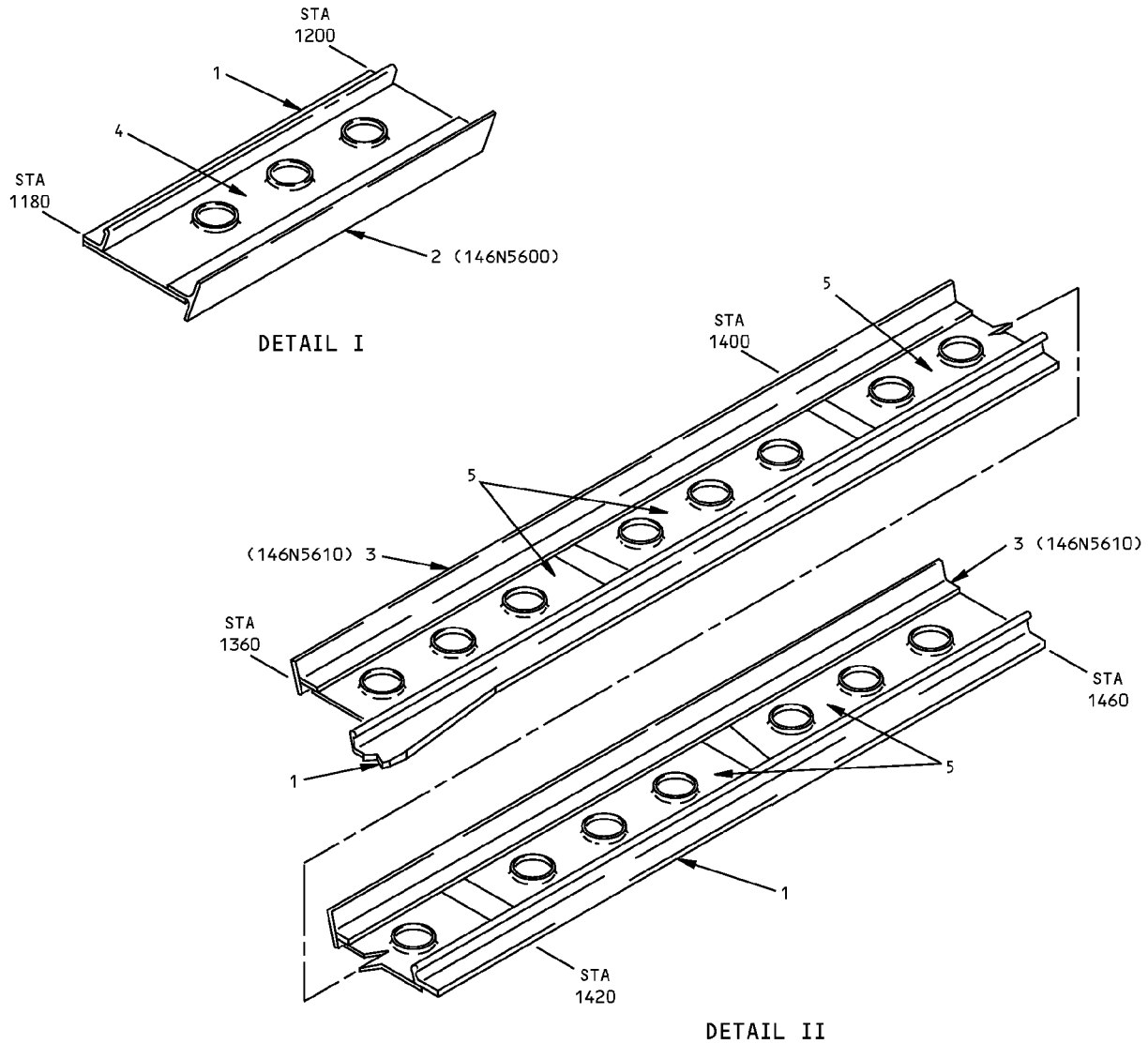
**Section 46 - Crease Beam Identification
Figure 1 (Sheet 1 of 6)**

IDENTIFICATION 1
Page 1
Jan 20/2006

53-60-13

D634N201

**757-200
STRUCTURAL REPAIR MANUAL**



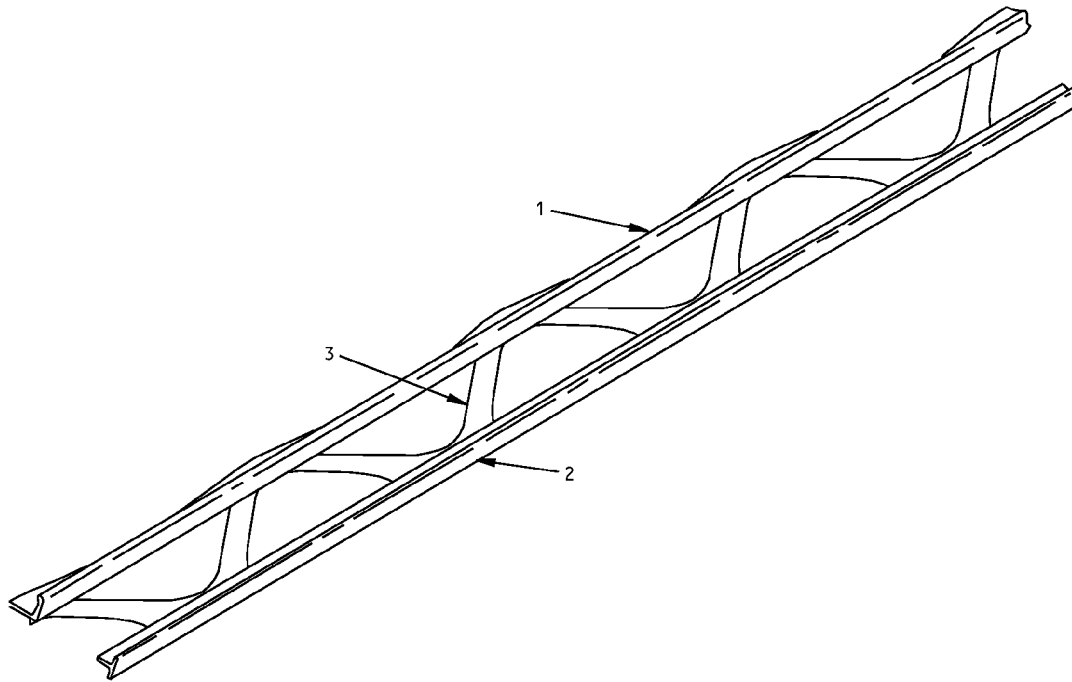
ITEM	DESCRIPTION	GAGE	MATERIAL	EFFECTIVITY
1	CHORD - INBOARD		BAC1515-553 7075-T6511	
2	CHORD - OUTBOARD		BAC1506-1148 2024-T3511 OR BAC1506-1148 7075-T6511	A
3	CHORD - OUTBOARD		BAC1506-1903 2024-T3511	
4	WEB	0.050	7075-T6	
5	WEB	0.040	7075-T6	

LIST OF MATERIALS FOR DETAILS I AND II

**Section 46 - Crease Beam Identification
Figure 1 (Sheet 2 of 6)**

**757-200
STRUCTURAL REPAIR MANUAL**

REF DWG
146N5590



TYPICAL TRUSS CREASE BEAM INSTALLATION
DETAIL III

ITEM	DESCRIPTION	GAGE	MATERIAL	EFFECTIVITY
1	CHORD - INBOARD		BAC1515-553 7075-T6511	
2	CHORD - OUTBOARD		BAC1506-3406 2024-T3511	
3	TRUSS	0.080	CLAD 7075-T6	

LIST OF MATERIALS FOR DETAIL III

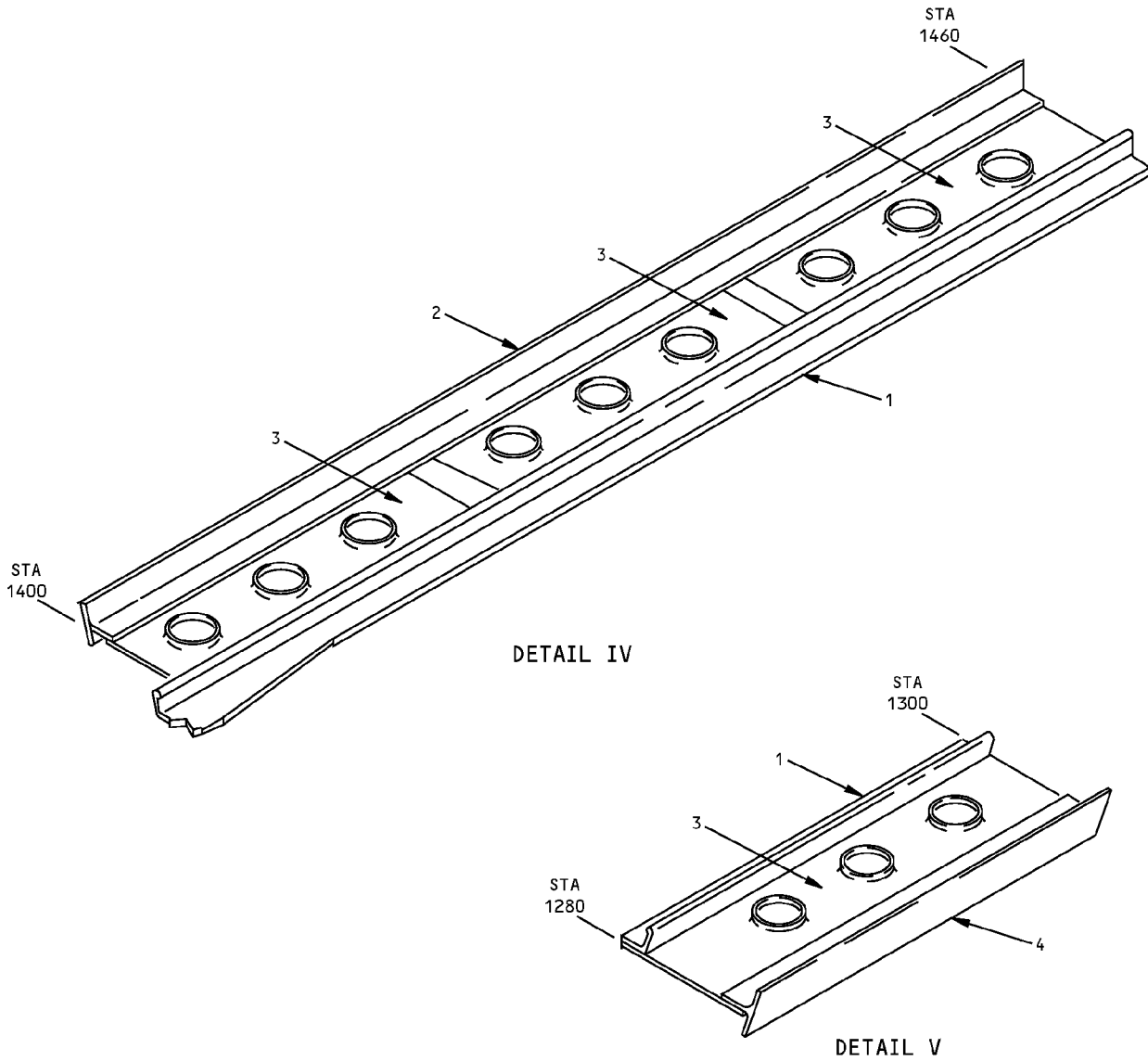
**Section 46 - Crease Beam Identification
Figure 1 (Sheet 3 of 6)**

IDENTIFICATION 1
Page 3
Jan 20/2006

53-60-13

D634N201

**757-200
STRUCTURAL REPAIR MANUAL**

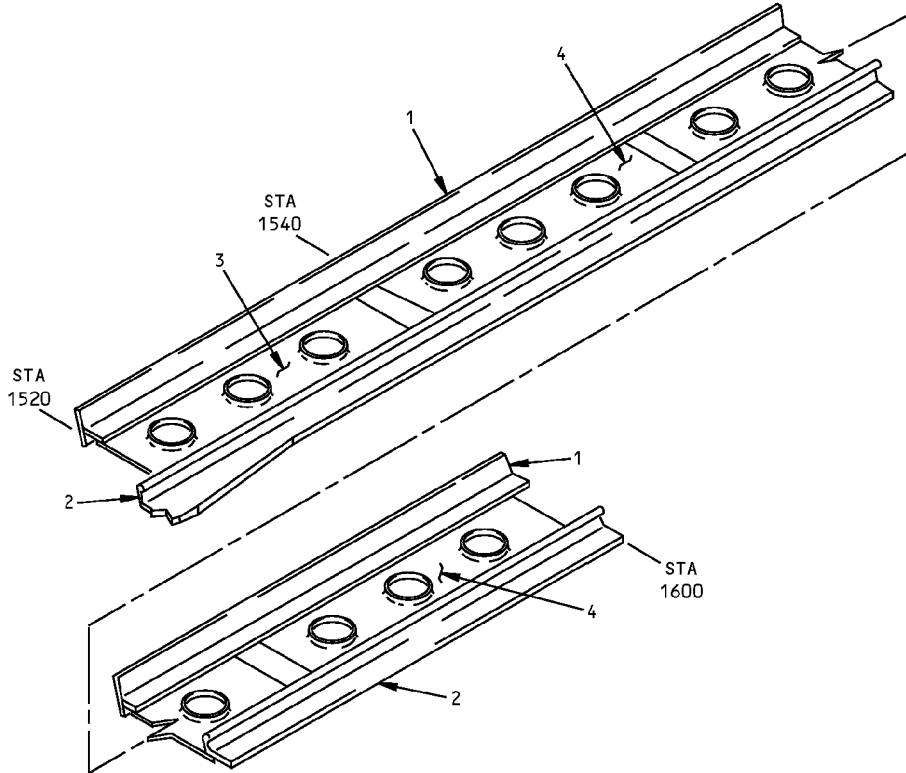


ITEM	DESCRIPTION	GAGE	MATERIAL	EFFECTIVITY
1	CHORD - INBOARD		BAC1515-553 7075-T6511	
2	CHORD - OUTBOARD		BAC1506-1903 2024-T3511	
3	WEB	0.040	7075-T6	
4	CHORD - OUTBOARD		BAC1506-3406 2024-T3511	

LIST OF MATERIALS FOR DETAILS IV AND V

**Section 46 - Crease Beam Identification
Figure 1 (Sheet 4 of 6)**

**757-200
STRUCTURAL REPAIR MANUAL**



DETAIL VI

ITEM	DESCRIPTION	GAGE	MATERIAL	EFFECTIVITY
1	OUTER CHORD		BAC1506-3406 2024-T3511 OR BAC1506-1941 7075-T6511	B
2	INNER CHORD		BAC1515-553 7075-T6511	
3	WEB	0.050	CLAD 7075-T6	
4	WEB	0.040	CLAD 7075-T6	

LIST OF MATERIALS FOR DETAIL VI

**Section 46 - Crease Beam Identification
Figure 1 (Sheet 5 of 6)**

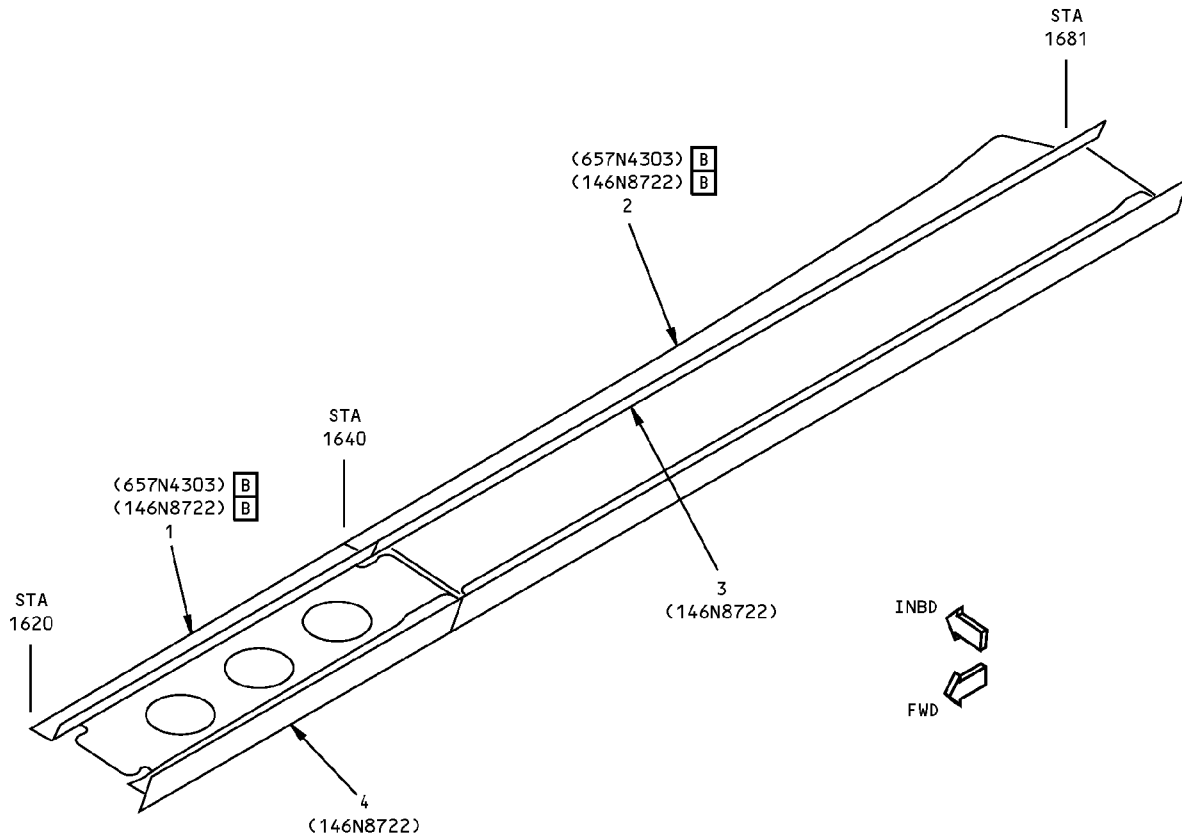
IDENTIFICATION 1
Page 5
Jan 20/2006

53-60-13

D634N201

**757-200
STRUCTURAL REPAIR MANUAL**

Ref Dwg
146N8722
657N4303



**DETAIL VII
LEFT AND RIGHT HAND**

ITEM	DESCRIPTION	GAGE	MATERIAL	EFFECTIVITY
1	WEB	0.056	7075-T62 CLAD	
2	WEB	0.071	7075-T62 CLAD	
3	INNER CHORD	0.090	15.5 PH CRES HT TR 180-200 KSI	
4	OUTER CHORD		BAC1506-2002 7075-T73	

LIST OF MATERIALS FOR DETAIL VII

**Section 46 - Crease Beam Identification
Figure 1 (Sheet 6 of 6)**

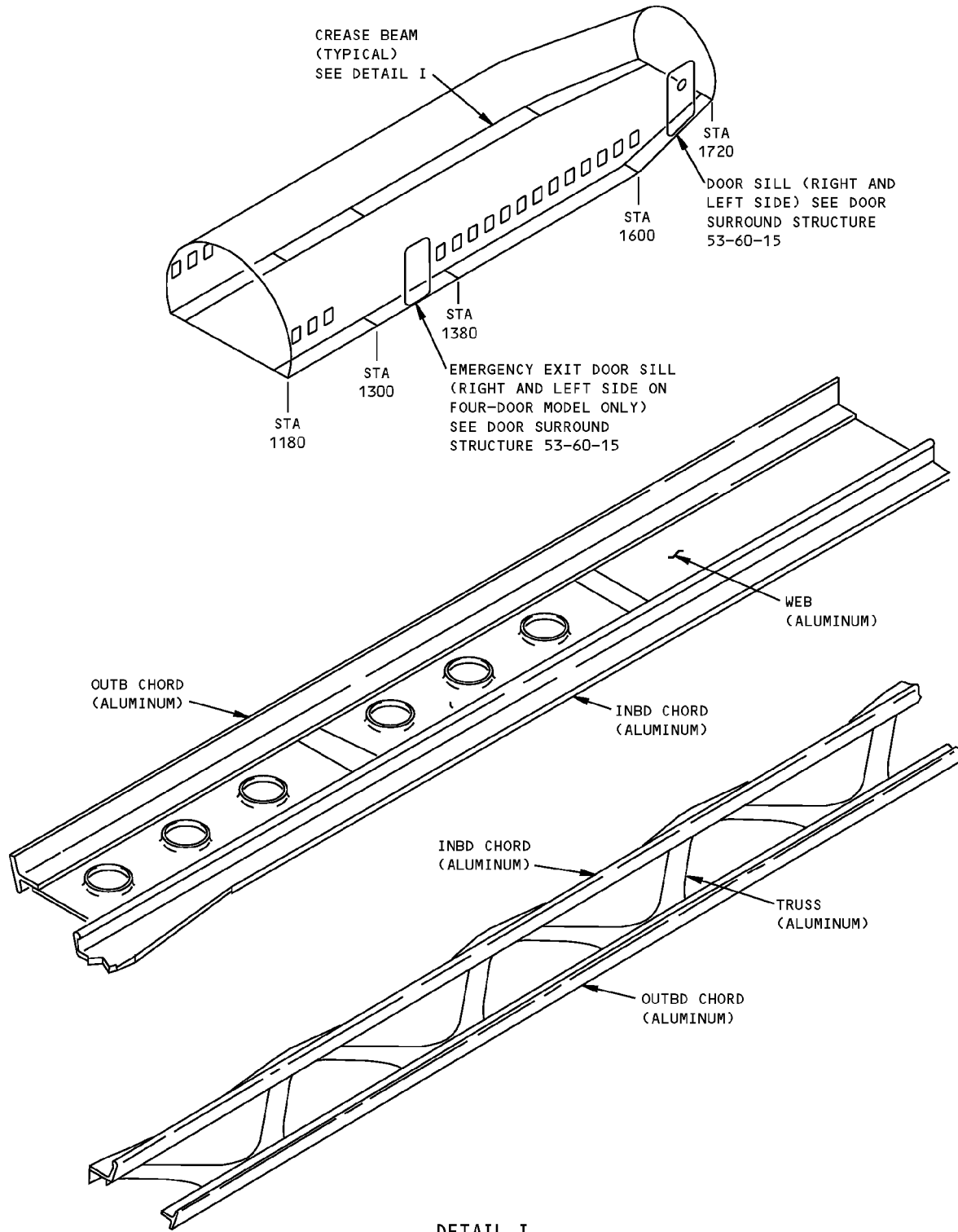
IDENTIFICATION 1
Page 6
Jan 20/2006

53-60-13

D634N201

**757-200
STRUCTURAL REPAIR MANUAL**

ALLOWABLE DAMAGE 1 - SECTION 46 - CREASE BEAM



DETAIL I

**Section 46 Crease Beam Allowable Damage
Figure 101 (Sheet 1 of 5)**

**757-200
STRUCTURAL REPAIR MANUAL**

DESCRIPTION	CRACKS	NICKS, GOUGES AND CORROSION	DENTS	HOLES AND PUNCTURES
WEBS - SOLID	[B]	[A]	SEE DETAIL IV	[D]
WEBS - FLANGED HOLE	[B]	[C]	SEE DETAIL IV	[D]
CHORD - INBD	[G]	SEE DETAIL VIII	NOT PERMITTED	NOT PERMITTED
CHORD - OUTBD	[H]	[F]	NOT PERMITTED	NOT PERMITTED
TRUSS	[E]	[J]	NOT PERMITTED	[K]

NOTES

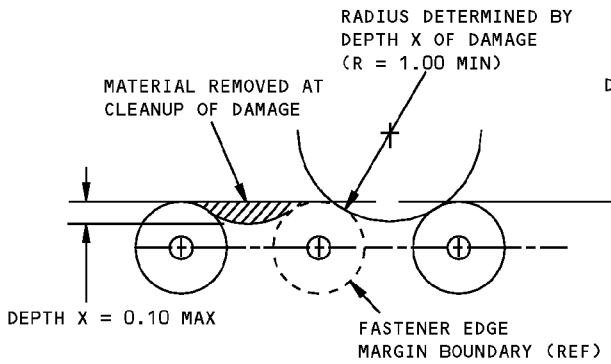
- THIS ALLOWABLE DAMAGE DATA IS APPLICABLE TO PASSENGER AIRPLANES ONLY.
- REFER TO IDENTIFICATION 1 FOR CREASE BEAM LOCATIONS
- REFINISH REWORKED AREAS AS SHOWN IN AMM 51-20
- REFER TO 51-10-02 FOR INSPECTION AND REMOVAL OF DAMAGE

- [A] REMOVE DAMAGE AS SHOWN IN DETAILS II, III, AND V
- [B] FOR EDGE CRACKS SEE DETAILS II AND V. FOR LIGHTENING HOLE EDGE CRACKS SEE DETAIL VI
- [C] REMOVE DAMAGE AS SHOWN IN DETAILS III, V, AND VI
- [D] CLEAN OUT DAMAGE UP TO 0.25 INCH (6 mm) MAX DIA AND NOT CLOSER THAN 1.5 INCHES (38 mm) TO FASTENER HOLE, MATERIAL EDGE, OR OTHER DAMAGE. FILL HOLE WITH 2117-T3 OR T4 ALUMINUM RIVET INSTALLED WET WITH BMS 5-95 SEALANT. ALL OTHER HOLES TO BE REPAIRED
- [E] CRACKS ARE NOT PERMITTED EXCEPT FOR EDGE CRACKS WHICH MAY BE REMOVED AS SHOWN IN DETAILS II AND V

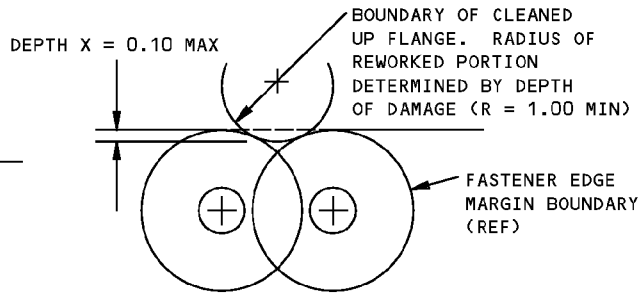
- [F] REMOVE DAMAGE AS SHOWN IN DETAILS II AND III
- [G] CRACKS ARE NOT PERMITTED EXCEPT FOR EDGE CRACKS WHICH MUST BE REMOVED AS SHOWN IN DETAILS II AND VIII
- [H] CRACKS ARE NOT PERMITTED EXCEPT FOR EDGE CRACKS WHICH MUST BE REMOVED AS SHOWN IN DETAILS II AND III
- [J] REMOVE EDGE DAMAGE AS SHOWN IN DETAILS II AND V. BLEND OUT SURFACE DAMAGE PER DETAIL VII
- [K] CLEAN OUT DAMAGE TO WEB PORTION OF TRUSS ONLY UP TO 0.25 INCH (6 mm) DIA AND NOT CLOSER THAN 1.0 INCH (25 mm) TO FASTENER HOLE, MATERIAL EDGE, OR OTHER DAMAGE. FILL HOLE WITH 2117-T3 OR T4 ALUMINUM RIVET INSTALLED WET WITH BMS 5-95 SEALANT. ALL OTHER HOLES TO BE REPAIRED

**Section 46 Crease Beam Allowable Damage
Figure 101 (Sheet 2 of 5)**

**757-200
STRUCTURAL REPAIR MANUAL**

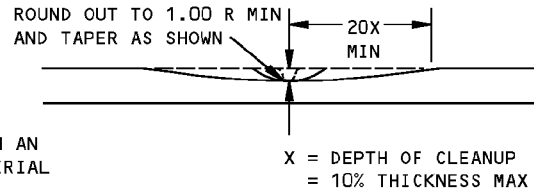
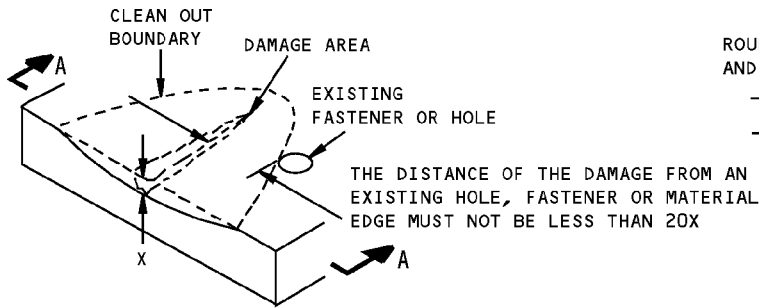


DAMAGE CLEANUP OF EDGES WHERE FASTENER EDGE MARGINS DO NOT OVERLAP



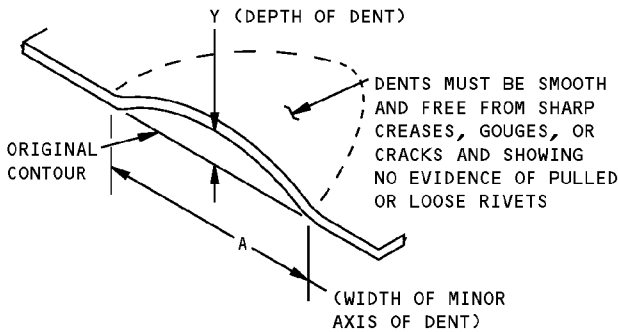
DAMAGE CLEANUP OF EDGES WHERE FASTENER EDGE MARGINS OVERLAP

DETAIL II



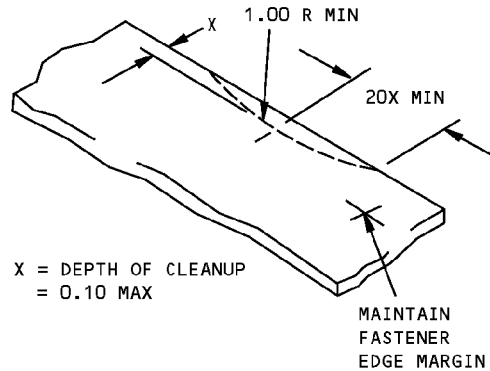
SECTION A-A

**REMOVAL OF NICK, GOUGE AND SCRATCH DAMAGE ON A SURFACE
DETAIL III**



$\frac{A}{Y}$ MUST NOT BE LESS THAN 30
Y (MAX) = 0.125

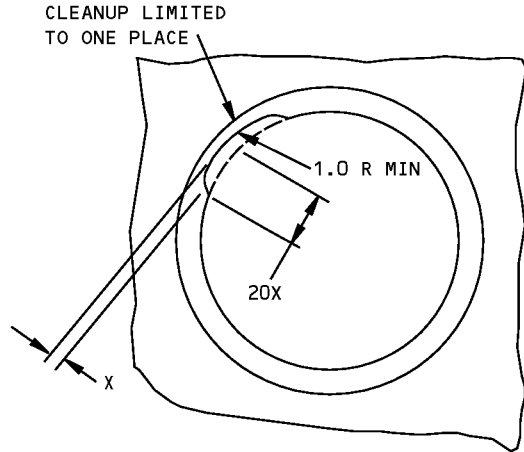
**ALLOWABLE DAMAGE FOR DENT
DETAIL IV**



**REMOVAL OF NICK OR CRACK
DAMAGE ON AN EDGE
DETAIL V**

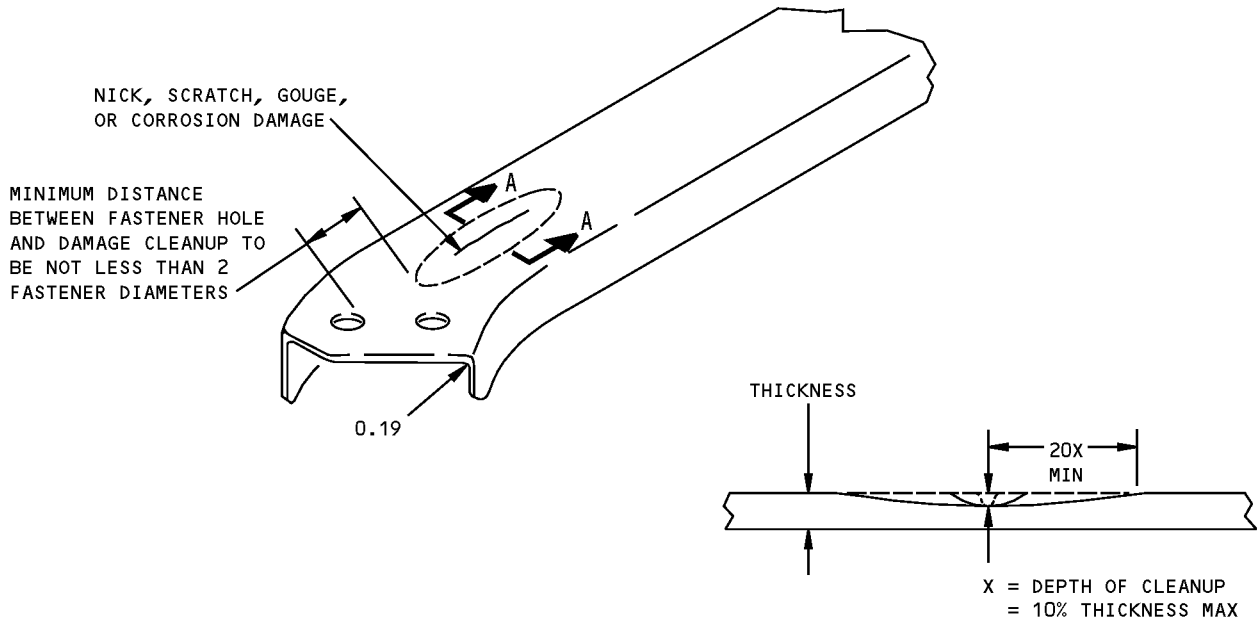
**Section 46 Crease Beam Allowable Damage
Figure 101 (Sheet 3 of 5)**

STRUCTURAL REPAIR MANUAL



X = DEPTH OF CLEANUP = 0.10 MAX OR
1/2 FLANGE WIDTH WHICHEVER IS LESS

**FLANGED HOLE EDGE DAMAGE CLEANUP
DETAIL VI**

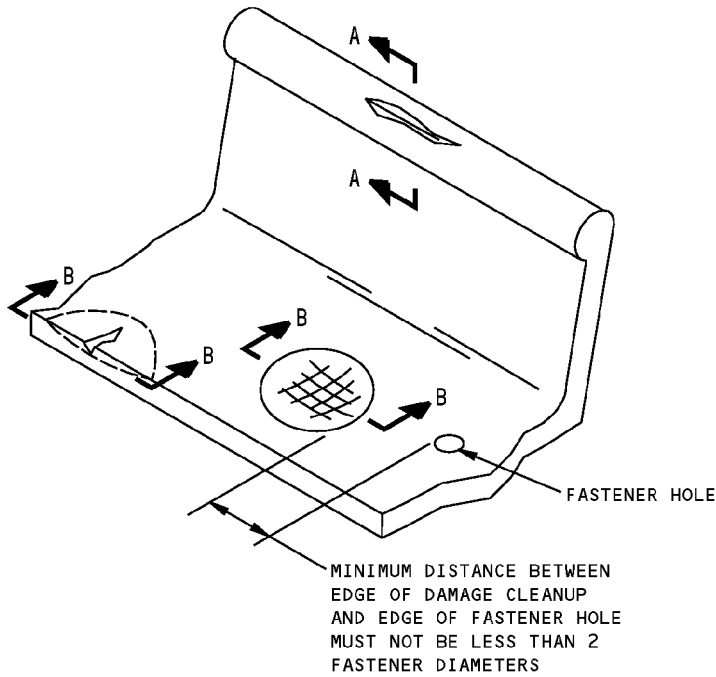


SECTION A-A

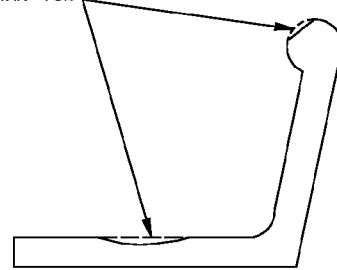
**NICK, GOUGE, AND SCRATCH REMOVAL
FROM SURFACE OF CREASE BEAM TRUSS
DETAIL VII**

**Section 46 Crease Beam Allowable Damage
Figure 101 (Sheet 4 of 5)**

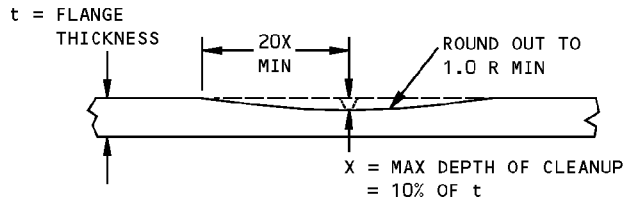
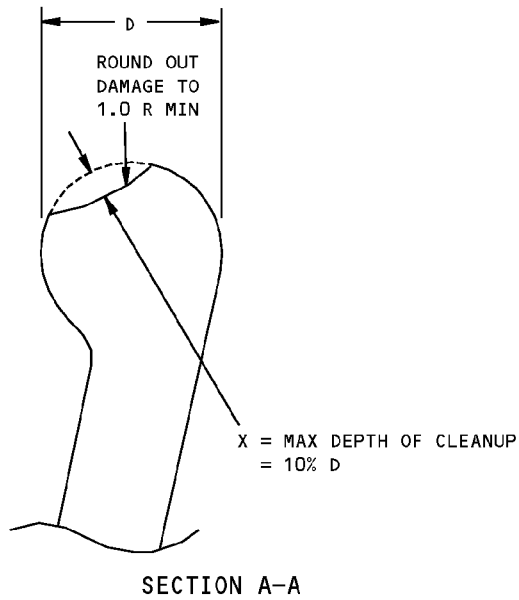
**757-200
STRUCTURAL REPAIR MANUAL**



DAMAGE CLEANUP MUST NOT
REDUCE CROSS-SECTIONAL
AREA BY MORE THAN 10%



SECTION THRU EXTRUSION



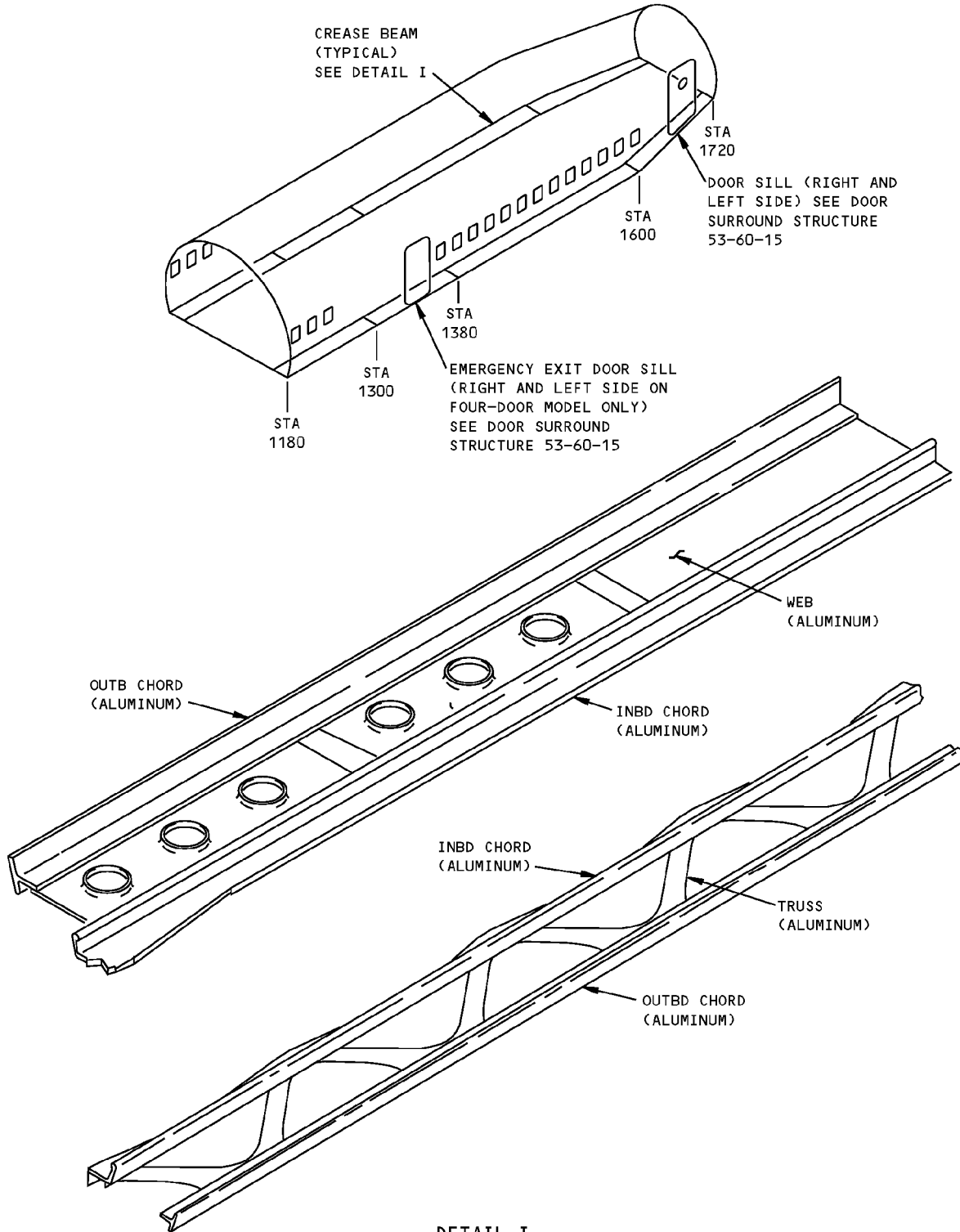
SECTION B-B

**DAMAGE CLEANUP OF BULB ANGLE
DETAIL VIII**

**Section 46 Crease Beam Allowable Damage
Figure 101 (Sheet 5 of 5)**

**757-200
STRUCTURAL REPAIR MANUAL**

ALLOWABLE DAMAGE 2 - SECTION 46 - CREASE BEAM - 757-SF



DETAIL I

**Section 46 Crease Beam Allowable Damage - 757-SF
Figure 101 (Sheet 1 of 5)**

**757-200
STRUCTURAL REPAIR MANUAL**

DESCRIPTION	CRACKS	NICKS, GOUGES AND CORROSION	DENTS	HOLES AND PUNCTURES
WEBS - SOLID	B	A L	SEE DETAIL IV	D
WEBS - FLANGED HOLE	B	C M	SEE DETAIL IV	D
CHORD - INBOARD	G	SEE DETAIL VIII	NOT PERMITTED	NOT PERMITTED
CHORD - OUTBOARD	H	F	NOT PERMITTED	NOT PERMITTED
TRUSS	E	J	NOT PERMITTED	K

NOTES

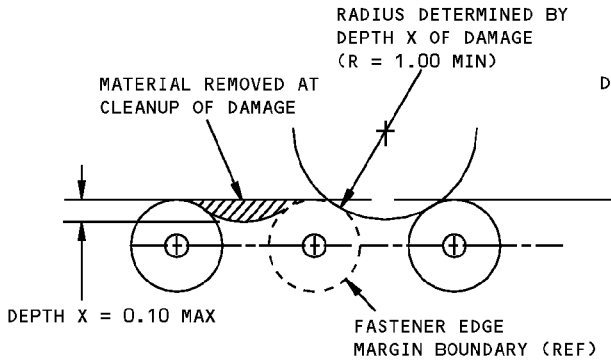
- THIS ALLOWABLE DAMAGE DATA IS APPLICABLE TO 757-SF AIRPLANES ONLY
- THIS ALLOWABLE DAMAGE IS A CATEGORY A REPAIR FOR 757-SF AIRPLANES. THE INSPECTIONS GIVEN IN THE MAINTENANCE PLANNING DATA (MPD) AND ASSOCIATED SUPPLEMENT ARE SUFFICIENT TO MAINTAIN THE DAMAGE TOLERANCE OF THE INITIAL STRUCTURE WITH THIS ALLOWABLE DAMAGE. REFER TO SRM 51-00-06 FOR REPAIR CATEGORIES AND DEFINITIONS.
- REFER TO IDENTIFICATION 1 FOR CREASE BEAM LOCATIONS
- ALL DIMENSIONS ARE IN INCHES
- REFINISH REWORKED AREAS IN AS GIVEN IN AMM 51-21
- REFER TO SRM 51-10-02 FOR INSPECTION AND REMOVAL OF DAMAGE

- A** REMOVE DAMAGE AS SHOWN IN DETAILS II, III, AND V.
- B** FOR EDGE CRACKS SEE DETAILS II AND V. FOR LIGHTENING HOLE EDGE CRACKS SEE DETAIL VI.
- C** REMOVE DAMAGE AS SHOWN IN DETAILS III, V, AND VI.
- D** CLEAN OUT DAMAGE UP TO 0.25 INCH (6 mm) MAX DIA AND NOT CLOSER THAN 1.5 INCHES (38 mm) TO FASTENER HOLE, MATERIAL EDGE, OR OTHER DAMAGE. FILL HOLE WITH 2117-T3 OR T4 ALUMINUM RIVET INSTALLED WET WITH BMS 5-95 SEALANT. ALL OTHER HOLES TO BE REPAIRED.
- E** CRACKS ARE NOT PERMITTED EXCEPT FOR EDGE CRACKS WHICH CAN BE REMOVED AS SHOWN IN DETAILS II AND V.

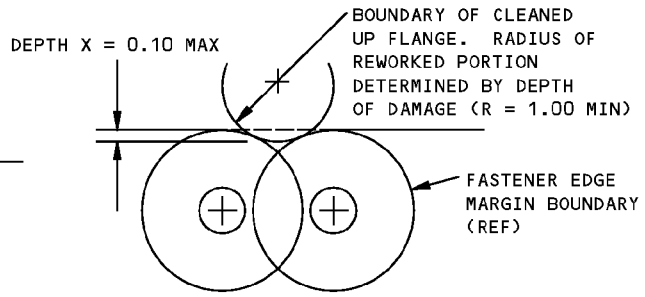
- F** REMOVE DAMAGE AS SHOWN IN DETAILS II AND III.
- G** CRACKS ARE NOT PERMITTED EXCEPT FOR EDGE CRACKS WHICH MUST BE REMOVED AS SHOWN IN DETAILS II AND VIII.
- H** CRACKS ARE NOT PERMITTED EXCEPT FOR EDGE CRACKS WHICH MUST BE REMOVED AS SHOWN IN DETAILS II AND III.
- J** REMOVE EDGE DAMAGE AS SHOWN IN DETAILS II AND V. BLEND OUT SURFACE DAMAGE AS SHOWN IN DETAIL VII.
- K** CLEAN OUT DAMAGE TO WEB PORTION OF TRUSS ONLY UP TO 0.25 INCH (6 mm) DIA AND NOT CLOSER THAN 1.0 INCH (25 mm) TO FASTENER HOLE, MATERIAL EDGE, OR OTHER DAMAGE. FILL HOLE WITH 2117-T3 OR T4 ALUMINUM RIVET INSTALLED WET WITH BMS 5-95 SEALANT. ALL OTHER HOLES TO BE REPAIRED.
- L** DAMAGE REMOVAL AS SHOWN IN DETAIL III NOT PERMITTED BETWEEN STA. 1320 AND STA. 1350.
- M** DAMAGE REMOVAL AS SHOWN IN DETAIL III NOT PERMITTED BETWEEN:
- STA. 1180 AND STA. 1200
 - STA. 1400 AND STA. 1460 (RIGHT HAND SIDE ONLY)
 - STA. 1600 AND STA. 1640.

**Section 46 Crease Beam Allowable Damage - 757-SF
Figure 101 (Sheet 2 of 5)**

STRUCTURAL REPAIR MANUAL

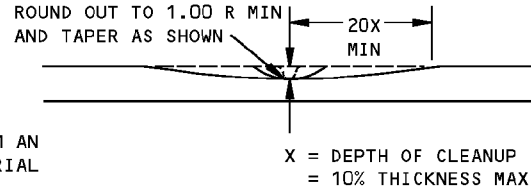
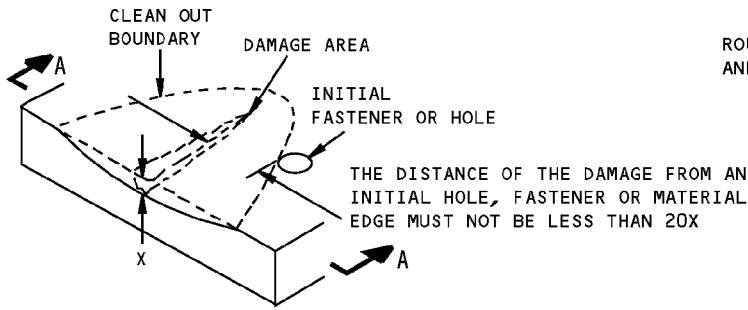


DAMAGE CLEANUP OF EDGES WHERE FASTENER EDGE MARGINS DO NOT OVERLAP



DAMAGE CLEANUP OF EDGES WHERE FASTENER EDGE MARGINS OVERLAP

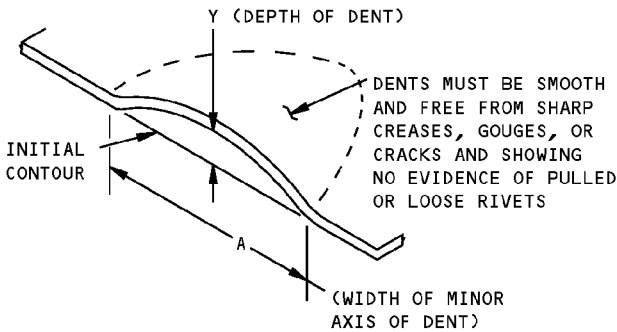
DETAIL II



SECTION A-A

REMOVAL OF NICK, GOUGE AND SCRATCH DAMAGE ON A SURFACE

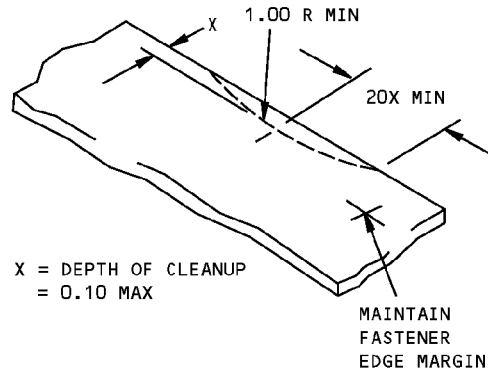
DETAIL III L M



$\frac{A}{Y}$ MUST NOT BE LESS THAN 30

Y (MAX) = 0.125

ALLOWABLE DAMAGE FOR DENT
DETAIL IV



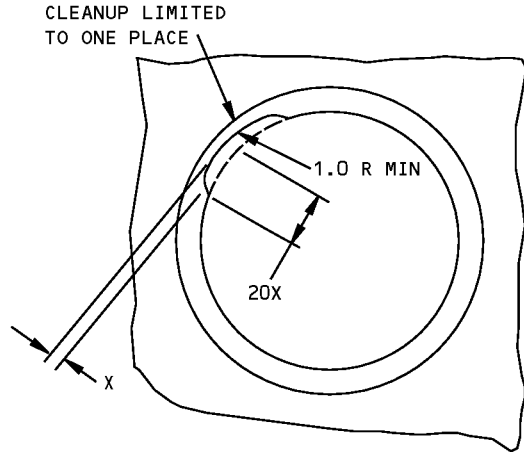
X = DEPTH OF CLEANUP = 0.10 MAX

REMOVAL OF NICK OR CRACK DAMAGE ON AN EDGE

DETAIL V

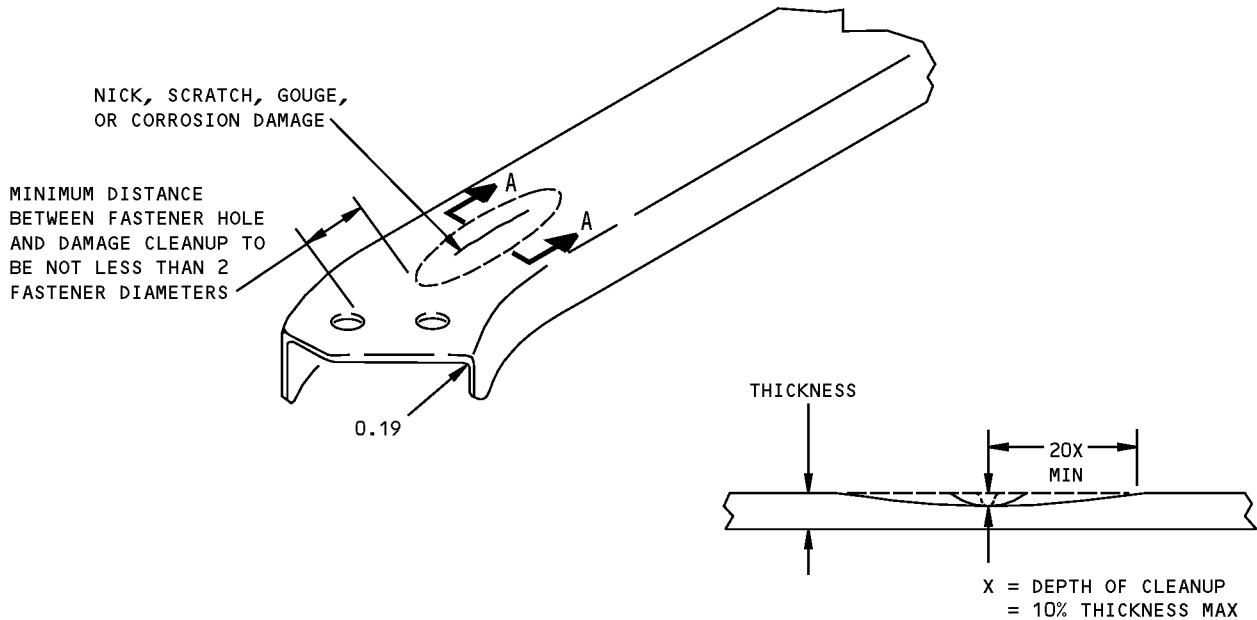
Section 46 Crease Beam Allowable Damage - 757-SF
Figure 101 (Sheet 3 of 5)

STRUCTURAL REPAIR MANUAL



X = DEPTH OF CLEANUP = 0.10 MAX OR
1/2 FLANGE WIDTH WHICHEVER IS LESS

**FLANGED HOLE EDGE DAMAGE CLEANUP
DETAIL VI**

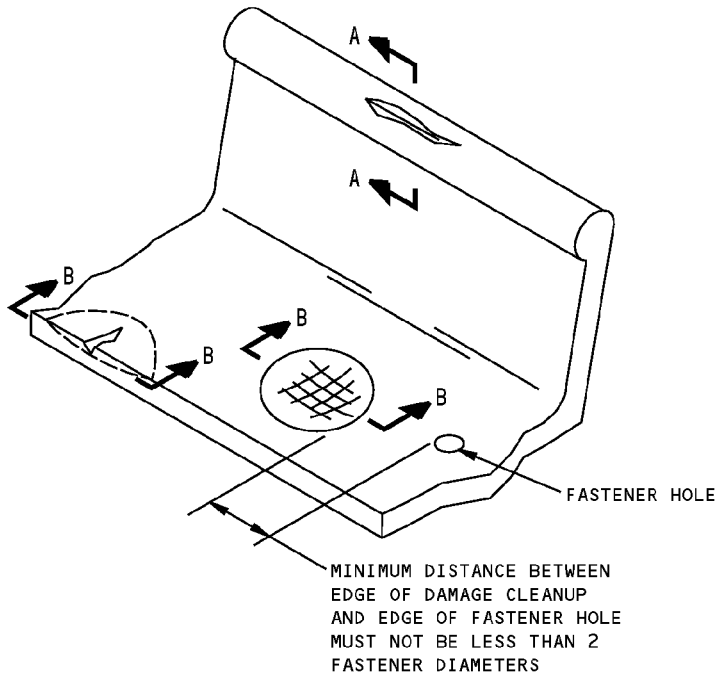


SECTION A-A

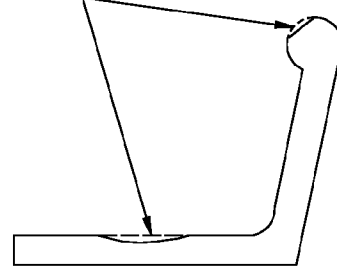
**NICK, GOUGE, AND SCRATCH REMOVAL
FROM SURFACE OF CREASE BEAM TRUSS
DETAIL VII**

**Section 46 Crease Beam Allowable Damage - 757-SF
Figure 101 (Sheet 4 of 5)**

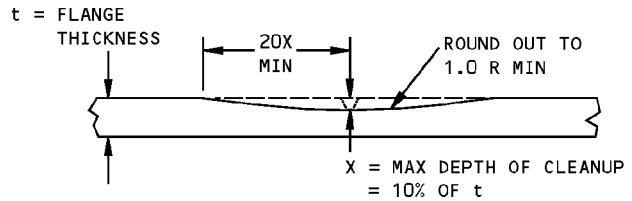
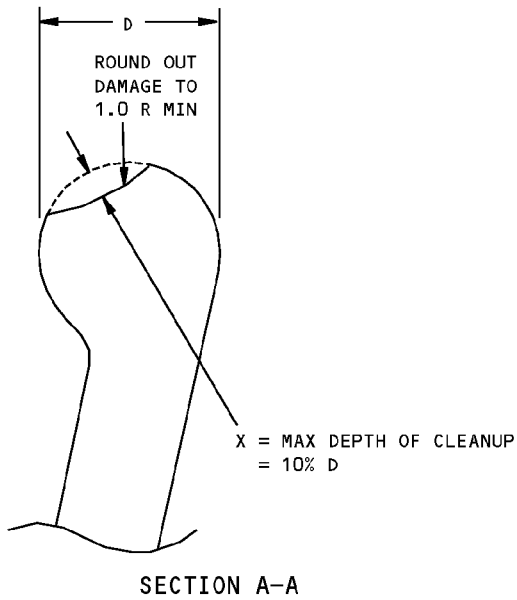
**757-200
STRUCTURAL REPAIR MANUAL**



DAMAGE CLEANUP MUST NOT
REDUCE CROSS-SECTIONAL
AREA BY MORE THAN 10%



SECTION THRU EXTRUSION



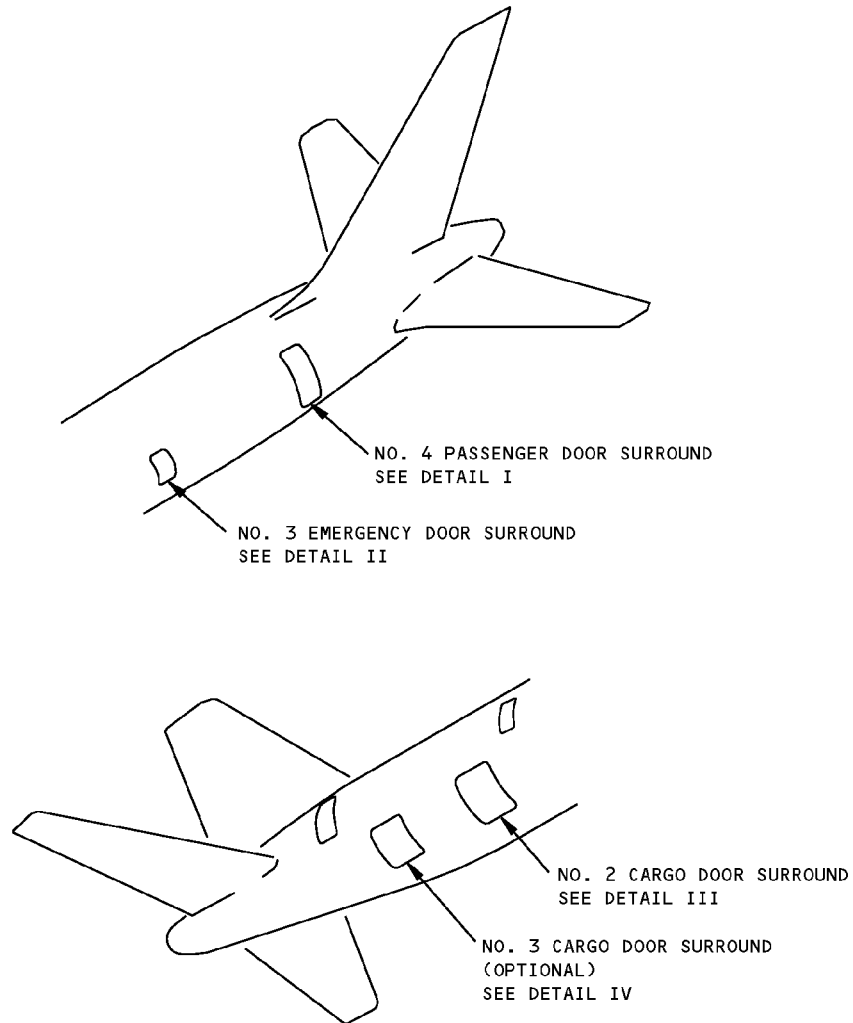
SECTION B-B

**DAMAGE CLEANUP OF BULB ANGLE
DETAIL VIII**

**Section 46 Crease Beam Allowable Damage - 757-SF
Figure 101 (Sheet 5 of 5)**

**757-200
STRUCTURAL REPAIR MANUAL**

IDENTIFICATION 1 - SECTION 46 - DOOR SURROUND STRUCTURE

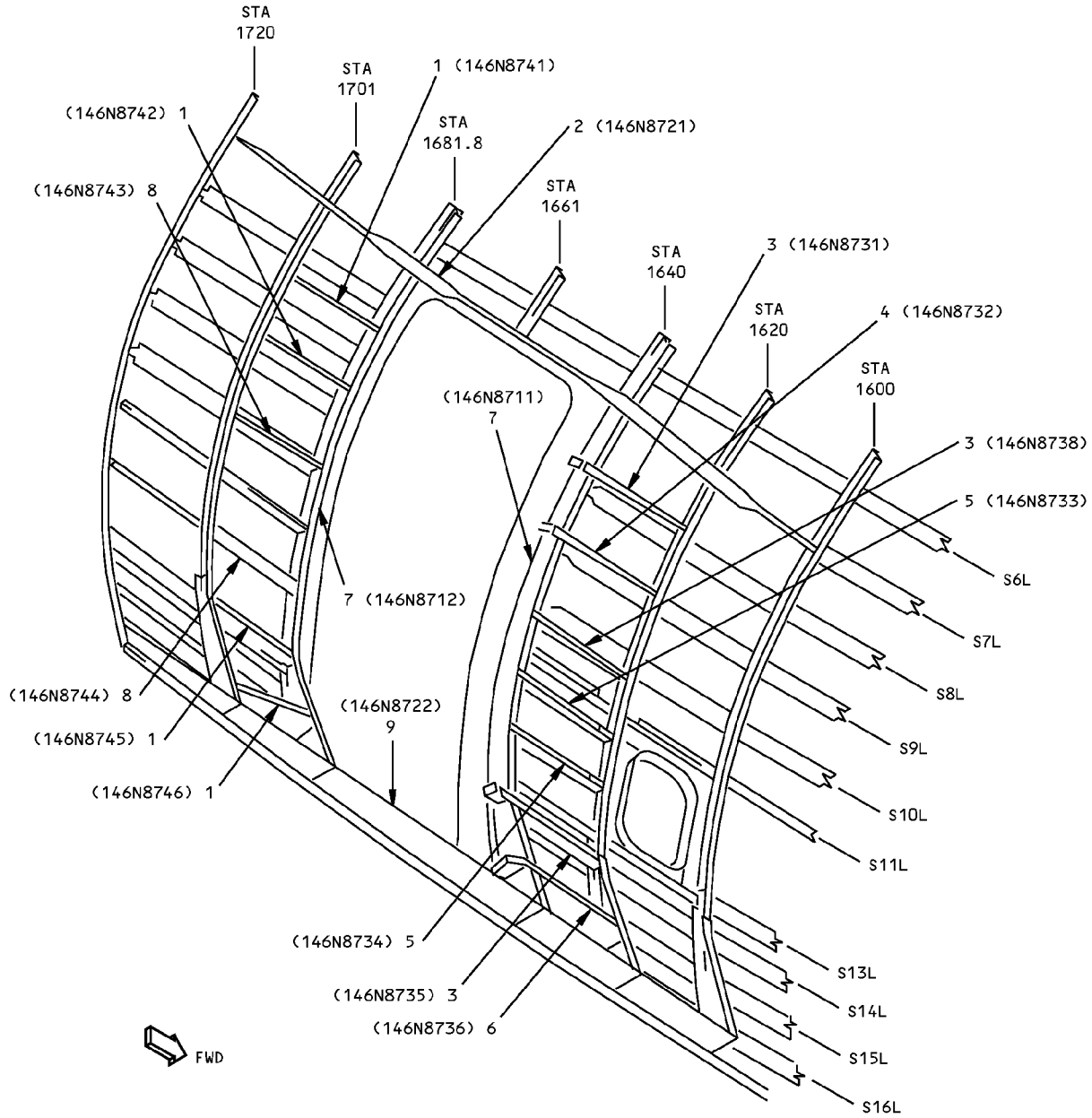


NOTES

- | | |
|--|--|
| <p>A FOR CUM LINE NUMBERS: 1 THRU 57 AND
OPTIONAL ON CUM LINE NUMBERS: 61,64,65,
66,71,73,78,80,82,84,86</p> <p>B ALL AIRPLANES NOT IN C</p> <p>C FOR CUM LINE NUMBERS: 1 THRU 57</p> <p>D FOR CUM LINE NUMBERS: 1 THRU 56</p> <p>E FOR ALL AIRPLANES NOT IN D</p> <p>F FOR AIRPLANES WITH OVERWING EMERGENCY EXITS
EXCEPT CUM LINE NUMBERS: 37,39,41,43 THRU
49, AND 61</p> | <p>G FOR AIRPLANES WITH NO. 3 EMERGENCY EXITS</p> <p>H FOR CUM LINE NUMBERS: 9,10,11,13,14,16,23,
24,25,29,30,32,33,34,50,52,54,58</p> <p>I FOR AIRPLANES WITH NO. 3 CARGO DOOR AND NOT
IN H</p> <p>J FOR CUM LINE NUMBERS: 1 THRU 497</p> <p>K OPTIONAL FOR CUM LINE NUMBERS: 1 THRU 497</p> <p>L FOR CUM LINE NUMBERS: 498 AND ON</p> <p>M FOR CUM LINE NUMBERS: 1 THRU 482</p> <p>N FOR AIRPLANES NOT LISTED IN M</p> |
|--|--|

**Section 46 Door Surround Structure Identification
Figure 1 (Sheet 1 of 9)**

**757-200
STRUCTURAL REPAIR MANUAL**



No. 4 PASSENGER DOOR
LEFT SIDE AS SHOWN
RIGHT SIDE OPPOSITE

DETAIL I



**Section 46 Door Surround Structure Identification
Figure 1 (Sheet 2 of 9)**



**757-200
STRUCTURAL REPAIR MANUAL**

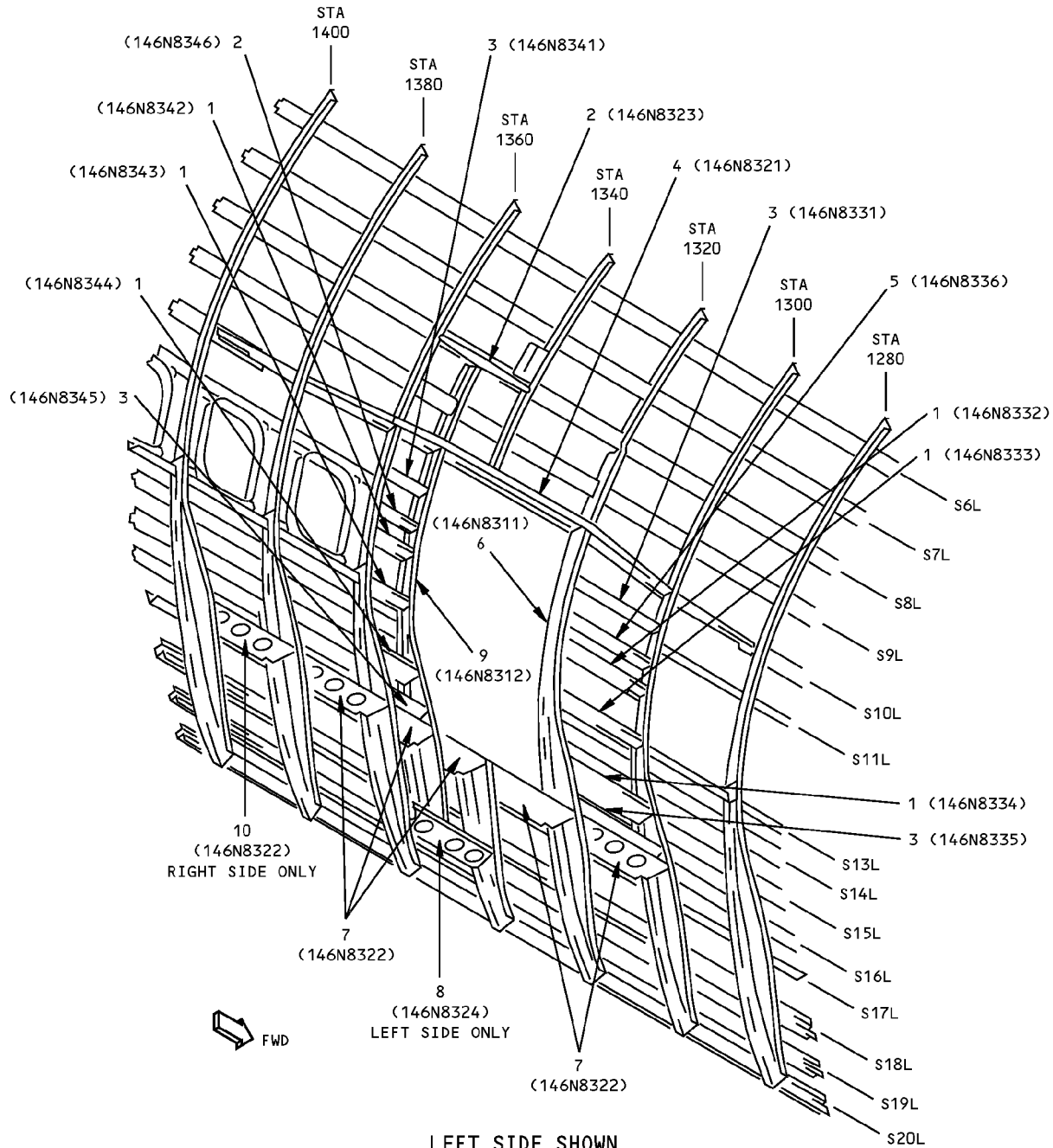
ITEM	DESCRIPTION	GAGE	MATERIAL	EFFECTIVITY
1	INTERCOSTAL	0.050	CLAD 7075-T6	
2	UPPER SILL CHORD		AND10136-2401 7075-T73	
	FWD WEB	0.056	CLAD 7075-T6	
	FWD WEB	0.063	CLAD 7075-T6	
	CTR WEB	0.080	CLAD 7075-T6	
	AFT WEB	0.063	CLAD 7075-T6	
	AFT WEB	0.050	CLAD 7075-T6	
3	INTERCOSTAL CHORD		BAC1500-6238 CLAD 7075-T6	
	WEB	0.050	CLAD 7075-T6	
4	INTERCOSTAL		7075-T73 FORGING OPTIONAL: 7075-T73 FORGED BLOCK	
5	INTERCOSTAL CHORD		BAC1503-100502 7075-T73	
	WEB	0.050	CLAD 7075-T6	
6	INTERCOSTAL CHORD		BAC1500-6238 CLAD 7075-T62	
	WEB	0.056	CLAD 7075-T6	
7	FRAME CHORD		BAC1514-2700 7075-T73 OPTIONAL: 7075-T73511	
	WEB	0.080	7075-T6	
8	INTERCOSTAL	0.045	CLAD 7075-T6	
9	LOWER SILL OUTER CHORD		BAC1506-2002 7075-T73 BAC1506-3785 7075-T73	
	INNER CHORD	0.090	15-5PH CRES HT TR TO 180-200 KSI	
	FWD WEB	0.050	CLAD 7075-T6	
	CTR WEB	0.056	CLAD 7075-T6	
	AFT WEB	0.071	CLAD 7075-T6	



LIST OF MATERIALS FOR DETAIL I

**Section 46 Door Surround Structure Identification
Figure 1 (Sheet 3 of 9)**

**757-200
STRUCTURAL REPAIR MANUAL**



LEFT SIDE SHOWN
RIGHT SIDE OPPOSITE
DETAIL II

LIST OF MATL

**Section 46 Door Surround Structure Identification
Figure 1 (Sheet 4 of 9)**



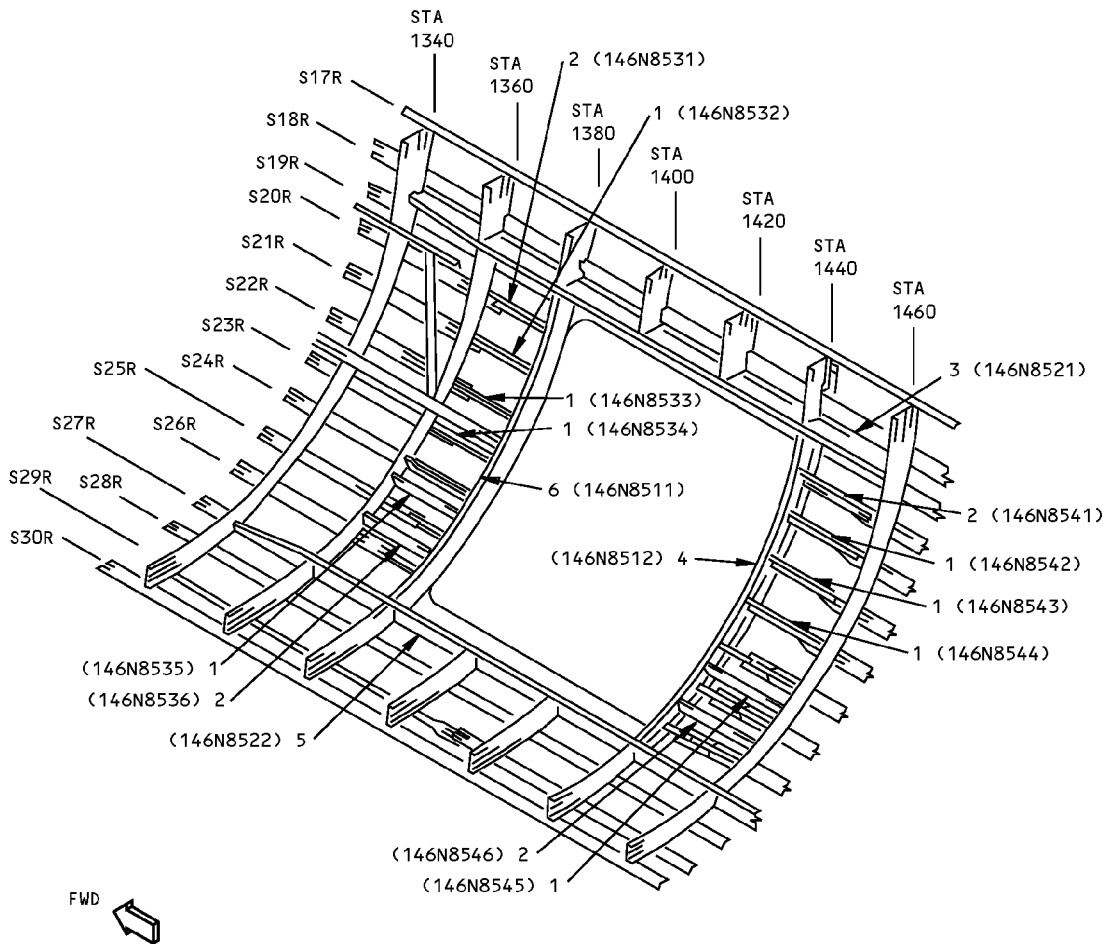
**757-200
STRUCTURAL REPAIR MANUAL**

ITEM	DESCRIPTION	GAGE	MATERIAL	EFFECTIVITY			
1	INTERCOSTAL	0.056	CLAD 2024-T42	<table border="1"> <tr><td>M</td></tr> <tr><td>M</td></tr> <tr><td>N</td></tr> </table>	M	M	N
M							
M							
N							
2	INTERCOSTAL	0.050	CLAD 7075-T6				
3	INTERCOSTAL	0.071	2024-T42				
4	UPPER SILL CHORD		BAC1508-250 7075-T73 OPTIONAL: BAC1505-101258 7075-T73 BAC1505-100690 7075-T73				
	FWD WEB	0.040	CLAD 7075-T6				
	AFT WEB	0.050	CLAD 7075-T6				
5	INTERCOSTAL	0.050	CLAD 7075-T62				
6	FWD FRAME OUTER CHORD INNER CHORD WEB	0.071	BAC1503-100675 7075-T73 BAC1505-100697 7075-T6511 7075-T6				
7	LOWER SILL OUTER CHORD INNER CHORD FWD WEB CTR WEB AFT WEB AFT WEB	0.100 0.032 0.063 0.050 0.036	BAC1506-3365 7075-T73511 7075-T6 CLAD 7075-T6 CLAD 7075-T6 CLAD 7075-T6 CLAD 7075-T6				
8	INTERCOSTAL	0.045	CLAD 7075-T6				
9	AFT SILL CHORD WEB	0.071	BAC1503-100675 7075-T73 7075-T6				
10	WEB	0.040	CLAD 7075-T6				

LIST OF MATERIALS FOR DETAIL II

**Section 46 Door Surround Structure Identification
Figure 1 (Sheet 5 of 9)**

**757-200
STRUCTURAL REPAIR MANUAL**



NO. 2 CARGO DOOR SURROUND STRUCTURE

RIGHT SIDE ONLY

DETAIL III



**Section 46 Door Surround Structure Identification
Figure 1 (Sheet 6 of 9)**

IDENTIFICATION 1
Page 6
Jan 20/2005

53-60-15

D634N201



**757-200
STRUCTURAL REPAIR MANUAL**

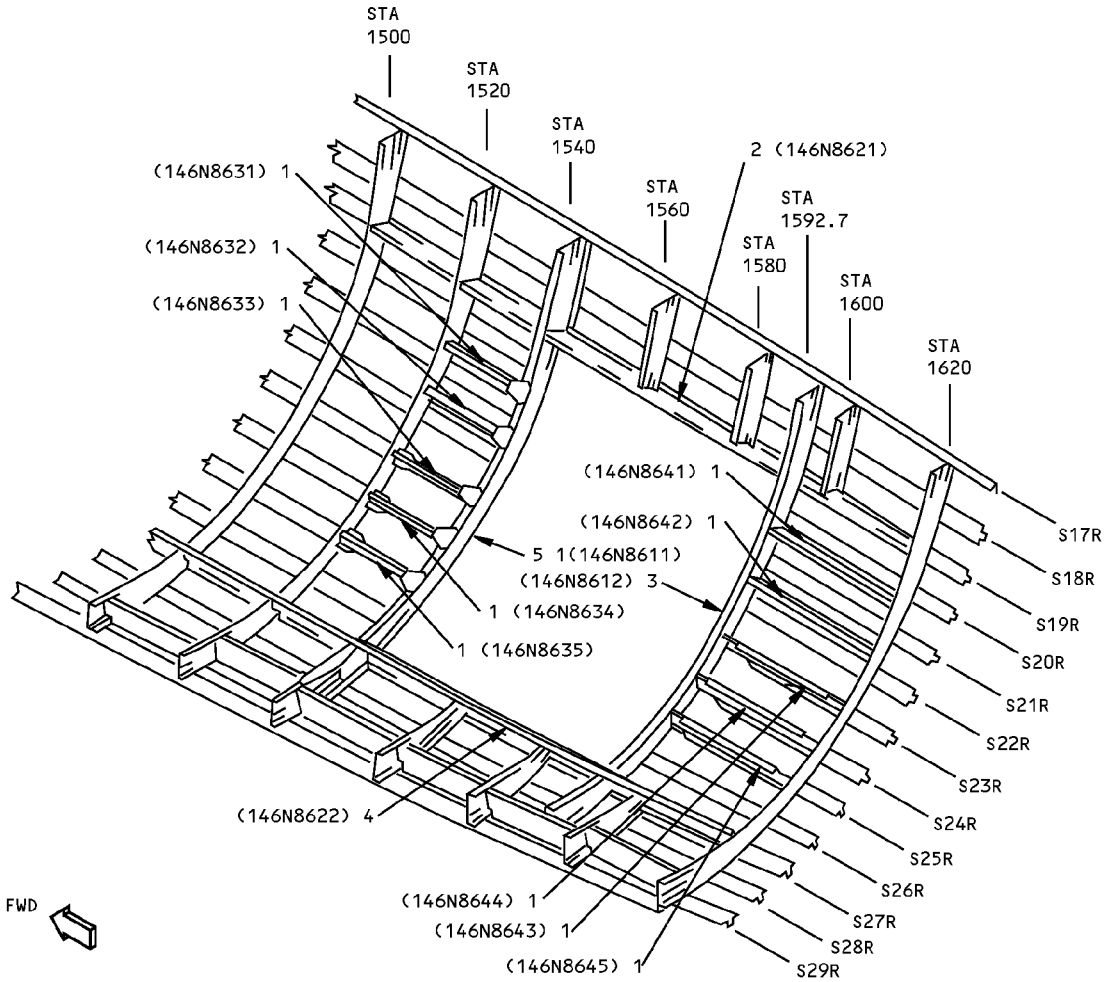
ITEM	DESCRIPTION	GAGE	MATERIAL	EFFECTIVITY
1	INTERCOSTAL	0.050	CLAD 7075-T6	
2	INTERCOSTAL	0.080	2024-T42	
3	UPPER SILL CHORD		BAC1514-2648 7075-T73511	
	FWD WEB	0.050	CLAD 7075-T6	
	CTR WEB	0.071	7075-T6	
	AFT WEB	0.063	7075-T6	
	AFT WEB	0.050	CLAD 7075-T6	
4	AFT FRAME OUTER CHORD		BAC1503-100275 7075-T73	D E D E D F G
			BAC1503-100275 2024-T42	
	INNER CHORD		BAC1503-100698 7075-T73	
			BAC1503-100698 2024-T73	
	WEB	0.071	7075-T6	
		0.080	2024-T3	
		0.080	2024-T42	
5	LOWER SILL OUTER CHORD		BAC1506-1945 7075-T73	
	INNER CHORD		BAC1506-3290 7075-T73511	
	FWD WEB	0.080	7075-T6	
	FWD WEB	0.063	7075-T6	
	CTR WEB	0.071	7075-T6	
	AFT WEB	0.063	7075-T6	
	AFT WEB	0.050	CLAD 7075-T6	
6	FWD FRAME OUTER CHORD		BAC1503-100275 7075-T73	A B C B C B
			BAC1503-100275 2024-T42	
	INNER CHORD		BAC1505-100849 7075-T73	
			BAC1505-100849 2024-T42	
	WEB	0.071	7075-T6	
		0.080	2024-T3	

LIST OF MATERIALS FOR DETAIL III

**Section 46 Door Surround Structure Identification
Figure 1 (Sheet 7 of 9)**

**757-200
STRUCTURAL REPAIR MANUAL**

REF DWG
143N5520



**NO. 3 CARGO DOOR SURROUND STRUCTURE
(RIGHT SIDE ONLY)**

DETAIL IV

LIST OF
MATL

**Section 46 Door Surround Structure Identification
Figure 1 (Sheet 8 of 9)**

IDENTIFICATION 1
Page 8
Jan 20/2005

53-60-15

D634N201



**757-200
STRUCTURAL REPAIR MANUAL**

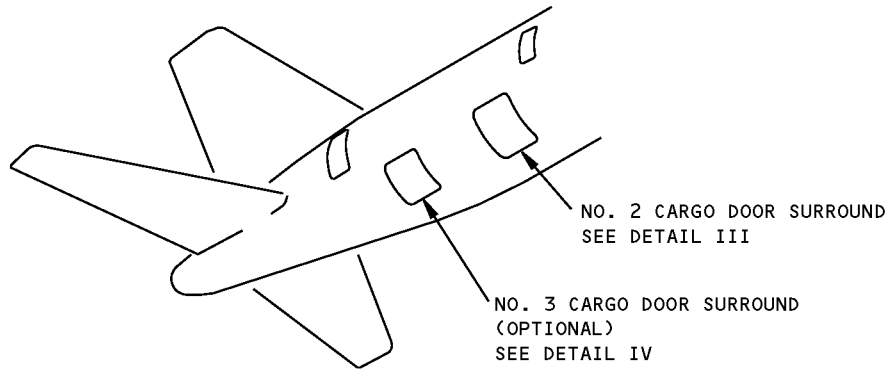
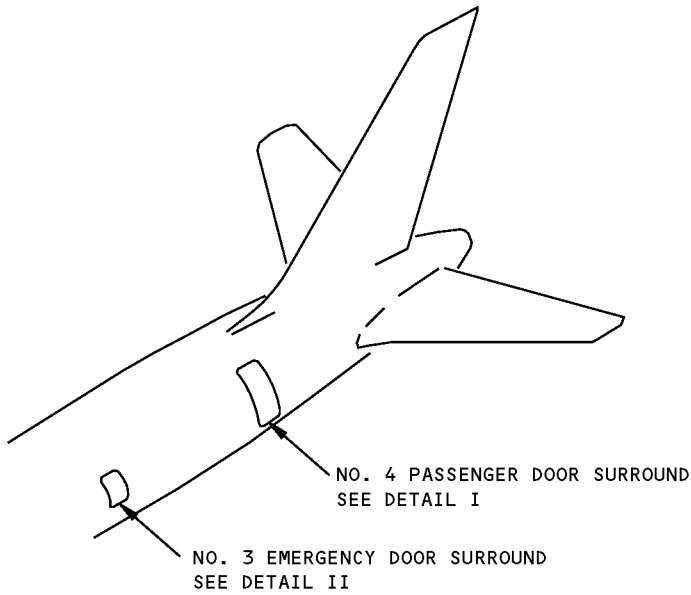
ITEM	DESCRIPTION	GAGE	MATERIAL	EFFECTIVITY
1	INTERCOSTAL	0.050	CLAD 7075-T6	
2	UPPER SILL			
	CHORD		AND10135-2006 7075-T73511	
	FWD WEB	0.050	CLAD 7075-T6	
	CTR WEB	0.056	CLAD 7075-T6	
	AFT WEB	0.071	7075-T6	
3	AFT FRAME			
	OUTER CHORD		BAC1503-100744 7075-T73	H I H I H I
			BAC1503-100744 2024-T42	
	INNER CHORD		BAC1503-100745 7075-T73	
			BAC1503-100745 2024-T42	
	WEB	0.071	7075-T6	
		0.080	2024-T3	
4	LOWER SILL			
	OUTER CHORD		AND10136-2406 7075-T73511	
	INNER CHORD		BAC1506-3453 7075-T73511	
	FWD WEB	0.040	CLAD 7075-T6	
	FWD WEB	0.050	CLAD 7075-T6	
	CTR WEB	0.071	7075-T6	
	AFT WEB	0.063	7075-T6	
	AFT WEB	0.050	CLAD 7075-T6	
5	FWD FRAME			
	OUTER CHORD		BAC1503-100744 7075-T73	H I H I H I
			BAC1503-100744 2024-T42	
	INNER CHORD		BAC1505-100849 7075-T73	
			BAC1505-100849 2024-T42	
	WEB	0.071	7075-T6	
		0.080	2024-T3	

LIST OF MATERIALS FOR DETAIL IV

**Section 46 Door Surround Structure Identification
Figure 1 (Sheet 9 of 9)**

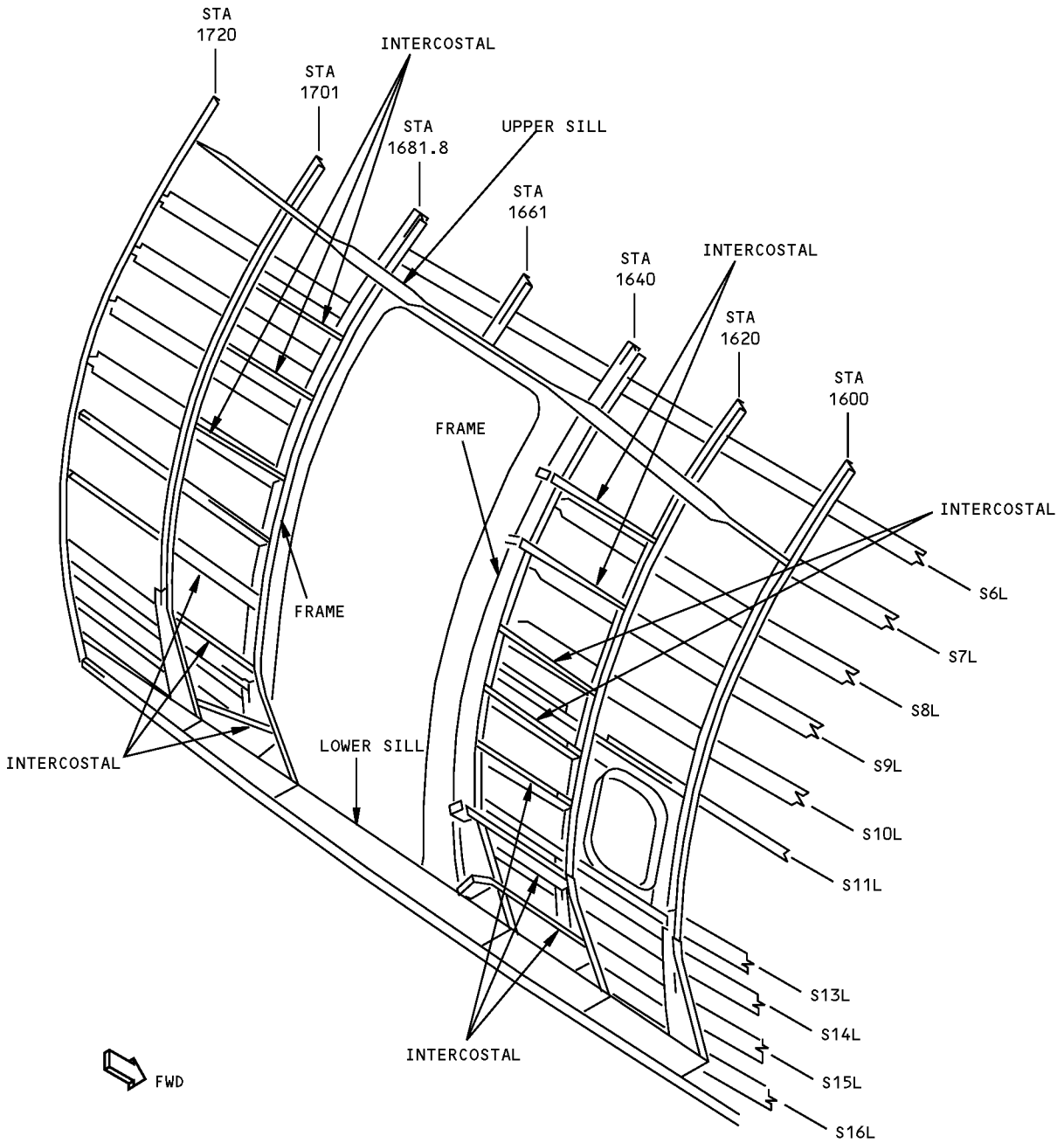
757-200
STRUCTURAL REPAIR MANUAL

ALLOWABLE DAMAGE 1 - SECTION 46 - DOOR SURROUND STRUCTURE



Section 46 Door Surround Structure Allowable Damage
Figure 101 (Sheet 1 of 7)

**757-200
STRUCTURAL REPAIR MANUAL**

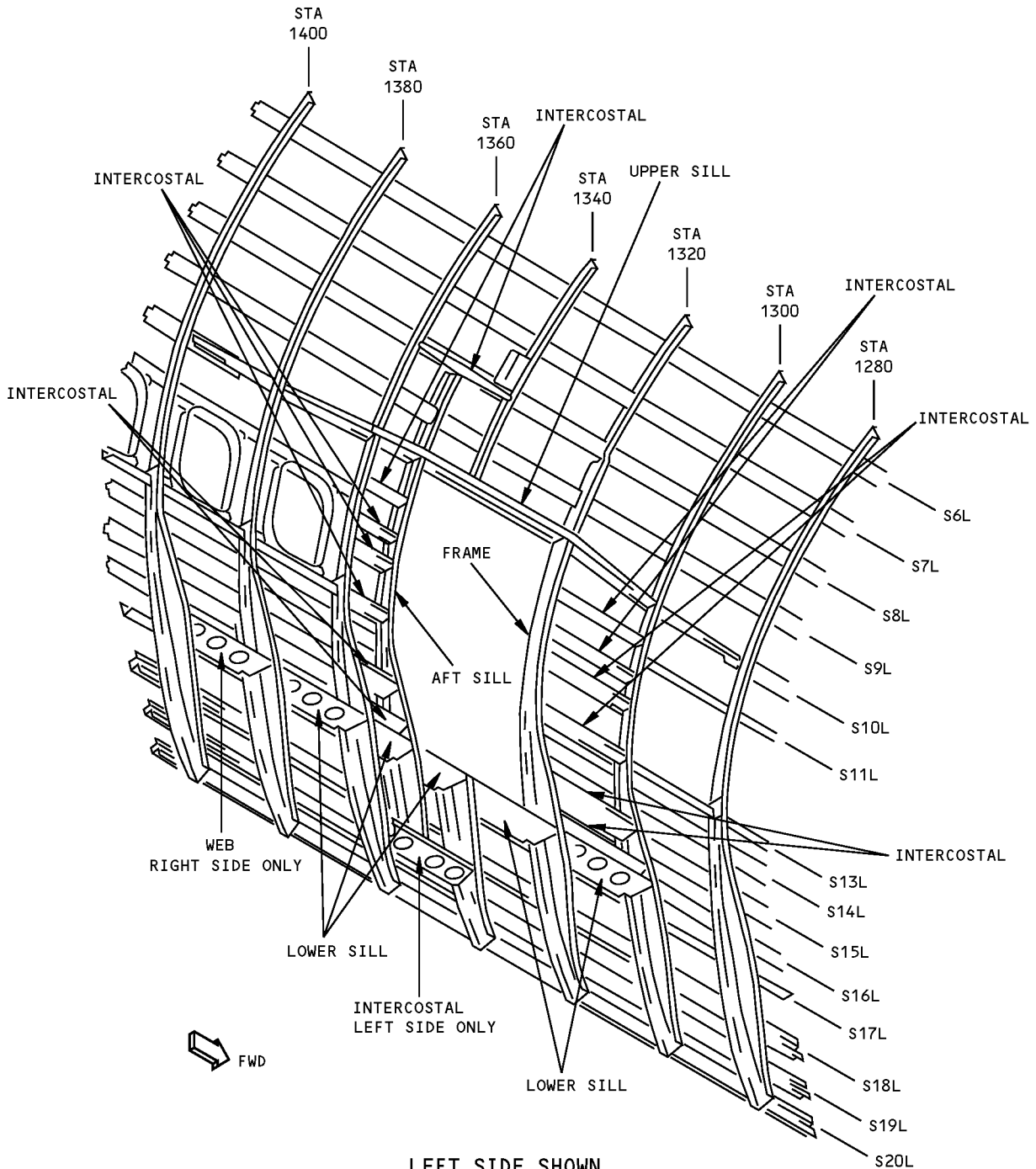


LEFT SIDE AS SHOWN
RIGHT SIDE OPPOSITE

DETAIL I

**Section 46 Door Surround Structure Allowable Damage
Figure 101 (Sheet 2 of 7)**

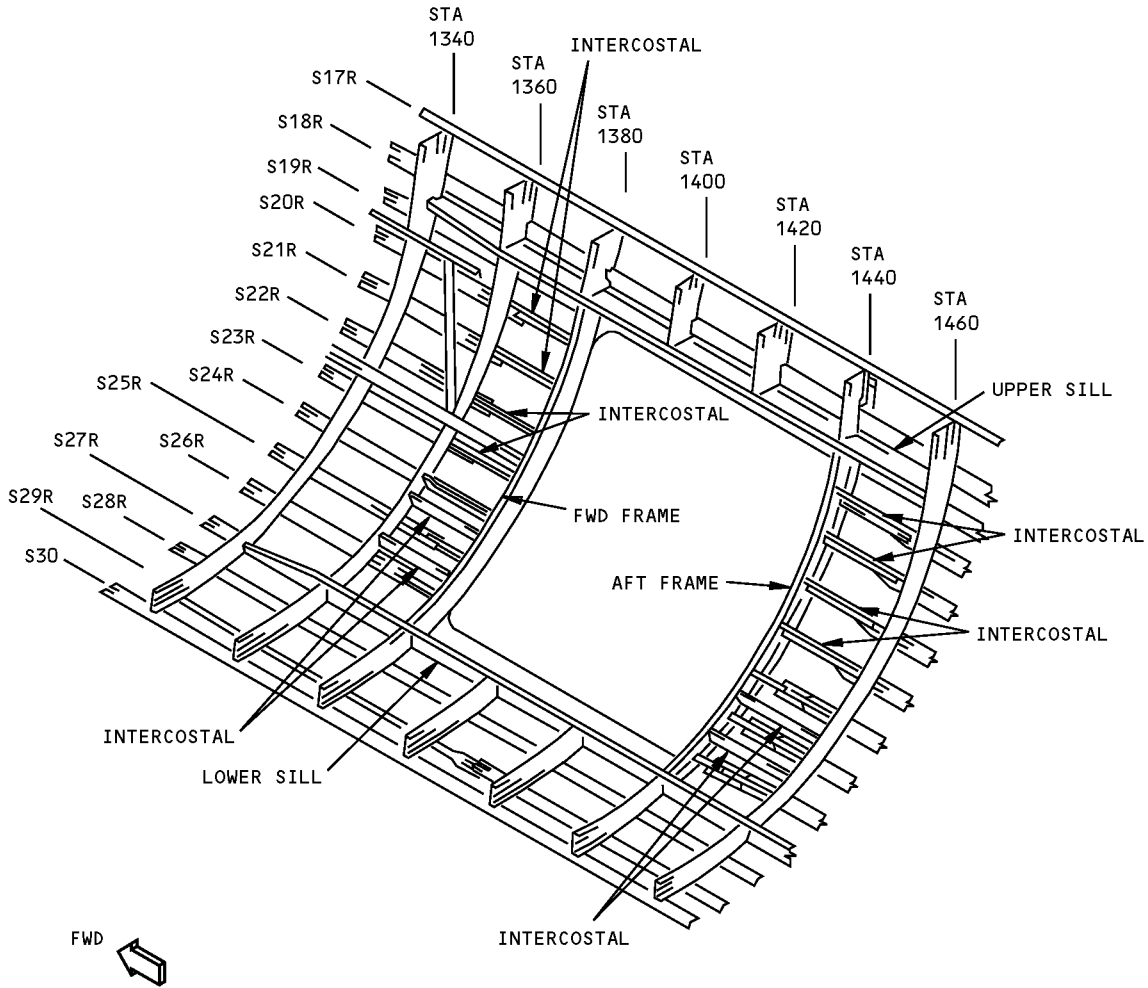
**757-200
STRUCTURAL REPAIR MANUAL**



LEFT SIDE SHOWN
RIGHT SIDE OPPOSITE
DETAIL II

**Section 46 Door Surround Structure Allowable Damage
Figure 101 (Sheet 3 of 7)**

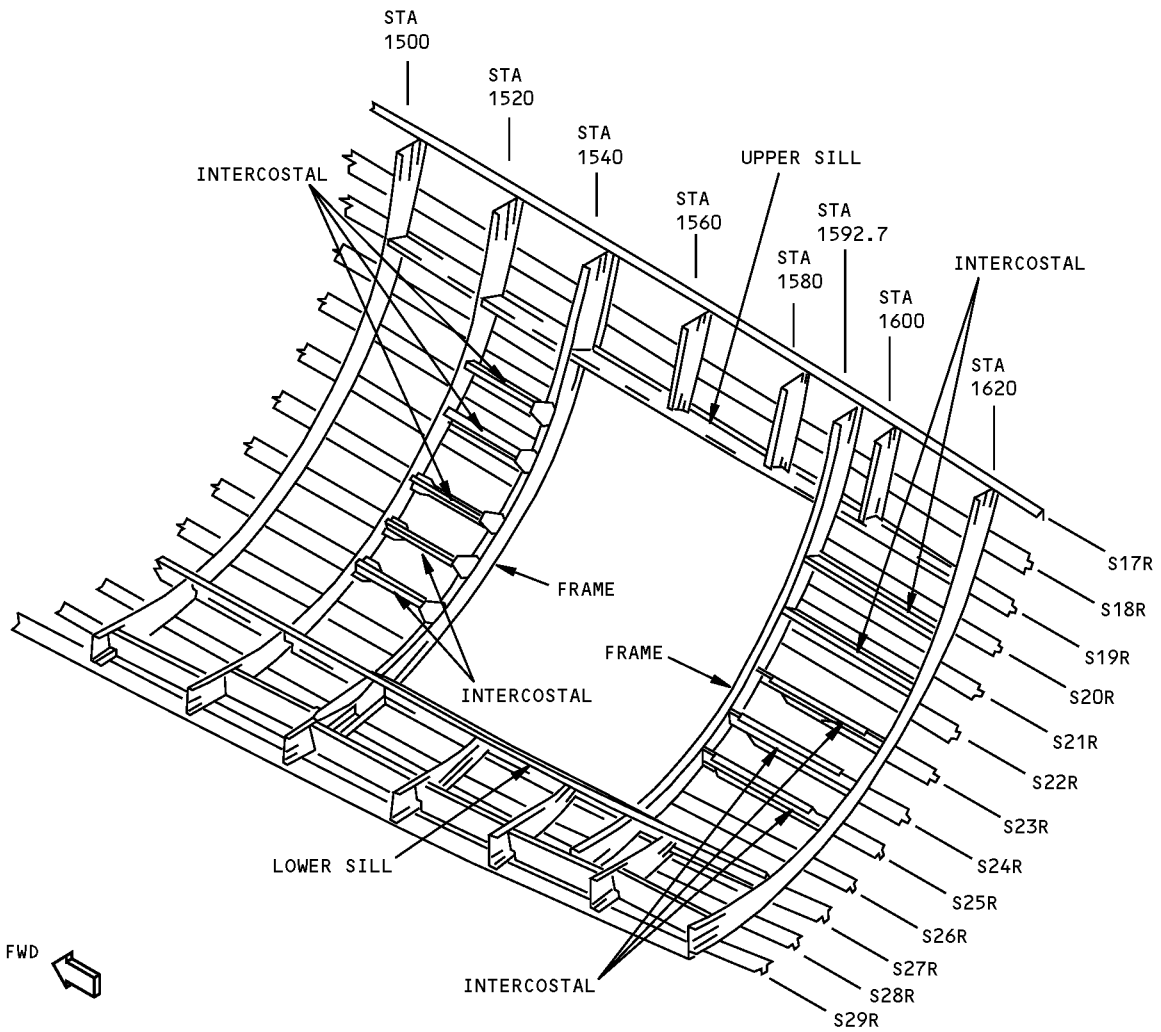
**757-200
STRUCTURAL REPAIR MANUAL**



**RIGHT SIDE ONLY
DETAIL III**

**Section 46 Door Surround Structure Allowable Damage
Figure 101 (Sheet 4 of 7)**

**757-200
STRUCTURAL REPAIR MANUAL**



RIGHT SIDE ONLY
DETAIL IV

**Section 46 Door Surround Structure Allowable Damage
Figure 101 (Sheet 5 of 7)**

**757-200
STRUCTURAL REPAIR MANUAL**

DESCRIPTION	CRACKS	NICKS, GOUGES AND CORROSION	DENTS	HOLES AND PUNCTURES
SILLS CHORDS WEBS	A A	B D B	NOT PERMITTED SEE DETAIL VII	NOT PERMITTED C
FRAMES CHORDS WEBS	A A	B B	NOT PERMITTED SEE DETAIL VII	NOT PERMITTED C
INTERCOSTALS CHORDS WEBS	A A	B B	NOT PERMITTED SEE DETAIL VII	NOT PERMITTED C

NOTES

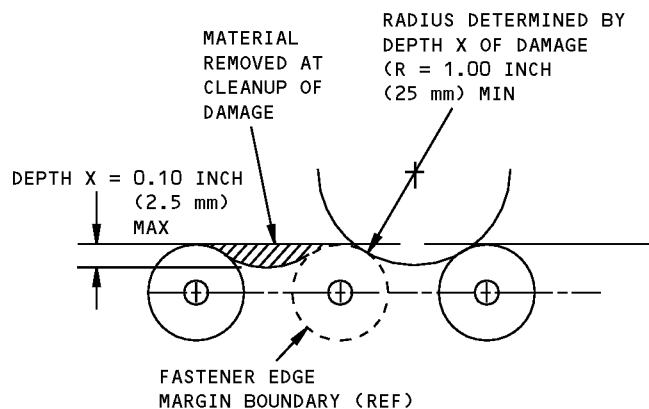
- THIS ALLOWABLE DAMAGE DATA IS APPLICABLE TO PASSENGER AIRPLANES ONLY.
- REFER TO SRM 53-00-01 FOR FUSELAGE SKIN ALLOWABLE DAMAGE DATA.
- REFINISH REWORKED AREAS AS GIVEN IN AMM 51-20.

A CRACKS ARE NOT PERMITTED EXCEPT FOR EDGE CRACKS WHICH MUST BE REMOVED AS GIVEN IN DETAILS V AND IX.

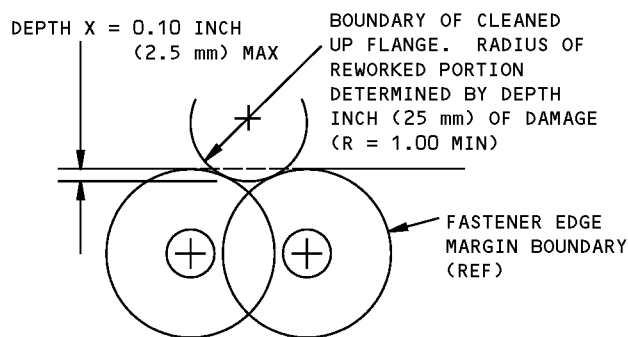
B REMOVE DAMAGE AS GIVEN IN DETAILS V, VI, VIII, AND IX.

C CLEAN OUT DAMAGE UP TO 0.25 INCH (6 mm) MAX DIA AND NOT CLOSER THAN 1.0 INCH (25 mm) TO FASTENER HOLE OR OTHER DAMAGE. FILL HOLE WITH A 2117-T3 OR T4 ALUMINUM RIVET INSTALLED WET WITH BMS 5-95 SEALANT. ALL OTHER HOLES MUST BE REPAIRED.

D IF THE DAMAGE TO THE LOWER SILL CHORD BETWEEN STATIONS 1378 AND 1442 IS MORE THAN PERMITTED IN THIS FIGURE, REFER TO ALLOWABLE DAMAGE 2.



DAMAGE CLEANUP OF EDGES WHERE
FASTENER EDGE MARGINS DO NOT OVERLAP

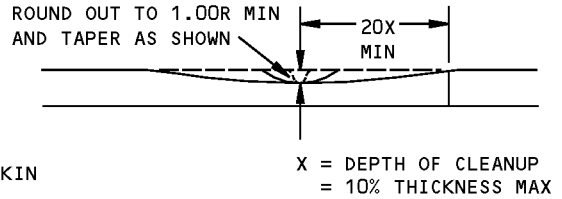
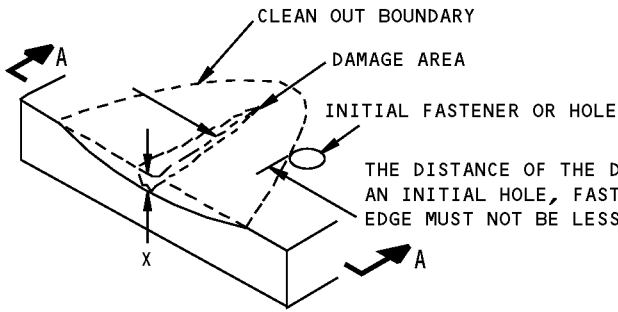


DAMAGE CLEANUP OF EDGES WHERE
FASTENER EDGE MARGINS OVERLAP

DETAIL V

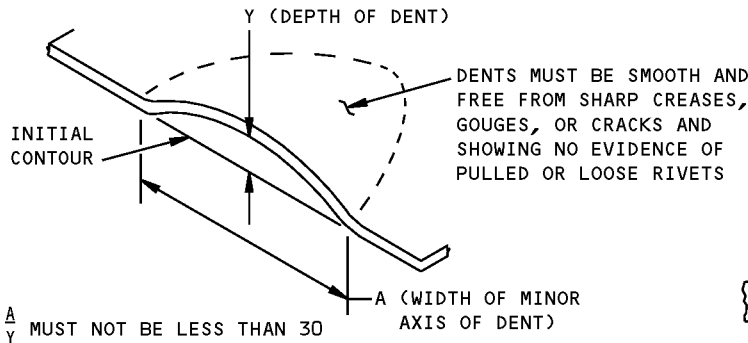
**Section 46 Door Surround Structure Allowable Damage
Figure 101 (Sheet 6 of 7)**

**757-200
STRUCTURAL REPAIR MANUAL**



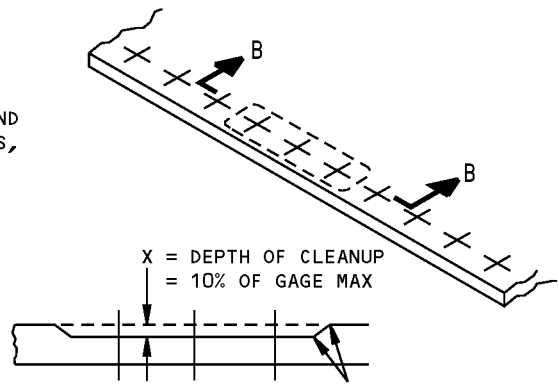
SECTION A-A

**REMOVAL OF NICK, GOUGE AND SCRATCH DAMAGE ON A SURFACE
DETAIL VI**



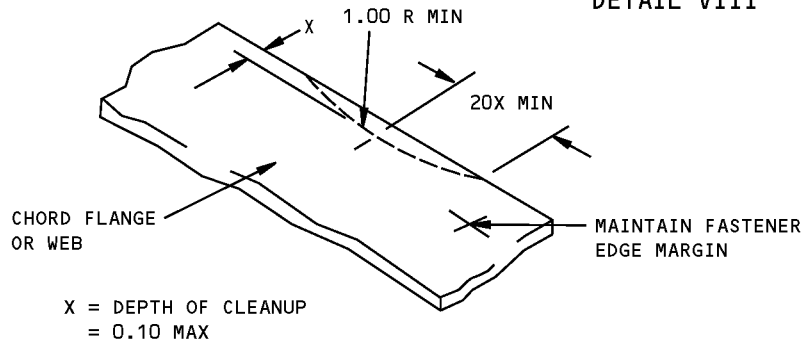
$\frac{A}{Y}$ MUST NOT BE LESS THAN 30
Y = 0.125 MAX

**ALLOWABLE DAMAGE FOR DENT
DETAIL VII**



SECTION B-B

**CORROSION CLEANUP
DETAIL VIII**



**REMOVAL OF NICK OR CRACK DAMAGE ON AN EDGE
DETAIL IX**

**Section 46 Door Surround Structure Allowable Damage
Figure 101 (Sheet 7 of 7)**

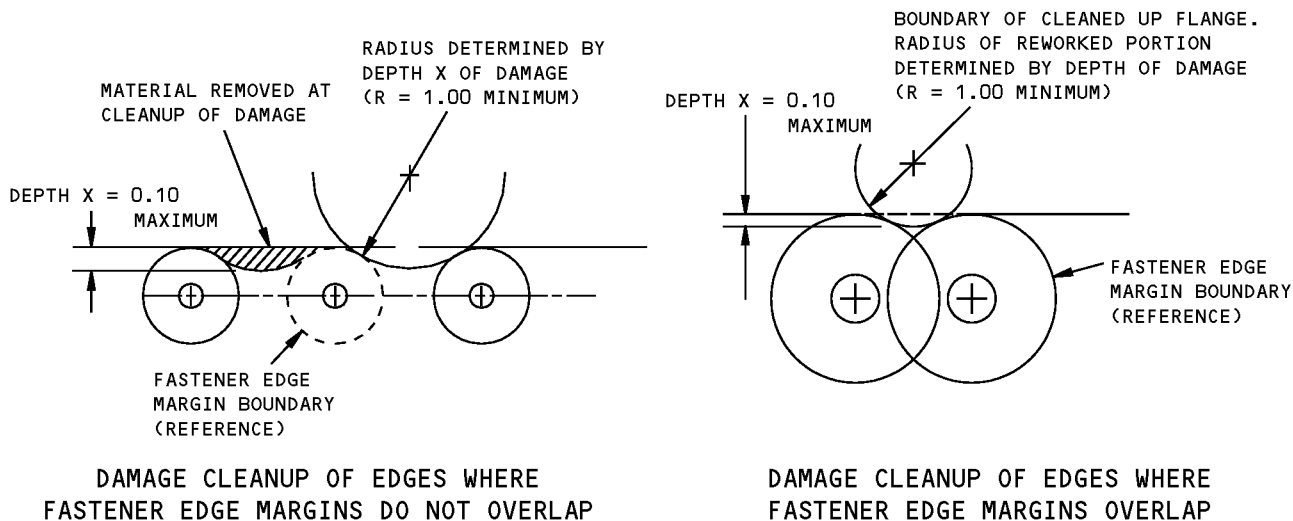
STRUCTURAL REPAIR MANUAL

ALLOWABLE DAMAGE 2 - SECTION 46 - CARGO DOOR NUMBER 2 LOWER SILL, INBOARD CHORD STATIONS 1378 - 1442

DESCRIPTION	CRACKS	NICKS, GOUGES AND CORROSION	DENTS	HOLES AND PUNCTURES
SILLS INBOARD CHORD	A	B	NOT PERMITTED	NOT PERMITTED

NOTES

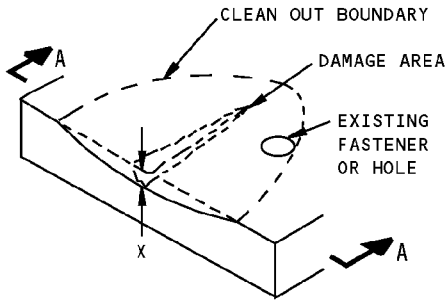
- THE ALLOWABLE DAMAGE DATA IS APPLICABLE TO PASSENGER AIRPLANES ONLY.
 - SEE SRM 53-00-01 FOR THE FUSELAGE SKIN ALLOWABLE DAMAGE DATA.
 - REFINISH REWORKED AREAS PER AMM 51-20.
 - IF THERE IS CORROSION AT NUTPLATE LOCATIONS, BLEND THE FLAT SURFACE UNDER THE NUTPLATE TO ALLOW PROPER SEATING OF THE NUTPLATE.
 - APPLY A CHEMICAL CONVERSION COATING TO THE AREA OF DAMAGE REMOVAL. REFER TO SRM 51-20-01.
 - APPLY TWO LAYERS OF BMS 10-11, TYPE I PRIMER TO THE AREA OF DAMAGE REMOVAL. REFER TO SOPM 20-41-02.
 - APPLY ONE LAYER OF BMS 3-29 CORROSION INHIBITING COMPOUND TO THE DOOR SILL AREA. REFER TO SRM 51-20-01.
- A** CRACKS ARE NOT PERMITTED EXCEPT FOR EDGE CRACKS WHICH MUST BE REMOVED PER DETAILS I AND V.
 - B** REMOVE DAMAGE PER DETAILS I, II, III OR IV, AND V. SURFACE FINISH REQUIRED 63 MICRO-INCHES R_a OR BETTER.
 - C** IF THE UPPER HORIZONTAL SURFACE OF THE CHORD (COMMON TO THE THRESHOLD) NEEDS TO BE BLENDED, FILL THE BLENDS WITH BMS 5-95 SEALANT. REFER TO SRM 51-20-06.
 - D** THE THICKNESS SHOWN ARE THE MINIMUM REQUIRED THICKNESS REMAINING AFTER CORROSION REMOVAL FROM EITHER ONE OR BOTH SURFACES ON A FLANGE.
 - E** SOLID OR LAMINATED SHIM. MAKE THE MATERIAL AND THICKNESS FOR THE SHIM THE SAME AS THE REMOVED MATERIAL.



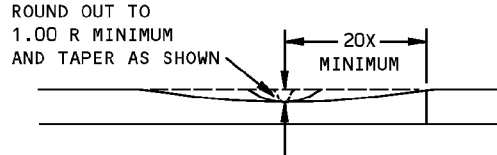
DETAIL I

Section 46 Cargo Door Number 2 Lower Sill, Inboard Chord Stations 1378 - 1442 Allowable Damage Figure 101 (Sheet 1 of 2)

STRUCTURAL REPAIR MANUAL

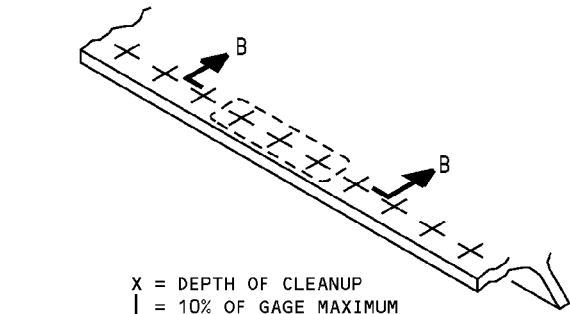


**REMOVAL OF NICK, GOUGE AND SCRATCH DAMAGE ON A SURFACE
DETAIL II**



X = DEPTH OF CLEANUP = 10% THICKNESS MAXIMUM

SECTION A-A

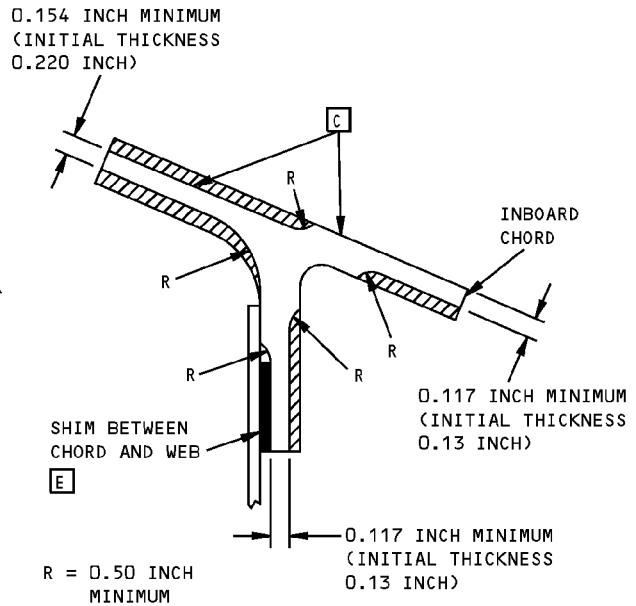


X = DEPTH OF CLEANUP = 10% OF GAGE MAXIMUM

SMOOTH BLEND-OUT RADIUS 0.50 INCH MINIMUM. CORROSION CLEANUP AROUND ANY THREE FASTENERS IN TEN IS PERMITTED TO MAXIMUM DEPTH

SECTION B-B

**CORROSION CLEANUP
SEE DETAIL IV; EXPANDED DEPTH CLEANUP
LOCATION FOR STATION 1378 TO 1442
DETAIL III**



0.154 INCH MINIMUM (INITIAL THICKNESS 0.220 INCH)

INBOARD CHORD

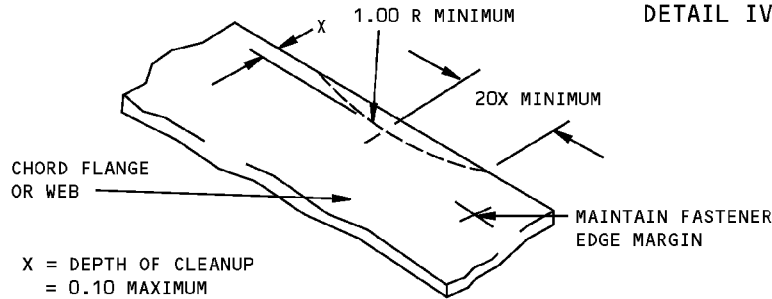
0.117 INCH MINIMUM (INITIAL THICKNESS 0.13 INCH)

SHIM BETWEEN CHORD AND WEB
E

0.117 INCH MINIMUM (INITIAL THICKNESS 0.13 INCH)

R = 0.50 INCH MINIMUM

**STATION 1378 TO 1442 ONLY (TYPICAL)
DETAIL IV D**



X = DEPTH OF CLEANUP = 0.10 MAXIMUM

**REMOVAL OF NICK OR CRACK DAMAGE ON AN EDGE
DETAIL V**

**Section 46 Cargo Door Number 2 Lower Sill, Inboard Chord Stations 1378 - 1442 Allowable Damage
Figure 101 (Sheet 2 of 2)**



**757-200
STRUCTURAL REPAIR MANUAL**

REPAIR GENERAL - DOOR SURROUND STRUCTURE - SERVICE BULLETIN LIST

SERVICE BULLETIN REPAIRS

The following Service Bulletins contain repairs which are available for use where specific damage has been encountered. Usually, the Service Bulletin also covers preventive modification data which operators are encouraged to use to eliminate the need for repair.

DAMAGED AREA	CUM LINE NUMBER EFFECTIVITY	SB NUMBER
No. 4 PASSENGER DOOR AFT FRAME, OUTBD CHORD, S-16 TO S-18	1 THRU 82,84,85,87,91,92, 95,101	53-0024

**Service Bulletin Repairs
Figure 201**

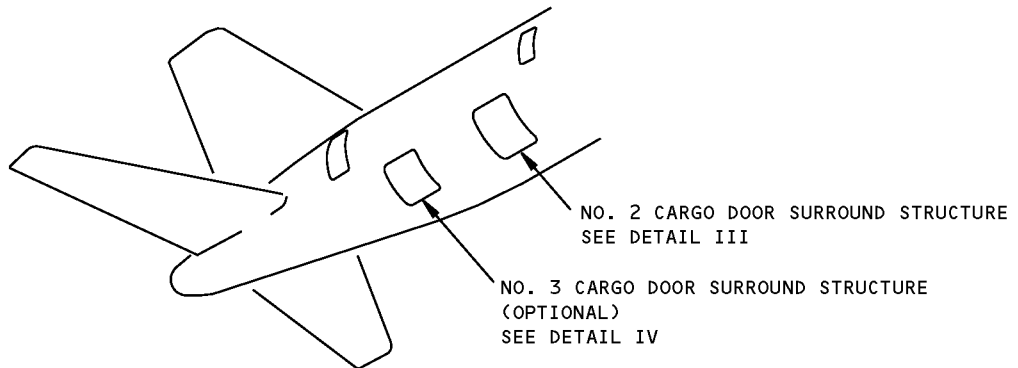
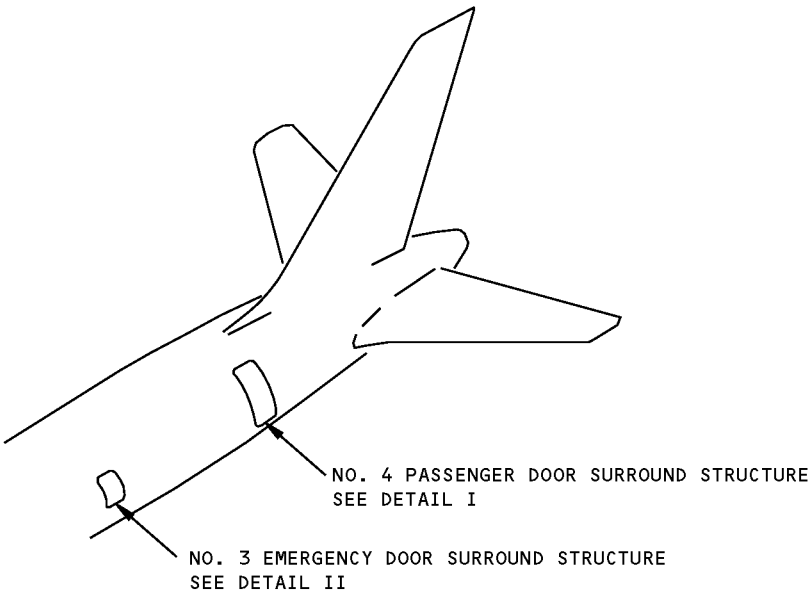
D634N201

53-60-15

REPAIR GENERAL
Page 201
Jan 20/2005

757-200
STRUCTURAL REPAIR MANUAL

REPAIR 1 - SECTION 46 - DOOR SURROUND STRUCTURE

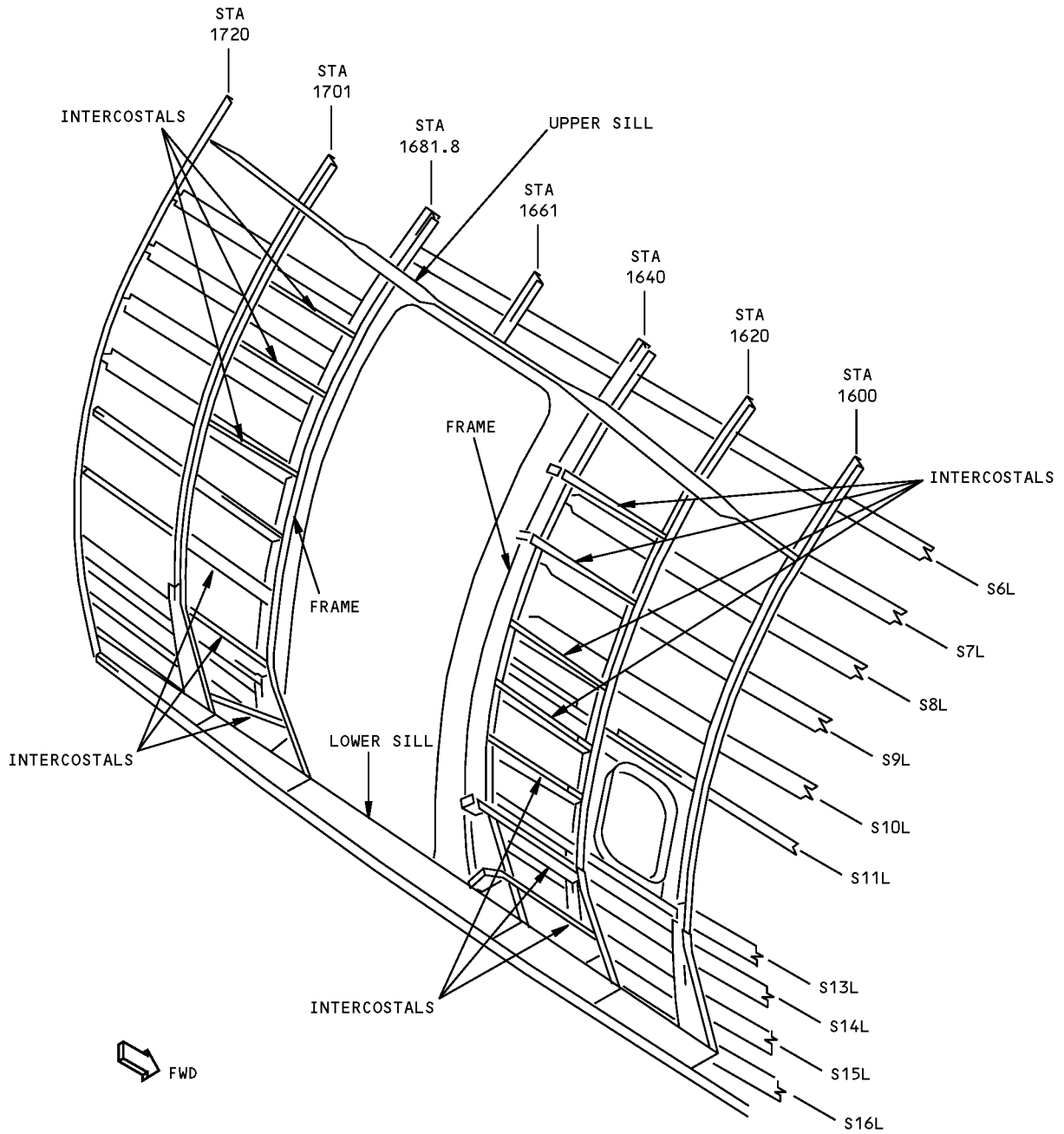


NOTES

- THIS REPAIR DATA IS APPLICABLE TO PASSENGER AIRPLANES ONLY
- DAMAGED COMPONENTS IN DOOR SURROUND STRUCTURE MAY BE REPLACED OR REPAIRED. IF REPAIRS ARE TO BE MADE, REFER TO SRM 51-70 FOR TYPICAL WEB, AND EXTRUDED SECTION REPAIRS

Section 46 Door Surround Structure Repair
Figure 201 (Sheet 1 of 5)

**757-200
STRUCTURAL REPAIR MANUAL**

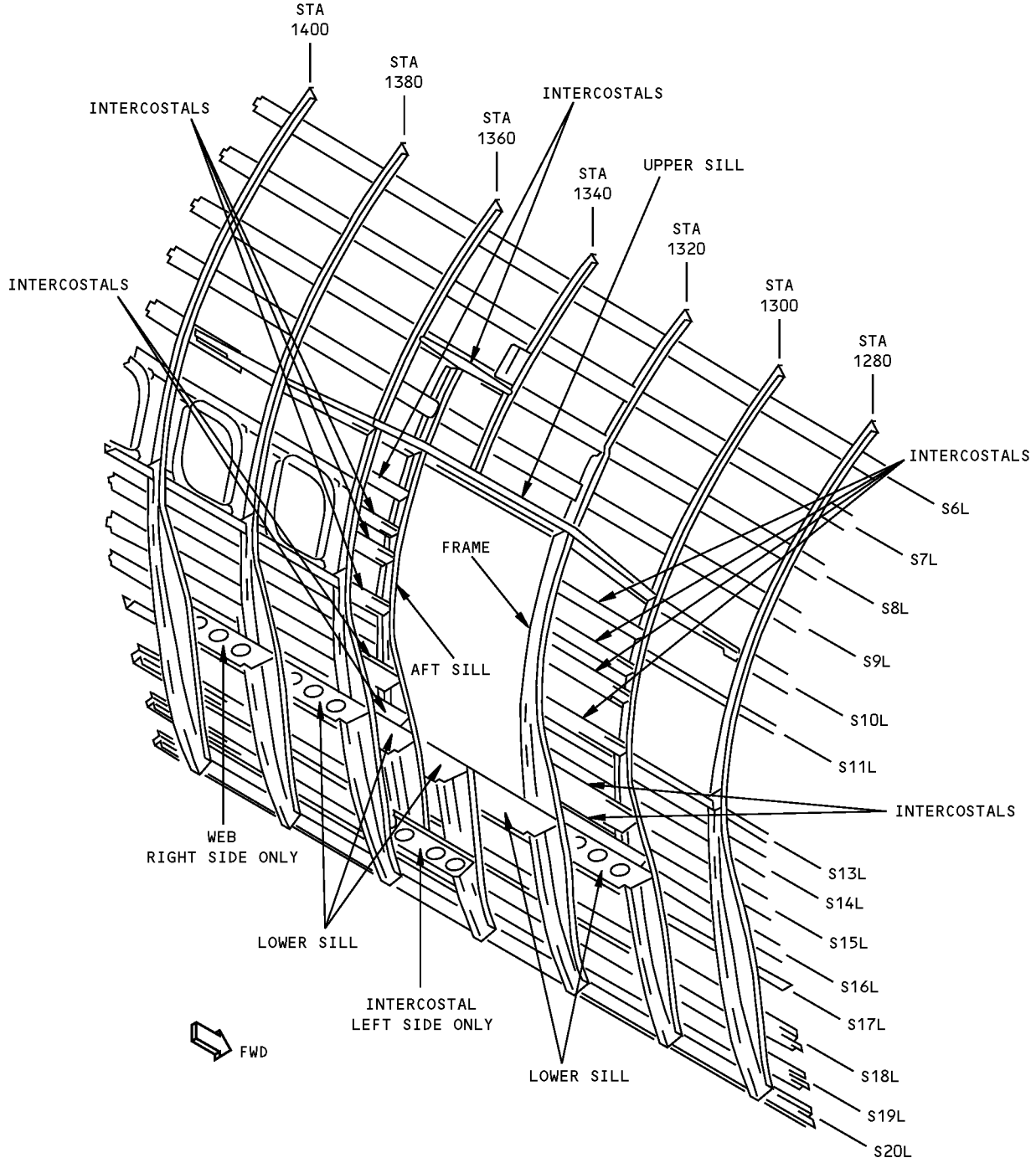


LEFT SIDE AS SHOWN
RIGHT SIDE OPPOSITE

DETAIL I

**Section 46 Door Surround Structure Repair
Figure 201 (Sheet 2 of 5)**

**757-200
STRUCTURAL REPAIR MANUAL**

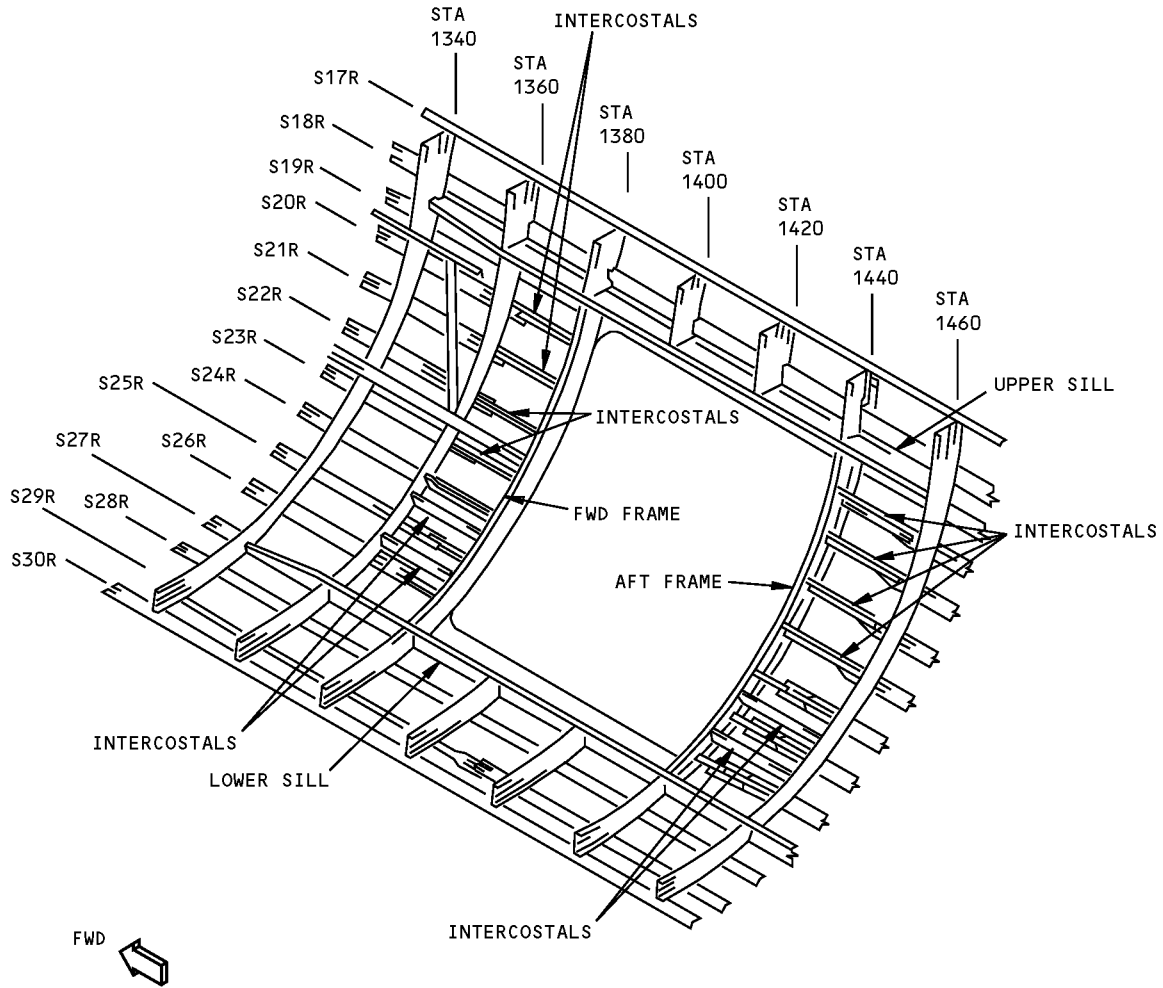


LEFT SIDE SHOWN
RIGHT SIDE OPPOSITE

DETAIL II

**Section 46 Door Surround Structure Repair
Figure 201 (Sheet 3 of 5)**

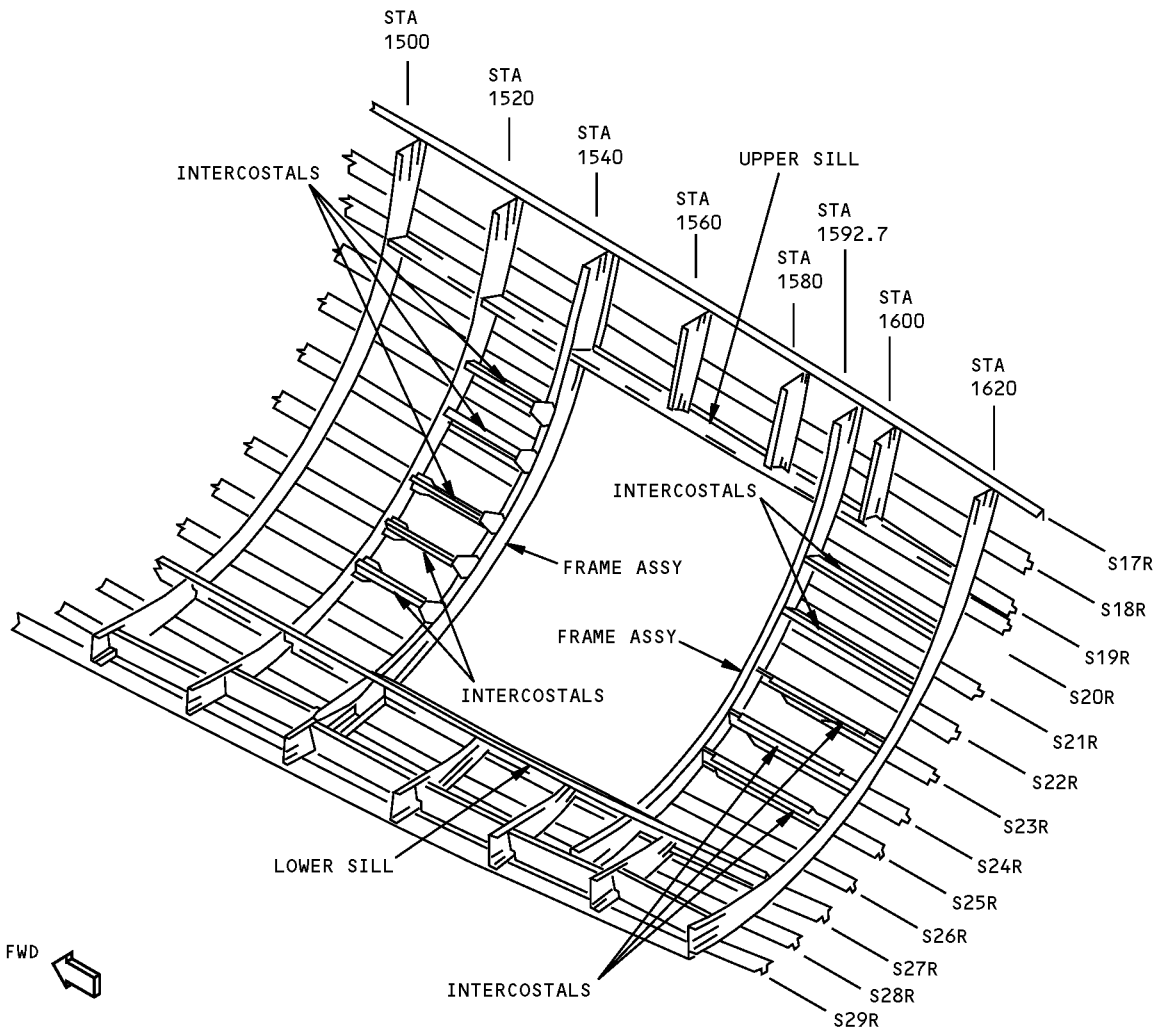
**757-200
STRUCTURAL REPAIR MANUAL**



RIGHT SIDE ONLY
DETAIL III

**Section 46 Door Surround Structure Repair
Figure 201 (Sheet 4 of 5)**

**757-200
STRUCTURAL REPAIR MANUAL**

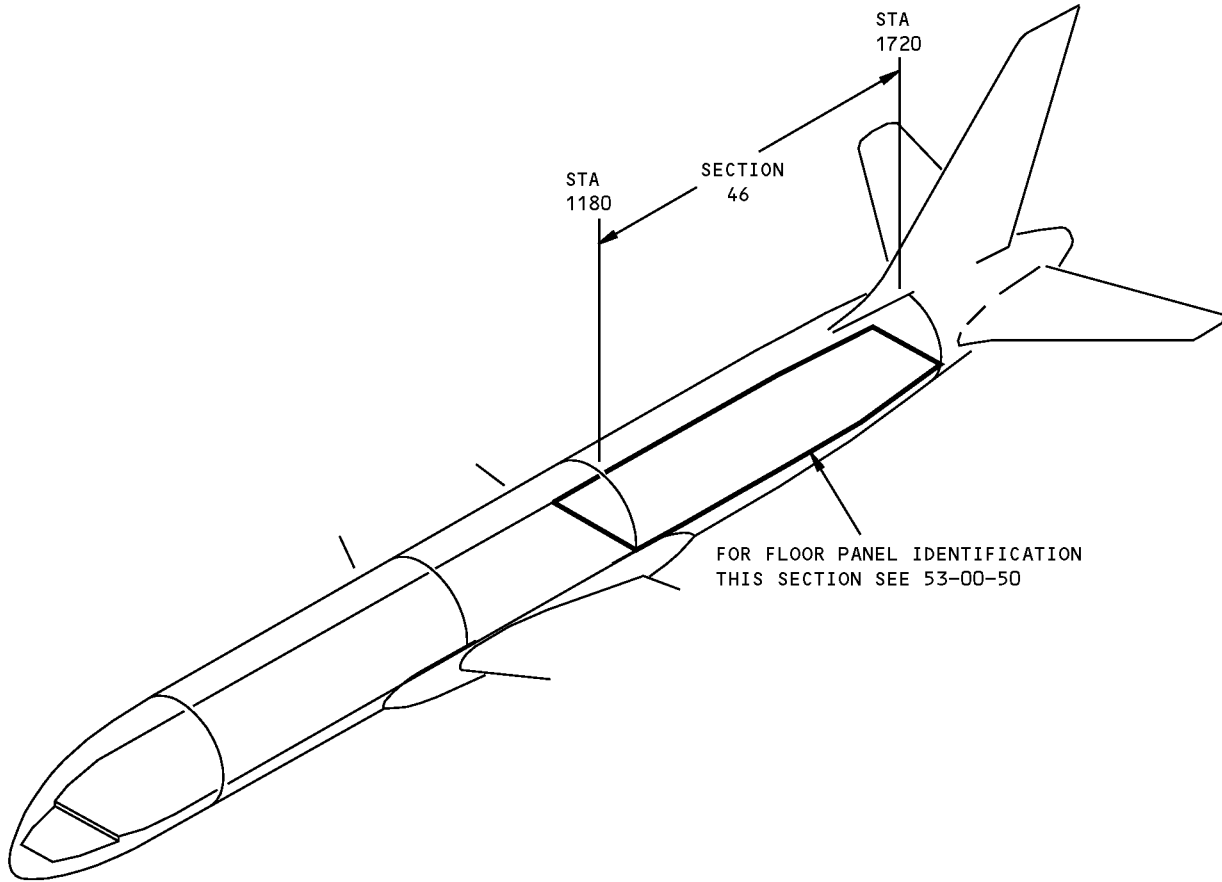


RIGHT SIDE ONLY
DETAIL IV

Section 46 Door Surround Structure Repair
Figure 201 (Sheet 5 of 5)

757-200
STRUCTURAL REPAIR MANUAL

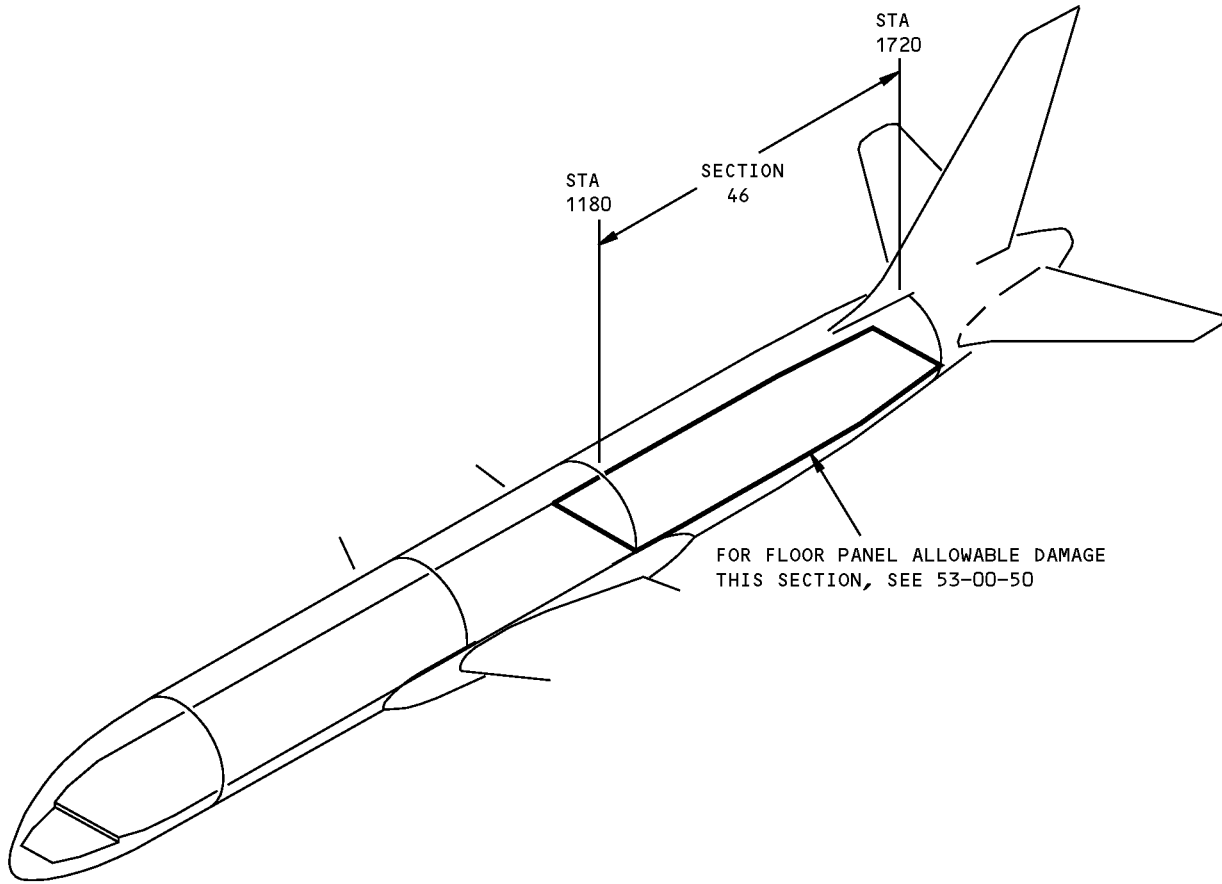
IDENTIFICATION GENERAL - SECTION 46 - MAIN DECK FLOOR PANELS



Section 46 Main Deck Floor Panel Identification
Figure 1

**757-200
STRUCTURAL REPAIR MANUAL**

ALLOWABLE DAMAGE GENERAL - SECTION 46 - MAIN DECK FLOOR PANELS

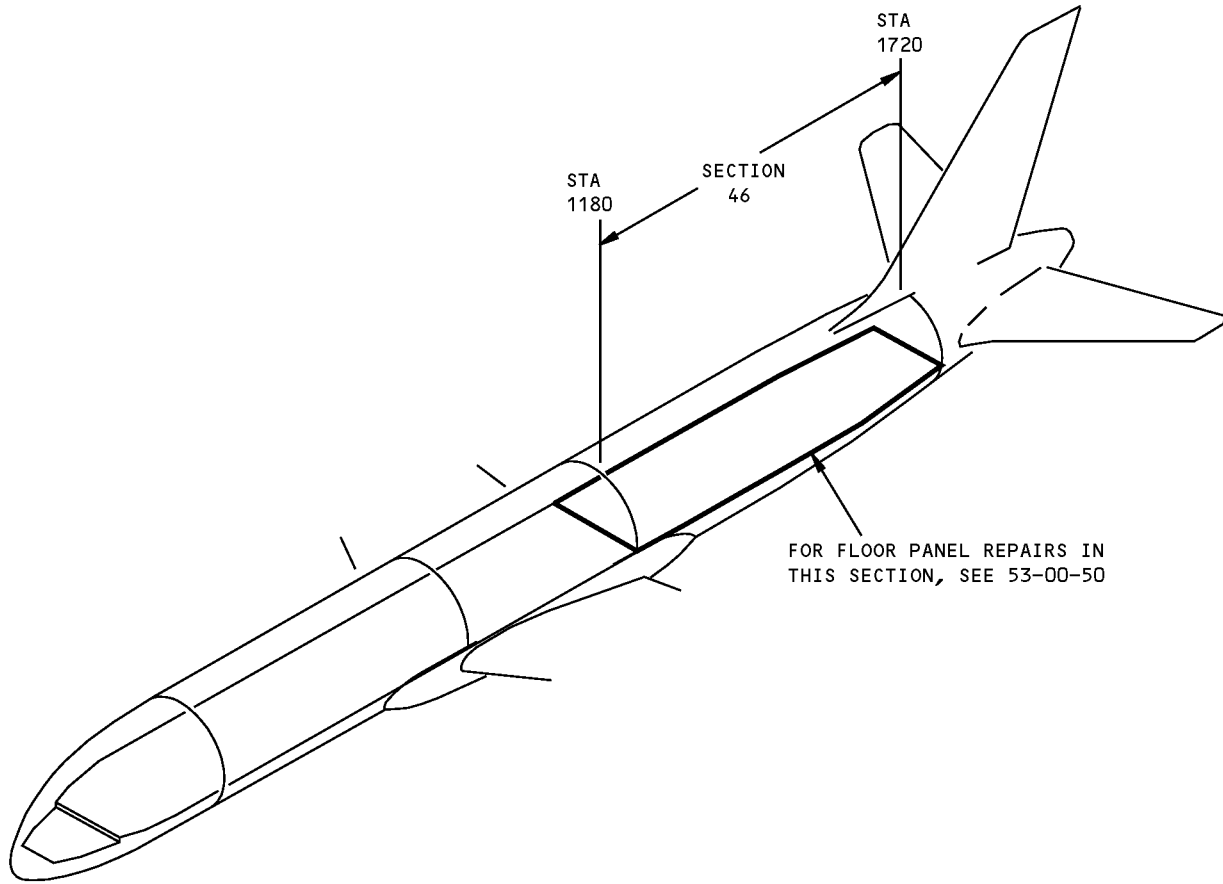


**Section 46 Main Deck Floor Panels Allowable Damage
Figure 101**

D634N201

757-200
STRUCTURAL REPAIR MANUAL

REPAIR GENERAL - SECTION 46 - MAIN DECK FLOOR PANELS



Section 46 Main Deck Floor Panel Repairs
Figure 201

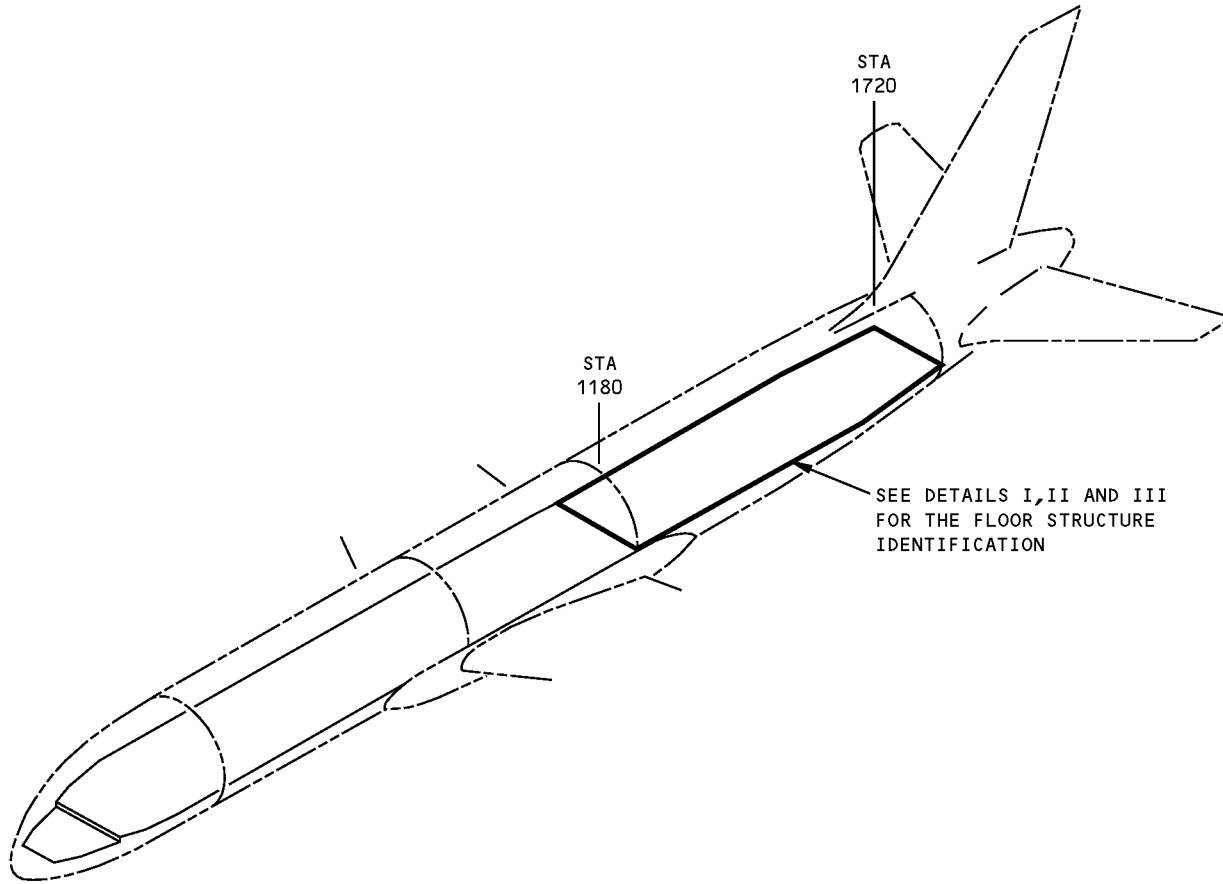
D634N201

53-60-50

REPAIR GENERAL
Page 201
Jan 20/2005

**757-200
STRUCTURAL REPAIR MANUAL**

IDENTIFICATION 1 - SECTION 46 - FLOOR STRUCTURE



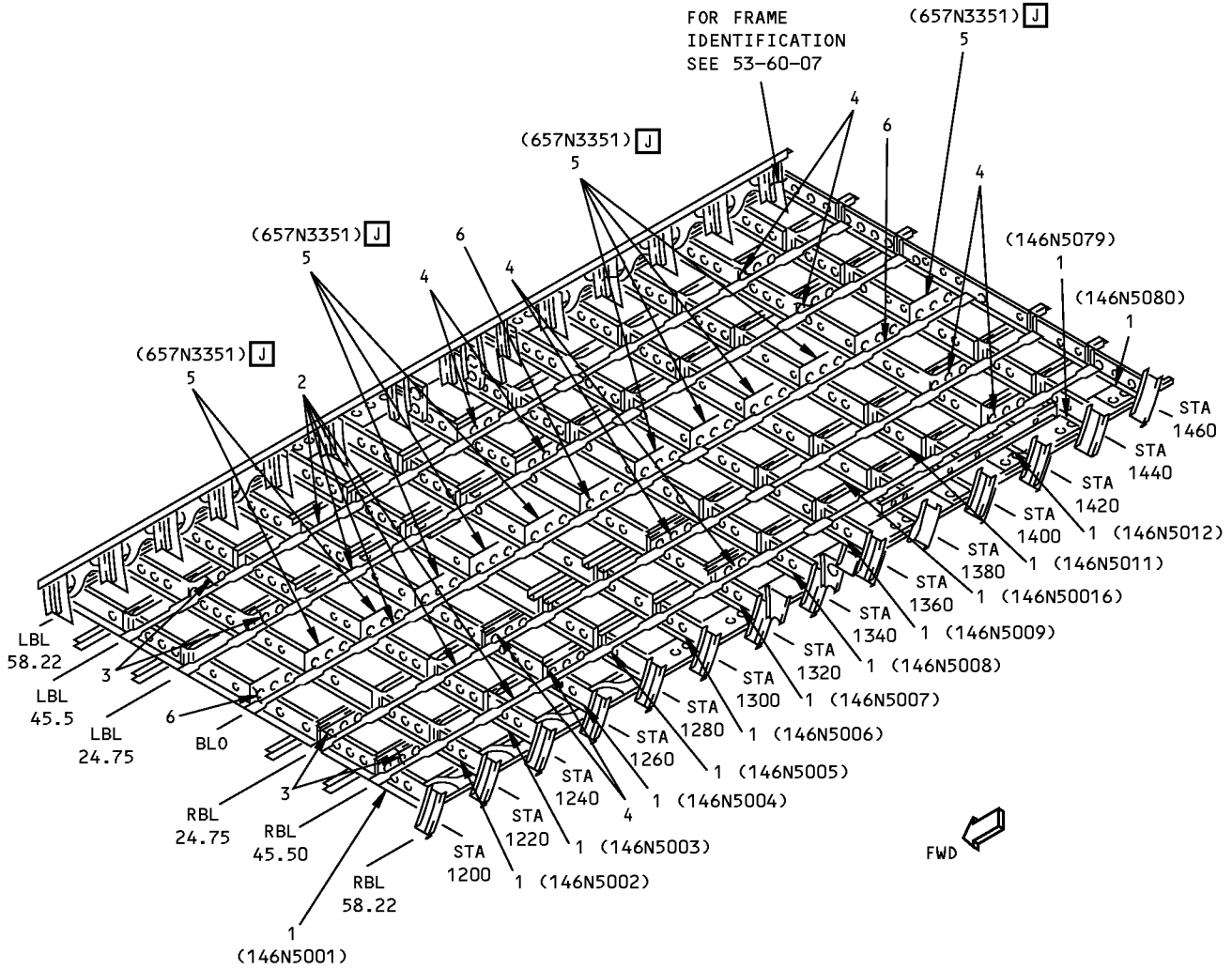
NOTES

- | | |
|---|---|
| <p>A FOR CUM LINE NUMBERS:
9, 10, 11, 13, 14, 16, 23, 25, 28, 30, 31, 33, 34, 36,
37, 38, 80, 82, 85 (BOEING REF: NA220-NA339,
NA403-NA450)</p> <p>B FOR CUM LINE NUMBERS:
12, 17, 24, 26</p> <p>C ALL AIRPLANES EXCEPT FOR A AND B</p> <p>D FOR CUM LINE NUMBERS:
2 THRU 8, 12, 17, 24, 26, 27, 29, 32, 39, 41, 42,
43, 50, 51, 53, 54, 55, 59, 61, 62, 66 (BOEING
REF: NAO29-NA199)</p> <p>E FOR CUM LINE NUMBERS:
9, 10, 11, 13, 14, 16, 23, 25, 28, 30, 31, 33, 34, 36,
37, 38, 80, 82, 85 (BOEING REF: NA220-NA399)</p> | <p>F FOR CUM LINE NUMBERS:
6 THRU 8, 12, 17, 24, 26, 27, 29, 32, 39, 41, 42, 43,
50, 51, 53, 54, 55, 59, 61, 62, 66 (BOEING REF:
NAO29-NA199)</p> <p>G SEE DRAWING 146N5300</p> <p>H CHEM MILLED DEPENDING ON CONFIGURATION.
SEE DRAWING 146N5318</p> <p>I FOR PASSENGER AIRPLANES ONLY</p> <p>J FOR 757-SF AIRPLANES ONLY</p> |
|---|---|

**Section 46 Floor Structure Identification
Figure 1 (Sheet 1 of 7)**

**757-200
STRUCTURAL REPAIR MANUAL**

REFERENCE DRAWINGS
146N5180
J 657N3351



DETAIL I

LIST OF
MATL

**Section 46 Floor Structure Identification
Figure 1 (Sheet 2 of 7)**

IDENTIFICATION 1
Page 2
Sep 20/2006

53-60-51

D634N201



757-200
STRUCTURAL REPAIR MANUAL

ITEM	DESCRIPTION	GAGE	MATERIAL	EFFECTIVITY
1	FLOOR BEAM		BAC1518-338 7075-T6511	
2	STABILIZATION STRAP		BAC1493-577 CLAD 7075-T6	
3	INTERCOSTAL ANGLE WEB LOWER CHORD	0.032 0.032 0.032	CLAD 7075-T6 CLAD 7075-T6 CLAD 7075-T6	
4	INTERCOSTAL ANGLE WEB	0.032 0.025	CLAD 7075-T6 CLAD 7075-T6	
5	INTERCOSTAL WEB LOWER CHORD	0.045	CLAD 7075-T6 BAC1506-1706 7075-T6511	J
6	INTERCOSTAL ANGLE WEB	0.046 0.032	CLAD 7075-T6 CLAD 7075-T6	

LIST OF MATERIALS FOR DETAIL I

Section 46 Floor Structure Identification
Figure 1 (Sheet 3 of 7)

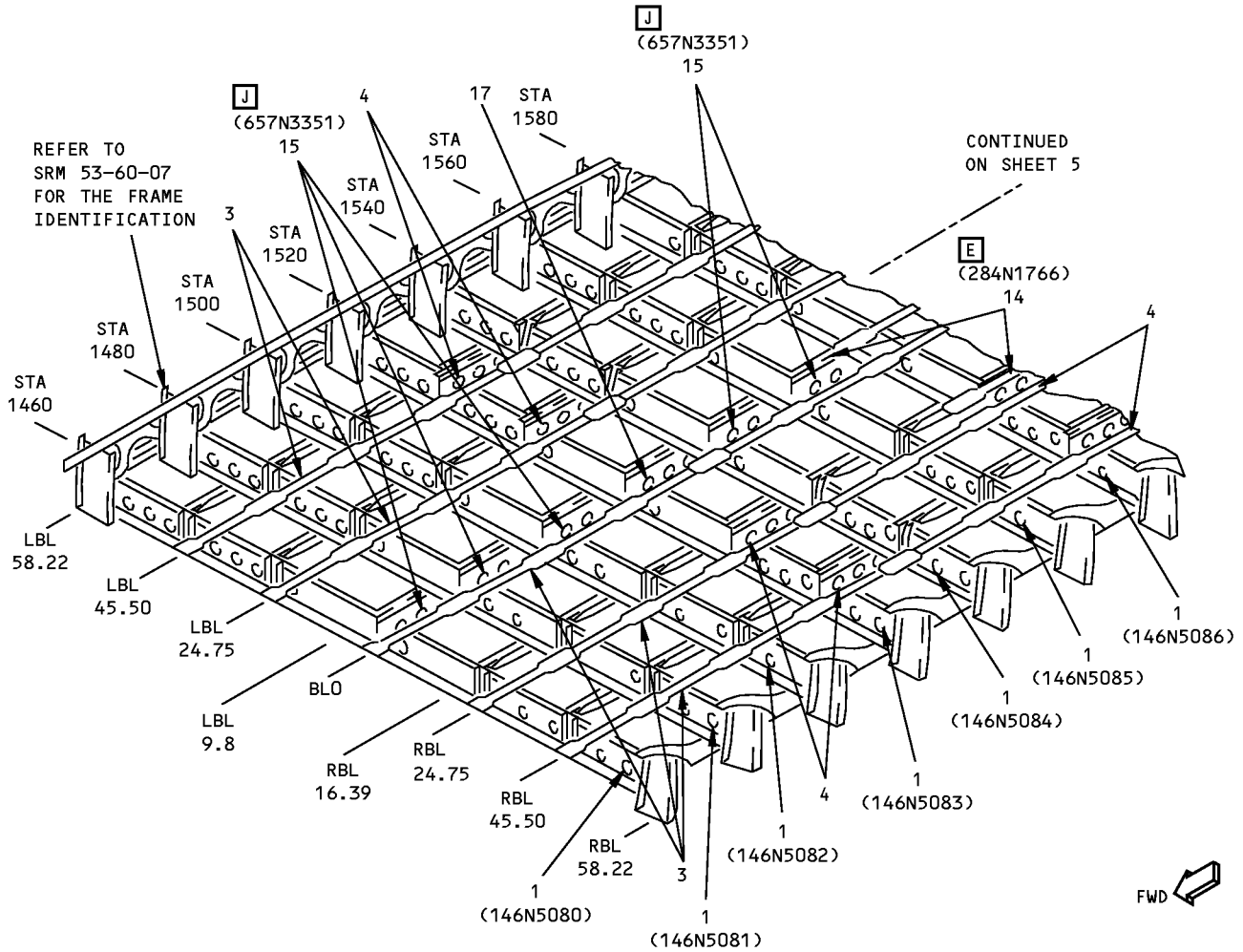
D634N201

53-60-51

IDENTIFICATION 1
Page 3
Sep 20/2006

**757-200
STRUCTURAL REPAIR MANUAL**

REFERENCE DRAWING
146N5180
J 657N0083



DETAIL II



**Section 46 Floor Structure Identification
Figure 1 (Sheet 4 of 7)**

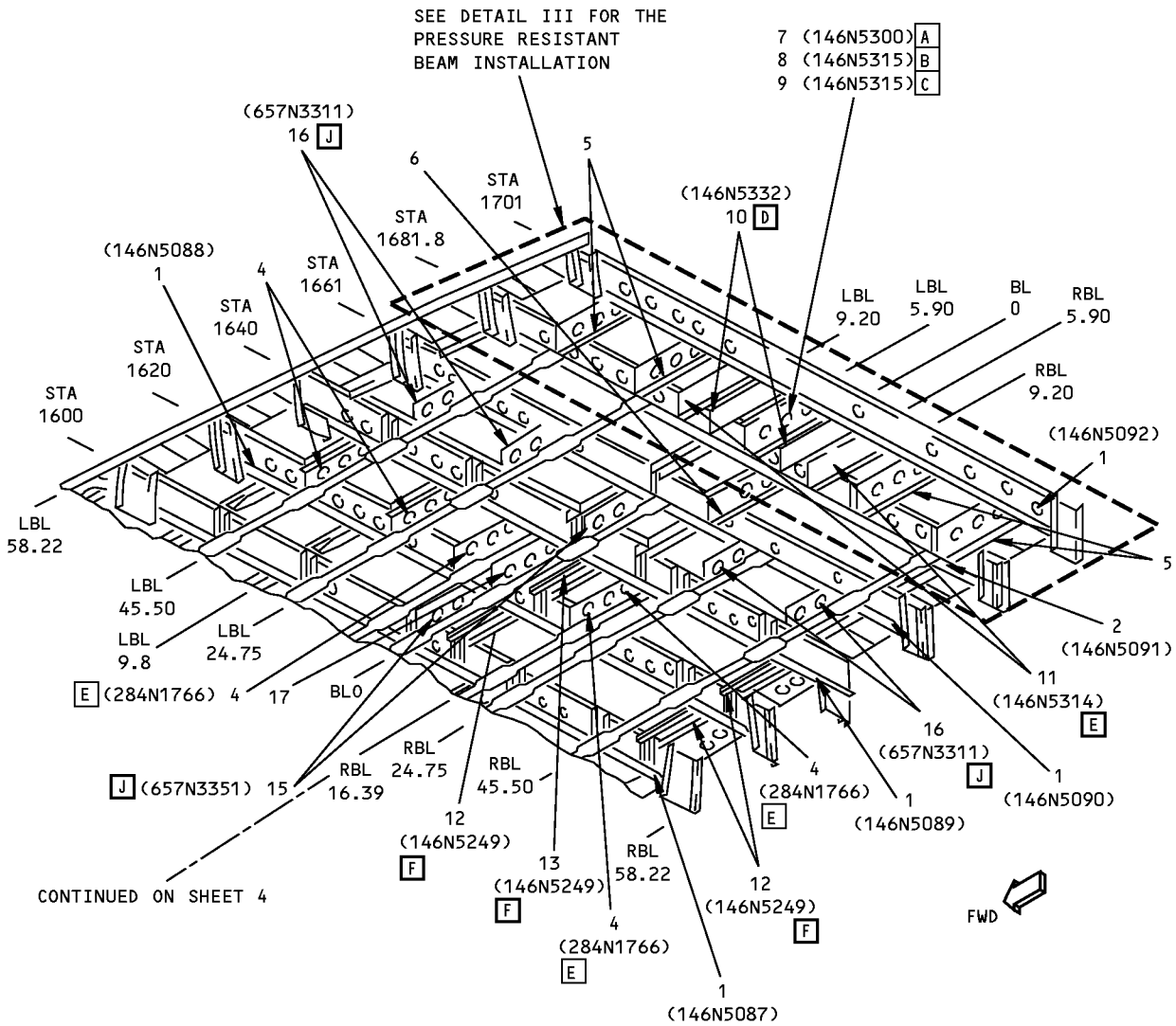
IDENTIFICATION 1
Page 4
Sep 20/2006

53-60-51

D634N201

**757-200
STRUCTURAL REPAIR MANUAL**

REFERENCE DRAWING
146N5180
J 657N0083



LIST OF MATL →

DETAIL II

**Section 46 Floor Structure Identification
Figure 1 (Sheet 5 of 7)**

IDENTIFICATION 1
Page 5
Sep 20/2006

53-60-51

D634N201



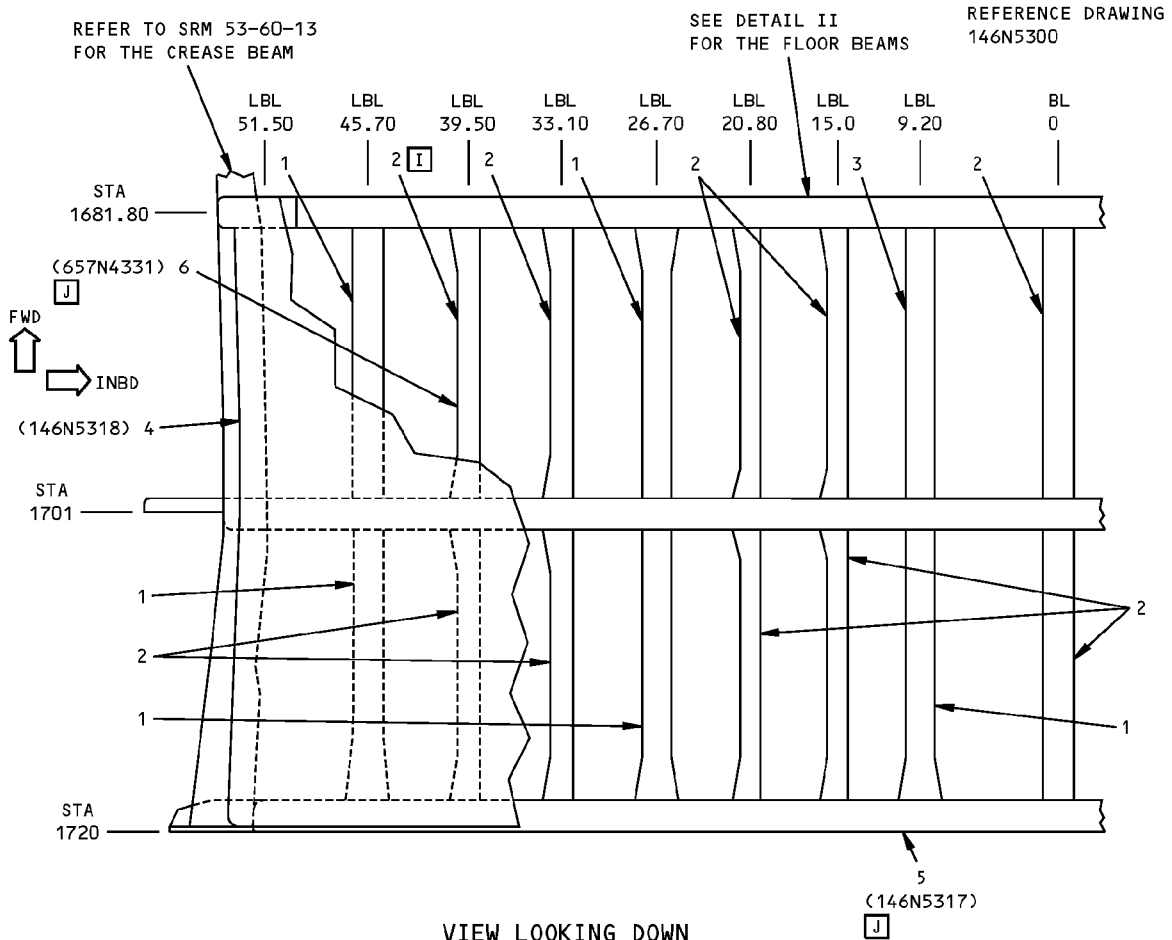
**757-200
STRUCTURAL REPAIR MANUAL**

ITEM	DESCRIPTION	GAGE	MATERIAL	EFFECTIVITY
1	FLOOR BEAM		BAC1518-338 7075-T6511	
2	FLOOR BEAM		BAC1518-827 7075-T6511	
3	STABILIZATION STRAP		BAC1493-577 CLAD 7075-T6	
4	INTERCOSTAL ANGLE WEB	0.032 0.025	CLAD 7075-T6 CLAD 7075-T6	
5	INTERCOSTAL UPPER CHORD WEB LOWER CHORD	 0.032 0.032	BAC1505-101243 7075-T73 OPTIONAL: 7075-T7351 CLAD 7075-T6 CLAD 7075-T6	
6	INTERCOSTAL UPPER CHORD WEB LOWER CHORD	0.04 0.032 0.04	CLAD 7075-T6 CLAD 7075-T6 CLAD 7075-T6	
7	BEAM ASSY SUPPORT FITTING WEB LOWER CHORD	 0.025 0.032	 BAC1508-240 7075-T73511 CLAD 7075-T6 CLAD 7075-T6	A
8	BEAM ASSY FLOOR STIFFENER WEB LOWER CHORD	 0.025 0.032	 AND10136-2001 7075-T73511 CLAD 7075-T6 CLAD 7075-T6	B
9	STIFFENER		AND10136-2001 7075-T73511	C
10	GALLEY FITTING SUPPORT		BAC1508-240 7075-T73511	D
11	SUPPORT PIN BEAM		BAC1505-101243 7075-T73 OPTIONAL: 7075-T7351 BAR BAC1505-101243 7075-T73511	E
12	GALLEY FITTING INTERCOSTAL	0.071	7075-T6	F
13	GALLEY FITTING INTERCOSTAL	0.090	7075-T6	F
14	CHANNEL		AND10137-1603 7075-T73511	
15	INTERCOSTAL WEB LOWER CHORD	0.045	CLAD 7075-T6 BAC1506-1706	J
16	INTERCOSTAL WEB	0.071	CLAD 7075-T6	J
17	INTERCOSTAL ANGLE WEB	0.040 0.025	CLAD 7075-T6 CLAD 7075-T6	

LIST OF MATERIALS FOR DETAIL II

**Section 46 Floor Structure Identification
Figure 1 (Sheet 6 of 7)**

**757-200
STRUCTURAL REPAIR MANUAL**



VIEW LOOKING DOWN
LEFT SIDE IS SHOWN, RIGHT SIDE IS OPPOSITE

DETAIL III

ITEM	DESCRIPTION	GAGE	MATERIAL	EFFECTIVITY
1	PIN BEAM		BAC1505-101243 7075-T73511	
2	TEE		AND10136-2001 7075-T73511	
3	INTERCOSTAL WEB TEE	0.063	7075-T6 CLAD BAC1505-100527 7075-T6511	
4	DECK PLATE	0.071 0.150 0.071	2024-T3 CLAD (H) 2024-T3 CLAD (CHEM MILLED) 2024-T3 CLAD	VARIABLE (G) VARIABLE (G) (J) (J) (J)
5	CHORD - CHANNEL		BAC1509-100487 2024-T3511	
6	SUPPORT		BAC1508-237 7075-T3511	

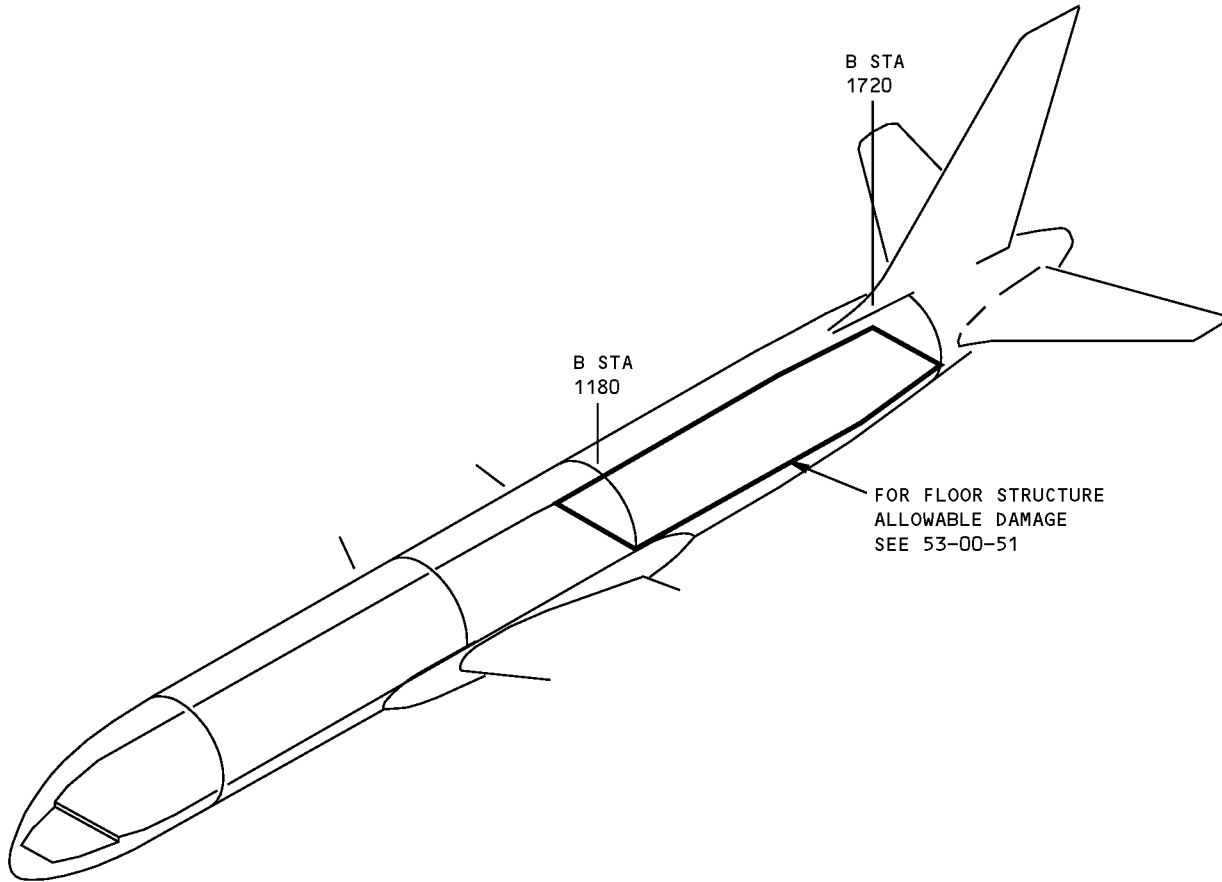
LIST OF MATERIALS FOR DETAIL III

**Section 46 Floor Structure Identification
Figure 1 (Sheet 7 of 7)**



757-200
STRUCTURAL REPAIR MANUAL

ALLOWABLE DAMAGE GENERAL - SECTION 46 - FLOOR STRUCTURE



Section 46 Floor Structure Allowable Damage
Figure 101

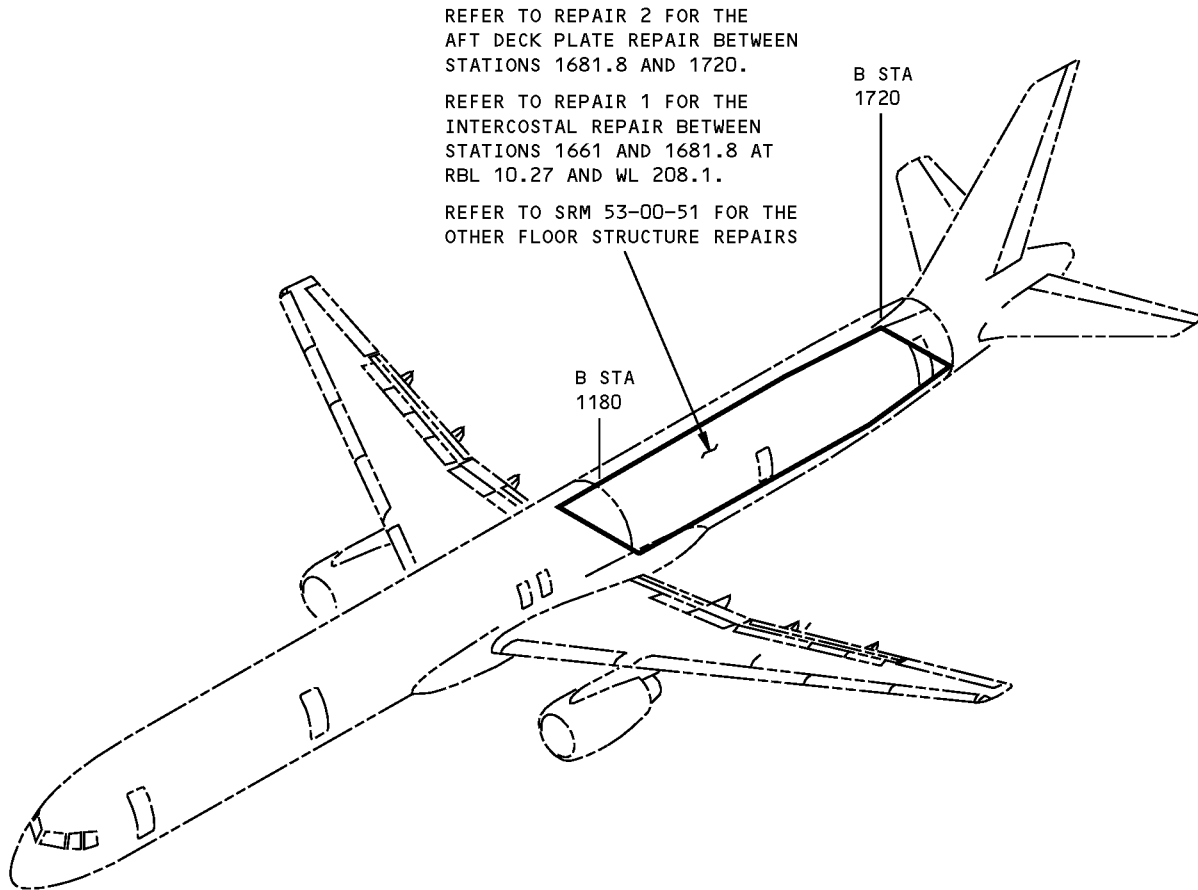
D634N201

ALLOWABLE DAMAGE GENERAL
53-60-51
Page 101
Jan 20/2005



757-200
STRUCTURAL REPAIR MANUAL

REPAIR GENERAL - SECTION 46 - MAIN DECK FLOOR STRUCTURE



Section 46 Main Deck Floor Structure Repairs
Figure 201

D634N201

53-60-51

REPAIR GENERAL
Page 201
Sep 20/2005

STRUCTURAL REPAIR MANUAL

REPAIR 1 - SECTION 46 - FLOOR STRUCTURE - INTERCOSTAL UPPER CHORD REPAIR BETWEEN STATION 1661 AND 1681.8

APPLICABILITY
THIS REPAIR APPLIES TO DAMAGE TO THE UPPER CHORD OF THE INTERCOSTAL BETWEEN BS 1661 AND BS 1681.8, AT WL 208.1 AND RBL 10.27. REPLACEMENT OF THE UPPER CHORD IS NECESSARY IN THIS REPAIR.

REPAIR INSTRUCTIONS

- Remove the floor panels and other structure to get access to the floor beams, gusset and intercostal angle.
- Remove all the initial fasteners from the repair area. See Detail I.
- Remove and discard the damaged angle.
- Make the repair parts. See Table I.
- Assemble the repair parts and drill the initial fastener hole locations and the repair fastener locations. [A] [B]
- Disassemble the repair parts.
- Remove the nicks, scratches, gouges, burrs and sharp edges from the repair parts and the initial parts.
- Apply a chemical conversion coating to the repair parts and to the bare surfaces of the initial parts. Refer to SRM 51-20-01.
- Apply one layer of BMS 10-11, Type I primer to the repair parts and to the bare surfaces of the initial parts. Refer to SOPM 20-41-02.
- Install the floor panel attachments with BACR15DR3 blind rivets and BACN10JR3CFD nutplates through the repair angle only. Install the rivets wet with BMS 5-95 sealant. [B]
- Install the repair parts with BMS 5-95 sealant between the mating surfaces. Refer to SRM 51-20-05.
- Install the repair fasteners at the initial and repair locations.
- Apply a layer of BMS 10-11, Type II enamel to the repair area. Refer to SOPM 20-41-02.

NOTE: As an option, apply one layer of BMS 10-11, Type I primer.

NOTES

- THIS IS A CATEGORY A REPAIR FOR 757-SF AIRPLANES. THE INSPECTIONS GIVEN IN THE MAINTENANCE PLANNING DATA (MPD) ARE SUFFICIENT TO MAINTAIN THE DAMAGE TOLERANCE OF THE INITIAL STRUCTURE WITH THIS REPAIR INSTALLED. REFER TO SRM 51-00-06 FOR REPAIR CATEGORIES AND DEFINITIONS.

- ALL DIMENSIONS ARE IN INCHES UNLESS GIVEN DIFFERENTLY.
- D = THE DIAMETER OF THE FASTENER
- WHEN YOU USE THIS REPAIR REFER TO:
 - SOPM 20-41-02 FOR APPLICATION OF FINISHES
 - SRM 51-10-02 FOR INSPECTION AND REMOVAL OF DAMAGE
 - SRM 51-20-01 FOR PROTECTIVE TREATMENT OF METAL
 - SRM 51-20-05 FOR SEALING OF REPAIRS
 - SRM 51-40 FOR FASTENER CODE, REMOVAL AND INSTALLATION, HOLE SIZES AND EDGE MARGINS.

- [A] MAKE SURE THE INITIAL FASTENER HOLE LOCATIONS IN THE REPAIR ANGLE ARE LOCATED BY THE FASTENER HOLES IN THE FLOOR PANEL. MAKE SURE THE REPAIR FASTENER EDGE MARGIN IS A MINIMUM OF 2D AND FASTENER SPACING IS A MAXIMUM OF 2.0 INCHES (50 mm).
- [B] DRILL THE FASTENER HOLES FOR THE BACR15DR3 RIVETS THROUGH THE REPAIR ANGLE ONLY.
- [C] IF NECESSARY, INSTALL A 1/32 INCH OVERSIZE FASTENER OF THE SAME TYPE AS THE INITIAL FASTENER.

FASTENER SYMBOLS

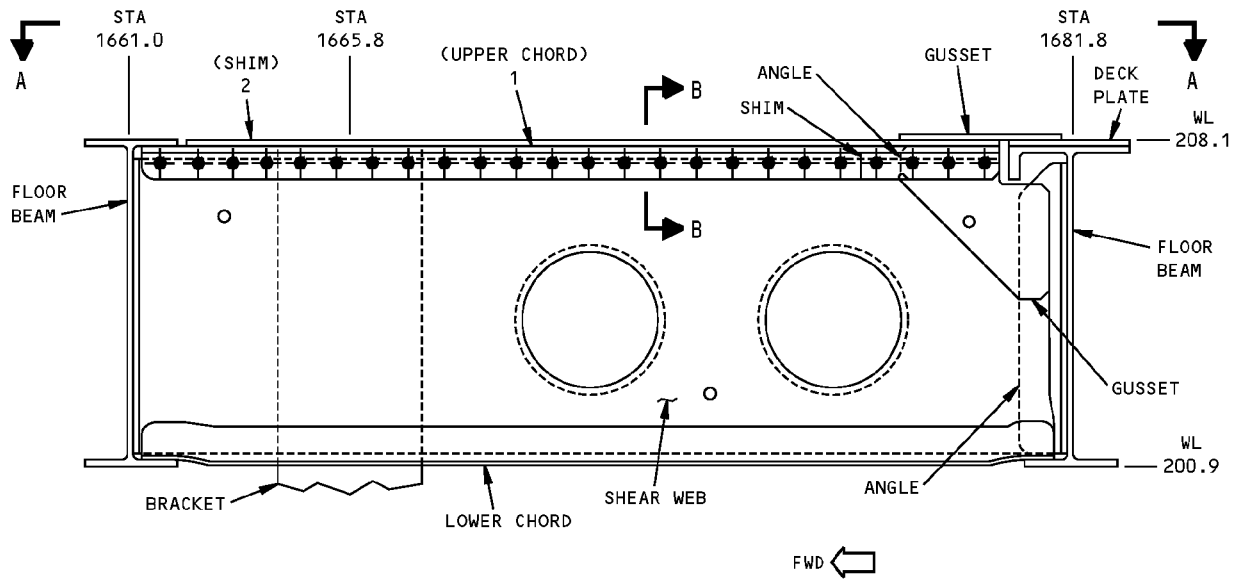
- REFERENCE FASTENER LOCATION
- INITIAL FASTENER LOCATION. INSTALL BACR15FT5D RIVETS. [C]
- INITIAL FASTENER LOCATION. INSTALL BACR15CE5D RIVETS.
- REPAIR FASTENER LOCATION. INSTALL BACR15CE5D RIVETS.
- INITIAL FASTENER LOCATION. INSTALL A BACN10JR3CFD NUTPLATE WITH TWO BACR15DR3 RIVETS. [B]

REPAIR MATERIAL			
	PART	QTY	MATERIAL
1	ANGLE	1	USE THE SAME MATERIAL, HEAT TREAT, DIMENSIONS AND GAGE AS THE INITIAL ANGLE.
2	SHIM	AS REQ'D	7075-T6 (THICKNESS AS REQUIRED)

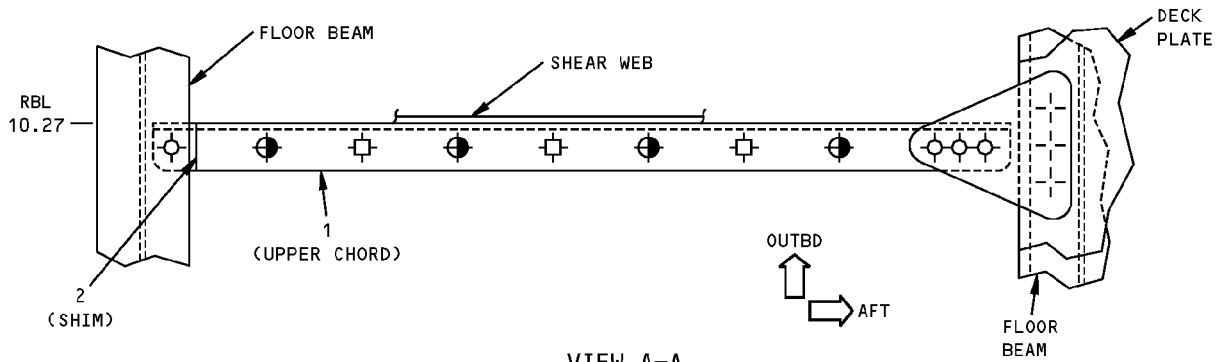
TABLE I

**Section 46 Floor Structure - Intercostal Upper Chord Repair Between Station 1661 and 1681.8
Figure 201 (Sheet 1 of 2)**

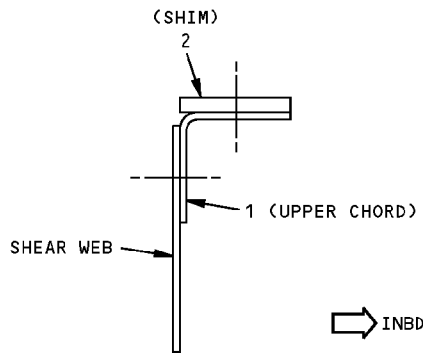
**757-200
STRUCTURAL REPAIR MANUAL**



DETAIL I



VIEW A-A



SECTION B-B

**Section 46 Floor Structure - Intercostal Upper Chord Repair Between Station 1661 and 1681.8
Figure 201 (Sheet 2 of 2)**

STRUCTURAL REPAIR MANUAL

REPAIR 2 - SECTION 46 - AFT DECK PLATE

APPLICABILITY
THIS REPAIR IS APPLICABLE TO THE 146N5318 DECK PLATE LOCATED BETWEEN BS1681.8 TO BS1720. THIS REPAIR IS APPLICABLE TO AIRPLANE DECK PLATES WITHOUT THE DUAL DUCT GALLEY CHILLERS, WITHOUT THE CHEM-MILLED POCKETS AT THE BOTTOM, AND WITHOUT A LAVATORY "R". IF THERE IS CORROSION DAMAGE BELOW THE DECK PLATE ON THE SUPPORT STRUCTURE (INTERCOSTALS, STIFFENERS AND/OR FLOOR BEAMS), REFER TO THE APPROPRIATE SECTION OF THE SRM FOR REPAIR INSTRUCTIONS, OR REPLACE THE DAMAGED STRUCTURE. IF NO REPAIRS ARE AVAILABLE, GET ALTERNATIVE REPAIR INSTRUCTIONS FROM BOEING.

REPAIR INSTRUCTIONS

1. Remove the floor panels and other structure as necessary to get access to the damage. Refer to AMM 53-01-01.
2. Do a thorough visual inspection of the upper and lower surfaces of the deck plate to make sure that all damage is found.
3. Remove all fasteners from the damaged area(s).
4. Remove the damage as given in SRM 51-10-00.
5. After removal of the damage, do an ultrasonic NDT inspection, as given in NDT 51-04-00, Part 1, to measure the remaining thickness of the deck plate. The thickness of the deck plate will determine which of the following procedures to use:
 - A. If after removal of the damage, the remaining thickness in the thinnest location is equal to or greater than 0.063 at fastener locations and 0.060 at locations away from fasteners, refinish the reworked area. Apply a layer of BMS 3-29 corrosion inhibiting compound (CIC) to the repair area to include the upper and lower surfaces of the deck plate, or refer to SRM 51-20-01, Fig. 4 for an alternative CIC application.
 - B. If after removal of the damage, the remaining thickness in the thinnest location is greater than 0.035 but less than 0.063, refer to Alternative I of this repair.
 - C. If after removal of the damage, the remaining thickness in the thinnest location is less than 0.035, refer to Alternative II of this repair.

ALTERNATIVE I (BLENDOUT PLUS THE DOUBLER)

1. Make the repair parts as shown in Table I and Detail I. Where the blendout intersects the fastener locations, and the gaps between the deck plate and the part 1 doubler are more than 0.01 deep, do one of the steps that follow:
 - A. Install the part 2 shim.
 - B. Spotface all the fastener holes in the blendout area a minimum amount to seat filler washers between the deck plate and the part 1 doubler (use a spotface fillet radius of 0.12). Fill the remaining space with BMS 5-95 sealant.
2. Assemble the repair parts and drill the fastener holes. First back drill all the existing fastener holes in the deck plate that are covered by the repair doubler and the shim. Use the same sized and type of fastener as the initial fastener. Drill the field fastener holes in-line with the existing fastener hole pattern. Keep a 4D-6D fastener spacing.
3. Disassemble the repair parts.
4. Remove the nicks, scratches, gouges, burrs and sharp edges from the repair parts and the deck plate. Break all sharp edges to 0.003. Refer to SRM 51-10-00.
5. Apply a chemical conversion coating to the repair parts and to the bare surfaces of the deck plate. Refer to SRM 51-20-01.
6. Apply two layers of BMS 10-11, Type 1 primer to the repair parts and the bare surfaces of the deck plate. Refer to SOPM 20-41-02.
7. Apply 1 layer of BMS 10-11, Type 2 enamel to the repair area. Refer to SOPM 20-41-02.
8. Before you install the repair parts, install repair washers in the initial countersinks of the initial fastener holes of the deck plate. Refer to SRM 51-40-08, Fig. 3.
9. Install the repair parts with BMS 5-95 sealant between the mating surfaces.
10. Install the fasteners. With the exception of the floor panel screws, install all non-aluminum fasteners wet with BMS 5-95 sealant.
11. Remove the excess sealant around the part 1 doubler edges and fastener heads.

**Section 46 Aft Deck Plate Repair
Figure 201 (Sheet 1 of 5)**

STRUCTURAL REPAIR MANUAL**ALTERNATIVE I (BLENDOUT PLUS THE DOUBLER) (CONTINUED)**

12. Apply a layer of BMS 3-29 corrosion inhibiting compound (CIC) to the repair area to include the upper and lower surfaces of the deck plate, or refer to SRM 51-20-01, Fig. 4 for an alternative CIC application.
13. Before you install the floor panels, apply MIL-C-11796 Class 3 corrosion preventive compound to the fastener holes through the structure which are used for floor panel attachment. Refer to SRM 51-20-01, Fig. 4.
14. Install the floor panels. Refer to AMM 53-01-01.

ALTERNATIVE II (CUTOUT PLUS THE DOUBLER)

CAUTION: BEFORE YOU CUT OUT THE SECTION OF CORRODED DECK PLATE, BE CAREFUL NOT TO DAMAGE STRUCTURE UNDERNEATH THE DECK PLATE.

1. Put a thin steel plate or equivalent between the deck plate and the support structure (stiffeners, floor beams, intercostals) before you cut the damaged section of the deck plate.
2. Cut away the corrosion damaged section.
3. Make the repair parts as given in Table II and Detail I.
4. Assemble the repair parts and drill the fastener holes. First back drill all the existing fastener holes in the deck plate that are covered by the repair doubler and the filler. Use the same size and type of fastener as the initial fastener. Drill the field fastener holes in-line with the existing fastener hole pattern. Keep a 4D-6D fastener spacing.
5. Disassemble the repair parts.
6. Remove the nicks, scratches, gouges, burrs and sharp edges from the repair parts and the deck plate. Break all sharp edges to 0.003 inch (0.076 mm). Refer to SRM 51-10-02.
7. Apply a chemical conversion coating to the repair parts and the bare surfaces of the deck plate. Refer to SRM 51-20-01.
8. Apply two layers of BMS 10-11, Type 1 primer to the repair parts and the bare surfaces of the deck plate cutout.
9. Apply one layer of BMS 10-11, Type 2 enamel to the repair area (deck plate cutout) and the repair parts. Refer to SOPM 20-41-02.

10. Before you install the repair parts, install repair washers in the initial deck plate countersinks where the fastener holes go through the repair doubler. Refer to SRM 51-40-08, Fig. 3.
11. Install the repair parts with BMS 5-95 sealant on all the mating surfaces.
12. With the exception of the floor panel screws, install all non-aluminum fasteners wet with BMS 5-95 sealant.
13. Remove the excess sealant around the part 2 doubler edges and the fastener heads.
14. Apply a layer of BMS 3-29 corrosion inhibiting compound (CIC) to the repair area to include the upper and lower surfaces of the deck plate, or refer to SRM 51-20-01 for an alternative CIC application.
15. Before you install the floor panels, apply MIL-C-11796 Class 3 corrosion preventive compound to the fastener holes through the structure which are used for floor panel attachment. Refer to SRM 51-20-01, Fig. 4.
16. Install the floor panels. Refer to AMM 53-01-01.

NOTES

- ALL DIMENSIONS IN THIS REPAIR ARE GIVEN IN INCHES.
- USE THE SAME DIAMETER AND TYPE OF FASTENERS AT THE INITIAL LOCATIONS. USE BACR15CE6D AT ALL NEW REPAIR LOCATIONS.
- D = FASTENER DIAMETER
- WHEN YOU USE THIS REPAIR REFER TO:
 - AMM 53-01-01 FOR REMOVAL AND INSTALLATION OF THE FLOOR PANEL
 - NDT 51-04-00 FOR ULTRASONIC INSPECTION
 - SOPM 20-41-02 FOR APPLICATION OF FINISHES
 - SRM 51-10-02 FOR INSPECTION AND REMOVAL OF DAMAGE
 - SRM 51-20-01 FOR PROTECTIVE TREATMENT OF METALLIC AND GRAPHITE MATERIALS
 - SRM 51-20-05 FOR REPAIR SEALING
 - SRM 51-40-01 FOR FASTENER CODE, INSTALLATION AND REMOVAL, HOLE SIZES, AND EDGE MARGINS
 - SRM 51-40-08 FOR COUNTERSINKING AND COUNTERSINK WASHERS

**Section 46 Aft Deck Plate Repair
Figure 201 (Sheet 2 of 5)**

**757-200
STRUCTURAL REPAIR MANUAL**

NOTES (CONTINUED)

- A** THERE MUST BE A MINIMUM OF THREE FASTENER ROWS ON ALL 4 SIDES BEYOND THE CUTOUT OR BLENDOUT EXCEPT WHERE IMPOSSIBLE AT THE EDGE OF THE DECK PLATE. FLOOR PANEL FASTENERS DO NOT COUNT AS ANY OF THE 3 ROWS OF FASTENERS.
- B** IT IS REQUIRED THAT THE PART 2 DOUBLER EXTEND TO PICK-UP FASTENERS COMMON TO THE STIFFENERS.
- C** APPLY A BEAD OF BMS 5-95 SEALANT WHERE THE EDGE OF THE DOUBLER MEETS THE DECK PLATE.

FASTENER SYMBOLS

- + INITIAL FASTENER LOCATION. INSTALL THE SAME TYPE AND DIAMETER FASTENER AS THE INITIAL FASTENER (UP TO 1/32-INCH DIAMETER OVERSIZE).
- REPAIR FASTENER LOCATION. INSTALL A BACR15CE6D() RIVET.
- ▲ FLOOR PANEL FASTENER LOCATION. INSTALL THE SAME TYPE AND SIZE FLOOR PANEL FASTENER AND NUTPLATE AS THE ONES REMOVED.

ALTERNATIVE I BLENDOUT REPAIR MATERIAL			
PART		QTY	MATERIAL
1	DOUBLER	1	0.063 2024-T3 CLAD
2	SHIM OR FILLER WASHERS	-	2024-T3 (THICKNESS AND QUANTITY AS REQUIRED)

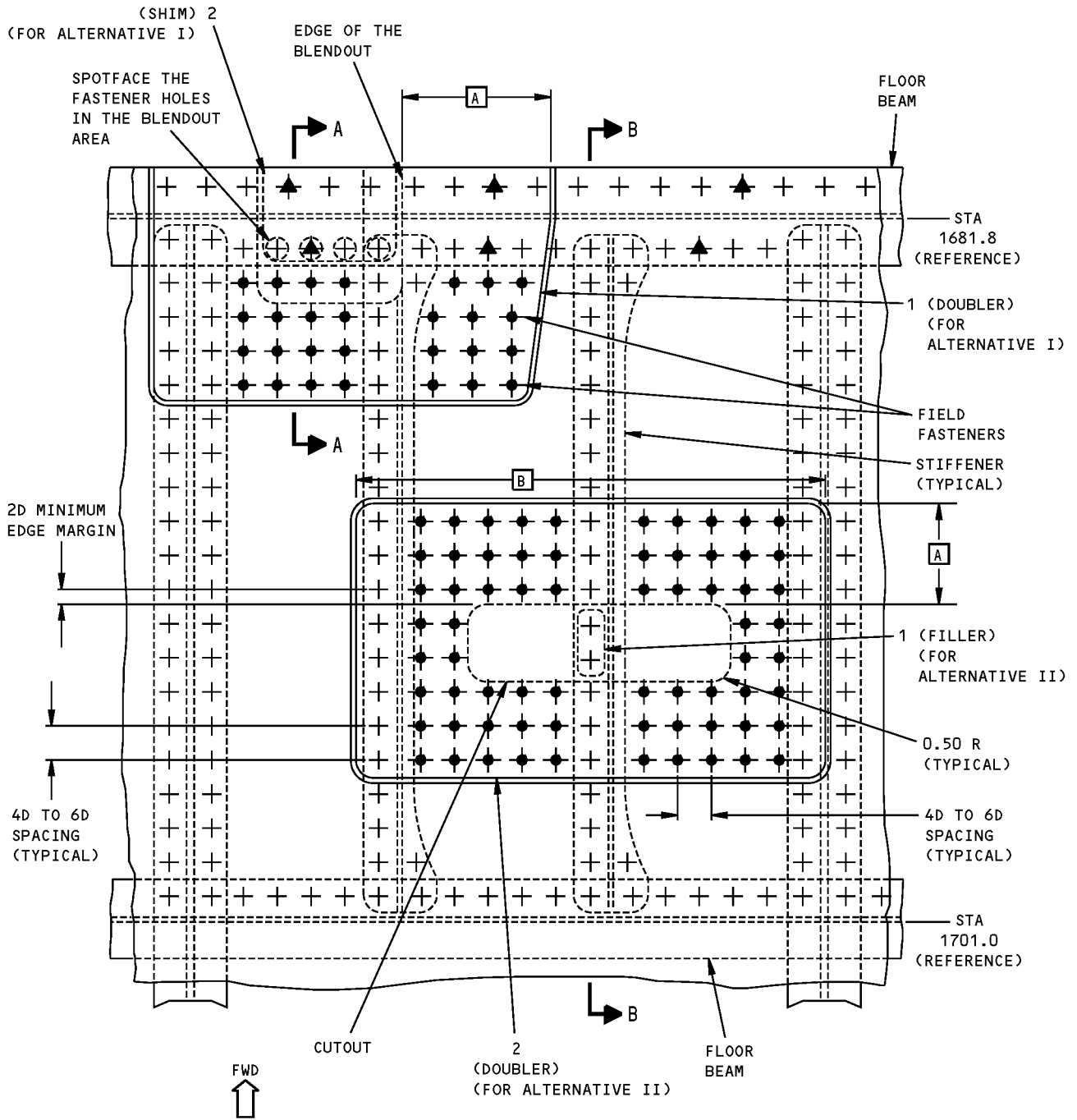
TABLE I

ALTERNATIVE II CUTOUT REPAIR MATERIAL			
PART		QTY	MATERIAL
1	FILLER	1	0.071 2024-T3
2	DOUBLER	1	0.080 2024-T3 CLAD

TABLE II

**Section 46 Aft Deck Plate Repair
Figure 201 (Sheet 3 of 5)**

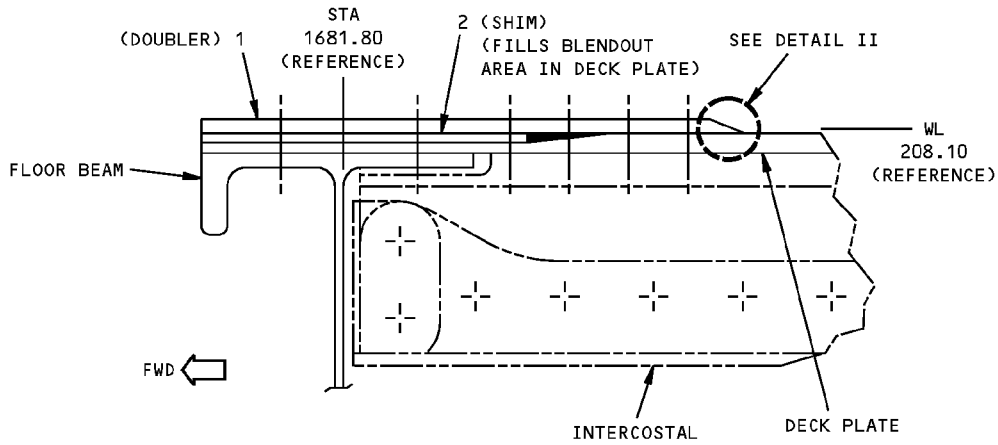
**757-200
STRUCTURAL REPAIR MANUAL**



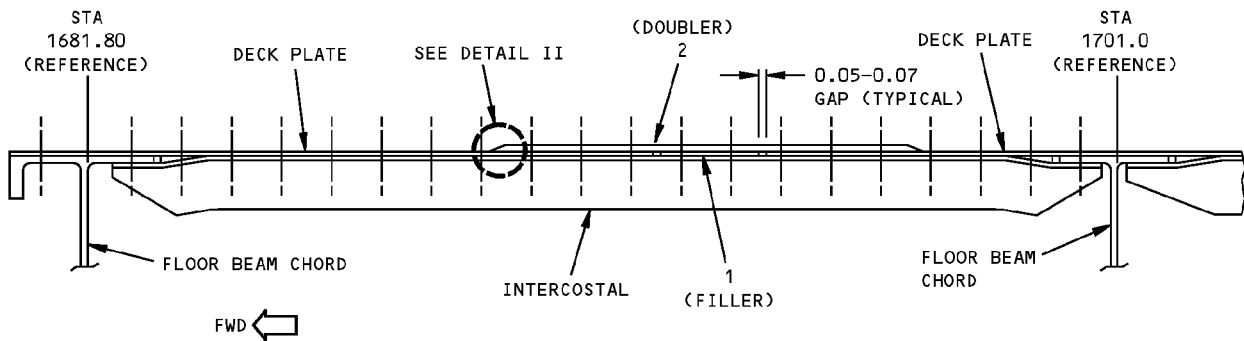
**TYPICAL REPAIR INSTALLATION
DETAIL I**

**Section 46 Aft Deck Plate Repair
Figure 201 (Sheet 4 of 5)**

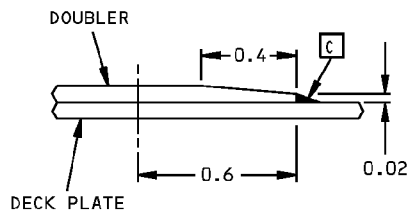
**757-200
STRUCTURAL REPAIR MANUAL**



SECTION A-A



SECTION B-B

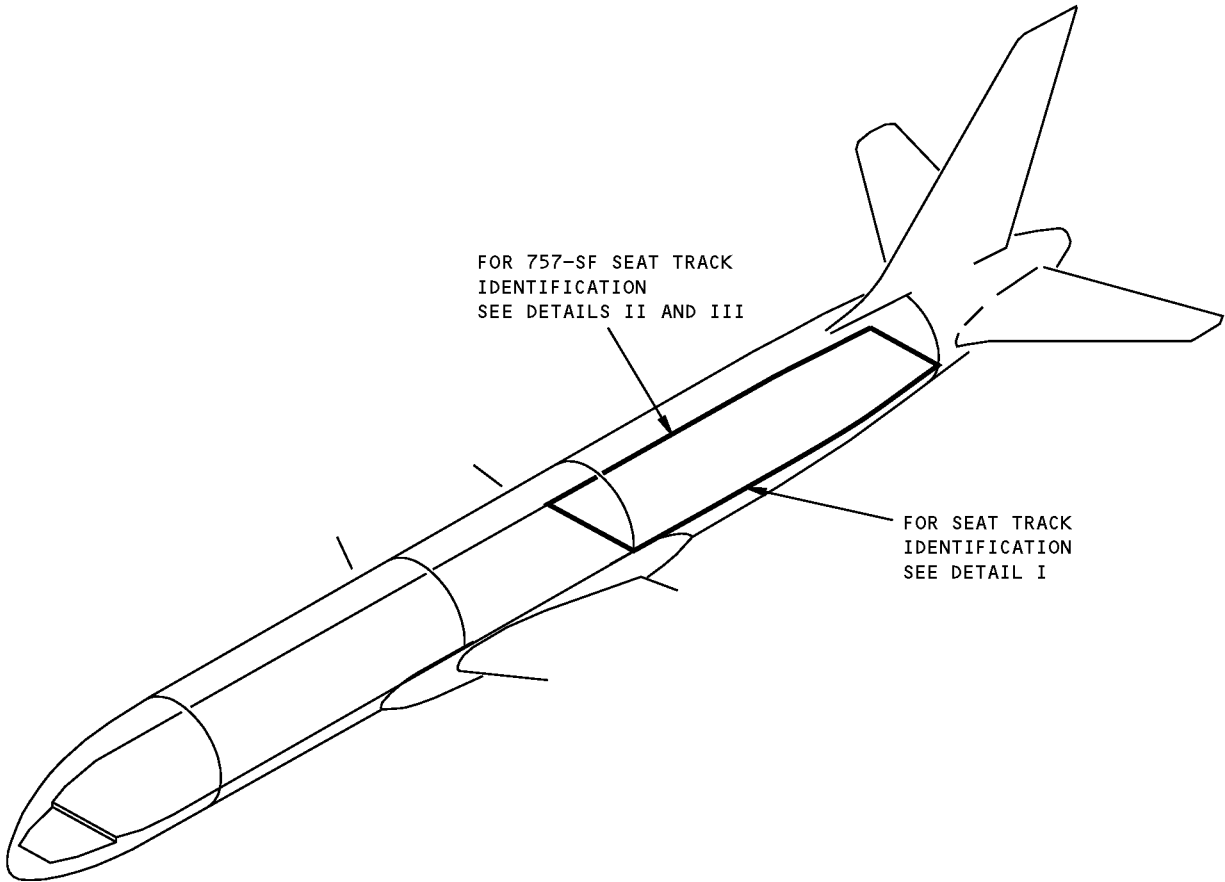


DETAIL II

**Section 46 Aft Deck Plate Repair
Figure 201 (Sheet 5 of 5)**

757-200
STRUCTURAL REPAIR MANUAL

IDENTIFICATION 1 - SECTION 46 - SEAT TRACKS



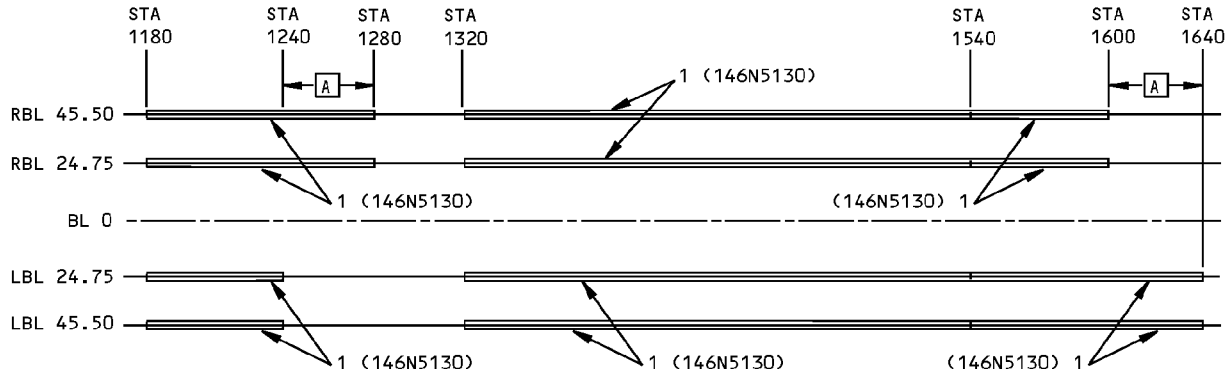
NOTES

- A** BASIC CONFIGURATION VARIES IN THIS AREA AS AN OPERATOR'S OPTION. SEE TABLE I FOR VARIATIONS
- B** BASIC CONFIGURATION VARIES IN THIS AREA AS AN OPERATOR'S OPTION. SEE TABLE II FOR VARIATIONS

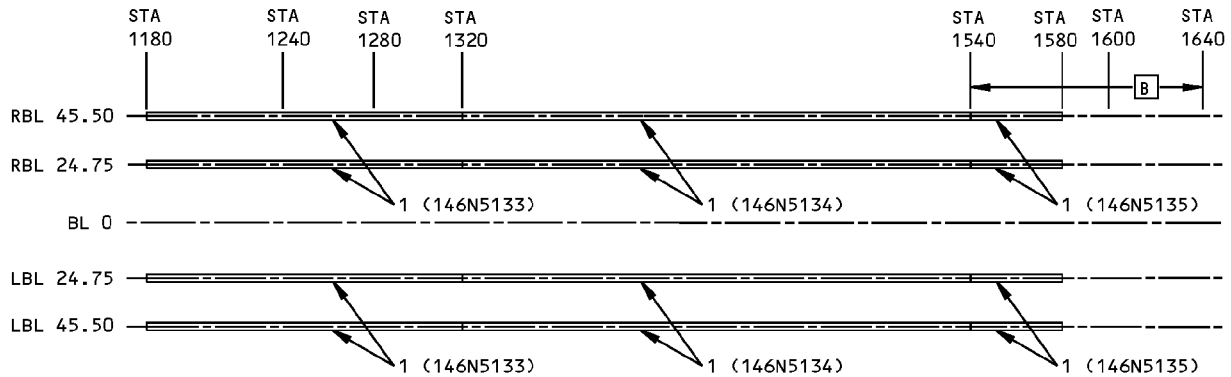
Section 46 Seat Track Identification
Figure 1 (Sheet 1 of 5)

**757-200
STRUCTURAL REPAIR MANUAL**

REF DWG
146N5120



**AIRPLANES WITH NO. 3 EMERGENCY EXIT DOORS
BASIC CONFIGURATION**



**AIRPLANES WITH OVERWING EXITS
BASIC CONFIGURATION**

DETAIL I

ITEM	DESCRIPTION	GAGE	MATERIAL	EFFECTIVITY
1	SEAT TRACK		BAC1520-792 7178-T6511	

LIST OF MATERIALS FOR DETAIL I

**Section 46 Seat Track Identification
Figure 1 (Sheet 2 of 5)**

D634N201

53-60-52

IDENTIFICATION 1
Page 2
Jan 20/2005



**757-200
STRUCTURAL REPAIR MANUAL**

B.L. STA	DWG NO.	FROM STA	TO STA	MATERIAL	OPERATOR CONFIGURATION
RBL 45.50 AND 24.75	146N5130	1540	1640	BAC1520-792 7178-T6511	EAL,BAB,INT
LBL 45.50 AND 24.75	146N5123	1180	1240	BAC1520-792 7178-T6511	BAB,INT,DAL
LBL 45.50 AND 24.75	146N5122	1240	1280	15-5PH CRES	BAB,INT,DAL
RBL 45.50 AND 24.75	146N5125	1540	1600	BAC1520-792 7178-T6511	EAL,LTS
RBL 45.50 AND 24.75	146N5127	1600	1640	15-5PH CRES	EAL,LTS
RBL 45.50 AND 24.75	146N5128	1540	1640	BAC1520-792 7178-T6511	DAL
LBL 45.50 AND 24.75	146N5128	1540	1640	BAC1520-792 7178-T6511	DAL

VARIABLE SEAT TRACKS FOR AIRPLANES WITH NO. 3 EMERGENCY EXIT DOOR
TABLE I

B.L. STA	DWG NO.	FROM STA	TO STA	MATERIAL	OPERATOR CONFIGURATION
RBL 45.50 AND 24.75	146N5137	1540	1600	BAC1520-792 7178-T6511	DAL
LBL 45.50 AND 24.75	146N5137	1540	1600	BAC1520-792 7178-T6511	DAL
RBL 45.50 AND 24.75	146N5146	1320	1540	BAC1520-792 7178-T6511	SIA
LBL 45.50 AND 24.75	146N5146	1320	1540	BAC1520-792 7178-T6511	SIA
RBL 45.50 AND 24.75	146N5147	1540	1560	BAC1520-792 7178-T6511	SIA
LBL 45.50 AND 24.75	146N5147	1540	1560	BAC1520-792 7178-T6511	SIA

VARIABLE SEAT TRACKS FOR AIRPLANES WITH OVERWING EMERGENCY EXITS
TABLE II

**Section 46 Seat Track Identification
Figure 1 (Sheet 3 of 5)**

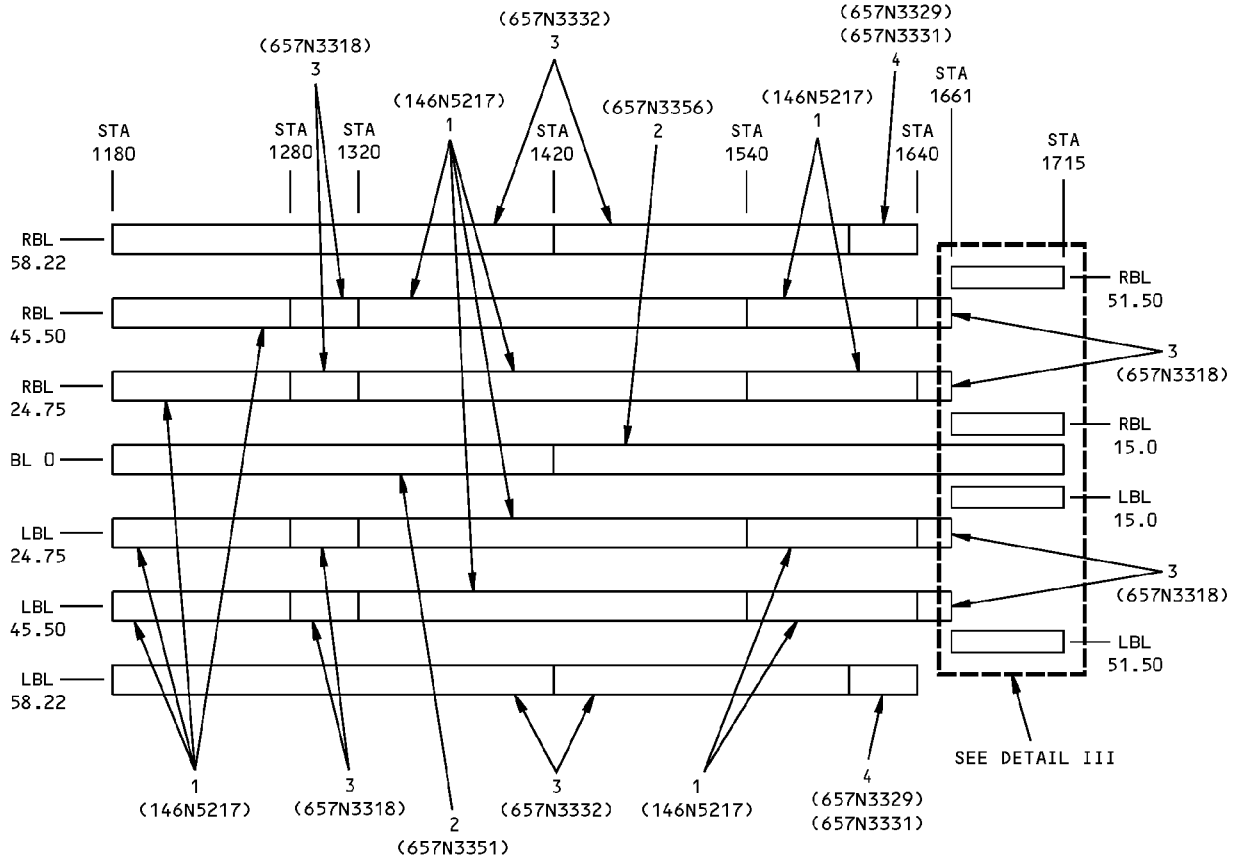
D634N201

53-60-52

IDENTIFICATION 1
Page 3
Jan 20/2005

757-200 STRUCTURAL REPAIR MANUAL

REFERENCE DRAWINGS
146N5016
657N3321
657N3351
657N4331



ITEM	DESCRIPTION	GAGE	MATERIAL	EFFECTIVITY
1	SEAT TRACK		BAC1520-2472 7050-T76511	
2	SEAT TRACK		BAC1520-2474 7050-T76511	
3	SEAT TRACK		BAC1520-792 7178-T6511	
4	SEAT TRACK CROWN SUPPORT		15-5 PH CRES HTTR 180-200 KSI BAC1508-237 7075-T6511	

LIST OF MATERIALS FOR DETAIL II

**Section 46 Seat Track Identification
Figure 1 (Sheet 4 of 5)**

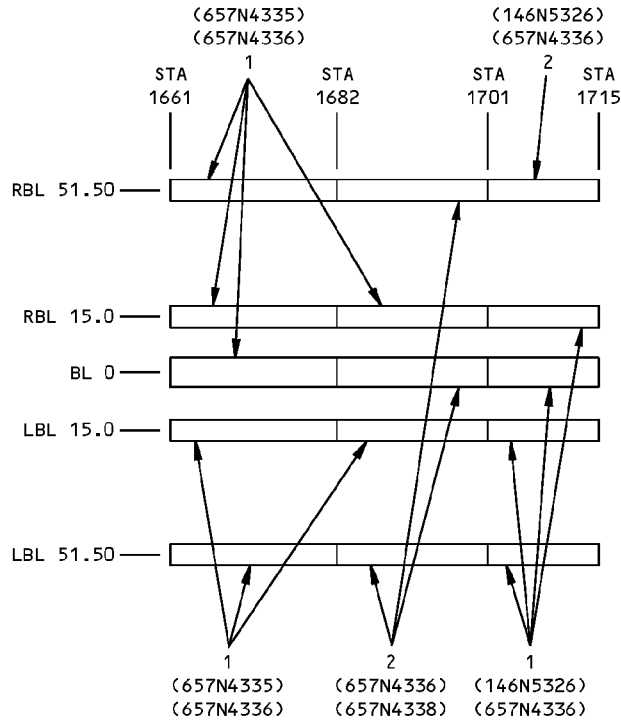
IDENTIFICATION 1
Page 4
Jan 20/2005

53-60-52

D634N201

**757-200
STRUCTURAL REPAIR MANUAL**

REFERENCE DRAWING
657N4331



757-SF AIRPLANES ONLY
DETAIL III

ITEM	DESCRIPTION	GAGE	MATERIAL	EFFECTIVITY
1	SEAT TRACK CROWN SUPPORT		15-5 PH CRES HTTR 180-200 KSI BAC1508-237 7075-T73511	
2	SEAT TRACK CROWN SUPPORT		15-5 PH CRES HTTR 180-200 KSI BAC1508-240 7075-T73511	

LIST OF MATERIALS FOR DETAIL III

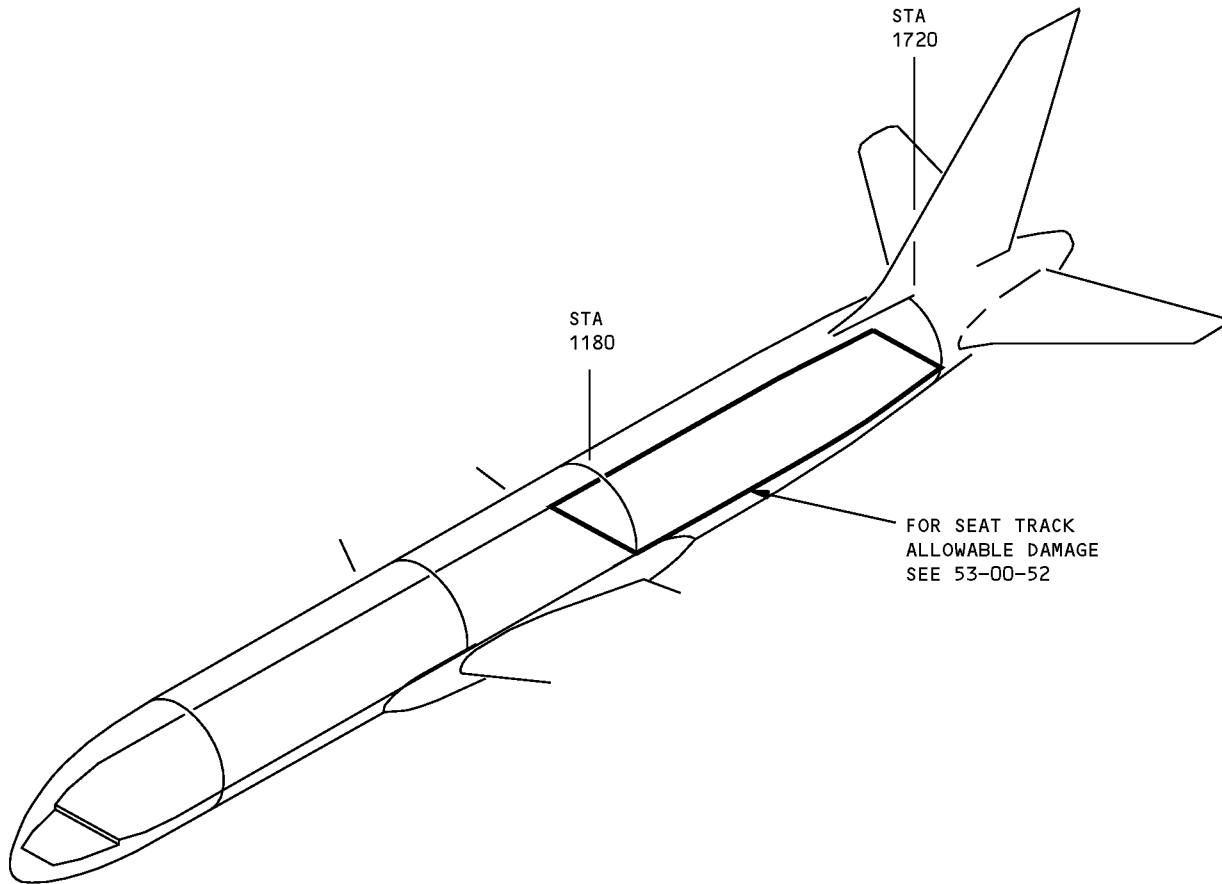
**Section 46 Seat Track Identification
Figure 1 (Sheet 5 of 5)**



757-200
STRUCTURAL REPAIR MANUAL

ALLOWABLE DAMAGE GENERAL - SECTION 46 - SEAT TRACKS

REF DWG
146N5120



Section 46 Seat Track Allowable Damage
Figure 101

D634N201

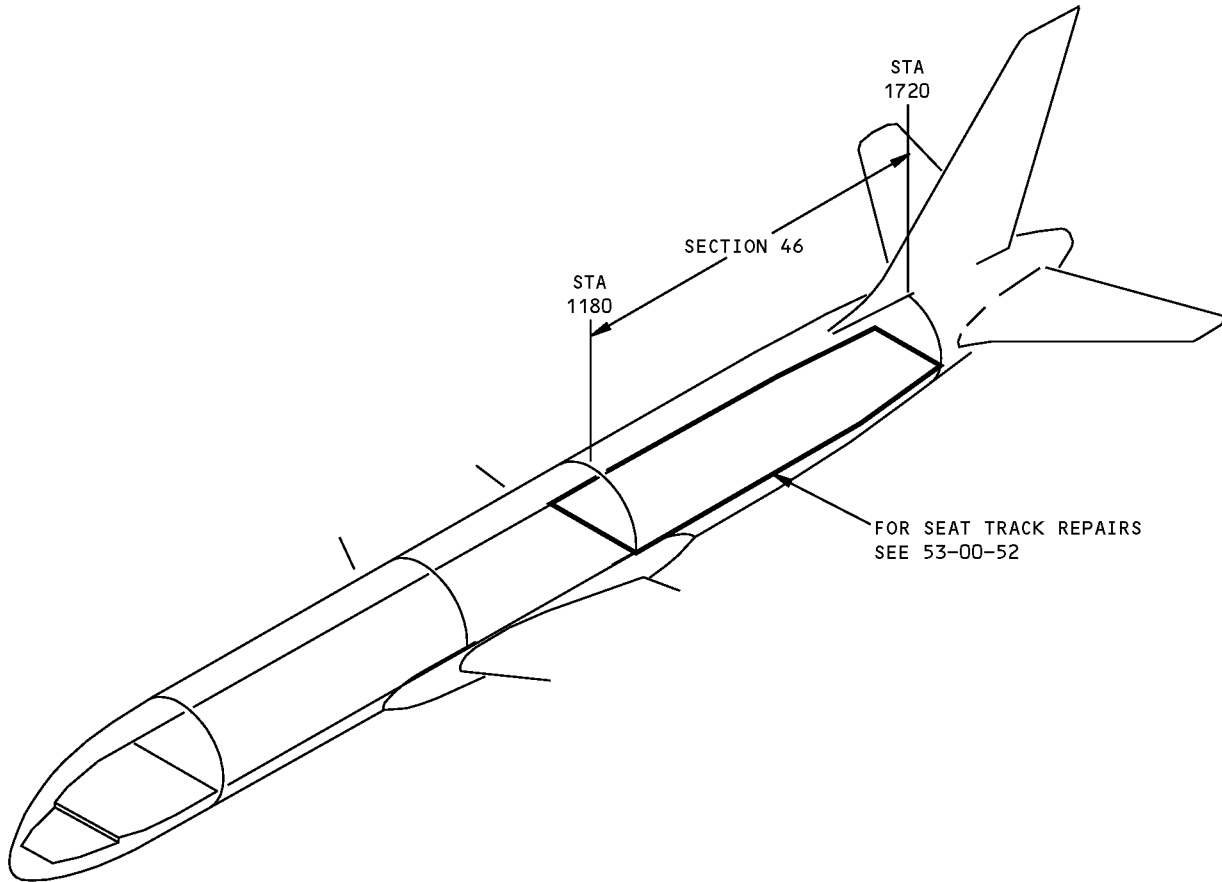
ALLOWABLE DAMAGE GENERAL
53-60-52
Page 101
Jan 20/2005



757-200
STRUCTURAL REPAIR MANUAL

REPAIR GENERAL - SECTION 46 - MAIN DECK SEAT TRACKS

REF DWG
146N5120



Section 46 Main Deck Seat Track Repair
Figure 201

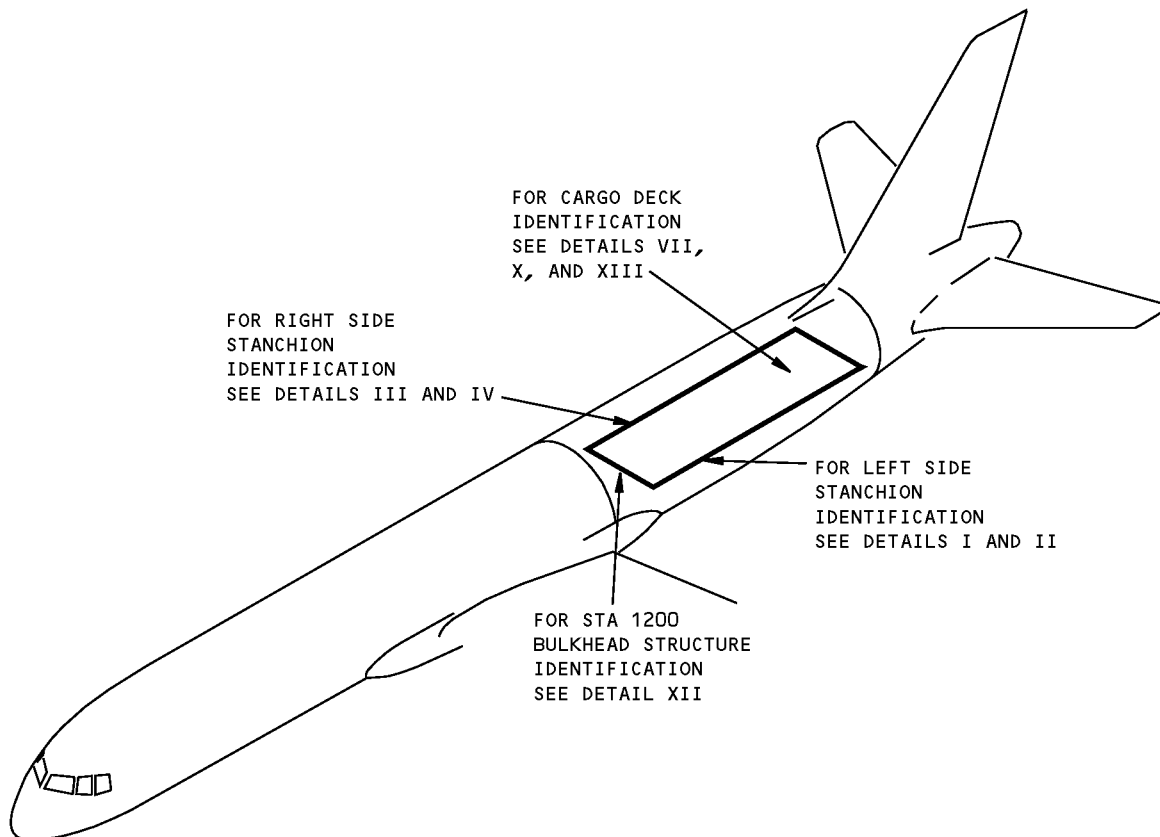
D634N201

53-60-52

REPAIR GENERAL
Page 201
Jan 20/2005

757-200
STRUCTURAL REPAIR MANUAL

IDENTIFICATION 1 - SECTION 46 - CARGO COMPARTMENT STRUCTURE



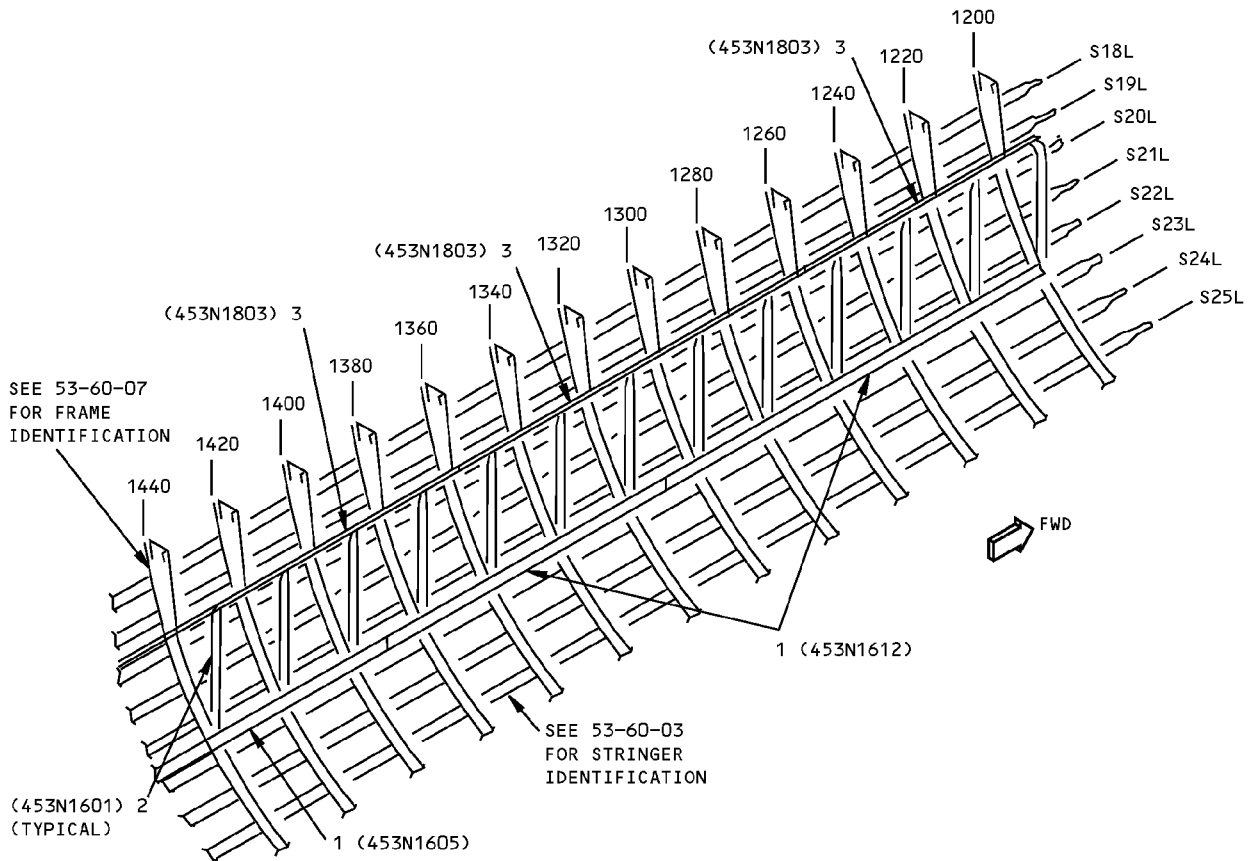
NOTES

- A** FOR AIRPLANES WITH A NO. 3 CARGO DOOR.
- B** OPTIONAL DECK PLATE THICKNESS.

Section 46 Cargo Compartment Structure Identification
Figure 1 (Sheet 1 of 13)

**757-200
STRUCTURAL REPAIR MANUAL**

REF DWG
453N1231



DETAIL I



**Section 46 Cargo Compartment Structure Identification
Figure 1 (Sheet 2 of 13)**

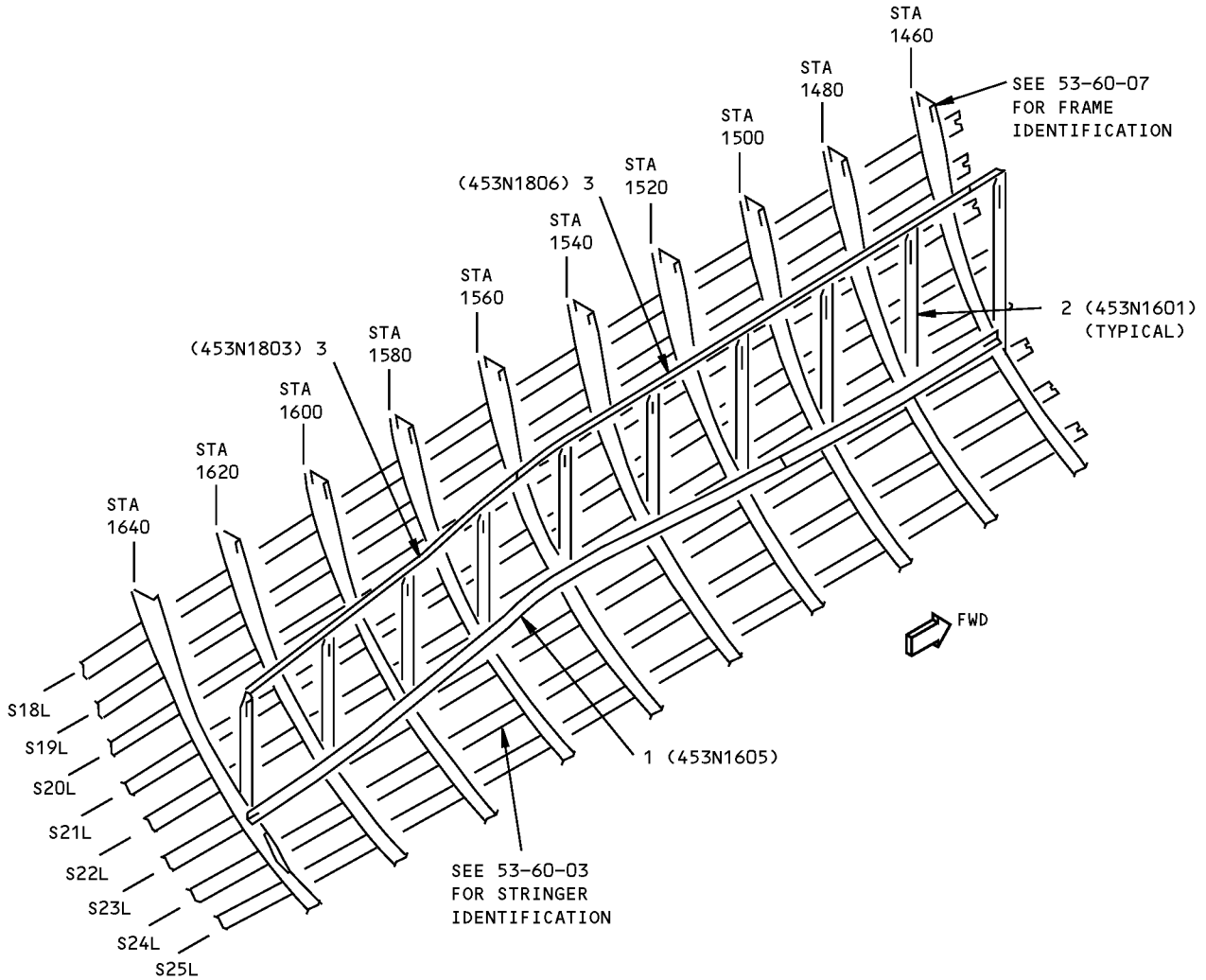
IDENTIFICATION 1
Page 2
Jan 20/2005

53-60-53

D634N201

**757-200
STRUCTURAL REPAIR MANUAL**

REF DWG
453N1231



DETAIL II

ITEM	DESCRIPTION	GAGE	MATERIAL	EFFECTIVITY
1	ANGLE	0.063	CLAD 2024-T3	
2	STANCHION		GRAPHITE/EPOXY LAMINATE	
3	ANGLE	0.063	2024-T42	

LIST OF MATERIALS FOR DETAILS I AND II

**Section 46 Cargo Compartment Structure Identification
Figure 1 (Sheet 3 of 13)**

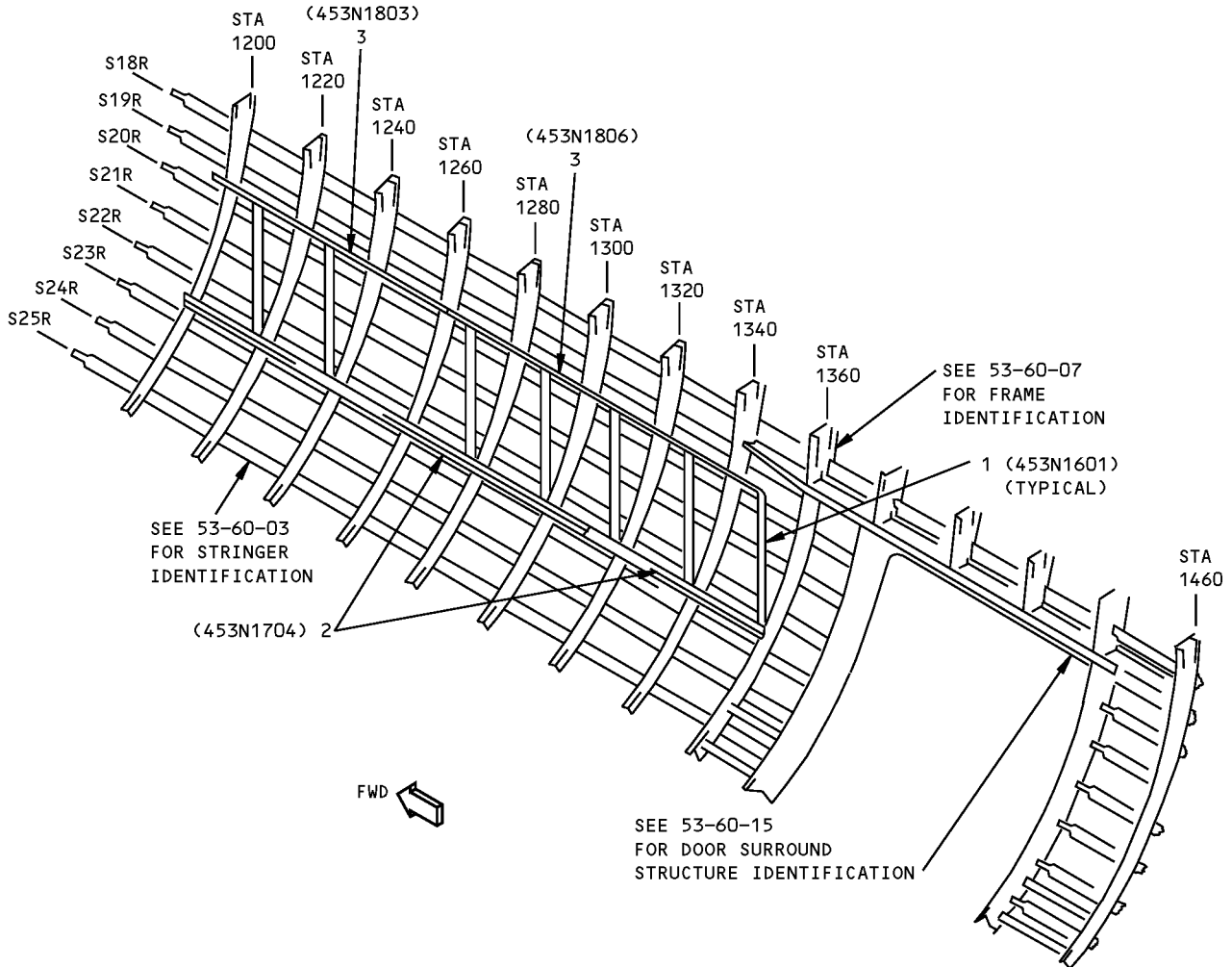
IDENTIFICATION 1
Page 3
Jan 20/2005

53-60-53

D634N201

**757-200
STRUCTURAL REPAIR MANUAL**

REF DWG
453N1230



DETAIL III

ITEM	DESCRIPTION	GAGE	MATERIAL	EFFECTIVITY
1	STANCHION		GRAPHITE/EPOXY LAMINATE	
2	ANGLE		BAC1489-290 CLAD 2024-T3	
3	ANGLE	0.063	2024-T42	

LIST OF MATERIALS FOR DETAIL III

**Section 46 Cargo Compartment Structure Identification
Figure 1 (Sheet 4 of 13)**

IDENTIFICATION 1
Page 4
Jan 20/2005

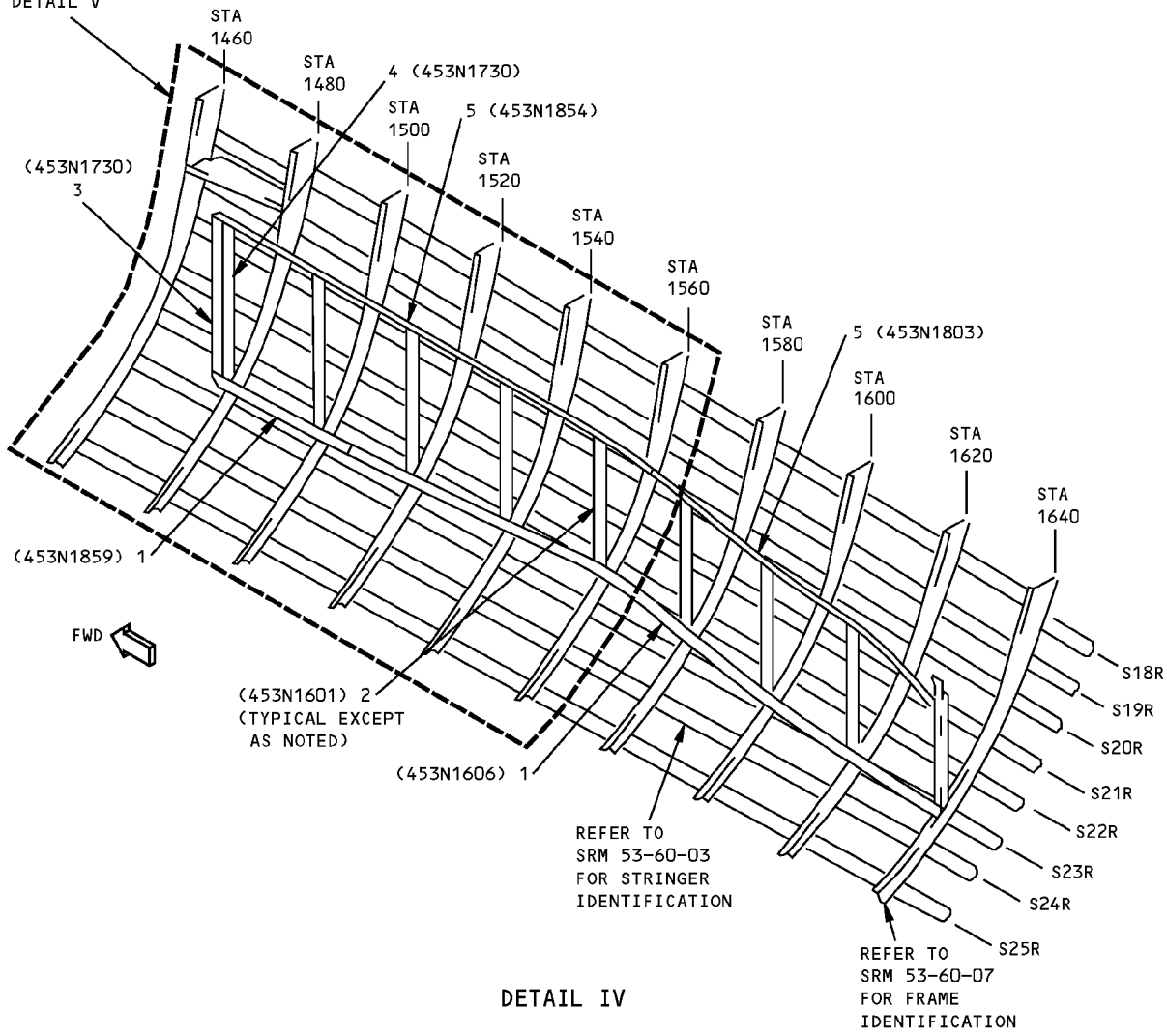
53-60-53

D634N201

**757-200
STRUCTURAL REPAIR MANUAL**

SEE DETAIL VI A
SEE DETAIL V

REF DWG
453N1230



DETAIL IV

ITEM	DESCRIPTION	GAGE	MATERIAL	EFFECTIVITY
1	ANGLE	0.063	CLAD 2024-T3	
2	STANCHION		GRAPHITE/EPOXY LAMINATE	
3	STANCHION		BAC1501-100032 2024-T3	
4	STANCHION		BAC1505-100349 2024-T3511	
5	ANGLE	0.063	2024-T42	

LIST OF MATERIALS FOR DETAIL IV

**Section 46 Cargo Compartment Structure Identification
Figure 1 (Sheet 5 of 13)**

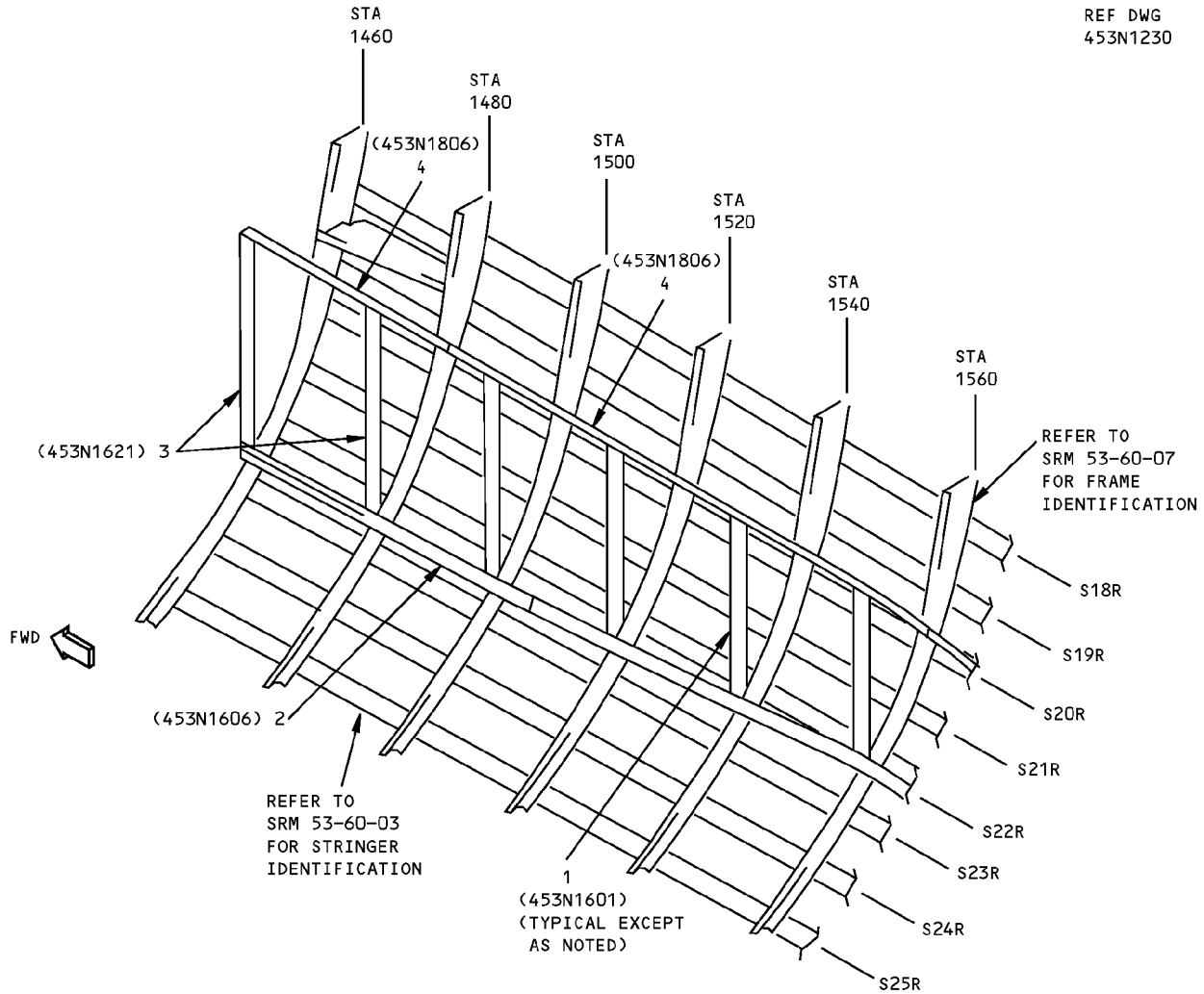
IDENTIFICATION 1
Page 5
Jan 20/2005

53-60-53

D634N201

**757-200
STRUCTURAL REPAIR MANUAL**

REF DWG
453N1230



DETAIL V

ITEM	DESCRIPTION	GAGE	MATERIAL	EFFECTIVITY
1	STANCHION		GRAPHITE/EPOXY LAMINATE	
2	ANGLE	0.063	CLAD 2024-T3	
3	STANCHION		BAC1501-100032 2024-T3	
4	ANGLE	0.063	2024-T42	

LIST OF MATERIALS FOR DETAIL V

**Section 46 Cargo Compartment Structure Identification
Figure 1 (Sheet 6 of 13)**

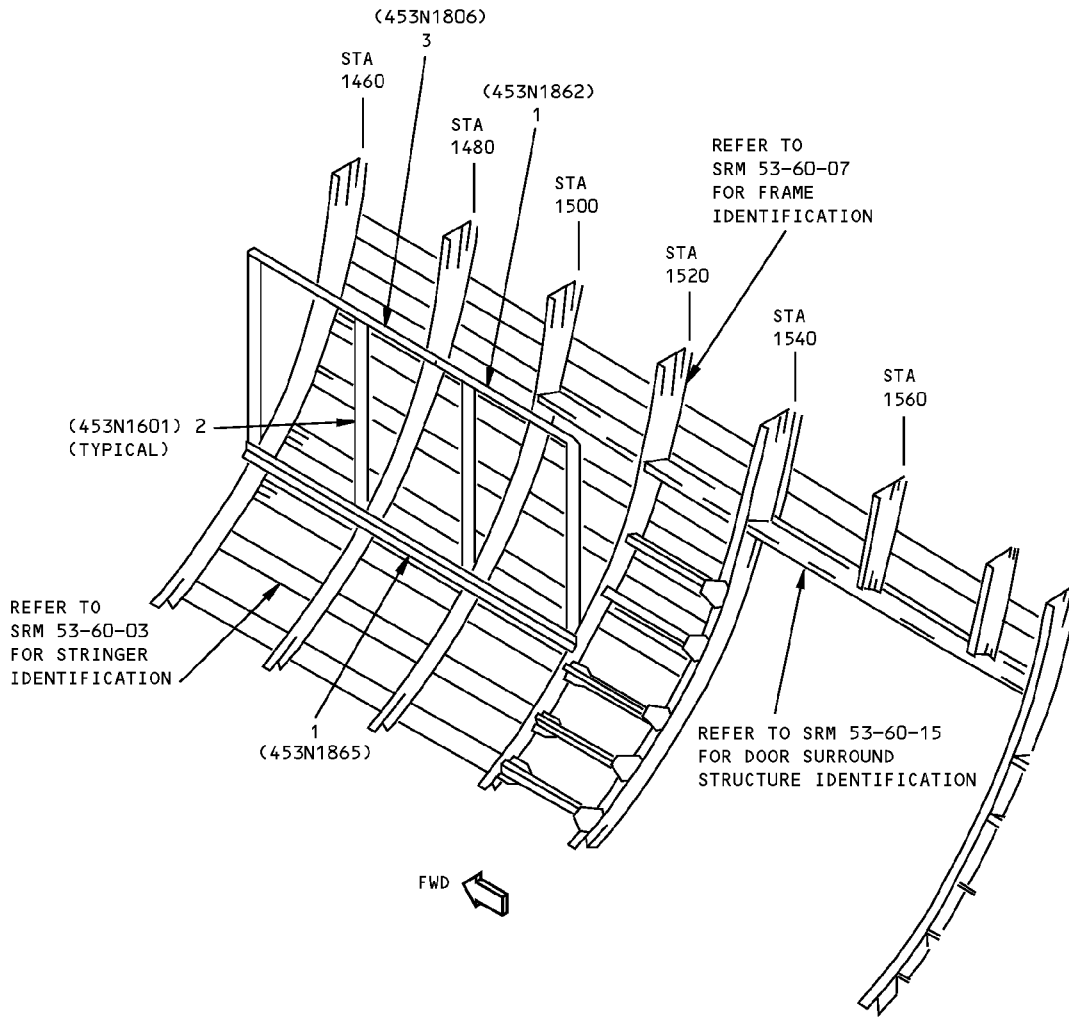
IDENTIFICATION 1
Page 6
Jan 20/2005

53-60-53

D634N201

**757-200
STRUCTURAL REPAIR MANUAL**

REF DWG
453N1230



DETAIL VI A

ITEM	DESCRIPTION	GAGE	MATERIAL	EFFECTIVITY
1	ANGLE	0.063	CLAD 2024-T3	
2	STANCHION		GRAPHITE/EPOXY LAMINATE	
3	ANGLE	0.063	2024-T42	

LIST OF MATERIALS FOR DETAIL VI

**Section 46 Cargo Compartment Structure Identification
Figure 1 (Sheet 7 of 13)**

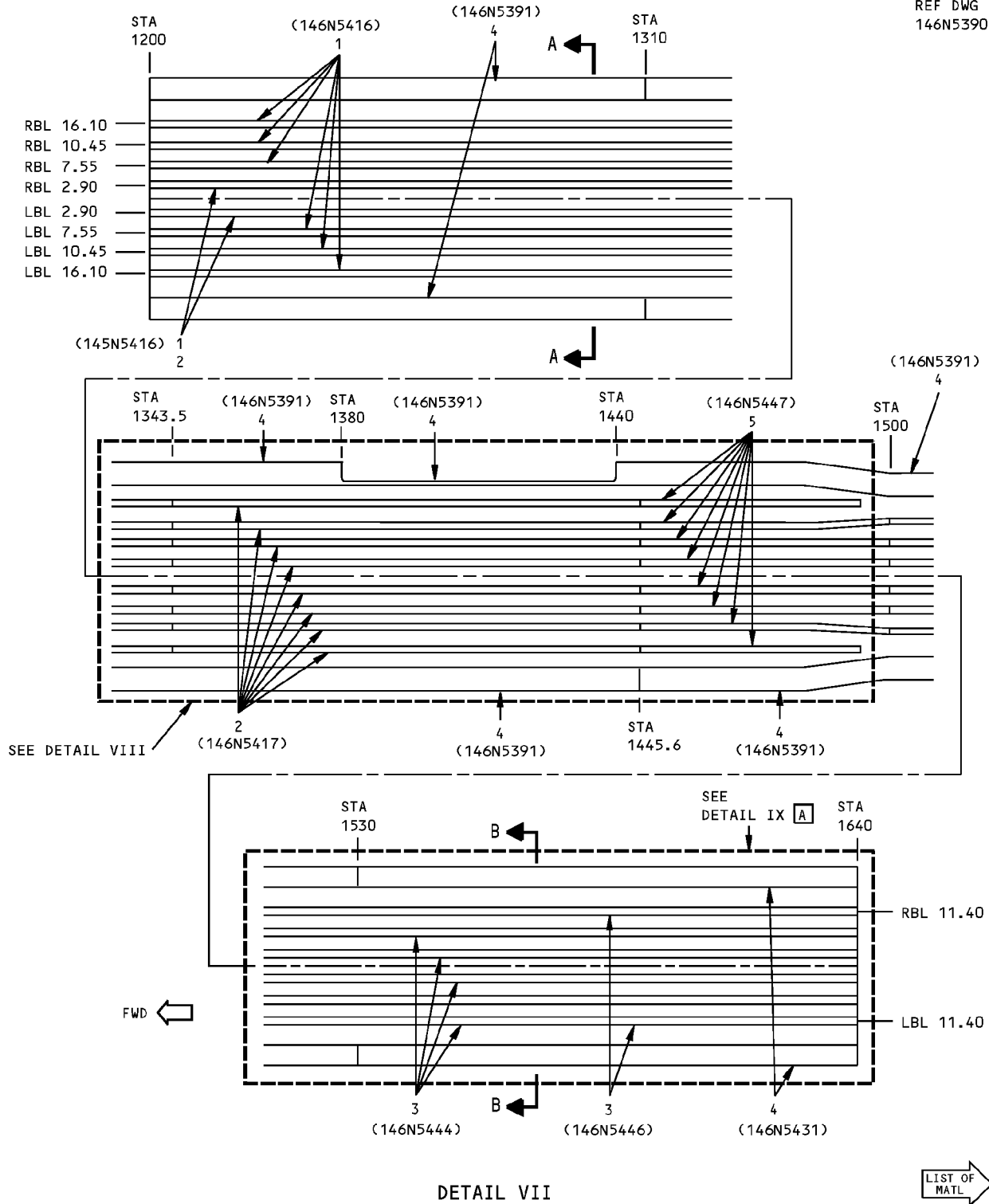
IDENTIFICATION 1
Page 7
Jan 20/2005

53-60-53

D634N201

**757-200
STRUCTURAL REPAIR MANUAL**

REF DWG
146N5390



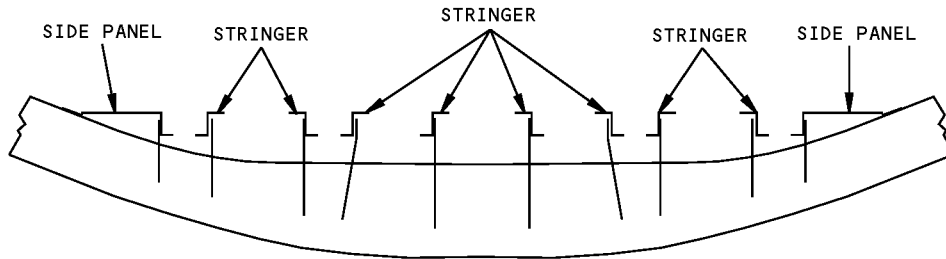
**Section 46 Cargo Compartment Structure Identification
Figure 1 (Sheet 8 of 13)**

IDENTIFICATION 1
Page 8
Jan 20/2005

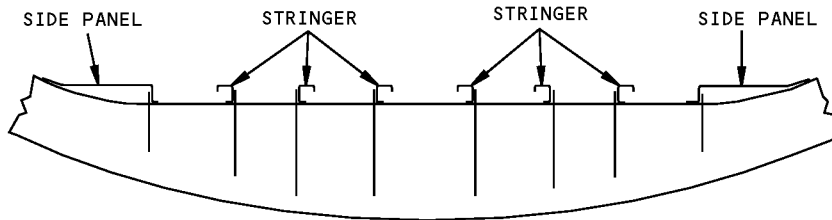
53-60-53

D634N201

**757-200
STRUCTURAL REPAIR MANUAL**



SECTION A-A
(ROTATED 90° CW)



SECTION B-B
(ROTATED 90° CW)

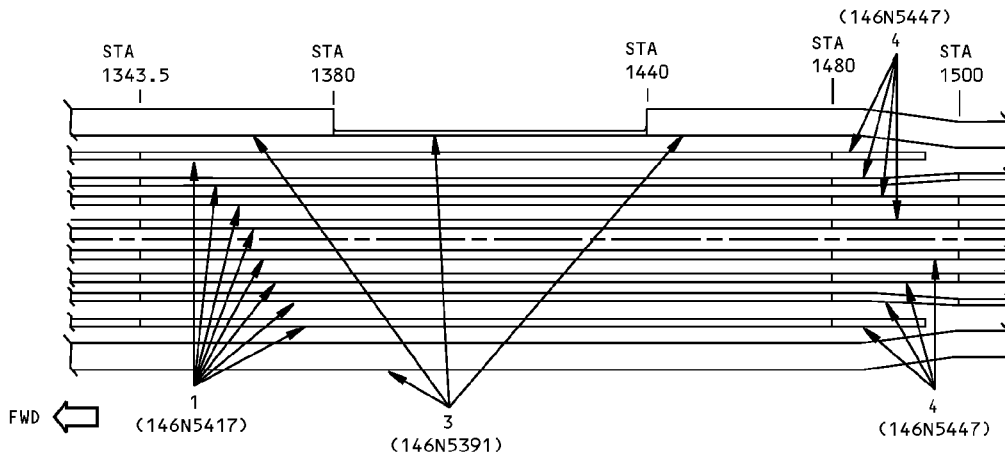
ITEM	DESCRIPTION	GAGE	MATERIAL	EFFECTIVITY
1	STRINGER		BAC1517-2226 7075-T6511 OPTIONAL: BAC1517-2229 7075-T6	
2	STRINGER		BAC1517-2226 7075-T6511	
3	STRINGER		BAC1510-1087 7075-T6511 OPTIONAL: BAC1495-172 7075-T6	
4	SIDE PANELS	0.063	CLAD 7075-T6	
5	STRINGER	0.063	7075-T6	

LIST OF MATERIALS FOR DETAIL VII

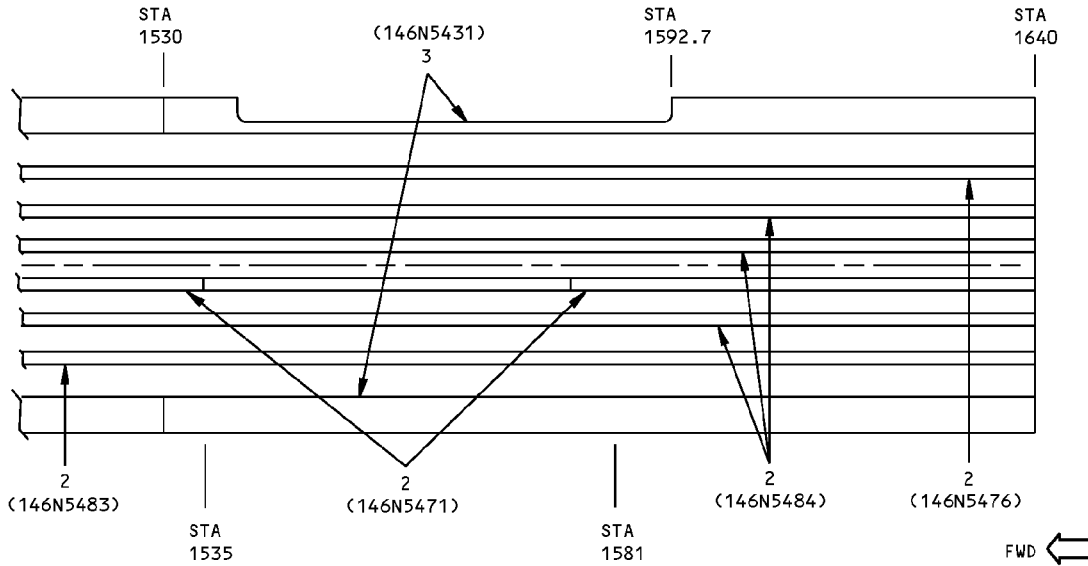
**Section 46 Cargo Compartment Structure Identification
Figure 1 (Sheet 9 of 13)**

757-200 STRUCTURAL REPAIR MANUAL

REF DWG
146N5390



DETAIL VIII



DETAIL IX

ITEM	DESCRIPTION	GAGE	MATERIAL	EFFECTIVITY
1	STRINGER		BAC1517-2226 7075-T6511 OPTIONAL: BAC1517-2229 7075-T6	
2	STRINGER		BAC1510-1087 7075-T6511	
3	SIDE PANEL	0.063	CLAD 7075-T6	
4	STRINGER	0.063	7075-T6	

LIST OF MATERIALS FOR DETAILS VIII AND IX

**Section 46 Cargo Compartment Structure Identification
Figure 1 (Sheet 10 of 13)**

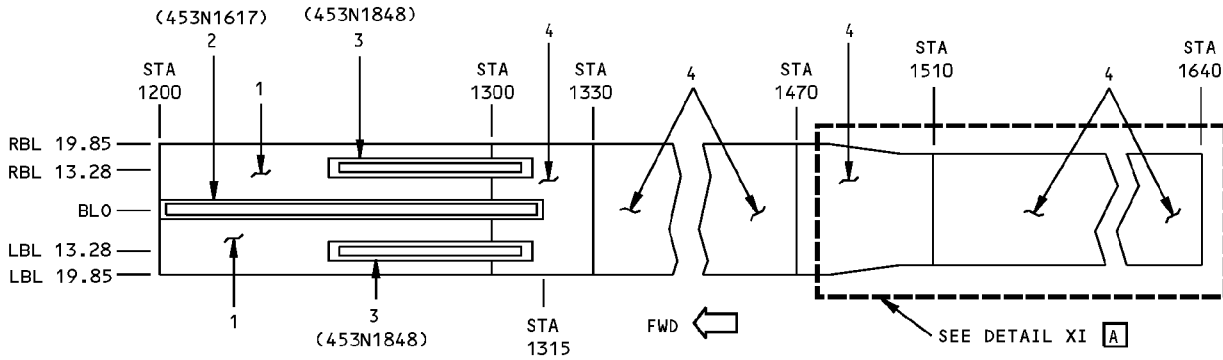
IDENTIFICATION 1
Page 10
Jan 20/2005

53-60-53

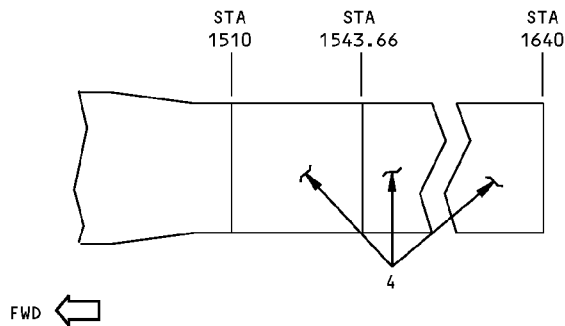
D634N201

**757-200
STRUCTURAL REPAIR MANUAL**

REF DWG
453N1270



**DECK PLATE LOCATIONS FOR AIRPLANES WITH ACE BAGGAGE LOADER
DETAIL X**



DETAIL XI A

ITEM	DESCRIPTION	GAGE	MATERIAL	EFFECTIVITY
1	PLATE	0.020	CLAD 2024-T3	
2	PAN	0.032	6061-T4	
3	PAN	0.040	2024-T4	
4	PLATE	0.050	CLAD 2024-T3	

LIST OF MATERIALS FOR DETAILS X AND XI

**Section 46 Cargo Compartment Structure Identification
Figure 1 (Sheet 11 of 13)**

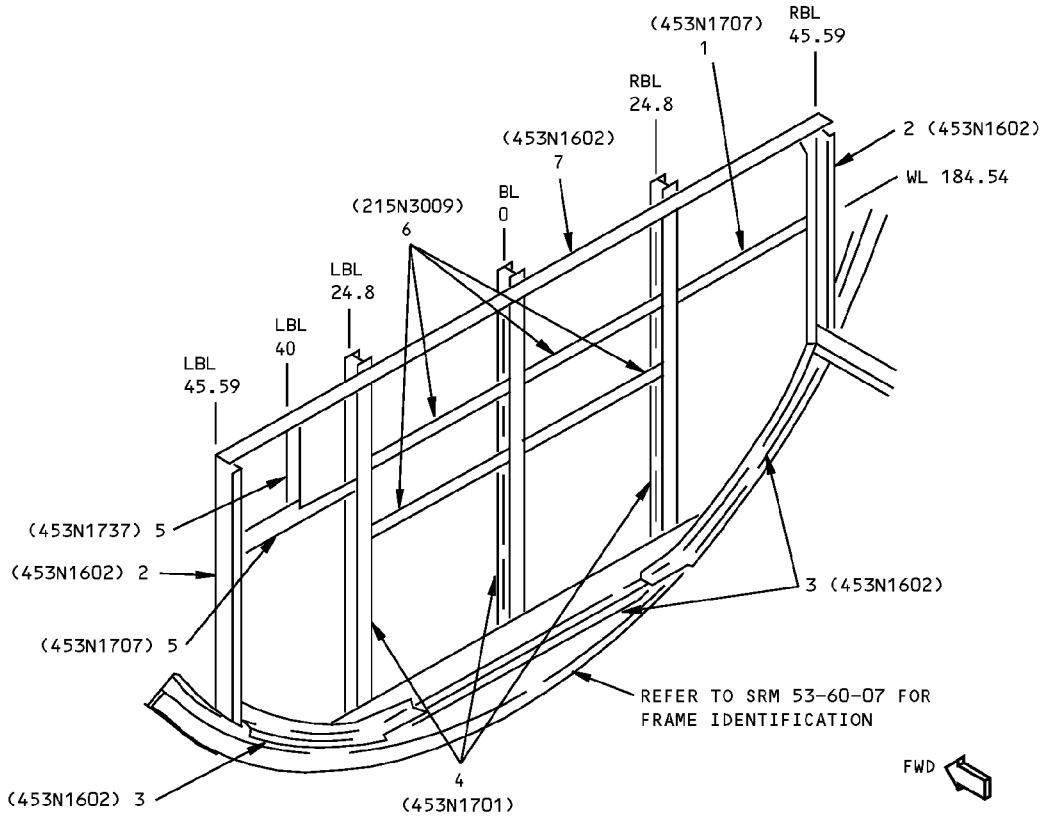
IDENTIFICATION 1
Page 11
Jan 20/2005

53-60-53

D634N201

**757-200
STRUCTURAL REPAIR MANUAL**

REF DWG
453N1250



DETAIL XII

ITEM	DESCRIPTION	GAGE	MATERIAL	EFFECTIVITY
1	TEE		AND10136-1601 7075-T6511 AND10136-1608 7075-T6511	
2	SUPPORT	0.071	CLAD 7075-T6	
3	SUPPORT	0.050	CLAD 2024-T42	
4	STANCHION		GRAPHITE/EPOXY LAMINATE	
5	TEE		AND10136-1601 7075-T6511	
6	TEE		AND10136-1403 2024-T3511	
7	ANGLE	0.050	2024-T3	

LIST OF MATERIALS FOR DETAILS XII

**Section 46 Cargo Compartment Structure Identification
Figure 1 (Sheet 12 of 13)**

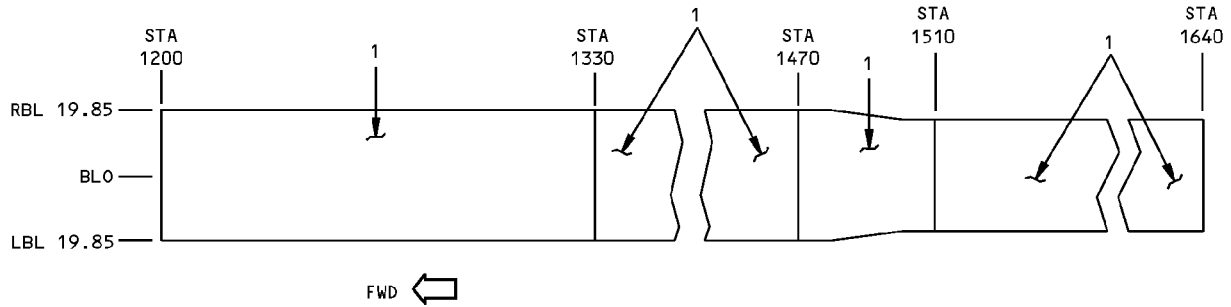
IDENTIFICATION 1
Page 12
Jan 20/2005

53-60-53

D634N201

**757-200
STRUCTURAL REPAIR MANUAL**

REF DWG
453N1270



DECK PLATE LOCATIONS FOR AIRPLANES WITHOUT ACE BAGGAGE LOADER
DETAIL XIII

ITEM	DESCRIPTION	GAGE	MATERIAL	EFFECTIVITY
1	PLATE	0.050 0.071	CLAD 2024-T3 CLAD 2024-T3	B

LIST OF MATERIALS FOR DETAIL XIII

**Section 46 Cargo Compartment Structure Identification
Figure 1 (Sheet 13 of 13)**

IDENTIFICATION 1
Page 13
Jan 20/2005

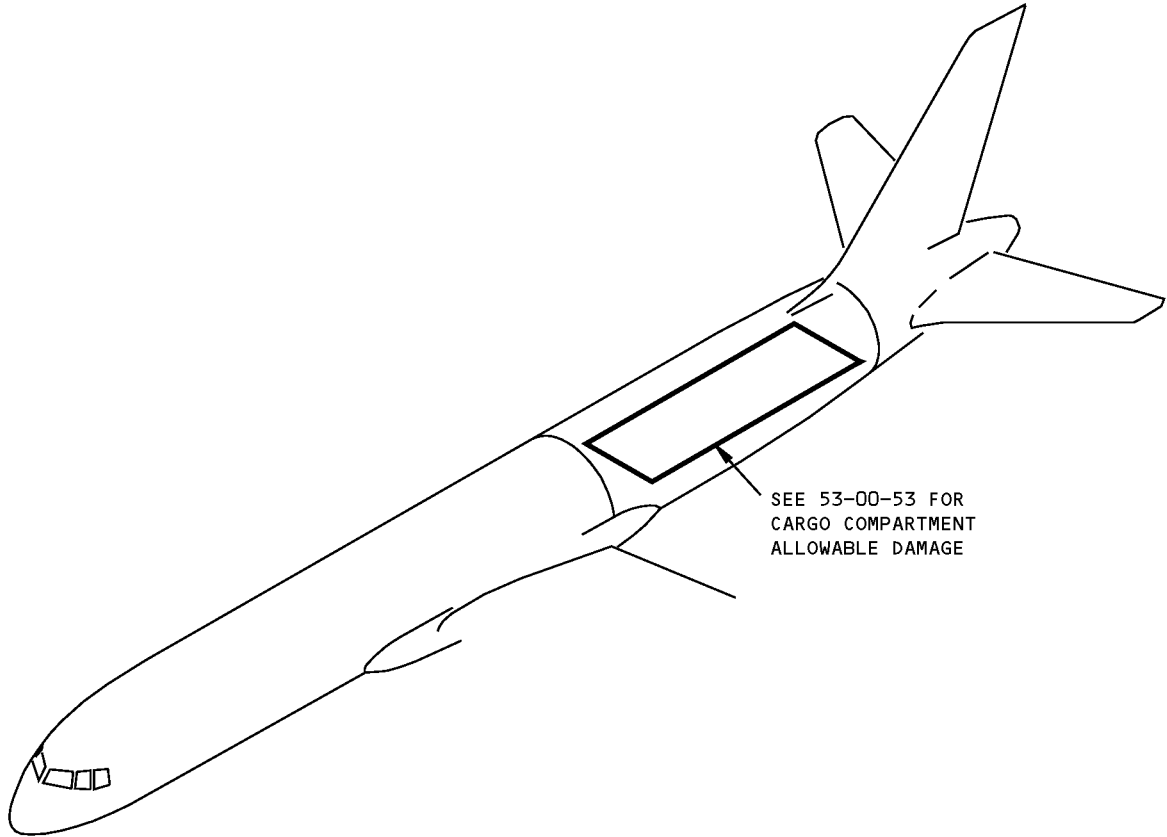
53-60-53

D634N201



**757-200
STRUCTURAL REPAIR MANUAL**

ALLOWABLE DAMAGE GENERAL - SECTION 46 - CARGO COMPARTMENT FLOOR STRUCTURE



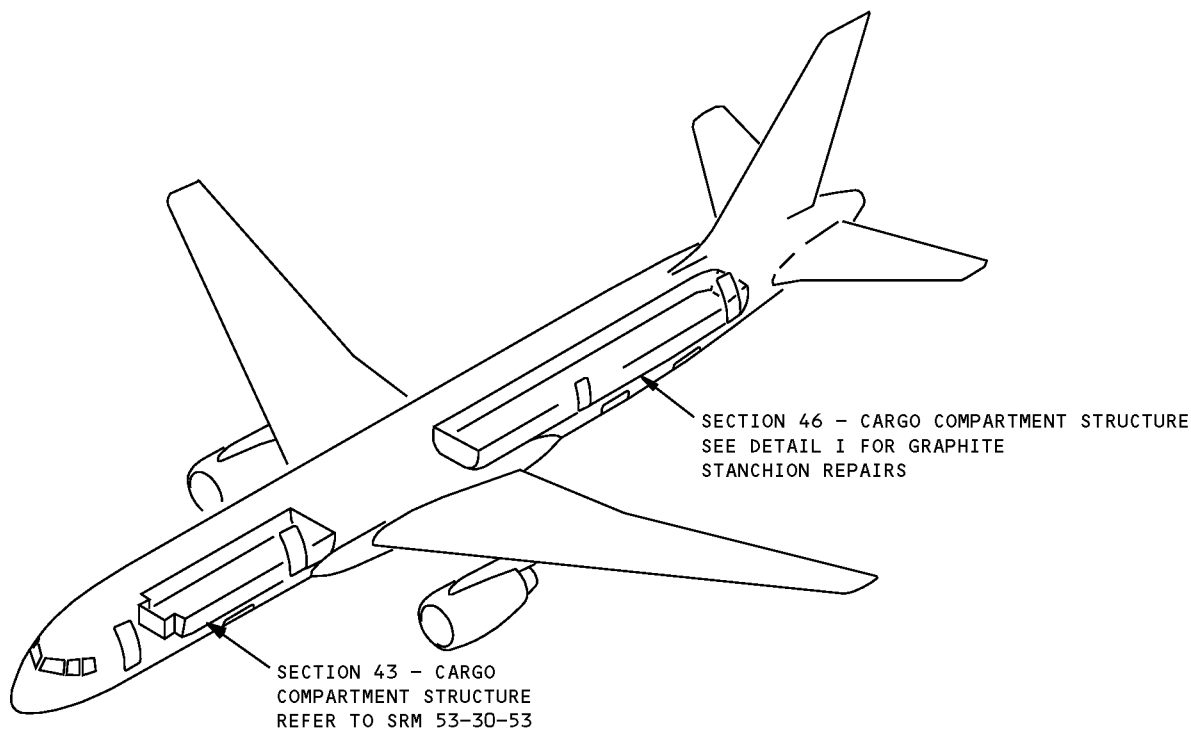
**Section 46 Cargo Compartment Floor Structure Allowable Damage
Figure 101**

D634N201

ALLOWABLE DAMAGE GENERAL
53-60-53 Page 101
Jan 20/2005

757-200
STRUCTURAL REPAIR MANUAL

REPAIR GENERAL - SECTION 46 - CARGO COMPARTMENT FLOOR STRUCTURE

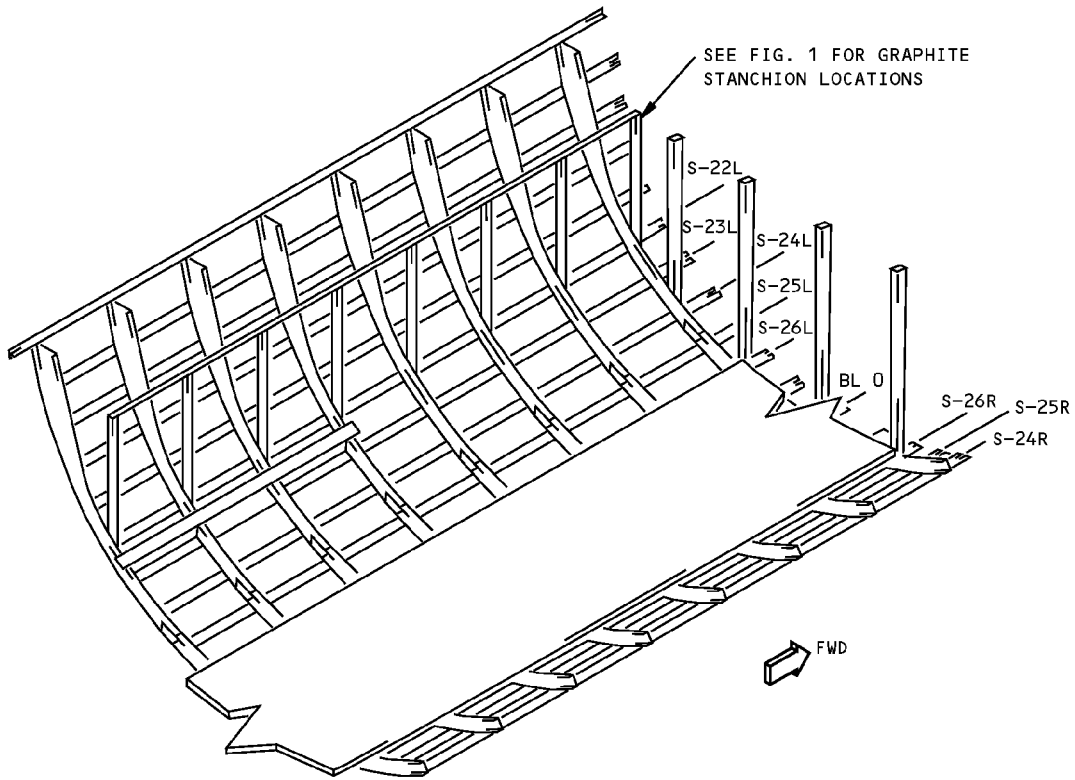


NOTES

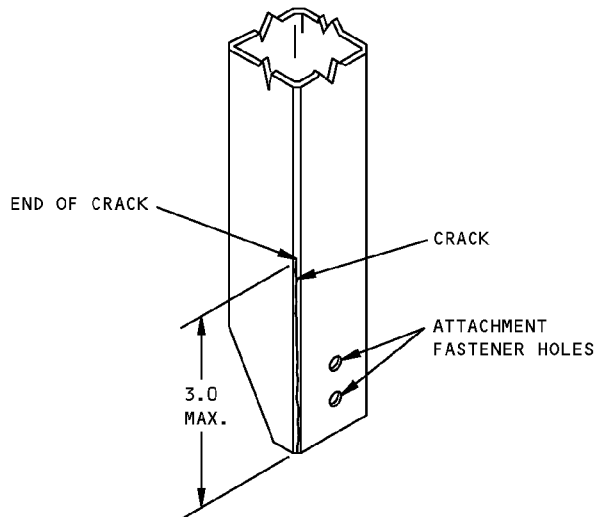
- THIS REPAIR DATA IS APPLICABLE TO PASSENGER AIRPLANES ONLY
- REFER TO AMM 25-50-09 FOR REPAIRS TO THE CARGO SIDEWALL LINER. THE LINERS PROVIDE A FIRE AND SMOKE BARRIER
- REFER TO SRM 51-70-11 FOR FORMED SECTION REPAIR
- REFER TO SRM 51-70-12 FOR EXTRUDED SECTION REPAIR
- REFER TO SRM 51-70-13 FOR WEB REPAIRS
- FITTING REPAIRS ARE NOT PERMITTED
- A CRACK REPAIR TO GRAPHITE STANCHIONS IS PERMITTED IF, THE CRACK IS LOCATED IN A CORNER AND THE CRACK LENGTH IS NOT MORE THAN A MAXIMUM OF 3.0 INCHES (75 mm)
- REPAIR GRAPHITE STANCHIONS AS GIVEN IN SRM 51-70-03, PARAGRAPH 5.P. ONLY IF THESE CONDITIONS ARE MET
- AT THE NEXT "C" CHECK, REPLACE ANY DAMAGED GRAPHITE STANCHION WITH A NEW STANCHION MADE OF GRAPHITE OR ALUMINUM MATERIAL
- STANCHIONS WITH DAMAGE EXCEEDING THE LIMITS AS GIVEN MUST BE REPLACED

Section 46 Cargo Compartment Floor Structure Repair
Figure 201 (Sheet 1 of 2)

**757-200
STRUCTURAL REPAIR MANUAL**



TYPICAL CARGO COMPARTMENT STRUCTURE



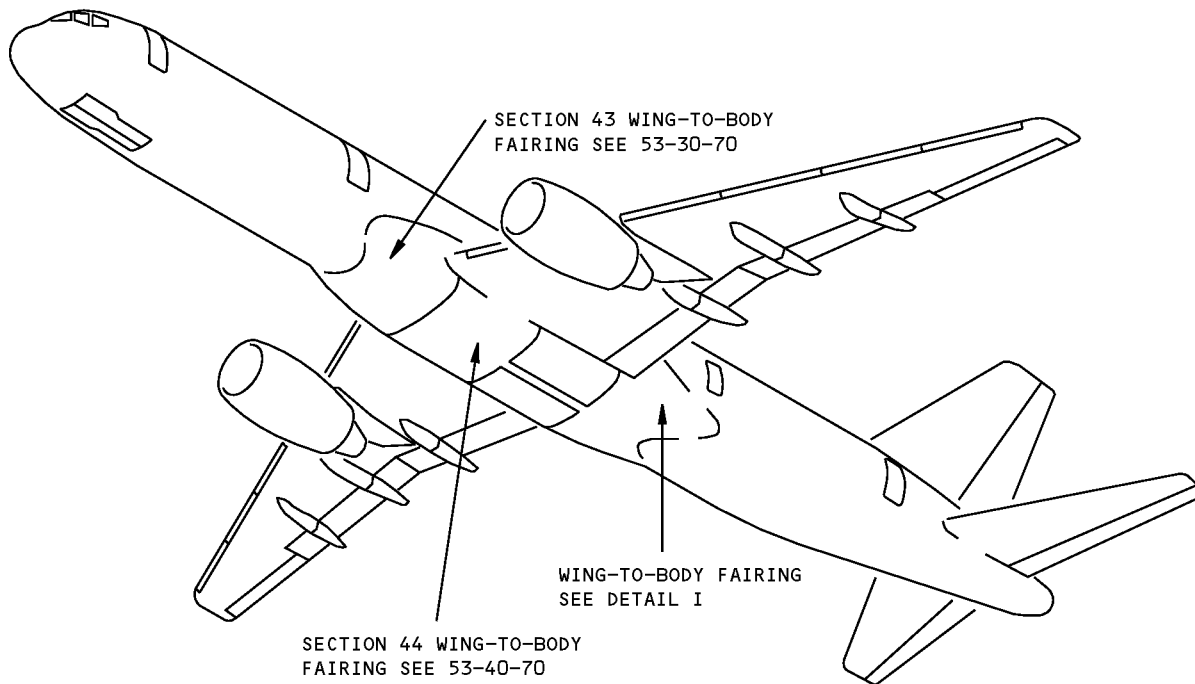
TYPICAL GRAPHITE STANCHION

GRAPHITE STANCHION REPAIR
DETAIL I

**Section 46 Cargo Compartment Floor Structure Repair
Figure 201 (Sheet 2 of 2)**

**757-200
STRUCTURAL REPAIR MANUAL**

IDENTIFICATION 1 - SECTION 46 - WING-TO-BODY FAIRING SKINS



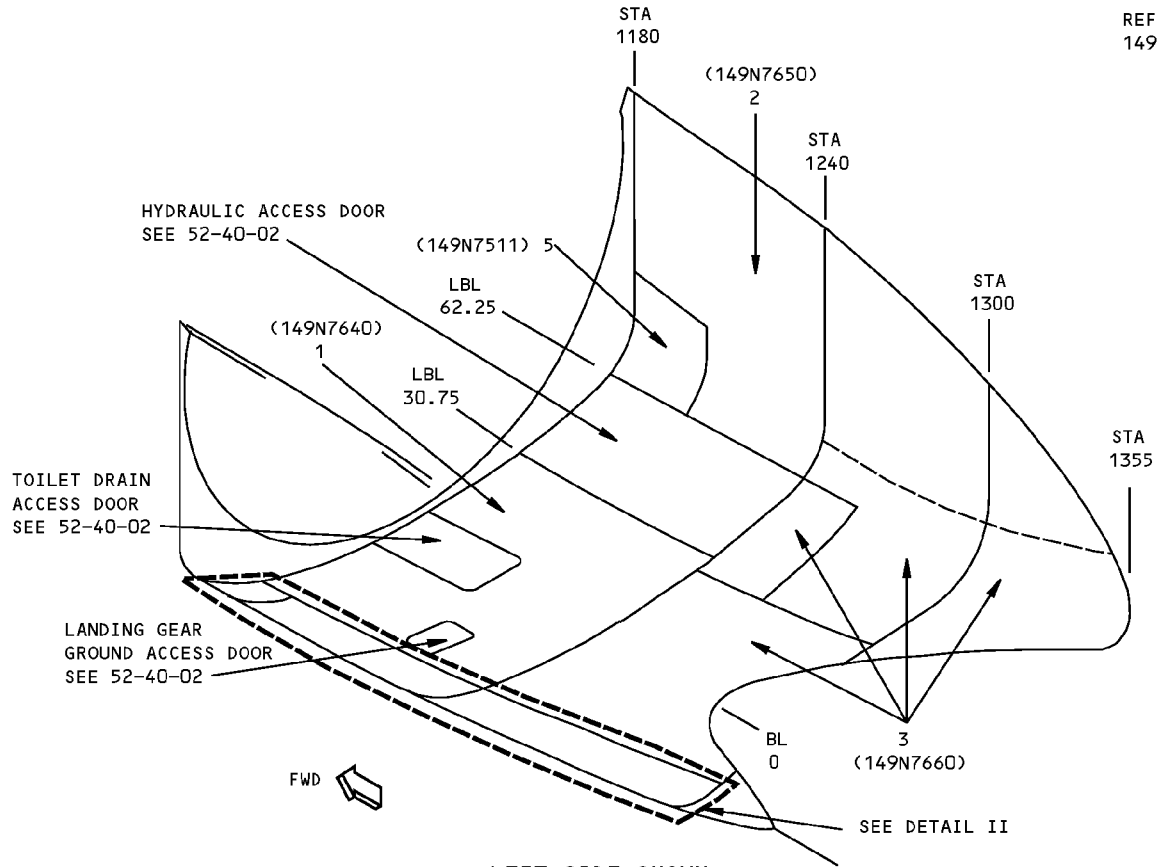
NOTES

- | | |
|--|---|
| <p>A PLY ORIENTATION CONVENTION, DEGREES INDICATED, IS PARALLEL TO THE FABRIC WARP DIRECTION</p> <p>B ALUMINUM COATED FIBERGLASS PER BMS 8-278, TYPE II, CLASS 250, 250°F (121°C) CURE</p> <p>C ARAMID/EPOXY FABRIC PER BMS 8-219, STYLE 120, 250°F (121°C) CURE</p> <p>D GRAPHITE/EPOXY TAPE PER BMS 8-168, TYPE II, CLASS I, GRADE 145, 250°F (121°C) CURE</p> <p>E GRAPHITE/EPOXY FABRIC PER BMS 8-168, TYPE II, CLASS II, STYLE 3K-70-PW, 250°F (121°C) CURE</p> <p>F MATERIAL AND PLY ORIENTATION SHOWN FOR FIELD AREAS ONLY. SEE BOEING DRAWING FOR EDGE BANDS AND AREAS WITH DOUBLERS</p> <p>G DIAGRAM OF PLY ORIENTATION. SEE PLY TABLE FOR INDIVIDUAL PLY ORIENTATION AND MATERIAL</p> | <p>H FIBERGLASS/EPOXY FABRIC PER BMS 8-79, TYPE 120, 250°F (121°C) CURE</p> <p>I ARAMID/EPOXY FABRIC PER BMS 8-219, STYLE 285, 250°F (121°C) CURE</p> <p>J OPTIONAL FOR CUM LINE NUMBERS: 1 THRU 9</p> <p>K ALUMINUM COATED FIBERGLASS PER BMS 8-278, TYPE I, CLASS 250, 250°F (121°C) CURE</p> <p>L FOR CUM LINE NUMBERS: 1 THRU 193</p> <p>M FOR CUM LINE NUMBERS: 194 AND ON</p> <p>N FOR CUM LINE NUMBERS: 1 THRU 316</p> <p>O FOR CUM LINE NUMBERS: 317 AND ON</p> |
|--|---|

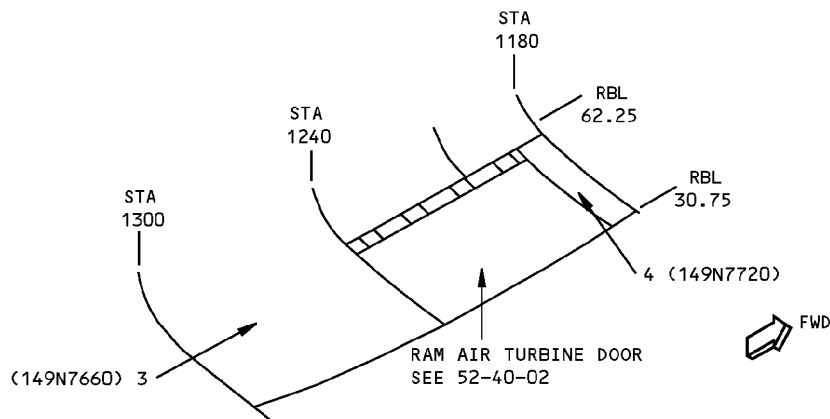
**Section 46 Wing-To-Body Fairing Skin Identification
Figure 1 (Sheet 1 of 8)**

**757-200
STRUCTURAL REPAIR MANUAL**

REF DWG
149N7601



LEFT SIDE SHOWN
RIGHT SIDE OPPOSITE
EXCEPT AS NOTED
DETAIL I



RIGHT SIDE ONLY
DETAIL II

LIST OF
MATL

**Section 46 Wing-To-Body Fairing Skin Identification
Figure 1 (Sheet 2 of 8)**

IDENTIFICATION 1
Page 2
Jan 20/2005

53-60-70

D634N201



757-200
STRUCTURAL REPAIR MANUAL

ITEM	DESCRIPTION	GAGE	MATERIAL	EFFECTIVITY
1	SKIN PANEL SKIN CORE		ARAMID/GRAPHITE/EPOXY HONEYCOMB SANDWICH SEE DETAIL III NOMEX HONEYCOMB PER BMS 8-124, CLASS IV, TYPE V, GRADE 3.0	
2	SKIN PANEL SKIN CORE		ARAMID/GRAPHITE/EPOXY HONEYCOMB SANDWICH SEE DETAIL IV NOMEX HONEYCOMB PER BMS 8-124, CLASS IV, TYPE V, GRADE 3.0	
3	SKIN PANEL SKIN CORE		ARAMID/GRAPHITE/EPOXY HONEYCOMB SANDWICH SEE DETAIL V NOMEX HONEYCOMB PER BMS 8-124, CLASS IV, TYPE V, GRADE 3.0	
4	CLOSURE PANEL		ARAMID/EPOXY LAMINATE SEE DETAIL VII	
5	FLAP TRACK PANEL SKIN CORE		ARAMID/GRAPHITE/EPOXY HONEYCOMB SANDWICH SEE DETAIL VI NOMEX HONEYCOMB PER BMS 8-124, CLASS IV, TYPE V, GRADE 3.0	

LIST OF MATERIALS FOR DETAILS I AND II

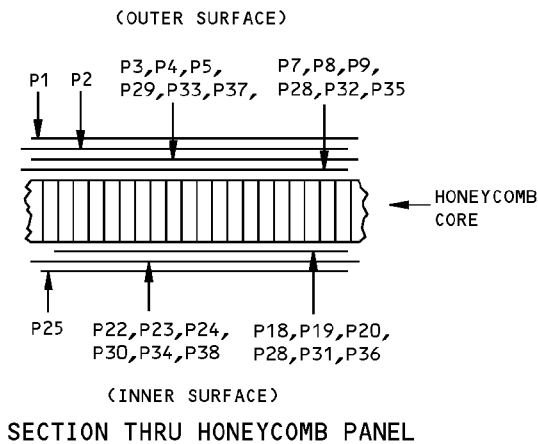
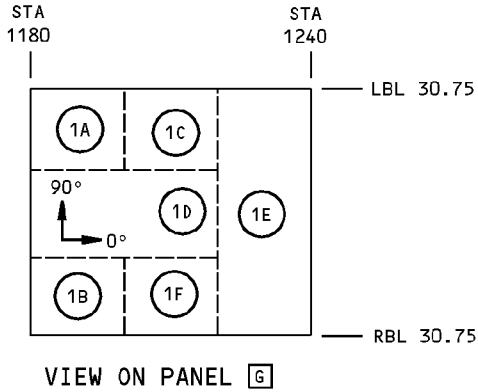
Section 46 Wing-To-Body Fairing Skin Identification
Figure 1 (Sheet 3 of 8)

D634N201

53-60-70

IDENTIFICATION 1
Page 3
Jan 20/2005

**757-200
STRUCTURAL REPAIR MANUAL**



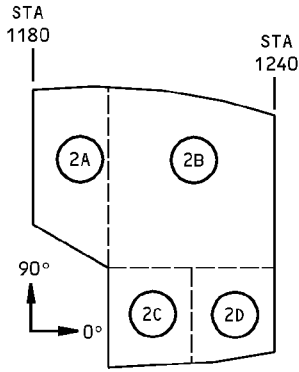
ITEM NO.	PLY NO.	MATERIAL	PLY ORIENTATION A	
1	1A	P1 L	B	0° OR 90°
		P1 M	K	
		P2,P25	C	0° OR 90°
		P29,P30	D	0°
	1B	P1 L	B	0° OR 90°
		P1 M	K	
		P2,P25	C	0° OR 90°
		P5,P24	D	0°
	1C	P1 L	B	0° OR 90°
		P1 M	K	
		P2,P25	C	0° OR 90°
		P33,P34	D	0°
1D	P1 L	B	0° OR 90°	
	P1 M	K		
	P2,P25	C	0° OR 90°	
	P37,P38	D	0°	
1E	P1 L	B	0° OR 90°	
	P1 M	K		
	P2,P25	C	0° OR 90°	
	P4,P23	D	0°	
1F	P1 L	B	0° OR 90°	
	P1 M	K		
	P2,P25	C	0° OR 90°	
	P3,P22	D	0°	
		P7,P18	E	0° OR 90°

PLY TABLE F

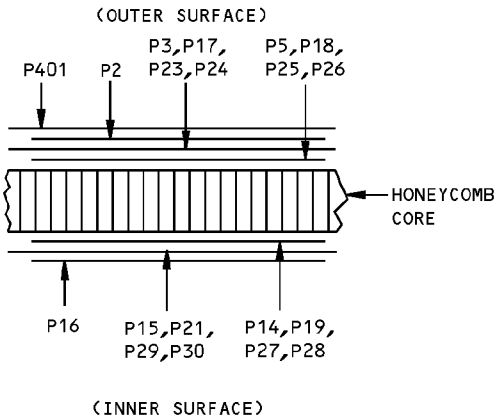
DETAIL III

**Section 46 Wing-To-Body Fairing Skin Identification
Figure 1 (Sheet 4 of 8)**

**757-200
STRUCTURAL REPAIR MANUAL**



VIEW ON PANEL **G**



SECTION THRU HONEYCOMB PANEL

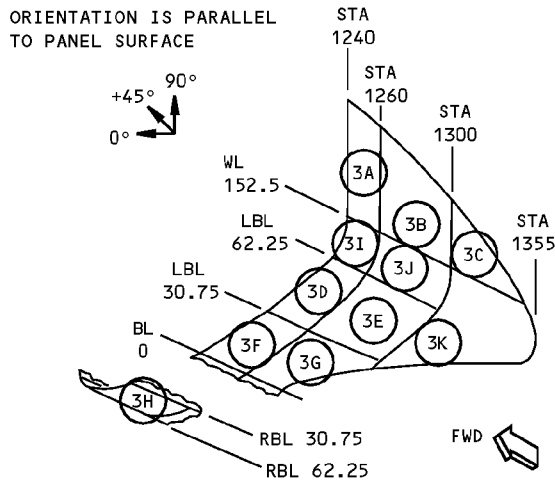
ITEM NO.	PLY NO.	MATERIAL	PLY ORIENTATION A
2	2A	P401 J P401	B H 0° OR 90°
		P2,P16	C 0° OR 90°
		P3,P15	D 0°
		P5,P14	E 0° OR 90°
	2B	P401 J P401	B H 0° OR 90°
		P2,P16	C 0° OR 90°
		P17,P21	D 0°
		P18,P19	E 0° OR 90°
	2C	P401 J P401	B H 0° OR 90°
		P2,P16	C 0° OR 90°
		P29	D 90°
		P25,P27	E 0° OR 90°
2D	P401 J P401	B H 0° OR 90°	
	P2,P16	C 0° OR 90°	
	P24	D 90°	
	P30	D 0°	
	P26,P28	E 0° OR 90°	

PLY TABLE **F**

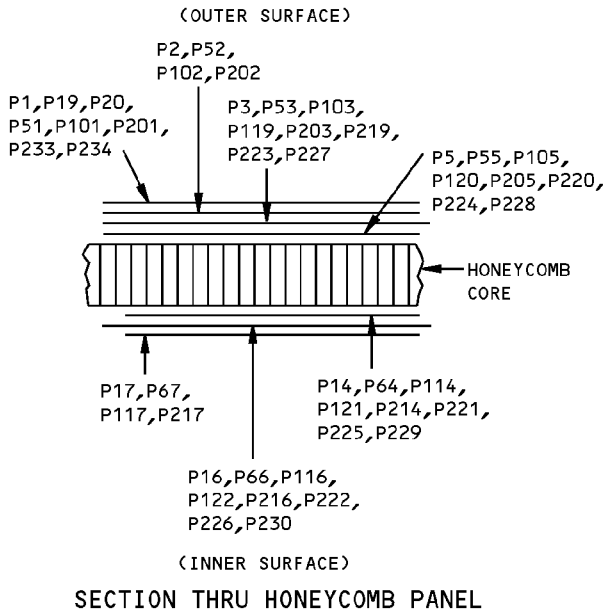
DETAIL IV

**Section 46 Wing-To-Body Fairing Skin Identification
Figure 1 (Sheet 5 of 8)**

**757-200
STRUCTURAL REPAIR MANUAL**



VIEW ON PANELS **[G]**



SECTION THRU HONEYCOMB PANEL

ITEM NO.	PLY NO.	MATERIAL	PLY ORIENTATION [A]
3	(3A)	P234 [J] P234	[B] [H] 0° OR 90°
		P202 P217	[C] 0° OR 90°
		P203 P216	[E] 0°
		P205 P214	[E] 0° OR 90°
	(3B)	P234 [J] P234	[B] [H] 0° OR 90°
		P202 P217	[C] 0° OR 90°
		P219 P222	[D] 0°
		P220 P221	[E] 0° OR 90°
	(3C)	P20 [J] P20	[B] [H] 0° OR 90°
		P2, P17	[C] 0° OR 90°
		P3, P16	[E] 0°
	(3D)	P5, P14	[E] 0° OR 90°
P51 [L] P51 [M]		[B] [K] 0° OR 90°	
P52, P67		[C] 0° OR 90°	
P53, P66		[D] 0°	
(3E)	P55, P64	[E] 0° OR 90°	
	P201 [L] P201 [M]	[B] [K] 0° OR 90°	
	P202 P217	[C] 0° OR 90°	
	P223 P226	[D] 0°	
(3H)	P224 P225	[E] 0° OR 90°	

PLY TABLE **[F]**

DETAIL V

**Section 46 Wing-To-Body Fairing Skin Identification
Figure 1 (Sheet 6 of 8)**

IDENTIFICATION 1
Page 6
Jan 20/2005

53-60-70

D634N201

**757-200
STRUCTURAL REPAIR MANUAL**

ITEM NO.	PLY NO.	MATERIAL	PLY ORIENTATION ^A
3	3F	P101 ^L P101 ^M	^B ^K 0° OR 90°
		P102 P217	^C 0° OR 90°
		P119 P122	^D 0°
		P120 P121	^E 0° OR 90°
	3G	P101 ^L P101 ^M	^B ^K 0° OR 90°
		P102 P116	^C 0° OR 90°
		P103 P116	^D 0°
		P105 P114	^E 0° OR 90°
	3H	P201 ^L P201 ^M	^B ^K 0° OR 90°
		P202 P217	^C 0° OR 90°
		P227 P230	^E 0°
		P228 P229	^E 0° OR 90°
3I	P201 ^L P233 ^M	^B ^K 0° OR 90°	
	P202 P217	^C 0° OR 90°	
	P203 P216	^E 0°	
	P205 P214	^E 0° OR 90°	

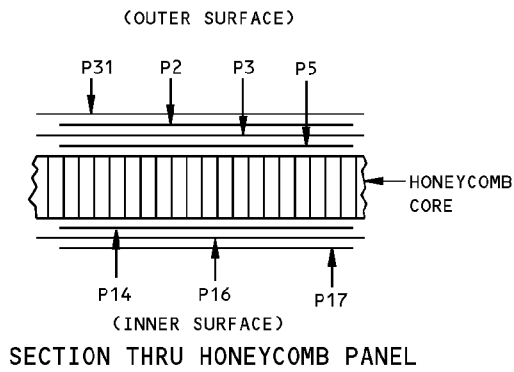
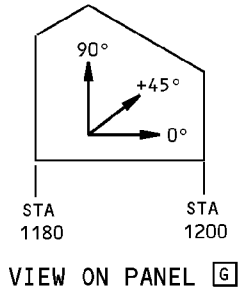
PLY TABLE FOR DETAIL V (CONTINUED) ^F

ITEM NO.	PLY NO.	MATERIAL	PLY ORIENTATION ^A
3	3J	P201 ^L P233 ^M	^B ^K 0° OR 90°
		P202 P217	^C 0° OR 90°
		P219 P222	^D 0°
		P220 P221	^E 0° OR 90°
	3K	P1,P19 ^L P19 ^M	^B ^K 0° OR 90°
		P2,P17	^C 0° OR 90°
		P3,P16	^E 0°
		P5,P14	^E 0° OR 90°

PLY TABLE FOR DETAIL V (CONTINUED) ^F

**Section 46 Wing-To-Body Fairing Skin Identification
Figure 1 (Sheet 7 of 8)**

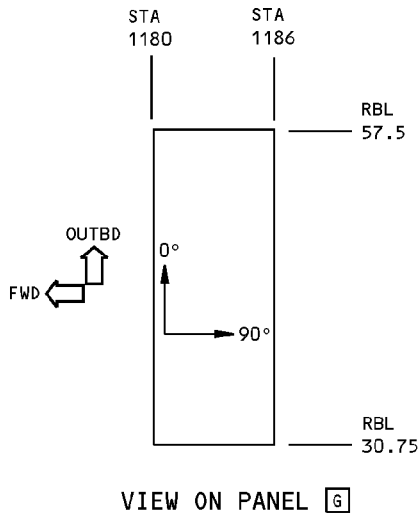
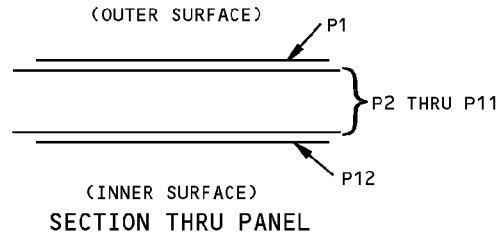
**757-200
STRUCTURAL REPAIR MANUAL**



ITEM NO.	PLY NO.	MATERIAL	PLY ORIENTATION A
5	P31 J	B	0° OR 90°
	P31	H	
	P2,P17	C	0°
	P3,P16	D	0° OR 90°
	P5,P14	E	0° OR 90°

PLY TABLE **F**

DETAIL VI



ITEM NO.	PLY NO.	MATERIAL	PLY ORIENTATION A
4	P1 N	B	0° OR 90°
	P1 O	K	
	P2 THRU P11	I	0° OR 90°
	P12	H	0° OR 90°

PLY TABLE **F**

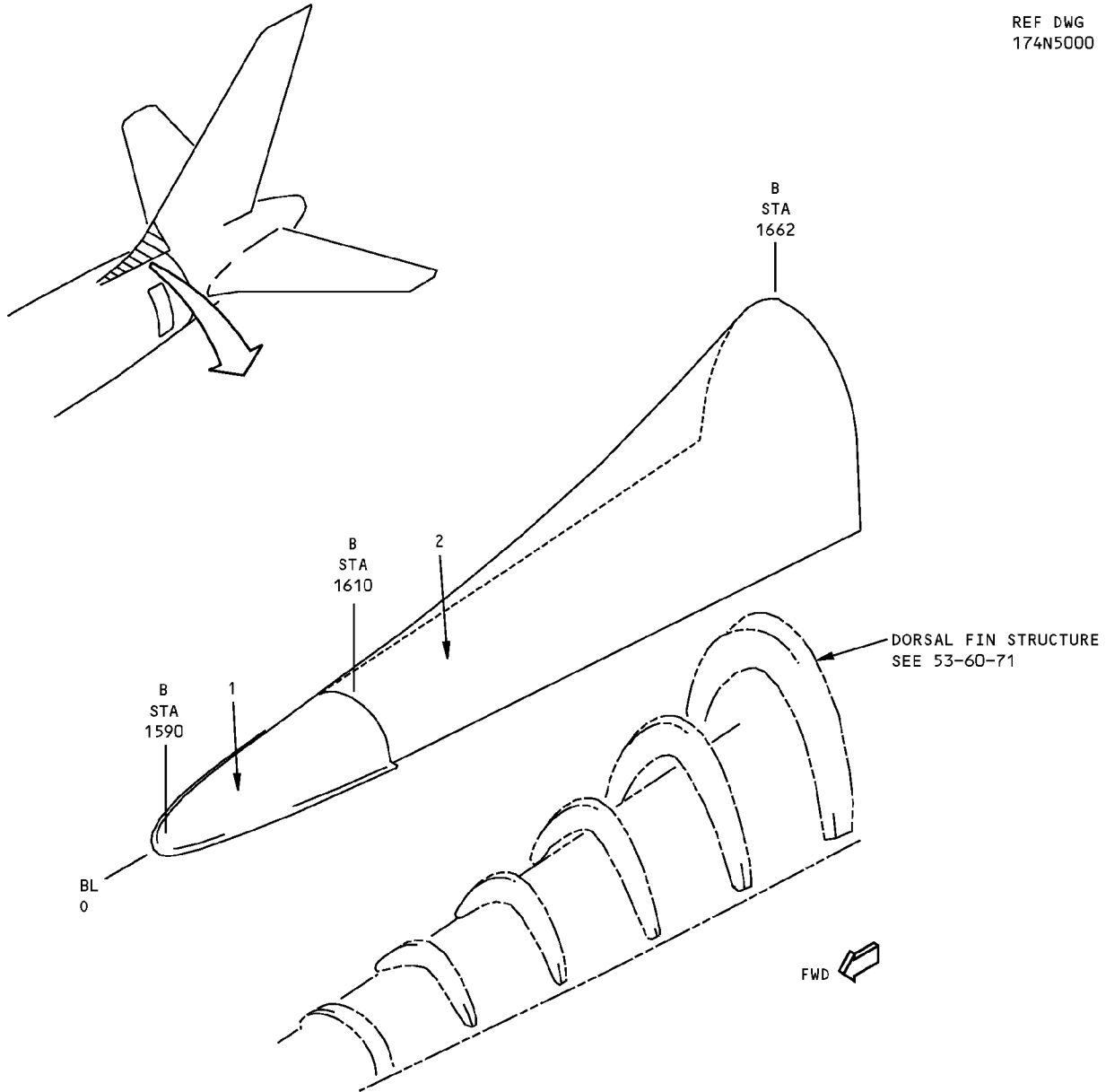
DETAIL VII

**Section 46 Wing-To-Body Fairing Skin Identification
Figure 1 (Sheet 8 of 8)**

**757-200
STRUCTURAL REPAIR MANUAL**

IDENTIFICATION 2 - DORSAL FIN SKIN

REF DWG
174N5000



ITEM	DESCRIPTION	GAGE	MATERIAL	EFFECTIVITY
1	SKIN	0.050	CLAD 2024-T42	
2	SKIN	0.090	CLAD 2024-T42	

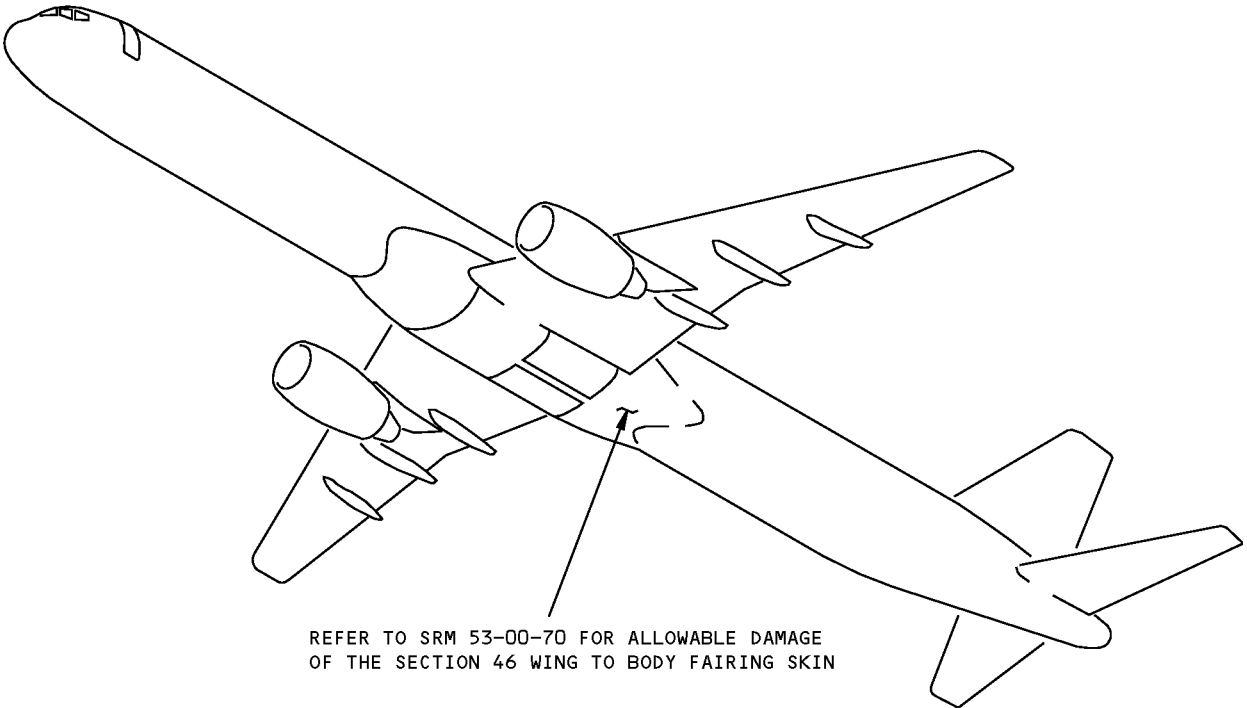
LIST OF MATERIALS

**Dorsal Fin Skin Identification
Figure 1**



757-200
STRUCTURAL REPAIR MANUAL

ALLOWABLE DAMAGE GENERAL - SECTION 46 - WING-TO-BODY FAIRING SKINS



Section 46 Wing-to-Body Fairing Skin Allowable Damage
Figure 101

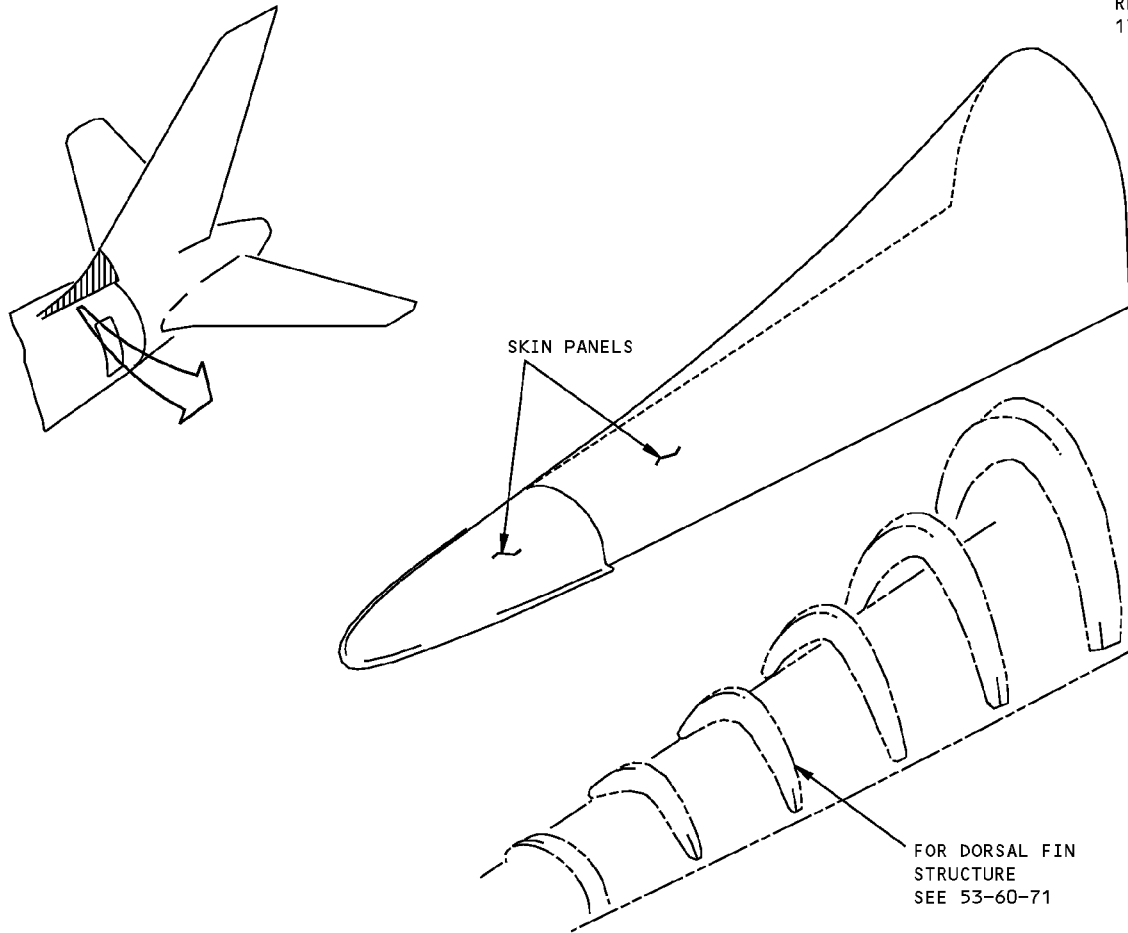
D634N201

ALLOWABLE DAMAGE GENERAL
53-60-70
Page 101
Jan 20/2005

**757-200
STRUCTURAL REPAIR MANUAL**

ALLOWABLE DAMAGE 1 - DORSAL FIN SKIN

REF DWG
174N5000



MATERIAL: ALUMINUM

DESCRIPTION	CRACKS	NICKS, GOUGES AND CORROSION	DENTS	HOLES AND PUNCTURES
SKIN PANEL	A	B	SEE DETAIL III	C

NOTES

- REFINISH REWORKED AREAS PER 51-20 OF THE MAINTENANCE MANUAL
- REFER TO 51-10-01 FOR AERODYNAMIC SMOOTHNESS REQUIREMENTS. WHERE THE DAMAGE EXCEEDS THE LIMITS SHOWN IN 51-10-01, CONSIDERATION SHOULD BE GIVEN TO THE LOSS OF PERFORMANCE INVOLVED

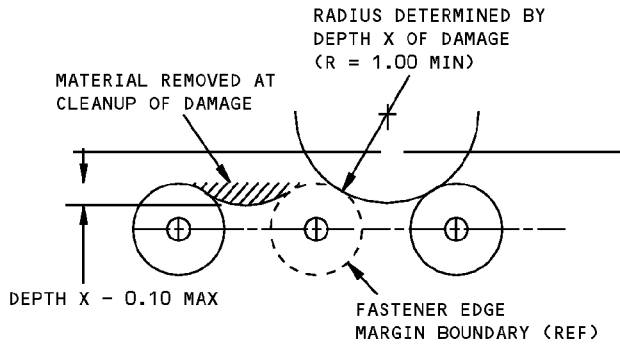
B REMOVE DAMAGE PER DETAILS I, II AND IV

C CLEAN OUT DAMAGE UP TO 0.25 MAX DIA AND NOT CLOSER THAN 1.0 INCH TO FASTENER HOLE, MATERIAL EDGE, OR OTHER DAMAGE. FILL HOLE WITH 2117-T3 OR T4 ALUMINUM RIVET INSTALLED WET WITH BMS 5-95 SEALANT. ALL OTHER HOLES TO BE REPAIRED

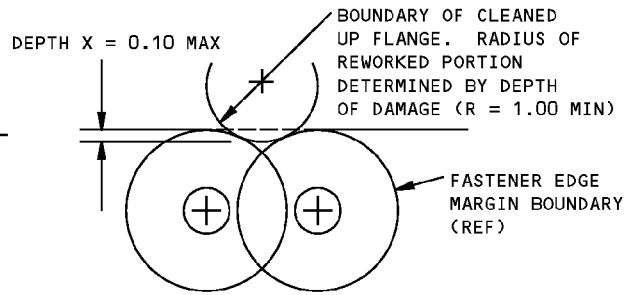
A REMOVE EDGE CRACKS PER DETAIL I. FOR OTHER CRACKS UP TO 0.25 SEE **C**

**Dorsal Fin Skin Allowable Damage
Figure 101 (Sheet 1 of 2)**

STRUCTURAL REPAIR MANUAL

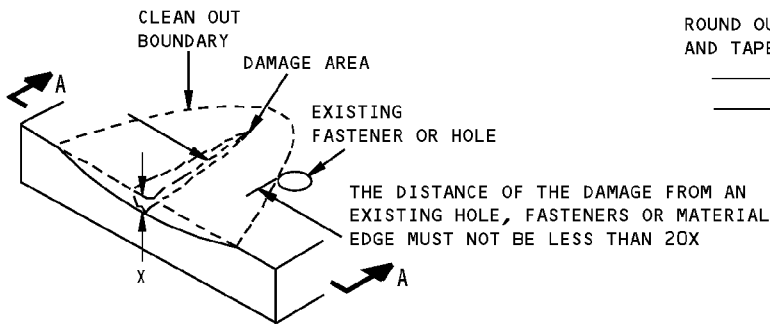


DAMAGE CLEANUP OF EDGES WHERE FASTENER EDGE MARGINS DO NOT OVERLAP

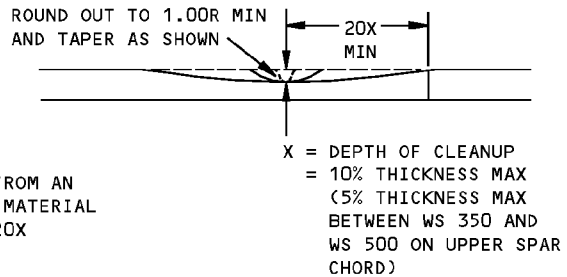


DAMAGE CLEANUP OF EDGES WHERE FASTENER EDGE MARGINS OVERLAP

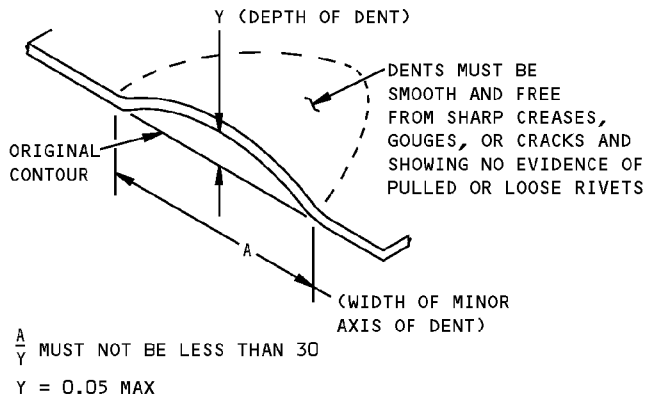
DETAIL I



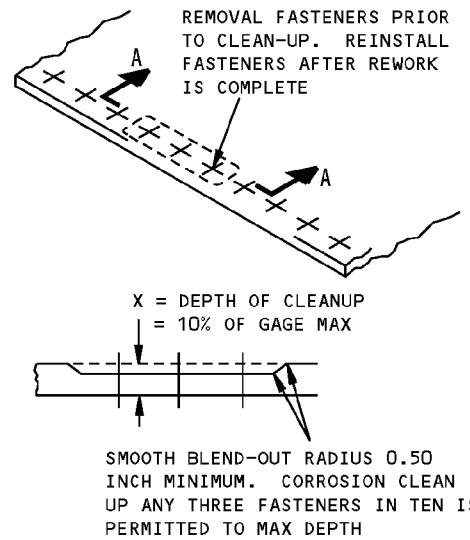
REMOVAL OF NICK, GOUGE AND SCRATCH DAMAGE ON A SURFACE
DETAIL II



SECTION A-A



ALLOWABLE DAMAGE FOR DENT
DETAIL III



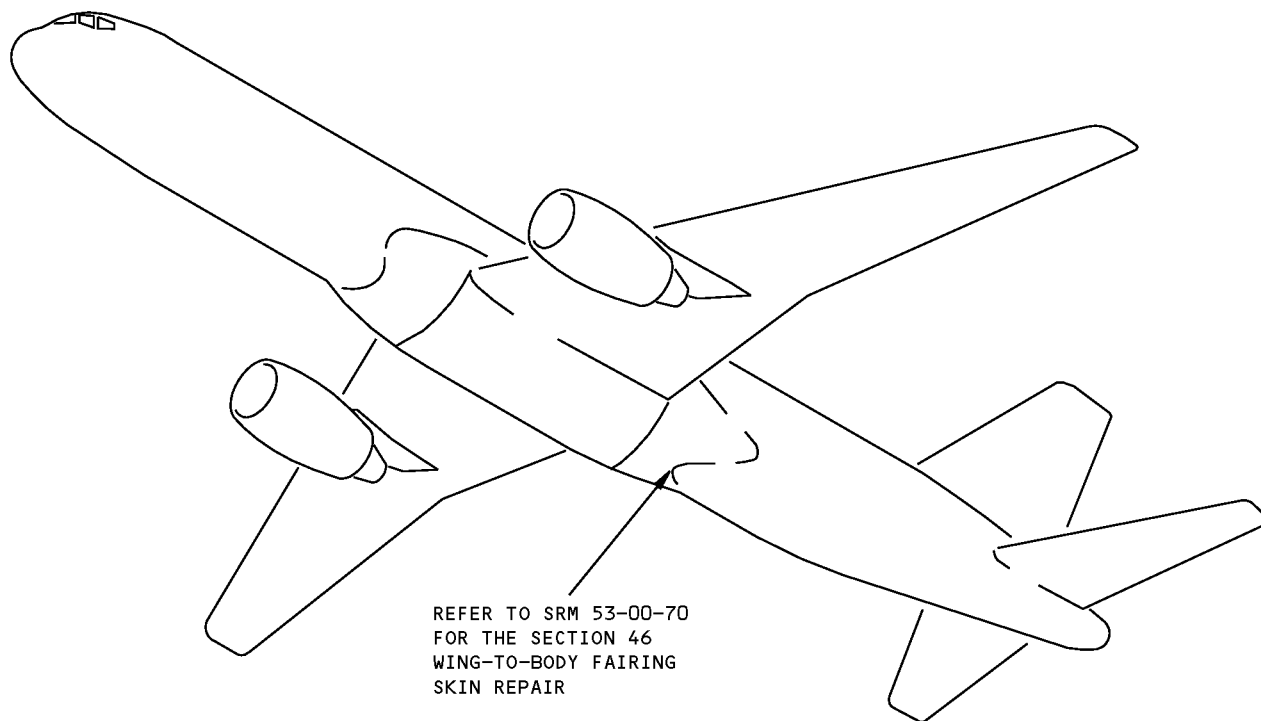
SECTION B-B
CORROSION CLEANUP
DETAIL IV

**Dorsal Fin Skin Allowable Damage
Figure 101 (Sheet 2 of 2)**



757-200
STRUCTURAL REPAIR MANUAL

REPAIR GENERAL - SECTION 46 WING TO BODY FAIRING SKIN REPAIRS



Section 46 Wing to Body Fairing Skin Repairs
Figure 201

D634N201

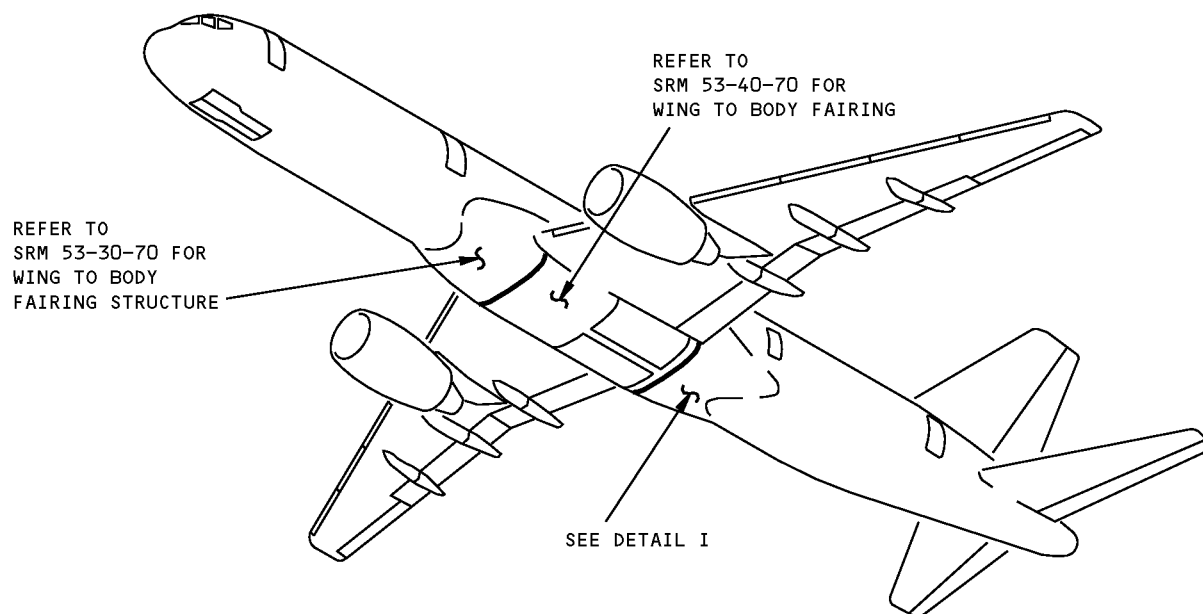
53-60-70

REPAIR GENERAL
Page 201
Jan 20/2005



757-200
STRUCTURAL REPAIR MANUAL

IDENTIFICATION 1 - SECTION 46 - WING-TO-BODY FAIRING STRUCTURE



NOTES

- A** FIBERGLASS/EPOXY FABRIC AS GIVEN IN BMS 8-79,
STYLE 120, CLASS III
- B** FIBERGLASS/EPOXY FABRIC AS GIVEN IN BMS 8-79,
STYLE 1581, CLASS III

Section 46 Wing-to-Body Fairing Structure Identification
Figure 1 (Sheet 1 of 5)



**757-200
STRUCTURAL REPAIR MANUAL**

ITEM	DESCRIPTION	GAGE	MATERIAL	EFFECTIVITY
1	BEAM WEB LOWER CHORD	0.063	7075-T6 BAC1505-100403 7075-T6	
2	BEAM WEB LOWER CHORD	0.063	7075-T6 BAC1505-100361 7075-T6	
3	FRAME WEB OUTER CHORD	0.040	CLAD 7075-T6 BAC1505-100886 7075-T6	
4	FRAME WEB OUTER CHORD	0.063	7075-T6 BAC1505-100403 7075-T6	
5	STRUT		AND10136-1501 7075-T6511	
6	CHANNEL	0.080	7075-T6	
7	CHANNEL	0.063	7075-T6	
8	FRAME	0.063	7075-T6	
9	FRAME WEB OUTER CHORD	0.063	CLAD 2024-T42 BAC1505-100886 7075-T6	
10	STIFFENER		AND10136-2004 7075-T6511	
11	STIFFENER		AND10136-1401 7075-T6511	
12	PANEL	0.050	CLAD 7075-T6	
13	STIFFENER	0.050	CLAD 7075-T6	
14	INTERCOSTAL WEB CHORD	0.063	CLAD 7075-T6 BAC1505-100886 7075-T6	
15	CHORD	0.063	CLAD 7075-T6	

LIST OF MATERIALS FOR DETAIL I

**Section 46 Wing-to-Body Fairing Structure Identification
Figure 1 (Sheet 3 of 5)**

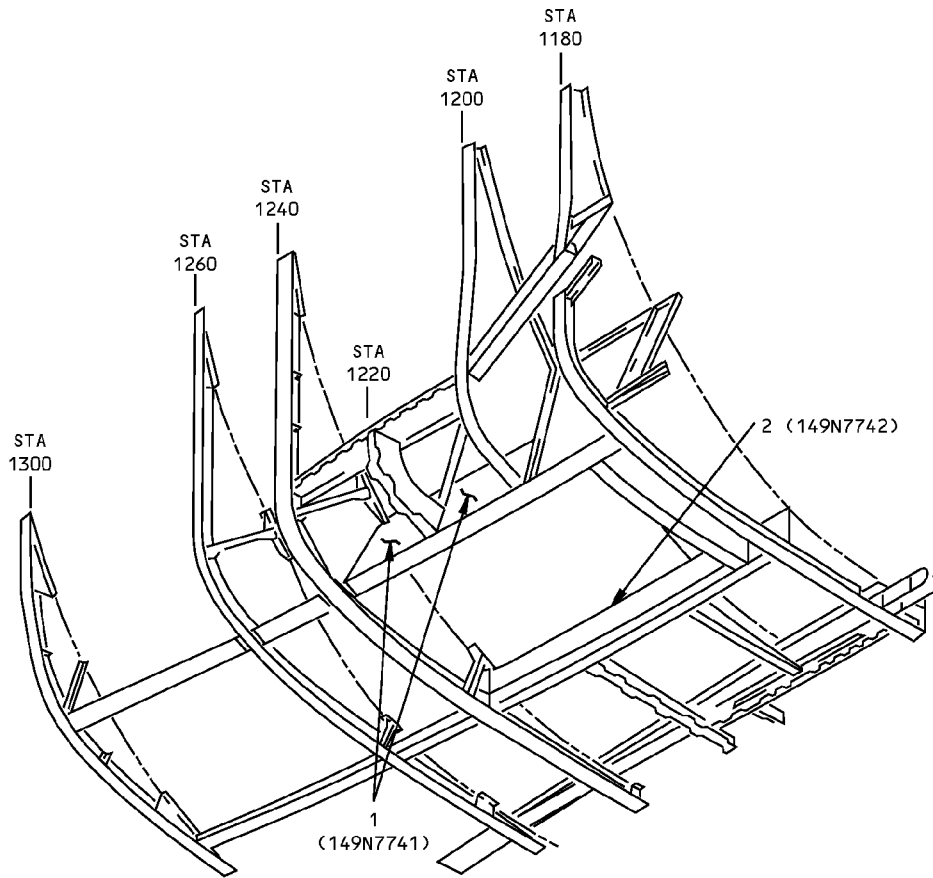
IDENTIFICATION 1
Page 3
Jan 20/2005

53-60-71

D634N201

**757-200
STRUCTURAL REPAIR MANUAL**

REF DWG
149N7741
149N7742



RIGHT SIDE ONLY
DETAIL II

ITEM	DESCRIPTION	GAGE	MATERIAL	EFFECTIVITY
1	SKIN PANEL SKIN CORE		FIBERGLASS/EPOXY HONEYCOMB SANDWICH SEE DETAIL III NOMEX HONEYCOMB PER BMS 8-124, CLASS IV, TYPE V, GRADE 3.0	
2	SKIN PANEL SKIN CORE		FIBERGLASS/EPOXY HONEYCOMB SANDWICH SEE DETAIL IV NOMEX HONEYCOMB PER BMS 8-124, CLASS IV, TYPE V, GRADE 3.0	

LIST OF MATERIALS FOR DETAIL II

**Section 46 Wing-to-Body Fairing Structure Identification
Figure 1 (Sheet 4 of 5)**

IDENTIFICATION 1
Page 4
Jan 20/2005

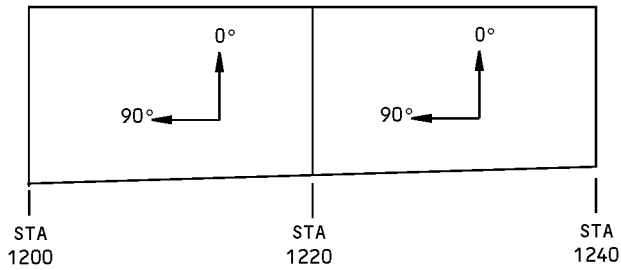
53-60-71

D634N201

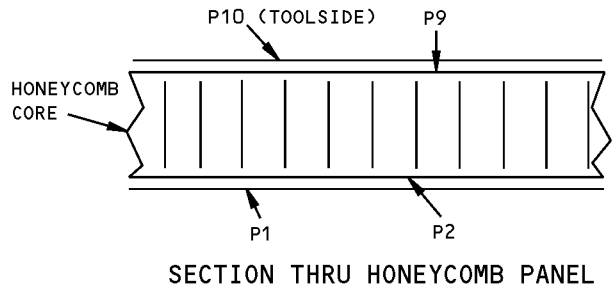
**757-200
STRUCTURAL REPAIR MANUAL**

ITEM NO.	PLY NO.	MATERIAL	PLY ORIENTATION
1	P1,P10	A	0° OR 90°
	P2,P9	B	0° OR 90°

PLY TABLE FOR DETAIL III



PLY ORIENTATION DIAGRAM

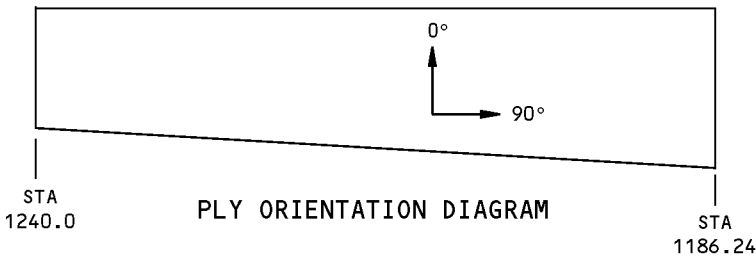


SECTION THRU HONEYCOMB PANEL

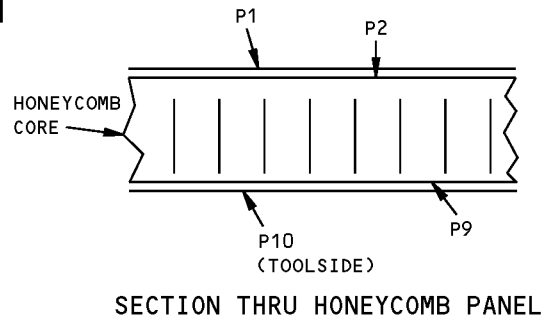
DETAIL III

ITEM NO.	PLY NO.	MATERIAL	PLY ORIENTATION
2	P1,P2 P9,P10	A	0° OR 90°

PLY TABLE FOR DETAIL IV



PLY ORIENTATION DIAGRAM



SECTION THRU HONEYCOMB PANEL

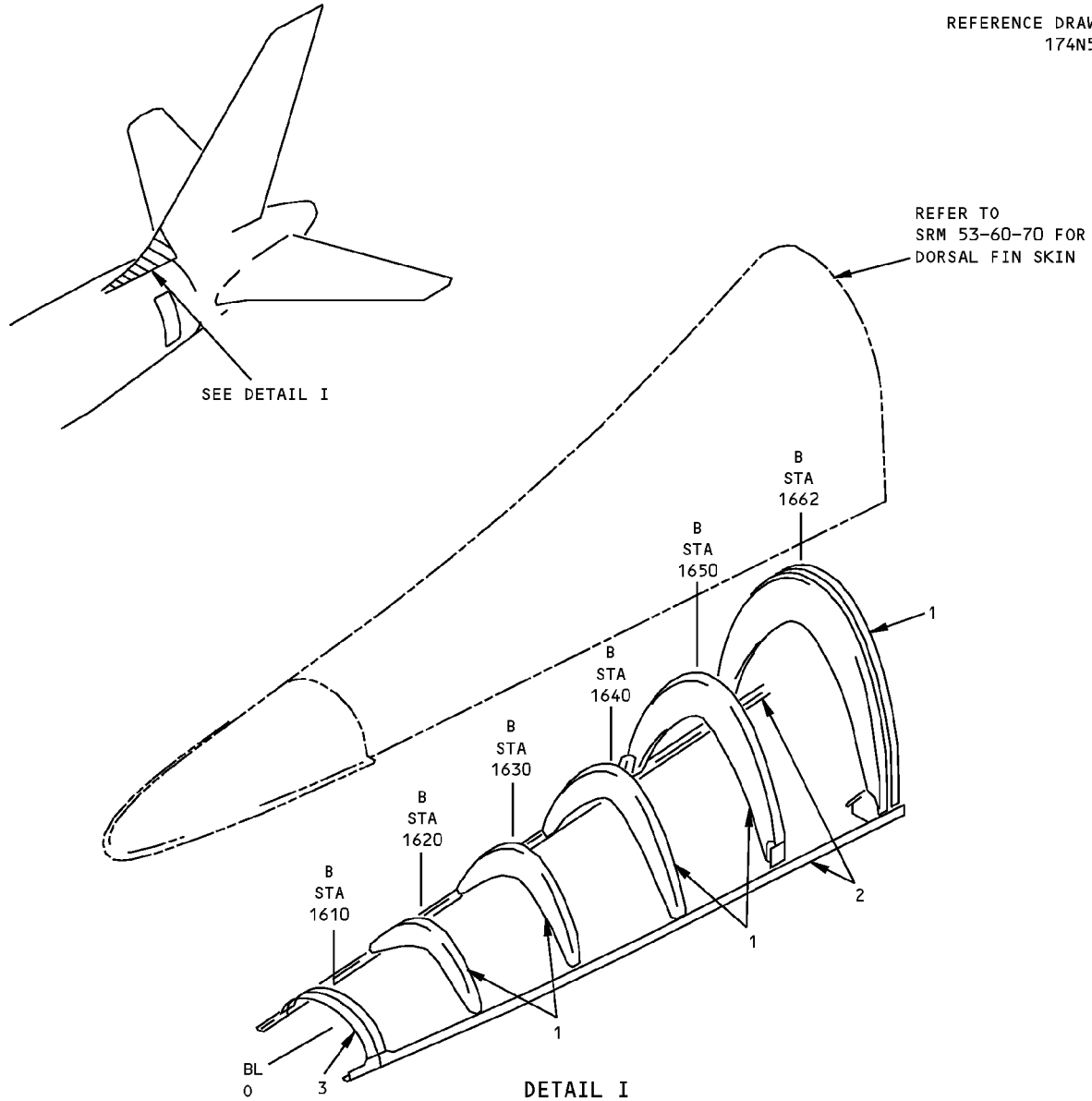
DETAIL IV

**Section 46 Wing-to-Body Fairing Structure Identification
Figure 1 (Sheet 5 of 5)**

**757-200
STRUCTURAL REPAIR MANUAL**

IDENTIFICATION 2 - DORSAL FIN STRUCTURE

REFERENCE DRAWING
174N5000



ITEM	DESCRIPTION	GAGE	MATERIAL	EFFECTIVITY
1	FRAME	0.050	CLAD 7075-T6	
2	ANGLE	0.063	CLAD 7075-T6	
3	STRAP	0.050	CLAD 2024-T42	

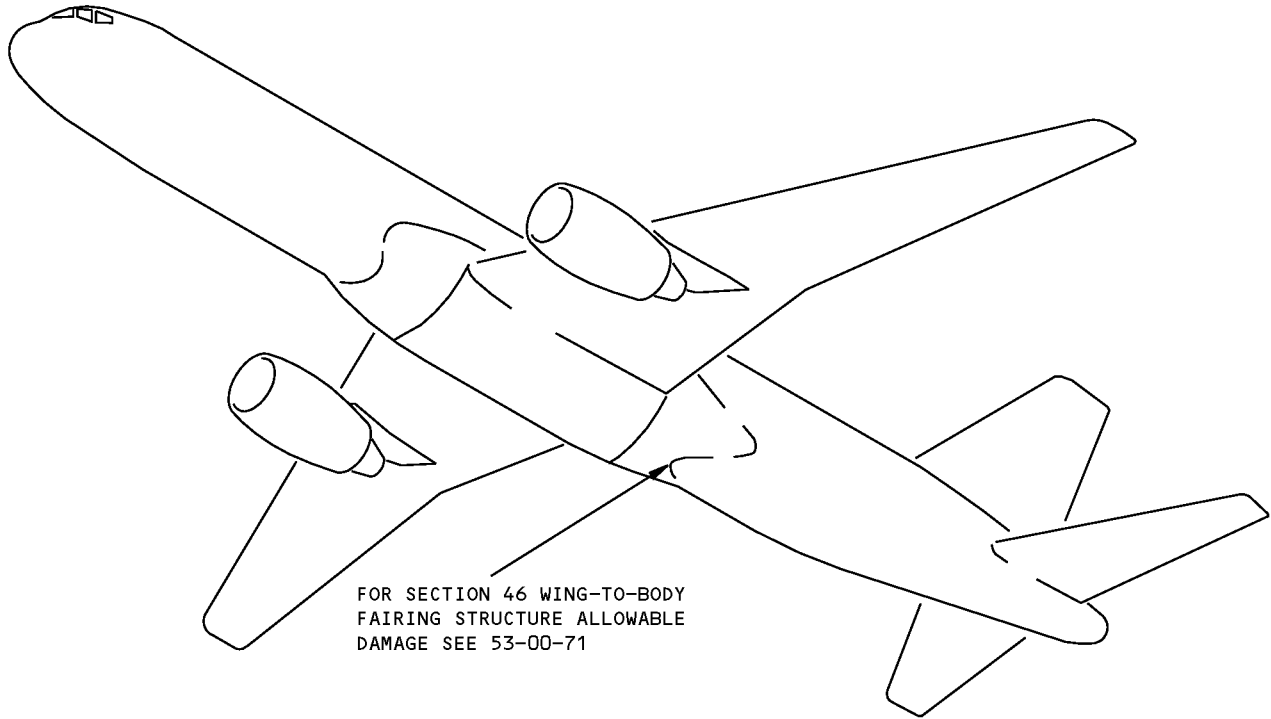
LIST OF MATERIALS
FOR DETAIL I

**Dorsal Fin Structure Identification
Figure 1**



**757-200
STRUCTURAL REPAIR MANUAL**

ALLOWABLE DAMAGE GENERAL - SECTION 46 WING-TO-BODY FAIRING STRUCTURE



**Section 46 Wing-to-Body Fairing Structure Allowable Damage
Figure 101**

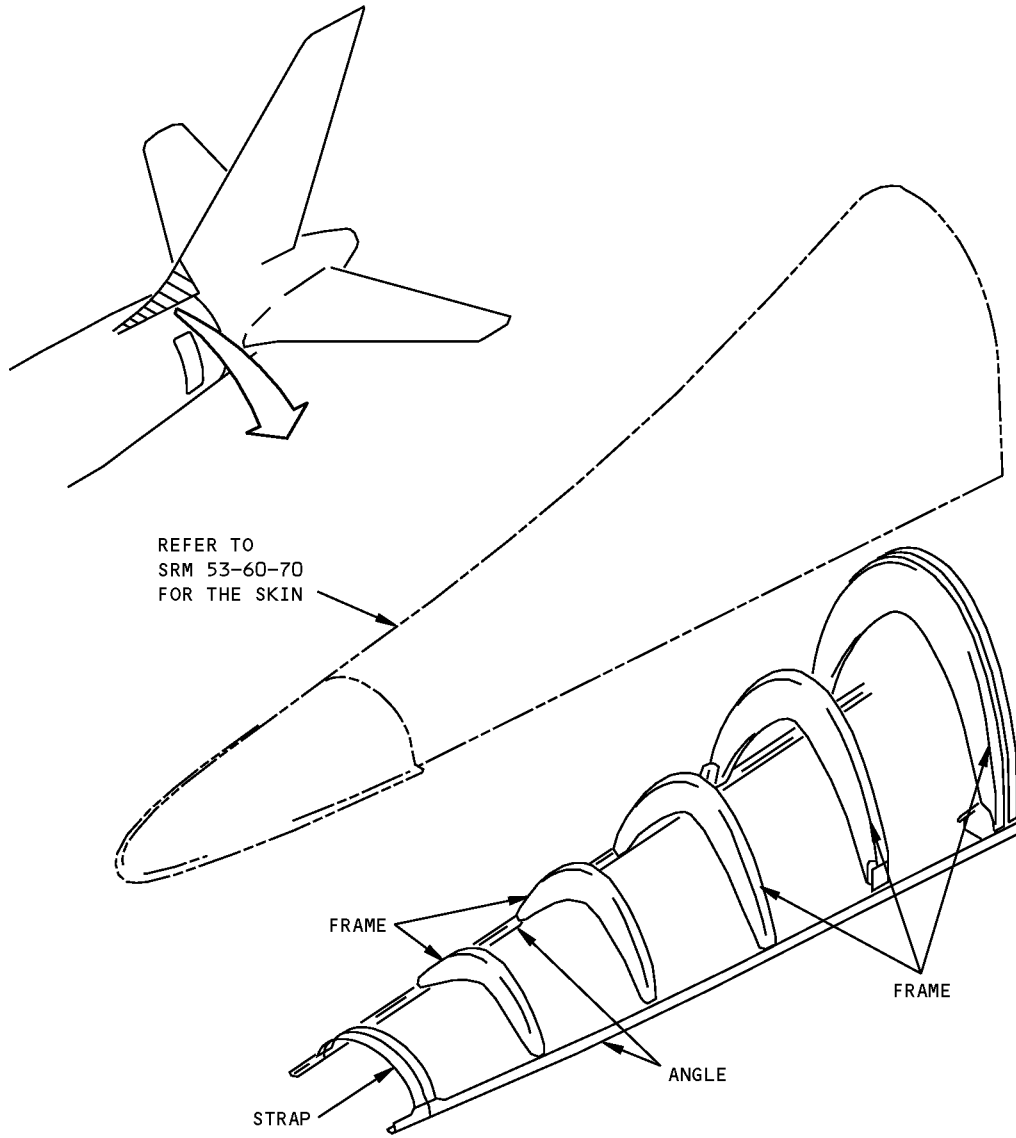
D634N201

ALLOWABLE DAMAGE GENERAL
53-60-71
Page 101
Jan 20/2005

**757-200
STRUCTURAL REPAIR MANUAL**

ALLOWABLE DAMAGE 1 - DORSAL FIN STRUCTURE - SECTION 46

REFERENCE DRAWING
174N5000



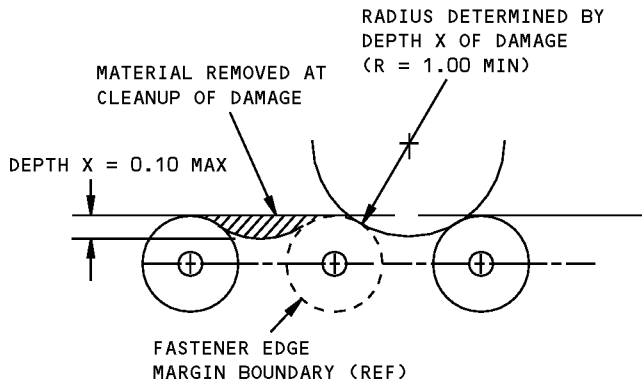
DESCRIPTION	CRACKS	NICKS, GOUGES AND CORROSION	DENTS	HOLES AND PUNCTURES
FRAME	A	B	SEE DETAIL III	C
ANGLE	A	B	NOT PERMITTED	C
STRAP	A	B	NOT PERMITTED	NOT PERMITTED

**Dorsal Fin Structure - Section 46 - Allowable Damage
Figure 101 (Sheet 1 of 3)**

**757-200
STRUCTURAL REPAIR MANUAL**

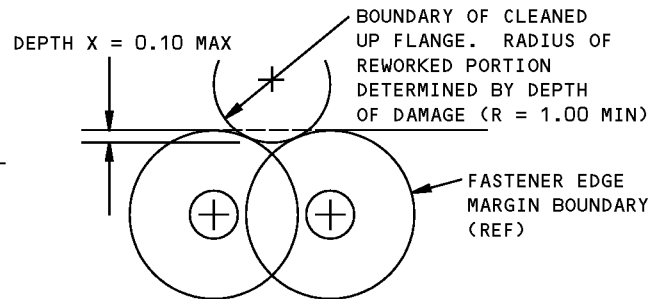
NOTES

- REFINISH REWORKED AREAS PER 51-20 OF THE MAINTENANCE MANUAL
- A** CRACKS NOT ALLOWED EXCEPT FOR EDGE CRACKS WHICH MUST BE REMOVED PER DETAILS I AND IV
- B** REMOVED DAMAGE PER DETAILS I, II, IV AND V
- C** CLEAN OUT DAMAGE UP TO 0.25 MAX DIA AND NOT CLOSER THAN 1.0 INCH TO FASTENER HOLE OR OTHER DAMAGE. FILL HOLE WITH A 2117-T3 OR T4 ALUMINUM RIVET INSTALLED WET WITH BMS 5-95 SEALANT. ALL OTHER HOLES TO BE REPAIRED. MAINTAIN 2.0 D EDGE MARGIN.

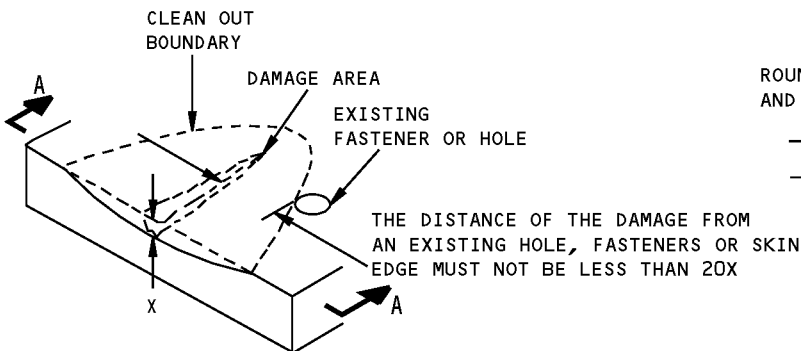


**DAMAGE CLEANUP OF EDGES WHERE
FASTENER EDGE MARGINS DO NOT OVERLAP**

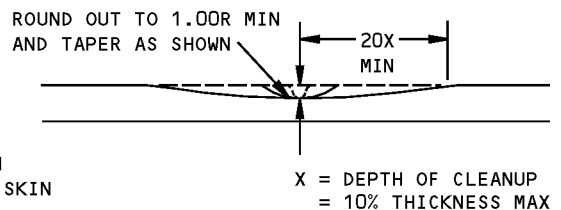
DETAIL I



**DAMAGE CLEANUP OF EDGES WHERE
FASTENER EDGE MARGINS OVERLAP**



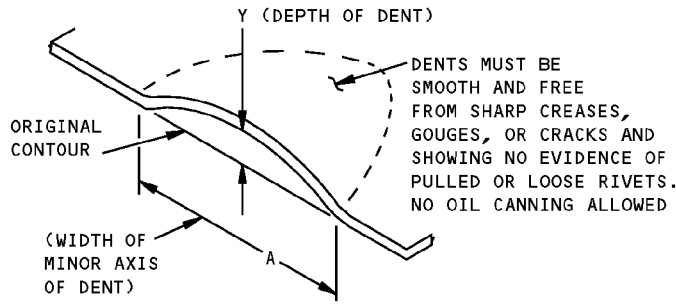
**REMOVAL OF NICK, GOUGE AND SCRATCH DAMAGE ON A SURFACE
DETAIL II**



SECTION A-A

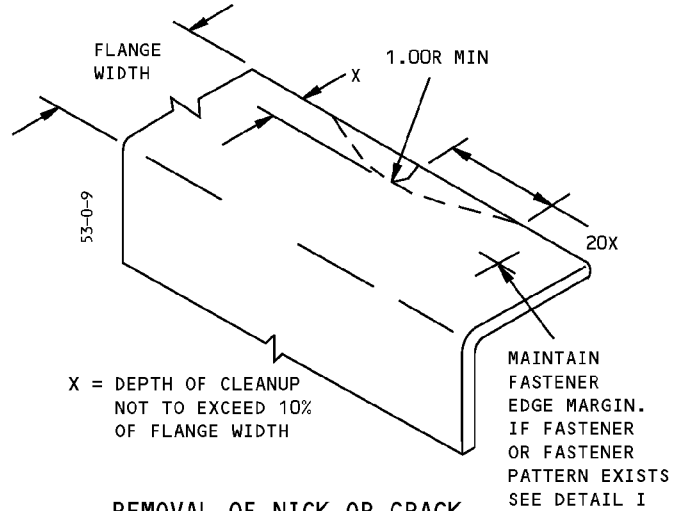
**Dorsal Fin Structure - Section 46 - Allowable Damage
Figure 101 (Sheet 2 of 3)**

STRUCTURAL REPAIR MANUAL

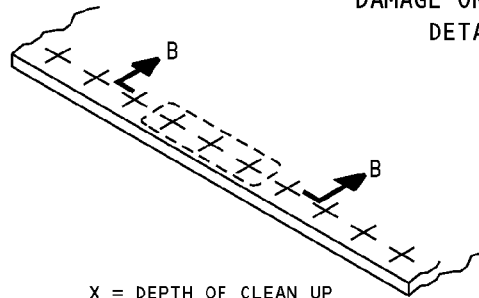


$\frac{A}{Y}$ MUST NOT BE LESS THAN 30
 Y MAX = 0.05

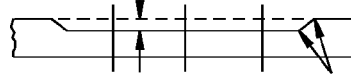
ALLOWABLE DAMAGE FOR DENT (WEB ONLY)
 DETAIL III



REMOVAL OF NICK OR CRACK
 DAMAGE ON AN EDGE
 DETAIL IV



X = DEPTH OF CLEAN UP
 DEPTH X MUST NOT EXCEED
 10% OF MATERIAL THICKNESS



SMOOTH BLEND-OUT RADIUS 0.50 INCH
 MINIMUM. CORROSION CLEANUP AROUND
 ANY THREE FASTENERS IN TEN IS
 PERMITTED TO MAX DEPTH

SECTION B-B

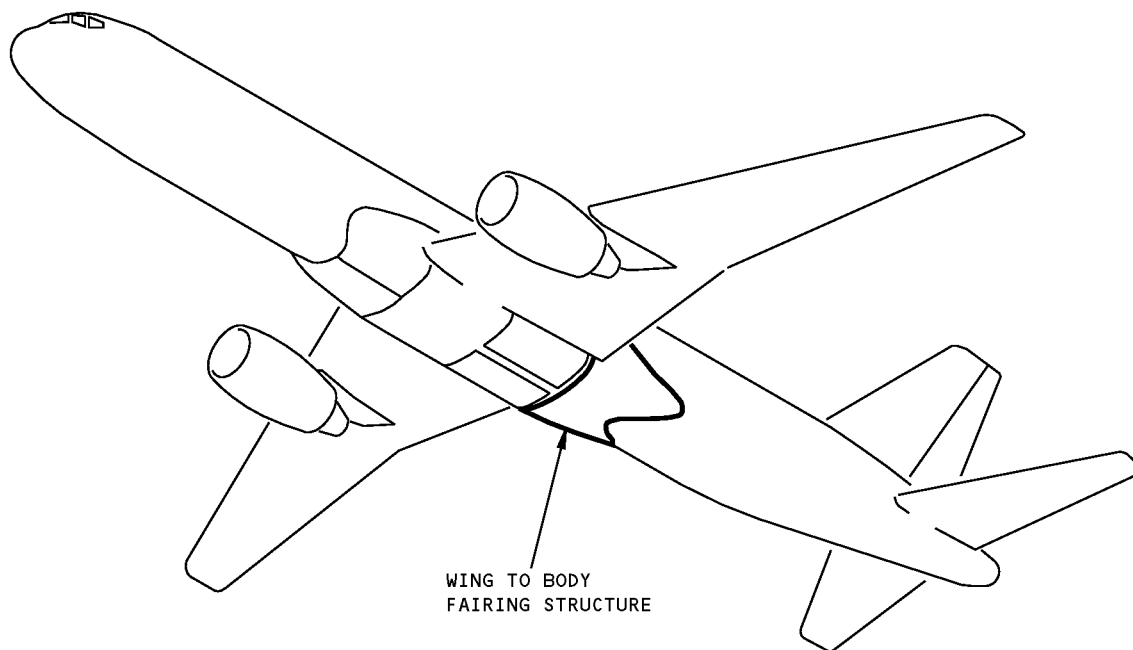
CORROSION CLEANUP
 DETAIL V

Dorsal Fin Structure - Section 46 - Allowable Damage
 Figure 101 (Sheet 3 of 3)



757-200
STRUCTURAL REPAIR MANUAL

REPAIR GENERAL - SECTION 46 - WING-TO-BODY FAIRING STRUCTURE



NOTES

- REFER TO SRM 51-70-11 FOR FORMED SECTION REPAIR
- REFER TO SRM 51-70-12 FOR EXTRUDED SECTION REPAIR
- REFER TO SRM 51-70-13 FOR WEB REPAIRS

Section 46 Wing-to -Body Fairing Structure Repair
Figure 201

D634N201

53-60-71

REPAIR GENERAL
Page 201
Jan 20/2005

**757-200
STRUCTURAL REPAIR MANUAL**

REPAIR 1 - SECTION 46 - WING-TO-BODY FAIRING - FRAME SUPPORT ANGLE

APPLICABILITY
THIS REPAIR IS APPLICABLE TO THE SUPPORT ANGLE AT STRINGERS S-25 OR S-21 ON THE WING TO BODY FAIRING FRAME AT STATION 1300.

REPAIR INSTRUCTIONS





1. Get access to the damaged area.
2. Cut and remove the damaged part of the angle. Make the corners of the cutout at least 0.25 inch (6 mm) radius.
3. Do a penetrant inspection to make sure that there are no cracks after the damage is removed. Refer to SOPM 20-20-02.
4. Make the repair parts. See Table I. Make the corners of the repair parts at least 0.25 inch (6 mm) radius.
5. Assemble the repair parts and drill the fastener holes.
6. Disassemble the repair parts.
7. Remove the nicks, scratches, gouges, burrs, and sharp edges from the repair parts and the support angle.
8. Apply a chemical conversion coating to the repair parts and to the bare surfaces of the support angle. Refer to SRM 51-20-01.
9. Apply one layer of BMS 10-11, Type I primer to the repair parts and to the bare surfaces of the angle. Refer to SOPM 20-41-02.
10. Install the repair parts with BMS 5-95 sealant between the mating surfaces.
11. Install the fasteners. Fasteners that are not made of aluminum must be installed wet with BMS 5-95 sealant.
12. Apply one layer of BMS 10-11, Type II finish to the repair area. Refer to SOPM 20-41-02.

NOTES

- D = FASTENER DIAMETER
- KEEP A DISTANCE OF 4D TO 6D BETWEEN THE FASTENERS.
- KEEP FASTENER EDGE DISTANCE TO A MINIMUM OF 2D.
- KEEP GAPS TO 0.005 INCH (0.127 mm) OR LESS. USE 2024-T3 CLAD OR 7075-T6 CLAD FILLERS OR LAMINATED SHIM STOCK.

- WHEN YOU USE THIS REPAIR REFER TO:
 - SOPM 20-20-02 FOR PENETRANT INSPECTION
 - SOPM 20-41-02 FOR APPLICATION OF FINISHES
 - SRM 51-10-02 FOR INSPECTION AND REMOVAL OF DAMAGE
 - SRM 51-20-01 FOR PROTECTIVE TREATMENT OF METALLIC AND GRAPHITE MATERIALS
 - SRM 51-20-05 FOR REPAIR SEALING
 - SRM 51-40 FOR FASTENER CODE, INSTALLATION AND REMOVAL, HOLE SIZES AND EDGE MARGINS.

FASTENER SYMBOLS

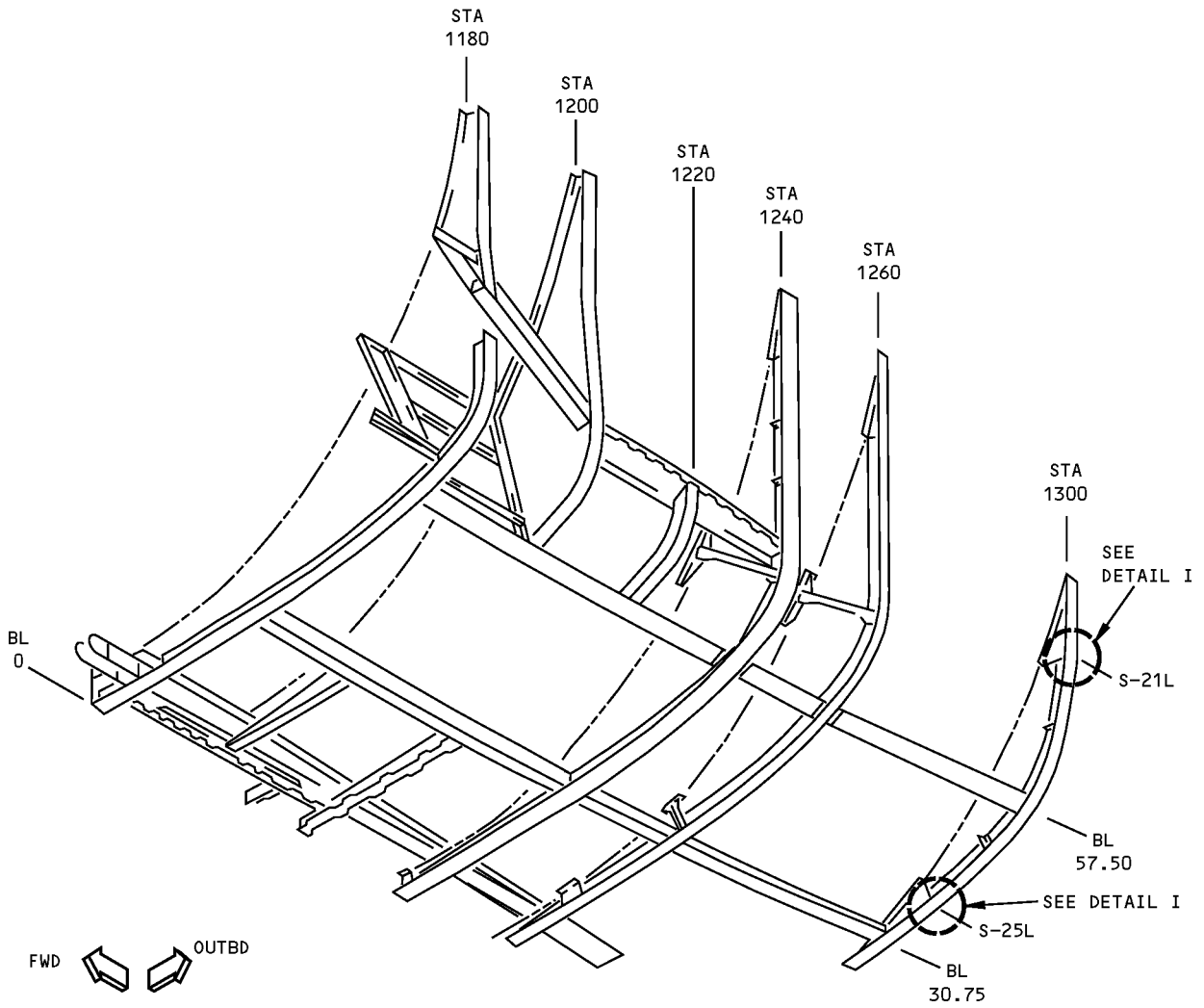
-  REFERENCE FASTENER LOCATION.
-  REPAIR FASTENER LOCATION. INSTALL A BACR15FT6D() RIVET.
-  INITIAL FASTENER LOCATION. INSTALL A BACR15FT6D() RIVET. (UP TO 1/32-INCH DIAMETER OVERSIZE).
-  INITIAL FASTENER LOCATION. INSTALL A BACB30MY6K()X HEX DRIVE BOLT WITH A BACC30M6 COLLAR.

REPAIR MATERIAL			
	PART	QTY	MATERIAL
1	ANGLE	1	0.071 INCH 7075-0 HT TR T6
2	FILLER	1	0.063 INCH 7075-T6

TABLE I

**Section 46 - Wing-to-Body Fairing - Frame Support Angle Repair
Figure 201 (Sheet 1 of 3)**

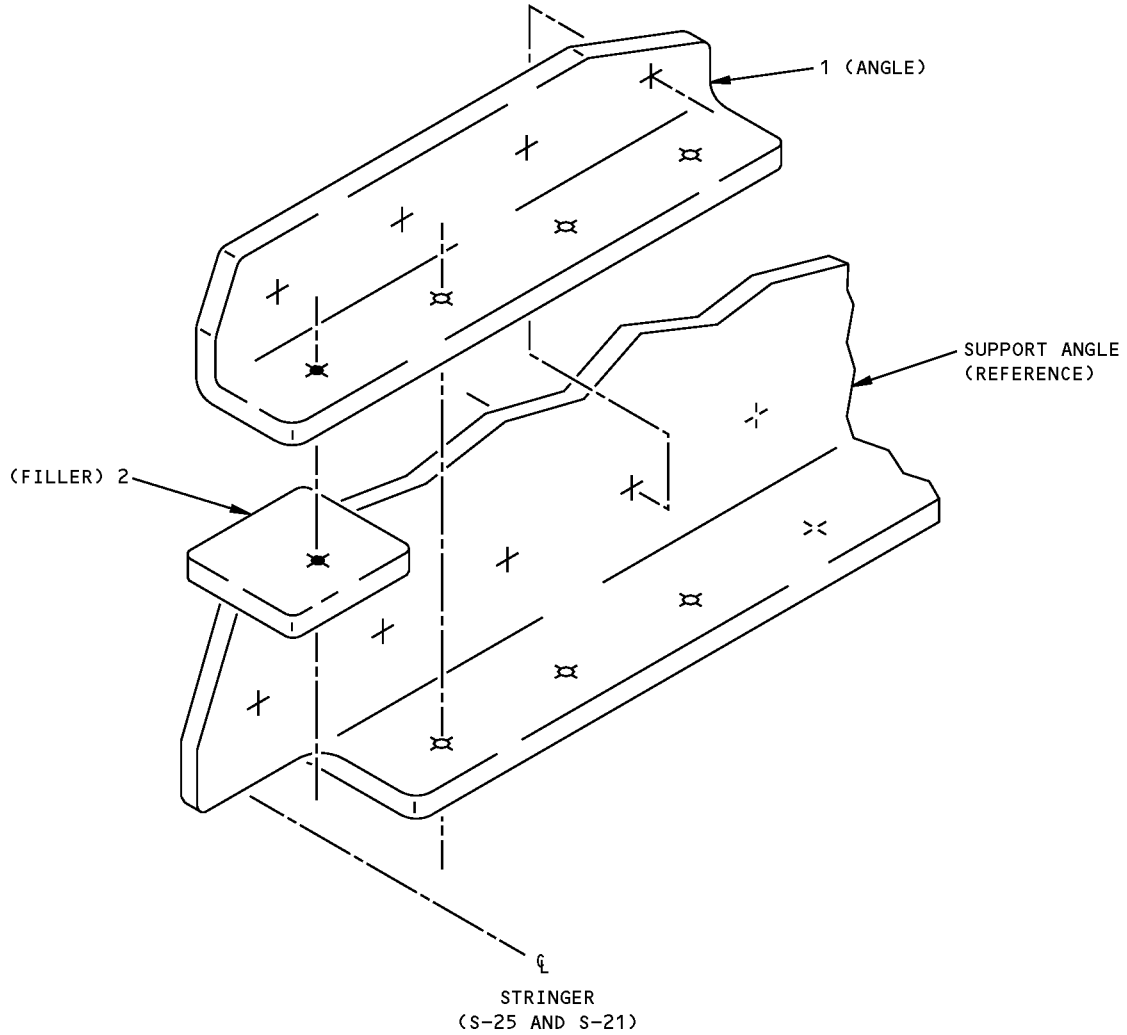
**757-200
STRUCTURAL REPAIR MANUAL**



LEFT SIDE SHOWN
RIGHT SIDE OPPOSITE

**Section 46 - Wing-to-Body Fairing - Frame Support Angle Repair
Figure 201 (Sheet 2 of 3)**

**757-200
STRUCTURAL REPAIR MANUAL**

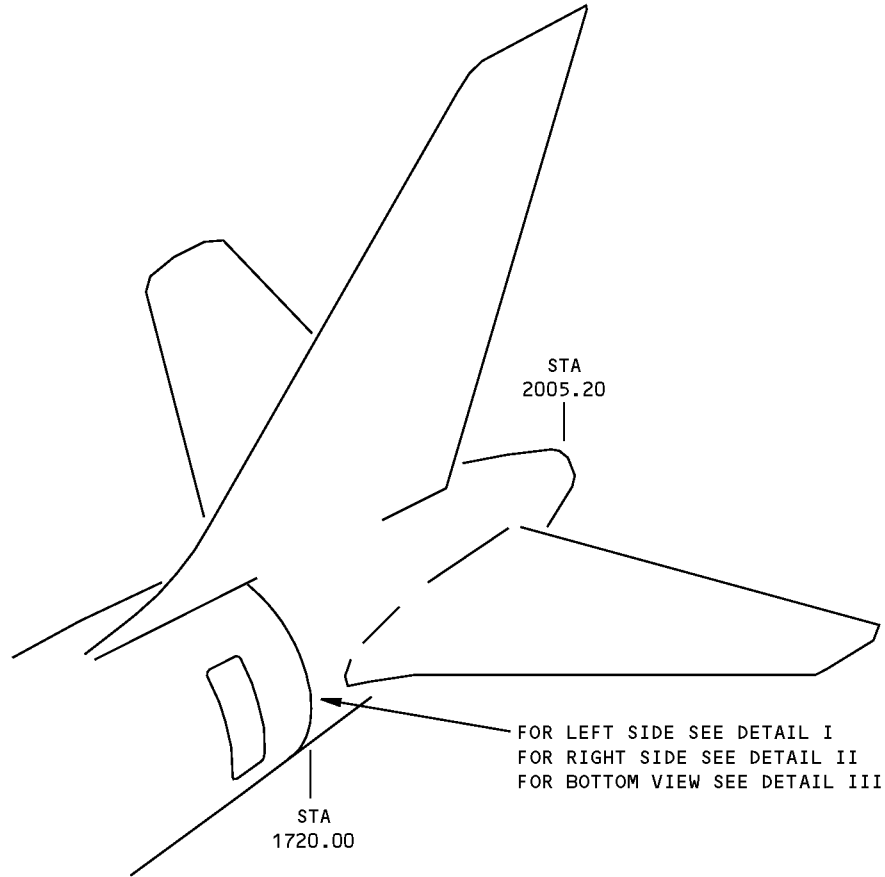


DETAIL I

**Section 46 - Wing-to-Body Fairing - Frame Support Angle Repair
Figure 201 (Sheet 3 of 3)**

757-200
STRUCTURAL REPAIR MANUAL

IDENTIFICATION 1 - SECTION 48 - SKINS



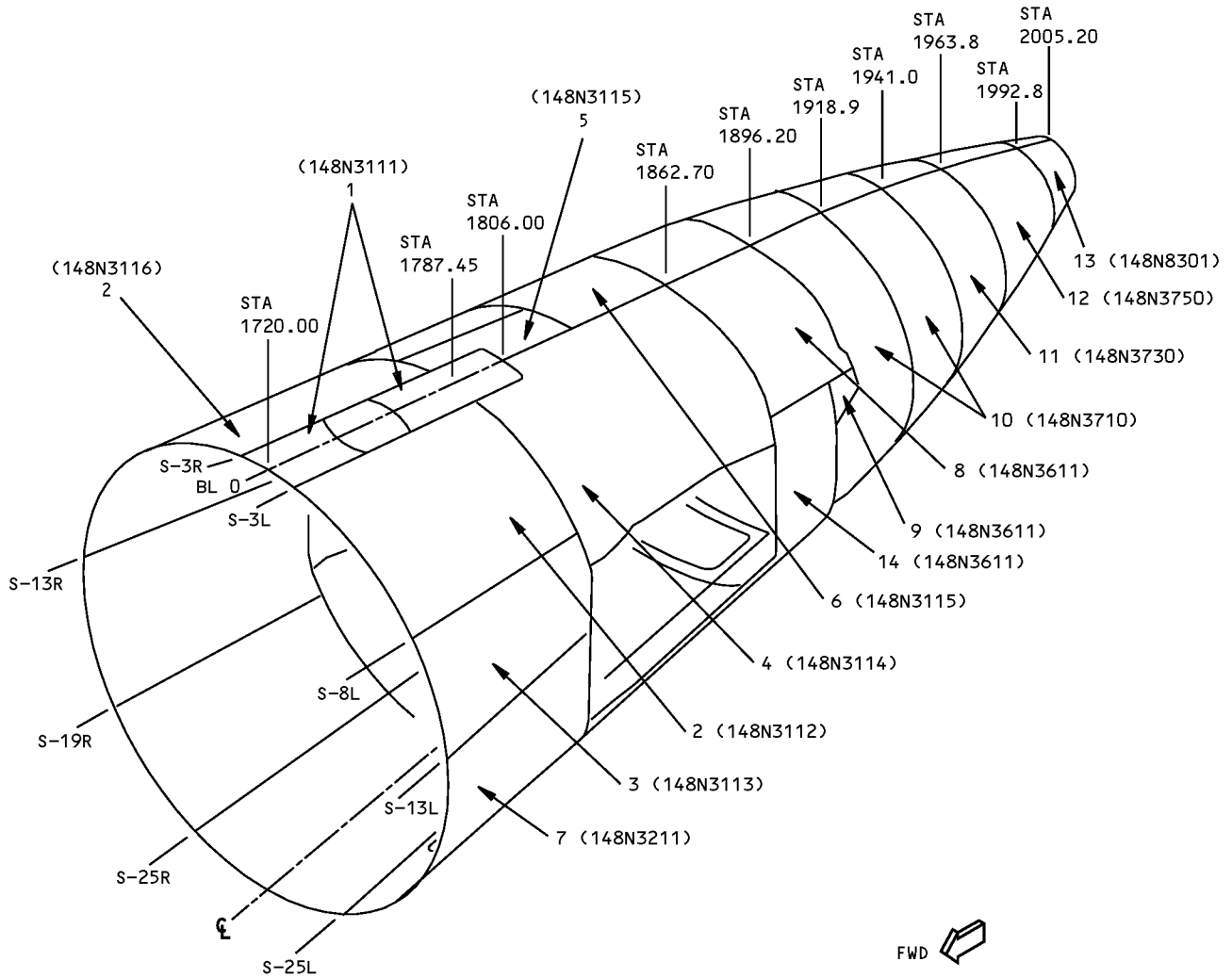
NOTES

- A** FOR CUM LINE NUMBERS:
1 THRU 37
- B** FOR AIRPLANES WITH CUM LINE NUMBERS
38 AND ON, AND AIRPLANES WITH SERVICE
BULLETIN 757-53-0015 INCORPORATED.
- C** FOR AIRPLANES WITH SERVICE BULLETIN
757-53-0064 INCORPORATED.

Section 48 Skin Identification
Figure 1 (Sheet 1 of 7)

**757-200
STRUCTURAL REPAIR MANUAL**

REF DWG
148N0006



LEFT SIDE
DETAIL I

LIST OF
MATL

Section 48 Skin Identification
Figure 1 (Sheet 2 of 7)

IDENTIFICATION 1
Page 2
Jan 20/2005

53-80-01

D634N201



**757-200
STRUCTURAL REPAIR MANUAL**

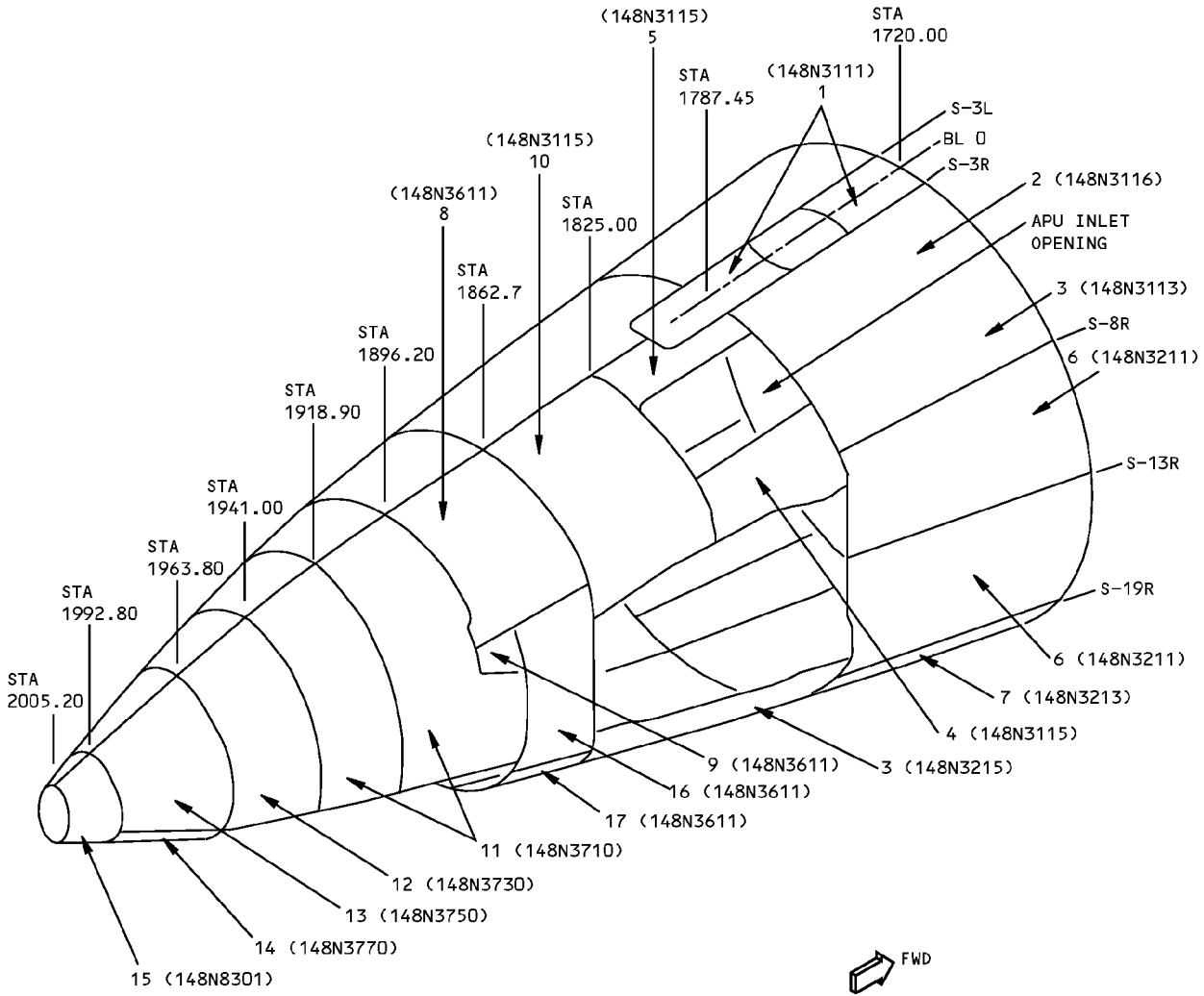
ITEM	DESCRIPTION	GAGE	MATERIAL	EFFECTIVITY		
1	SKIN	0.180	7075-T651 (CHEM-MILLED TO 0.090 MIN)	<table border="1"> <tr> <td>A</td> </tr> <tr> <td>B</td> </tr> </table>	A	B
A						
B						
2	SKIN	0.100	CLAD 7075-T6 (CHEM-MILLED TO 0.040 MIN)			
3	SKIN	0.095	CLAD 7075-T6 (CHEM-MILLED TO 0.040 MIN) (CHEM-MILLED TO 0.050 MIN)			
4	SKIN	0.125	CLAD 7075-T62 (CHEM-MILLED TO 0.040 MIN)			
5	SKIN	0.100	CLAD 7075-T62 (CHEM-MILLED TO 0.058 MIN)			
6	SKIN	0.120	CLAD 7075-T6 (CHEM-MILLED TO 0.040 MIN)			
7	SKIN	0.093	CLAD 7075-T6 (CHEM-MILLED TO 0.050 MIN)			
8	SKIN	0.095	CLAD 7075-T62 (CHEM-MILLED TO 0.040 MIN)			
9	SKIN	0.112	CLAD 7075-T62 (CHEM-MILLED TO 0.080 MIN)			
10	SKIN ASSEMBLY					
	INNER SKIN	0.012	2024-T42			
	INNER SKIN	0.012	CLAD 2024-T42			
	CORE	0.500	METALLIC HONEYCOMB PER BMS 4-4 3-10N			
	OUTER SKIN	0.080	CLAD 2024-T42 (CHEM-MILLED TO 0.020 MIN)			
11	SKIN ASSEMBLY					
	INNER SKIN	0.012	2024-T42			
	CORE	0.500	METALLIC HONEYCOMB PER BMS 4-4 3-10N			
	OUTER SKIN	0.070	CLAD 2024-T42 (CHEM-MILLED TO 0.020 MIN)			
12	SKIN ASSEMBLY					
	INNER SKIN	0.012	2024-T42			
	CORE	0.500	METALLIC HONEYCOMB PER BMS 4-4 3-10N			
	OUTER SKIN	0.063	CLAD 2024-T42 (CHEM-MILLED TO 0.020 MIN)			
13	SKIN	0.025	Ti-6AL-4V SHEET			
14	SKIN	0.112	CLAD 7075-T62 (CHEM-MILLED TO 0.080 MIN)			

LIST OF MATERIALS FOR DETAIL I

**Section 48 Skin Identification
Figure 1 (Sheet 3 of 7)**

**757-200
STRUCTURAL REPAIR MANUAL**

REF DWG
148N0006



**RIGHT SIDE
DETAIL II**

LIST OF
MATERIAL

**Section 48 Skin Identification
Figure 1 (Sheet 4 of 7)**

IDENTIFICATION 1
Page 4
Jan 20/2005

53-80-01

D634N201



**757-200
STRUCTURAL REPAIR MANUAL**

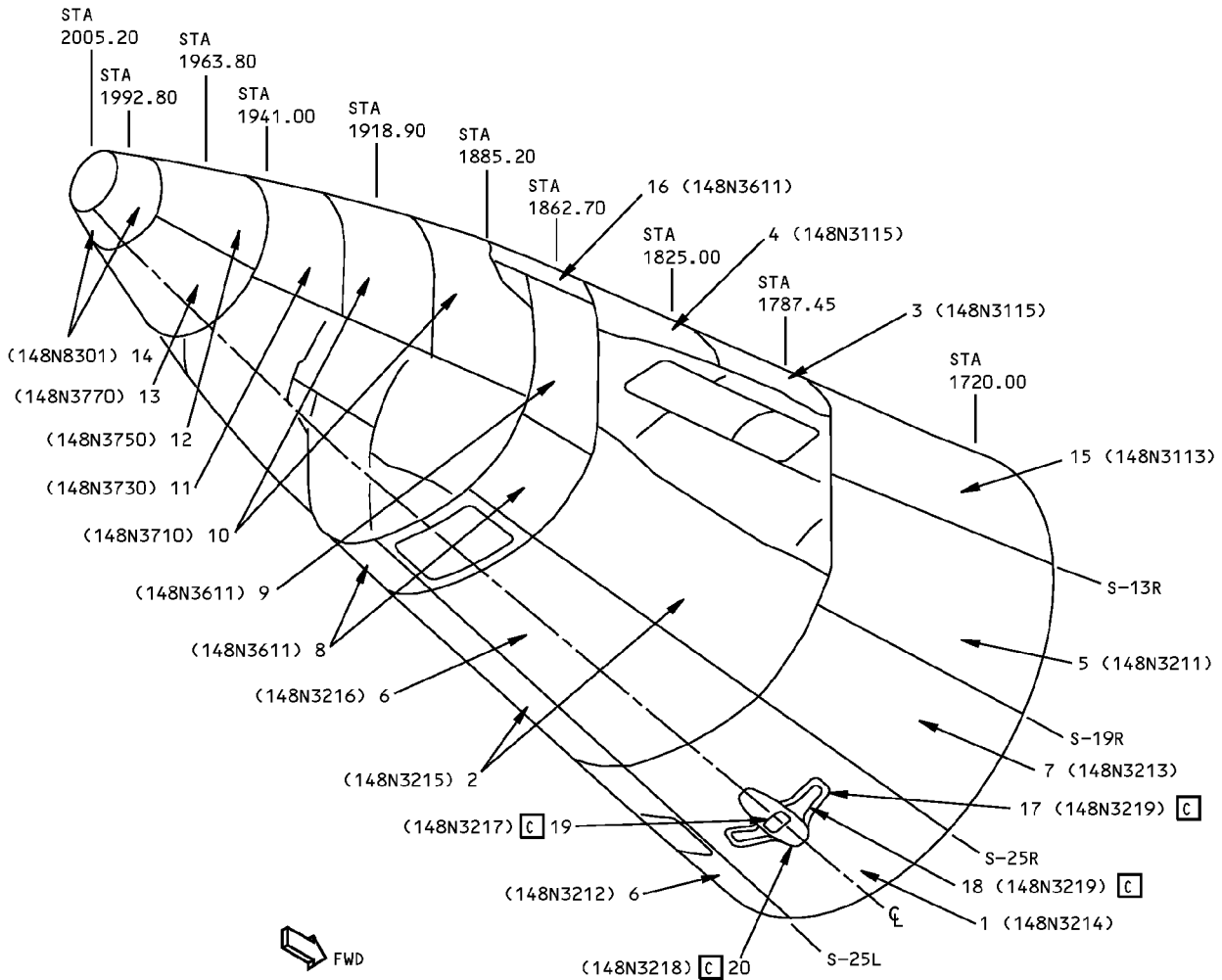
ITEM	DESCRIPTION	GAGE	MATERIAL	EFFECTIVITY		
1	SKIN	0.180	7075-T651 (CHEM-MILLED TO 0.090 MIN)	<table border="1"> <tr> <td>A</td> </tr> <tr> <td>B</td> </tr> </table>	A	B
A						
B						
2	SKIN	0.100	CLAD 7075-T6 (CHEM-MILLED TO 0.040 MIN)			
3	SKIN	0.095	CLAD 7075-T6 (CHEM-MILLED TO 0.040 MIN) (CHEM-MILLED TO 0.050 MIN)			
4	SKIN	0.125	CLAD 7075-T62 (CHEM-MILLED TO 0.080 MIN)			
5	SKIN	0.100	CLAD 7075-T62 (CHEM-MILLED TO 0.058 MIN)			
6	SKIN	0.100	CLAD 7075-T6 (CHEM-MILLED TO 0.050 MIN)			
7	SKIN	0.071	CLAD 7075-T6 (CHEM-MILLED TO 0.040 MIN)			
8	SKIN	0.095	CLAD 7075-T62 (CHEM-MILLED TO 0.040 MIN)			
9	SKIN	0.112	CLAD 7075-T62 (CHEM-MILLED TO 0.080 MIN)			
10	SKIN	0.120	CLAD 7075-T6 (CHEM-MILLED TO 0.040 MIN)			
11	SKIN ASSEMBLY					
	INNER SKIN	0.012	2024-T42			
	INNER SKIN	0.012	CLAD 2024-T42			
	CORE	0.500	METALLIC HONEYCOMB PER BMS 4-4 3-10N			
	OUTER SKIN	0.080	CLAD 2024-T42 (CHEM-MILLED TO 0.020 MIN)			
12	SKIN ASSEMBLY					
	INNER SKIN	0.012	2024-T42			
	CORE	0.500	METALLIC HONEYCOMB PER BMS 4-4 3-10N			
	OUTER SKIN	0.070	CLAD 2024-T42 (CHEM-MILLED TO 0.020 MIN)			
13	SKIN ASSEMBLY					
	INNER SKIN	0.012	2024-T42			
	CORE	0.500	METALLIC HONEYCOMB PER BMS 4-4 3-10N			
	OUTER SKIN	0.063	CLAD 2024-T42 (CHEM-MILLED TO 0.020 MIN)			
14	SKIN ASSEMBLY					
	INNER SKIN	0.012	2024-T3			
	CORE	0.500	METALLIC HONEYCOMB PER BMS 4-4 3-20N			
	OUTER SKIN	0.080	CLAD 2024-T42 (CHEM-MILLED TO 0.020 MIN)			
15	SKIN	0.025	Ti-6AL-4V PER MIL-T-9046 TYPE III, COMP C			
16	SKIN	0.112	CLAD 7075-T62 (CHEM-MILLED TO 0.080 MIN)			
17	SKIN	0.095	CLAD 7075-T62 (CHEM-MILLED TO 0.050 MIN)			

LIST OF MATERIALS FOR DETAIL II

**Section 48 Skin Identification
Figure 1 (Sheet 5 of 7)**

**757-200
STRUCTURAL REPAIR MANUAL**

REF DWG
148N0006



**BOTTOM VIEW
DETAIL III**

**Section 48 Skin Identification
Figure 1 (Sheet 6 of 7)**

LIST OF
MATL

IDENTIFICATION 1
Page 6
Jan 20/2005

53-80-01

D634N201



**757-200
STRUCTURAL REPAIR MANUAL**

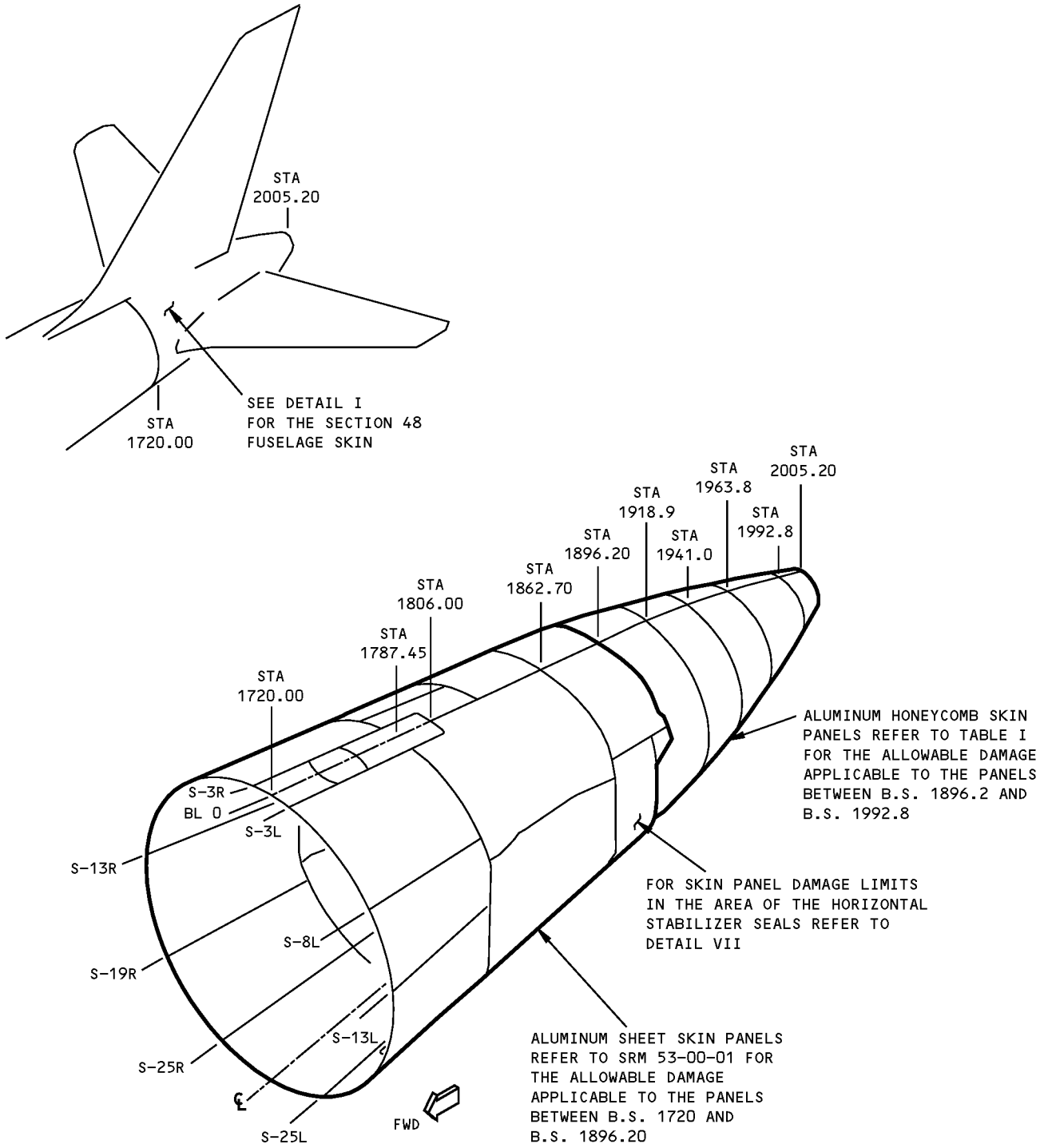
ITEM	DESCRIPTION	GAGE	MATERIAL	EFFECTIVITY
1	SKIN	0.100	CLAD 7075-T6 (CHEM-MILLED TO 0.040 MIN)	
2	SKIN	0.125	CLAD 7075-T6 (CHEM-MILLED TO 0.040 MIN)	
3	SKIN	0.125	CLAD 7075-T62 (CHEM-MILLED TO 0.080 MIN)	
4	SKIN	0.120	CLAD 7075-T6 (CHEM-MILLED TO 0.040 MIN)	
5	SKIN	0.100	CLAD 7075-T6 (CHEM-MILLED TO 0.050 MIN)	
6	SKIN	0.072	CLAD 7075-T6 (CHEM-MILLED TO 0.040 MIN)	
7	SKIN	0.071	CLAD 7075-T6 (CHEM-MILLED TO 0.040 MIN)	
8	SKIN	0.095	CLAD 7075-T62 (CHEM-MILLED TO 0.050 MIN)	
9	SKIN	0.112	CLAD 7075-T62 (CHEM-MILLED TO 0.080 MIN)	
10	SKIN ASSEMBLY			
	INNER SKIN	0.012	2024-T42	
	INNER SKIN	0.012	CLAD 2024-T42	
	CORE	0.500	METALLIC HONEYCOMB PER BMS 4-4 3-10N	
	OUTER SKIN	0.080	CLAD 2024-T42 (CHEM-MILLED TO 0.020 MIN)	
11	SKIN ASSEMBLY			
	INNER SKIN	0.012	2024-T42	
	CORE	0.500	METALLIC HONEYCOMB PER BMS 4-4 3-10N	
	OUTER SKIN	0.070	CLAD 2024-T42 (CHEM-MILLED TO 0.020 MIN)	
12	SKIN ASSEMBLY			
	INNER SKIN	0.012	2024-T42	
	CORE	0.500	METALLIC HONEYCOMB PER BMS 4-4 3-10N	
	OUTER SKIN	0.063	CLAD 2024-T42 (CHEM-MILLED TO 0.020 MIN)	
13	SKIN ASSEMBLY			
	INNER SKIN	0.012	2024-T3	
	CORE	0.500	METALLIC HONEYCOMB PER BMS 4-4 3-20N	
	OUTER SKIN	0.080	CLAD 2024-T42 (CHEM-MILLED TO 0.020 MIN)	
14	SKIN	0.025	TI-6AL-4V SHEET	
15	SKIN	0.095	CLAD 7075-T62 (CHEM-MILLED TO 0.040 MIN)	A
		0.095	CLAD 7075-T62 (CHEM-MILLED TO 0.050 MIN)	B
16	SKIN	0.095	CLAD 7075-T62 (CHEM-MILLED TO 0.040 MIN)	
17	STRAP	0.050	7075-T6	A
18	STRAP	0.050	7075-T6	A
19	SHOE		NICKEL ALLOY 718 FORGING PER AMS 5662	A
20	FAIRING		LYTEX 9063	A

LIST OF MATERIALS FOR DETAIL III

**Section 48 Skin Identification
Figure 1 (Sheet 7 of 7)**

**757-200
STRUCTURAL REPAIR MANUAL**

ALLOWABLE DAMAGE GENERAL - SECTION 48 - SKINS



LEFT SIDE IS SHOWN
DETAIL I

**Section 48 Skin Allowable Damage
Figure 101 (Sheet 1 of 6)**

STRUCTURAL REPAIR MANUAL

DESCRIPTION	CRACKS	NICKS, GOUGES AND CORROSION	DENTS	HOLES AND PUNCTURES	DELAMINATION
ALUMINUM HONEYCOMB SKIN PANELS	A	B	C	D	E

NOTES

- REFER TO AMM 51-24-13 FOR APPLICATION OF ABRASION RESISTANT TEFLON FINISH.
- REFER TO AMM 53-86-01 FOR INSTALLATION OF THE STABILIZER FAIRING SEAL.
- REFER TO THE NDT MANUAL D634N301, PART 6, SECTIONS 51-00-01, OR 51-00-19 FOR HIGH FREQUENCY EDDY CURRENT INSPECTION PROCEDURES.
- REFER TO SRM 51-10-01 FOR AERODYNAMIC SMOOTHNESS REQUIREMENTS. WHERE THE DAMAGE EXCEEDS THE LIMITS SHOWN IN SRM 51-10-01, CONSIDERATION SHOULD BE GIVEN TO THE LOSS OF PERFORMANCE INVOLVED.
- REFER TO SRM 51-10-02 FOR INSPECTION AND REMOVAL OF DAMAGE.
- REFER TO SRM 51-20-01 FOR PROTECTIVE TREATMENT OF REWORKED AREAS.
- REFER TO SRM 51-40 FOR FASTENER CODES, INSTALLATION AND REMOVAL, HOLE SIZES, AND EDGE MARGINS.

A CLEAN UP EDGE CRACKS AS SHOWN IN DETAILS II AND VI. 0.50 INCH (12.7 mm) MAX LENGTH CRACK PERMITTED IN HONEYCOMB AREA. STOP DRILL ENDS OF CRACK WITH 0.25 INCH (6 mm) DIAMETER HOLE. **F**

B REMOVE DAMAGE AS SHOWN IN DETAILS III AND V.

- C**
- DENTS THAT ARE LESS THAN OR EQUAL TO 0.05 INCH (1.27 mm) IN DEPTH (Y) ARE PERMITTED AS GIVEN IN DETAIL IV.
 - DENTS THAT ARE MORE THAN 0.05 INCH (1.27 mm) BUT LESS THAN OR EQUAL TO 0.100 INCH (2.5 mm) IN DEPTH (Y) ARE PERMITTED AS GIVEN IN DETAIL IV IF:
 - IT IS FILLED WITH POTTING COMPOUND AS GIVEN IN SRM 51-70-01
 - IT IS SEALED WITH ALUMINUM FOIL TAPE (SPEED TAPE) 3M-Y436 OR ITS EQUIVALENT. KEEP A RECORD OF THE LOCATION WHERE THE SPEED TAPE IS APPLIED
 - AT EACH "2A" CHECK, AN INSPECTION IS MADE OF THE LOCATION WHERE THE SPEED TAPE IS APPLIED. REPLACE THE TAPE IF DETERIORATION IS FOUND. IT IS POSSIBLE THAT THERE WILL BE DETERIORATION OF THE SPEED TAPE IN SOME AREAS OF THE SKIN BEFORE THE NEXT NECESSARY INSPECTION. IF DETERIORATION IS FOUND, INSPECT THE TAPE MORE FREQUENTLY.
 - A PERMANENT REPAIR IS MADE NO LATER THAN THE NEXT "C" CHECK. REFER TO SRM 51-70-10.

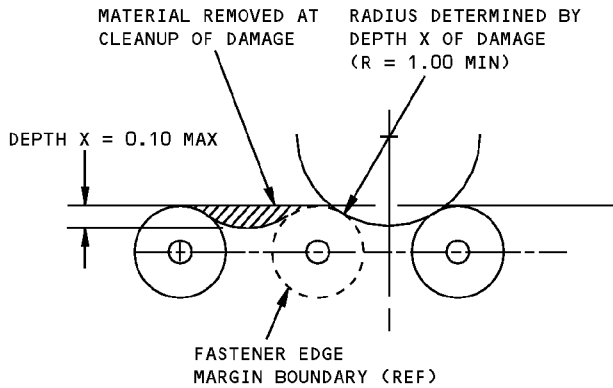
TABLE I

- DENTS THAT ARE MORE THAN 0.100 INCH (2.5 mm) BUT LESS THAN OR EQUAL TO 0.150 INCH (3.8 mm) IN DEPTH (Y) ARE PERMITTED AS GIVEN IN DETAIL IV IF:
 - IT IS FILLED WITH POTTING COMPOUND AS GIVEN IN SRM 51-70-01
 - IT IS SEALED WITH ALUMINUM FOIL TAPE (SPEED TAPE) 3M-Y436 OR ITS EQUIVALENT. KEEP A RECORD OF THE LOCATION WHERE THE SPEED TAPE IS APPLIED
 - AT EACH "A" CHECK, AN INSPECTION IS MADE OF THE LOCATION WHERE THE SPEED TAPE IS APPLIED. REPLACE THE TAPE IF DETERIORATION IS FOUND. IT IS POSSIBLE THAT THERE WILL BE DETERIORATION OF THE SPEED TAPE IN SOME AREAS OF THE SKIN BEFORE THE NEXT NECESSARY INSPECTION. IF DETERIORATION IS FOUND, INSPECT THE TAPE MORE FREQUENTLY.
 - A PERMANENT REPAIR IS MADE NO LATER THAN 1000 FLIGHT HOURS. REFER TO SRM 51-70-10.
- D** CLEAN UP DAMAGE TO 0.25 INCH (6 mm) MAX DIAMETER HOLE AND NOT CLOSER THAN 1.0 INCH (25 mm) TO FASTENER HOLE, EDGE OF PART OR OTHER DAMAGE. ONE HOLE FOR EACH 15.0 SQUARE INCHES (9677 SQUARE mm) OF PANEL PERMITTED. **F**
- E** 0.50 INCH (12.7 mm) MAX DIMENSION (D) IN HONEYCOMB AREA IS PERMITTED FOR EACH SQUARE FOOT OF AREA AND A MINIMUM OF 4D (EDGE TO EDGE) FROM OTHER DAMAGE, FASTENER HOLE OR PANEL EDGE. A MAXIMUM OF 0.10 INCH (2.5 mm) DELAMINATION FROM EDGE IS PERMITTED. PROTECT EDGE DAMAGE AS GIVEN IN **F**. REPAIR DELAMINATION IN HONEYCOMB AREA AS GIVEN IN SRM 51-70 NO LATER THAN THE NEXT "C" CHECK.
- F** REMOVE MOISTURE FROM DAMAGE AREA. USE OF VACUUM AND HEAT (MAX OF 165°F (74°C)) TO REMOVE MOISTURE FROM HONEYCOMB CELLS IS RECOMMENDED. PROTECT DAMAGE FROM ENTRANCE OF WATER, SUNLIGHT OR OTHER FOREIGN MATTER BY SEALING WITH ALUMINUM FOIL TAPE (SPEED TAPE). RECORD THE LOCATION AND INSPECT EVERY AIRPLANE "A" CHECK. REPLACE THE ALUMINUM FOIL TAPE IF ANY PEELING OR DETERIORATION IS FOUND. REPAIR NO LATER THAN NEXT AIRPLANE "C" CHECK. **G**
- G** THESE ALLOWABLE DAMAGE LIMITS HAVE FAA APPROVAL CONTINGENT UPON ACCOMPLISHMENT OF THE INSPECTIONS CONTAINED HEREIN.
- H** THE MAXIMUM GOUGE LENGTH PERMITTED IS 7 INCHES (178 mm). GOUGE WIDTH MUST NOT BE MORE THAN THE PITCH OF THE FASTENERS. REFER TO DETAIL VII FOR THE GOUGE DEPTH PERMITTED.

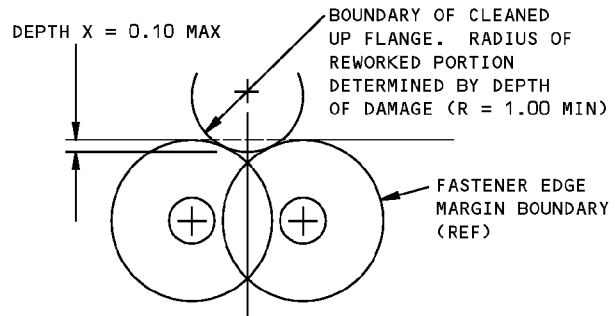
Section 48 Skin Allowable Damage
Figure 101 (Sheet 2 of 6)

STRUCTURAL REPAIR MANUAL

- I** REPLACE ALL DAMAGED FASTENERS. MAKE SURE THAT COUNTERSINKS FOR THE REPLACEMENT FASTENERS DO NOT CAUSE A KNIFE EDGE CONDITION. REFER TO SECTION C-C.
- J** DO A HFEC INSPECTION TO ENSURE THERE ARE NO CRACKS.
- K** THE MAXIMUM GOUGE LENGTH PERMITTED IS 20 INCHES.
- L** 25% OF THE LENGTH OF THE GOUGE IS PERMITTED TO BE A MAXIMUM OF 0.025 INCH IN DEPTH. THE REMAINING LENGTH OF THE GOUGE IS PERMITTED TO BE ONLY 0.020 INCH IN DEPTH.
- M** PUT TEFLON PAINT IN THE DAMAGED AREA TO MINIMIZE WEAR.
- N** ADJUST THE STABILIZER FAIRING SEALS IF NECESSARY.

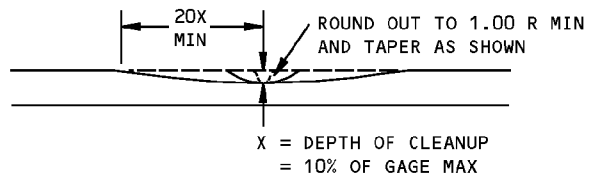
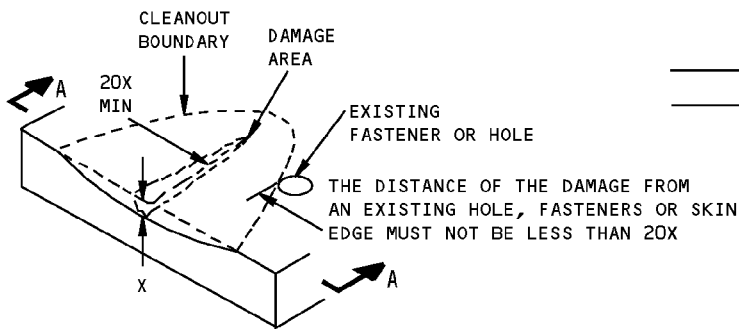


DAMAGE CLEANUP OF EDGES WHERE FASTENER EDGE MARGINS DO NOT OVERLAP



DAMAGE CLEANUP OF EDGES WHERE FASTENER EDGE MARGINS OVERLAP

DETAIL II

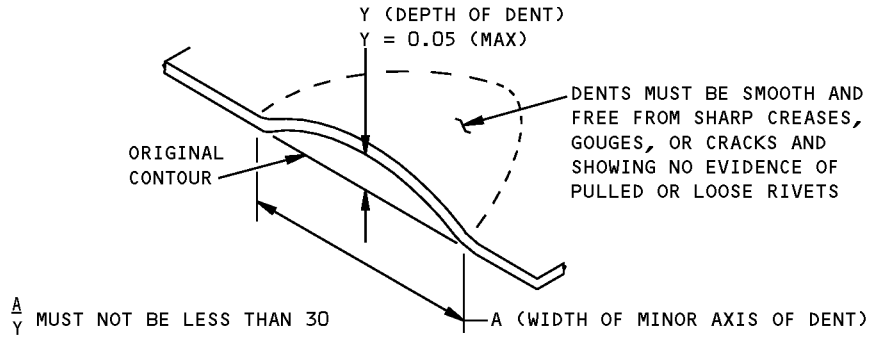


SECTION A-A

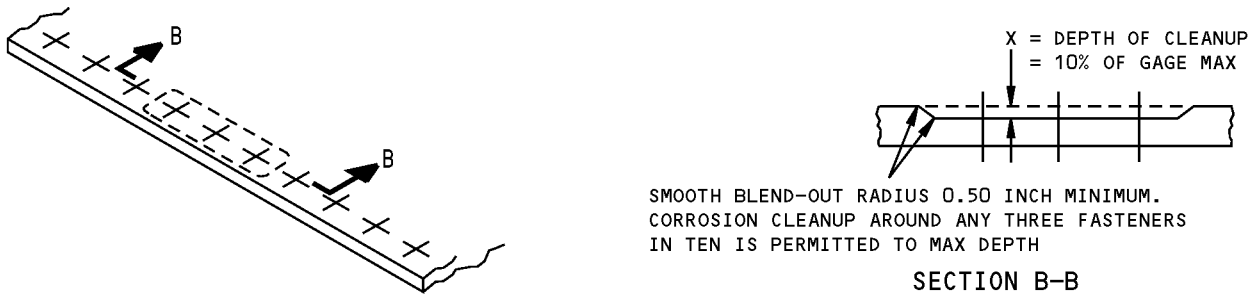
REMOVAL OF NICK, GOUGE AND SCRATCH DAMAGE ON A SURFACE
DETAIL III

**Section 48 Skin Allowable Damage
Figure 101 (Sheet 3 of 6)**

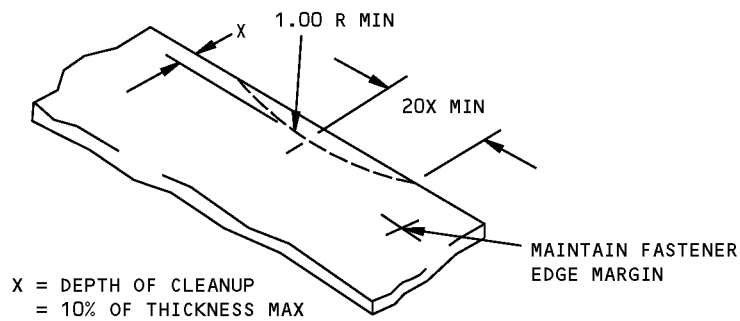
**757-200
STRUCTURAL REPAIR MANUAL**



**ALLOWABLE DAMAGE FOR DENT
DETAIL IV**



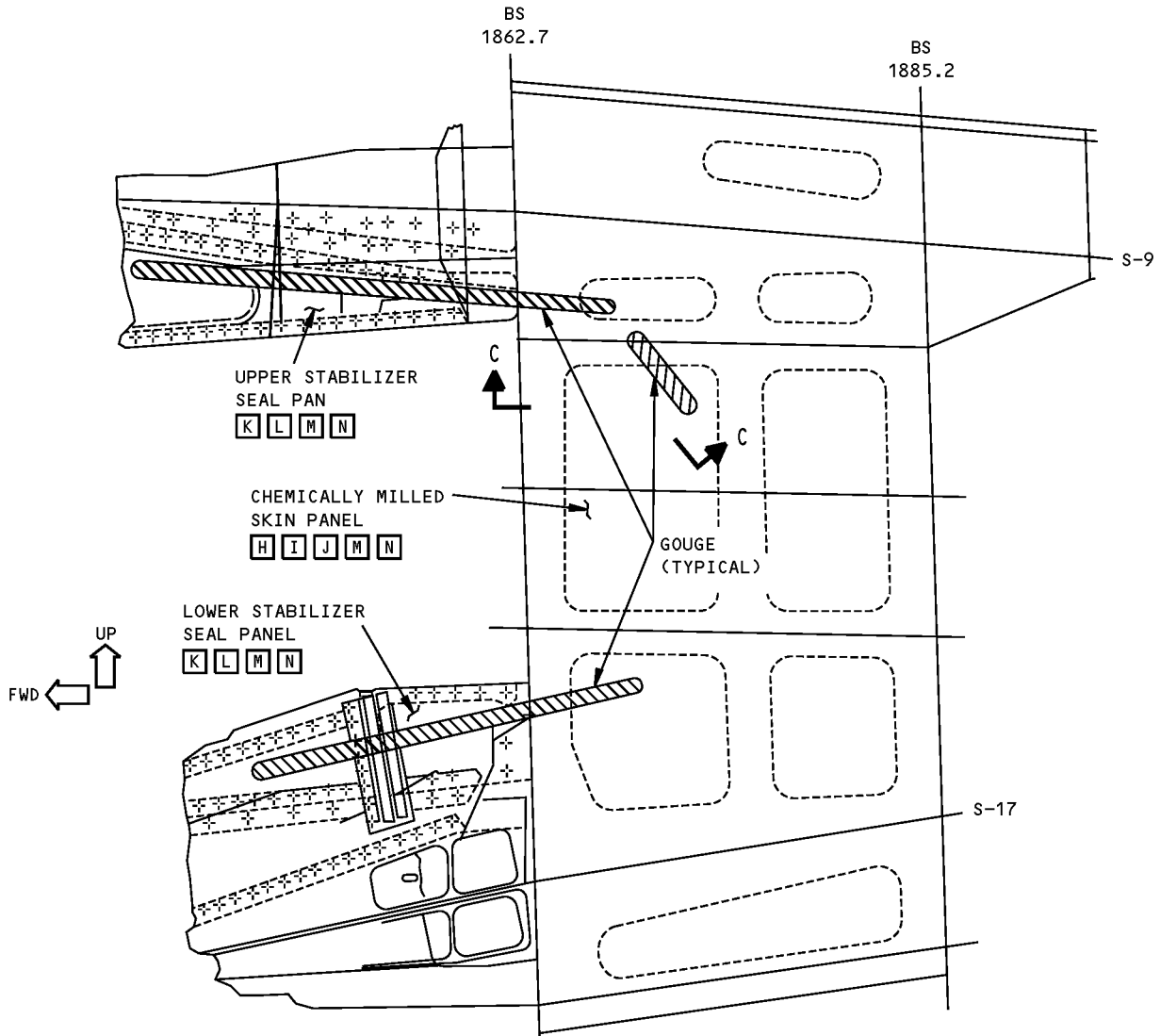
**CORROSION CLEANUP
DETAIL V**



**REMOVAL OF NICK OR CRACK DAMAGE ON AN EDGE
DETAIL VI**

**Section 48 Skin Allowable Damage
Figure 101 (Sheet 4 of 6)**

**757-200
STRUCTURAL REPAIR MANUAL**

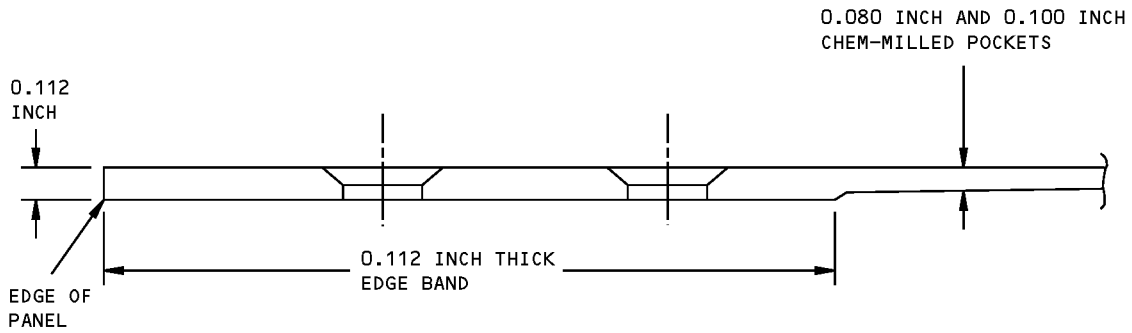


TYPICAL SKIN WEAR PATTERNS CAUSED BY THE STABILIZER BLADE SEAL
DETAIL VII

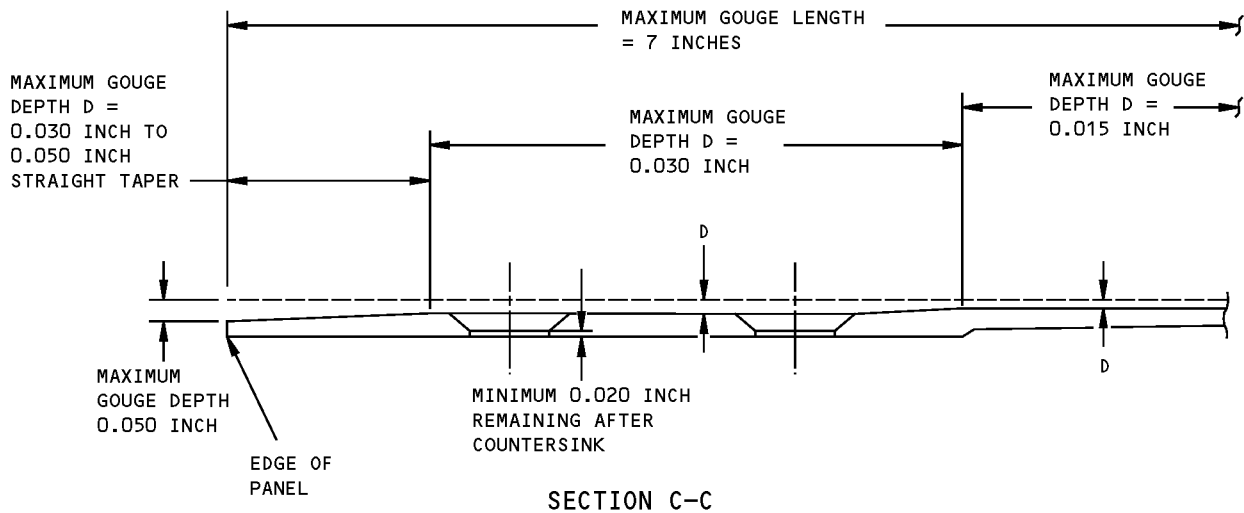
**Section 48 Skin Allowable Damage
Figure 101 (Sheet 5 of 6)**

D634N201

**757-200
STRUCTURAL REPAIR MANUAL**



INITIAL PANEL THICKNESS

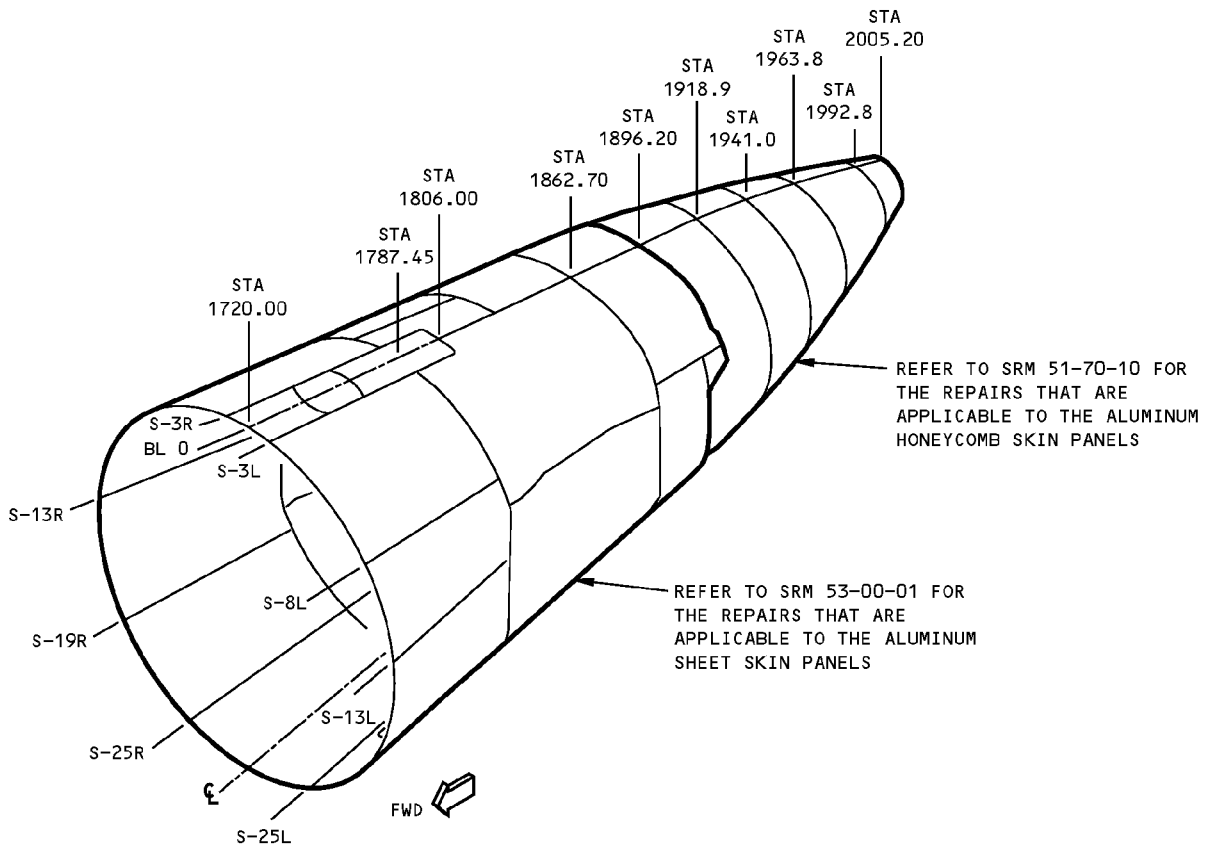
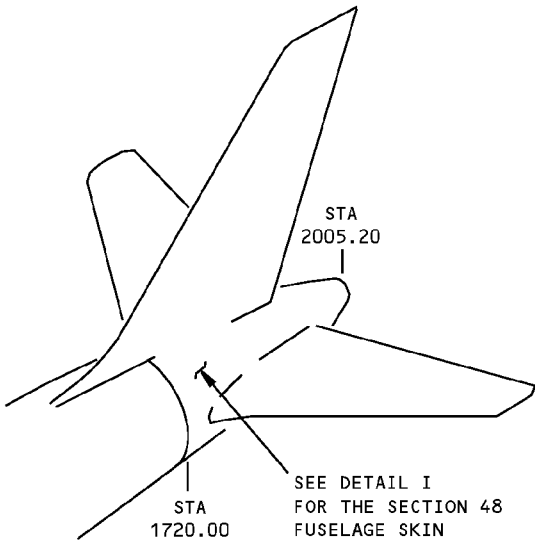


SECTION C-C

**Section 48 Skin Allowable Damage
Figure 101 (Sheet 6 of 6)**

**757-200
STRUCTURAL REPAIR MANUAL**

REPAIR GENERAL - SECTION 48 - SKINS



LEFT SIDE IS SHOWN
DETAIL I

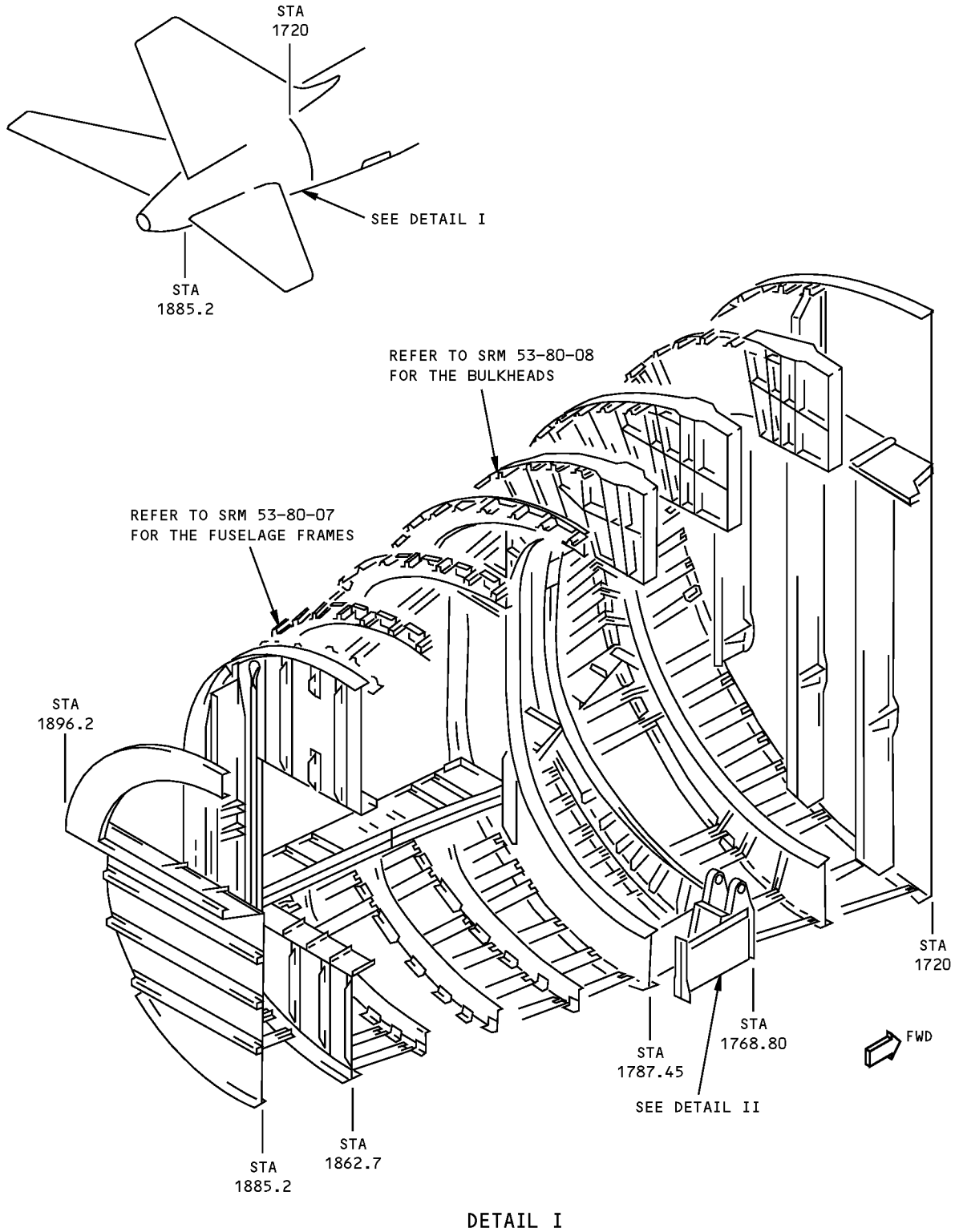
**Section 48 Skin Repairs
Figure 201**

D634N201

53-80-01

**757-200
STRUCTURAL REPAIR MANUAL**

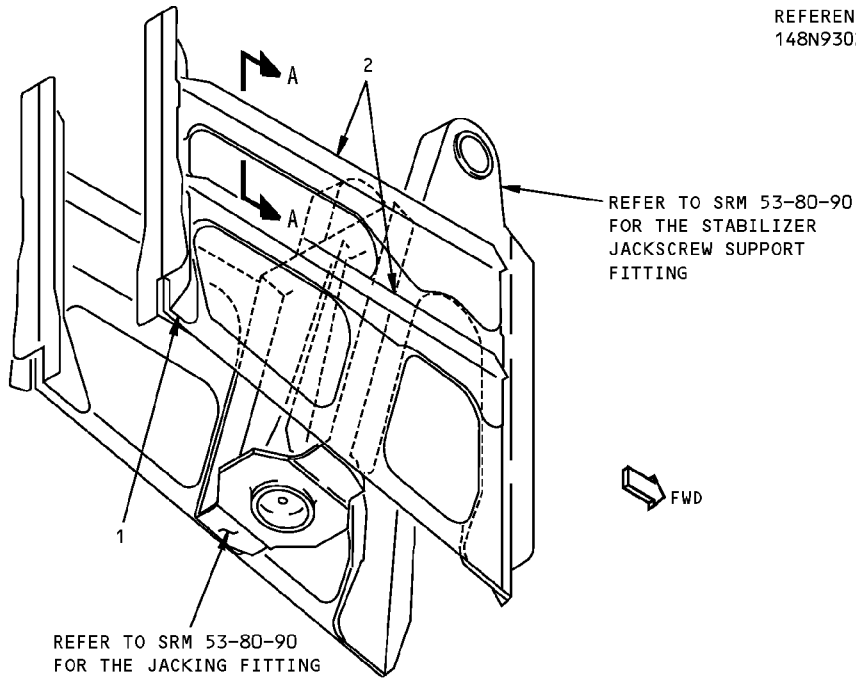
IDENTIFICATION 1 - SECTION 48 - STABILIZER JACKSCREW SUPPORT FITTING STRUCTURE



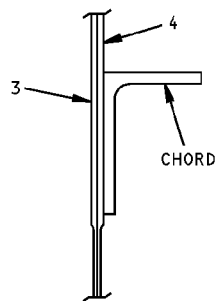
**Section 48 Stabilizer Jackscrew Support Fitting Structure Identification
Figure 1 (Sheet 1 of 2)**

**757-200
STRUCTURAL REPAIR MANUAL**

REFERENCE DRAWING
148N9302



**STABILIZER JACKSCREW SUPPORT FITTING STRUCTURE
DETAIL II**



SECTION A-A

ITEM	DESCRIPTION	GAGE	MATERIAL	EFFECTIVITY
1	STRINGER		BAC1503-100388 7075-T6511	
2	CHORD		BAC1503-100184 7075-T6511	
3	WEB LH	0.040	7075-T6 (CHEM MILLED TO 0.029 MINIMUM)	
4	WEB RH	0.040	7075-T6 (CHEM MILLED TO 0.029 MINIMUM)	

LIST OF MATERIALS FOR DETAIL II

**Section 48 Stabilizer Jackscrew Support Fitting Structure Identification
Figure 1 (Sheet 2 of 2)**

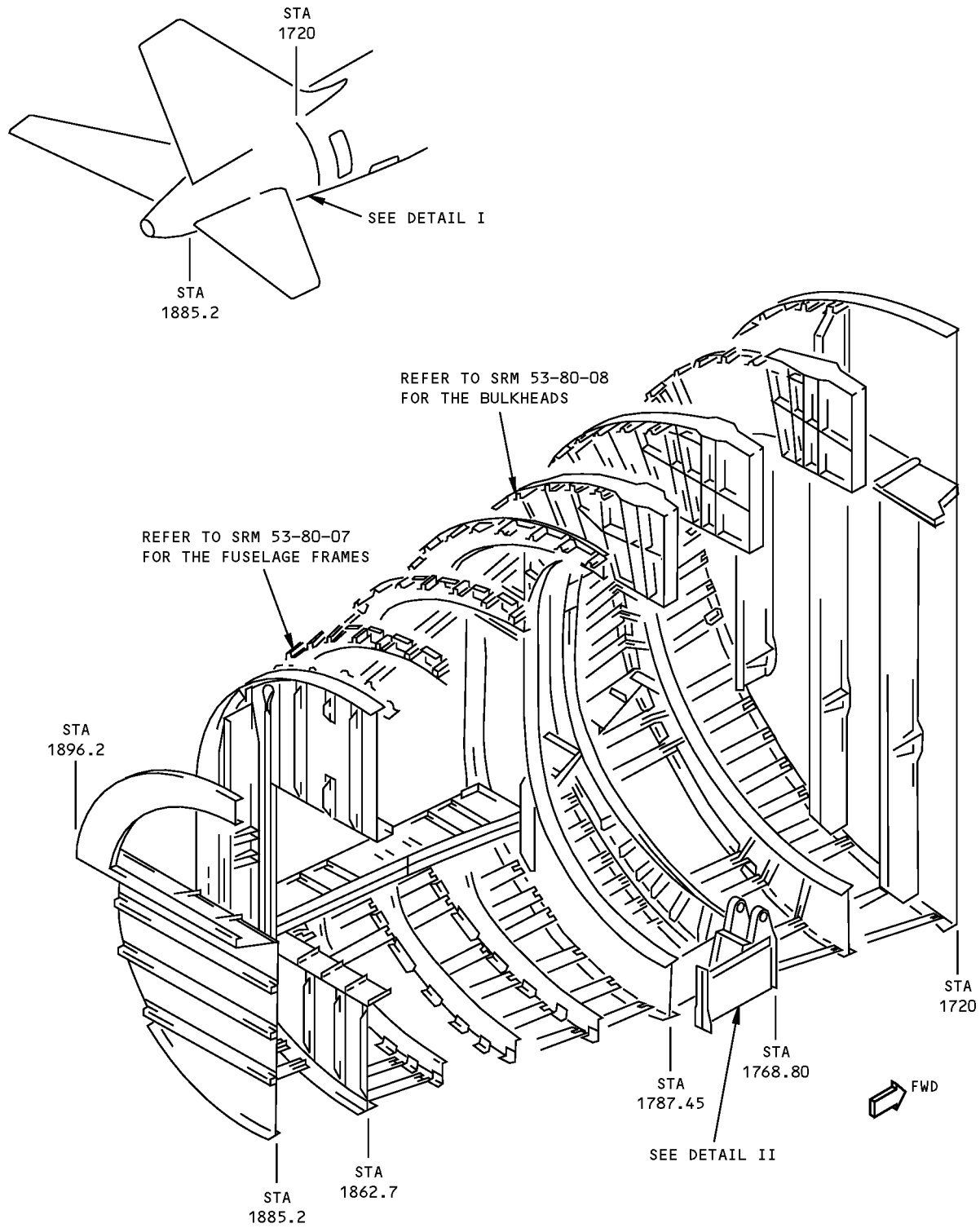
IDENTIFICATION 1
Page 2
Jan 20/2005

53-80-02

D634N201

**757-200
STRUCTURAL REPAIR MANUAL**

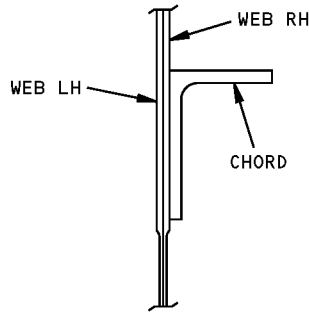
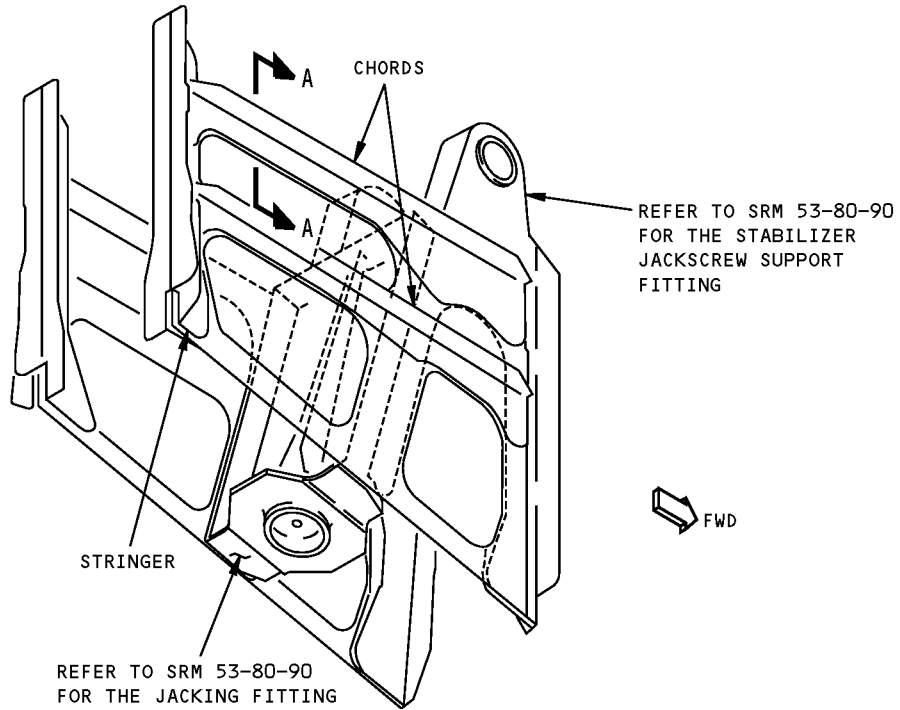
ALLOWABLE DAMAGE GENERAL - SECTION 48 - STABILIZER JACKSCREW SUPPORT FITTING STRUCTURE



DETAIL I

**Section 48 Stabilizer Jackscrew Support Fitting Structure Allowable Damage
Figure 101 (Sheet 1 of 4)**

**757-200
STRUCTURAL REPAIR MANUAL**



SECTION A-A

DESCRIPTION	CRACKS	NICKS, GOUGES AND CORROSION	DENTS	HOLES AND PUNCTURES
STRINGERS	A	D	NOT PERMITTED	NOT PERMITTED
WEBS	B	D	SEE DETAIL IV	C
CHORDS	A	D	NOT PERMITTED	NOT PERMITTED

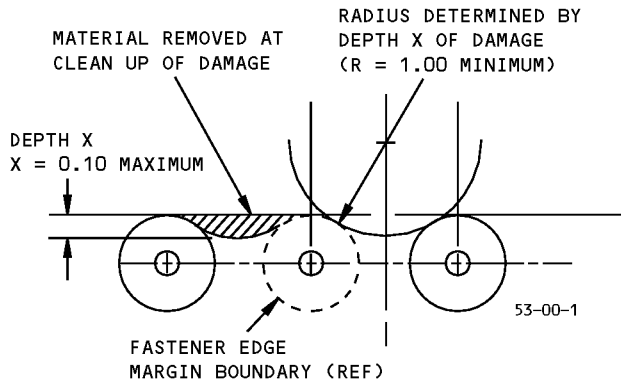
STABILIZER JACKSCREW SUPPORT FITTING STRUCTURE
DETAIL II

**Section 48 Stabilizer Jackscrew Support Fitting Structure Allowable Damage
Figure 101 (Sheet 2 of 4)**

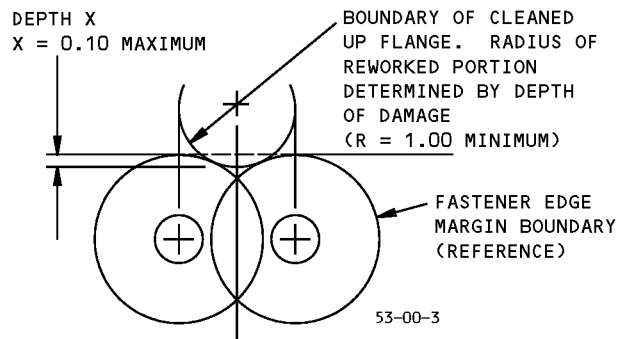
**757-200
STRUCTURAL REPAIR MANUAL**

NOTES

- REFINISH REWORKED AREAS AS GIVEN IN AMM 51-20
- A** CRACKS NOT ALLOWED EXCEPT FOR EDGE CRACKS WHICH MUST BE REMOVED AS GIVEN IN DETAILS III AND VII
- B** CRACKS NOT ALLOWED EXCEPT FOR EDGE CRACKS WHICH MUST BE REMOVED AS GIVEN IN DETAILS III AND VI
- C** CLEAN OUT DAMAGE UP TO 0.25 MAXIMUM DIA AND NOT CLOSER THAN 1.0 INCH TO FASTENER HOLE. FILL HOLE WITH A 2117-T3 OR T4 ALUMINUM RIVET INSTALLED WET WITH BMS 5-95 SEALANT. ALL OTHER HOLES TO BE REPAIRED
- D** REMOVE THE DAMAGE AS GIVEN IN DETAIL IV

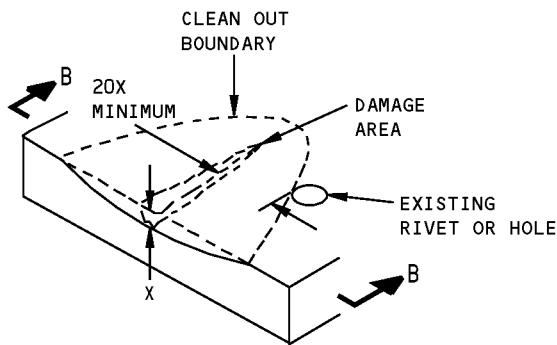


DAMAGE CLEAN UP OF EDGES WHERE FASTENER EDGE MARGINS DO NOT OVERLAP

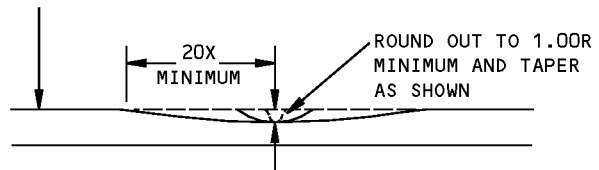


DAMAGE CLEAN UP OF EDGES WHERE FASTENER EDGE MARGINS OVERLAP

DETAIL III



THE DISTANCE OF THE DAMAGE FROM AN EXISTING HOLE, FASTENERS OR SKIN EDGE MUST NOT BE LESS THAN 20X



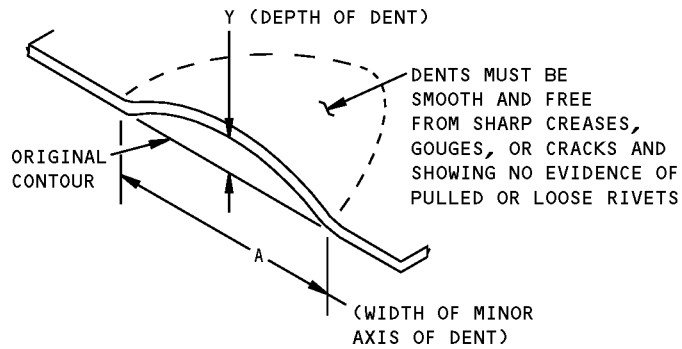
X = DEPTH OF DAMAGE = 0.10 MAXIMUM
MAXIMUM CLEANUP 15%

B-B

**REMOVAL OF NICK, GOUGE AND SCRATCH DAMAGE ON A SURFACE
DETAIL IV**

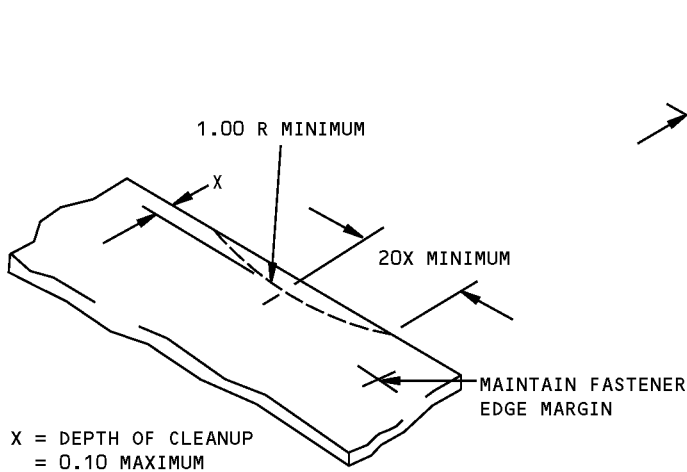
**Section 48 Stabilizer Jackscrew Support Fitting Structure Allowable Damage
Figure 101 (Sheet 3 of 4)**

**757-200
STRUCTURAL REPAIR MANUAL**

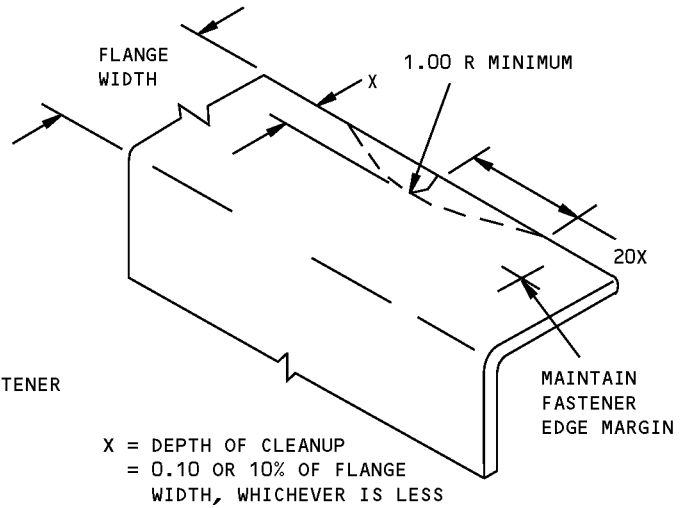


$\frac{A}{Y}$ MUST NOT BE LESS THAN 30
 Y MAXIMUM = 0.05 OR WEB THICKNESS,
 WHICHEVER IS LESS

**ALLOWABLE DAMAGE FOR DENT
DETAIL V**



**REMOVAL OF NICK OR CRACK
DAMAGE ON AN EDGE
DETAIL VI**

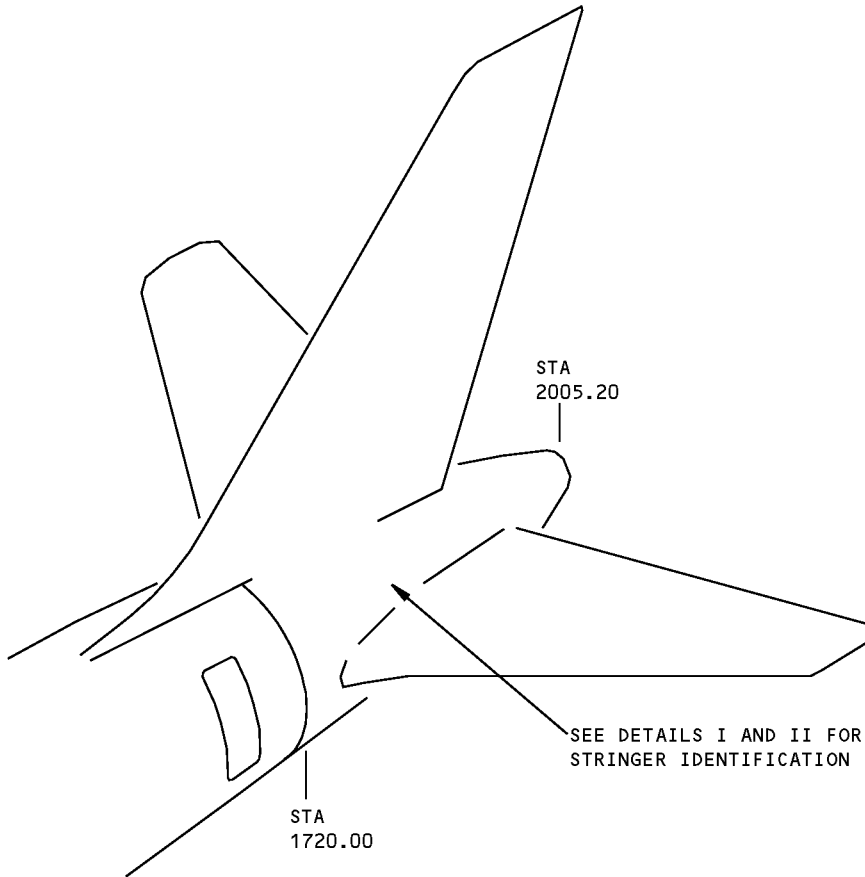


**REMOVAL OF NICK OR CRACK
DAMAGE ON AN EDGE
DETAIL VII**

**Section 48 Stabilizer Jackscrew Support Fitting Structure Allowable Damage
Figure 101 (Sheet 4 of 4)**

757-200
STRUCTURAL REPAIR MANUAL

IDENTIFICATION 1 - SECTION 48 - STRINGERS



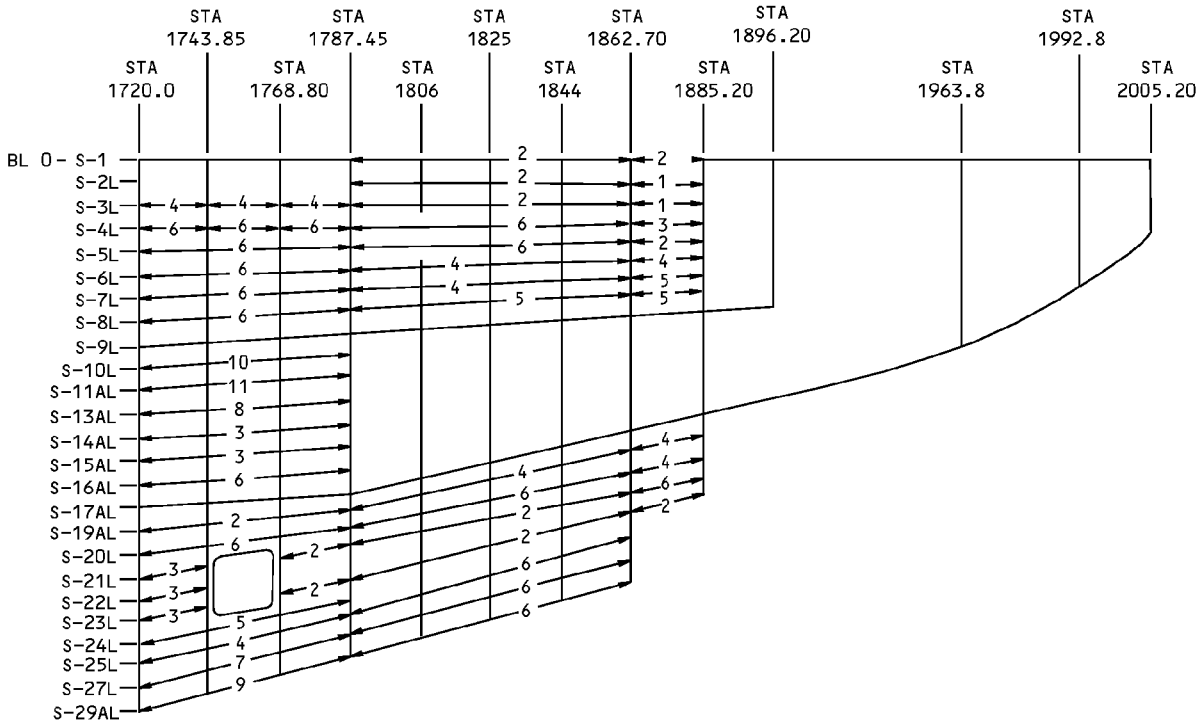
NOTES

- A** GAGE VARIES ALONG THE LENGTH OF THE STRINGER
- B** FOR CUM LINE NUMBERS:
1 THRU 37
- C** FOR CUM LINE NUMBERS:
37 AND ON

Section 48 Stringer Identification
Figure 1 (Sheet 1 of 5)

**757-200
STRUCTURAL REPAIR MANUAL**

REF DWG
148N3123
148N3124
148N3134
148N3204
148N3221



← FWD

LEFT SIDE
DETAIL I

→ LIST OF
MATERIAL

**Section 48 Stringer Identification
Figure 1 (Sheet 2 of 5)**

IDENTIFICATION 1
Page 2
Jan 20/2005

53-80-03

D634N201



**757-200
STRUCTURAL REPAIR MANUAL**

ITEM	DESCRIPTION	GAGE	MATERIAL	STRINGER TYPE	EFFECTIVITY
1	STRINGER		BAC1498-141 7075-T6	U	
2	STRINGER		BAC1498-143 7075-T6	U	
3	STRINGER		BAC1498-142 7075-T6	U	
4	STRINGER		BAC1498-145 7075-T6	U	
5	STRINGER		BAC1498-146 7075-T6	U	
6	STRINGER		BAC1498-144 7075-T6	U	
7	STRINGER		BAC1498-147 7075-T6	U	
8	STRINGER		BAC1505-101099 7075-T6	L	
9	STRINGER	A	BAC1506-2443 7075-T73511	L	
10	STRINGER		BAC1498-144 7075-T6	U	B
			BAC1498-145 7075-T6	U	C
11	STRINGER		BAC1498-143 7075-T6	U	B
			BAC1498-145 7075-T6	U	C

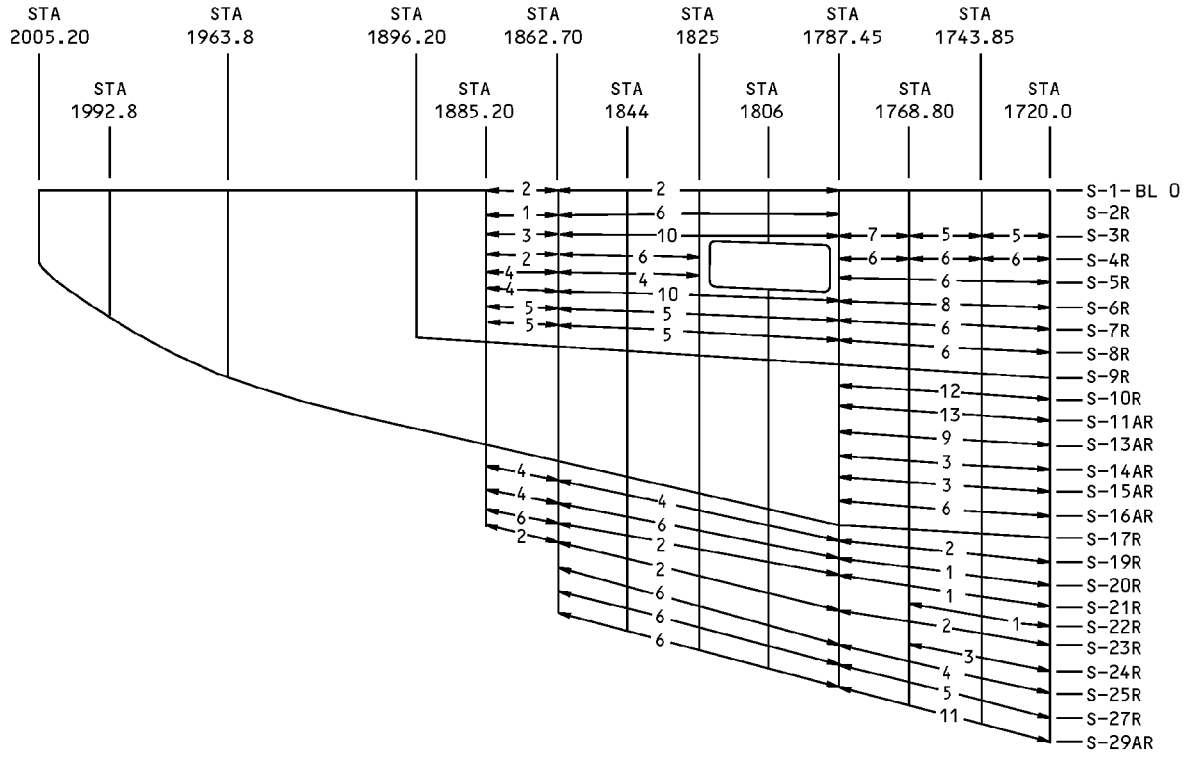
LIST OF MATERIALS FOR DETAIL I

**Section 48 Stringer Identification
Figure 1 (Sheet 3 of 5)**



757-200 STRUCTURAL REPAIR MANUAL

REF DWG
148N3131
148N3132
148N3204
148N3134
148N3123
148N3124
148N3221
148N3130



FWD →

RIGHT SIDE
DETAIL II

LIST OF
MATERIAL →

Section 48 Stringer Identification
Figure 1 (Sheet 4 of 5)

IDENTIFICATION 1
Page 4
Jan 20/2005

53-80-03

D634N201



**757-200
STRUCTURAL REPAIR MANUAL**

ITEM	DESCRIPTION	GAGE	MATERIAL	STRINGER TYPE	EFFECTIVITY
1	STRINGER		BAC1498-141 7075-T6	U	
2	STRINGER		BAC1498-143 7075-T6	U	
3	STRINGER		BAC1498-142 7075-T6	U	
4	STRINGER		BAC1498-145 7075-T6	U	
5	STRINGER		BAC1498-146 7075-T6	U	
6	STRINGER		BAC1498-144 7075-T6	U	
7	STRINGER		BAC1498-147 7075-T6	U	
8	STRINGER	A	BAC1509-100398 7075-T73511	U	
9	STRINGER		BAC1505-101099 7075-T6	T	
10	STRINGER	A	7075-T73511 EXTRUDED BAR	U	
11	STRINGER	A	BAC1506-2443 7075-T73511	U	
12	STRINGER		BAC1498-144 7075-T6	U	B
			BAC1498-145 7075-T6	U	C
13	STRINGER		BAC1498-143 7075-T6	U	B
			BAC1498-145 7075-T6	U	C

LIST OF MATERIALS FOR DETAIL II

**Section 48 Stringer Identification
Figure 1 (Sheet 5 of 5)**

IDENTIFICATION 1
Page 5
Jan 20/2005

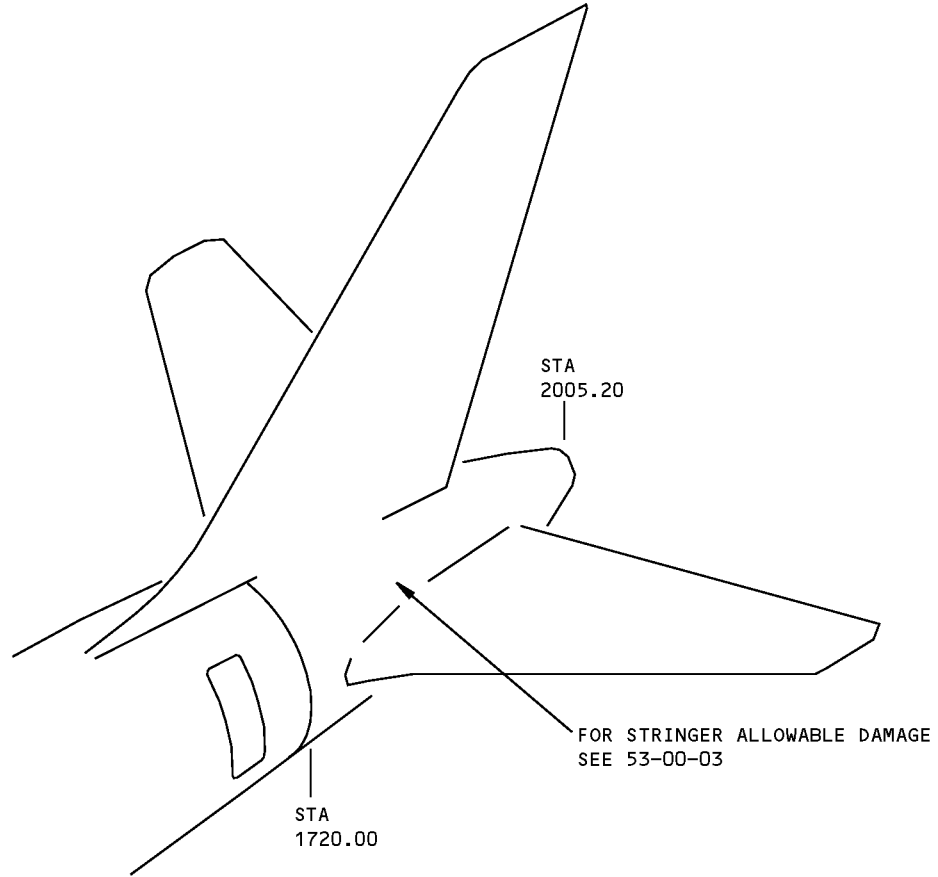
53-80-03

D634N201



757-200
STRUCTURAL REPAIR MANUAL

ALLOWABLE DAMAGE GENERAL - SECTION 48 - STRINGERS



Section 48 Stringer Allowable Damage
Figure 101

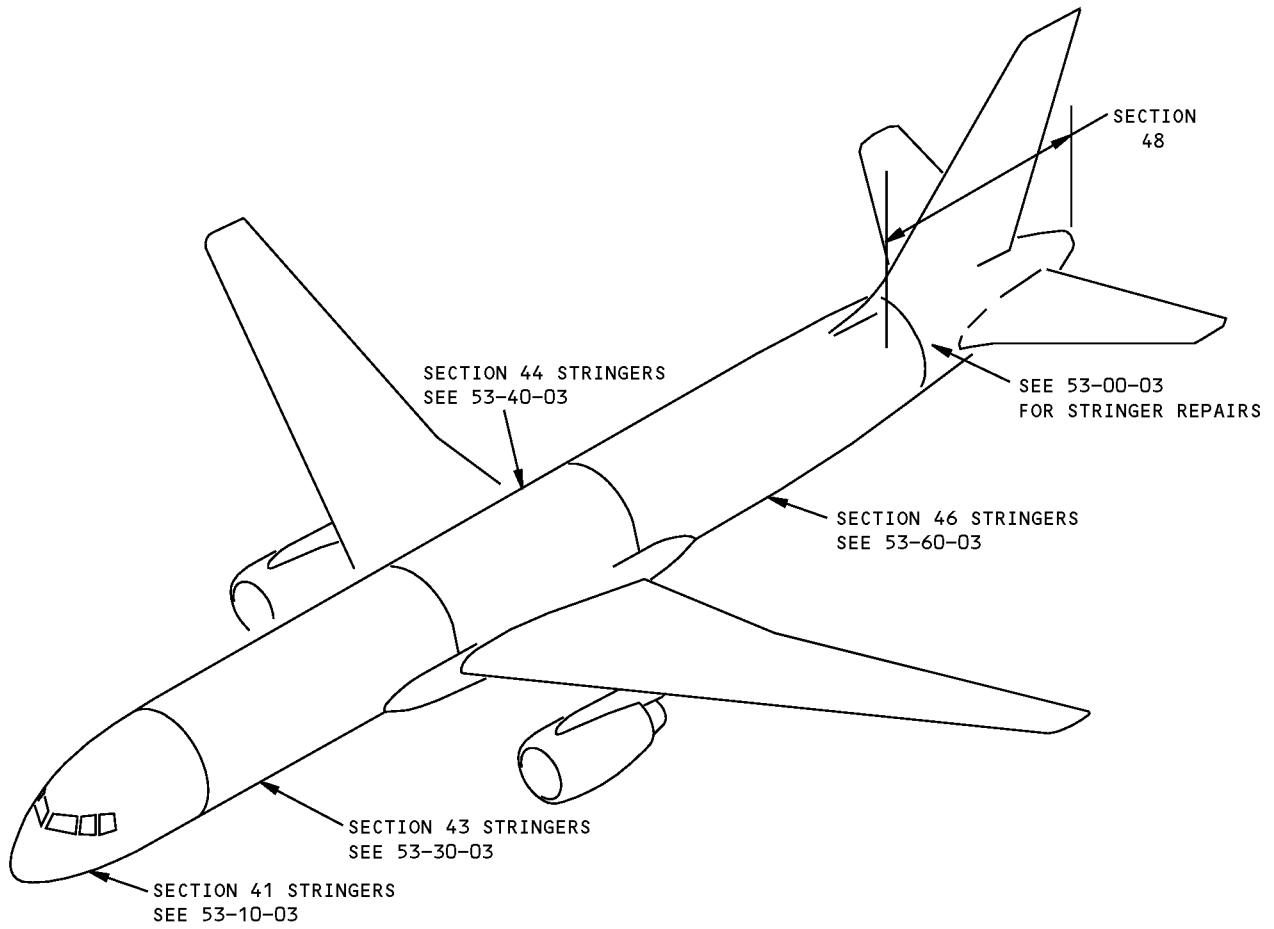
D634N201

ALLOWABLE DAMAGE GENERAL
Page 101
53-80-03 Jan 20/2005



757-200
STRUCTURAL REPAIR MANUAL

REPAIR GENERAL - SECTION 48 - STRINGERS



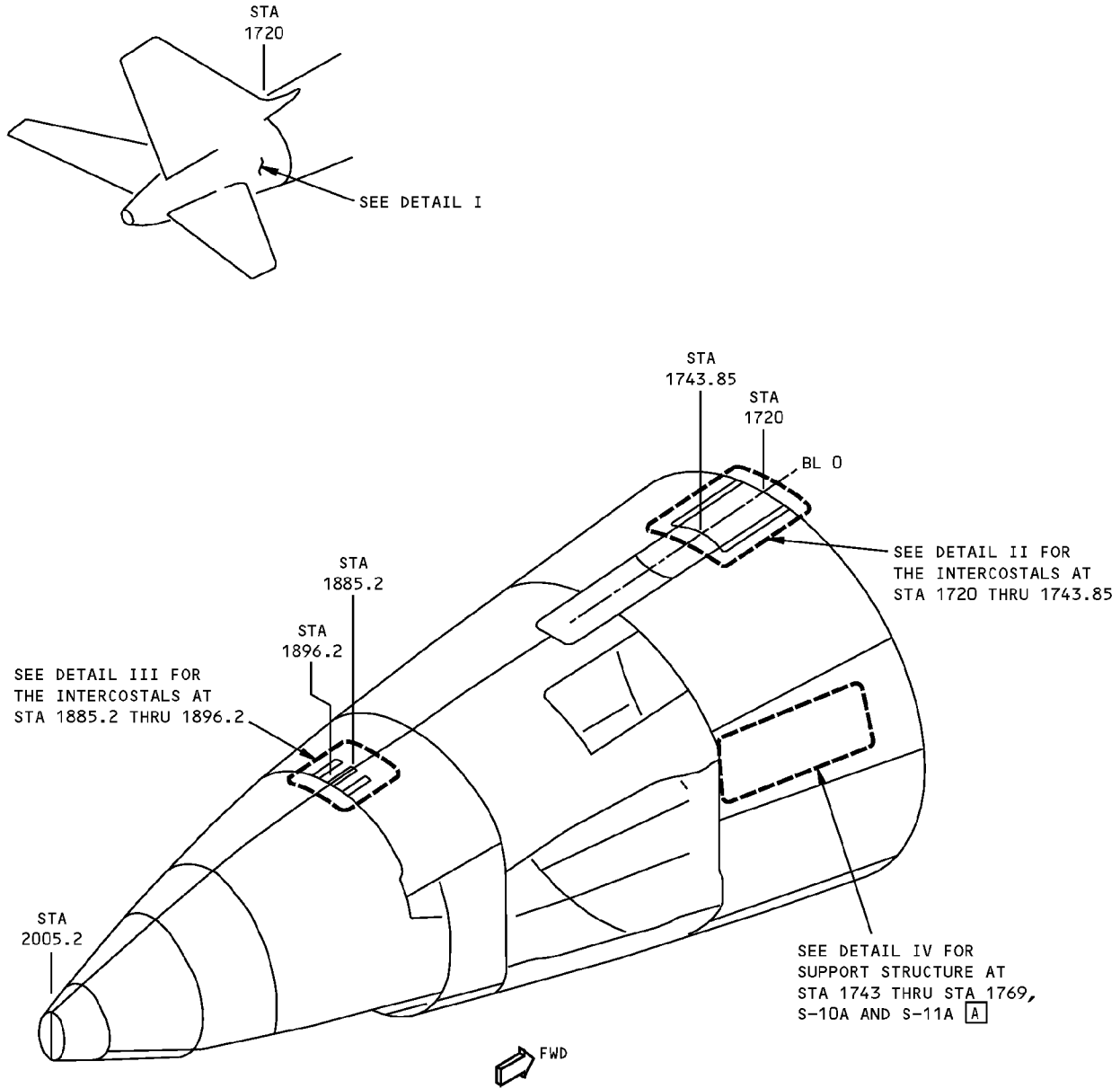
Section 48 Stringer Repair
Figure 201

D634N201

REPAIR GENERAL
Page 201
53-80-03
Jan 20/2005

**757-200
STRUCTURAL REPAIR MANUAL**

IDENTIFICATION 1 - SECTION 48 - INTERCOSTALS



DETAIL I

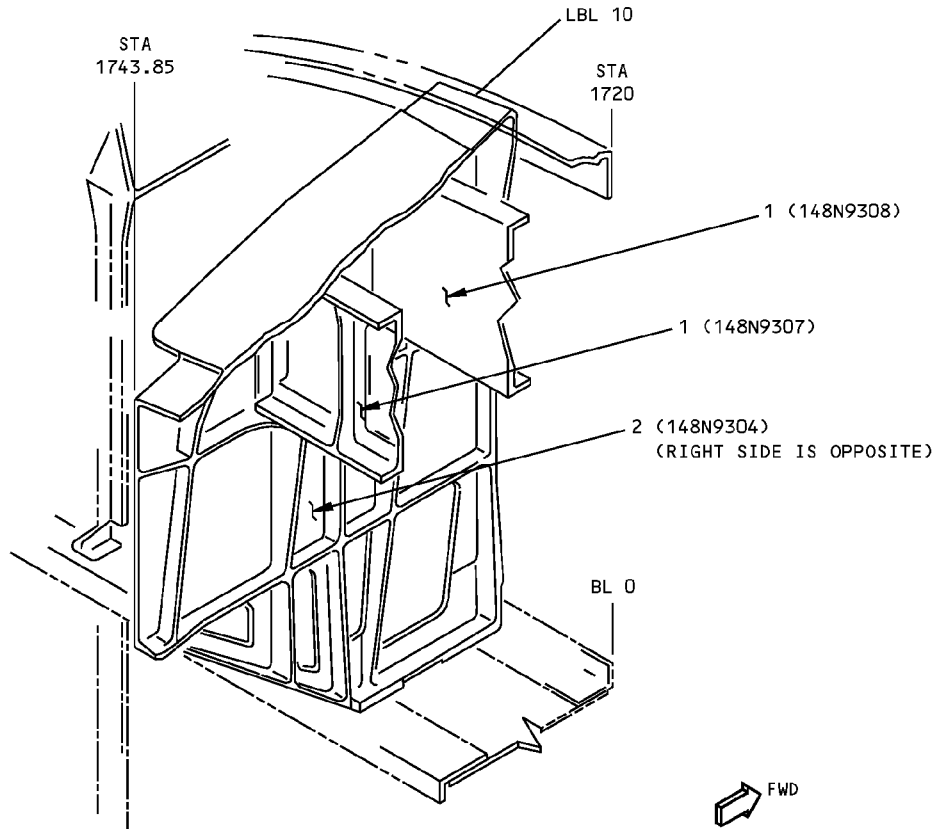
NOTES

- [A] FOR CUM LINE NUMBERS:
1 THRU 37 WITH SERVICE BULLETIN
757-53-0015 INCORPORATED

**Section 48 Intercostal Identification
Figure 1 (Sheet 1 of 4)**

**757-200
STRUCTURAL REPAIR MANUAL**

REFERENCE DRAWING
148N9301



DETAIL II

ITEM	DESCRIPTION	GAGE	MATERIAL	EFFECTIVITY
1	FITTING	2.0	7075-T73 FORGING PER BMS 7-186 OR 7075-T7351	
2	FITTING	7.0	7075-T73 FORGING PER BMS 7-186 OR 7075-T73	

LIST OF MATERIALS FOR DETAIL II

**Section 48 Intercostal Identification
Figure 1 (Sheet 2 of 4)**

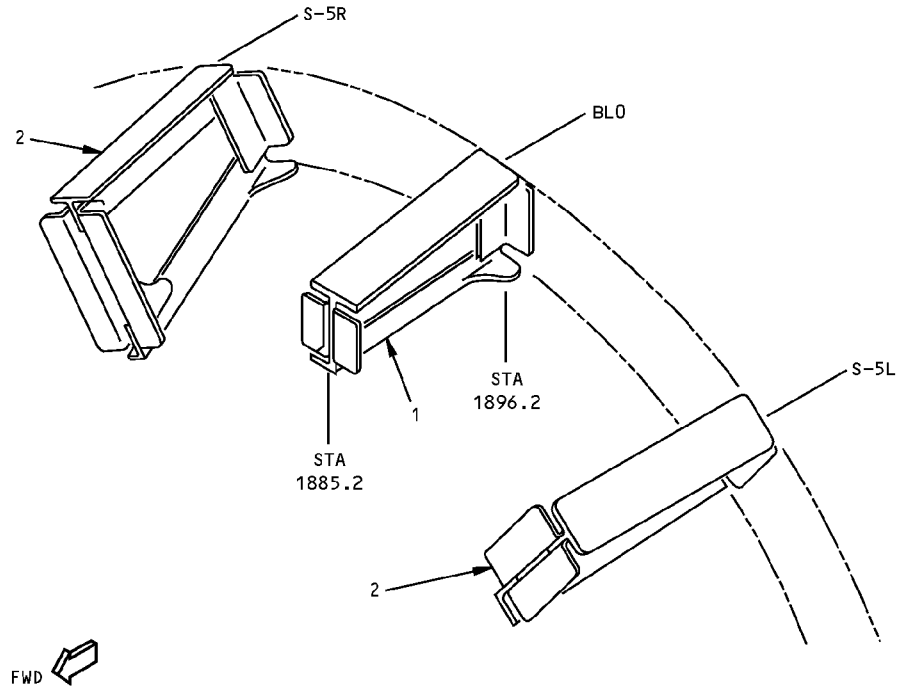
D634N201

53-80-04

IDENTIFICATION 1
Page 2
Jan 20/2005

**757-200
STRUCTURAL REPAIR MANUAL**

REFERENCE DRAWING
148N8501



DETAIL III

ITEM	DESCRIPTION	GAGE	MATERIAL	EFFECTIVITY
1	INTERCOSTAL ASSEMBLY			
	UPPER CHORD		BAC1505-100166 7075-T6511	
	LOWER CHORD		BAC1505-100166 7075-T6511	
	WEB	0.04	2024-T3	
	END CHORD	0.08	TI-6AL-4V	
2	INTERCOSTAL ASSEMBLY			
	UPPER CHORD		BAC1505-100166 7075-T6511	
	LOWER CHORD		BAC1505-100166 7075-T6511	
	WEB	0.05	2024-T3	
	END CHORD	0.08	TI-6AL-4V	
	END CHORD		AND10136-2401 7075-T6511	

LIST OF MATERIALS FOR DETAIL III

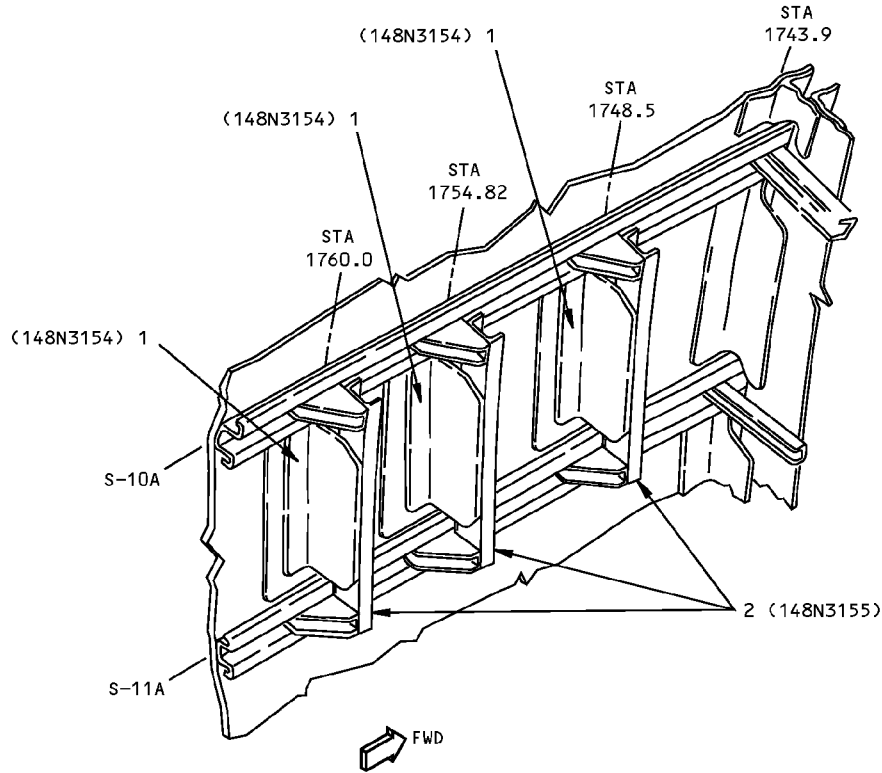
**Section 48 Intercostal Identification
Figure 1 (Sheet 3 of 4)**

IDENTIFICATION 1
Page 3
Jan 20/2005

53-80-04

D634N201

**757-200
STRUCTURAL REPAIR MANUAL**



LEFT SIDE IS SHOWN, RIGHT SIDE IS OPPOSITE
DETAIL IV

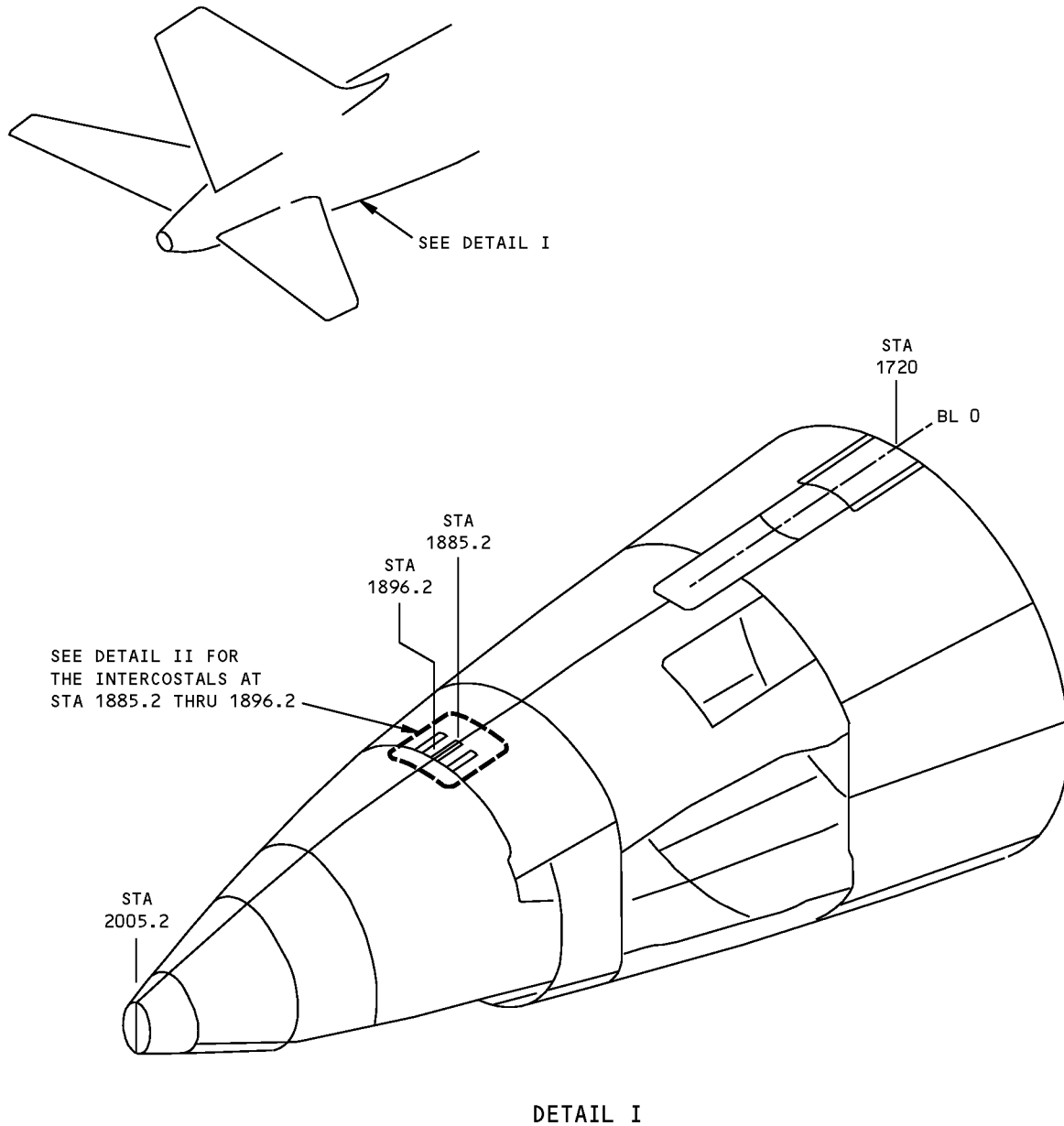
ITEM	DESCRIPTION	GAGE	MATERIAL	EFFECTIVITY
1	CHANNEL		AND10137-1401 7075-T6511	A
2	REINFORCING ANGLE	0.063	CLAD 7075-T6	A

LIST OF MATERIALS FOR DETAIL IV

**Section 48 Intercostal Identification
Figure 1 (Sheet 4 of 4)**

**757-200
STRUCTURAL REPAIR MANUAL**

ALLOWABLE DAMAGE GENERAL - SECTION 48 - INTERCOSTALS



NOTES

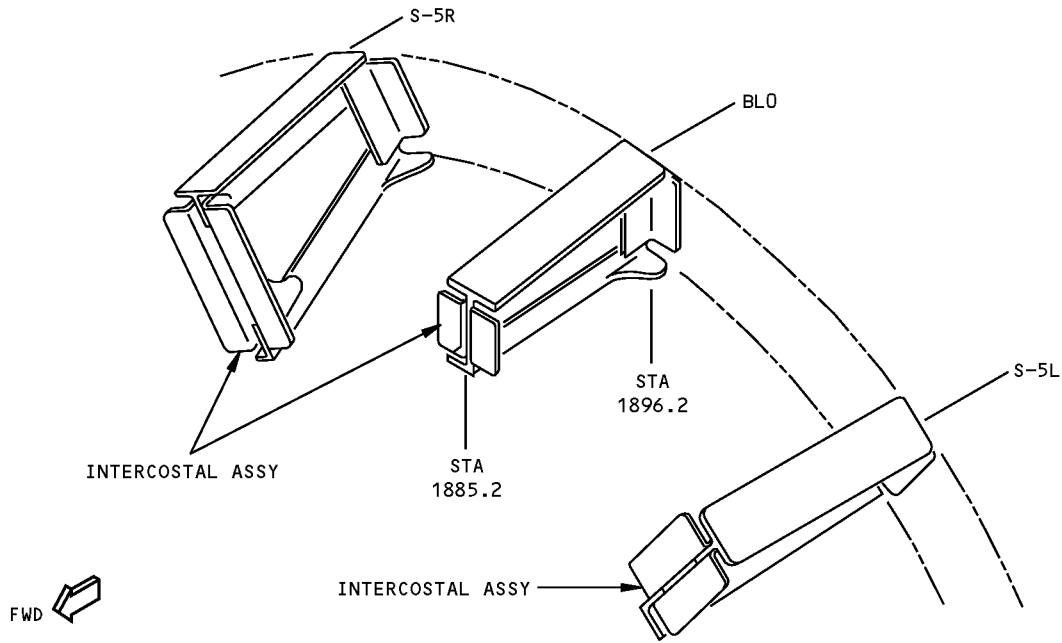
- REFER TO SRM 53-00-04 FOR THE INTERCOSTAL ALLOWABLE DAMAGE DATA

**Section 48 Intercostal Allowable Damage
Figure 101 (Sheet 1 of 2)**

D634N201

**757-200
STRUCTURAL REPAIR MANUAL**

REF DWG
148N8501

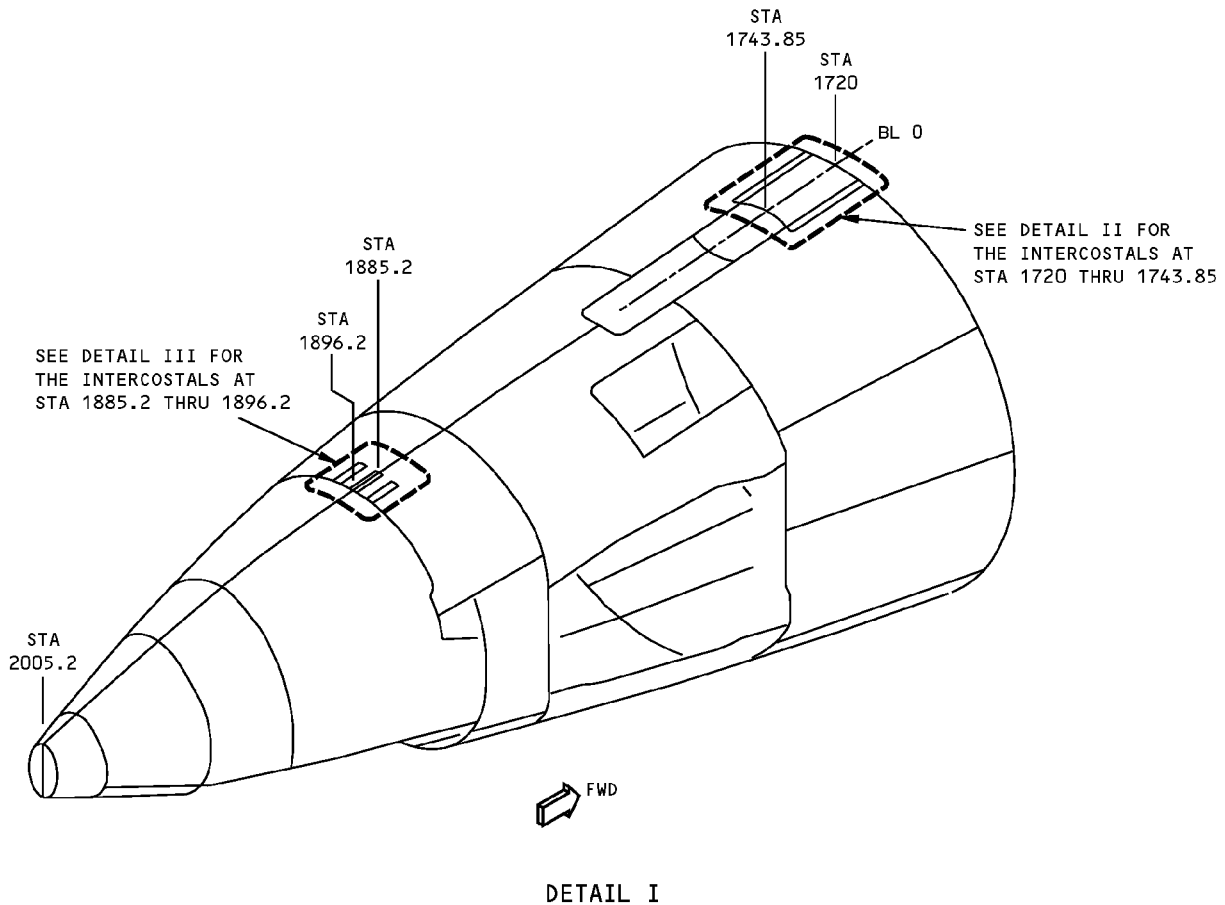
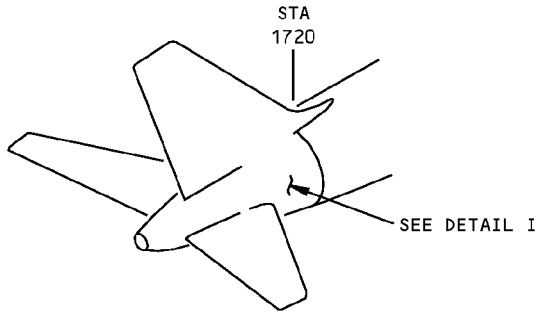


DETAIL II

**Section 48 Intercostal Allowable Damage
Figure 101 (Sheet 2 of 2)**

**757-200
STRUCTURAL REPAIR MANUAL**

REPAIR GENERAL - SECTION 48 - INTERCOSTAL



NOTES

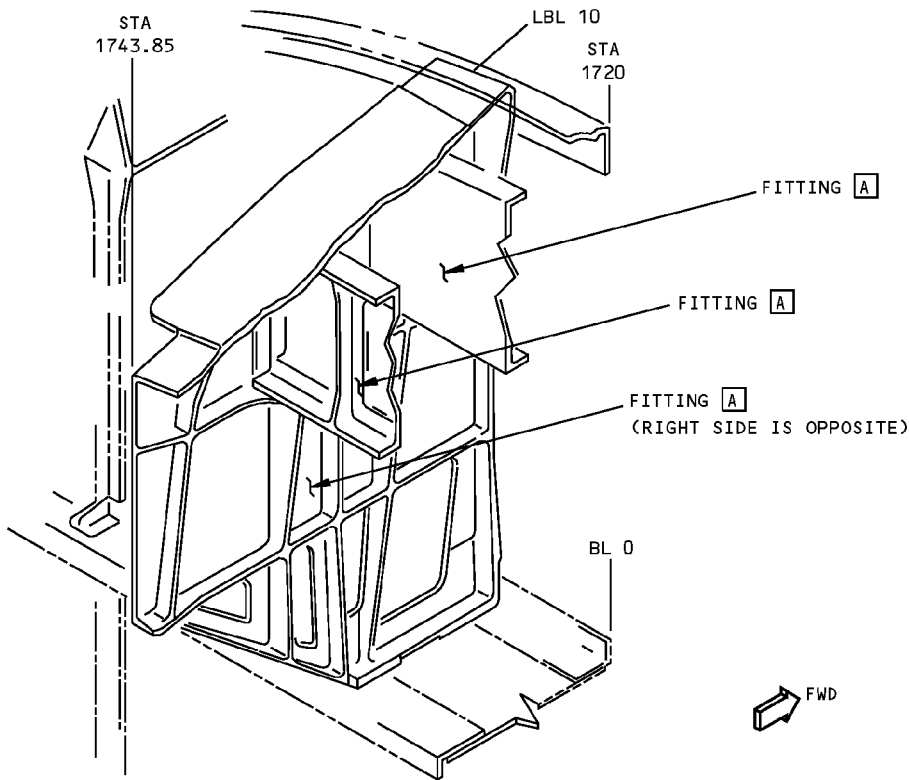
A NO TYPICAL REPAIR TO FITTINGS APPLICABLE. SPECIFIC REPAIRS TO FITTINGS WILL BE PROVIDED BASED ON SERVICE EXPERIENCE.

B DAMAGED COMPONENTS MAY BE REPLACED OR REPAIRED. IF REPAIRS ARE TO BE MADE, REFER TO SRM 51-70 FOR TYPICAL WEB, FORMED SECTION, OR EXTRUDED SECTION REPAIR.

**Section 48 Fuselage Intercostal Repair
Figure 201 (Sheet 1 of 2)**

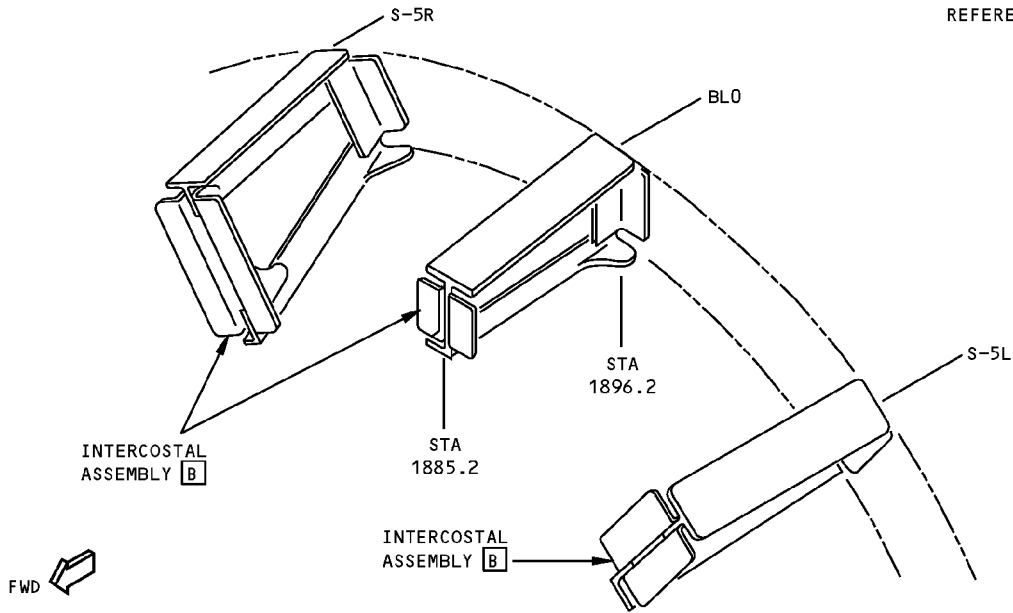
**757-200
STRUCTURAL REPAIR MANUAL**

REFERENCE DRAWING
148N9301



DETAIL II

REFERENCE DRAWING
148N8501



DETAIL III

**Section 48 Fuselage Intercostal Repair
Figure 201 (Sheet 2 of 2)**

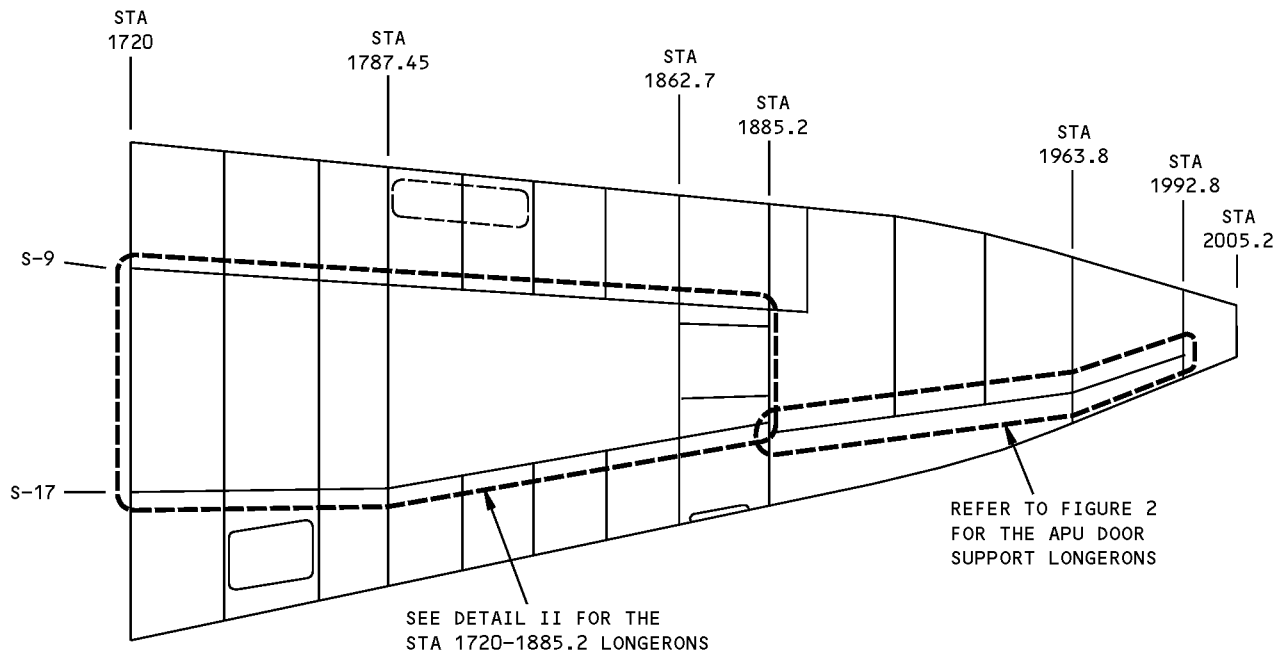
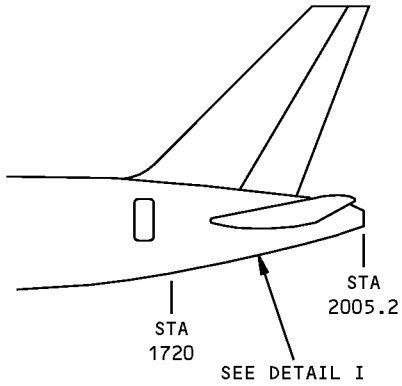
REPAIR GENERAL
Page 202
Jan 20/2005

53-80-04

D634N201

**757-200
STRUCTURAL REPAIR MANUAL**

IDENTIFICATION 1 - SECTION 48 - LONGERONS

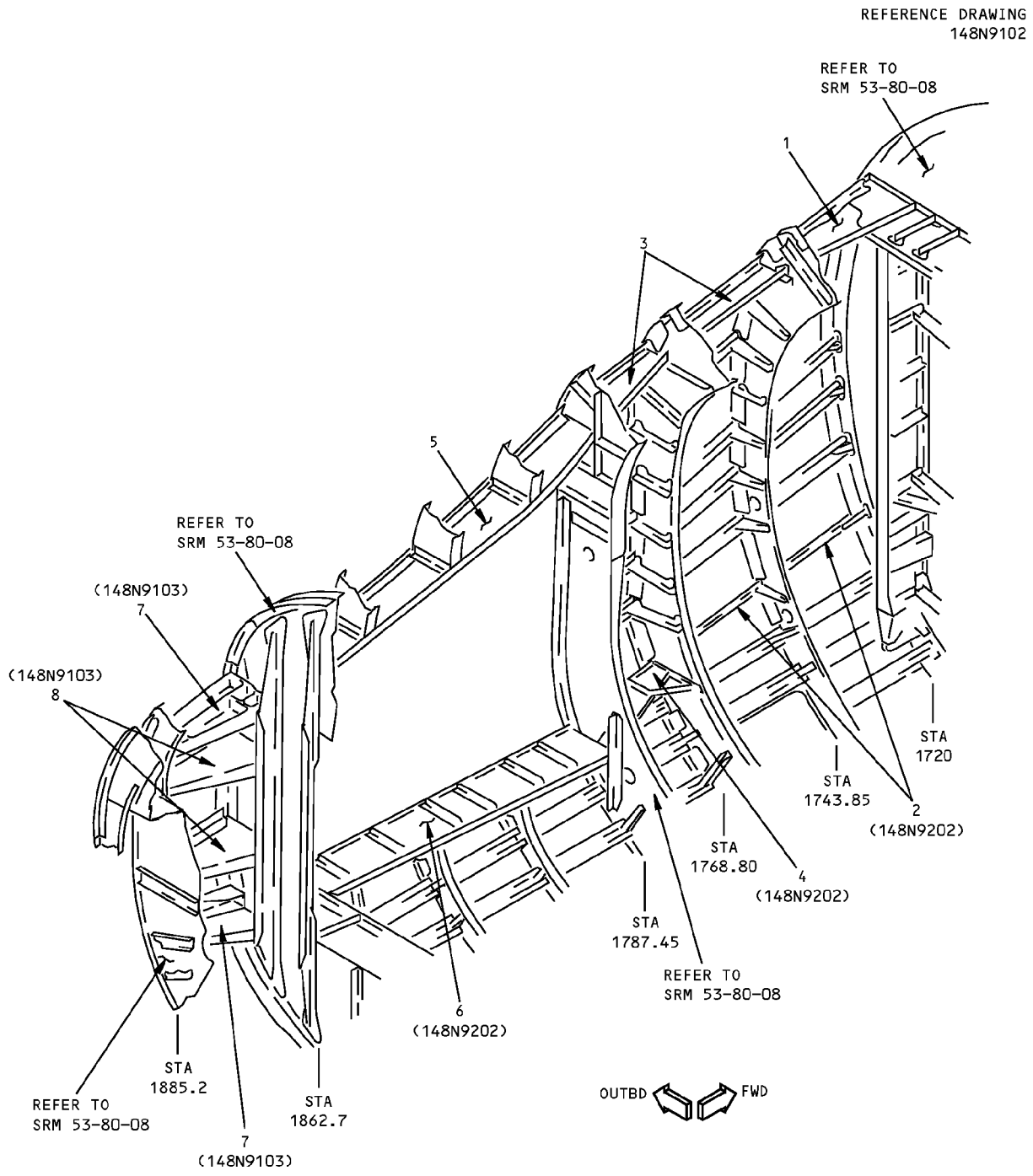


LEFT SIDE VIEW
SECTION 48

DETAIL I

**Section 48 Longeron Identification
Figure 1 (Sheet 1 of 3)**

**757-200
STRUCTURAL REPAIR MANUAL**



DETAIL II

LIST OF
MATERIAL

**Section 48 Longeron Identification
Figure 1 (Sheet 2 of 3)**



**757-200
STRUCTURAL REPAIR MANUAL**

ITEM	DESCRIPTION	GAGE	MATERIAL	EFFECTIVITY
1	UPR LONGERON			
	UPR OUTER CHORD	0.08	7075-T6	
	LWR OUTER CHORD	0.08	7075-T6	
	WEB	0.09	CHEM-MILLED 7075-T6	
	INNER CHORD		BAC1503-100133 7075-T62	
2	LWR LONGERON			
	UPR OUTER CHORD	0.08	7075-T6	
	LWR OUTER CHORD	0.08	7075-T6	
3	UPR LONGERON			
	UPR OUTER CHORD	0.08	7075-T6	
	LWR OUTER CHORD	0.08	7075-T6	
	WEB	0.04	7075-T6	
	INNER CHORD		BAC1503-100133 7075-T62	
4	LWR LONGERON			
	UPR OUTER CHORD	0.08	7075-T6	
	LWR OUTER CHORD	0.08	7075-T6	
	WEB	0.063	CLAD 7075-T6	
	INNER CHORD		BAC1503-100215 7075-T6511	
5	UPR LONGERON			
	UPR OUTER CHORD	0.08	7075-T62	
	LWR OUTER CHORD	0.08	7075-T62	
	WEB	0.04	7075-T6	
	INNER CHORD		BAC1503-100215 7075-T62	
6	LWR LONGERON			
	UPR OUTER CHORD	0.08	7075-T6	
	LWR OUTER CHORD	0.08	7075-T6	
	WEB	0.04	CLAD 7075-T6	
	INNER CHORD		BAC1503-100434 7075-T6511	
7	LONGERON			
	FITTING	5.0	7050-T73652 FORGED BLOCK	
	FITTING	4.0	7050-T73652 FORGED BLOCK	
8	LONGERON			
	FITTING	4.0	7050-T73652 FORGED BLOCK	
	CHORD		AND10136-3005 7075-T62	

LIST OF MATERIALS FOR DETAIL II

**Section 48 Longeron Identification
Figure 1 (Sheet 3 of 3)**

D634N201

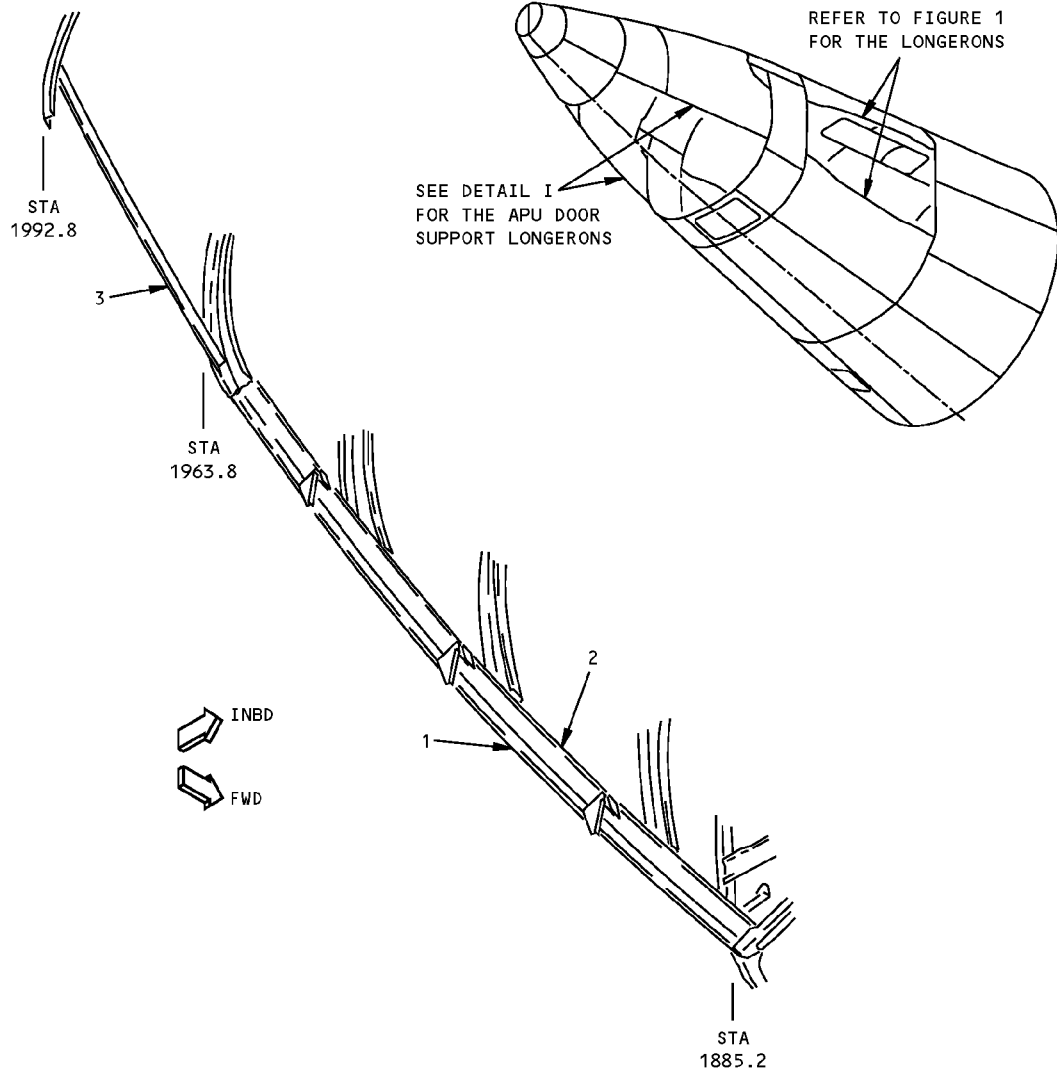
53-80-05

IDENTIFICATION 1
Page 3
Jan 20/2005

**757-200
STRUCTURAL REPAIR MANUAL**

IDENTIFICATION 2 - SECTION 48 - APU DOOR SUPPORT LONGERON

REFERENCE DRAWING
148N8201



DETAIL I

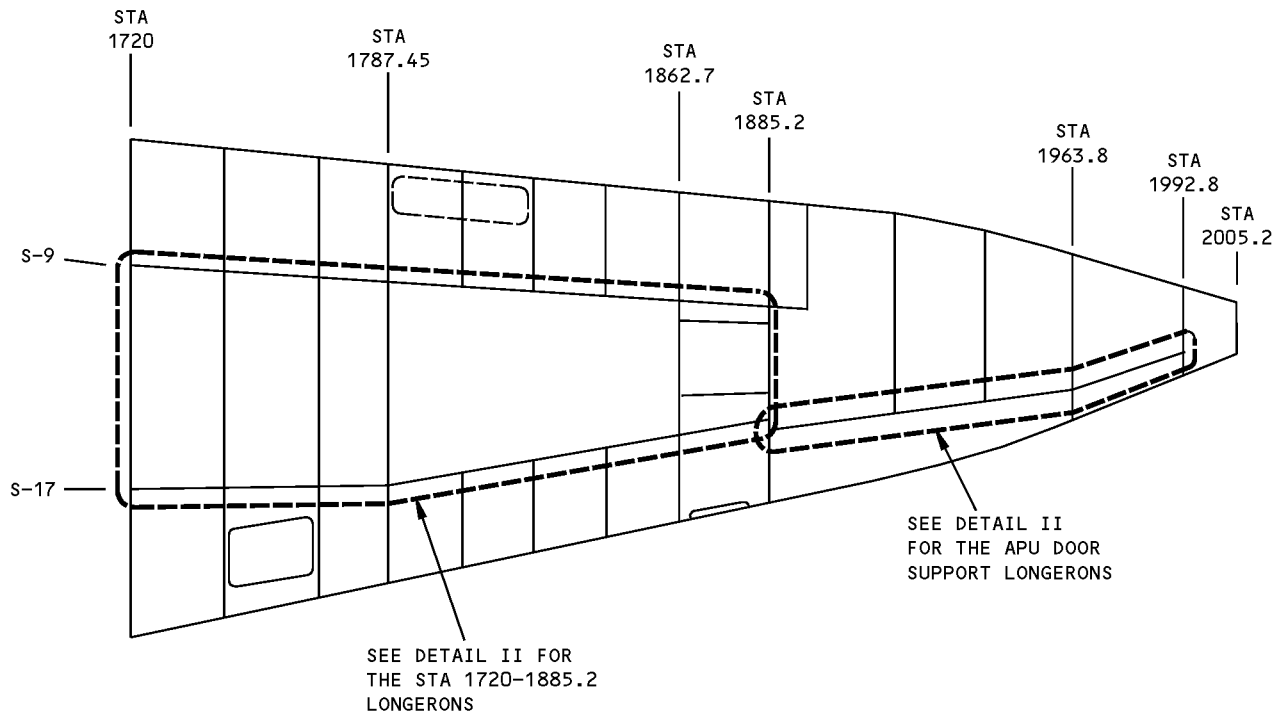
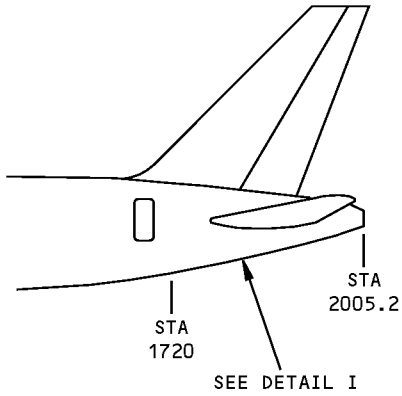
ITEM	DESCRIPTION	GAGE	MATERIAL	EFFECTIVITY
1	CHORD - FORWARD		BAC1505-100252 2024-T42	
2	WEB	0.05	CLAD 2024-T42	
3	CHORD - AFT		BAC1505-100252 2024-T42	

LIST OF MATERIALS FOR DETAIL I

**Section 48 APU Door Support Longeron Identification
Figure 1**

**757-200
STRUCTURAL REPAIR MANUAL**

ALLOWABLE DAMAGE 1 - SECTION 48 - LONGERONS



**LEFT SIDE VIEW
SECTION 48**

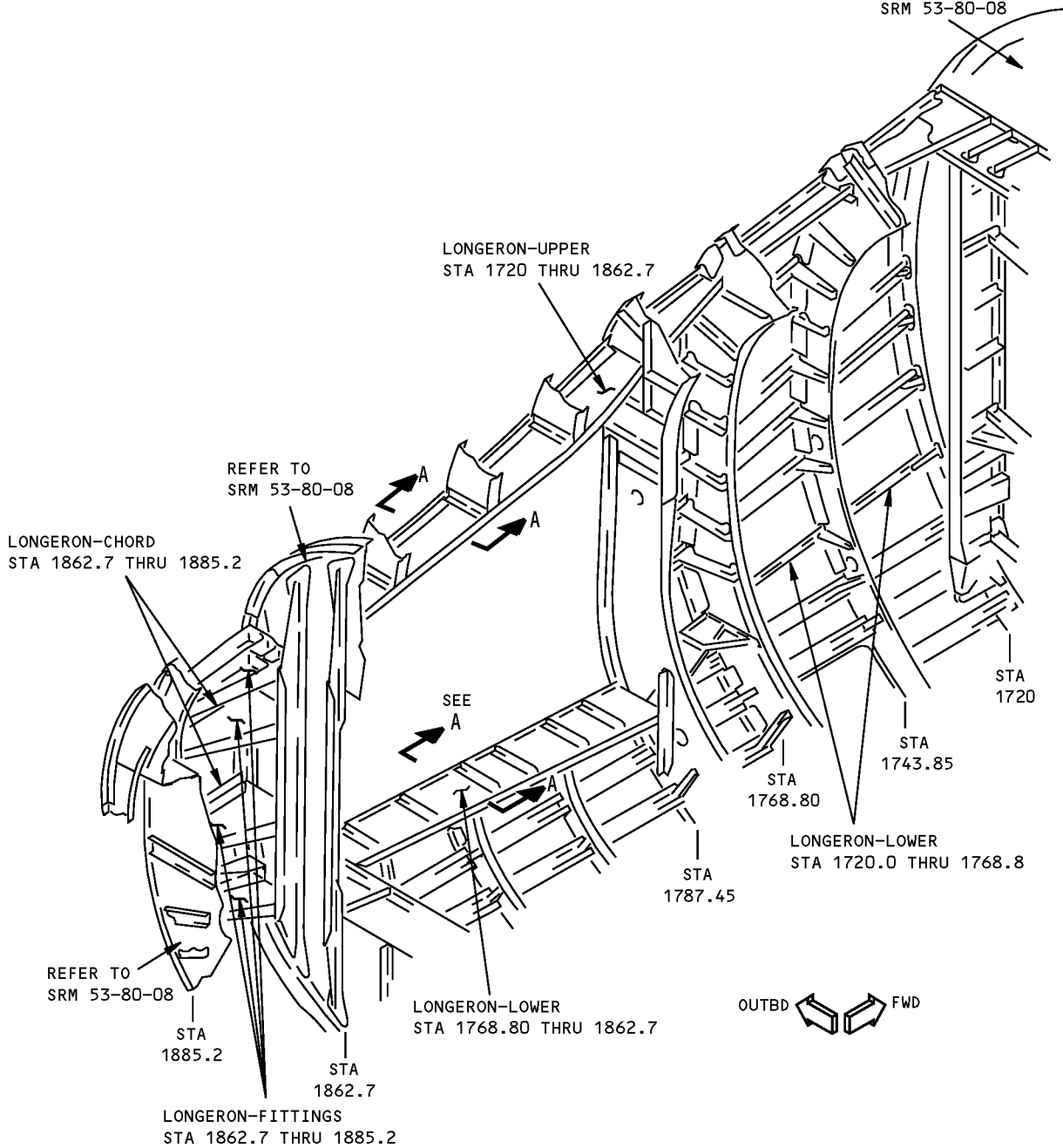
DETAIL I

**Section 48 Longeron Allowable Damage
Figure 101 (Sheet 1 of 7)**

**757-200
STRUCTURAL REPAIR MANUAL**

REFERENCE DRAWINGS
148N9102
148N9103
148N9202

REFER TO
SRM 53-80-08

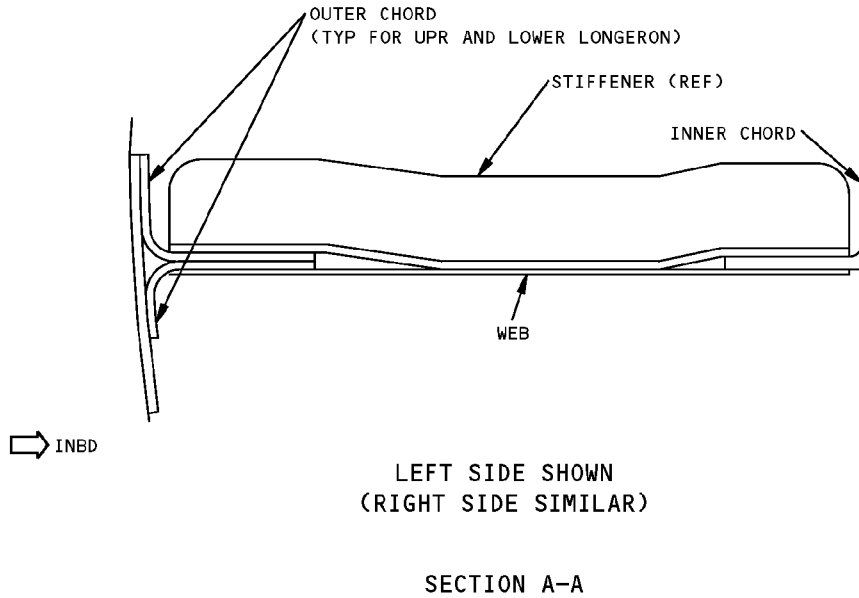


MATERIAL: ALUMINUM

DETAIL II

**Section 48 Longeron Allowable Damage
Figure 101 (Sheet 2 of 7)**

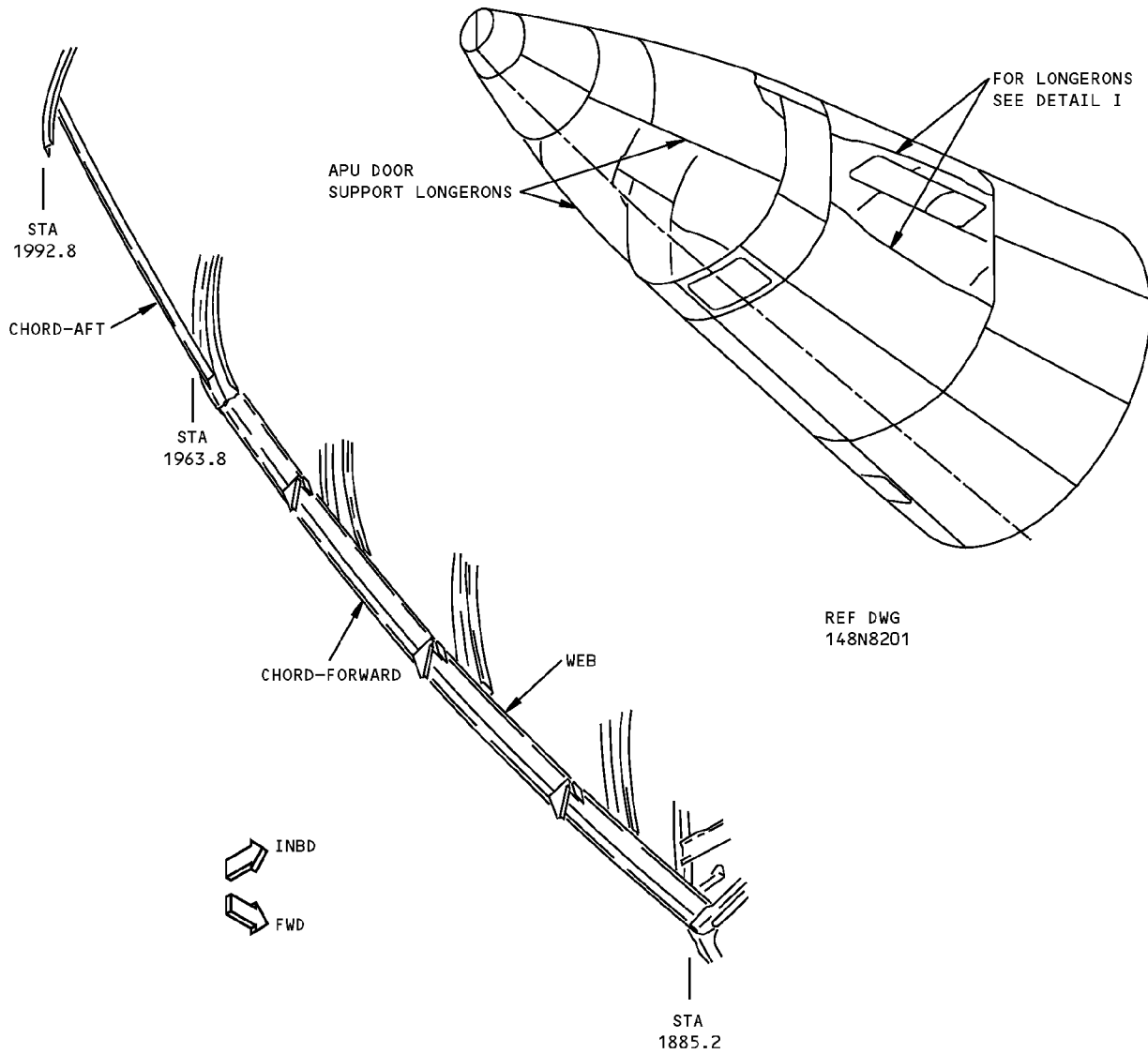
**757-200
STRUCTURAL REPAIR MANUAL**



STATION	ITEM	CRACKS	NICKS, GOUGES AND CORROSION	DENTS	HOLES AND PUNCTURES
1720.0 THRU 1862.7	LONGERON - UPR UPR & LWR, OUTER CHORD (FORMED)	A	E	NOT ALLOWED	NOT ALLOWED
	WEB	C	F	SEE DETAIL VI	H
	INNER CHORD (EXTRUDED)	B	D	NOT ALLOWED	NOT ALLOWED
1720.0 THRU 1768.8	LONGERON - LWR UPR & LWR, OUTER CHORD (FORMED)	A	E	NOT ALLOWED	NOT ALLOWED
1768.8 THRU 1862.7	LONGERON - LWR UPR & LWR, OUTER CHORD (FORMED)	A	E	NOT ALLOWED	NOT ALLOWED
	WEB	C	F	SEE DETAIL VI	H
	INNER CHORD (EXTRUDED)	B	D	NOT ALLOWED	NOT ALLOWED
1862.7 THRU 1885.2	LONGERON FITTING (FORGED)	G	G	NOT ALLOWED	NOT ALLOWED
	CHORD (EXTRUDED)	G	G	NOT ALLOWED	NOT ALLOWED

**Section 48 Longeron Allowable Damage
Figure 101 (Sheet 3 of 7)**

**757-200
STRUCTURAL REPAIR MANUAL**



MATERIAL: ALUMINUM

DETAIL III

DESCRIPTION	CRACKS	NICKS, GOUGES AND CORROSION	DENTS	HOLES AND PUNCTURES
CHORD - FWD (EXTRUDED)	B	D	NOT PERMITTED	NOT PERMITTED
WEB	A	E	I	J
CHORD - AFT (EXTRUDED)	B	D	NOT PERMITTED	NOT PERMITTED

**Section 48 Longeron Allowable Damage
Figure 101 (Sheet 4 of 7)**



757-200

STRUCTURAL REPAIR MANUAL

NOTES

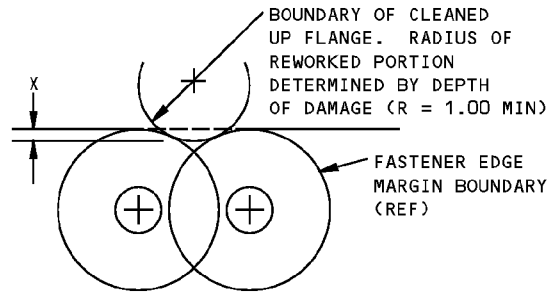
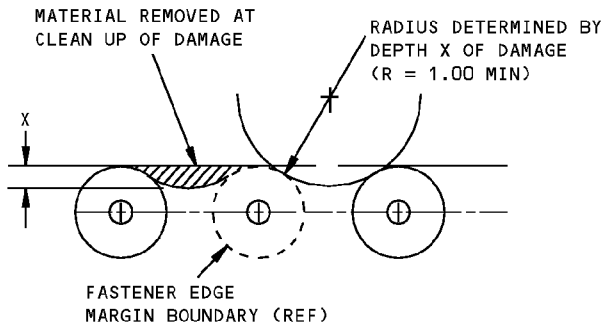
- REFER TO AMM 51-20 TO APPLY THE FINISH TO THE REWORKED AREA.
- A** CRACKS ARE NOT PERMITTED EXCEPT FOR EDGE CRACKS WHICH MUST BE REMOVED AS SHOWN ON DETAILS IV AND X.
- B** CRACKS ARE NOT PERMITTED EXCEPT FOR EDGE CRACKS WHICH MUST BE REMOVED AS SHOWN ON DETAILS IV AND IX.
- C** CRACKS ARE NOT PERMITTED EXCEPT FOR EDGE CRACKS WHICH MUST BE REMOVED AS SHOWN ON DETAILS IV AND VIII.
- D** REMOVE DAMAGE AS SHOWN ON DETAILS IV, V AND IX.
- E** REMOVE THE DAMAGE AS SHOWN ON DETAILS IV, V, VII, AND X.
- F** REMOVE THE DAMAGE AS SHOWN ON DETAILS IV, V, VII, AND VIII.
- G** REMOVE THE DAMAGE AS SHOWN IN DETAILS IV, V, AND IX. SHOT PEEN REWORKED AREAS AS GIVEN IN SOPM 20-10-03 AND SRM 51-20-06 WITH SHOT NO. 230-550. SHOT PEEN INTENSITIES WILL VARY WITH THE THICKNESS REMAINING AFTER REWORK.
- H** HOLES ARE PERMITTED TO A MAXIMUM OF 0.25 INCH IN DIAMETER IF THEY ARE A MINIMUM OF 1.0 INCH AWAY FROM A FASTENER HOLE, AN EDGE, OR OTHER DAMAGE. FILL THE HOLE WITH A 2117-T3 OR T-4 ALUMINUM PROTRUDING HEAD RIVET. INSTALL THE RIVET WITHOUT SEALANT.
- I** DENTS ARE NOT PERMITTED IN THE FLANGE OF A WEB. REFER TO DETAIL VI FOR DENTS IN OTHER AREAS OF THE WEB.
- J** HOLES ARE NOT PERMITTED IN THE FLANGE OF A WEB. HOLES THAT ARE IN OTHER AREAS OF A WEB MUST BE REWORKED. REFER TO **H**.

**Section 48 Longeron Allowable Damage
Figure 101 (Sheet 5 of 7)**

D634N201

ALLOWABLE DAMAGE 1
53-80-05
Page 105
Jan 20/2005

**757-200
STRUCTURAL REPAIR MANUAL**

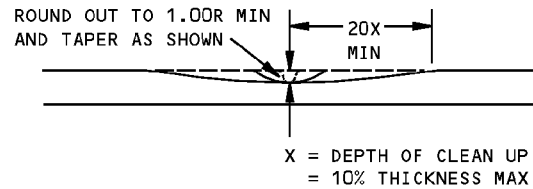
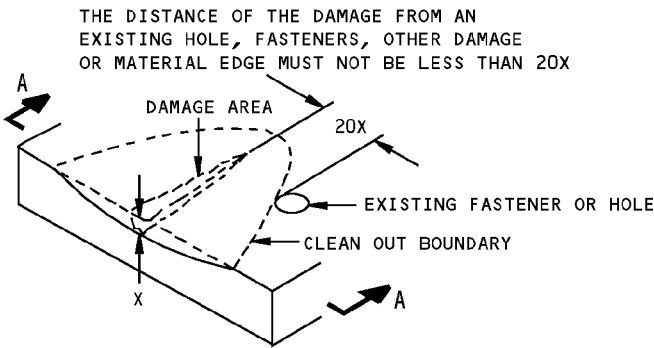


DEPTH X = 0.10 MAX OR 10% OF FLANGE WIDTH, WHICHEVER IS LESS

DAMAGE CLEAN UP OF EDGES WHERE FASTENER EDGE MARGINS DO NOT OVERLAP

DAMAGE CLEAN UP OF EDGES WHERE FASTENER EDGE MARGINS OVERLAP

DETAIL IV

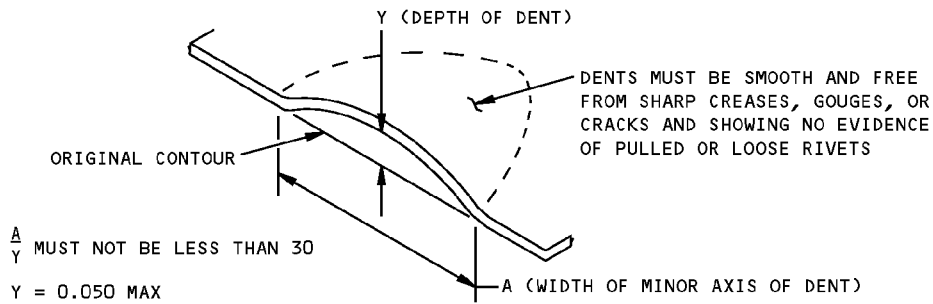


THE MAXIMUM AREA REMOVED FOR DAMAGE CLEANUP SHALL NOT EXCEED 4% OF THE ORIGINAL CROSS-SECTIONAL AREA

SECTION A-A

REMOVAL OF NICK, GOUGE AND SCRATCH DAMAGE ON A SURFACE

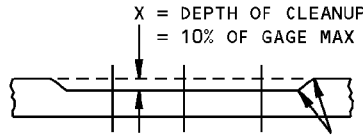
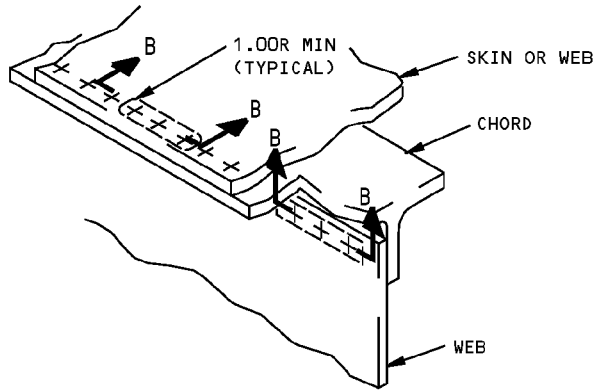
DETAIL V



ALLOWABLE DAMAGE FOR DENT
DETAIL VI

**Section 48 Longerons Allowable Damage
Figure 101 (Sheet 6 of 7)**

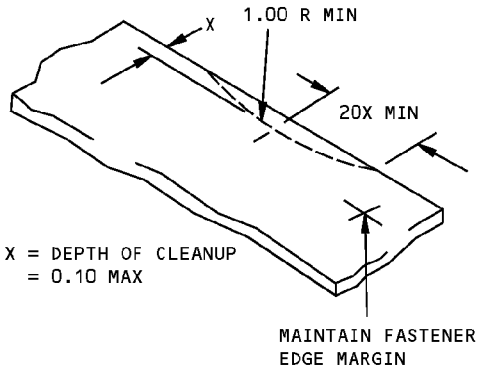
**757-200
STRUCTURAL REPAIR MANUAL**



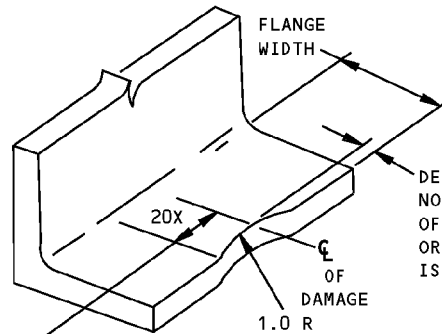
SMOOTH BLEND-OUT RADIUS 0.50 INCH MINIMUM. CORROSION CLEANUP AROUND ANY THREE FASTENERS IN TEN IS PERMITTED TO MAX DEPTH 10% OF MATERIAL THICKNESS

SECTION B-B

CORROSION CLEANUP
DETAIL VII

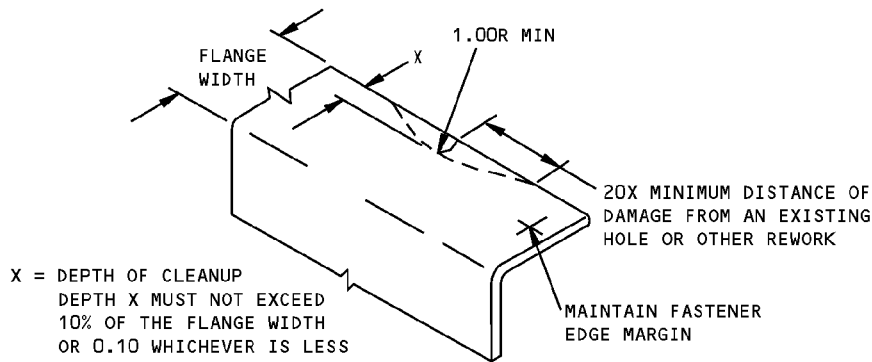


REMOVAL OF NICK OR CRACK
DAMAGE ON AN EDGE
DETAIL VIII



THE DISTANCE OF THE DAMAGE
FROM AN EXISTING HOLE, FASTENERS,
OTHER DAMAGE OR EDGE MUST NOT BE
LESS THAN 20X

REMOVAL OF EDGE DAMAGE FROM
FREE FLANGE WITHOUT FASTENERS
DETAIL IX

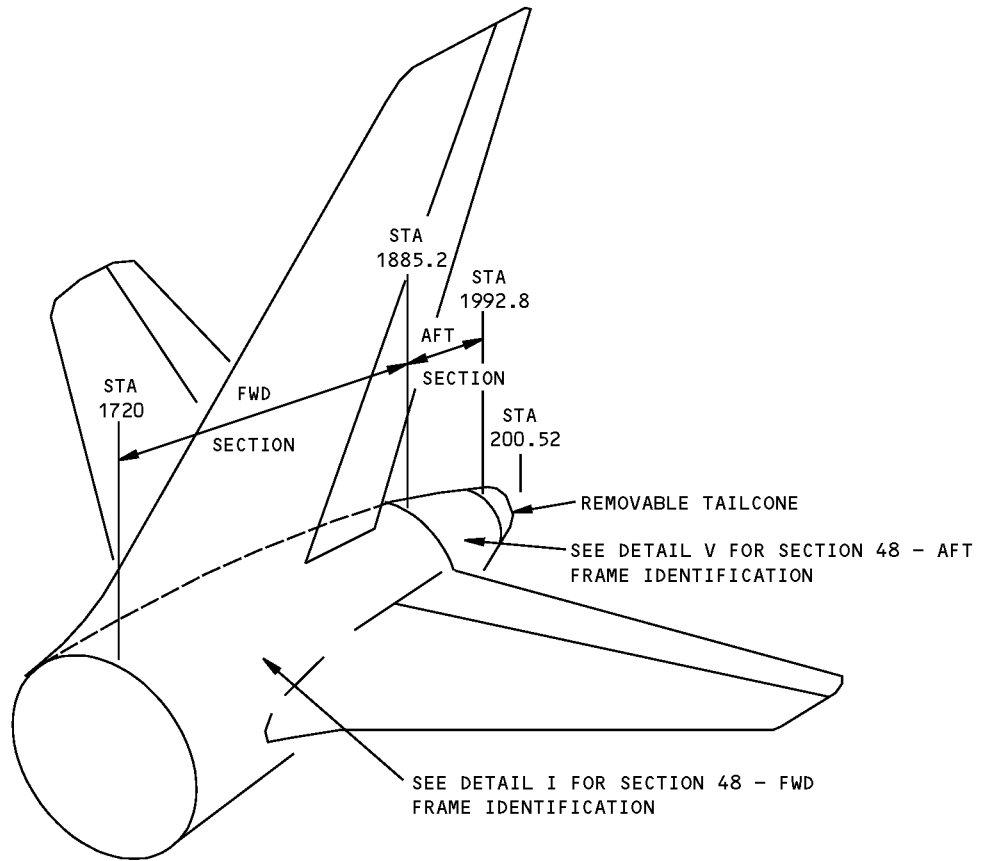


DAMAGE CLEANUP OF FLANGES
DETAIL X

**Section 48 Longerons Allowable Damage
Figure 101 (Sheet 7 of 7)**

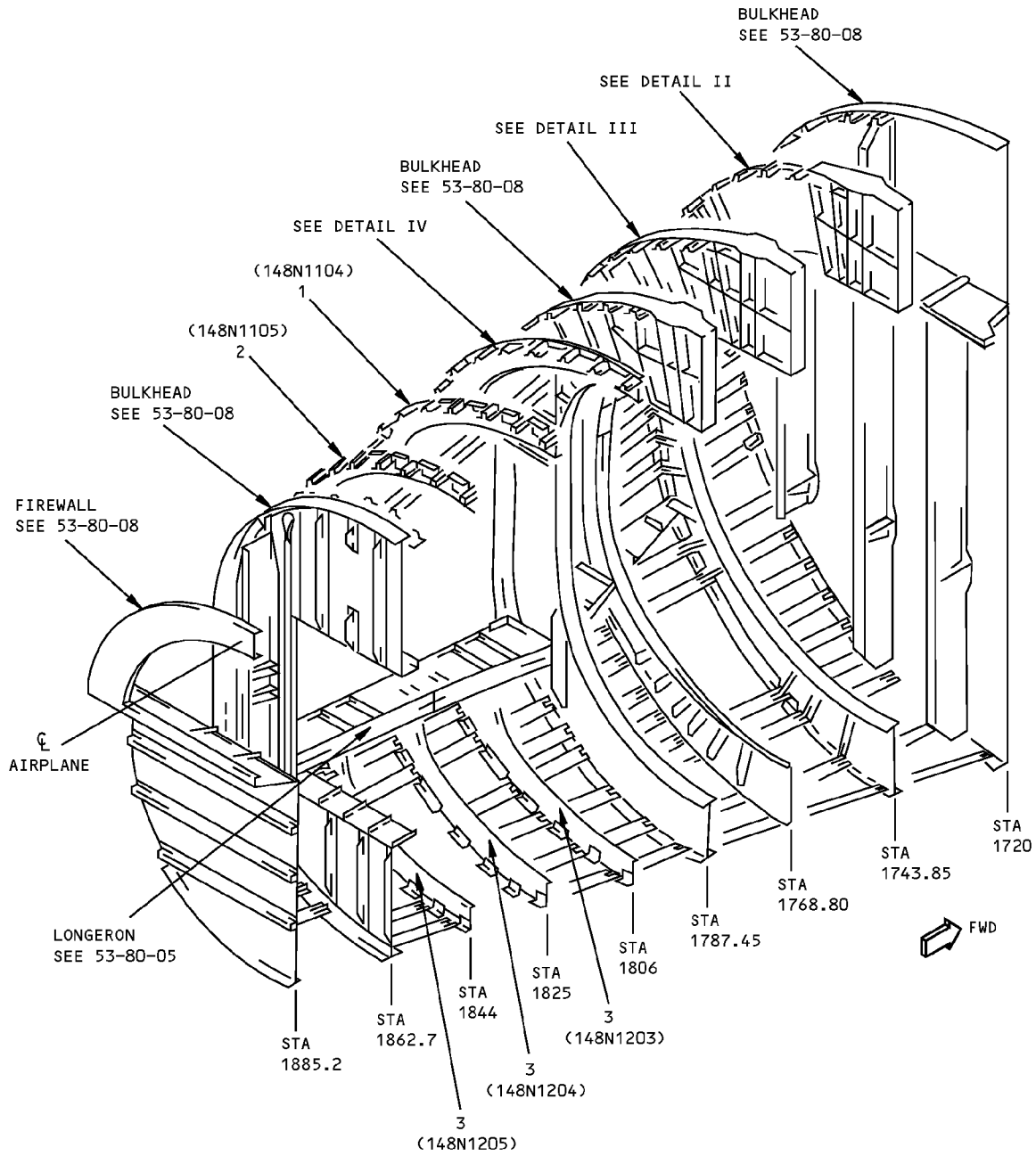
757-200
STRUCTURAL REPAIR MANUAL

IDENTIFICATION 1 - SECTION 48 - FRAMES



Section 48 Frame Identification
Figure 1 (Sheet 1 of 8)

**757-200
STRUCTURAL REPAIR MANUAL**



**FORWARD SECTION
DETAIL I**

LIST OF
MATL →

**Section 48 Frame Identification
Figure 1 (Sheet 2 of 8)**



**757-200
STRUCTURAL REPAIR MANUAL**

ITEM	DESCRIPTION	GAGE	MATERIAL	EFFECTIVITY
1	UPPER FRAME OUTER CHORD WEB - LEFT SIDE WEB - RIGHT SIDE INNER CHORD	0.05 0.08	BAC1490-2583 CLAD 7075-T73 CLAD 7075-T62 7075-T6 AND10136-2004 7075-T73	
2	UPPER FRAME OUTER CHORD WEB	0.05	BAC1490-2631 CLAD 7075-T73 CLAD 7075-T6	
3	LOWER FRAME OUTER CHORD WEB INNER CHORD	0.063 0.05 0.05	CLAD 7075-T62 CLAD 7075-T62 CLAD 7075-T62	

LIST OF MATERIALS FOR DETAIL I

**Section 48 Frame Identification
Figure 1 (Sheet 3 of 8)**

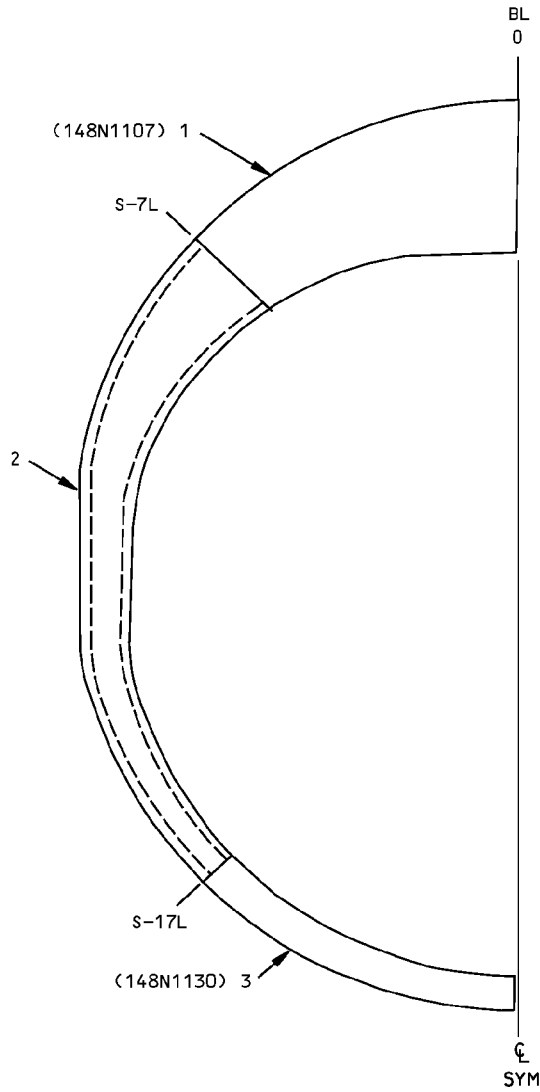
D634N201

53-80-07

IDENTIFICATION 1
Page 3
Jan 20/2005

**757-200
STRUCTURAL REPAIR MANUAL**

REF DWG
148N1101



FRAME - STA 1743.85
REAR VIEW
DETAIL II

ITEM	DESCRIPTION	GAGE	MATERIAL	EFFECTIVITY
1	FORGING		7175-T736	
2	FRAME ASSY OUTER CHORD WEB INNER CHORD	0.100	AND10133-2004 7075-T73 7075-T6 AND10133-3006 7075-T73	
3	CHANNEL	0.072	7075-T6	

LIST OF MATERIALS FOR DETAIL II

**Section 48 Frame Identification
Figure 1 (Sheet 4 of 8)**

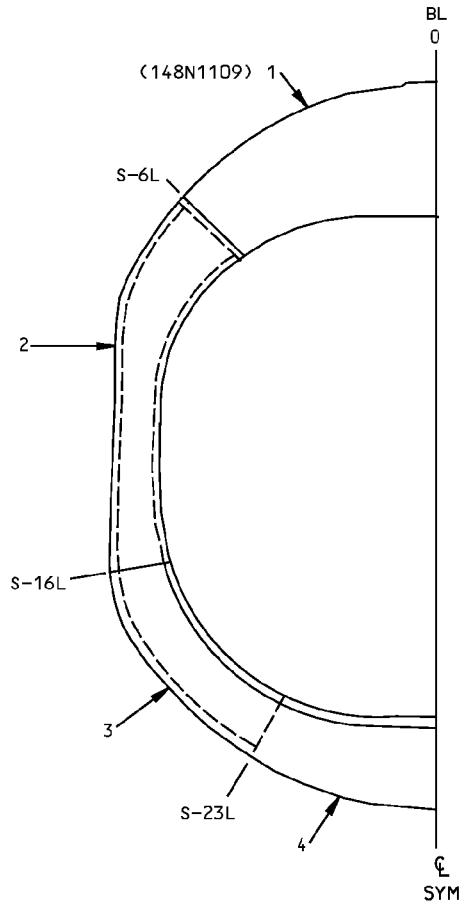
IDENTIFICATION 1
Page 4
Jan 20/2005

53-80-07

D634N201

**757-200
STRUCTURAL REPAIR MANUAL**

REF DWG
148N1102



**FRAME - STA 1768.80
REAR VIEW
DETAIL III**

ITEM	DESCRIPTION	GAGE	MATERIAL	EFFECTIVITY
1	FORGING		7175-T736	
2	FRAME ASSY OUTER CHORD WEB INNER CHORD	0.100	AND10134-2404 7075-T73 7075-T6 AND10136-3006 7075-T73	
3	FRAME ASSY OUTER CHORD WEB WEB INNER CHORD FAILSAFE CHORD	0.063 0.100	AND10134-2404 7075-T73 7075-T6 7075-T6 AND10136-3006 7075-T73 AND10133-2004 7075-T73	
4	FRAME ASSY FITTING WEB FAILSAFE CHORD	1.80 0.063	7075-T7351 7075-T6 AND10133-2004 7075-T73	

LIST OF MATERIALS FOR DETAIL III

**Section 48 Frame Identification
Figure 1 (Sheet 5 of 8)**

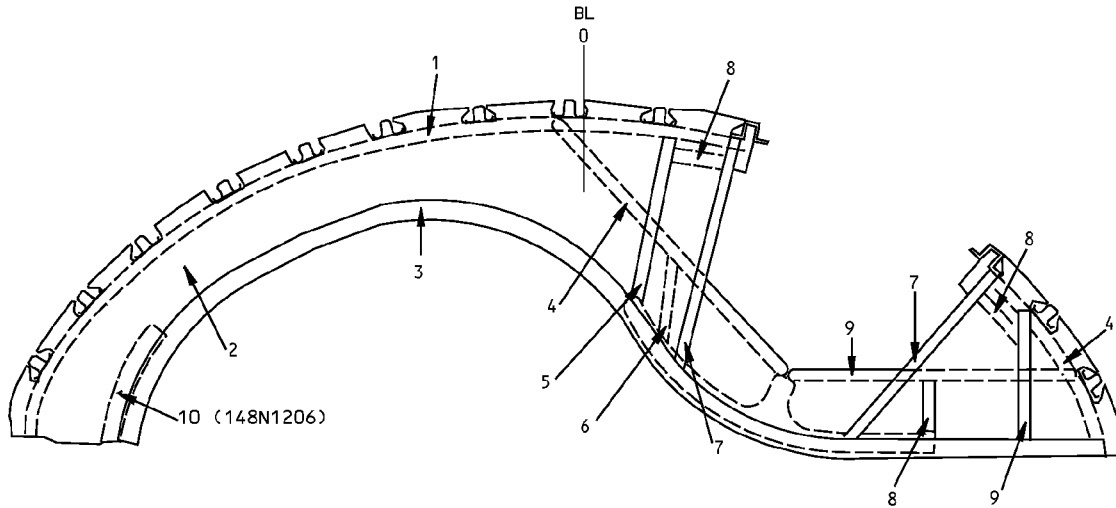
IDENTIFICATION 1
Page 5
Jan 20/2005

53-80-07

D634N201

**757-200
STRUCTURAL REPAIR MANUAL**

REF DWG
148N1103



FRAME - STA 1806
REAR VIEW
DETAIL IV

ITEM	DESCRIPTION	GAGE	MATERIAL	EFFECTIVITY
1	OUTER CHORD		BAC1490-64 CLAD 7075-T73	
2	WEB	0.05	CLAD 7075-T73	
3	INNER CHORD	0.063	CLAD 7075-T73	
4	CHORD		BAC1490-2522 CLAD 7075-T73	
5	STIFFENER		AND10134-1201 7075-T6511	
6	STIFFENER		AND10134-1204 7075-T6511	
7	CHORD		BAC1505-100350 7075-T6511	
8	STIFFENER		AND10133-0701 7075-T6511	
9	CHORD		BAC1490-2631 CLAD 7075-T73	
10	ANGLE	0.063	CLAD 7075-T62	

LIST OF MATERIALS FOR DETAIL IV

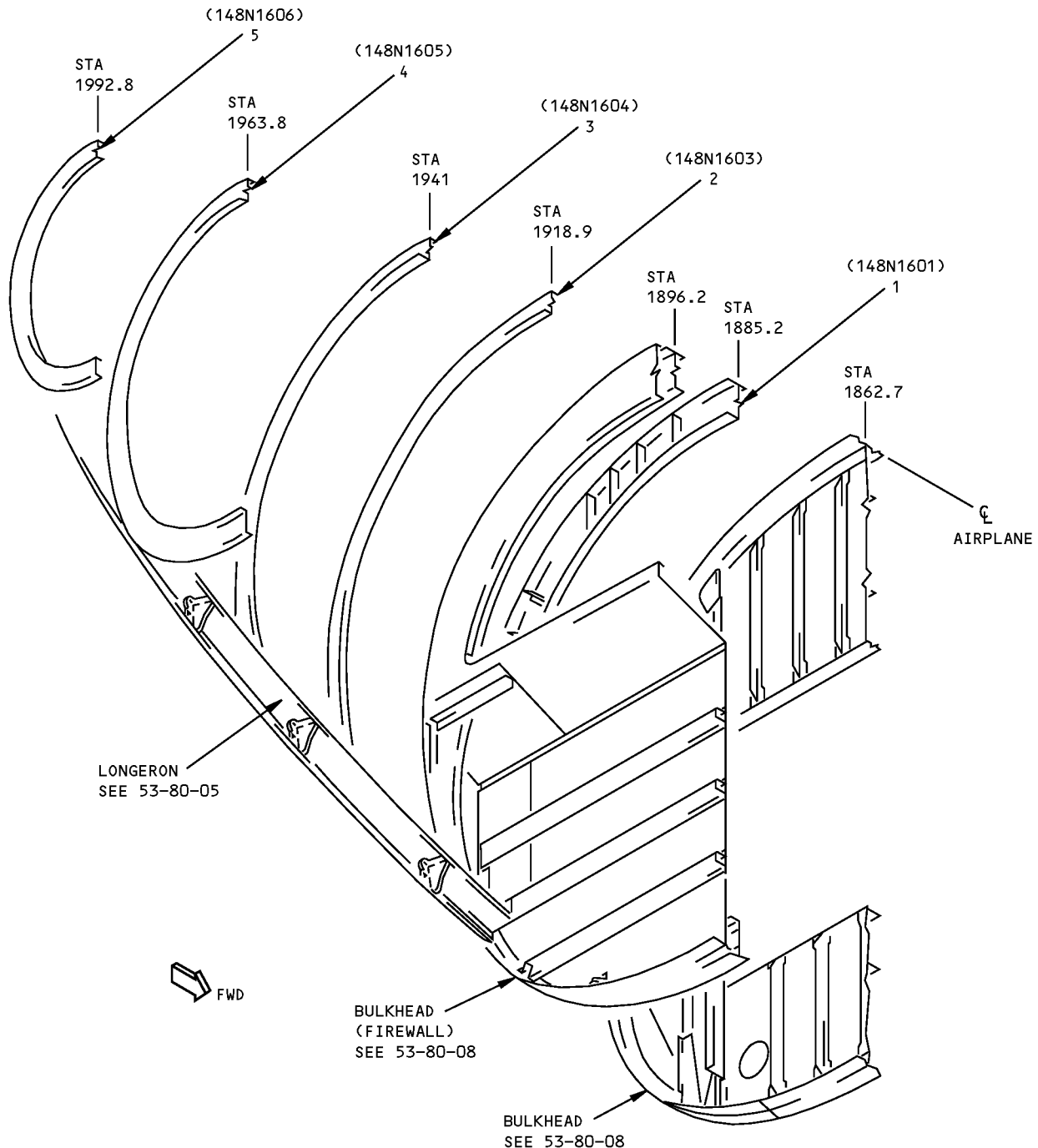
**Section 48 Frame Identification
Figure 1 (Sheet 6 of 8)**

IDENTIFICATION 1
Page 6
Jan 20/2005

53-80-07

D634N201

**757-200
STRUCTURAL REPAIR MANUAL**



DETAIL V

LIST OF
MATL

**Section 48 Frame Identification
Figure 1 (Sheet 7 of 8)**



757-200
STRUCTURAL REPAIR MANUAL

ITEM	DESCRIPTION	GAGE	MATERIAL	EFFECTIVITY
1	FRAME OUTER CHORD WEB INNER CHORD	0.04	BAC1505-10008 7075-T6 7075-T6 BAC1505-100261 7075-T6	
2	FRAME OUTER CHORD WEB	0.05	BAC1503-100366 2024-T3511 CLAD 2024-T42	
3	FRAME OUTER CHORD WEB	0.05	BAC1506-3159 2024-T3511 CLAD 2024-T42	
4	FRAME OUTER CHORD WEB	0.05	BAC1505-100544 2024-T42 2024-T42	
5	FRAME FRAME RING	0.05 0.05	2024-T42 2024-T3	

LIST OF MATERIALS FOR DETAIL V

Section 48 Frame Identification
Figure 1 (Sheet 8 of 8)

D634N201

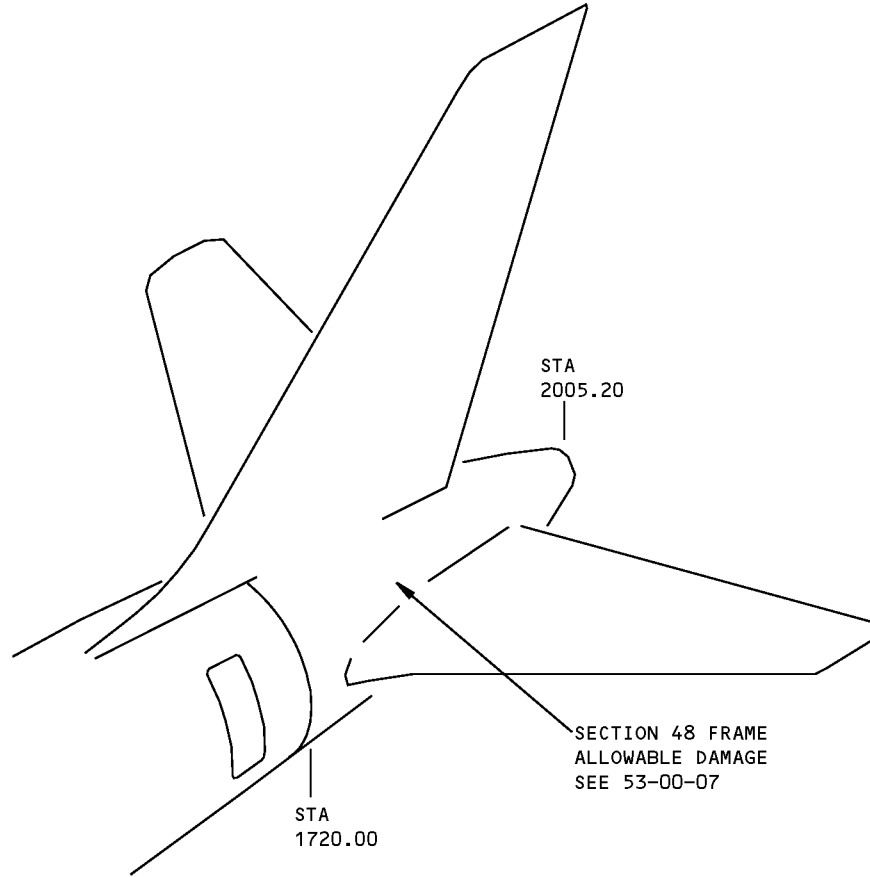
53-80-07

IDENTIFICATION 1
Page 8
Jan 20/2005



757-200
STRUCTURAL REPAIR MANUAL

ALLOWABLE DAMAGE GENERAL - SECTION 48 - FRAMES



Section 48 Fuselage Frames Allowable Damage
Figure 101

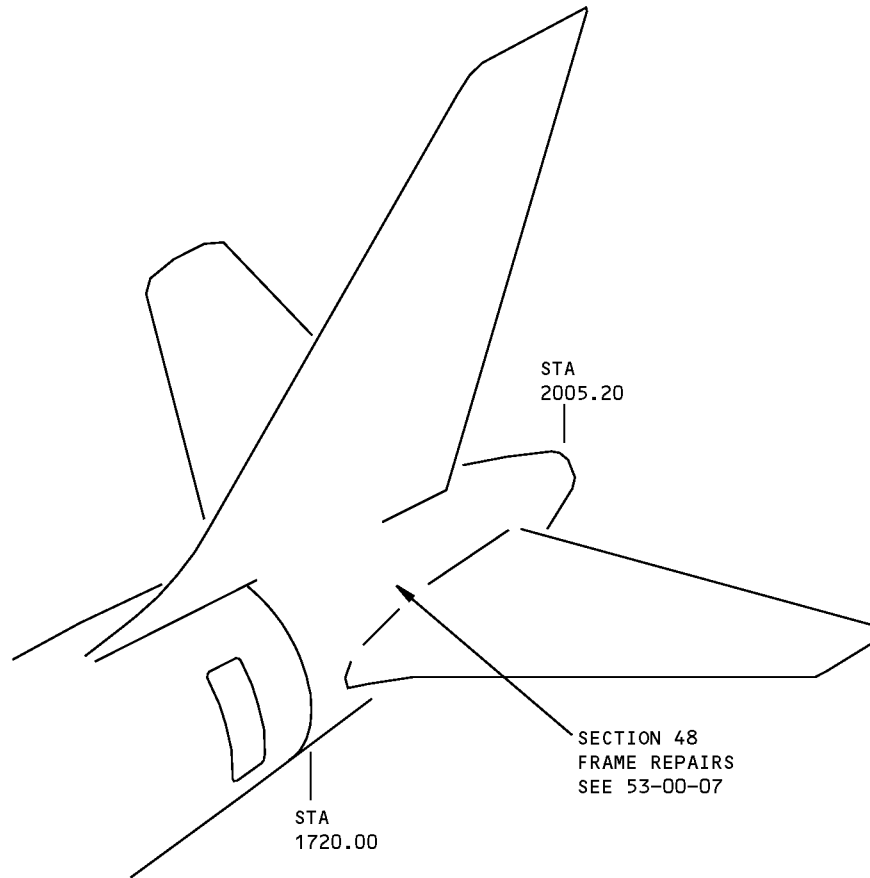
D634N201

ALLOWABLE DAMAGE GENERAL
Page 101
53-80-07
Jan 20/2007



757-200
STRUCTURAL REPAIR MANUAL

REPAIR GENERAL - SECTION 48 - FRAMES



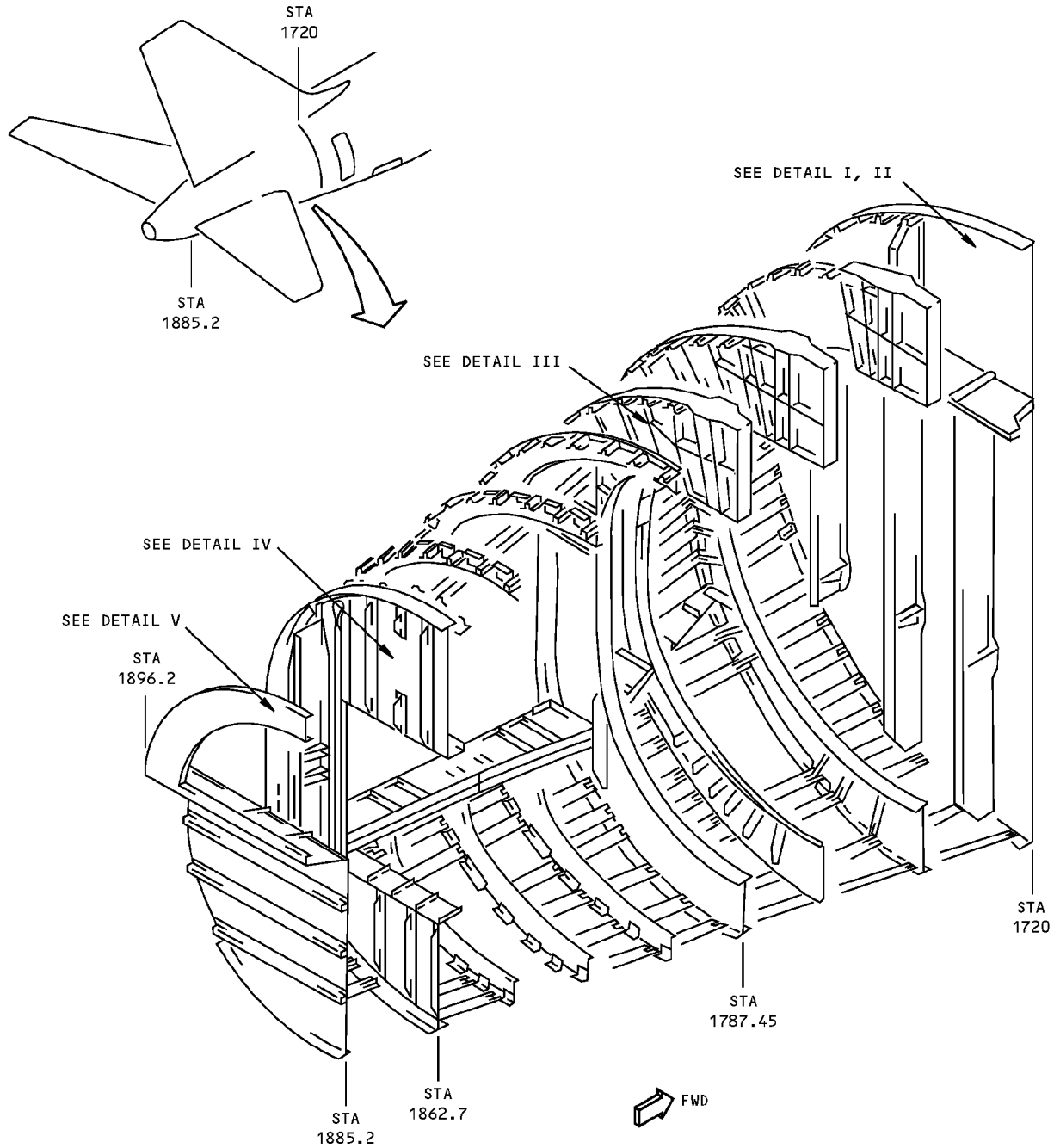
Section 48 Frame Repairs
Figure 201

D634N201

REPAIR GENERAL
Page 201
53-80-07
Jan 20/2005

**757-200
STRUCTURAL REPAIR MANUAL**

IDENTIFICATION 1 - SECTION 48 - BULKHEADS



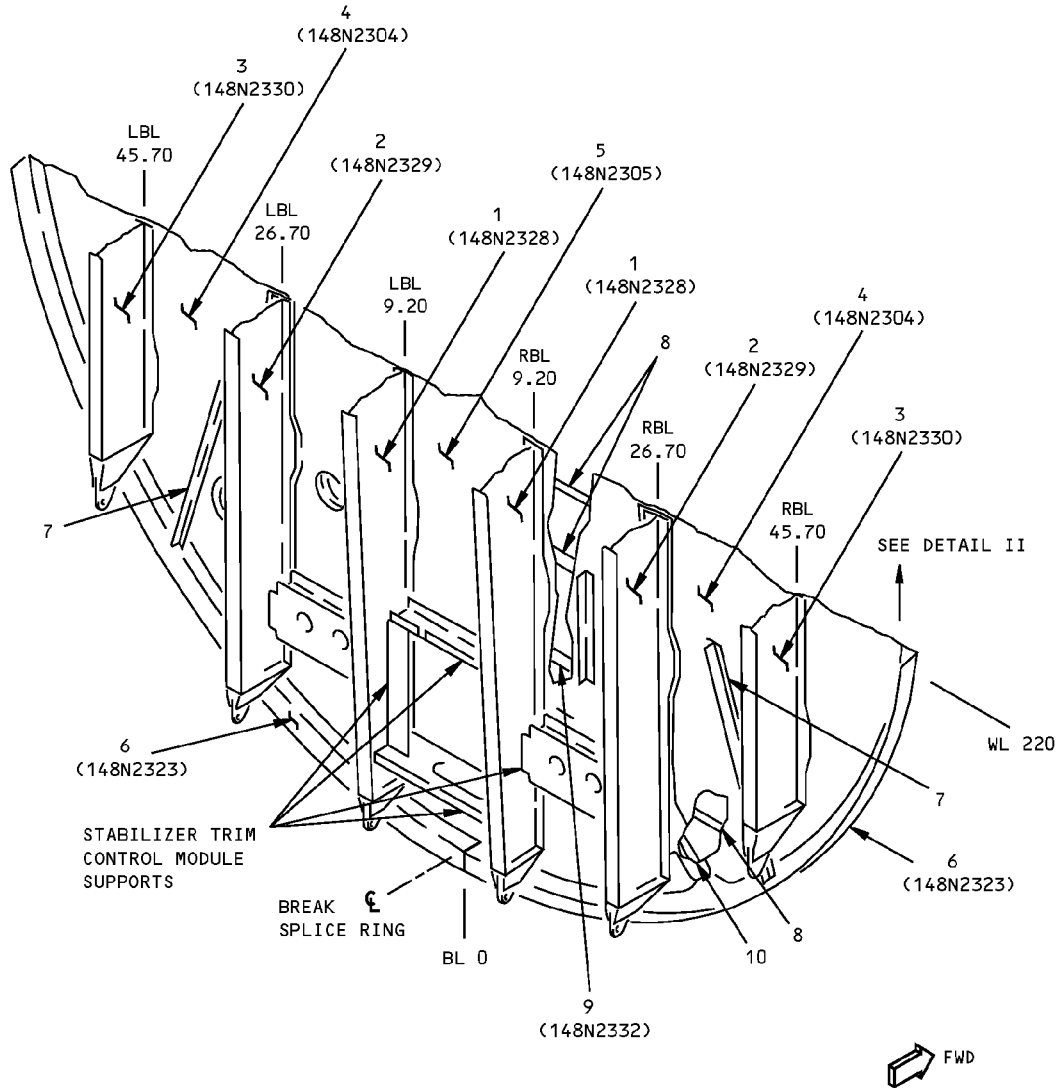
NOTES

- | | |
|--|--|
| <p>A FOR CUM LINE NUMBERS:
1 THRU 14</p> <p>B FOR ALL AIRPLANES EXCEPT THOSE LISTED IN A</p> <p>C FOR AIRLINES WITH CUM LINE NUMBERS:
301 AND ON</p> | <p>D FOR CUM LINE NUMBERS:
1 THRU 554</p> <p>E FOR AIRLINES 556 AND ON</p> |
|--|--|

**Section 48 Bulkhead Identification
Figure 1 (Sheet 1 of 11)**

**757-200
STRUCTURAL REPAIR MANUAL**

REF DWG
148N2301



AFT PRESSURE BULKHEAD STA 1720
DETAIL I

LIST OF
MATERIAL

**Section 48 Bulkhead Identification
Figure 1 (Sheet 2 of 11)**

IDENTIFICATION 1
Page 2
Jan 20/2005

53-80-08

D634N201



**757-200
STRUCTURAL REPAIR MANUAL**

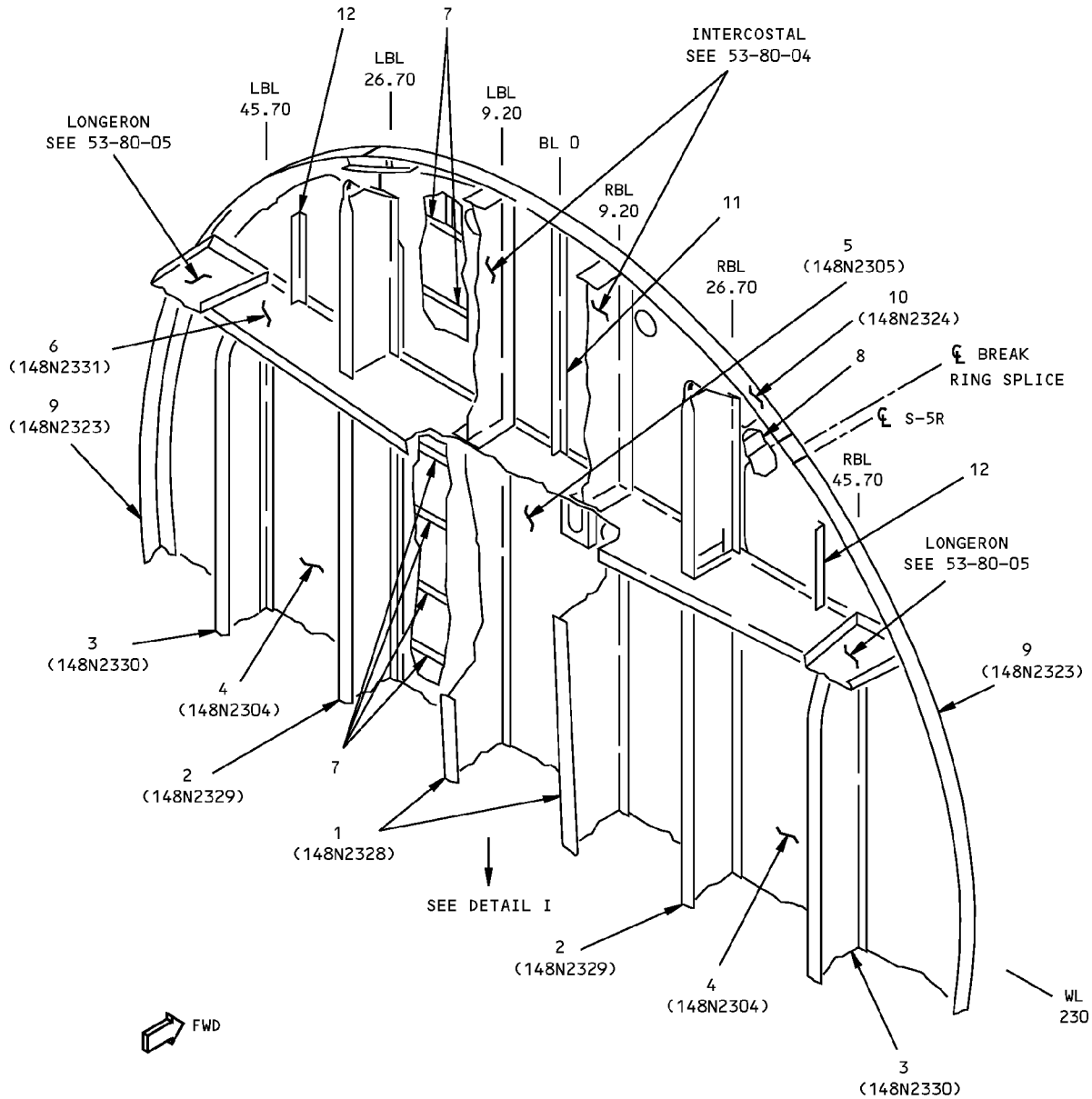
ITEM	DESCRIPTION	GAGE	MATERIAL	EFFECTIVITY	
1	BEAM FWD CHORD	0.071	BAC1503-100003 2024-T3511 (2 BACK-TO-BACK ANGLES)		
	WEB AFT CHORD		2024-T3 BAC1514-1096 2024-T3511 (2 BACK-TO-BACK ANGLES)		
2	BEAM FWD CHORD	0.071	BAC1503-100003 2024-T3511 (2 BACK-TO-BACK ANGLES)		
	WEB AFT CHORD		2024-T3 BAC1503-100282 2024-T3511 (2 BACK-TO-BACK ANGLES)		
3	BEAM FWD CHORD	0.071	BAC1503-100003 2024-T3511 (2 BACK-TO-BACK ANGLES)		
	WEB AFT CHORD		2024-T3 BAC1503-100282 2024-T42 (2 BACK-TO-BACK ANGLES)		
4	WEB	0.112	2024-T3 CHEM MILLED		
5	WEB	0.250	2024-T351 CHEM MILLED		
6	LWR BREAK RING		BAC1514-1742 7075-T6511 BAC1514-2822 7075-T73		C
7	STIFFENER		AND10136-2401 2024-T3511		
8	STIFFENER		AND10140-1204 2024-T3511		
9	FAIL-SAFE BEAM FWD CHORD	0.071	BAC1503-100282 7075-T6		
	WEB		7075-T6		
	AFT CHORD		BAC1505-100832 2024-T3511		
10	STIFFENER		AND10136-3001 2024-T3511		

LIST OF MATERIALS FOR DETAIL I

**Section 48 Bulkhead Identification
Figure 1 (Sheet 3 of 11)**

**757-200
STRUCTURAL REPAIR MANUAL**

REF DWG
148N2301



**AFT PRESSURE BULKHEAD
STA 1720
DETAIL II**

**Section 48 Bulkhead Identification
Figure 1 (Sheet 4 of 11)**

LIST OF MATL

IDENTIFICATION 1
Page 4
Jan 20/2005

53-80-08

D634N201



**757-200
STRUCTURAL REPAIR MANUAL**

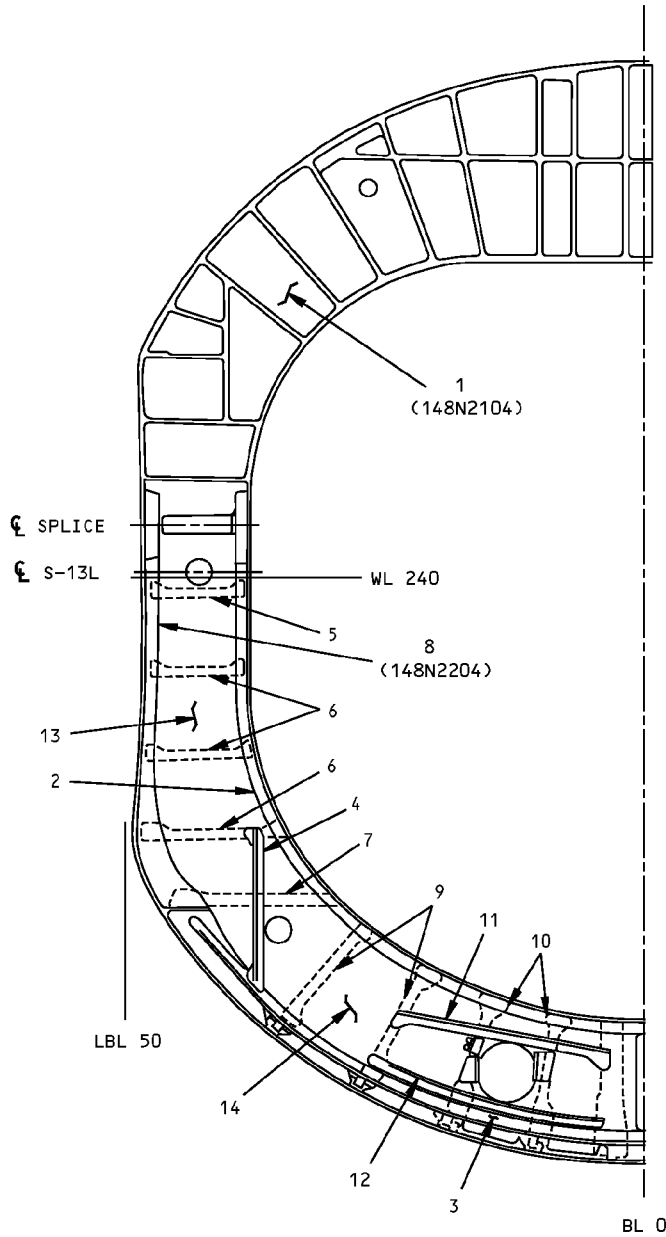
ITEM	DESCRIPTION	GAGE	MATERIAL	EFFECTIVITY
1	BEAM FWD CHORD	0.071	BAC1503-100003 2024-T3511 (2 BACK-TO-BACK ANGLES)	
	WEB AFT CHORD		2024-T3 BAC1514-1096 2024-T3511 (2 BACK-TO-BACK ANGLES)	
2	BEAM FWD CHORD	0.071	BAC1503-100003 2024-T3511 (2 BACK-TO-BACK ANGLES)	
	WEB AFT CHORD		2024-T3 BAC1503-100282 2024-T3511 (2 BACK-TO-BACK ANGLES)	
3	BEAM FWD CHORD	0.071	BAC1503-100003 2024-T3511 (2 BACK-TO-BACK ANGLES)	
	WEB AFT CHORD		2024-T3 BAC1503-100282 2024-T42 (2 BACK-TO-BACK ANGLES)	
4	WEB	0.112	2024-T3 CHEM MILLED	
5	WEB	0.250	2024-T351 CHEM MILLED	
6	BEAM AFT CAP	0.09	BAC1514-1096 2024-T3511 (2 NESTING ANGLES)	
	WEB FWD CAP		2024-T3 BAC1503-100003 2024-T3511 (2 BACK-TO-BACK ANGLES)	
7	STIFFENER		AND10140-1204 2024-T3511	
8	STIFFENER		AND10136-3001 2024-T3511	
9	LWR BREAK RING		BAC1514-1742 7075-T6511	
10	UPR BREAK RING		BAC1514-2656 7075-T651	
11	STIFFENER		AND10136-2408 7075-T73511	
12	STIFFENER		AND10136-2002 2024-T3511	

LIST OF MATERIALS FOR DETAIL II

**Section 48 Bulkhead Identification
Figure 1 (Sheet 5 of 11)**

**757-200
STRUCTURAL REPAIR MANUAL**

REF DWGS:
148N2201
148N2101



STA 1787.45

REAR VIEW
STA 1787.45 BULKHEAD
DETAIL III



**Section 48 Bulkhead Identification
Figure 1 (Sheet 6 of 11)**

IDENTIFICATION 1
Page 6
Jan 20/2005

53-80-08

D634N201



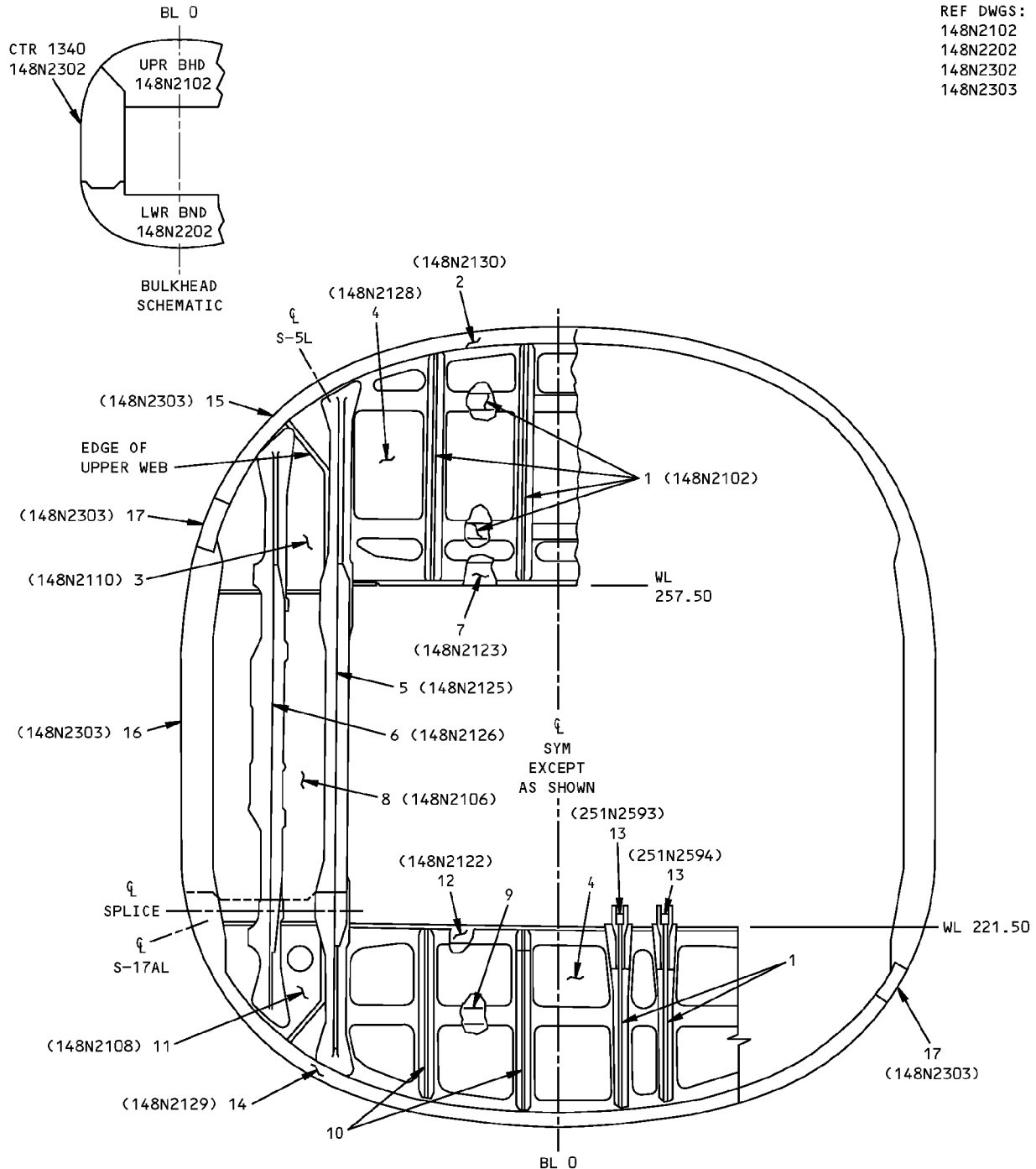
**757-200
STRUCTURAL REPAIR MANUAL**

ITEM	DESCRIPTION	GAGE	MATERIAL	EFFECTIVITY		
1	UPR BULKHEAD		FORGING 7175-T736			
2	INNER CHORD		AND10136-2408 7075-T73			
3	OUTER CHORD		BAC1514-666 7075-T73			
4	VERTICAL TIE		AND10136-2405 7075-T62			
5	STIFFENER		AND10136-2004 7075-T6511			
6	STIFFENER		AND10136-2001 7075-T6511			
7	SHEAR TIE		BAC1505-100172 7075-T6511			
8	OUTER CHORD	2.75	7075-T7351			
9	STIFFENER		AND10136-2401 7075-T6511			
10	STIFFENER		AND10136-2402 7075-T6511			
11	STIFFENER (LEFT SIDE OUT)		BAC1503-100398 7075-T6511			
12	ANGLE (LEFT SIDE OUT)		AND10133-1003 7075-T62			
13	WEB	0.100	7075-T6			
14	WEB					
	RIGHT SIDE	0.08	7075-T6 CHEM-MILLED	<table border="1"> <tr><td>A</td></tr> <tr><td>B</td></tr> </table>	A	B
A						
B						
	RIGHT SIDE	0.100	7075-T6 CHEM-MILLED			
	LEFT SIDE	0.100	7075-T6 CHEM-MILLED			

**Section 48 Bulkhead Identification
Figure 1 (Sheet 7 of 11)**

**757-200
STRUCTURAL REPAIR MANUAL**

REF DWGS:
148N2102
148N2202
148N2302
148N2303



**REAR VIEW
STA 1862.7 BULKHEAD
DETAIL IV**

**Section 48 Bulkhead Identification
Figure 1 (Sheet 8 of 11)**

LIST OF MATL

IDENTIFICATION 1
Page 8
Jan 20/2005

53-80-08

D634N201



**757-200
STRUCTURAL REPAIR MANUAL**

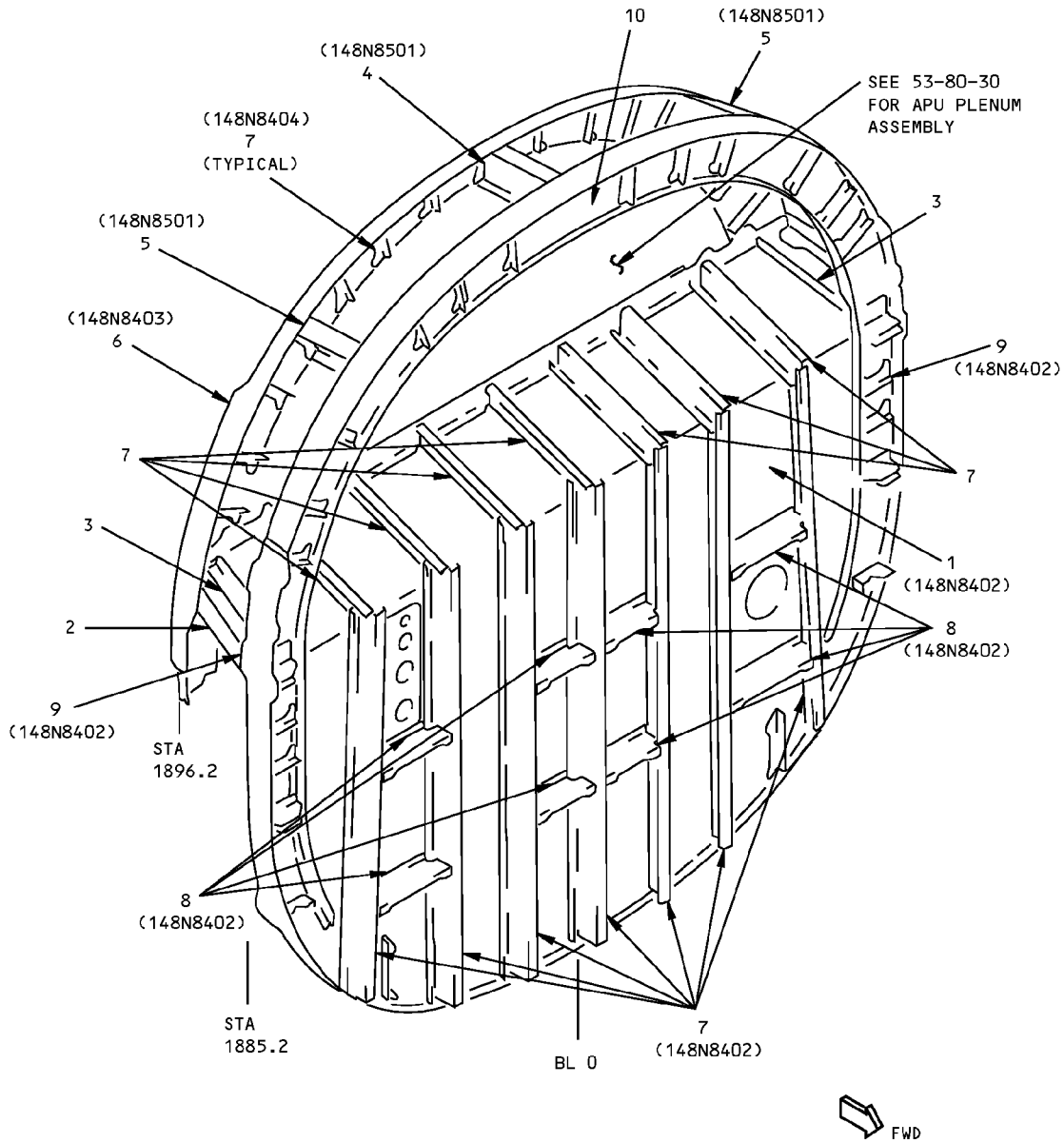
ITEM	DESCRIPTION	GAGE	MATERIAL	EFFECTIVITY
1	STIFFENER		AND10136-3002 7075-T6511	
2	UPR CHORD		BAC1514-2657 7075-T73	
3	UPR FITTING	4.50	FORGING 7075-T73	
4	WEB	0.100	2024-T3	
5	BEAM		BAC1506-3369 7075-T6511	
6	BEAM		BAC1506-3370 7075-T6511	
7	CHORD		BAC1514-1847 7075-T6511	
8	CENTER FITTING	4.50	FORGING 7075-T73	
9	STIFFENER		AND10136-3001 7075-T6511	
10	STIFFENER		AND10136-2003 7075-T6511	
11	LWR FITTING	4.75	FORGING 7075-T73	
12	CHORD		BAC1514-1847 7075-T6511	
13	FITTING	2.00	FORGED BLOCK 7075-T73	
14	LWR CHORD		BAC1514-2657 7075-T73	
15	RIGHT BREAK RING		BAC1503-100688 BAC1503-100931	D E
16	LEFT BREAK RING		BAC1503-100688 BAC1503-100931	D E
17	SPLICE PLATE		BAC1503-100688	

LIST OF MATERIALS FOR DETAIL IV

**Section 48 Bulkhead Identification
Figure 1 (Sheet 9 of 11)**

**757-200
STRUCTURAL REPAIR MANUAL**

REF DWG
148N8401



**FIREWALL AND STA 1885.2 BULKHEAD
FRONT VIEW
DETAIL V**

LIST OF
MATERIAL

**Section 48 Bulkhead Identification
Figure 1 (Sheet 10 of 11)**

IDENTIFICATION 1
Page 10
Jan 20/2005

53-80-08

D634N201



**757-200
STRUCTURAL REPAIR MANUAL**

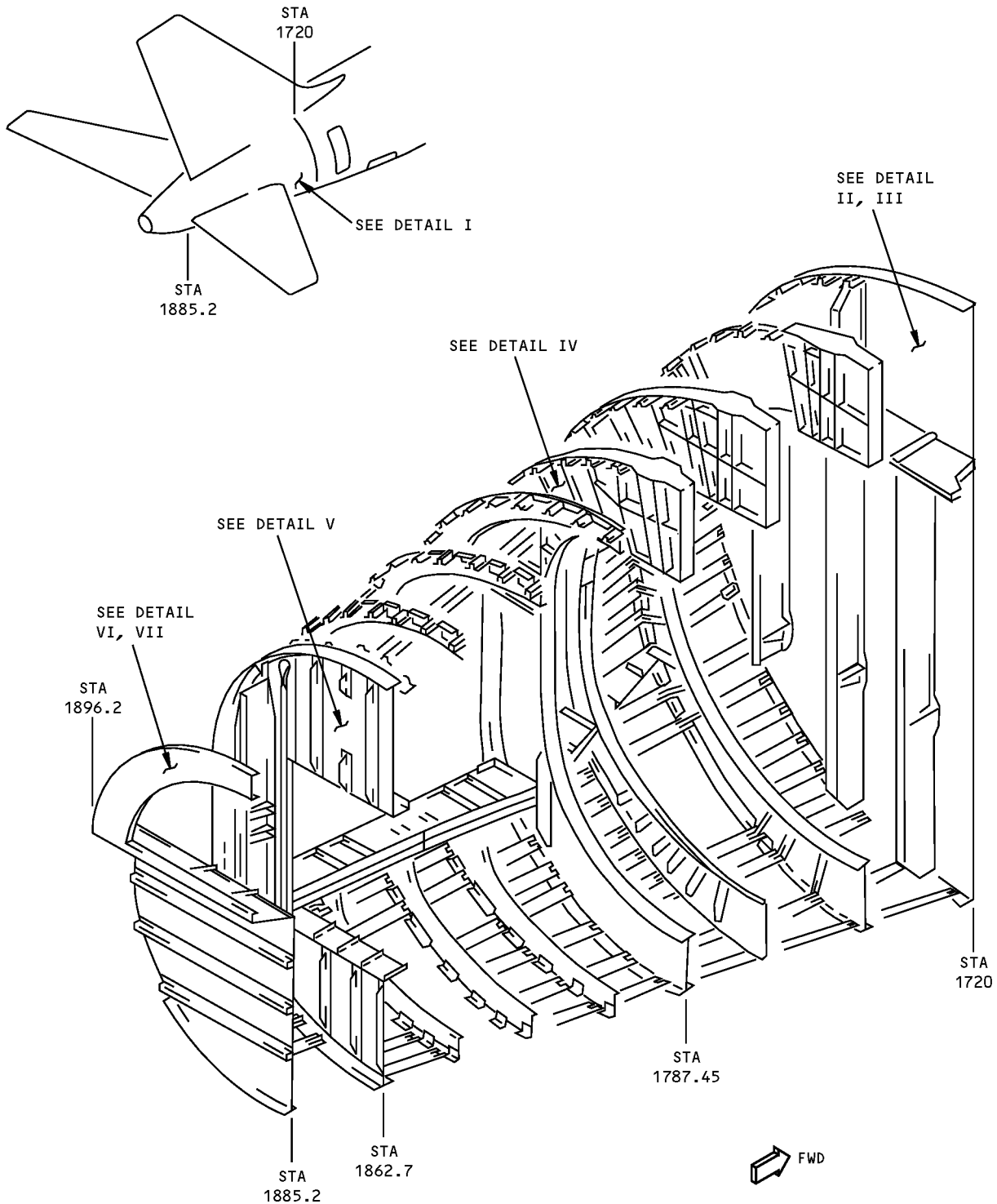
ITEM	DESCRIPTION	GAGE	MATERIAL	EFFECTIVITY
1	WEB	0,016	TI-6AL-4V	
2	STRAP	0.063	TI-6AL-4V	
3	STIFFENER	0.063	TI-6AL-4V	
4	INTERCOSTAL			
	UPR CHORD		BAC1505-100166 7075-T6511	
	WEB	0.04	2024-T3	
	LWR CHORD		BAC1505-100166 7075-T6511	
	END CHORD	0.08	TI-6AL-4V	
	END CHORD		AND10136-2401 7075-T6511	
5	INTERCOSTAL			
	UPR CHORD		BAC1505-100166 7075-T6511	
	WEB	0.05	2024-T3	
	LWR CHORD		BAC1505-100166 7075-T6511	
	END CHORD	0.08	TI-6AL-4V	
	END CHORD		AND10136-2401 7075-T6511	
6	FRAME			
	FWD CHORD	0.063	TI-6AL-4V	
	AFT CHORD	0.05	TI-6AL-4V	
	WEB	0.02	TI-6AL-4V	
7	STIFFENER	0.05	TI-6AL-4V	
8	INTERCOSTAL	0.05	TI-6AL-4V	
9	LOWER FRAME			
	INNER CHORD	0.063	TI-6AL-4V	
	WEB	0.016	TI-6AL-4V	
	OUTER CHORD	0.063	TI-6AL-4V	
10	UPPER FRAME			
	INNER CHORD		BAC1505-100261 7075-T6	
	WEB	0.04	7075-T6	
	OUTER CHORD		BAC1505-100081 7075-T6	

LIST OF MATERIALS FOR DETAIL V

**Section 48 Bulkhead Identification
Figure 1 (Sheet 11 of 11)**

**757-200
STRUCTURAL REPAIR MANUAL**

ALLOWABLE DAMAGE 1 - SECTION 48 - BULKHEADS

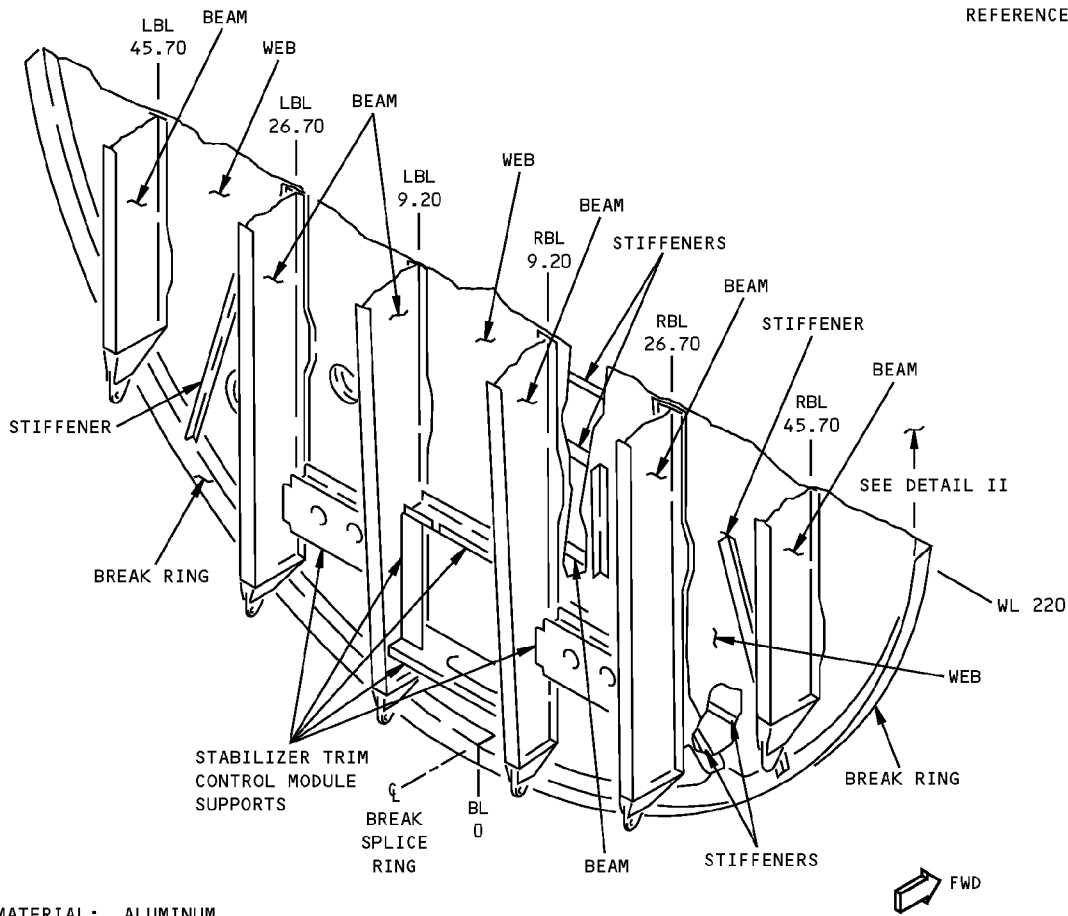


DETAIL I

Section 48 Bulkhead Allowable Damage
Figure 101 (Sheet 1 of 11)

**757-200
STRUCTURAL REPAIR MANUAL**

REFERENCE DRAWING
148N2301



MATERIAL: ALUMINUM

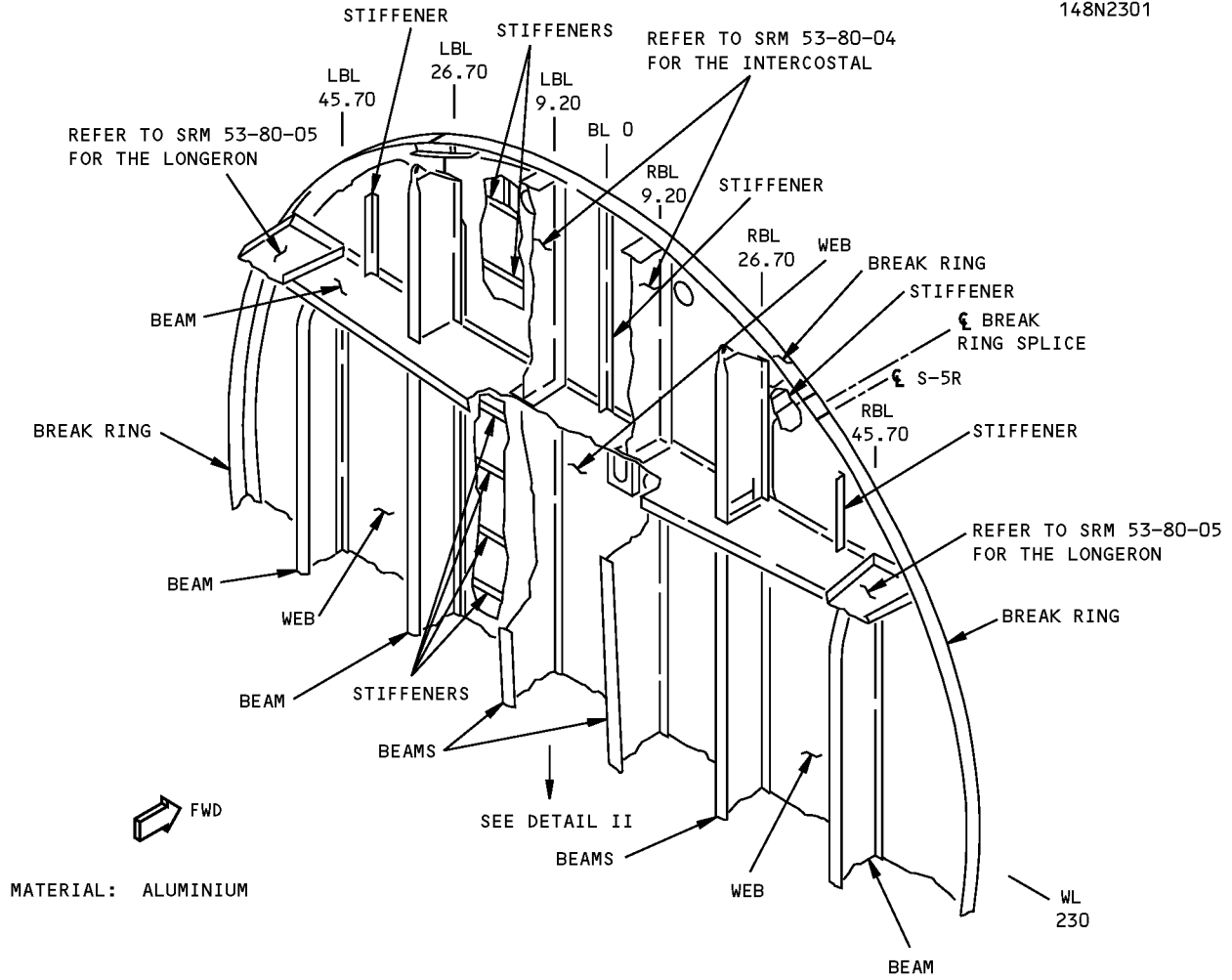
**AFT PRESSURE BULKHEAD STA 1720
DETAIL II**

DESCRIPTION	CRACKS	NICKS, GOUGES AND CORROSION	DENTS	HOLES AND PUNCTURES
BREAK RING	G	D	NOT ALLOWED	NOT ALLOWED
WEB	C	NOT ALLOWED	NOT ALLOWED	NOT ALLOWED
STIFFENERS	A	F	NOT ALLOWED	NOT ALLOWED
BEAMS CHORDS WEBS FITTINGS	A H K	F F B	NOT ALLOWED SEE DETAIL IX NOT ALLOWED	NOT ALLOWED E NOT ALLOWED

**Section 48 Bulkhead Allowable Damage
Figure 101 (Sheet 2 of 11)**

**757-200
STRUCTURAL REPAIR MANUAL**

REFERENCE DRAWING
148N2301



**AFT PRESSURE BULKHEAD
STA 1720
DETAIL III**

DESCRIPTION	CRACKS	NICKS, GOUGES AND CORROSION	DENTS	HOLES AND PUNCTURES
BEAMS				
CHORDS	A	F	NOT PERMITTED	NOT PERMITTED
WEBS	H	F	SEE DETAIL X	E
FITTINGS	K	B	NOT PERMITTED	NOT PERMITTED
WEBS	C	NOT PERMITTED	NOT PERMITTED	NOT PERMITTED
STIFFENERS	A	F	NOT PERMITTED	NOT PERMITTED
BREAK RING	G	D	NOT PERMITTED	NOT PERMITTED

**Section 48 Bulkhead Allowable Damage
Figure 101 (Sheet 3 of 11)**

ALLOWABLE DAMAGE 1

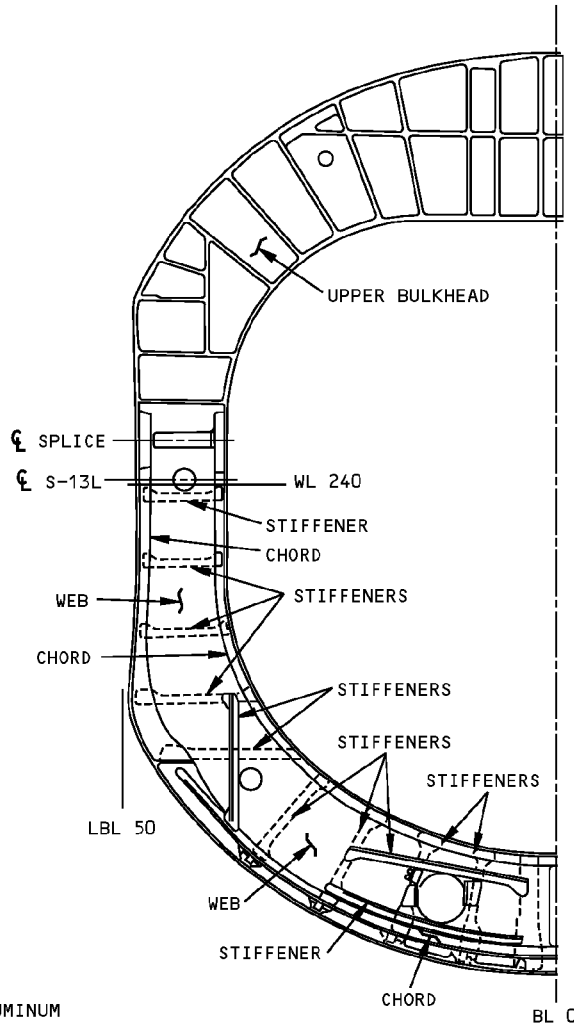
53-80-08

Page 103
Jan 20/2005

D634N201

**757-200
STRUCTURAL REPAIR MANUAL**

REFERENCE DRAWINGS
148N2201
148N2101



MATERIAL: ALUMINUM

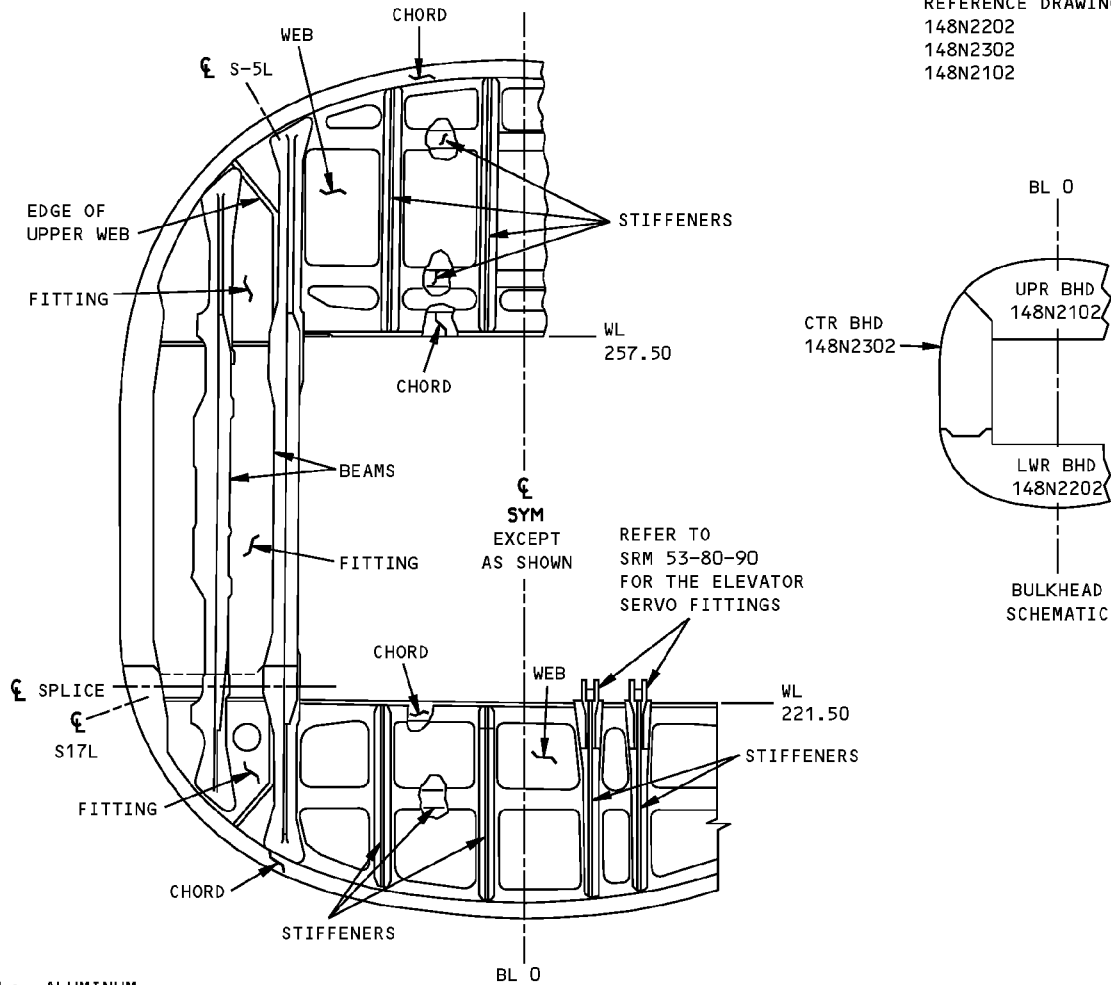
REAR VIEW
STA 1787.45 BULKHEAD
DETAIL IV

DESCRIPTION	CRACKS	NICKS, GOUGES AND CORROSION	DENTS	HOLES AND PUNCTURES
UPPER BULKHEAD	C	D	NOT PERMITTED	NOT PERMITTED
CHORDS	G	D	NOT PERMITTED	NOT PERMITTED
STIFFENERS	A	F	NOT PERMITTED	NOT PERMITTED
WEB	H	F	SEE DETAIL X	E

**Section 48 Bulkhead Allowable Damage
Figure 101 (Sheet 4 of 11)**

**757-200
STRUCTURAL REPAIR MANUAL**

REFERENCE DRAWINGS
148N2202
148N2302
148N2102



MATERIAL: ALUMINUM

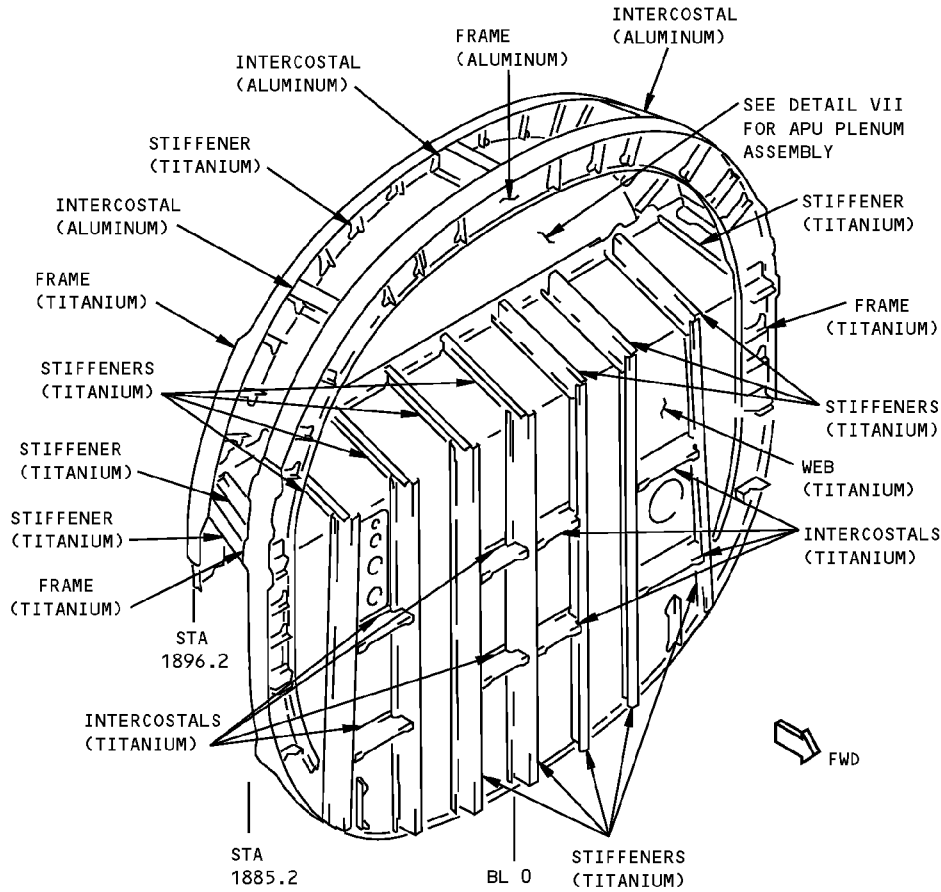
**REAR VIEW
STA 1862.7 BULKHEAD
DETAIL V**

DESCRIPTION	CRACKS	NICKS, GOUGES AND CORROSION	DENTS	HOLES AND PUNCTURES
STIFFENERS	A	F	NOT PERMITTED	NOT PERMITTED
CHORDS	G	D	NOT PERMITTED	NOT PERMITTED
BEAMS CHORDS WEBS	G C	D D	NOT PERMITTED SEE DETAIL X	NOT PERMITTED E
WEB	C	D	SEE DETAIL X	E
FITTINGS	K	I	NOT PERMITTED	NOT PERMITTED

**Section 48 Bulkhead Allowable Damage
Figure 101 (Sheet 5 of 11)**

**757-200
STRUCTURAL REPAIR MANUAL**

REFERENCE DRAWING
148N8401



**FIREWALL AND STA 1885.2 BULKHEAD
FRONT VIEW
DETAIL VI**

DESCRIPTION	CRACKS	NICKS, GOUGES AND CORROSION	DENTS	HOLES AND PUNCTURES
FRAMES CHORDS WEBS	A H	F F	NOT PERMITTED SEE DETAIL X	NOT PERMITTED NOT PERMITTED
INTERCOSTALS CHORDS WEBS	A H	F F	NOT PERMITTED SEE DETAIL X	NOT PERMITTED NOT PERMITTED
STIFFENERS	A	F	NOT PERMITTED	NOT PERMITTED
WEBS	H	F	SEE DETAIL X	J

**Section 48 Bulkhead Allowable Damage
Figure 101 (Sheet 6 of 11)**

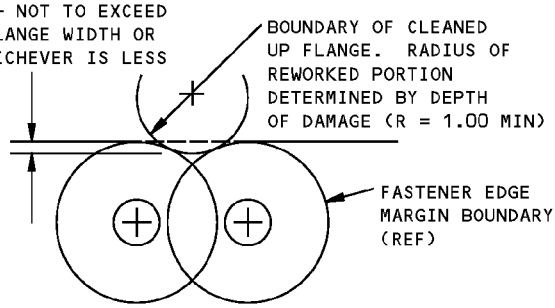
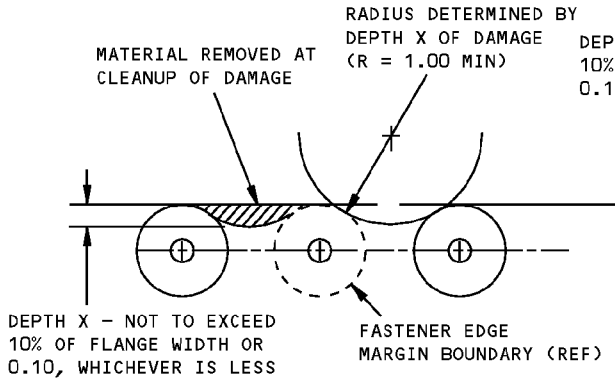
STRUCTURAL REPAIR MANUAL

NOTES

- REFINISH REWORKED AREAS AS GIVEN IN AMM 51-20.
- A** CRACKS NOT PERMITTED EXCEPT FOR EDGE CRACKS WHICH MUST BE REMOVED AS SHOWN IN DETAILS VIII AND XII.
- B** FOR EDGE DAMAGE SEE DETAIL XIV. FOR LUG DAMAGE SEE DETAIL XIII. FOR OTHER DAMAGE SEE DETAIL IX. DAMAGE NOT PERMITTED IN VICINITY OF BUSHINGS
- C** CRACKS NOT PERMITTED EXCEPT FOR EDGE CRACKS WHICH MUST BE REMOVED AS SHOWN IN DETAILS VIII AND XI. REFER TO **L** FOR SHOT PEEN REQUIREMENTS.
- D** REMOVE DAMAGE AS SHOWN IN DETAILS VIII AND IX. REFER TO **L** FOR SHOT PEEN REQUIREMENTS.
- E** CLEAN OUT DAMAGE UP TO 0.25 MAX DIA AND NOT CLOSER THAN 1.0 INCH TO FASTENER HOLE. FILL HOLE WITH A 2117-T3 OR T4 ALUMINUM RIVET INSTALLED WET WITH BMS5-95 SEALANT. ALL OTHER HOLES TO BE REPAIRED
- F** REMOVE DAMAGE AS SHOWN IN DETAILS VIII AND IX.
- G** CRACKS NOT PERMITTED EXCEPT FOR EDGE CRACKS WHICH MUST BE REMOVED AS SHOWN IN DETAILS VIII AND XI. REFER TO **L** FOR SHOT PEEN REQUIREMENTS.
- H** CRACKS NOT PERMITTED EXCEPT FOR EDGE CRACKS WHICH MUST BE REMOVED AS SHOWN DETAILS VIII AND XI.
- I** FOR EDGE DAMAGE SEE DETAIL XIV. FOR LUG DAMAGE SEE DETAIL XIII. FOR OTHER DAMAGE SEE DETAIL IX. DAMAGE NOT PERMITTED IN VICINITY OF BUSHINGS. REFER TO **L** FOR SHOT PEEN REQUIREMENTS
- J** CLEAN OUT DAMAGE UP TO 0.25 MAX DIA AND NOT CLOSER THAN 1.0 INCH TO FASTENER HOLE. FILL HOLE WITH A MONEL RIVET INSTALLED DRY. ALL OTHER HOLES TO BE REPAIRED.
- K** CRACKS NOT PERMITTED EXCEPT FOR EDGE CRACKS WHICH MUST BE REMOVED AS SHOWN IN DETAIL XIV. REFER TO **L** FOR SHOT PEEN REQUIREMENTS.
- L** SHOT PEEN REWORKED AREA AS GIVEN IN CMM 20-10-03. REFER TO SRM 51-20-06 FOR SHOT PEEN REQUIREMENTS.

Section 48 Bulkhead Allowable Damage
Figure 101 (Sheet 8 of 11)

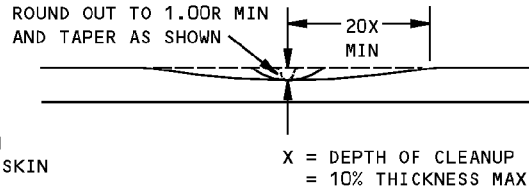
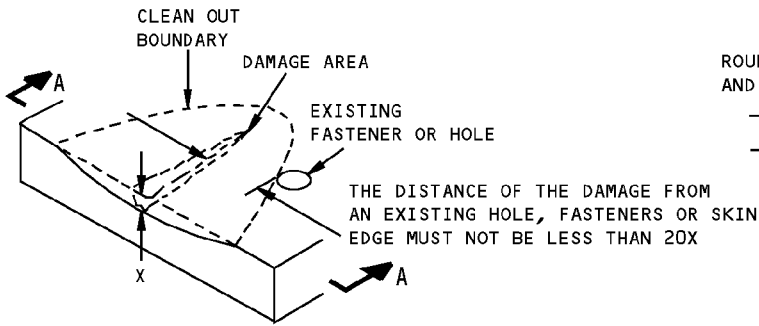
STRUCTURAL REPAIR MANUAL



DAMAGE CLEANUP OF EDGES WHERE FASTENER EDGE MARGINS DO NOT OVERLAP

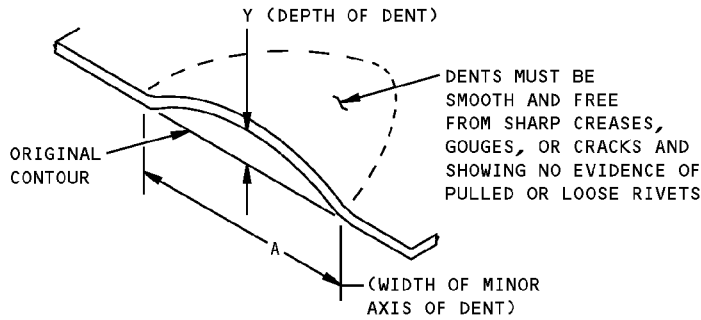
DAMAGE CLEANUP OF EDGES WHERE FASTENER EDGE MARGINS OVERLAP

DETAIL VIII



SECTION A-A

**REMOVAL OF NICK, GOUGE AND SCRATCH DAMAGE ON A SURFACE
DETAIL IX**



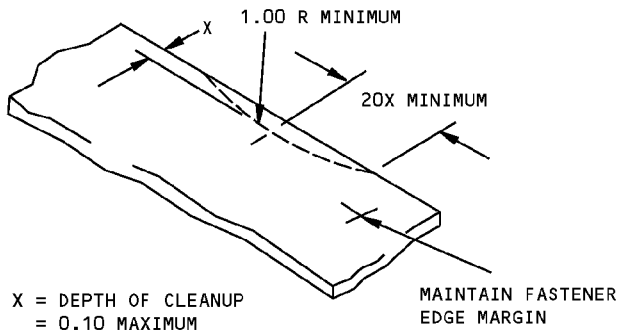
$\frac{A}{Y}$ MUST NOT BE LESS THAN 30

Y MAX = 0.05 OR WEB THICKNESS, WHICHEVER IS LESS

**ALLOWABLE DAMAGE FOR DENT
DETAIL X**

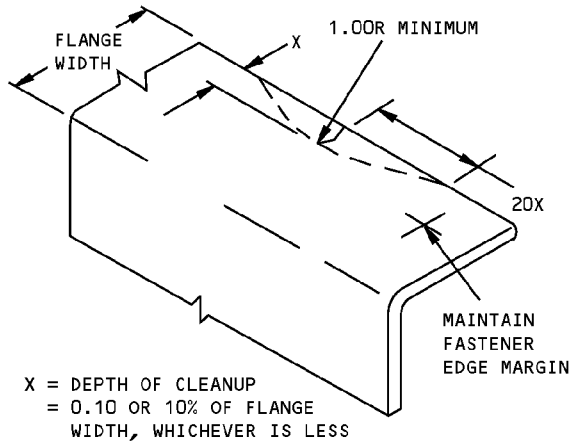
**Section 48 Bulkhead Allowable Damage
Figure 101 (Sheet 9 of 11)**

STRUCTURAL REPAIR MANUAL



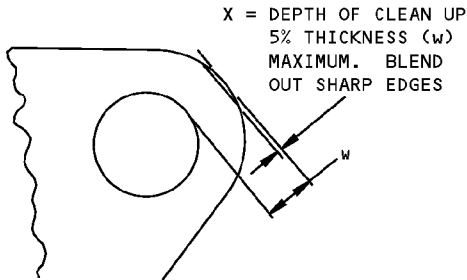
**REMOVAL OF NICK OR CRACK
DAMAGE ON AN EDGE**

DETAIL XI



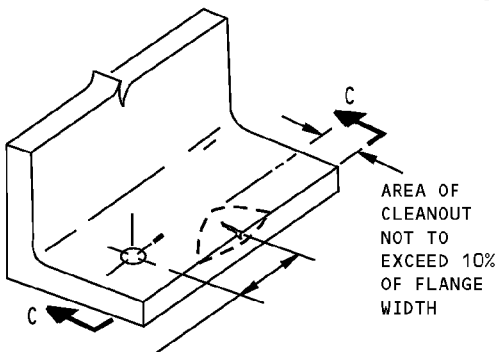
**REMOVAL OF NICK OR CRACK
DAMAGE ON AN EDGE**

DETAIL XII



DAMAGE CLEAN UP FOR EDGES OF LUG

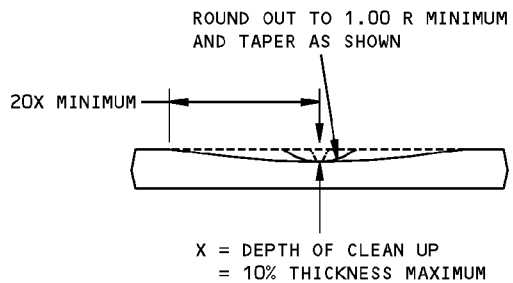
DETAIL XIII



THE DISTANCE OF THE DAMAGE FROM AN
EXISTING HOLE, FASTENERS OR EDGE
MUST NOT BE LESS THAN 20X

**REMOVAL OF NICK OR CRACK
DAMAGE ON AN EDGE**

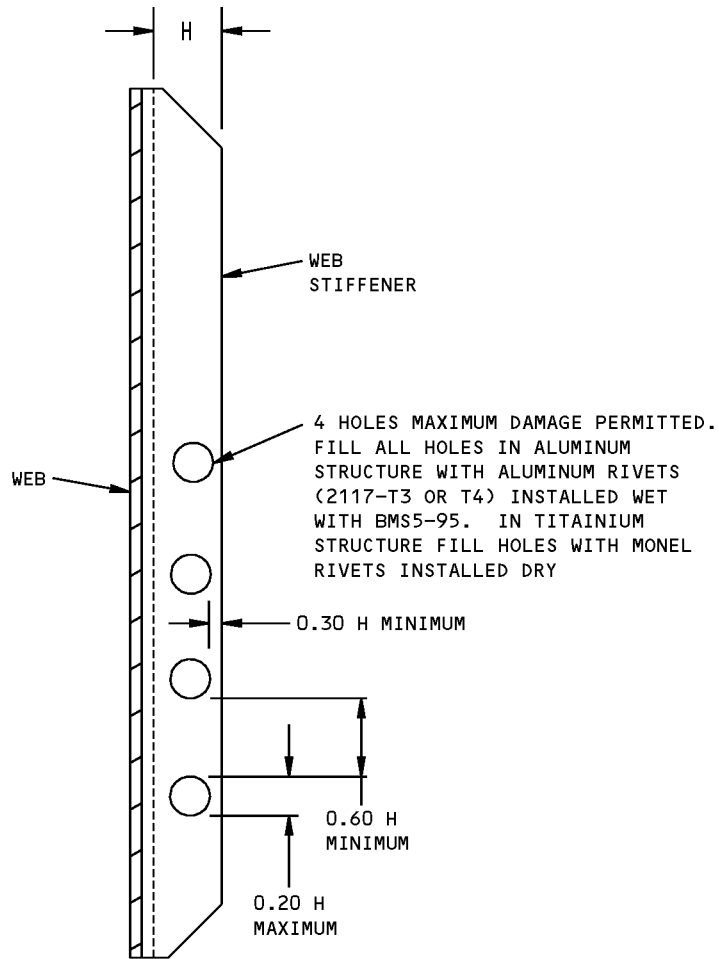
DETAIL XIV



SECTION C-C

**Section 48 Bulkhead Allowable Damage
Figure 101 (Sheet 10 of 11)**

757-200
STRUCTURAL REPAIR MANUAL



NOTE: NO HOLE DAMAGE PERMITTED IN STIFFENER FLANGE FASTENED TO WEB.

ALLOWABLE DAMAGE LIMITS FOR
HOLES IN WEB STIFFENERS

DETAIL XV

Section 48 Bulkhead Allowable Damage
Figure 101 (Sheet 11 of 11)



757-200
STRUCTURAL REPAIR MANUAL

REPAIR GENERAL - SERVICE BULLETIN REPAIR CHART

SERVICE BULLETIN REPAIRS

The following Service Bulletins contain repairs which are available for use where specific damage has been encountered. Usually, the Service Bulletin also covers preventive modification data which operators are encouraged to use to eliminate the need for repair.

DAMAGED AREA	CUM LINE NUMBER EFFECTIVITY	SB NUMBER
APU FIREWALL STIFFENERS	2 THRU 30, 32 THRU 36, 38, 39, AND 41	53-0032

Service Bulletin Repair Chart
Figure 201

STRUCTURAL REPAIR MANUAL

REPAIR 1 - AFT PRESSURE BULKHEAD LOWER WEB AND CHORD REPAIR

REPAIR INSTRUCTIONS

1. Remove any damaged skin, stringers, and stringer end-fittings.
2. Remove the structure attached to the bulkhead web in the repair area as necessary.
3. Cut the web as shown in Detail I and remove the damaged web. Cut the chord as shown in Detail I and remove the damaged chord.
NOTE: To remove and replace the web easily, remove the skin-to-chord fasteners and the chord-to-bulkhead fasteners outboard of the repair area as necessary.
4. Make the repair parts. Refer to Table I.
5. Assemble the repair parts and drill the fastener holes.
6. Disassemble the repair parts.
7. Remove the nicks, scratches, gouges, burrs, and sharp edges from the web, the chord, and the repair parts.
8. Apply alodine to the repair parts and the bare surfaces of the web and chord. Refer to 51-10-01.
9. Apply one layer of BMS 10-11, Type II primer to the repair parts and the bare edges of the web and chord. Refer to 51-21 of the 757 Maintenance Manual.
10. Place the repair web (item 1) into position and install the web splice (item 2) with BMS 5-95 sealant between faying surfaces. Fill the gap between the initial web and the repair web with BMS 5-95 sealant. Make a fillet seat around the edge of the web splice (see Section B-B). Install the bolts wet with BMS 5-95 sealant.
NOTE: The fail-safe beam is moved forward by the web splice. Use fillers (item 10 and 11) as necessary along the fail-safe beam (See Section A-A).
11. Install the forward and aft repair chords (items 3 and 4) and the item 5 chord splice. Apply BMS 5-95 sealant between faying surfaces and in the gap at the chord splice. Install the bolts wet with BMS 5-95 sealant. Install the rivets dry.
12. Install the BL 0 splice straps in the aft repair chord (see Detail I). Replace the damaged stringers and replace or install the necessary stringer end-fittings, except the one at S-26. Install or replace any structure which was removed from the web.
Apply BMS 5-95 sealant between faying surfaces. Apply a fillet seal as shown in Section A-A to the repair chords and also to the initial chords where the fasteners were removed to help remove the damaged web. Install bolts wet with BMS 5-95 sealant. Install rivets dry.
13. Replace the damaged skin with BMS 5-95 sealant between faying surfaces. Apply BMS 5-95 sealant to the skin gap in the repair area and outboard of the repair where skin fasteners were removed to remove the damaged web (see Section A-A). Install bolts wet with BMS 5-95 sealant. Install rivets dry.
14. Install the item 6 chord splice, tapered shims (item 7), fillers (item 8 and item 9), and replace or install a new stringer end fitting at S-26 (item 12). See Sections C-C and D-D. Apply BMS 5-95 sealant between faying surfaces. Install the bolts wet with BMS 5-95 sealant. Install the rivets dry.
15. Paint the repair. Refer to 51-21 of the 757 Maintenance Manual.
16. Apply water displacing corrosion inhibiting compound, BMS 3-23, to all of the exposed structure in the repair area.

**Aft Pressure Bulkhead Lower Web and Chord Repair
Figure 201 (Sheet 1 of 7)**

STRUCTURAL REPAIR MANUAL

NOTES

- THIS REPAIR APPLIES TO LOWER LOBE STRUCTURE DAMAGE BELOW STRINGER S-25.
- WHEN YOU USE THIS REPAIR REFER TO:
 - AMM 51-21 FOR INTERIOR AND EXTERIOR FINISHES.
 - SRM 51-10-01 FOR AERODYNAMIC SMOOTHNESS REQUIREMENTS
 - SRM 51-10-02 FOR INSPECTION AND REMOVAL OF DAMAGE
 - SRM 51-20-01 FOR PROTECTIVE TREATMENT OF METAL
 - SRM 51-20-05 FOR SEALING OF REPAIRS
 - SRM 51-40 FOR FASTENER CODE, INSTALLATION AND REMOVAL, HOLE SIZES, EDGE MARGINS, AND COUNTERSINKING

- [A] APPLY BMS 5-95 SEALANT TO ANY GAPS AS SHOWN.
- [B] INSTALL THE BL O SPLICE STRAPS WHICH WERE REMOVED FOR THE REPAIR. IF THEY ARE DAMAGED, REPLACE THEM.
- [C] FOR BOLTS UNDERNEATH THE CONTROL MODULE BRACKET, PLACE THE HEAD UNDER THE BRACKET WITH THE COLLAR ON THE FORWARD SIDE.
- [D] INSTALL THE BOLT THROUGH THE CONTROL MODULE BRACKET, THE WEB, AND THE SPLICE.
- [E] APPLY A FILLET SEAL ALONG THE EDGE(S) OF THE REPAIR SPLICE (ITEM 2), FORWARD AND AFT AFT REPAIR CHORDS (ITEM 3 AND 4), AND TO THE INITIAL CHORDS WHERE THE FASTENERS WERE REMOVED TO HELP REMOVE THE DAMAGED WEB.
- [F] THE UPPER FACE OF THE TAPERED SHIM (ITEM 7) SHOULD BE PARALLEL TO THE SKIN TO ALLOW THE BOLT TO SEAT PROPERLY.
- [G] THE CONTROL MODULE BRACKET IS INSTALLED ON EARLIER PRODUCTION AIRPLANES ONLY.
- [H] THE SPLICE CUT MAY HAVE TO BE ADJUSTED FROM WHAT IS SHOWN BECAUSE OF FASTENER PATTERNS AT THE CUT.
- [I] CORNER RADII IN ALL DAMAGE CUTOUTS SHOULD BE 0.25 INCH (6 mm) OR LARGER.

- [J] THE REPAIR CHORDS MAY BE MADE FROM SPARE CHORDS PURCHASED FROM THE BOEING COMPANY. THE FOLLOWING PART NUMBERS APPLY:
 - FORWARD CHORD - 146N8835-8201
 - AFT CHORDS - 148N2323-7 LEFT SIDE
 - 148N2323-8 RIGHT SIDE

- [K] THE STRINGER END FITTING MAY BE MACHINED FROM A FORGED BLOCK USING THE INITIAL FITTING DIMENSIONS, OR MAY BE PURCHASED FROM THE BOEING COMPANY (PART NO. 146N8849-1). THE FITTING SHOULD BE MADE OR ORDERED WITH NO PILOT HOLES DRILLED.

- [M] THE NUMBER OF TAPERED SHIMS MAY VARY IF THE FASTENER PATTERN PERMITS THE USE OF ONE-PIECE SHIMS.

Aft Pressure Bulkhead Lower Web and Chord Repair
Figure 201 (Sheet 2 of 7)

STRUCTURAL REPAIR MANUAL

SYMBOLS

- ⊖ REFERENCE FASTENER LOCATION.
- + EXISTING FASTENER LOCATION. INSTALL A FASTENER OF THE SAME TYPE AND SIZE AS THE ORIGINAL FASTENER. OVERSIZE AS NECESSARY.
- ⊕ EXISTING FASTENER LOCATION. INSTALL A BACB30MY6K()X HEX DRIVE BOLT (1/64TH OVER-SIZE) WITH A BACC30M COLLAR.
- ⊕ EXISTING FASTENER LOCATION. INSTALL A BACB30MY6K()X HEX DRIVE BOLT (1/64TH OVER-SIZE) WITH A BACC30M COLLAR.
- ⊕ EXISTING FASTENER LOCATION. INSTALL A BACB30MY8K()X HEX DRIVE BOLT (1/64TH OVER-SIZE) WITH A BACC30M COLLAR.
- ⊖ EXISTING FASTENER LOCATION. INSTALL A BACB30US5K() BOLT INTO A 0.312-0.316 INCH HOLE THROUGH THE PART 1 REPAIR WEB, THE PART 3 AND 4 REPAIR CHORDS, AND THE PART 5 AND 6 SPLICES. INSTALL WITH A BACN10HR5CD SELF-LOCKING NUT, A BACW10BP5CD WASHER UNDER THE HEAD, AND A BACW10BP5DP WASHER UNDER THE NUT.
- ⊕ EXISTING FASTENER LOCATION. INSTALL A BACB30NX6K()X HEX DRIVE BOLT (1/64TH OVER-SIZE) WITH A BACC30X COLLAR.
- ⊕ REPAIR FASTENER AT AN ORIGINAL FASTENER LOCATION. INSTALL A BACB30NX6K() HEX DRIVE BOLT WITH A BACC30X COLLAR.
- ⊖ EXISTING FASTENER LOCATION. INSTALL A BACB30US6K() BOLT INTO A 0.375-0.379 INCH HOLE THROUGH THE PART 1 REPAIR WEB AND THE PART 3 AND 4 REPAIR CHORDS. INSTALL THE BOLT WITH A BACN10HR6CD SELF-LOCKING NUT, A BACW10BP6CD WASHER UNDER THE HEAD AND A BACW10BP6DP WASHER UNDER THE NUT.

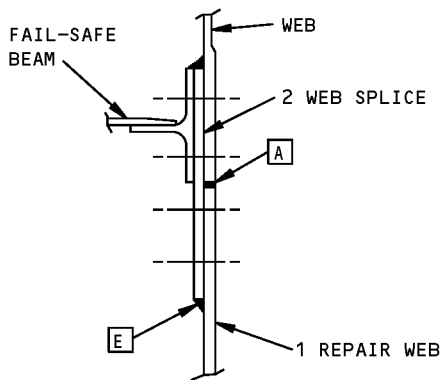
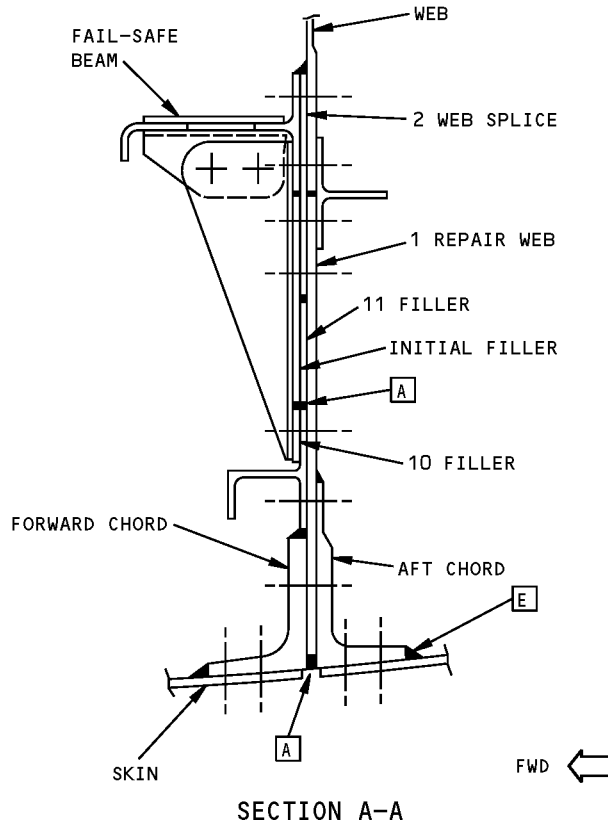
IF BOTH OF THE INITIAL STRINGER END FITTINGS ARE BEING INSTALLED, THEN THEIR INITIAL FASTENER HOLES MAY BE USED. IF AN END FITTING IS BEING REPLACED, DRILL 0.375-0.379 INCH FASTENER HOLES INTO THE NEW END FITTING.

REPAIR MATERIAL			
PART		QTY	MATERIAL
1	REPAIR WEB	1	0.112 2024-T3
2	WEB SPLICE	1	0.125 2024-T3
3	FORWARD REPAIR CHORD	1	BAC1514-1477 [J] 7075-0, HT TR -T73
4	AFT REPAIR CHORD	2	MACHINE FROM BAC1514-2822 [J] 7075-0, HT TR -T73
5	CHORD SPLICE	4	0.20 7075-T6
6	CHORD SPLICE	4	0.14 7075-T6
7	TAPERED SHIM	AS REQ'D [M]	7075-T6
8	FILLER	2	SAME MATERIAL AS ITEM 9 AND SAME GAGE OR ONE GAGE THICKER
9	FILLER	2	CLAD 7075-T6, GAGE AS REQUIRED
10	FILLER	2	0.125 CLAD 2024-T3
11	FILLER	2	0.125 CLAD 2024-T3
12	STRINGER END FITTING	2	1.75 THICK 7075-T73 FORGED BLOCK [K]

TABLE I

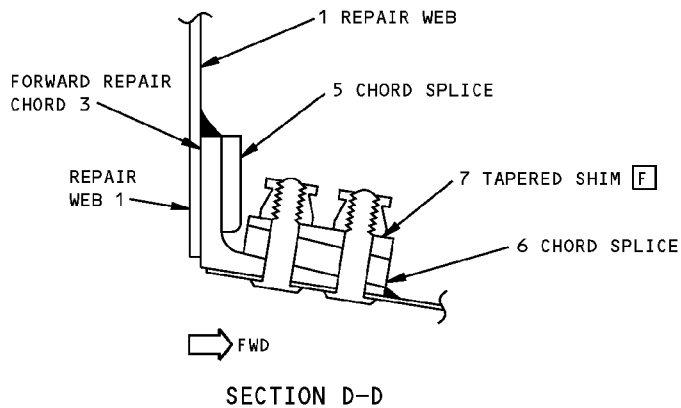
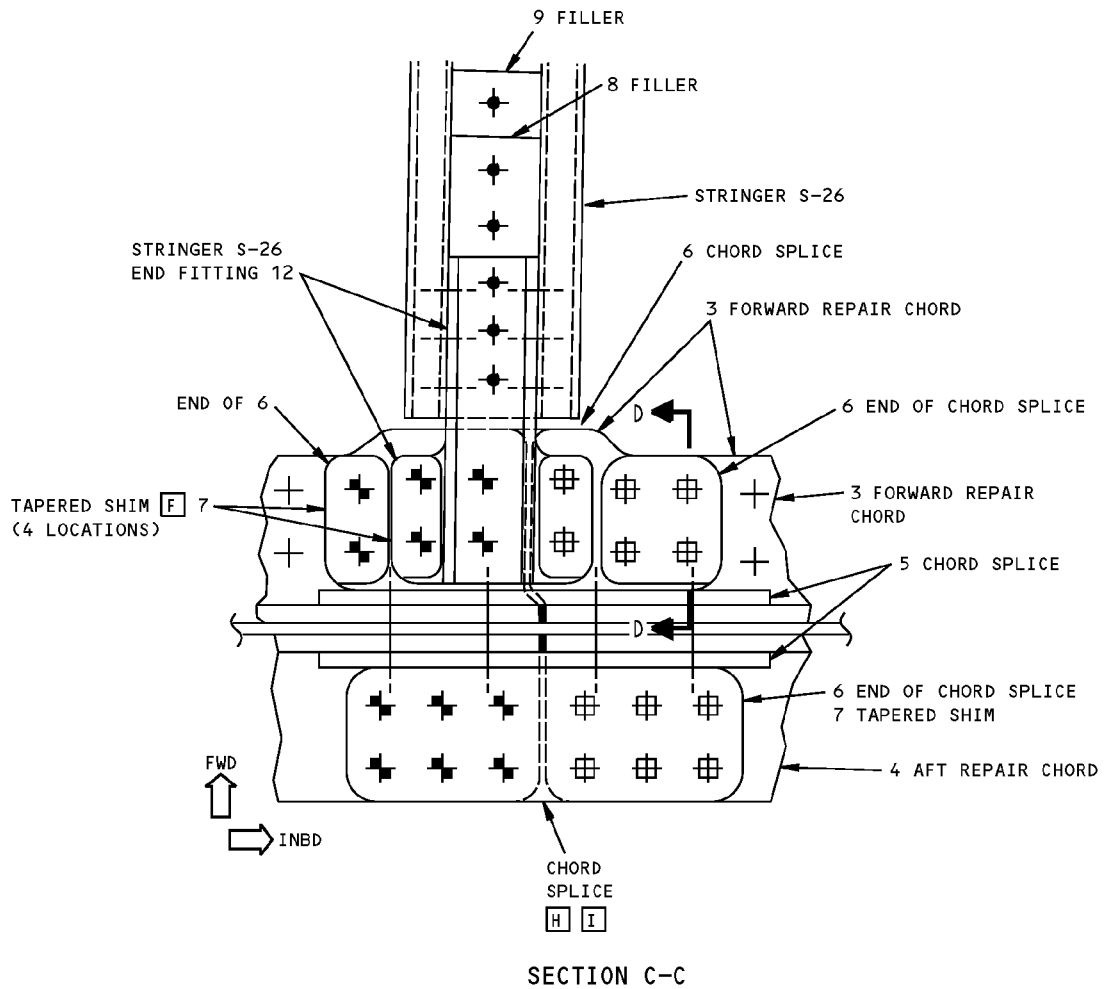
Aft Pressure Bulkhead Lower Web and Chord Repair
Figure 201 (Sheet 3 of 7)

**757-200
STRUCTURAL REPAIR MANUAL**



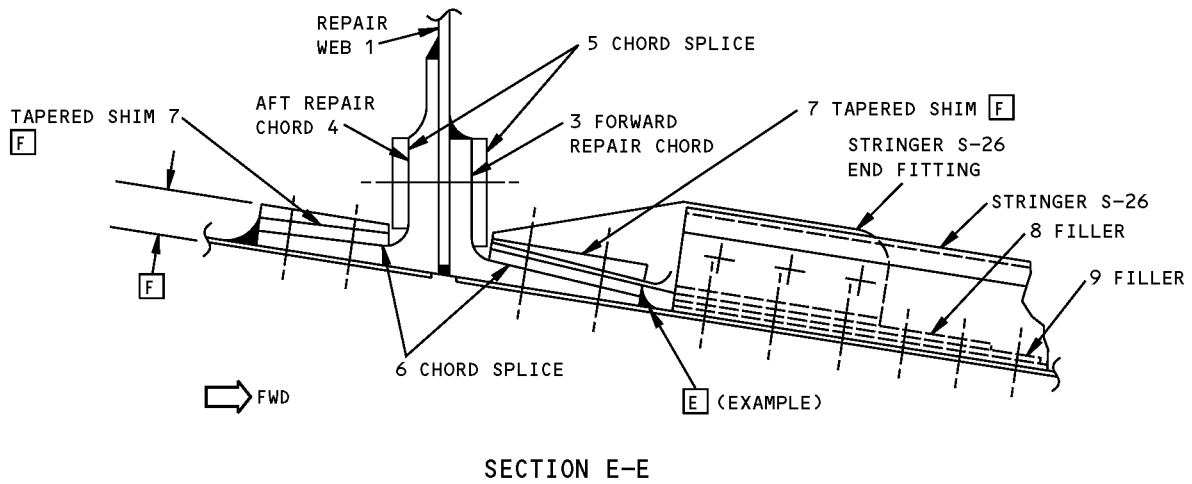
**Aft Pressure Bulkhead Lower Web and Chord Repair
Figure 201 (Sheet 5 of 7)**

**757-200
STRUCTURAL REPAIR MANUAL**



**Aft Pressure Bulkhead Lower Web and Chord Repair
Figure 201 (Sheet 6 of 7)**

**757-200
STRUCTURAL REPAIR MANUAL**



**Aft Pressure Bulkhead Lower Web and Chord Repair
Figure 201 (Sheet 7 of 7)**

**757-200
STRUCTURAL REPAIR MANUAL**

REPAIR 2 - APU FIREWALL WEB CRACK REPAIR BETWEEN STIFFENERS

REPAIR INSTRUCTIONS

1. Refer to SRM 51-10-02 and stopdrill the crack. Penetrant inspect the crack to make sure it is terminated.
2. Optionally, you may cut and remove the damaged part of the web and penetrant inspect it. Make the corners of the cut-out at least 0.25 inch (6 mm) radius. Make the surface 125 microinches or smoother.
3. Make doubler 1. Refer to Detail I for fastener spacing and edge margins.
4. Put the doubler in place on the web and drill the fastener holes.
5. Remove the nicks, burrs, scratches, gouges, and sharp corners from the web and from doubler 1.
6. Remove all the sharp edges from the web and from part 1 doubler 0.015 to 0.030 inch (0.38 to 0.76 mm) radius.
7. Install doubler 1. Apply a fillet seal all the way around the doubler edge on the aft side of the web with BMS 5-63, Type I sealant.

FASTENER SYMBOLS

- ✦ REPAIR FASTENER LOCATION. INSTALL A MS20615-5M RIVET.
- ✚ INITIAL FASTENER LOCATION. INSTALL A MS20615-5M RIVET.

REPAIR MATERIAL			
PART		QTY	MATERIAL
1	DOUBLER	1	0.025 INCH 6AL-4V TITANIUM AS GIVEN COPOSITION C ANNEALED

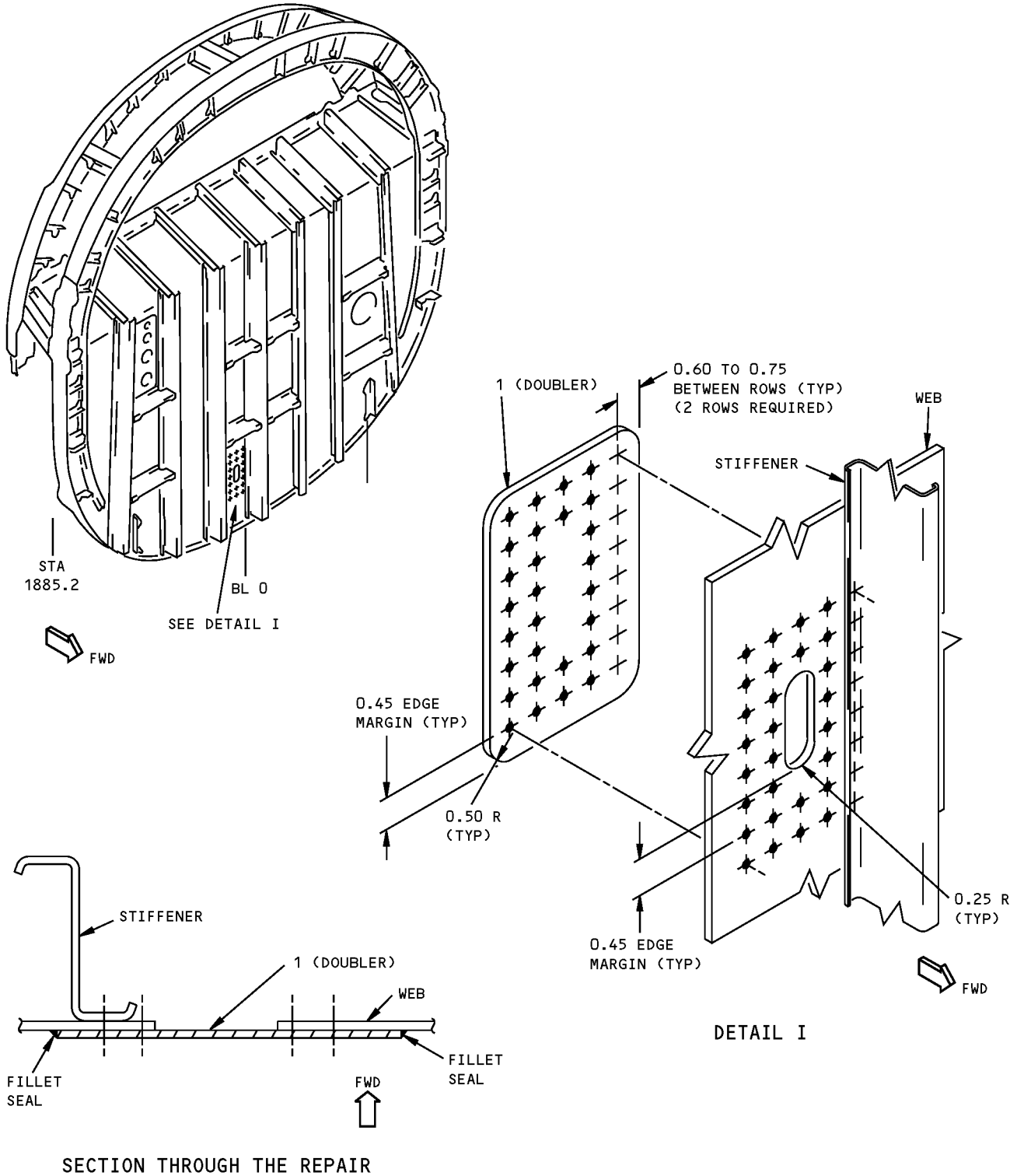
TABLE I

NOTES

- THIS IS A CATEGORY A REPAIR FOR 757-200, 200 COMBI AND 200PF AIRPLANES. THE INSPECTIONS GIVEN IN THE MAINTENANCE PLANNING DATA (MPD) ARE SUFFICIENT TO MAINTAIN THE DAMAGE TOLERANCE OF THE INITIAL STRUCTURE WITH THIS REPAIR INSTALLED. REFER TO SRM 51-00-06 FOR REPAIR CATEGORIES AND DEFINITIONS.
- WHEN YOU USE THIS REPAIR REFER TO:
 - SRM 51-20-05 FOR SEALING OF REPAIRS
 - SRM 51-30-01 PARAGRAPH 3 FOR PRECAUTIONS WHEN WORKING WITH TITANIUM
 - SRM 51-40 FOR FASTENER CODE, INSTALLATION AND REMOVAL, HOLE SIZES, AND EDGE MARGINS
 - SOPM 20-20-02 FOR PENETRANT INSPECTION PROCEDURES.

**APU Firewall Web Crack Repair Between Stiffeners
Figure 201 (Sheet 1 of 2)**

**757-200
STRUCTURAL REPAIR MANUAL**



**APU Firewall Web Crack Repair Between Stiffeners
Figure 201 (Sheet 2 of 2)**

**757-200
STRUCTURAL REPAIR MANUAL**

REPAIR 3 - APU FIREWALL WEB CRACK REPAIR AT A STIFFENER

REPAIR INSTRUCTIONS

1. Remove the necessary fasteners in the repair area.
2. Place a stainless steel sheet between the stringer and the web to protect the stiffener.
3. Refer to SRM 51-10-02 and stopdrill the crack. Penetrant inspect the crack to make sure it is terminated.
4. Optionally, you may cut and remove the damaged part of the web and penetrant inspect it. Make the corners of the cutout at least 0.25 inch (6 mm) radius. Make the surface 125 microinches or smoother.
5. Make doubler 1 and filler 2. Refer to Detail I for fastener spacing and edge margins.
6. Put doubler 1 and filler 2 in place on the web and drill the fastener holes.
7. Remove the nicks, burrs, scratches, gouges, and sharp corners from the web, doubler 1, and filler 2.
8. Remove all the sharp edges from the web, doubler 1, and filler 2 0.015 to 0.030 inch (0.38 to 0.76 mm) radius.
9. Install doubler 1 and filler 2. Apply a fillet seal all the way around the doubler edge on the aft side of the web with BMS 5-63, Type I sealant.

FASTENER SYMBOLS

- ✦ REPAIR FASTENER LOCATION. INSTALL A MS20615-5M RIVET.
- ✚ INITIAL FASTENER LOCATION. INSTALL A MS20615-5M RIVET.

REPAIR MATERIAL			
PART		QTY	MATERIAL
1	DOUBLER	1	0.025 INCH 6AL-4V TITANIUM TYPE III COMP-C ANNEALED
2	FILLER	1	0.016 INCH 6AL-4V TITANIUM TYPE III COMP-C ANNEALED

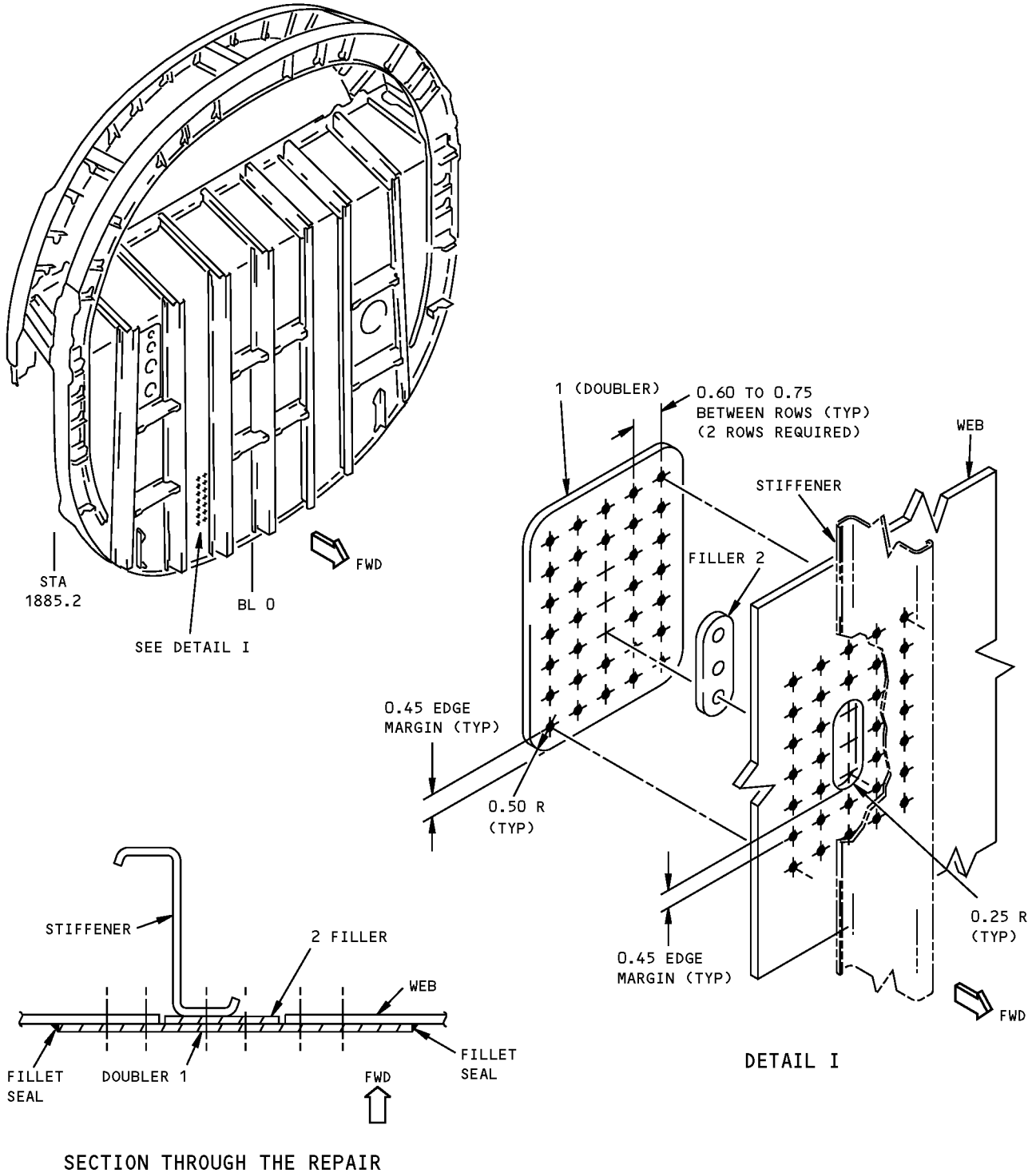
TABLE I

NOTES

- THIS IS A CATEGORY A REPAIR FOR 757-200, 200 COMBI AND 200PF AIRPLANES. THE INSPECTIONS GIVEN IN THE MAINTENANCE PLANNING DATA (MPD) ARE SUFFICIENT TO MAINTAIN THE DAMAGE TOLERANCE OF THE INITIAL STRUCTURE WITH THIS REPAIR INSTALLED. REFER TO SRM 51-00-06 FOR REPAIR CATEGORIES AND DEFINITIONS.
- WHEN YOU USE THIS REPAIR REFER TO:
 - SRM 51-20-05 FOR SEALING OF REPAIRS
 - SRM 51-30-01 PARAGRAPH 3 FOR PRECAUTIONS WHEN WORKING WITH TITANIUM
 - SRM 51-40 FOR FASTENER CODE, INSTALLATION AND REMOVAL, HOLE SIZES, AND EDGE MARGINS
 - SOPM 20-20-02 FOR PENETRANT INSPECTION PROCEDURES.

**APU Firewall Web Crack Repair at a Stiffener
Figure 201 (Sheet 1 of 2)**

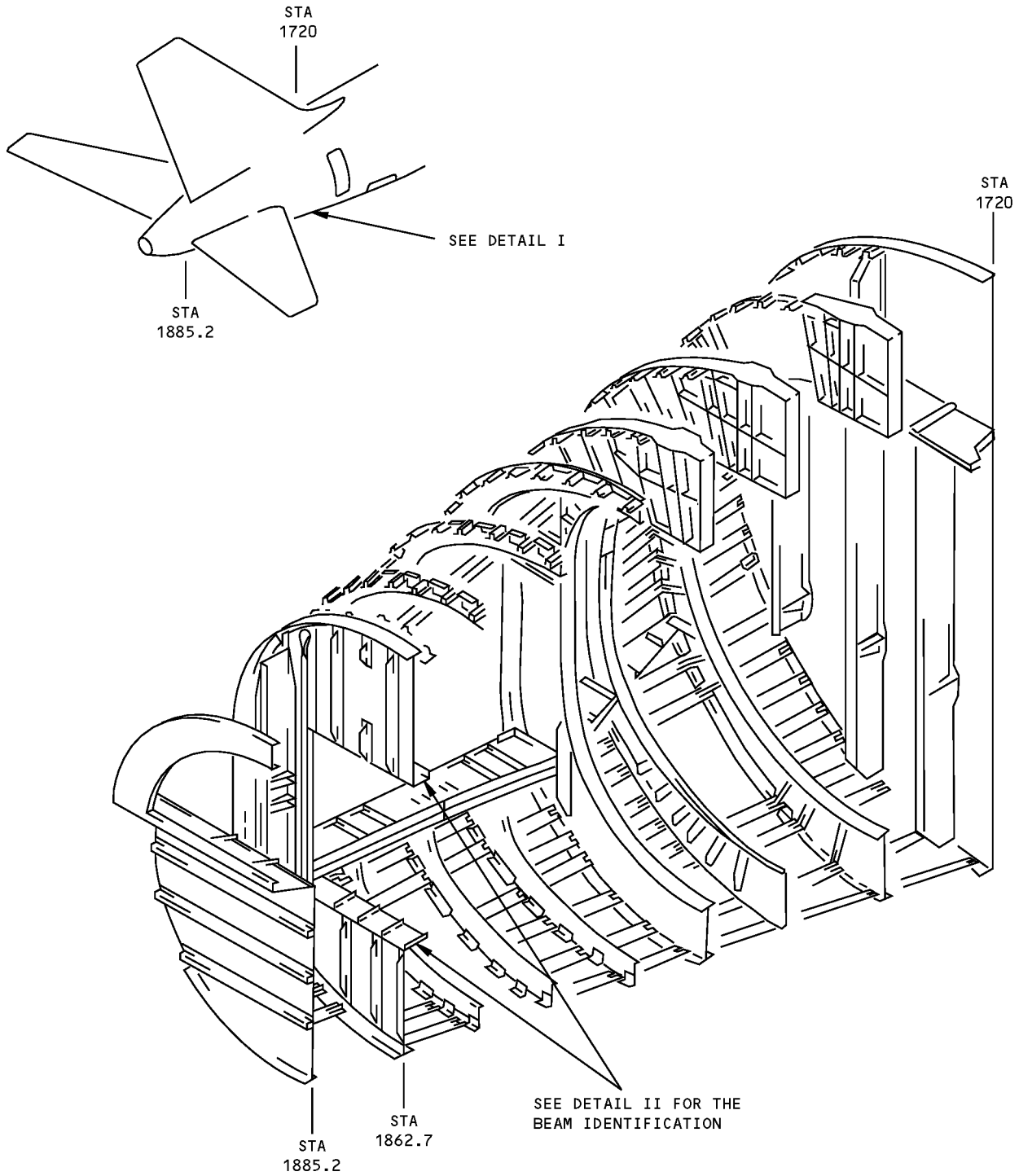
**757-200
STRUCTURAL REPAIR MANUAL**



**APU Firewall Web Crack Repair at a Stiffener
Figure 201 (Sheet 2 of 2)**

**757-200
STRUCTURAL REPAIR MANUAL**

IDENTIFICATION 1 - SECTION 48 - BEAMS

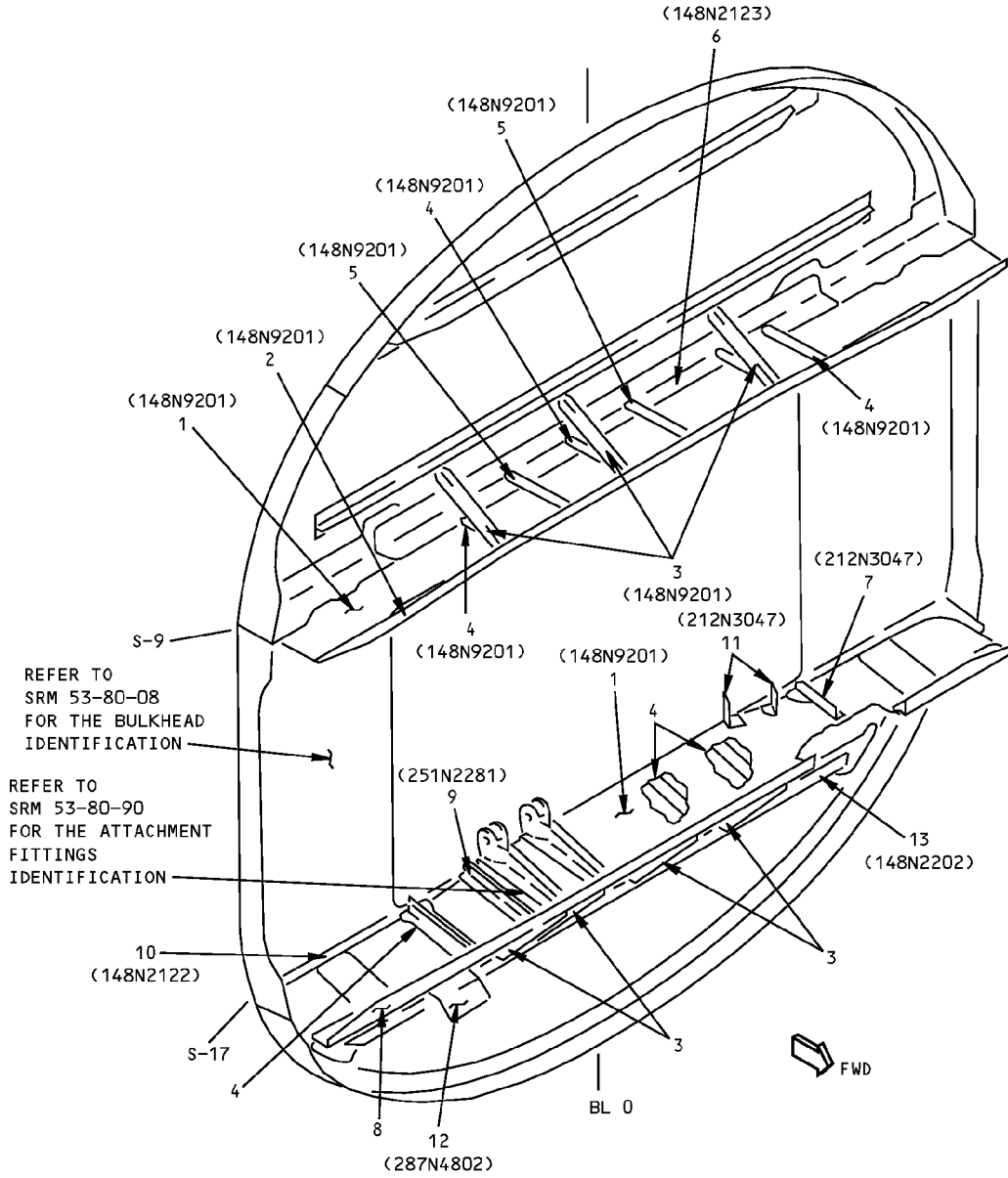


DETAIL I

**Section 48 Beam Identification
Figure 1 (Sheet 1 of 3)**

**757-200
STRUCTURAL REPAIR MANUAL**

REFERENCE DRAWING
148N9203



REFER TO
SRM 53-80-08
FOR THE BULKHEAD
IDENTIFICATION

REFER TO
SRM 53-80-90
FOR THE ATTACHMENT
FITTINGS
IDENTIFICATION

REAR VIEW BULKHEAD
STA 1862.7
DETAIL II

LIST OF
MATL

**Section 48 Beam Identification
Figure 1 (Sheet 2 of 3)**

IDENTIFICATION 1
Page 2
Jan 20/2005

53-80-13

D634N201



**757-200
STRUCTURAL REPAIR MANUAL**

ITEM	DESCRIPTION	GAGE	MATERIAL	EFFECTIVITY
1	WEB	0.032	7075-T6	
2	CHORD		AND10136-2407 2024-T3511	
3	BRACE		AND10136-2002 7075-T6511	
4	STIFFENER		AND10134-1205 7075-T6511	
5	STIFFENER		AND10133-1002 7075-T6511	
6	CHORD		BAC1514-1847 7075-T6511	
7	STIFFENER		BAC1505-100569 7075-T6511	
8	CHORD		AND10134-2006 2024-T3511	
9	ANGLE		AND10134-0702 2024-T3511	
10	CHORD		BAC1514-2208 7075-T6511	
11	BRACKET	0.08	2024-T42	
12	BRACKET	0.05	2024-T42	
13	STIFFENER		AND10136-3001 7075-T6511	

LIST OF MATERIALS FOR DETAIL II

**Section 48 Beam Identification
Figure 1 (Sheet 3 of 3)**

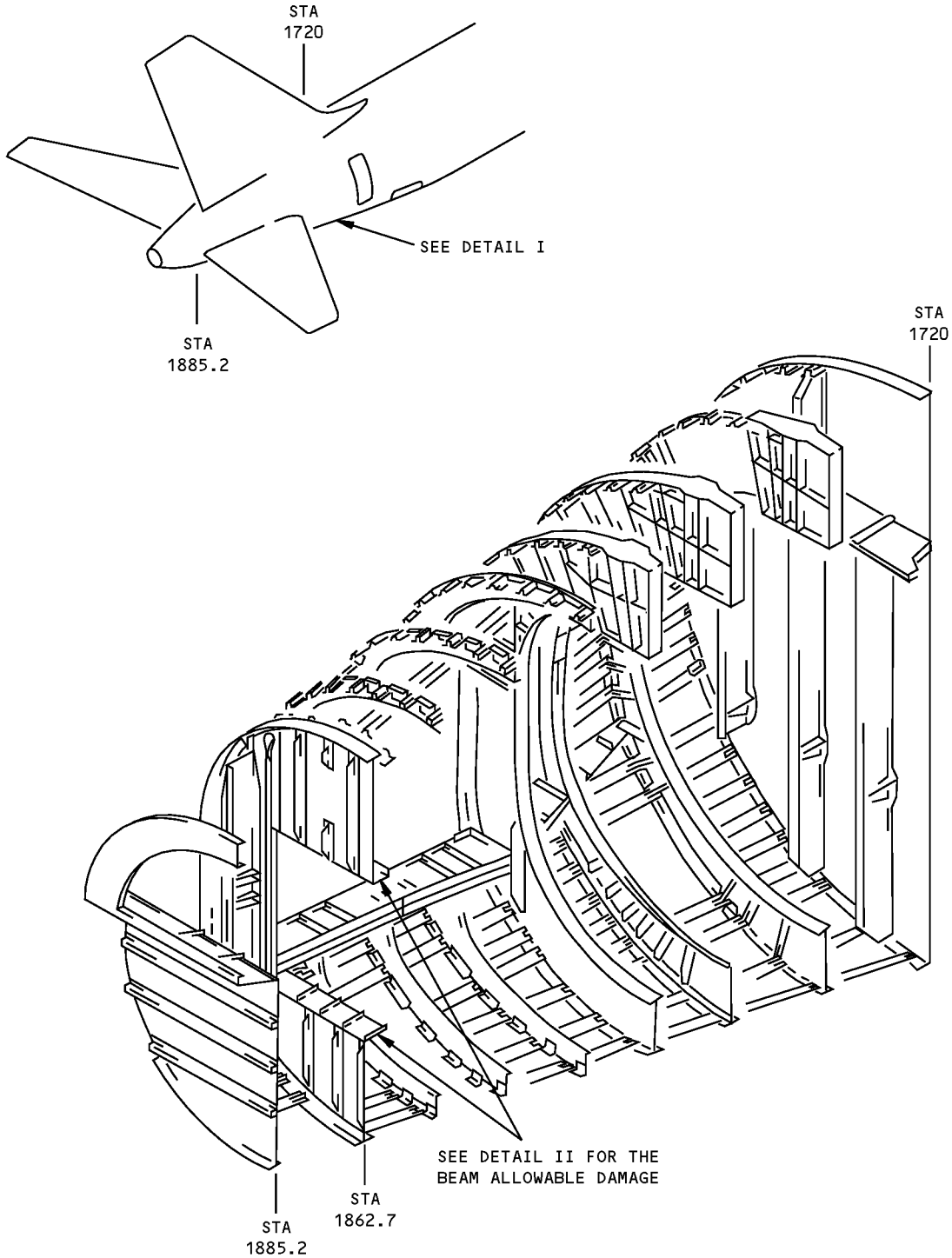
D634N201

53-80-13

IDENTIFICATION 1
Page 3
Jan 20/2005

**757-200
STRUCTURAL REPAIR MANUAL**

ALLOWABLE DAMAGE 1 - SECTION 48 - BEAMS

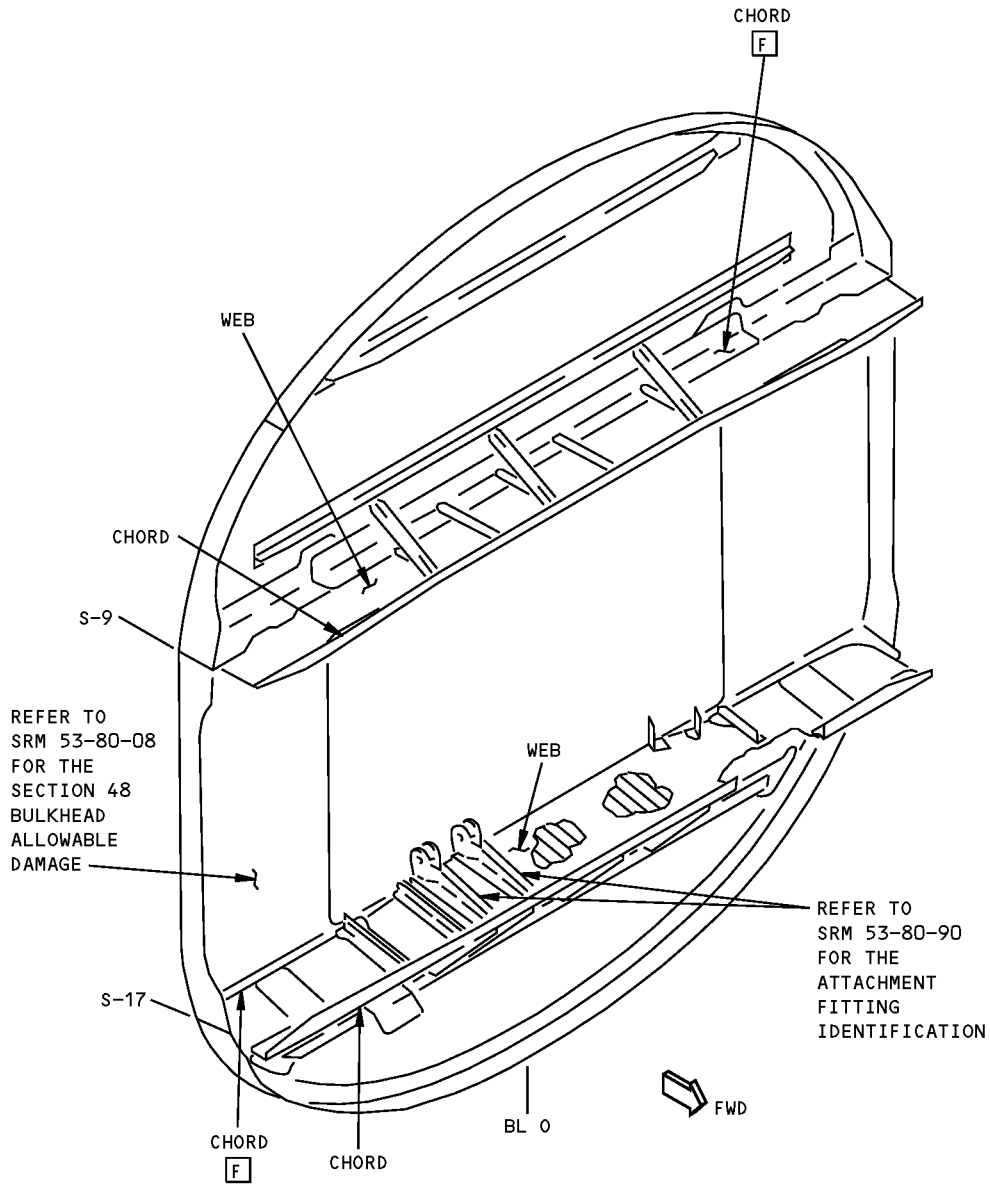


DETAIL I

**Section 48 Beam Allowable Damage
Figure 101 (Sheet 1 of 5)**

**757-200
STRUCTURAL REPAIR MANUAL**

REFERENCE DRAWING
148N9203



REAR VIEW BULKHEAD
STA 1862.7
DETAIL II

MATERIAL: ALUMINUM

**Section 48 Beam Allowable Damage
Figure 101 (Sheet 2 of 5)**

ALLOWABLE DAMAGE 1
Page 102
Jan 20/2005

53-80-13

D634N201



757-200
STRUCTURAL REPAIR MANUAL

DESCRIPTION	CRACKS	NICKS, GOUGES AND CORROSION	DENTS	HOLES AND PUNCTURES
WEBS	A	B	SEE DETAIL V	C
CHORDS	D	E	NOT PERMITTED	NOT PERMITTED

NOTES

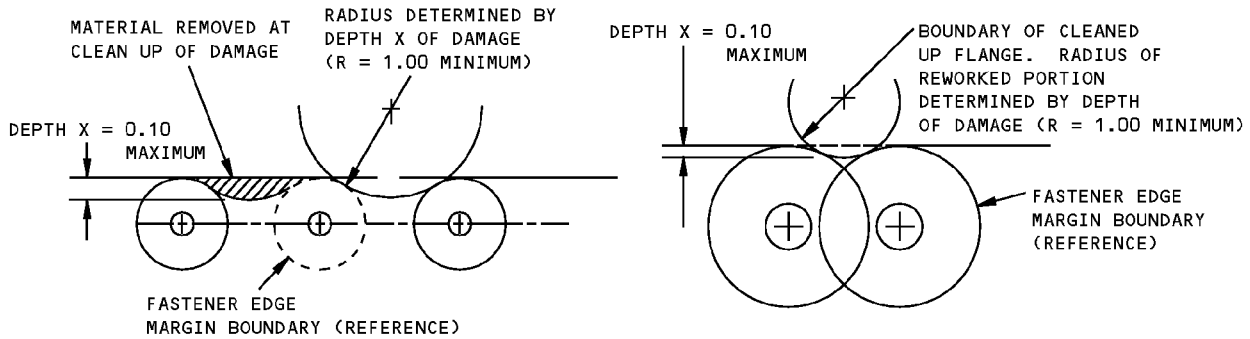
- FOR THE PROTECTIVE TREATMENT OF THE REWORKED AREAS, REFER TO AMM 51-20 AND SRM 51-20-01.
- A** CRACKS ARE NOT PERMITTED EXCEPT FOR EDGE CRACKS, WHICH MUST BE REMOVED AS SHOWN IN DETAILS III AND VII.
- B** REMOVE THE DAMAGE AS SHOWN IN DETAILS III, IV, AND VI.
- C** REMOVE THE HOLE DAMAGE UP TO 0.25 INCH IN DIAMETER IF IT IS A MINIMUM OF 1.0 INCH AWAY FROM A FASTENER HOLE, AND EDGE, OR OTHER DAMAGE. FILL THE HOLE WITH A 2117-T3 OR T-4 ALUMINUM PROTRUDING HEAD RIVET. INSTALL THE RIVET WITHOUT SEALANT.
- D** CRACKS ARE NOT PERMITTED EXCEPT FOR EDGE CRACKS WHICH MUST BE REMOVED AS SHOWN IN DETAILS III AND VIII. REFER TO DETAIL II FOR THE AREAS WHERE SHOT PEENING IS NECESSARY.
- E** REMOVE THE DAMAGE AS SHOWN IN DETAILS III, IV, AND VI. REFER TO DETAIL II FOR THE AREAS WHERE SHOT PEENING IS NECESSARY.
- F** SHOT PEEN THE REWORKED AREAS WITH NO. 230-250, INTENSITY .008A **G** AS GIVEN IN SOPM 20-10-03.
- G** SHOT PEEN INTENSITIES WILL VARY WITH THE THICKNESS REMAINING AFTER REWORK. REFER TO SRM 51-20-06 AND SOPM 20-10-03.

Section 48 Beam Allowable Damage
Figure 101 (Sheet 3 of 5)

D634N201

ALLOWABLE DAMAGE 1
53-80-13
Page 103
Jan 20/2005

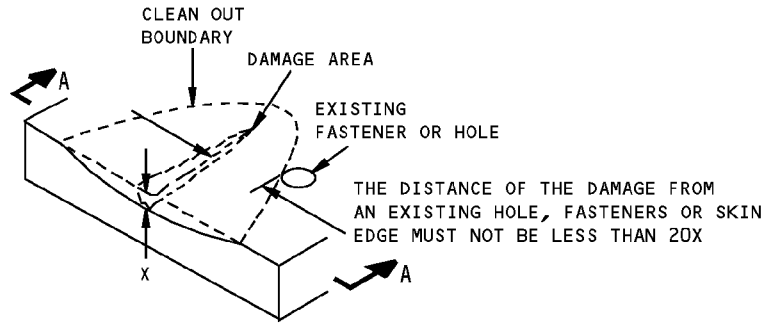
**757-200
STRUCTURAL REPAIR MANUAL**



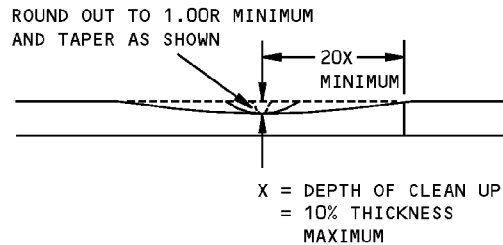
DAMAGE CLEAN UP OF EDGES WHERE
FASTENER EDGE MARGINS DO NOT OVERLAP

DAMAGE CLEAN UP OF EDGES WHERE
FASTENER EDGE MARGINS OVERLAP

DETAIL III



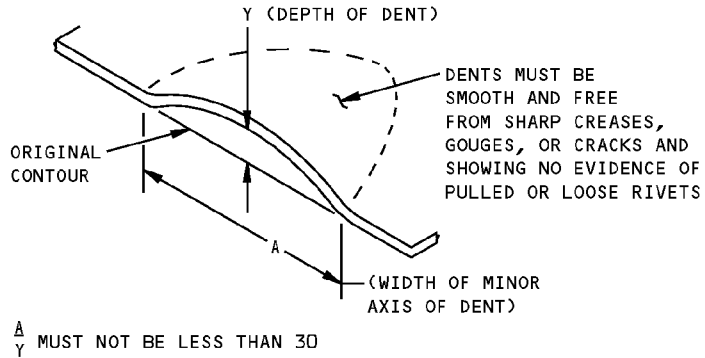
REMOVAL OF NICK, GOUGE AND
SCRATCH DAMAGE ON A SURFACE
DETAIL IV



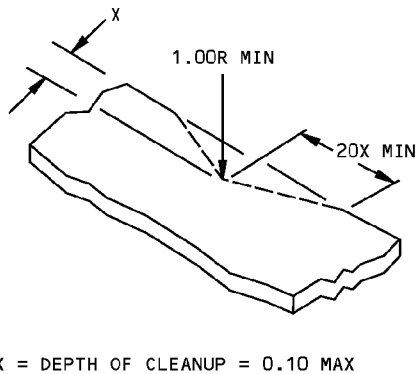
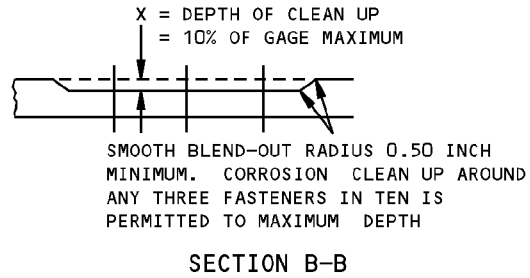
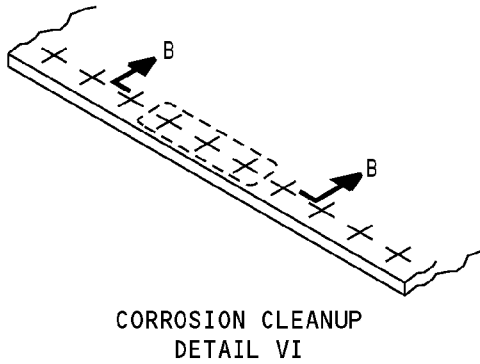
SECTION A-A

**Section 48 Beam Allowable Damage
Figure 101 (Sheet 4 of 5)**

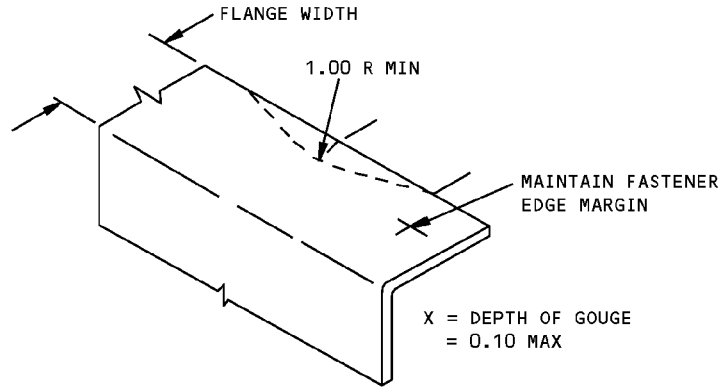
STRUCTURAL REPAIR MANUAL



ALLOWABLE DAMAGE FOR DENT
DETAIL V



DETAIL VII



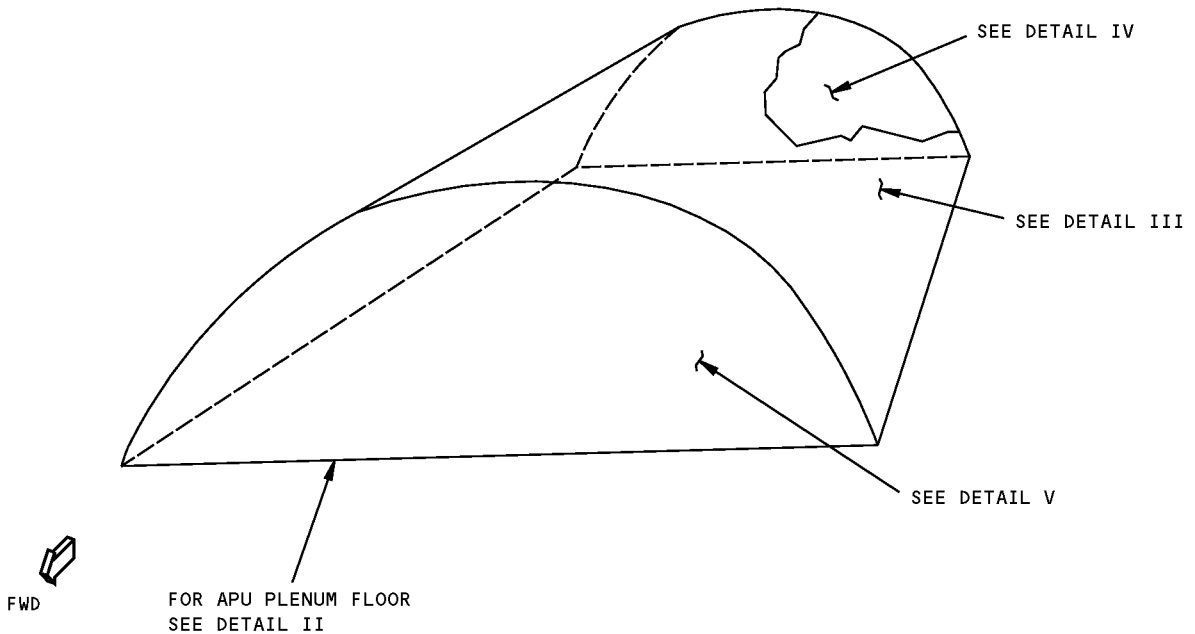
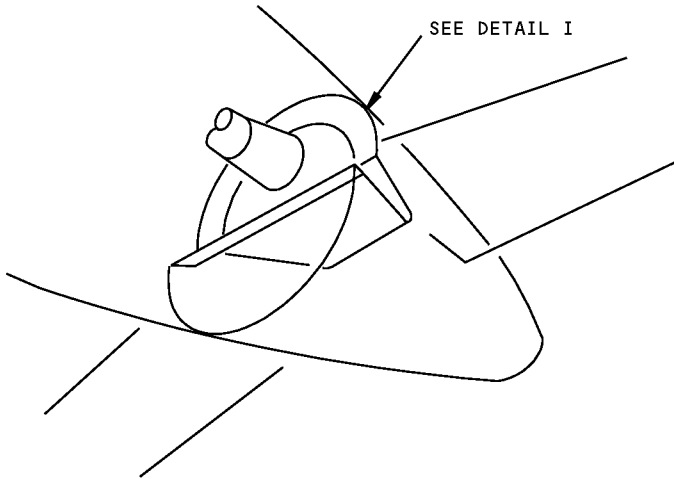
REMOVAL OF NICK OR CRACK
DAMAGE ON AN EDGE
DETAIL VIII

Section 48 Beam Allowable Damage
Figure 101 (Sheet 5 of 5)

**757-200
STRUCTURAL REPAIR MANUAL**

IDENTIFICATION 1 - APU PLENUM

REF DWG
353N4010

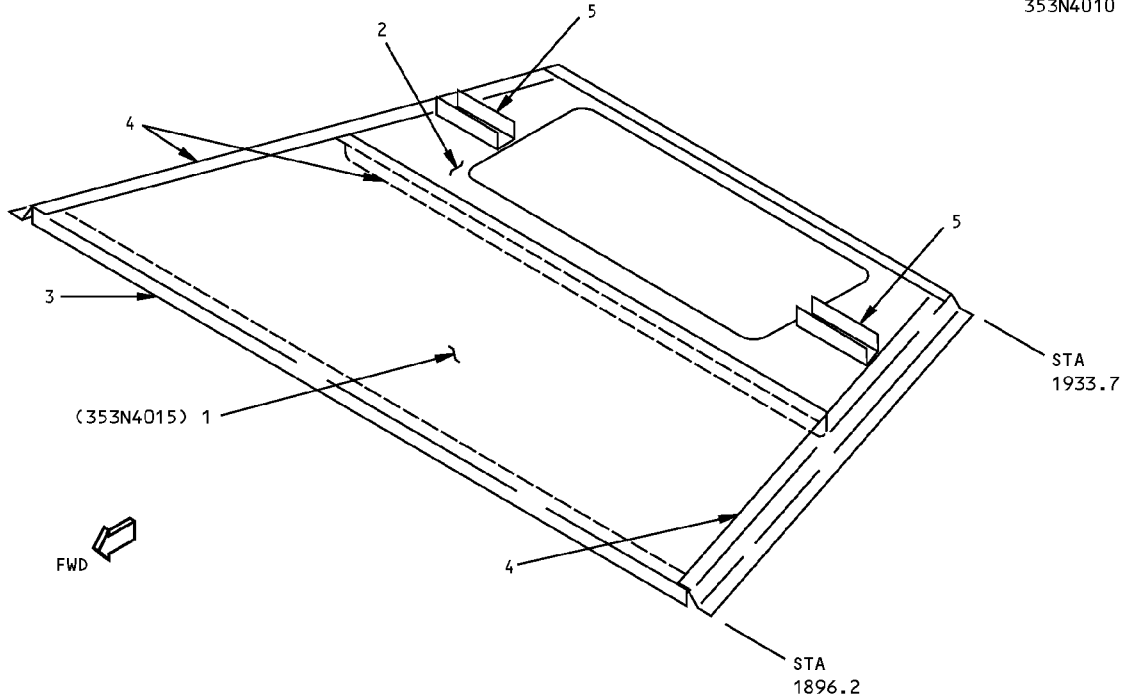


DETAIL I

**APU Plenum Identification
Figure 1 (Sheet 1 of 5)**

**757-200
STRUCTURAL REPAIR MANUAL**

REF DWG
353N4010



DETAIL II

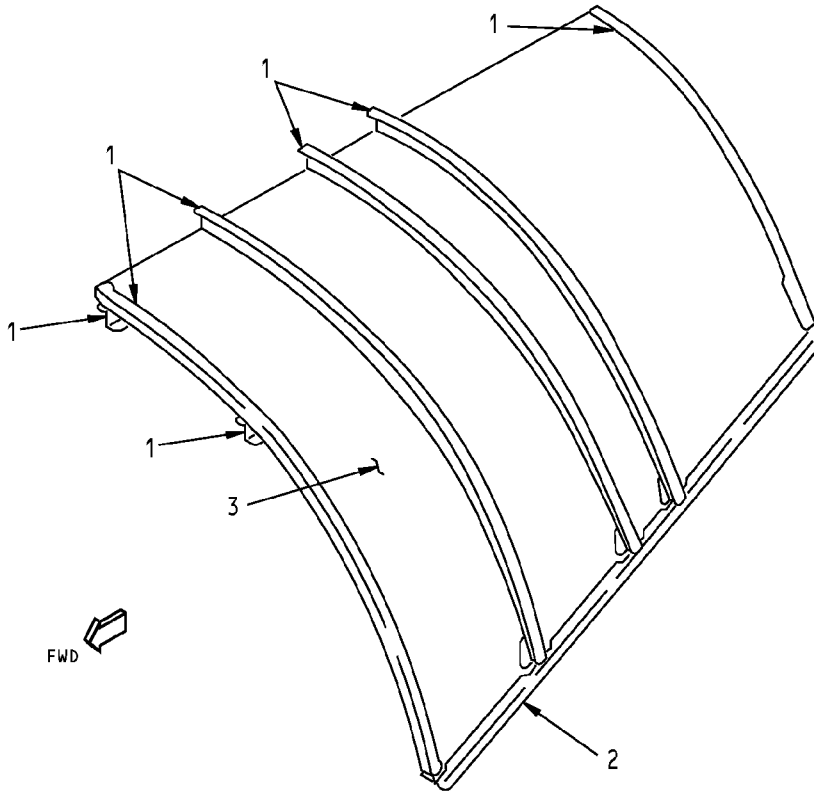
ITEM	DESCRIPTION	GAGE	MATERIAL	EFFECTIVITY
1	PLENUM FLOOR SKIN CORE (EDGE BAND) CORE (CENTER)	0.020	ANNEALED TI-6AL-4V TITANIUM HONEYCOMB CORE TI-3AL-2.5V PER BMS 7-211, SC2-20NF, COMP 2 PER BMS 4-12 TITANIUM HONEYCOMB CORE TI-3AL-25V PER BMS 7-211, SC4-20NF, COMP C PER BMS 4-12	
2	PLENUM FLOOR	0.020	ANNEALED TI-6AL-4V	
3	ANGLE	0.025	17-7PH CRES HEAT-TREAT 180-200 KSI	
4	ANGLE	0.063	17-7PH CRES HEAT-TREAT 180-200 KSI	
5	STIFFENER	0.040	ANNEALED TI-6AL-4V	
6	ANGLE	0.050	17-7PH CRES HEAT-TREAT 180-200 KSI	

LIST OF MATERIALS FOR DETAIL II

**APU Plenum Identification
Figure 1 (Sheet 2 of 5)**

**757-200
STRUCTURAL REPAIR MANUAL**

REF DWG
353N4010



LEFT SIDE SHOWN
RIGHT SIDE OPPOSITE
DETAIL III

ITEM	DESCRIPTION	GAGE	MATERIAL	EFFECTIVITY
1	ZEE	0.050	17-7PH CRES HEAT TREAT 180-200 KSI	
2	ANGLE	0.063	17-7PH CRES HEAT TREAT 180-200 KSI	
3	SKIN	0.032	ANNEALED TI-6AL-4V	

LIST OF MATERIALS FOR DETAIL III

**APU Plenum Identification
Figure 1 (Sheet 3 of 5)**

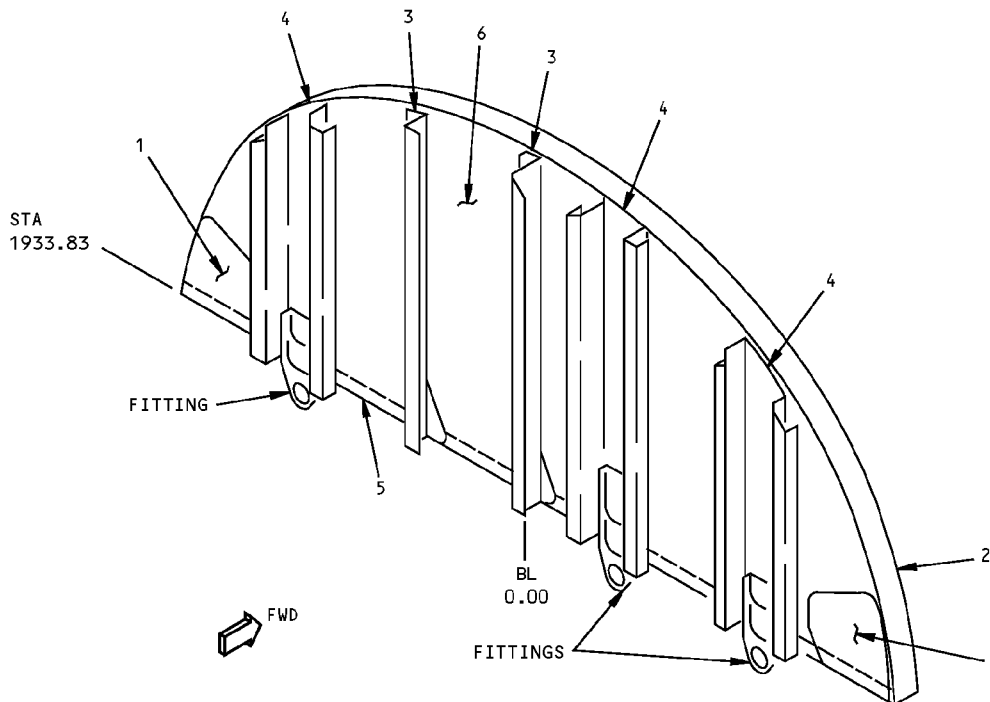
IDENTIFICATION 1
Page 3
Jan 20/2005

53-80-30

D634N201

**757-200
STRUCTURAL REPAIR MANUAL**

REF DWG
353N4010



DETAIL IV

ITEM	DESCRIPTION	GAGE	MATERIAL	EFFECTIVITY
1	GUSSET	0.040	17-7PH CRES HEAT TREAT 180-200 KSI	
2	FLANGE	0.050	17-7PH CRES HEAT TREAT 151-170 KSI	
3	ZEE	0.040	17-7PH CRES HEAT TREAT 151-170 KSI	
4	CHANNEL	0.032	17-7PH CRES HEAT TREAT 151-170 KSI	
5	ANGLE	0.050	17-7PH CRES HEAT TREAT 180-200 KSI	
6	SKIN	0.032	ANNEALED TI-6AL-4V	

LIST OF MATERIALS FOR DETAIL IV

**APU Plenum Identification
Figure 1 (Sheet 4 of 5)**

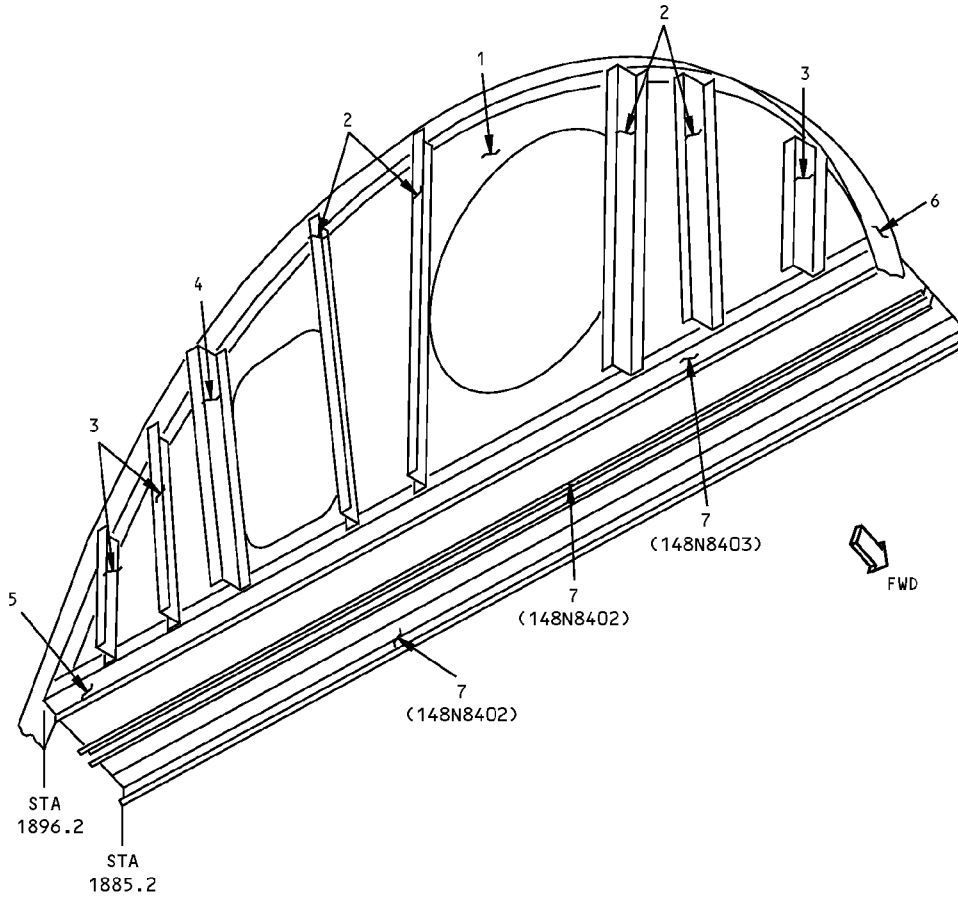
IDENTIFICATION 1
Page 4
Jan 20/2005

53-80-30

D634N201

**757-200
STRUCTURAL REPAIR MANUAL**

REF DWG
353N4010



DETAIL V

ITEM	DESCRIPTION	GAGE	MATERIAL	EFFECTIVITY
1	SKIN	0.032	TI-6AL-4V	
2	ZEE	0.050	17-7PH CRES	
3	ZEE	0.040	17-7PH CRES	
4	ANGLE	0.050	17-7PH CRES	
5	ANGLE	0.025	17-7PH CRES	
6	OUTER CHORD	0.050	17-7PH CRES	
7	ANGLE	0.050	TI-6AL-4V	

LIST OF MATERIALS FOR DETAIL V

**APU Plenum Identification
Figure 1 (Sheet 5 of 5)**

IDENTIFICATION 1
Page 5
Jan 20/2005

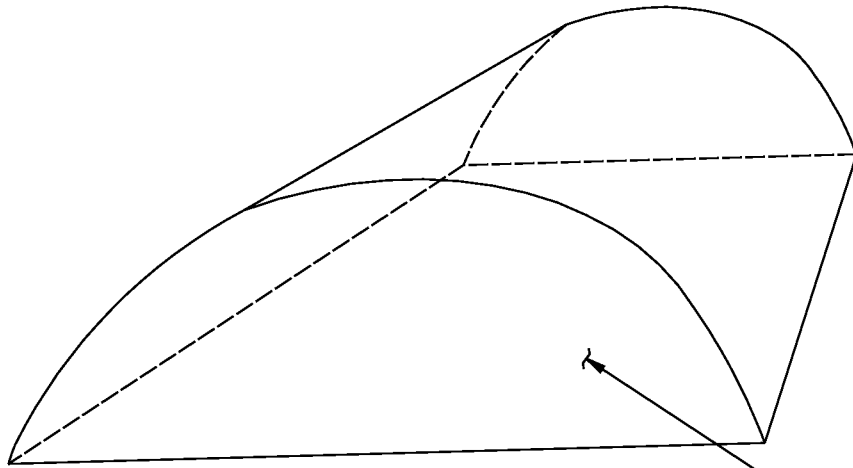
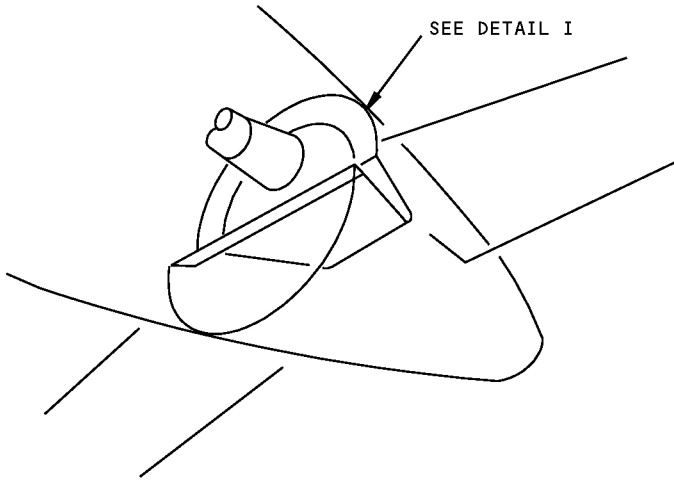
53-80-30

D634N201

**757-200
STRUCTURAL REPAIR MANUAL**

ALLOWABLE DAMAGE 1 - APU PLENUM

REF DWG
353N4010



SEE 53-80-08, FIGURE 101
FOR ALLOWABLE DAMAGE
LIMITS FOR THE APU
PLENUM ASSEMBLY
BULKHEAD AT
STA 1896.2

DETAIL I

**APU Plenum Allowable Damage
Figure 101**

D634N201



**757-200
STRUCTURAL REPAIR MANUAL**

REPAIR GENERAL - SERVICE BULLETIN REPAIR CHART

SERVICE BULLETIN REPAIRS

The following Service Bulletins contain repairs which are available for use where specific damage has been encountered. Usually, the Service Bulletin also covers preventive modification data which operators are encouraged to use to eliminate the need for repair.

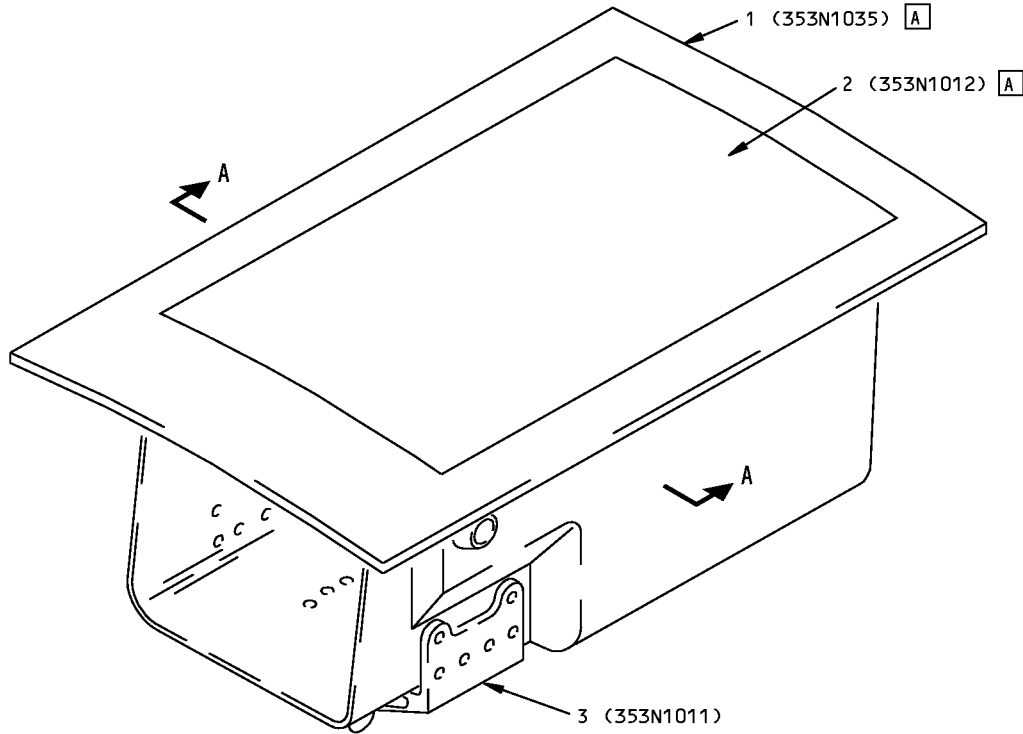
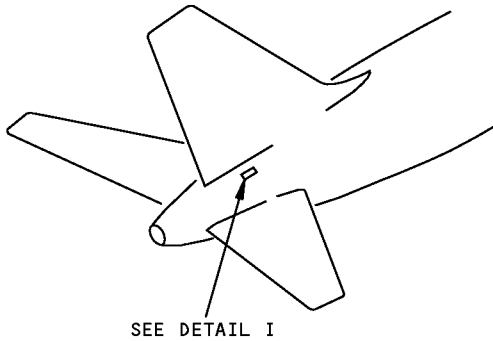
DAMAGED AREA	CUM LINE NUMBER EFFECTIVITY	SB NUMBER
AIRBORNE AUXILIARY POWER - AIR INTAKE PLENUM - BELLMOUTH MODIFICATION	1 THRU 175, 177 THRU 180, 182-183, 185	757-49-0011

**Service Bulletin Repair Chart
Figure 201**

**757-200
STRUCTURAL REPAIR MANUAL**

IDENTIFICATION 1 - AUXILIARY POWER UNIT AIR INLET DOOR

REFERENCE DRAWINGS
353N1001
353N1010
353N1020
353N1035



DETAIL I

NOTES

[A] PLY LAYUP VARIES THROUGH-OUT BONDED DOOR AND FRAME ASSEMBLY. SEE ENGINEERING DRAWINGS FOR CONFIGURATIONS.

1539786 S0000280177_V1

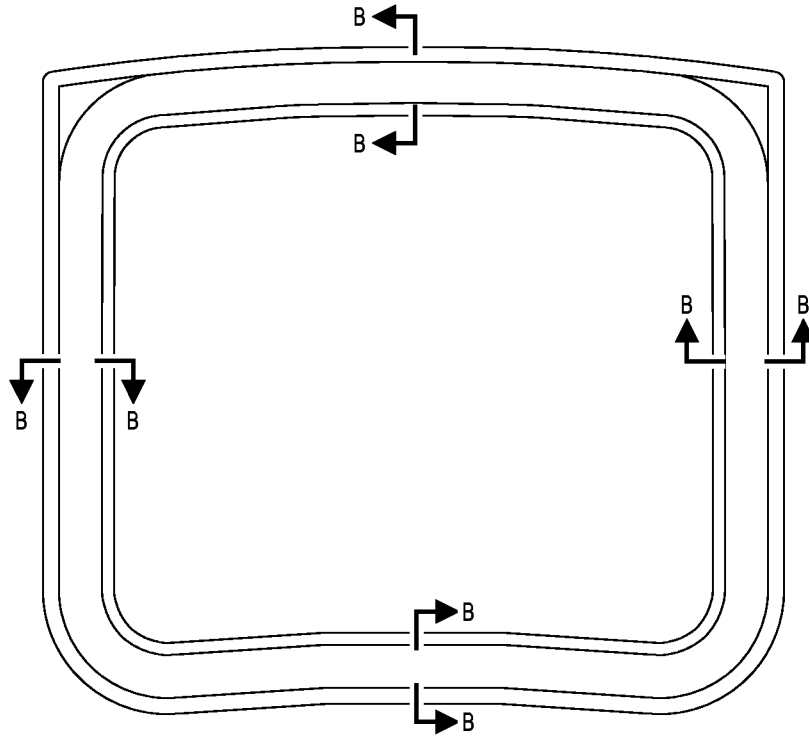
**APU Intake Port - Frame/Door Structure Identification
Figure 1 (Sheet 1 of 2)**

D634N201

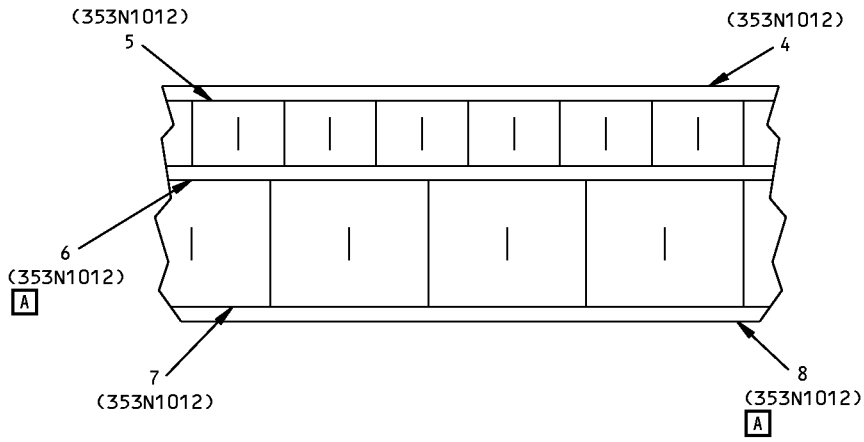
53-80-31

IDENTIFICATION 1
Page 1
May 20/2008

**757-200
STRUCTURAL REPAIR MANUAL**



SECTION A-A



ROTATED 90° COUNTER CLOCKWISE
SECTION B-B

1555674 S0000286711_V1

**APU Intake Port - Frame/Door Structure Identification
Figure 1 (Sheet 2 of 2)**

D634N201

53-80-31

IDENTIFICATION 1
Page 2
May 20/2008



**757-200
STRUCTURAL REPAIR MANUAL**

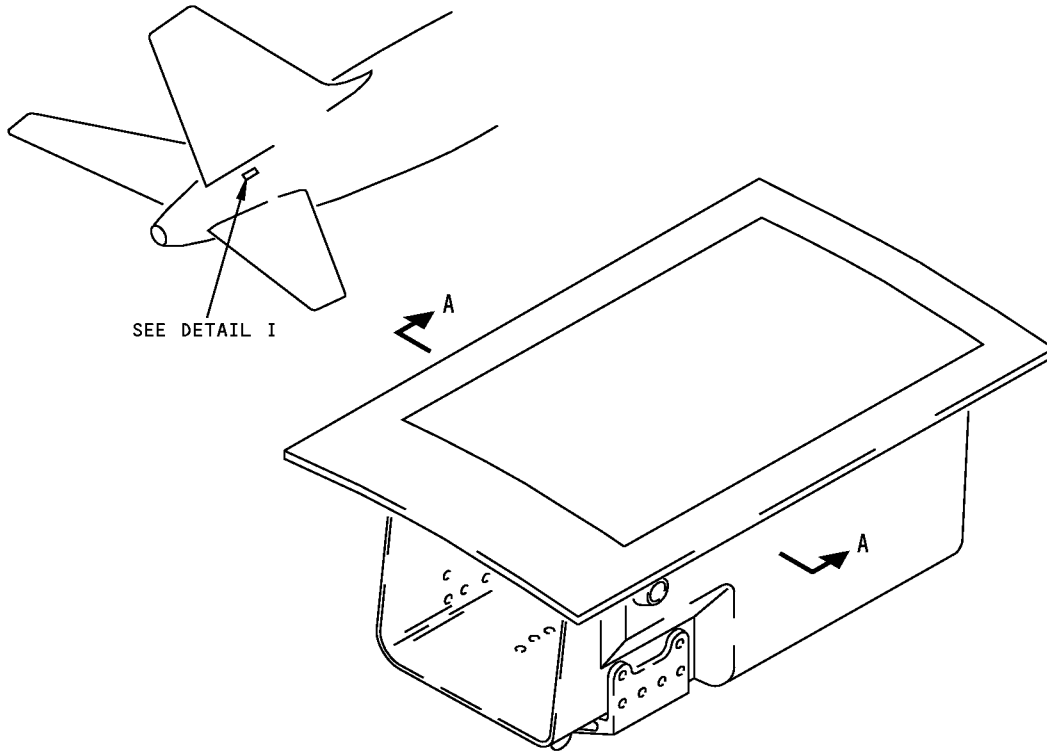
List of Materials

Item	Description	Gage	Material	Basic Effectivity
1	Frame		Fiberglass/graphite/epoxy laminate Fiberglass plies - BMS 8-79, Type 120 Graphite plies - BMS 8-168, Type 2, Class 2, Style 3K-50PW	
2	Bonded Door Assembly		Fiberglass/epoxy honeycomb sandwich	
	Door		Fiberglass cloth epoxy per BMS 8-79, Style 1581, 1584, 7781	
	Inner Core		Non-metallic honeycomb per BMS 8-124, Class I, Type III	
	Outer Core		Non-metallic honeycomb per BMS 8-124, Class IV, Type V	
3	Actuator Fitting		Aluminum casting 356-T6	
4	Acoustic Liner		Brunswick FM1810 (Optional Brunswick 347-50-20-AC3A) (Optional Facet 1739793-02)	
5	Acoustic Core		Non-metallic honeycomb core BMS 8-124, Class 1, Type III, Grade 3.5	N0001-N0177 N2701-N2718 N3001-N3116 N9901
			Non-metallic honeycomb core BMS 8-124, Class 1, Type III, Grade 3.5 OR Non metallic honeycomb core BMS 8-124, Class 1, Type VII, Grade 3.5 to Grade 4.5	N0178-N2699 N2719-N2999 N3117-N7017 N8001-N8023 N8701-N8703 N9001-N9007 N9902-N9990
			Non metallic honeycomb core BMS 8-124, Class 1, Type VII, Grade 3.5 to Grade 4.5 (Optional non-metallic honeycomb core BMS 8-124, Class 1, Type III, Grade 3.5)	N7081-N7077 N8024-N8119 N8704-N8729 N9008-N9009
6	Inner Fiberglass		Fiberglass/epoxy laminate Fiberglass plies - BMS 8-79, Style 1581, 1584, 7781	
7	Structural Core		Non-metallic honeycomb core BMS 8-124, Class IV, Type V, Grade 3.0	
8	Outer Fiberglass		Fiberglass/epoxy laminate Fiberglass plies - BMS 8-79, Style 1581, 1584, 7781	

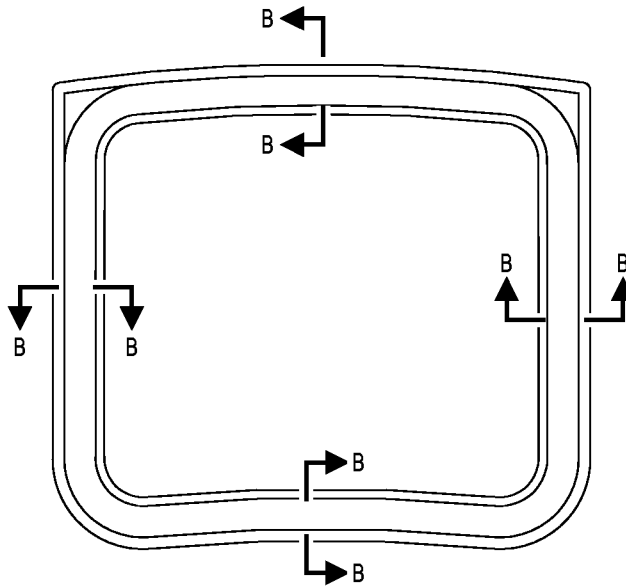
**757-200
STRUCTURAL REPAIR MANUAL**

ALLOWABLE DAMAGE 1 - AUXILIARY POWER UNIT AIR INLET DOOR

REFERENCE DRAWINGS
353N1001
353N1010
353N1020
353N1035



DETAIL I



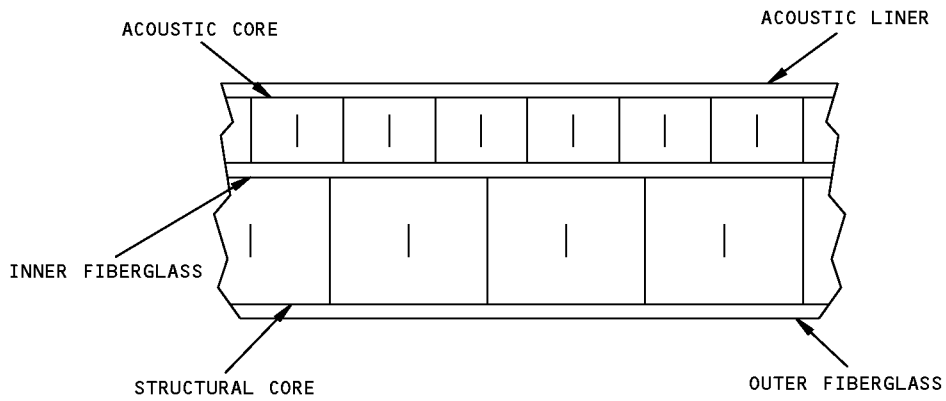
SECTION A-A

1542337 S0000281716_V1

**APU Intake Port - Frame/Door Structure Allowable Damage
Figure 101 (Sheet 1 of 2)**

757-200
STRUCTURAL REPAIR MANUAL

REFERENCE DRAWINGS
353N1001
353N1010
353N1020
353N1035



ROTATED 90° COUNTER CLOCKWISE
SECTION B-B

NOTE:

- NO DAMAGE IS PERMITTED.

1542351 S0000281723_V1

APU Intake Port - Frame/Door Structure Allowable Damage
Figure 101 (Sheet 2 of 2)

ALLOWABLE DAMAGE 1
Page 102
May 20/2008

53-80-31

D634N201



757-200

STRUCTURAL REPAIR MANUAL

REPAIR 1 - ACOUSTIC LINER DAMAGE BETWEEN 0.5 INCHES AND 3.0 INCHES IN DIAMETER

1. Applicability

- A. This repair is applicable to damage to the acoustic liner of the air inlet door of the Auxiliary Power Unit (APU). The diameter of the damage must be between 0.5 in. (12.7 mm) and 3.0 in. (76.2 mm).
- B. This repair is not applicable if you find damage on the adjacent acoustic core.
- C. This repair is not applicable if repairs other than Repair 1 have been done to the door assembly. If repairs other than Repair 1 have been done, contact The Boeing Company.
- D. You can use this repair on a maximum of two damage locations on each door assembly. The edge distance between damage locations must be a minimum of four times the diameter of the largest disbond. If there are more than two damage locations, contact The Boeing Company.

2. General

CAUTION: DO NOT USE CHLORINATED SOLVENTS. DAMAGE TO THE CORE MATERIAL WILL OCCUR.

- A. Clean all parts before you inspect the damage.

3. References

Reference	Title
51-70-03	GRAPHITE AND/OR ARAMID REINFORCED EPOXY LAMINATES AND NONMETALLIC HONEYCOMB SANDWICH REPAIRS - ROOM TEMPERATURE/150°F (66°C) CURE (WET LAYUP)
51-70-09	METAL-TO-METAL STRUCTURAL REPAIR ADHESIVE BOND PROCEDURES
51-70-17	REPAIRS TO 250°F (121°C) AND 350°F (177°C) CURED GRAPHITE/ARAMID/FIBERGLASS REINFORCED EPOXY LAMINATES AND NONMETALLIC HONEYCOMB SANDWICH STRUCTURE - 200°F (93°C) TO 230°F (110°C) WET LAYUP REPAIR METHOD
NDT Part 1, 51-01-01	Inspection of Repairs to Composite Structures
NDT Part 1, 51-05-01	Tap Test Inspection of Honeycomb Sandwich Structure
NDT Part 4, 51-00-04	Detection of Water in Honeycomb

4. Repair Instructions

- A. Get access to the damaged area. If you cannot get access to the part to do a damage inspection, remove it from the airplane to do the inspection.
- B. Remove the Actuator Fitting Assembly from the APU Air Inlet Door assembly.
- C. Visually examine the acoustic liner, the acoustic core, and the bonded parts. Look for disbonds, punctures, dents, broken surfaces, scratches, contour defects, or other signs of damage.
- D. Do a Tap Test Inspection to examine the door for damage between the acoustic liner and the acoustic core. Refer to NDT Part 1, 51-05-01.
- E. Examine the part for contamination by water, oil, or dirt. If you think that there is water damage, do an ultrasonic inspection. Refer to NDT Part 4, 51-00-04. For water removal instructions, refer to GRAPHITE AND/OR ARAMID REINFORCED EPOXY LAMINATES AND NONMETALLIC HONEYCOMB SANDWICH REPAIRS - ROOM TEMPERATURE/150°F (66°C) CURE (WET LAYUP) , 51-70-03. If you cannot remove the contamination, cut out the contamination when you remove the damaged section.

STRUCTURAL REPAIR MANUAL

- F. Remove the damaged section of the acoustic liner. Make the trim the minimum dimensions possible. For damage between 0.5 in. (12.7 mm) and 1.0 in. (25.4 mm) in diameter, make a circular trim. For damage between 1.0 in. (25.4 mm) and 3.0 in. (76.2 mm) in diameter, make the trim a smooth shape with a minimum corner trim radius of 0.5 in. (12.7 mm). Sand the area of the trim to remove sharp edges.

NOTE: Do not cause damage to the adjacent structure. Do not cut into the acoustic core below the acoustic liner.

- G. Make sure that the edge of the acoustic liner around the trim line is bonded to the acoustic core. Do a Tap Test Inspection to examine the trim line. Refer to NDT Part 1, 51-05-01. If there is a disbond, remove the disbonded section of the acoustic liner. If the total quantity of damage removed is larger than 3.0 in. (76.2 mm) in diameter, do not use this repair.
- H. Make the repair parts. See Table 201/REPAIR 1 and Figure 201/REPAIR 1. The reinforcement fiberglass ply must extend a minimum of 1 in. (25 mm) more than the repair liner in all directions.
- I. Clean the repair area. Refer to REPAIRS TO 250°F (121°C) AND 350°F (177°C) CURED GRAPHITE/ARAMID/FIBERGLASS REINFORCED EPOXY LAMINATES AND NONMETALLIC HONEYCOMB SANDWICH STRUCTURE - 200°F (93°C) TO 230°F (110°C) WET LAYUP REPAIR METHOD, 51-70-17.

NOTE: Be careful to keep the repair surfaces clean. Do not touch the surfaces. Apply the adhesives immediately after you prepare the bonding surface.

- J. Prepare the potting resin BMS 8-301, Class I Grade I with fumed silica. Refer to Resin Mix 3 in Figure I of REPAIRS TO 250°F (121°C) AND 350°F (177°C) CURED GRAPHITE/ARAMID/FIBERGLASS REINFORCED EPOXY LAMINATES AND NONMETALLIC HONEYCOMB SANDWICH STRUCTURE - 200°F (93°C) TO 230°F (110°C) WET LAYUP REPAIR METHOD, 51-70-17.
- K. Apply the potting resin to the bond surface of the acoustic core.
- L. Align the cells of the repair acoustic liner in the same direction as the initial liner. Fill the gap between the initial liner and the repair liner with the potting resin.

NOTE: Make sure that the repair liner is flush with the initial liner. A gap of 0.06 in. (1.52 mm) or less is allowed between the repair liner and the initial liner.

- M. Apply the potting resin to the bond surface of the felt metal repair liner and the initial acoustic liner.
- N. Align the reinforcement fiberglass ply on the felt metal repair liner. See Figure 201/REPAIR 1.
- O. The Boeing Company recommends that you bond the assembly in an autoclave at 200°F (93°C) for 240 minutes. Use BMS 8-301, Class I Grade I adhesive. For the autoclave pressure, refer to METAL-TO-METAL STRUCTURAL REPAIR ADHESIVE BOND PROCEDURES, 51-70-09. As an alternative, you can bond the repair with a vacuum bag. Refer to REPAIRS TO 250°F (121°C) AND 350°F (177°C) CURED GRAPHITE/ARAMID/FIBERGLASS REINFORCED EPOXY LAMINATES AND NONMETALLIC HONEYCOMB SANDWICH STRUCTURE - 200°F (93°C) TO 230°F (110°C) WET LAYUP REPAIR METHOD, 51-70-17 for the bagging procedure.
- P. Lightly sand the ply surface of the repair and edges to make a smooth finish. Do not cause damage to the fibers.
- Q. Examine the repair for damage. Refer to NDT Part 1, 51-01-01. Your inspection must include a minimum width of 2.0 in. (50.8 mm) around the area that you heated. If you used an autoclave to bond the repair, examine all surfaces of the APU inlet door.
- R. If you find damage, remove the repair. Do not cause damage to the adjacent structure. After you remove the repair, do the repair procedure again.



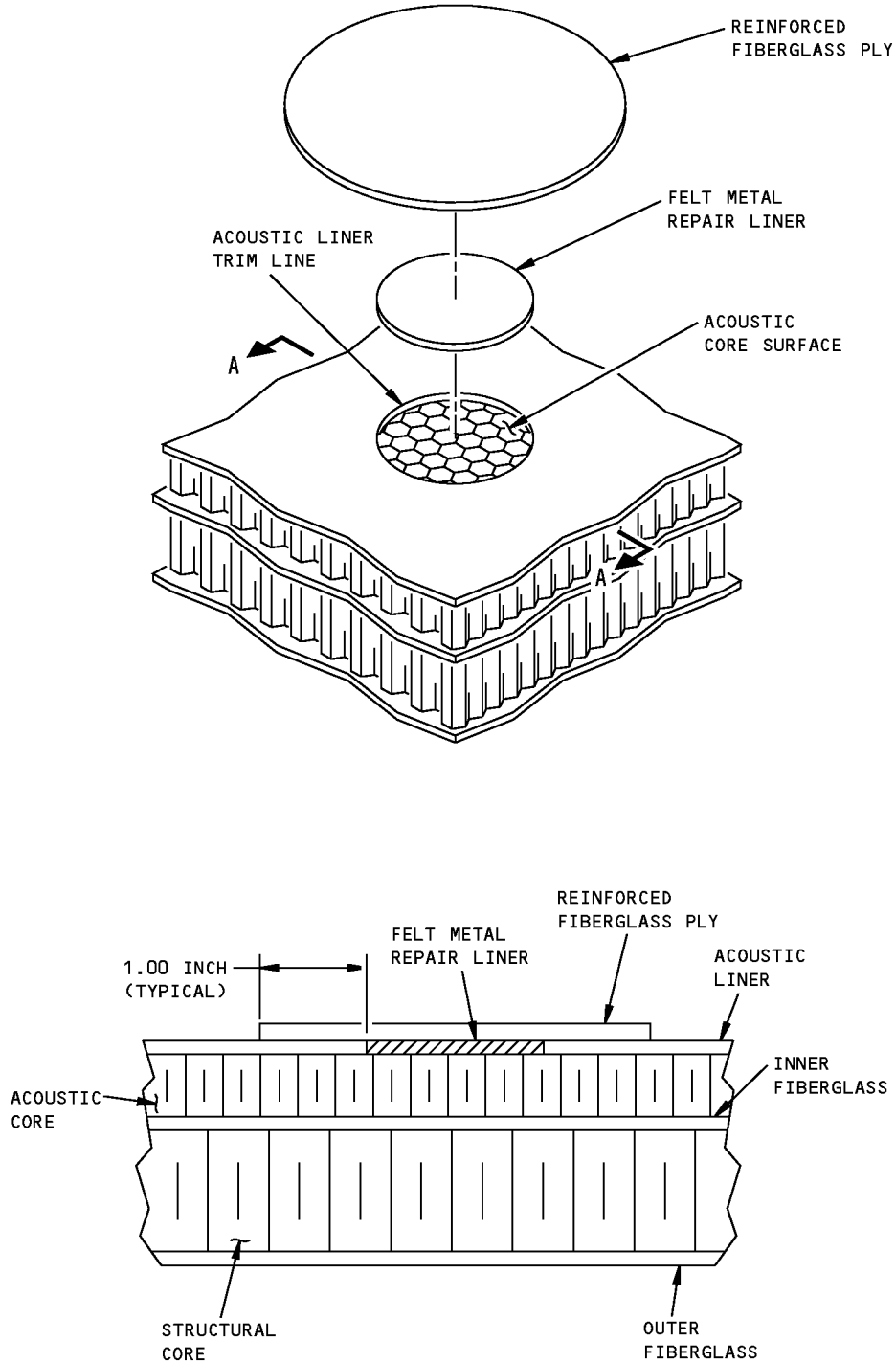
757-200
STRUCTURAL REPAIR MANUAL

- S. Examine the repair to make sure that there is no interference with the control surfaces. Examine the repair to make sure that there are sufficient clearances for all repaired parts.
- T. Replace the Actuator Fitting Assembly on the APU Air Inlet Door assembly.
- U. If you removed the door assembly from the airplane, replace the door assembly on the airplane.
- V. Replace the items removed for access.

Table 201: Repair Materials

PART		QTY	MATERIAL
1	FELT METAL REPAIR LINER	1	FELT METAL FM 1810
2	REINFORCEMENT FIBERGLASS PLY	1	BMS 9-3, TYPE 1581 OR 7781 COATED WITH BMS 8-301 CLASS 1 RESIN

**757-200
STRUCTURAL REPAIR MANUAL**



1543422 S0000281786_V1

**Acoustic Liner Damage Between 0.5 Inches and 3.0 Inches in Diameter
Figure 201**



757-200

STRUCTURAL REPAIR MANUAL

REPAIR 2 - ACOUSTIC LINER DAMAGE LARGER THAN 3.0 INCHES IN DIAMETER

1. Applicability

- A. This repair is applicable to damage to the acoustic liner of the air inlet door of the Auxiliary Power Unit (APU). The diameter of the damage must be more than 3.0 in. (76.2 mm).
- B. This repair is not applicable if you find damage on the adjacent acoustic core.
- C. This repair is not applicable if repairs other than Repair 2 have been done to the door assembly. If repairs other than Repair 2 have been done, contact The Boeing Company.
- D. You can use this repair on a maximum of one damage location on each door assembly. If there is more than one damage location, contact The Boeing Company.

2. General

CAUTION: DO NOT USE CHLORINATED SOLVENTS. DAMAGE TO THE CORE MATERIAL WILL OCCUR.

- A. Clean all parts before you inspect the damage.

3. References

Reference	Title
51-70-03	GRAPHITE AND/OR ARAMID REINFORCED EPOXY LAMINATES AND NONMETALLIC HONEYCOMB SANDWICH REPAIRS - ROOM TEMPERATURE/150°F (66°C) CURE (WET LAYUP)
51-70-09	METAL-TO-METAL STRUCTURAL REPAIR ADHESIVE BOND PROCEDURES
51-70-17	REPAIRS TO 250°F (121°C) AND 350°F (177°C) CURED GRAPHITE/ARAMID/FIBERGLASS REINFORCED EPOXY LAMINATES AND NONMETALLIC HONEYCOMB SANDWICH STRUCTURE - 200°F (93°C) TO 230°F (110°C) WET LAYUP REPAIR METHOD
51-70-17, GENERAL	Repairs to 250°F (121°C) and 350°F (177°C) Cured Graphite/Aramid/Fiberglass Reinforced Epoxy Laminates and Nonmetallic Honeycomb Sandwich Structure - 200°F (93°C) to 230°F (110°C) Wet Layup Repair Method
NDT Part 1, 51-01-01	Inspection of Repairs to Composite Structures
NDT Part 1, 51-05-01	Tap Test Inspection of Honeycomb Sandwich Structure
NDT Part 4, 51-00-04	Detection of Water in Honeycomb

4. Repair Instructions

- A. Get access to the damaged area. If you cannot get access to the part to do a damage inspection, remove it from the airplane to do the inspection.
- B. Remove the Actuator Fitting Assembly from the APU Air Inlet Door assembly.
- C. Visually examine the acoustic liner, the acoustic core, and the bonded parts. Look for disbonds, punctures, dents, broken surfaces, scratches, contour defects, or other signs of damage.
- D. Do a Tap Test Inspection to examine the door for damage between the acoustic liner and the acoustic core. Refer to NDT Part 1, 51-05-01.
- E. Examine the part for contamination by water, oil, or dirt. If you think that there is water damage, do an ultrasonic inspection. Refer to NDT Part 4, 51-00-04. For water removal instructions, refer to GRAPHITE AND/OR ARAMID REINFORCED EPOXY LAMINATES AND NONMETALLIC HONEYCOMB SANDWICH REPAIRS - ROOM TEMPERATURE/150°F (66°C) CURE (WET LAYUP) , 51-70-03. If you cannot remove the contamination, cut out the contamination when you remove the damaged section.

STRUCTURAL REPAIR MANUAL

- F. Remove the damaged section of the acoustic liner. Make the trim the minimum dimensions possible with rounded corners. The minimum radius for each corner is 0.5 in. (12.7 mm). Sand the area of the trim to remove sharp edges.

NOTE: Do not cause damage to the adjacent structure. Do not cut into the acoustic core below the acoustic liner.

- G. Make sure that the edge of the acoustic liner around the trim line is bonded to the acoustic core. Do a Tap Test Inspection to examine the trim line. Refer to NDT Part 1, 51-05-01. If there is a disbond, remove the disbanded section of the acoustic liner.

- H. Make the repair parts. See Table 201/REPAIR 2 and Figure 201/REPAIR 2. The fiberglass ply must overlap the repair liner and the initial liner by 0.5 in. (12.7 mm) along the trim line of the liner.

- I. Clean the repair area. Refer to REPAIRS TO 250°F (121°C) AND 350°F (177°C) CURED GRAPHITE/ARAMID/FIBERGLASS REINFORCED EPOXY LAMINATES AND NONMETALLIC HONEYCOMB SANDWICH STRUCTURE - 200°F (93°C) TO 230°F (110°C) WET LAYUP REPAIR METHOD, 51-70-17.

NOTE: Be careful to keep the repair surfaces clean. Do not touch the surfaces. Apply the adhesives immediately after you prepare the repair area.

- J. Apply FM-73U film adhesive to the acoustic core in a grid pattern. As an alternative, apply AF-163-2U film adhesive.

- K. Apply heat to the adhesive until it melts. Refer to the manufacturers instructions. After you melt the adhesive, it must have constant thickness across all cell wall edges. Make sure that the top surface of the acoustic core has a layer of adhesive.

NOTE: Do not apply adhesive directly to the acoustic liner.

- L. Align the cells of the repair acoustic liner in the same direction as the initial liner. Put the repair acoustic liner on the acoustic core.

NOTE: Do not move the repair acoustic liner after you put it on the acoustic core.

NOTE: Make sure that the repair liner is flush with the initial liner. A gap of 0.06 in. (1.52 mm) or less is allowed between the repair liner and the initial liner.

- M. Prepare the potting resin BMS 8-301, Class I Grade I with fumed silica. Refer to Resin Mix 3 in Figure I of REPAIRS TO 250°F (121°C) AND 350°F (177°C) CURED GRAPHITE/ARAMID/FIBERGLASS REINFORCED EPOXY LAMINATES AND NONMETALLIC HONEYCOMB SANDWICH STRUCTURE - 200°F (93°C) TO 230°F (110°C) WET LAYUP REPAIR METHOD, 51-70-17.

- N. Fill the gap between the initial liner and the repair liner with the potting resin.

- O. Apply the potting resin to the repair area of the felt metal repair liner and the initial acoustic liner.

- P. Align the reinforcement fiberglass ply on the felt metal repair liner. See Figure 201/REPAIR 2.

- Q. The Boeing Company recommends that you bond the assembly in an autoclave at 200°F (93°C) for 240 minutes. Use BMS 8-301, Class I Grade I adhesive. For the autoclave pressure, refer to METAL-TO-METAL STRUCTURAL REPAIR ADHESIVE BOND PROCEDURES, 51-70-09. As an alternative, you can bond the repair with a vacuum bag. Refer to REPAIRS TO 250°F (121°C) AND 350°F (177°C) CURED GRAPHITE/ARAMID/FIBERGLASS REINFORCED EPOXY LAMINATES AND NONMETALLIC HONEYCOMB SANDWICH STRUCTURE - 200°F (93°C) TO 230°F (110°C) WET LAYUP REPAIR METHOD, 51-70-17 for the bagging procedure.

- R. Lightly sand the ply surface of the repair and edges to make a smooth finish. Refer to 51-70-17, GENERAL.

NOTE: Do not cause damage to the fibers of the reinforcement fiberglass ply.



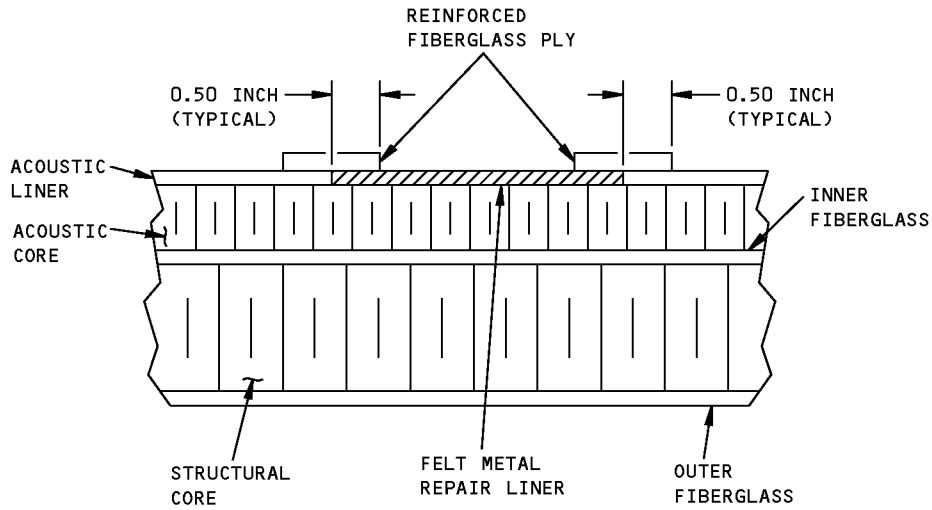
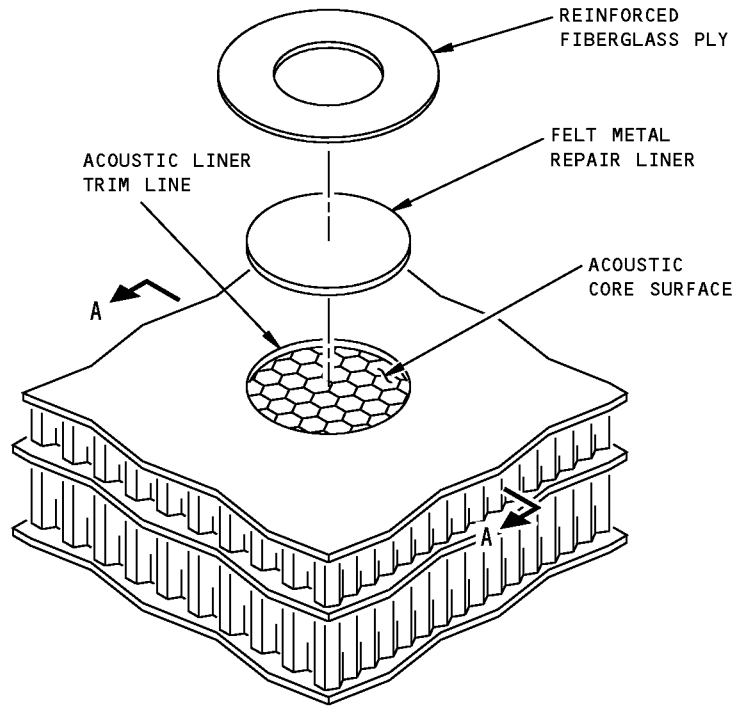
757-200
STRUCTURAL REPAIR MANUAL

- S. Examine the repair for damage. Refer to NDT Part 1, 51-01-01. Your inspection must include a minimum width of 2.0 in. (50.8 mm) around the area that you heated. If you used an autoclave to bond the repair, examine all surfaces of the APU inlet door.
- T. If you find damage, remove the repair. Do not cause damage to the adjacent structure. After you remove the repair, do the repair procedure again.
- U. Examine the repair to make sure that there is no interference with the control surfaces. Examine the repair to make sure that there are sufficient clearances for all repaired parts.
- V. Replace the Actuator Fitting Assembly on the APU Air Inlet Door assembly.
- W. If you removed the door assembly from the airplane, replace the door assembly on the airplane.
- X. Replace the items removed for access.

Table 201: Repair Materials

PART		QTY	MATERIAL
1	FELT METAL REPAIR LINER	1	FELT METAL FM 1810
2	REINFORCEMENT FIBERGLASS PLY	1	BMS 9-3, TYPE 1581 OR 7781 COATED WITH BMS 8-301 CLASS 1 RESIN

**757-200
STRUCTURAL REPAIR MANUAL**



SECTION A-A

1543427 S0000281807_V1

**Acoustic Liner Damage Larger Than 3.0 Inches in Diameter
Figure 201**



757-200

STRUCTURAL REPAIR MANUAL

REPAIR 3 - ACOUSTIC LINER AND ACOUSTIC CORE DAMAGE BETWEEN 0.5 INCHES AND 3.0 INCHES IN DIAMETER

1. Applicability

- A. This repair is applicable to damage to the acoustic liner and the acoustic core of the air inlet door of the Auxiliary Power Unit (APU). The diameter of the damage must be between 0.5 in. (12.7 mm) and 3.0 in. (76.2 mm).
- B. This repair is not applicable if repairs other than Repair 3 have been done to the door assembly. If repairs other than Repair 3 have been done, contact The Boeing Company.
- C. You can use this repair on a maximum of two damage locations on each door assembly. The edge distance between damage locations must be a minimum of four times the diameter of the largest disbond.

2. General

CAUTION: DO NOT USE CHLORINATED SOLVENTS. DAMAGE TO THE CORE MATERIAL WILL OCCUR.

- A. Clean all parts before you inspect the damage.

3. References

Reference	Title
51-70-03	GRAPHITE AND/OR ARAMID REINFORCED EPOXY LAMINATES AND NONMETALLIC HONEYCOMB SANDWICH REPAIRS - ROOM TEMPERATURE/150°F (66°C) CURE (WET LAYUP)
51-70-09	METAL-TO-METAL STRUCTURAL REPAIR ADHESIVE BOND PROCEDURES
51-70-17	REPAIRS TO 250°F (121°C) AND 350°F (177°C) CURED GRAPHITE/ARAMID/FIBERGLASS REINFORCED EPOXY LAMINATES AND NONMETALLIC HONEYCOMB SANDWICH STRUCTURE - 200°F (93°C) TO 230°F (110°C) WET LAYUP REPAIR METHOD
51-70-17, GENERAL	Repairs to 250°F (121°C) and 350°F (177°C) Cured Graphite/Aramid/Fiberglass Reinforced Epoxy Laminates and Nonmetallic Honeycomb Sandwich Structure - 200°F (93°C) to 230°F (110°C) Wet Layup Repair Method
NDT Part 1, 51-01-01	Inspection of Repairs to Composite Structures
NDT Part 1, 51-05-01	Tap Test Inspection of Honeycomb Sandwich Structure
NDT Part 4, 51-00-04	Detection of Water in Honeycomb

4. Repair Instructions

- A. Get access to the damaged area. If you cannot get access to the part to do a damage inspection, remove it from the airplane to do the inspection.
- B. Remove the Actuator Fitting Assembly from the APU Air Inlet Door assembly.
- C. Visually examine the acoustic liner, the acoustic core, and the bonded parts. Look for disbonds, punctures, dents, broken surfaces, scratches, contour defects, or other signs of damage.
- D. Do a Tap Test Inspection to examine the door for damage between the acoustic liner and the acoustic core. Refer to NDT Part 1, 51-05-01.



757-200

STRUCTURAL REPAIR MANUAL

- E. Examine the part for contamination by water, oil, or dirt. If you think that there is water damage, do an ultrasonic inspection. Refer to NDT Part 4, 51-00-04. For water removal instructions, refer to GRAPHITE AND/OR ARAMID REINFORCED EPOXY LAMINATES AND NONMETALLIC HONEYCOMB SANDWICH REPAIRS - ROOM TEMPERATURE/150°F (66°C) CURE (WET LAYUP) , 51-70-03. If you cannot remove the contamination, cut out the contamination when you remove the damaged section.
- F. Remove the damaged section of the acoustic liner. Remove the damaged section of the acoustic core. The trim line of the acoustic liner must be a minimum of 0.50 in. (12.70 mm) more than the trim line of the acoustic core. See Figure 201/REPAIR 3. Make the trim the minimum dimensions possible with rounded corners. For damage between 0.5 in. (12.7 mm) and 1.0 in. (25.4 mm) in diameter, make a circular trim. For damage between 1.0 in. (25.4 mm) and 3.0 in. (76.2 mm) in diameter, make the trim a smooth shape with a minimum corner trim radius of 0.5 in. (12.7 mm). Sand the area of the trim to remove sharp edges.
- NOTE:** Do not cause damage to the adjacent structure.
- NOTE:** Do not cause damage to the acoustic core when you cut the acoustic liner.
- NOTE:** Do not cause damage to the inner structural fiberglass when you cut the acoustic core.
- G. Make sure that the edge of the acoustic liner around the trim line is bonded to the acoustic core. Do a Tap Test Inspection to examine the trim line. Refer to NDT Part 1, 51-05-01. If there is a disbond, remove the disbonded section of the acoustic liner. If the total quantity of damage removed is larger than 3.0 in. (76.2 mm) in diameter, do not use this repair.
- H. Make the repair parts. See Table 201/REPAIR 3 and Figure 201/REPAIR 3. The acoustic replacement core must have the same dimensions and orientation as the removed core. The reinforcement fiberglass ply must extend a minimum of 1.0 in. (25.4 mm) more than the repair liner in all directions.
- I. Clean the repair area. Refer to REPAIRS TO 250°F (121°C) AND 350°F (177°C) CURED GRAPHITE/ARAMID/FIBERGLASS REINFORCED EPOXY LAMINATES AND NONMETALLIC HONEYCOMB SANDWICH STRUCTURE - 200°F (93°C) TO 230°F (110°C) WET LAYUP REPAIR METHOD, 51-70-17.
- NOTE:** Be careful to keep the repair surfaces clean. Do not touch the surfaces. Apply the adhesives immediately after you prepare the repair area.
- J. Prepare the potting resin BMS 8-301, Class I Grade I with fumed silica. Refer to Resin Mix 3 in Figure I of REPAIRS TO 250°F (121°C) AND 350°F (177°C) CURED GRAPHITE/ARAMID/FIBERGLASS REINFORCED EPOXY LAMINATES AND NONMETALLIC HONEYCOMB SANDWICH STRUCTURE - 200°F (93°C) TO 230°F (110°C) WET LAYUP REPAIR METHOD, 51-70-17.
- K. Apply the potting resin to the repair surface of the inner fiberglass.
- L. Align the cells of the repair acoustic core in the same direction as the initial core. Fill the gap between the initial core and the repair core with the potting resin.
- M. Apply the potting resin to the repair area of the acoustic liner.
- N. Align the cells of the repair acoustic liner in the same direction as the initial liner. Fill the gap between the initial liner and the repair liner with the potting resin.
- NOTE:** Make sure that the repair liner is flush with the initial liner. A gap of 0.06 in. (1.52 mm) or less is allowed between the repair liner and the initial liner.
- O. Apply the potting resin to the repair area of the felt metal repair liner and the initial acoustic liner.
- P. Align the reinforcement fiberglass ply on the felt metal repair liner. See Figure 201/REPAIR 3.



757-200

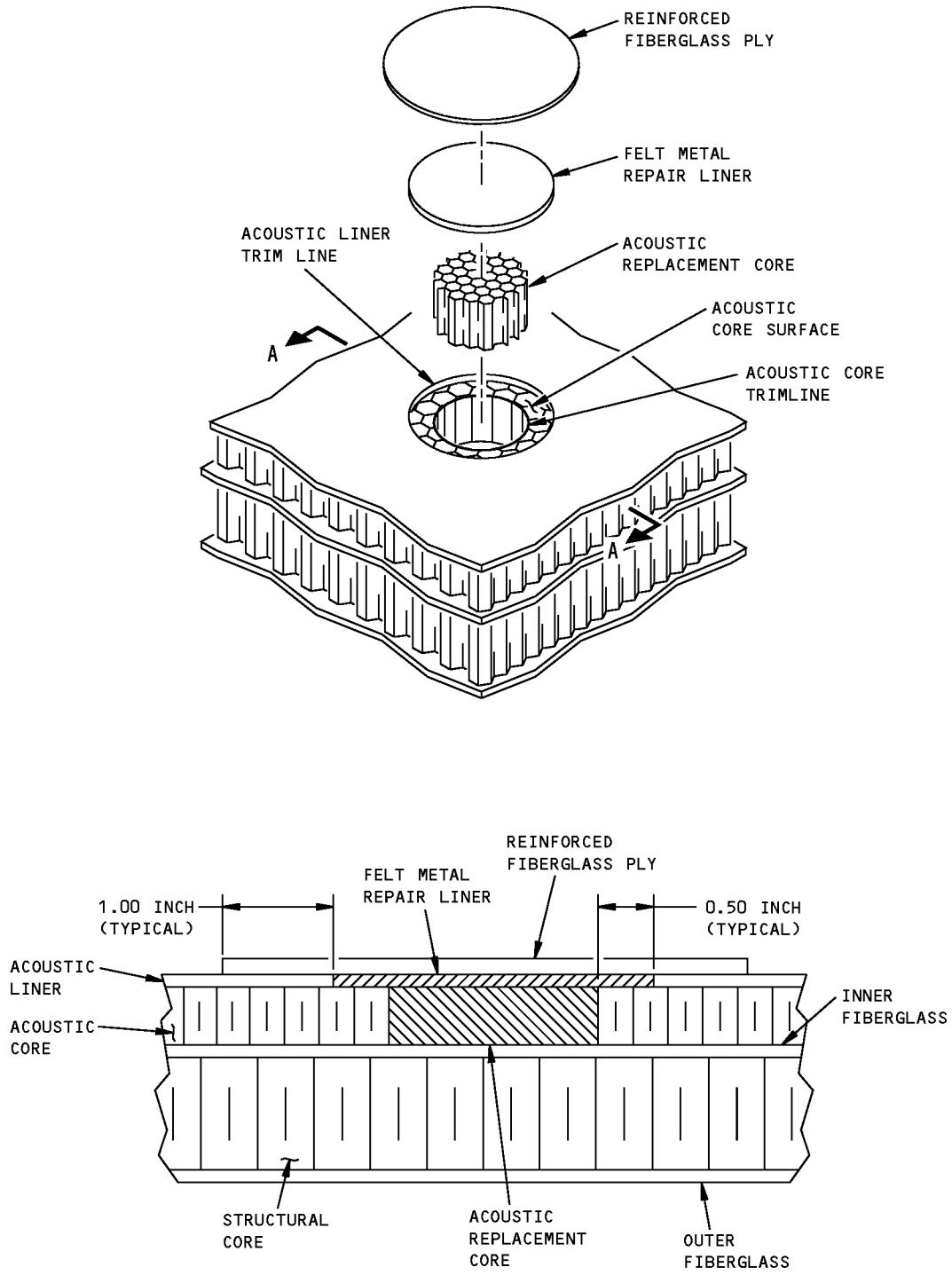
STRUCTURAL REPAIR MANUAL

- Q. The Boeing Company recommends that you bond the assembly in an autoclave at 200°F (93°C) for 240 minutes. Use BMS 8-301, Class I Grade I adhesive. For the autoclave pressure, refer to METAL-TO-METAL STRUCTURAL REPAIR ADHESIVE BOND PROCEDURES, 51-70-09. As an alternative, you can bond the repair with a vacuum bag. Refer to REPAIRS TO 250°F (121°C) AND 350°F (177°C) CURED GRAPHITE/ARAMID/FIBERGLASS REINFORCED EPOXY LAMINATES AND NONMETALLIC HONEYCOMB SANDWICH STRUCTURE - 200°F (93°C) TO 230°F (110°C) WET LAYUP REPAIR METHOD, 51-70-17 for the bagging procedure.
- R. Lightly sand the ply surface of the repair and edges to make a smooth finish. Refer to 51-70-17, GENERAL.
- NOTE:** Do not cause damage to the fibers of the reinforcement fiberglass ply.
- S. Examine the repair for damage. Refer to NDT Part 1, 51-01-01. Your inspection must include a minimum width of 2.0 in. (50.8 mm) around the area that you heated. If you used an autoclave to bond the repair, examine all surfaces of the APU inlet door.
- T. If you find damage, remove the repair. Do not cause damage to the adjacent structure. After you remove the repair, do the repair procedure again.
- U. Examine the repair to make sure that there is no interference with the control surfaces. Examine the repair to make sure that there are sufficient clearances for all repaired parts.
- V. Replace the Actuator Fitting Assembly on the APU Air Inlet Door assembly.
- W. If you removed the door assembly from the airplane, replace the door assembly on the airplane.
- X. Replace the items removed for access.

Table 201: Repair Materials

PART		QTY	MATERIAL
1	FELT METAL REPAIR LINER	1	FELT METAL FM 1810
2	REINFORCEMENT FIBERGLASS PLY	1	BMS 9-3, TYPE 1581 OR 7781 COATED WITH BMS 8-301 CLASS 1 RESIN
3	ACOUSTIC REPLACEMENT CORE	1	BMS 8-124, CLASS 1, TYPE III, GRADE 3.5

**757-200
STRUCTURAL REPAIR MANUAL**



SECTION A-A

1543525 S0000281854_V1

**Acoustic Liner and Acoustic Core Damage Between 0.5 Inches and 3.0 Inches in Diameter
Figure 201**



757-200

STRUCTURAL REPAIR MANUAL

REPAIR 4 - ACOUSTIC LINER OR ACOUSTIC CORE DAMAGE LESS THAN 0.5 INCHES IN DIAMETER

1. Applicability

- A. This repair is applicable to damage to the acoustic liner or the acoustic core of the air inlet door of the Auxiliary Power Unit (APU). The diameter of the damage must be less than 0.5 in. (12.7 mm).
- B. This repair is not applicable if repairs other than Repair 4 have been done to the door assembly. If repairs other than Repair 4 have been done, contact The Boeing Company.
- C. You can use this repair on a maximum of four damage locations on each door assembly. The edge distance between damage locations must be a minimum of four times the diameter of the largest disbond.

2. General

CAUTION: DO NOT USE CHLORINATED SOLVENTS. DAMAGE TO THE CORE MATERIAL WILL OCCUR.

- A. Clean all parts before you inspect the damage.

3. References

Reference	Title
51-70-03	GRAPHITE AND/OR ARAMID REINFORCED EPOXY LAMINATES AND NONMETALLIC HONEYCOMB SANDWICH REPAIRS - ROOM TEMPERATURE/150°F (66°C) CURE (WET LAYUP)
51-70-17	REPAIRS TO 250°F (121°C) AND 350°F (177°C) CURED GRAPHITE/ARAMID/FIBERGLASS REINFORCED EPOXY LAMINATES AND NONMETALLIC HONEYCOMB SANDWICH STRUCTURE - 200°F (93°C) TO 230°F (110°C) WET LAYUP REPAIR METHOD
51-70-17, GENERAL	Repairs to 250°F (121°C) and 350°F (177°C) Cured Graphite/Aramid/Fiberglass Reinforced Epoxy Laminates and Nonmetallic Honeycomb Sandwich Structure - 200°F (93°C) to 230°F (110°C) Wet Layup Repair Method
NDT Part 1, 51-01-01	Inspection of Repairs to Composite Structures
NDT Part 1, 51-05-01	Tap Test Inspection of Honeycomb Sandwich Structure
NDT Part 4, 51-00-04	Detection of Water in Honeycomb

4. Repair Instructions

- A. Get access to the damaged area. If you cannot get access to the part to do a damage inspection, remove it from the airplane to do the inspection.
- B. Remove the Actuator Fitting Assembly from the APU Air Inlet Door assembly.
- C. Visually examine the acoustic liner, the acoustic core, and the bonded parts. Look for disbonds, punctures, dents, broken surfaces, scratches, contour defects, or other signs of damage.
- D. Do a Tap Test Inspection to examine the door for damage between the acoustic liner and the acoustic core. Refer to NDT Part 1, 51-05-01.
- E. Examine the part for contamination by water, oil, or dirt. If you think that there is water damage, do an ultrasonic inspection. Refer to NDT Part 4, 51-00-04. For water removal instructions, refer to GRAPHITE AND/OR ARAMID REINFORCED EPOXY LAMINATES AND NONMETALLIC HONEYCOMB SANDWICH REPAIRS - ROOM TEMPERATURE/150°F (66°C) CURE (WET LAYUP) , 51-70-03. If you cannot remove the contamination, cut out the contamination when you remove the damaged section.

STRUCTURAL REPAIR MANUAL

- F. Remove the damaged section of the acoustic liner. Remove the acoustic core from below the acoustic liner. The trim line of the acoustic core must be a minimum of 0.25 in. (6.4 mm) more than the trim line of the acoustic liner. If the acoustic core is damaged, this cut must remove all of the damaged acoustic core. See Figure 201/REPAIR 4. Make a circular trim with the minimum dimensions possible. Sand the area of the trim to remove sharp edges.

NOTE: Do not cause damage to the adjacent structure.

NOTE: Do not cause damage to the acoustic core when you cut the acoustic liner.

NOTE: Do not cause damage to the inner structural fiberglass when you cut the acoustic core.

- G. Make sure that the edge of the acoustic liner around the trim line of the acoustic core is bonded to the acoustic core. Do a Tap Test Inspection to examine the trim line. Refer to NDT Part 1, 51-05-01. If there is a disbond, remove the disbonded section of the acoustic core. If the total quantity of damage removed is larger than 0.5 in. (12.7 mm) in diameter, do not use this repair.
- H. Clean the repair area. Refer to REPAIRS TO 250°F (121°C) AND 350°F (177°C) CURED GRAPHITE/ARAMID/FIBERGLASS REINFORCED EPOXY LAMINATES AND NONMETALLIC HONEYCOMB SANDWICH STRUCTURE - 200°F (93°C) TO 230°F (110°C) WET LAYUP REPAIR METHOD, 51-70-17.

NOTE: Be careful to keep the repair surfaces clean. Do not touch the surfaces. Apply the adhesives immediately after you prepare the repair surface.

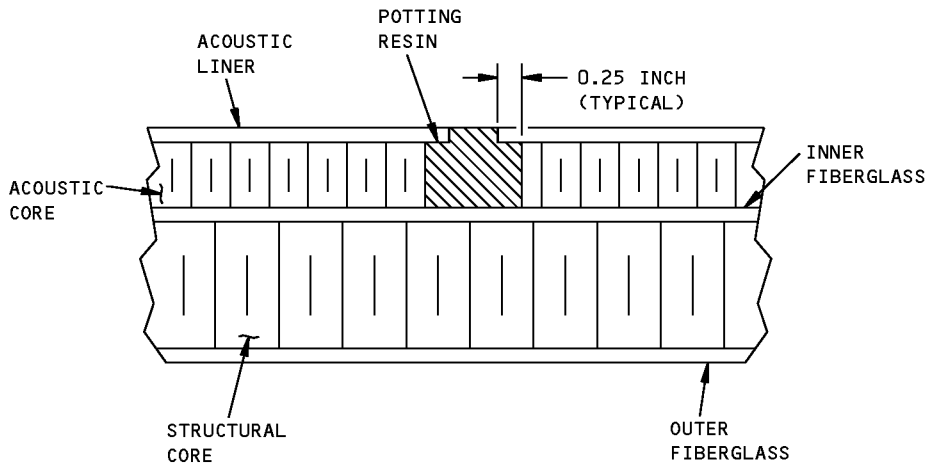
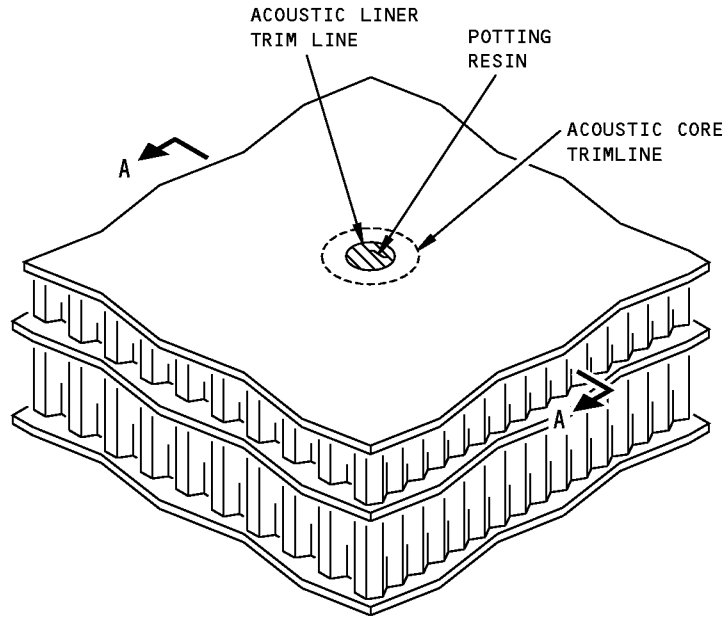
- I. Prepare the potting resin BMS 8-301, Class I Grade I with fumed silica. Refer to Resin Mix 3 in Figure I of REPAIRS TO 250°F (121°C) AND 350°F (177°C) CURED GRAPHITE/ARAMID/FIBERGLASS REINFORCED EPOXY LAMINATES AND NONMETALLIC HONEYCOMB SANDWICH STRUCTURE - 200°F (93°C) TO 230°F (110°C) WET LAYUP REPAIR METHOD, 51-70-17.
- J. Apply the potting resin to the repair location. The height of the resin must be more than the height of the surface of the acoustic liner.
- K. Cure the assembly. Refer to Paragraph 3G of 51-70-17, GENERAL.
- L. Lightly sand the surface of the potting resin to make a smooth finish. The repair surface must be flush to the acoustic liner with a tolerance of 0.010 in. (0.254 mm).

NOTE: Do not sand the surface of the acoustic liner.

NOTE: You can use a 0.010 in. (0.254 mm) thick aluminum template to prevent damage to the surface of the acoustic liner when you are sanding.

- M. Examine the repair for damage. Refer to NDT Part 1, 51-01-01. Your inspection must include a minimum width of 2.0 in. (50.8 mm) around the area that you heated. If you used an autoclave to bond the repair, examine all surfaces of the APU inlet door.
- N. If you find damage, remove the repair. Do not cause damage to the adjacent structure. After you remove the repair, do the repair procedure again.
- O. Examine the repair to make sure that there is no interference with the control surfaces. Examine the repair to make sure that there are sufficient clearances for all repaired parts.
- P. Replace the Actuator Fitting Assembly on the APU Air Inlet Door assembly.
- Q. If you removed the door assembly from the airplane, replace the door assembly on the airplane.
- R. Replace the items removed for access.

**757-200
STRUCTURAL REPAIR MANUAL**



SECTION A-A

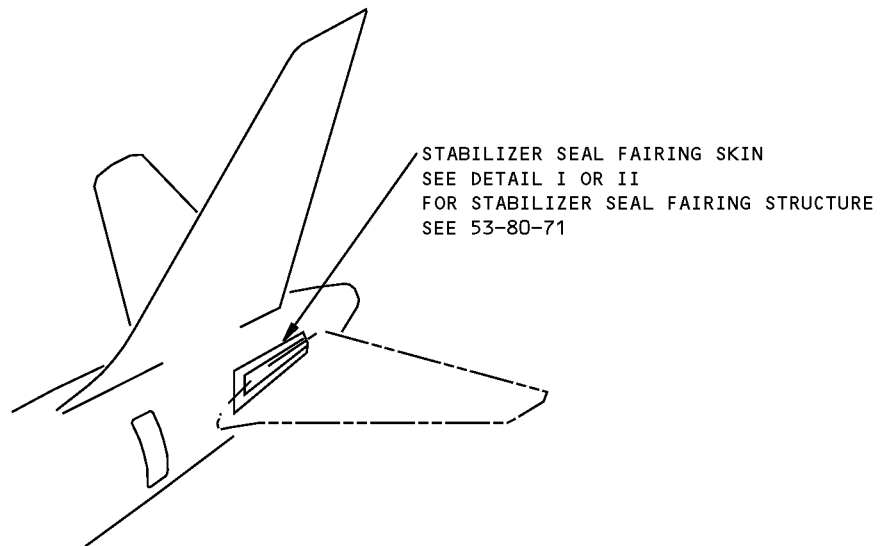
1543526 S0000281855_V1

**Acoustic Liner or Acoustic Core Damage Less Than 0.5 Inches in Diameter
Figure 201**



757-200
STRUCTURAL REPAIR MANUAL

IDENTIFICATION 1 - SECTION 48 - SEAL FAIRING SKIN

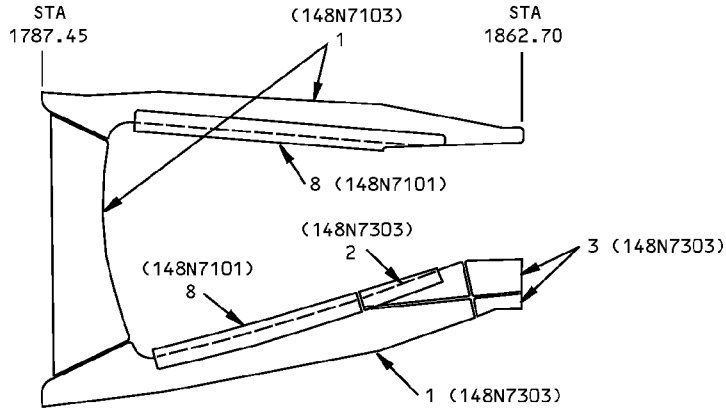


NOTES

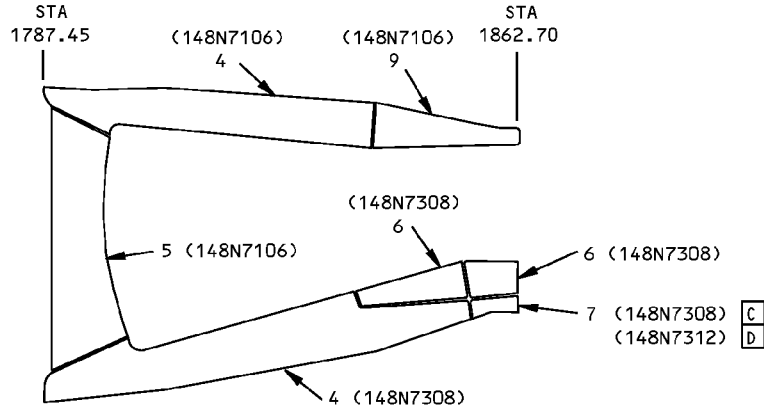
- A** FOR CUM LINE NUMBERS:
1 THRU 3
- B** FOR ALL AIRPLANES NOT IN **A**
- C** FOR CUM LINE NUMBERS:
7,8,10,11
- D** FOR CUM LINE NUMBERS:
4 THRU 6,9,12 AND ON

Section 48 Seal Fairing Skin Identification
Figure 1 (Sheet 1 of 2)

**757-200
STRUCTURAL REPAIR MANUAL**



**SEAL FAIRING SKIN
(CUM LINE NUMBERS 1 THRU 3)
DETAIL I**



**SEAL FAIRING SKIN
(CUM LINE NUMBERS 4 AND ON)
DETAIL II**

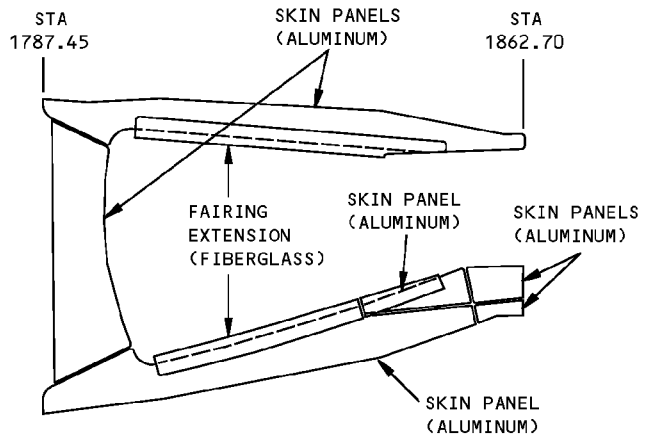
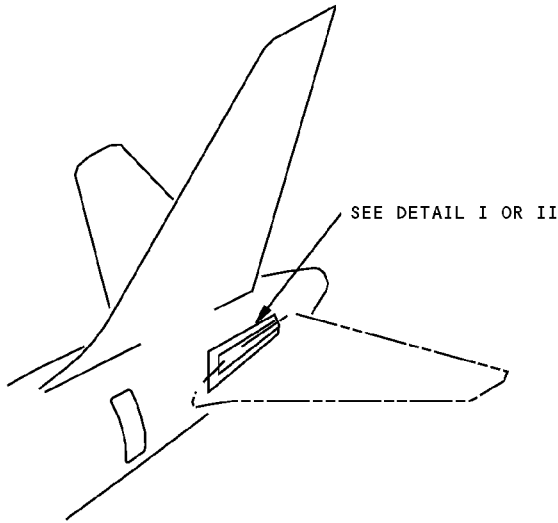
ITEM	DESCRIPTION	GAGE	MATERIAL	EFFECTIVITY
1	SKIN PANEL	0.080	CLAD 7075-T6 (CHEM-MILLED TO 0.038 MIN)	A
2	SKIN PANEL	0.056	CLAD 7075-T6	A
3	SKIN PANEL	0.080	CLAD 7075-T6 (CHEM-MILLED TO 0.056 MIN)	A
4	SKIN PANEL	0.071	CLAD 2024-T42 (CHEM-MILLED TO 0.038 MIN)	B
5	SKIN PANEL	0.080	CLAD 2024-T42 (CHEM-MILLED TO 0.038 MIN)	B
6	SKIN PANEL	0.071	CLAD 2024-T42 (CHEM-MILLED TO 0.050 MIN)	B
7	SKIN PANEL	0.090 0.095	CLAD 2024-T42 FIBERGLASS EPOXY LAMINATE PER BMS 8-79 TYPE 1581, CLASS III, GRADE 1 OPTIONAL: TYPE 7781 OR 120 TO MEET THICKNESS REQUIREMENTS	C D
8	FAIRING EXTENSION	0.071	CLAD 2024-T42	A
9	SKIN PANEL	0.090	CLAD 2024-T42 (CHEM-MILLED TO 0.038 MIN)	B

LIST OF MATERIALS FOR DETAILS I AND II

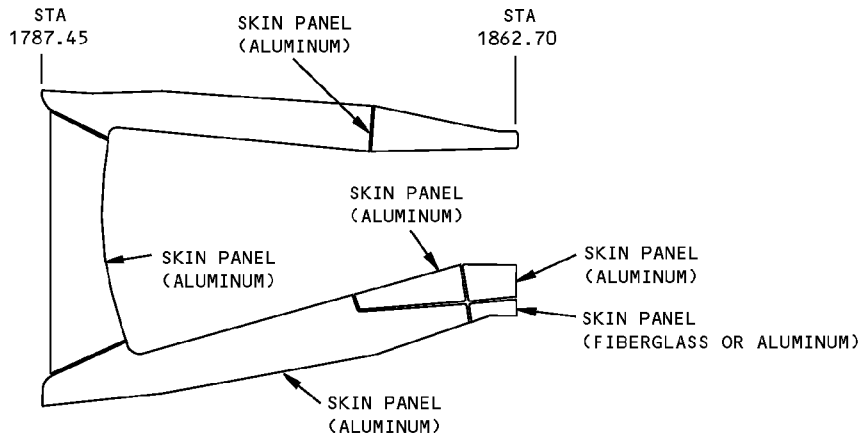
**Section 48 Seal Fairing Skin Identification
Figure 1 (Sheet 2 of 2)**

**757-200
STRUCTURAL REPAIR MANUAL**

ALLOWABLE DAMAGE 1 - SECTION 48 - SEAL FAIRING SKIN



**SEAL FAIRING SKIN
(CUM LINE NUMBERS 1 THRU 3)
DETAIL I**



**SEAL FAIRING SKIN
(CUM LINE NUMBERS 4 AND ON)
DETAIL II**

**Section 48 Seal Fairing Skin Allowable Damage
Figure 101 (Sheet 1 of 4)**

STRUCTURAL REPAIR MANUAL

DESCRIPTION	CRACKS	NICKS, GOUGES AND CORROSION	DENTS	HOLES AND PUNCTURES	PANEL DELAMINA- TION	EDGE EROSION
SKIN PANEL (ALUMINUM)	[B]	[C]	SEE DETAIL III	[D]	--	--
SKIN PANEL (FIBER- GLASS)	[E]	[F]	[G]	[H]	[I]	SEE DETAIL VIII
FAIRING EXTENSION (FIBERGLASS)	[E]	[F]	[G]	[H]	[I]	SEE DETAIL VIII

NOTES

- REFINISH REWORKED AREAS AS SHOWN IN SRM 51-20
- REFER TO SRM 51-10-01 FOR AERODYNAMIC SMOOTHNESS REQUIREMENTS. WHERE THE DAMAGE IS MORE THAN THE LIMITS SHOWN IN SRM 51-10-01, CONSIDERATION SHOULD BE GIVEN TO THE LOSS OF PERFORMANCE INVOLVED
- REFER TO SRM 51-10-02 FOR INSPECTION AND REMOVAL OF DAMAGE

[A] REMOVE MOISTURE FROM DAMAGE AREA. USE OF VACUUM AND HEAT (MAX 125°F (52°C)) TO REMOVE MOISTURE FROM HONEYCOMB CELLS IS RECOMMENDED. PROTECT DAMAGE FROM ENTRANCE OF WATER, SUNLIGHT OR OTHER FOREIGN MATTER BY SEALING WITH ALUMINUM FOIL TAPE (SPEED TAPE). RECORD LOCATION AND INSPECT AT AIRPLANE "A" CHECK. REPLACE ALUMINUM FOIL IF ANY PEELING OR DETERIORATION OF TAPE IS EVIDENT. REPAIR DAMAGE AS SHOWN IN SRM 51-70 NO LATER THAN THE NEXT "C" CHECK.

[B] 0.50 INCH (12.7 mm) MAX LENGTH PERMITTED PROVIDED CRACK IS MIN 1.00 (25 mm) FROM PANEL EDGE OR ADJACENT DAMAGE. 0.50 INCH (12.7 mm) CRACK ENDING AT FASTENER LOCATIONS IS PERMITTED. DRILL 0.19 INCH (4.8 mm) DIA STOP HOLES AT ENDS OF CRACK. REMOVE EDGE CRACKS AS SHOWN IN DETAIL III.

[C] REMOVE DAMAGE AS SHOWN IN DETAILS V, VI, AND VIII

[D] CLEAN OUT DAMAGE UP TO 0.50 INCH (12.7 mm) MAX DIA AND NOT CLOSER THAN 1.0 INCH (25 mm) TO FASTENER HOLE, MATERIAL EDGE, OR OTHER DAMAGE. ALL OTHER HOLES TO BE REPAIRED

[E] 1.0 INCH (25 mm) MAX LENGTH AND A MINIMUM OF 3.0 INCHES (75 mm) (EDGE TO EDGE) FROM ANY OTHER CRACK PROVIDED DAMAGE DOES NOT INTERFERE WITH ANY MOVING SURFACES AND DOES NOT EXCEED 10% OF EDGE BAND FOR EACH SIDE. CRACK THRU ONE FASTENER HOLE IN SIX IS PERMITTED. CLEAN UP EDGE CRACKS AS SHOWN IN DETAILS III AND VII. [A]

[F] 2.0 INCHES (50 mm) MAX LENGTH PERMITTED AND A MINIMUM OF 3.0 INCHES (75 mm) FROM OTHER DAMAGE PROVIDED DAMAGE DOES NOT INTERFERE WITH MOVING SURFACES, AND DOES NOT EXCEED 10% OF EDGE BAND LENGTH PER SIDE. CLEAN UP EDGE DAMAGE AS SHOWN IN DETAILS III AND VII. [A]

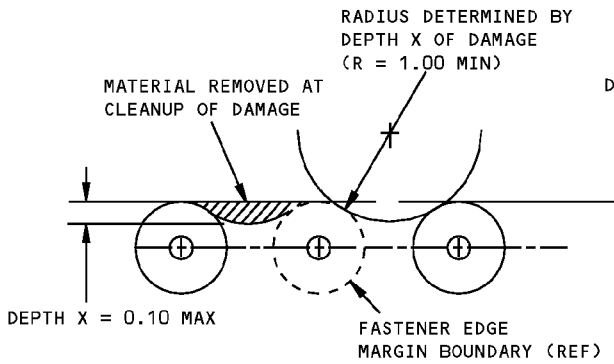
[G] DENTS GENERALLY RESULT IN FIBER DAMAGE OR DELAMINATION. HOWEVER, IF THERE IS NO FIBER DAMAGE OR DELAMINATION, DENTS UP TO 2.0 INCHES (50 mm) DIA MAX ARE PERMITTED. ONE DENT FOR EACH 6 X 6 INCHES (150 X 150 mm) OF AREA PERMITTED WHICH MUST BE A MINIMUM OF 3 INCHES (75 mm) FROM ANY OTHER DAMAGE, FASTENER HOLE, OR PANEL EDGE. SEE [H] OR [I] IF FIBER DAMAGE OR DELAMINATION IS PRESENT.

[H] 1.0 INCH (25 mm) MAX DIMENSION (D) IS PERMITTED FOR EACH 6 X 6 INCHES (150 X 150 mm) OF AREA AND A MINIMUM OF 6D (EDGE TO EDGE) FROM ANY OTHER DAMAGE, FASTENER HOLE OR PANEL EDGE. DO NOT CLEAN UP DAMAGE EXCEPT TO REMOVE RESIN BURRS EXTENDING INTO SURFACE CONTOUR. [A]

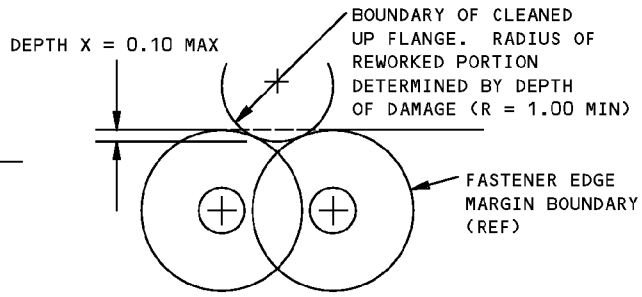
[I] 1.0 INCH (25 mm) MAX DIMENSION (D) IS PERMITTED FOR EACH 6 X 6 INCHES (150 X 150 mm) OF AREA AND A MINIMUM OF 6 D (EDGE TO EDGE) FROM ANY OTHER DAMAGE, FASTENER HOLE OR PANEL EDGE. A MAXIMUM OF 0.10 DELAMINATION FROM EDGE IS PERMITTED. PROTECT EDGE DAMAGE AS SHOWN IN [A]. REPAIR DELAMINATION AS SHOWN IN SRM 51-70 NO LATER THAN NEXT "C" CHECK.

**Section 48 Seal Fairing Skin Allowable Damage
Figure 101 (Sheet 2 of 4)**

**757-200
STRUCTURAL REPAIR MANUAL**

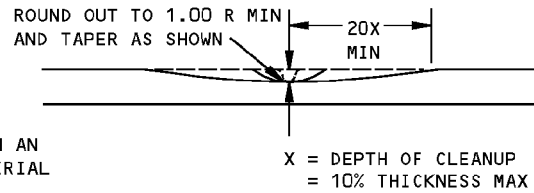
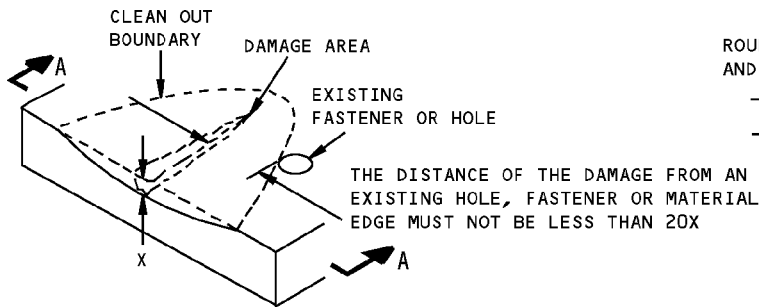


DAMAGE CLEANUP OF EDGES WHERE FASTENER EDGE MARGINS DO NOT OVERLAP



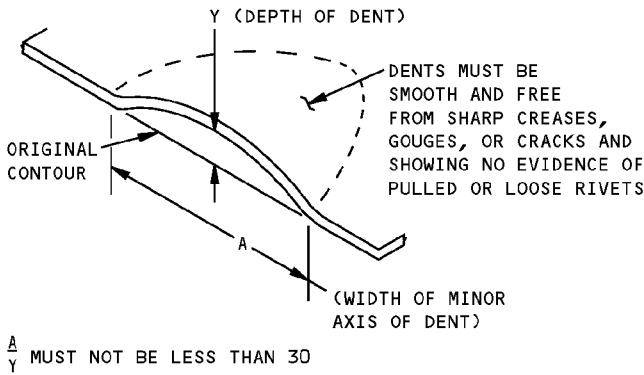
DAMAGE CLEANUP OF EDGES WHERE FASTENER EDGE MARGINS OVERLAP

DETAIL III

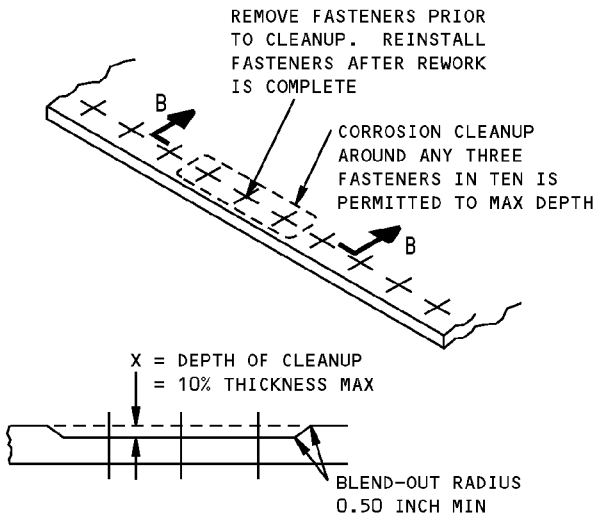


SECTION A-A

**REMOVAL OF NICK, GOUGE AND SCRATCH DAMAGE ON A SURFACE
DETAIL IV**



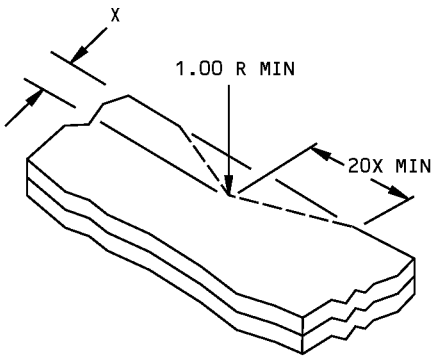
**ALLOWABLE DAMAGE FOR DENT
DETAIL V**



**SECTION B-B
CORROSION CLEANUP
DETAIL VI**

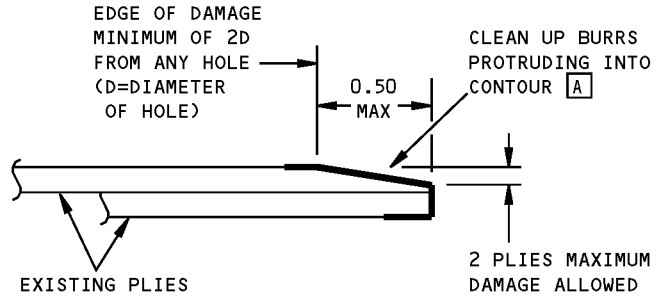
**Section 48 Seal Fairing Skin Allowable Damage
Figure 101 (Sheet 3 of 4)**

**757-200
STRUCTURAL REPAIR MANUAL**



X = DEPTH OF CLEANUP = 0.10 MAX

**REMOVAL OF NICK OR CRACK
DAMAGE ON AN EDGE
DETAIL VII**

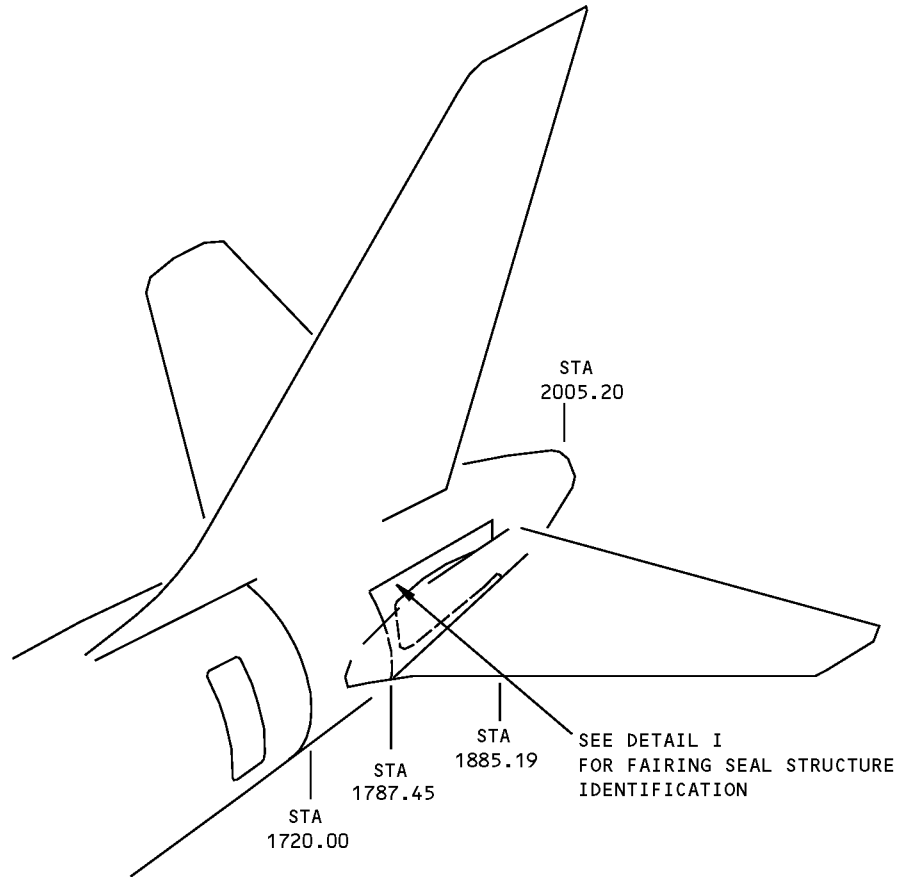


**DAMAGE CLEANUP AND SEALING
OF EDGE EROSION
DETAIL VIII**

**Section 48 Seal Fairing Skin Allowable Damage
Figure 101 (Sheet 4 of 4)**

**757-200
STRUCTURAL REPAIR MANUAL**

IDENTIFICATION 1 - SECTION 48 - SEAL FAIRING STRUCTURE

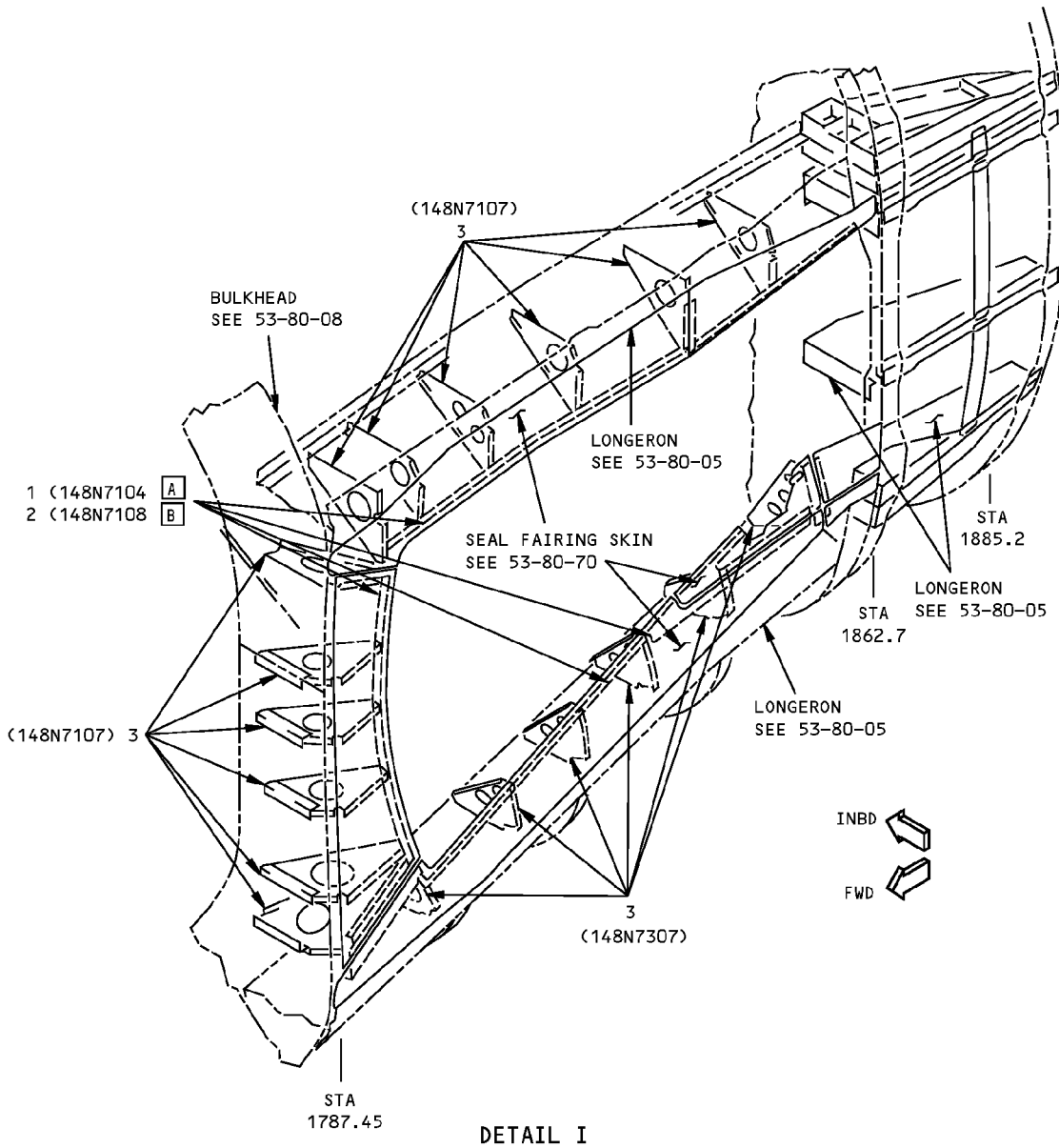


NOTES

- A** FOR CUM LINE NUMBERS:
1 THRU 3
- B** FOR CUM LINE NUMBERS:
4 AND ON

**Section 48 Seal Fairing Structure Identification
Figure 1 (Sheet 1 of 2)**

**757-200
STRUCTURAL REPAIR MANUAL**



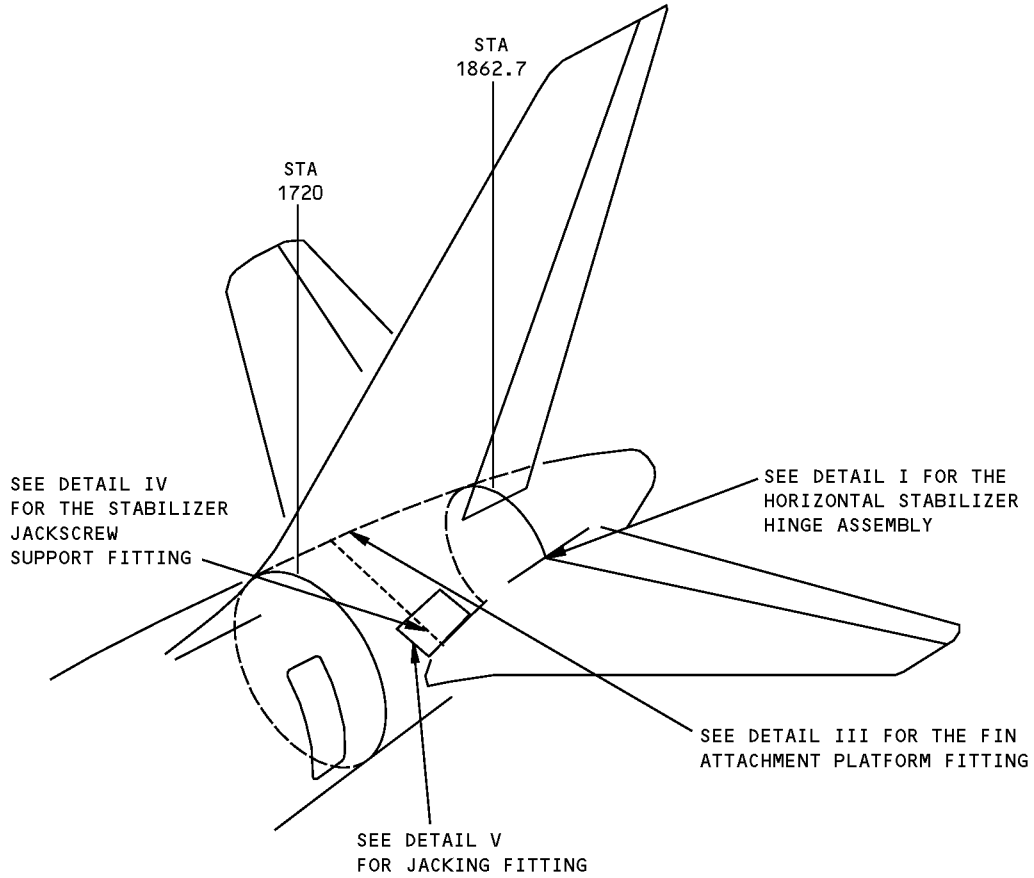
ITEM	DESCRIPTION	GAGE	MATERIAL	EFFECTIVITY
1	ANGLE	0.050	7075-T6	A
2	ANGLE	0.050	2024-T42	B
3	BRACKET	0.050	2024-T42	

LIST OF MATERIALS FOR DETAIL I

**Section 48 Seal Fairing Structure Identification
Figure 1 (Sheet 2 of 2)**

**757-200
STRUCTURAL REPAIR MANUAL**

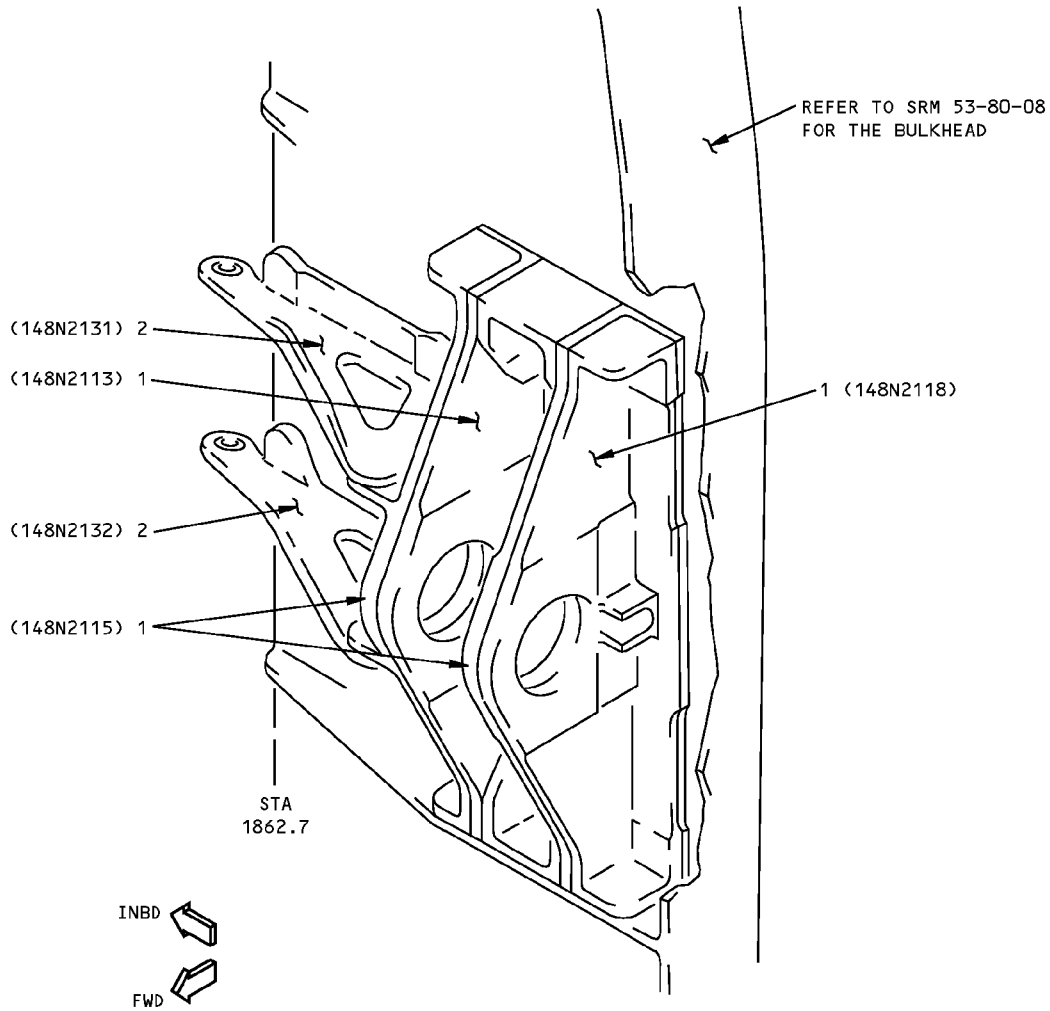
IDENTIFICATION 1 - SECTION 48 - ATTACHMENT FITTINGS



**Section 48 Attachment Fitting Identification
Figure 1 (Sheet 1 of 6)**

**757-200
STRUCTURAL REPAIR MANUAL**

REFERENCE DRAWING
148N2112



**HORIZONTAL STABILIZER HINGE ASSEMBLY
DETAIL I**

ITEM	DESCRIPTION	GAGE	MATERIAL	EFFECTIVITY
1	FITTING	3.5	FORGING 7050-T736	
2	FITTING	4.0	FORGING 7050-T73652	

LIST OF MATERIALS FOR DETAIL I

**Section 48 Attachment Fitting Identification
Figure 1 (Sheet 2 of 6)**

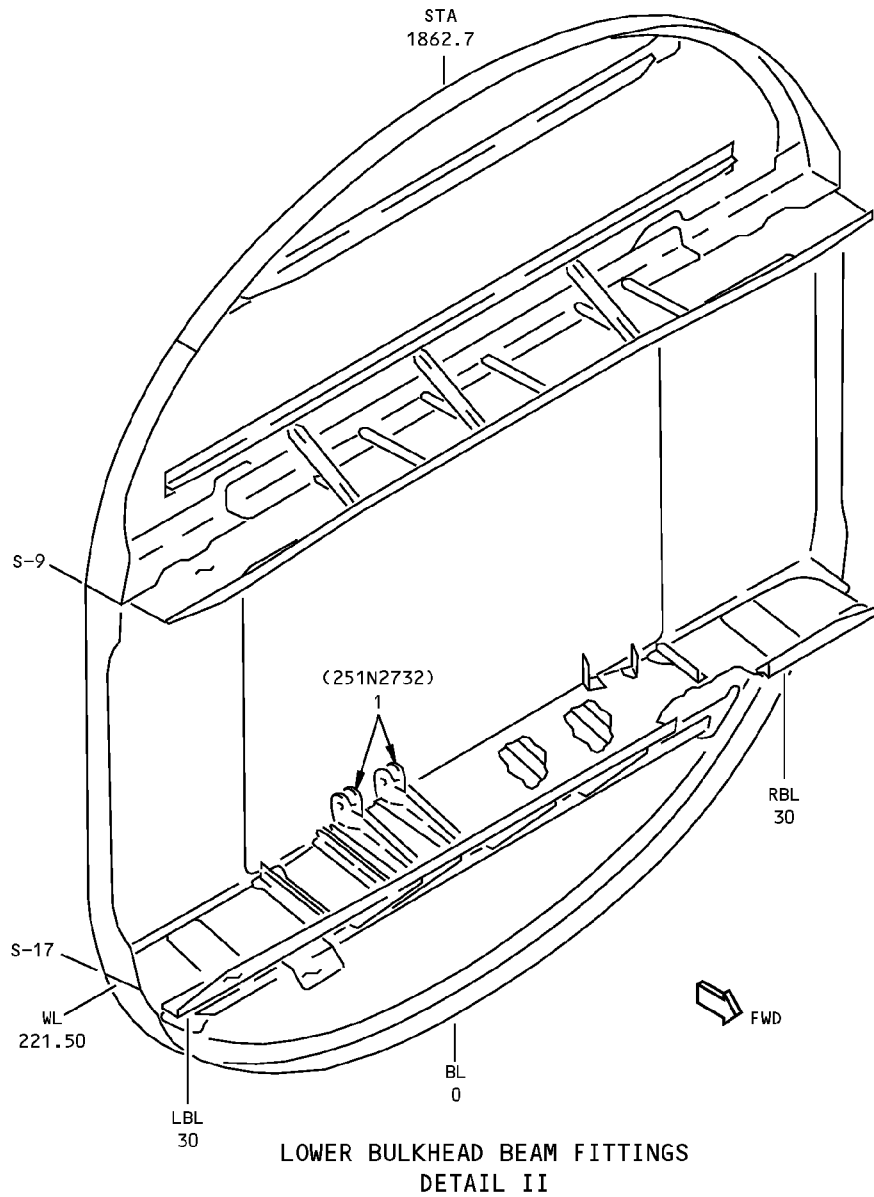
IDENTIFICATION 1
Page 2
Jan 20/2005

53-80-90

D634N201

**757-200
STRUCTURAL REPAIR MANUAL**

REFERENCE DRAWING
148N2202



ITEM	DESCRIPTION	GAGE	MATERIAL	EFFECTIVITY
1	ELEVATOR SERVO FITTING	2.00	7075-T73 DIE FORGING	

LIST OF MATERIALS FOR DETAIL II

**Section 48 Attachment Fitting Identification
Figure 1 (Sheet 3 of 6)**

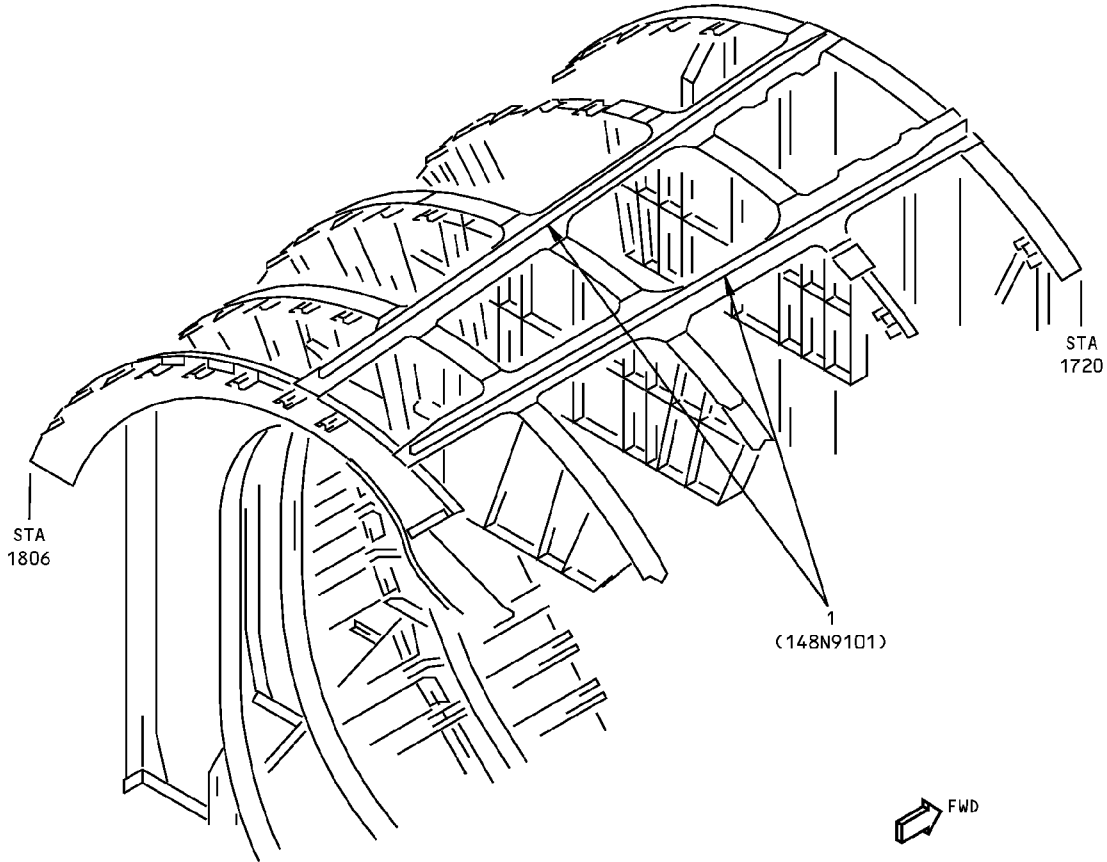
IDENTIFICATION 1
Page 3
Jan 20/2005

53-80-90

D634N201

**757-200
STRUCTURAL REPAIR MANUAL**

REFERENCE DRAWING
148N3101



**FIN ATTACHMENT PLATFORM FITTING
DETAIL III**

ITEM	DESCRIPTION	GAGE	MATERIAL	EFFECTIVITY
1	PLATFORM FITTING	1.25	7075-T7351	

LIST OF MATERIALS FOR DETAIL III

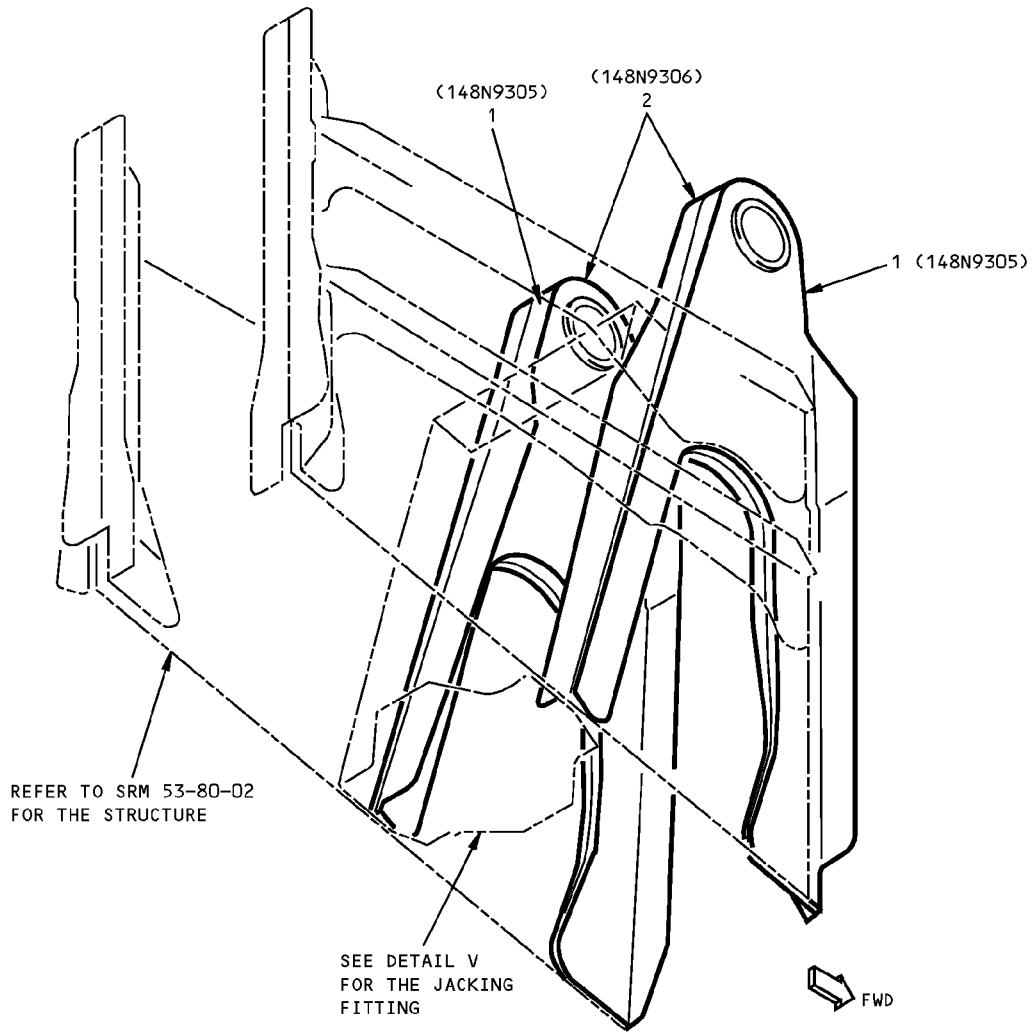
**Section 48 Attachment Fitting Identification
Figure 1 (Sheet 4 of 6)**

IDENTIFICATION 1
Page 4
Jan 20/2005

53-80-90

D634N201

**757-200
STRUCTURAL REPAIR MANUAL**



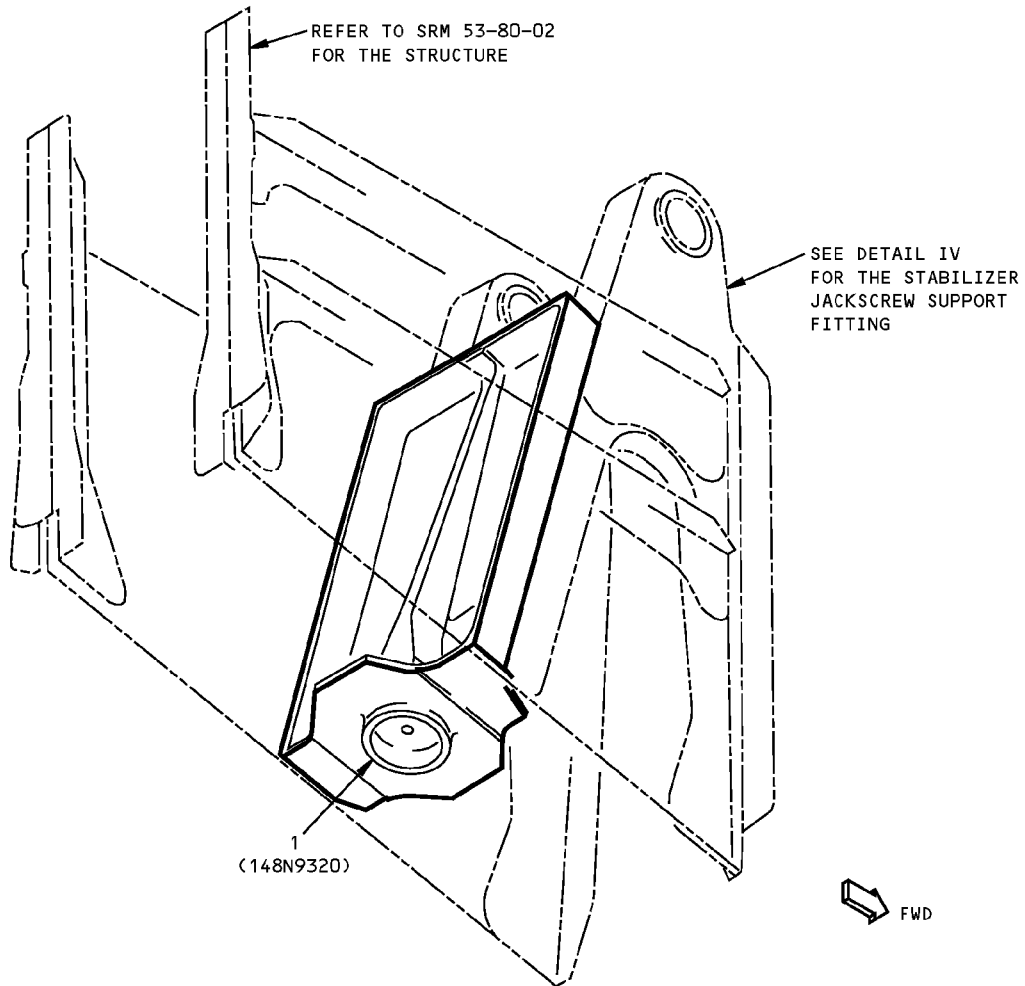
**STABILIZER JACKSCREW SUPPORT FITTING
DETAIL IV**

ITEM	DESCRIPTION	GAGE	MATERIAL	EFFECTIVITY
1	FITTING	2.0	7075-T7351 PLATE OPTIONAL: 7075-T7351 FORGING	
2	FITTING		7075-T7351 PLATE OPTIONAL: 7075-T7351 FORGING	

LIST OF MATERIALS FOR DETAIL IV

**Section 48 Attachment Fitting Identification
Figure 1 (Sheet 5 of 6)**

**757-200
STRUCTURAL REPAIR MANUAL**



**JACKING STABILIZATION SUPPORT FITTING
DETAIL V**

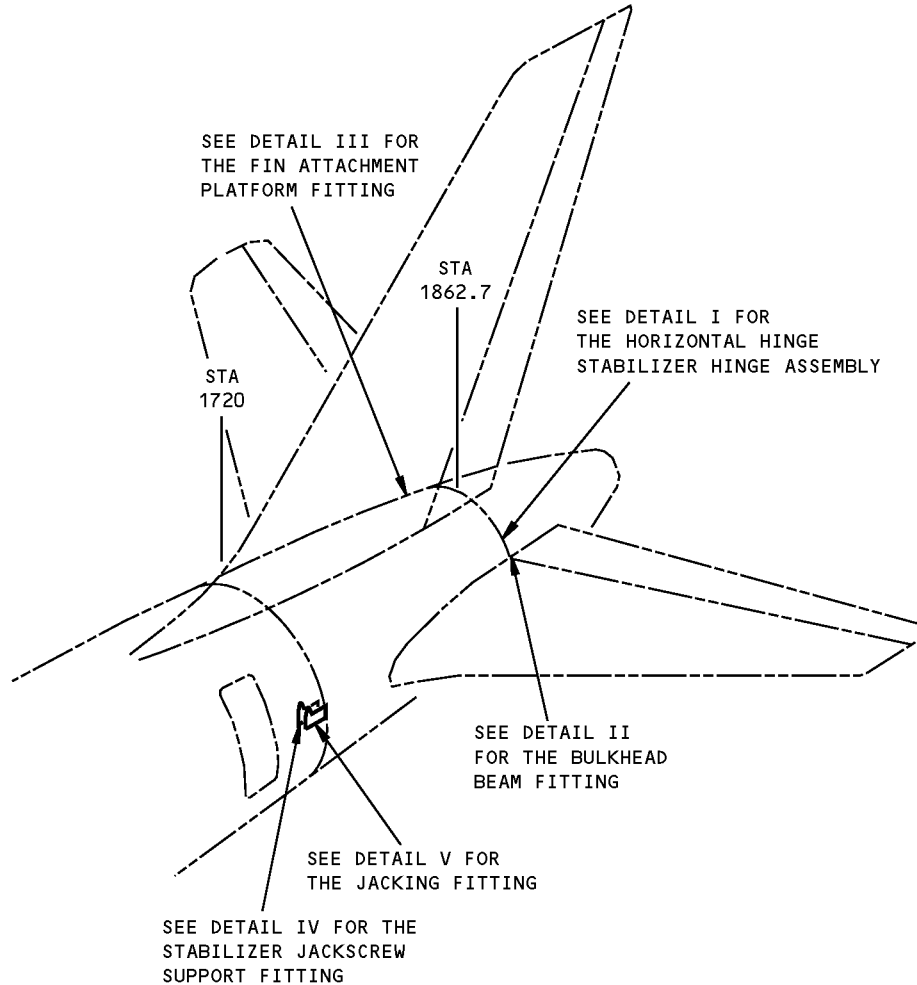
ITEM	DESCRIPTION	GAGE	MATERIAL	EFFECTIVITY
1	FITTING		7050-T736 FORGING PER BMS 7-214 OPTIONAL: 7075-T736 FORGED BLOCK PER BMS 7-214	

LIST OF MATERIALS FOR DETAIL V

**Section 48 Attachment Fitting Identification
Figure 1 (Sheet 6 of 6)**

**757-200
STRUCTURAL REPAIR MANUAL**

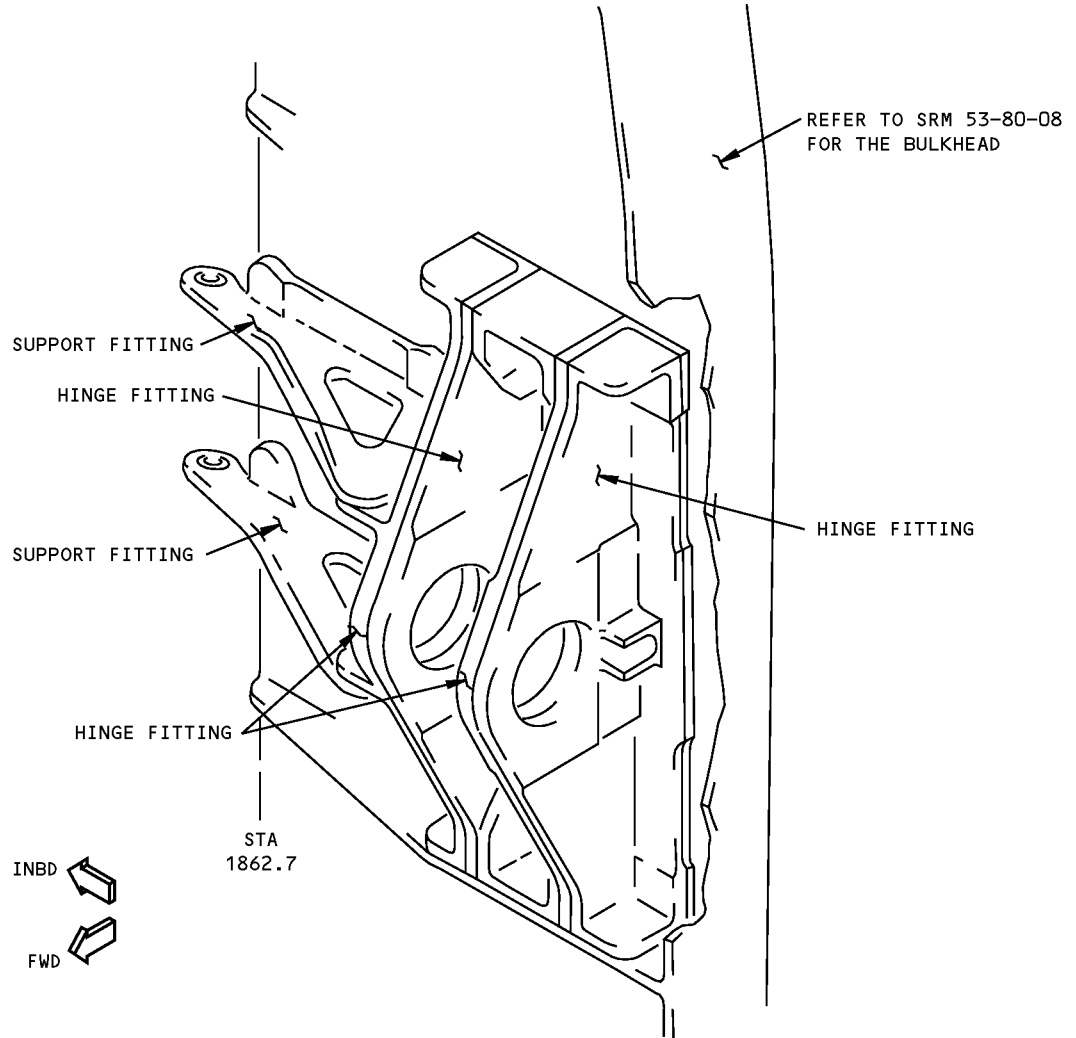
ALLOWABLE DAMAGE GENERAL - SECTION 48 - ATTACHMENT FITTINGS



**Section 48 Attachment Fitting Allowable Damage
Figure 101 (Sheet 1 of 7)**

**757-200
STRUCTURAL REPAIR MANUAL**

REFERENCE DRAWING
148N2112



MATERIAL: FORGED ALUMINUM

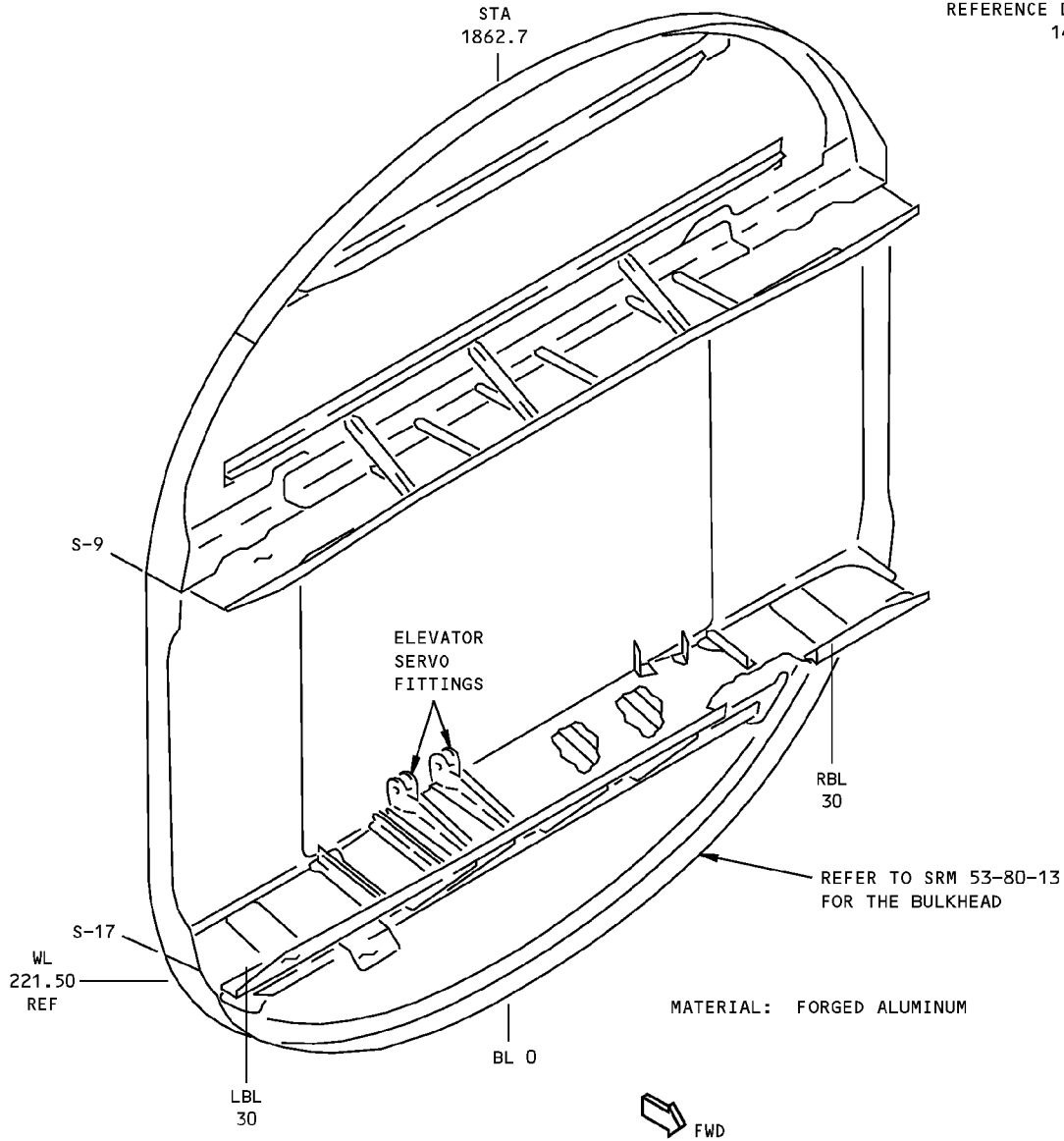
**HORIZONTAL STABILIZER HINGE ASSEMBLY
DETAIL I**

DESCRIPTION	CRACKS	NICKS, GOUGES AND CORROSION	DENTS	HOLES AND PUNCTURES
HINGE FITTING	A	B	NOT PERMITTED	NOT PERMITTED
SUPPORT FITTING	A	B	NOT PERMITTED	NOT PERMITTED

**Section 48 Attachment Fitting Allowable Damage
Figure 101 (Sheet 2 of 7)**

**757-200
STRUCTURAL REPAIR MANUAL**

REFERENCE DRAWING
148N2202



NOTE: SHOT PEENING IS NECESSARY FOR THE REWORKED AREA OF THESE PARTS.

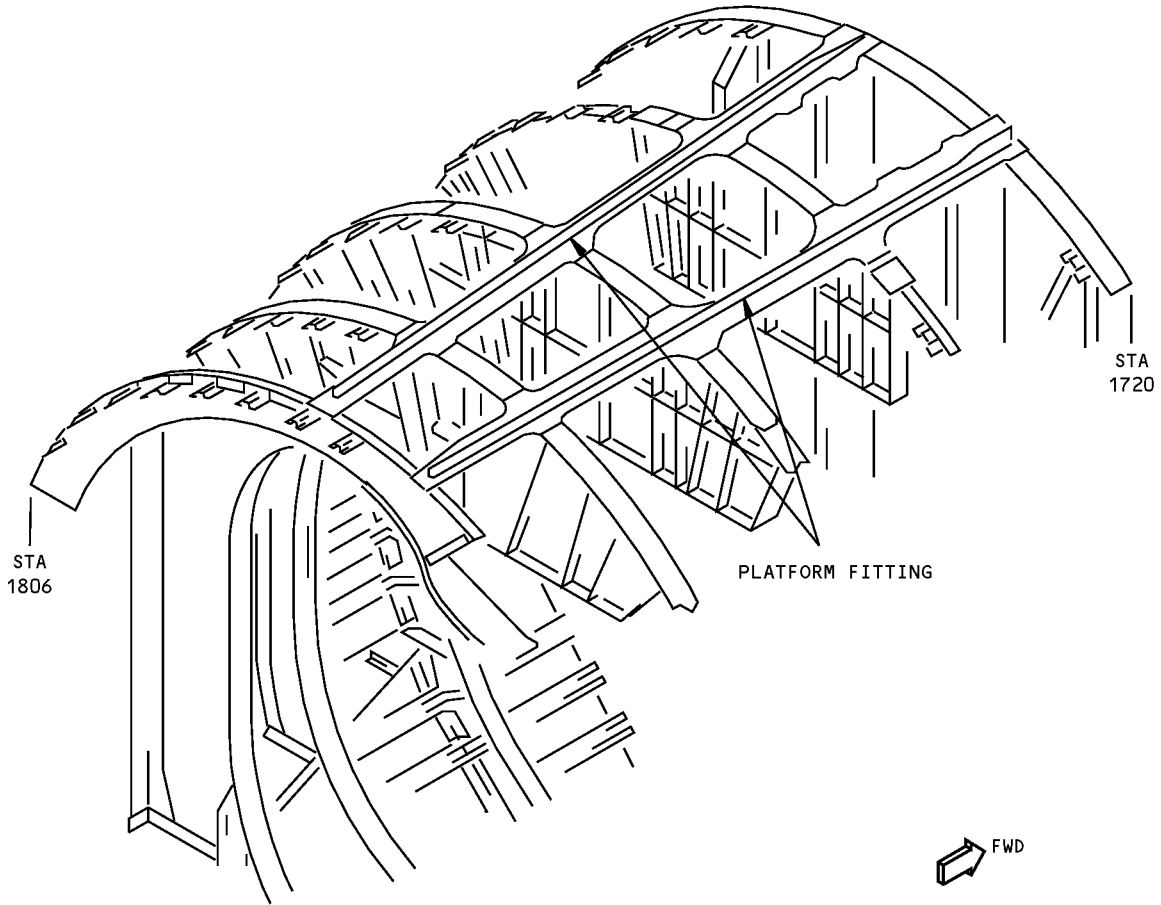
**LOWER BULKHEAD BEAM FITTING
DETAIL II**

DESCRIPTION	CRACKS	NICKS, GOUGES AND CORROSION	DENTS	HOLES AND PUNCTURES
ELEVATOR SERVO FITTING	A	B	NOT PERMITTED	NOT PERMITTED

**Section 48 Attachment Fitting Allowable Damage
Figure 101 (Sheet 3 of 7)**

**757-200
STRUCTURAL REPAIR MANUAL**

REFERENCE DRAWING
148N3101



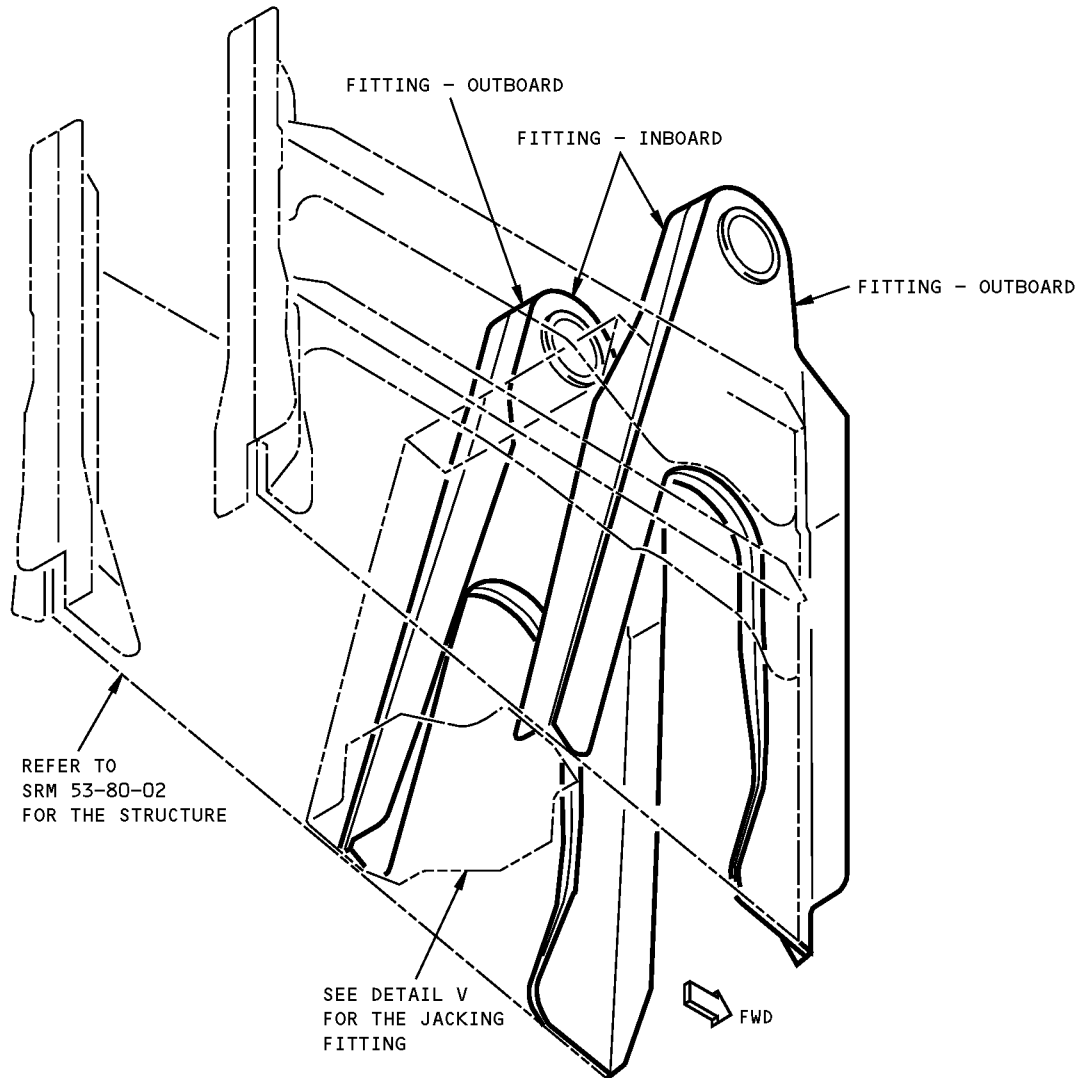
MATERIAL: MACHINED ALUMINUM

**FIN ATTACHMENT PLATFORM FITTING
DETAIL III**

DESCRIPTION	CRACKS	NICKS, GOUGES AND CORROSION	DENTS	HOLES AND PUNCTURES
PLATFORM FITTING	A	B	NOT PERMITTED	NOT PERMITTED

**Section 48 Attachment Fitting Allowable Damage
Figure 101 (Sheet 4 of 7)**

**757-200
STRUCTURAL REPAIR MANUAL**



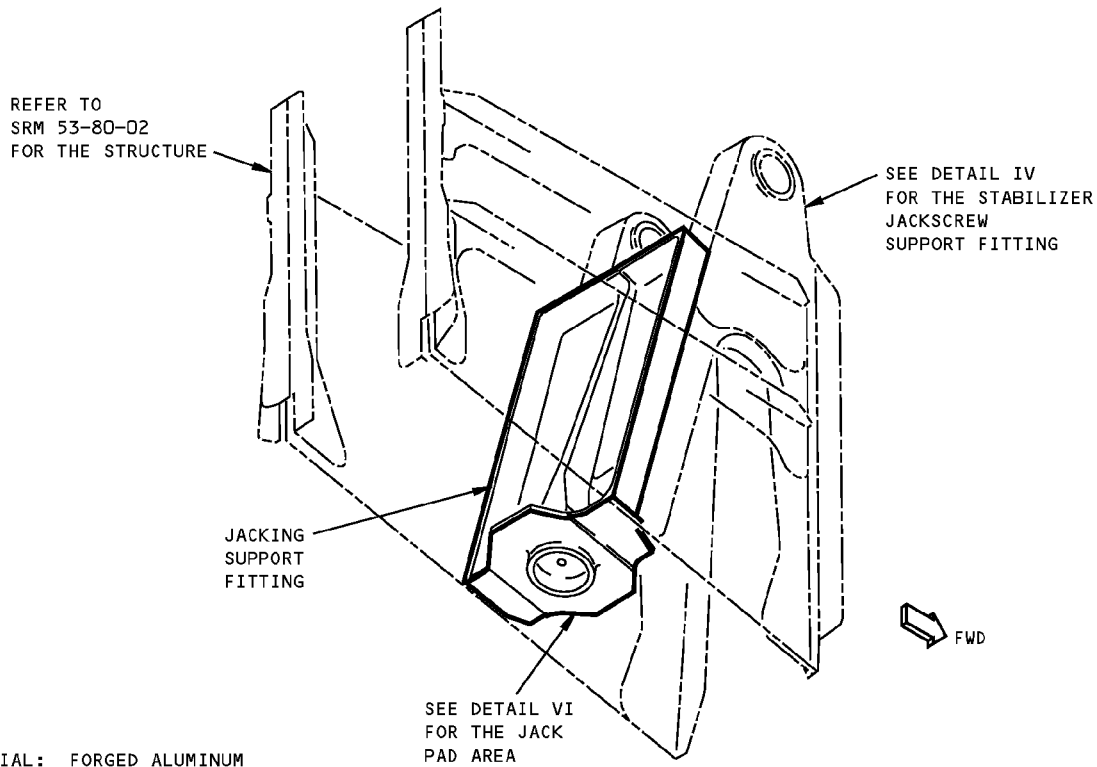
MATERIAL: FORGED ALUMINUM OR ALUMINUM PLATE

**STABILIZER JACKSCREW SUPPORT FITTING
DETAIL IV**

DESCRIPTION	CRACKS	NICKS, GOUGES AND CORROSION	DENTS	HOLES AND PUNCTURES
FITTING - INBOARD	A	B	NOT PERMITTED	NOT PERMITTED
FITTING - OUTBOARD	A	B	NOT PERMITTED	NOT PERMITTED

**Section 48 Attachment Fitting Allowable Damage
Figure 101 (Sheet 5 of 7)**

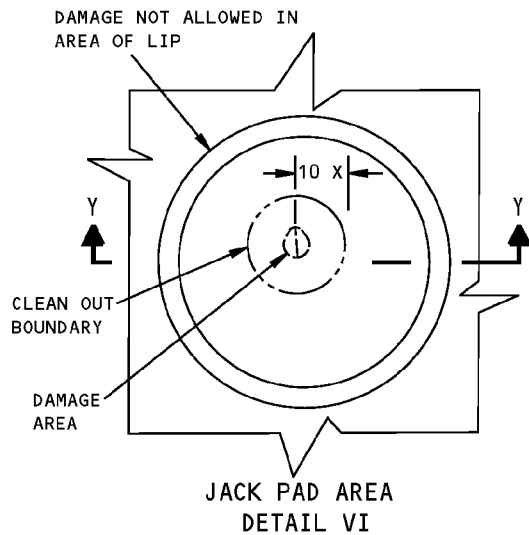
**757-200
STRUCTURAL REPAIR MANUAL**



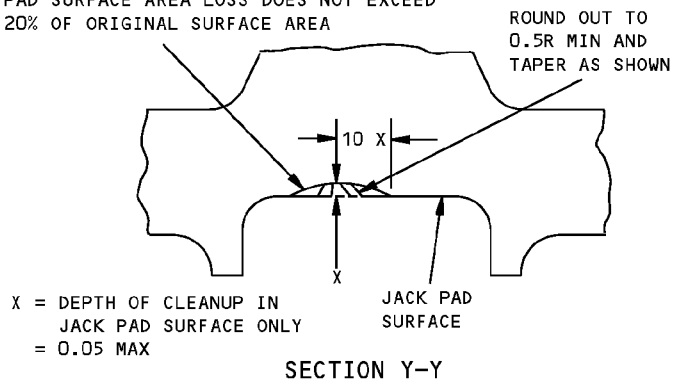
MATERIAL: FORGED ALUMINUM

DESCRIPTION	CRACKS	NICKS, GOUGES AND CORROSION	DENTS	HOLES AND PUNCTURES
JACKING SUPPORT FITTING	A	C AND DETAIL VI	NOT PERMITTED	NOT PERMITTED

**JACKING STABILIZATION SUPPORT FITTING
DETAIL V**



REWORK MAY BE MADE IN MORE THAN ONE PLACE ON JACK PAD SURFACE PROVIDED PAD SURFACE AREA LOSS DOES NOT EXCEED 20% OF ORIGINAL SURFACE AREA



X = DEPTH OF CLEANUP IN JACK PAD SURFACE ONLY
= 0.05 MAX

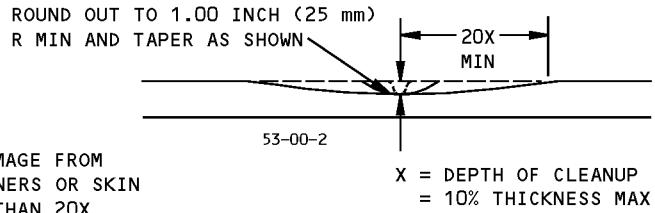
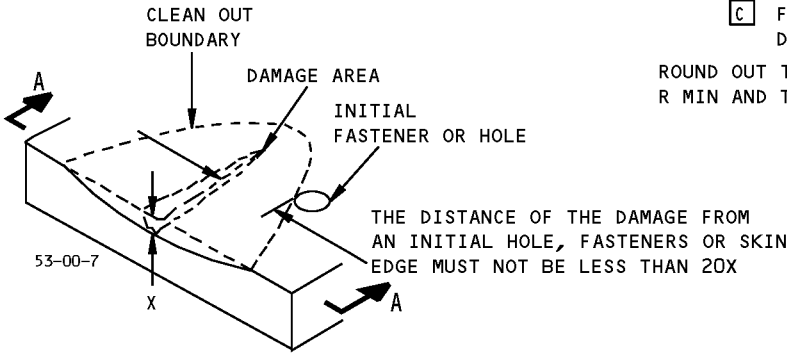
**Section 48 Attachment Fitting Allowable Damage
Figure 101 (Sheet 6 of 7)**

STRUCTURAL REPAIR MANUAL

NOTES

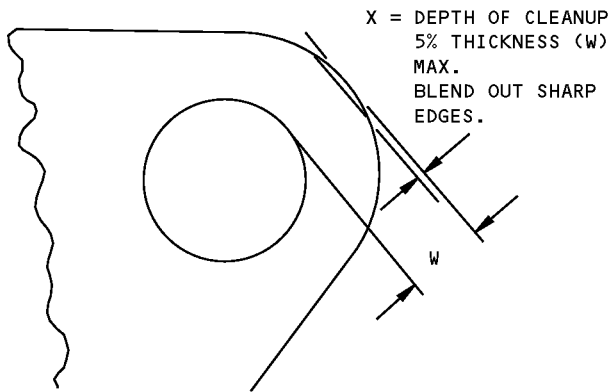
- SHOT PEEN REWORKED AREAS AS SHOWN IN SRM 51-20-06
- REFINISH REWORKED AREAS AS SHOWN IN SRM 51-20
- REFER TO SRM 51-10-02 FOR INSPECTION AND REMOVAL OF DAMAGE

- A** CRACKS ARE NOT PERMITTED EXCEPT FOR EDGE CRACKS WHICH MUST BE REMOVED AS GIVEN IN DETAIL VIII
- B** FOR EDGE DAMAGE SEE DETAIL VIII. FOR LUG DAMAGE SEE DETAIL VII. FOR OTHER DAMAGE SEE DETAIL VI. DAMAGE IS NOT PERMITTED IN VICINITY OF BUSHINGS
- C** FOR EDGE DAMAGE SEE DETAIL VIII FOR OTHER DAMAGE SEE DETAIL VI



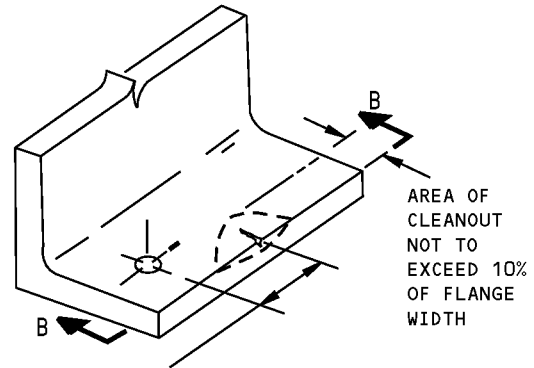
SECTION A-A

**REMOVAL OF NICK, GOUGE AND SCRATCH DAMAGE ON A SURFACE
DETAIL VIII**

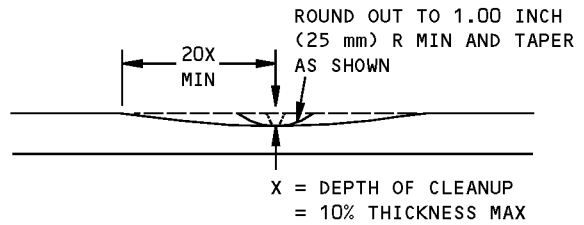


DAMAGE CLEANUP FOR EDGES OF LUG

DETAIL IX



THE DISTANCE OF THE DAMAGE FROM AN EXISTING HOLE, FASTENERS OR EDGE MUST NOT BE LESS THAN 20X



SECTION B-B

REMOVAL OF NICK OR CRACK DAMAGE ON AN EDGE

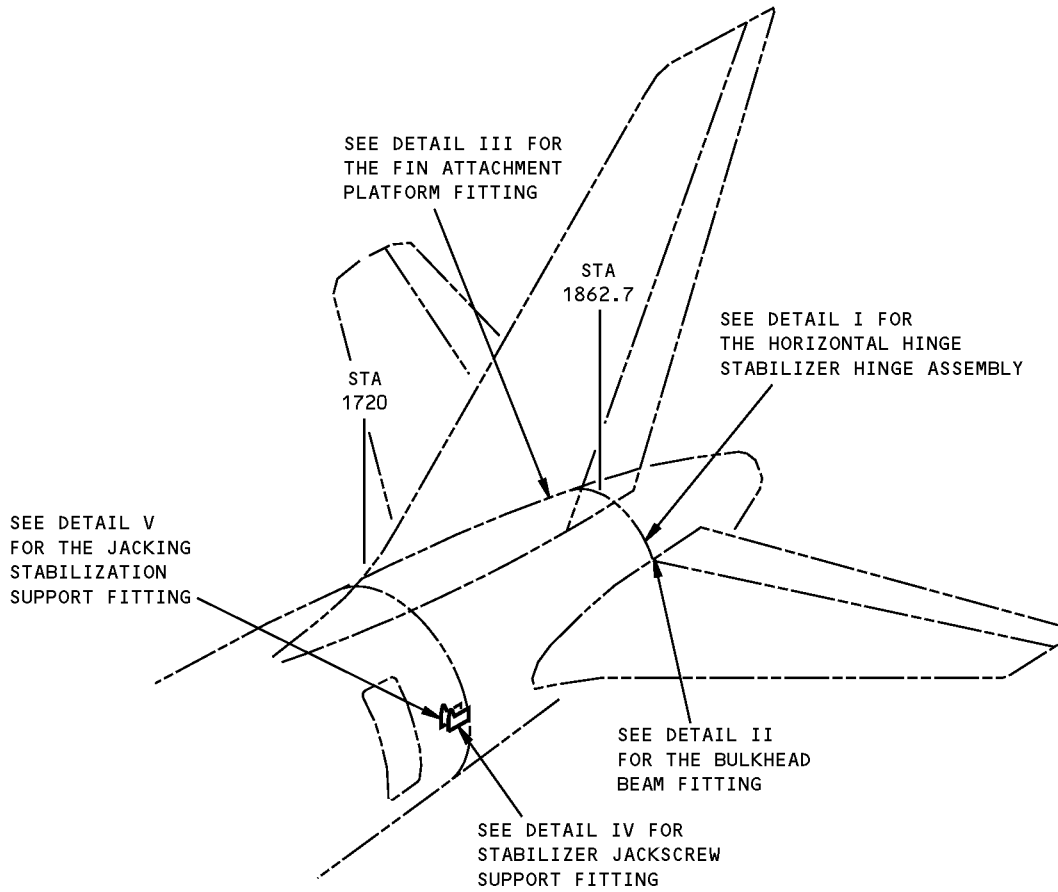
DETAIL X

**Section 48 Attachment Fitting Allowable Damage
Figure 101 (Sheet 7 of 7)**

**757-200
STRUCTURAL REPAIR MANUAL**

REPAIR GENERAL - SECTION 48 - ATTACHMENT FITTINGS

REFERENCE DRAWING
148N2112



**Section 48 Attachment Fittings Repair
Figure 201 (Sheet 1 of 6)**

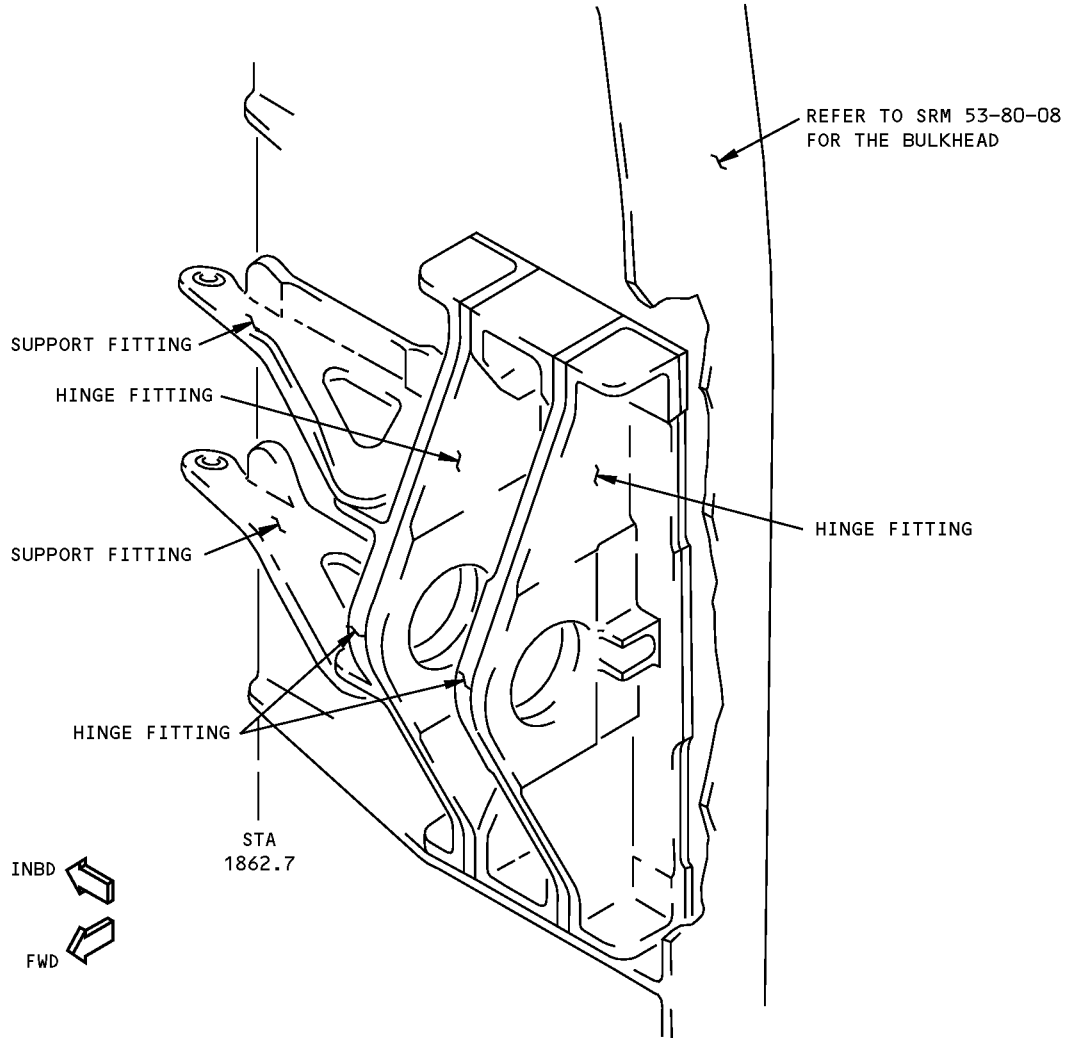
D634N201

53-80-90

REPAIR GENERAL
Page 201
Jan 20/2005

**757-200
STRUCTURAL REPAIR MANUAL**

REFERENCE DRAWING
148N2112



**HORIZONTAL STABILIZER HINGE ASSEMBLY
DETAIL I**

NOTES

- THE BOEING COMPANY HAS NOT FOUND IT NECESSARY TO SUPPLY REPAIRS FOR THESE PARTS AT THIS TIME.

**Section 48 Attachment Fittings Repair
Figure 201 (Sheet 2 of 6)**

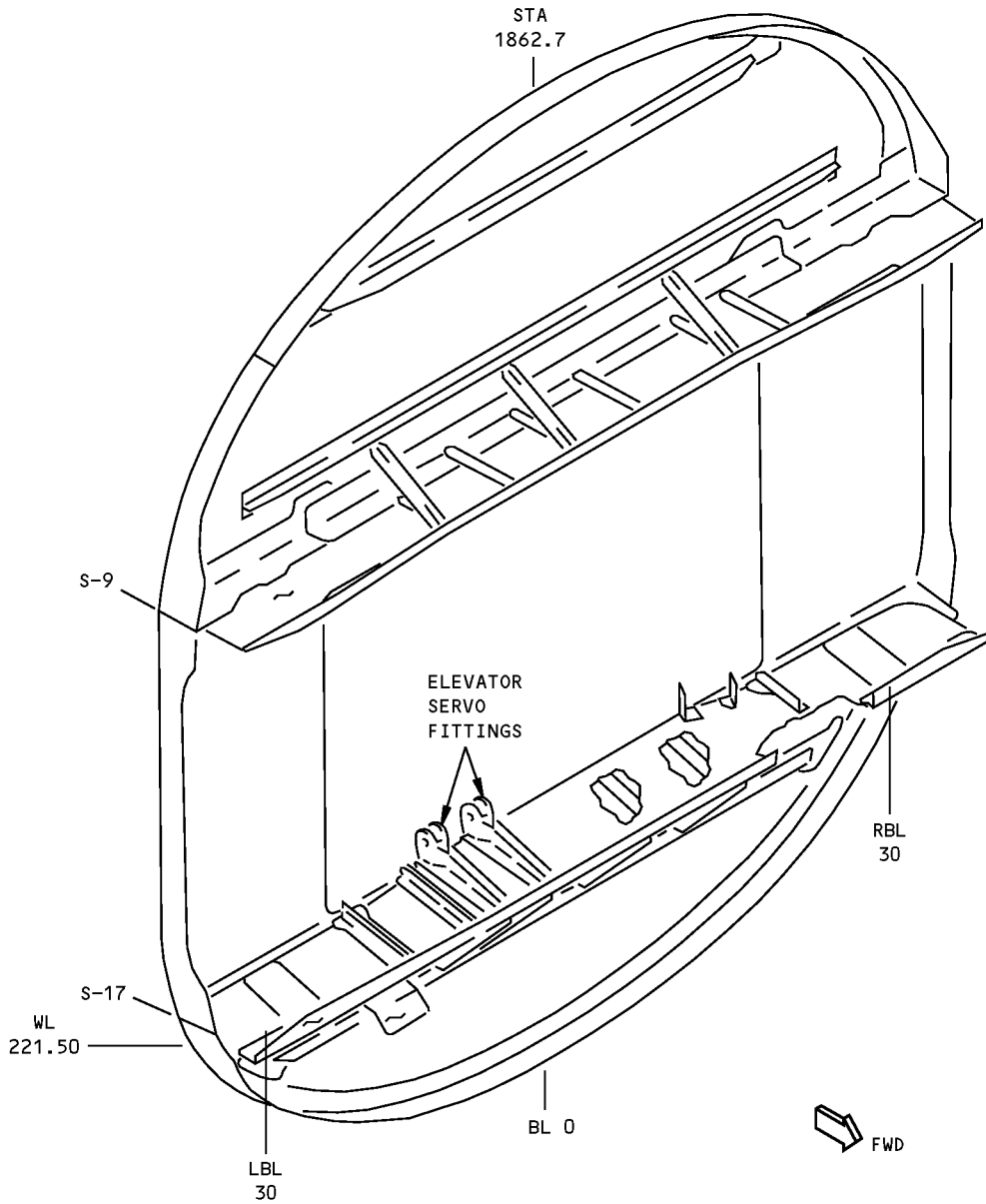
D634N201

53-80-90

REPAIR GENERAL
Page 202
Jan 20/2005

**757-200
STRUCTURAL REPAIR MANUAL**

REFERENCE DRAWING
148N2202



**LOWER BULKHEAD BEAM FITTINGS
DETAIL II**

NOTES

- THE BOEING COMPANY HAS NOT FOUND IT NECESSARY TO SUPPLY REPAIRS FOR THESE PARTS AT THIS TIME.

**Section 48 Attachment Fittings Repair
Figure 201 (Sheet 3 of 6)**

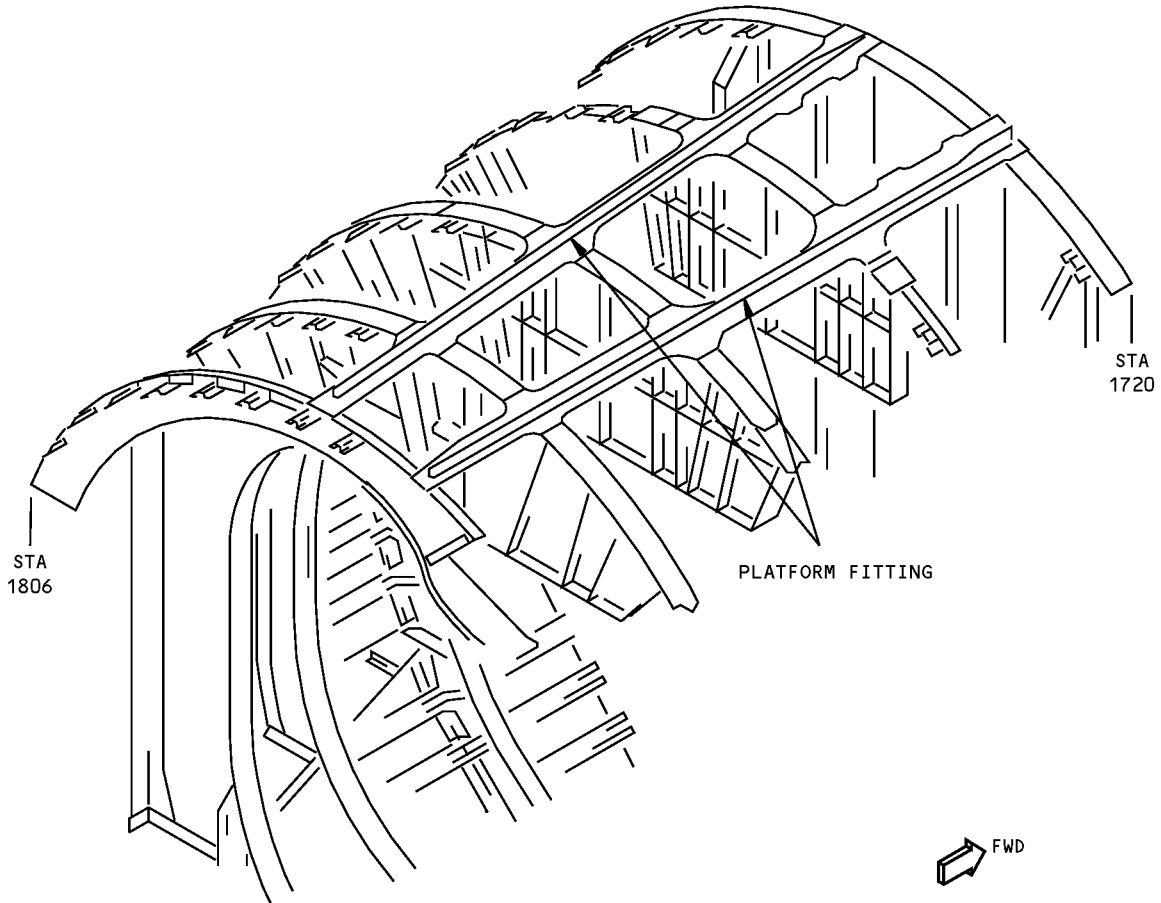
D634N201

53-80-90

REPAIR GENERAL
Page 203
Jan 20/2005

**757-200
STRUCTURAL REPAIR MANUAL**

REFERENCE DRAWING
148N3101



**FIN ATTACHMENT PLATFORM FITTING
DETAIL III**

NOTES

- THE BOEING COMPANY HAS NOT FOUND IT NECESSARY TO SUPPLY REPAIRS FOR THESE PARTS AT THIS TIME.

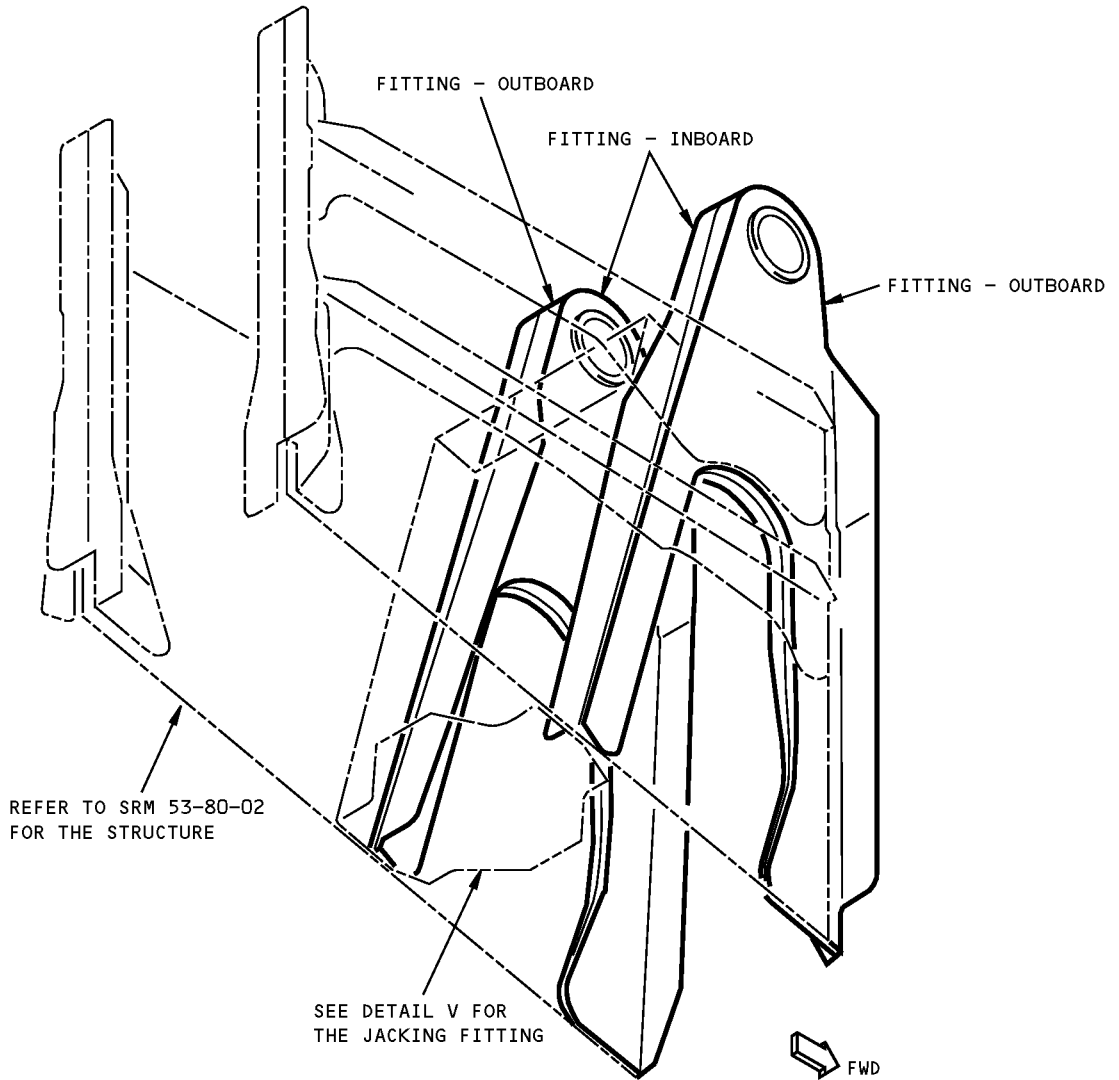
**Section 48 Attachment Fittings Repair
Figure 201 (Sheet 4 of 6)**

D634N201

53-80-90

REPAIR GENERAL
Page 204
Jan 20/2005

**757-200
STRUCTURAL REPAIR MANUAL**

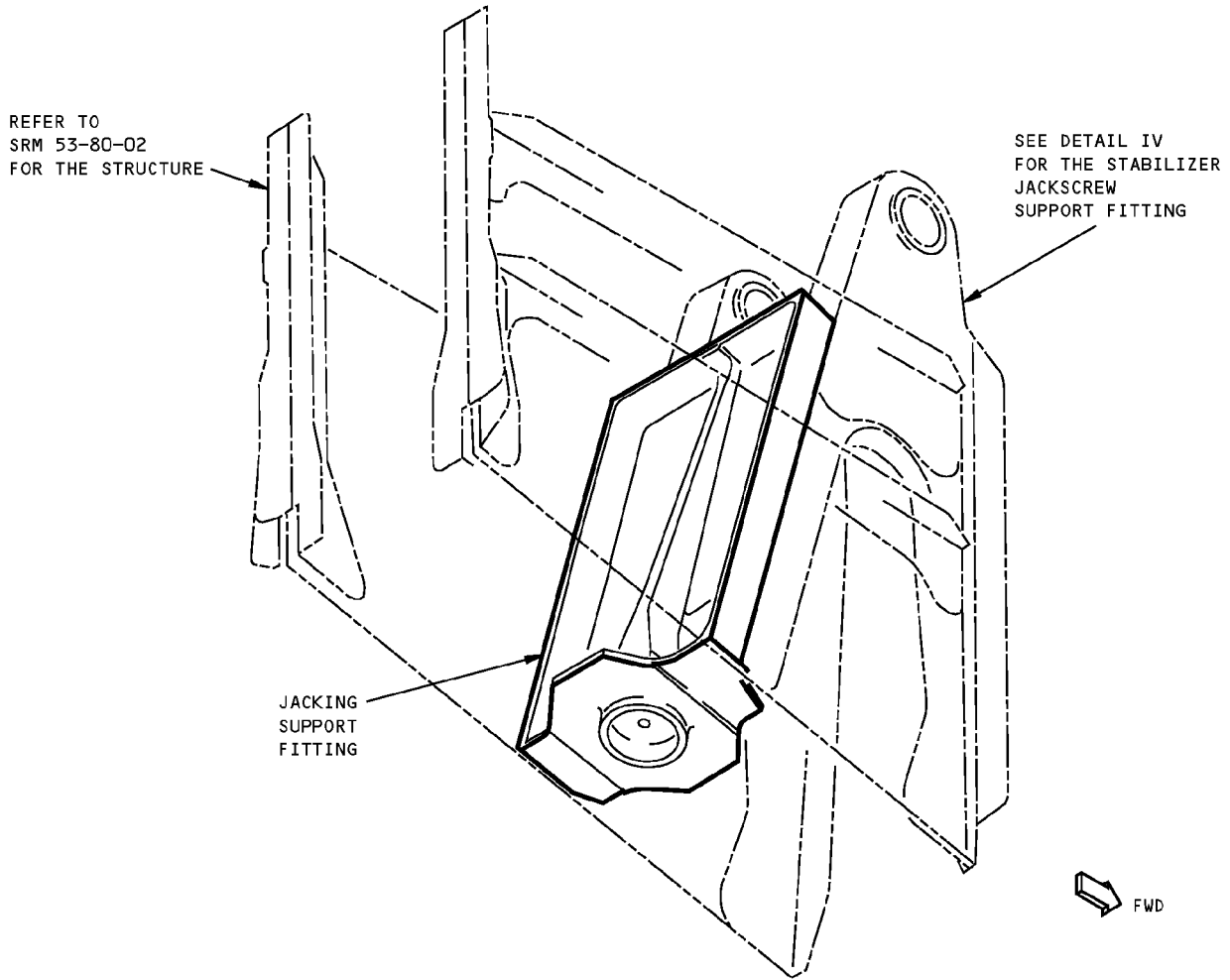


**STABILIZER JACKSCREW SUPPORT FITTING
DETAIL IV**

NOTES

- THE BOEING COMPANY HAS NOT FOUND IT NECESSARY TO SUPPLY REPAIRS FOR THESE PARTS AT THIS TIME.

**Section 48 Attachment Fittings Repair
Figure 201 (Sheet 5 of 6)**



JACKING STABILIZATION SUPPORT FITTING
DETAIL V

NOTES

- THE BOEING COMPANY HAS NOT FOUND IT NECESSARY TO SUPPLY REPAIRS FOR THESE PARTS AT THIS TIME.

**Section 48 Attachment Fittings Repair
Figure 201 (Sheet 6 of 6)**