

TRANSITION METALS IN ORGANIC SYNTHESIS  
ANNUAL SURVEY COVERING THE YEAR 1986

Louis S. Hegedus

Department of Chemistry, Colorado State University, Fort Collins, CO 80523 USA

CONTENTS

I.	General Comments	149
II.	Carbon-Carbon Bond Forming Reactions	149
A.	Alkylations	149
1.	Alkylation of Organic Halides, Tosylates, Acetates, and Epoxides	149
2.	Alkylation of Acid Derivatives	168
3.	Alkylation of Olefins	171
4.	Decomposition of Diazoalkanes and Other Cyclopropanations	183
5.	Cycloaddition Reactions	190
6.	Alkylation of Alkynes	195
7.	Alkylation of Allyl and Propargyl, and Allenyl Systems	201
8.	Coupling Reactions	219
9.	Alkylation of $\pi$ -Allyl Complexes	227
10.	Alkylation of Carbonyl Compounds	232
11.	Alkylation of Aromatic Compounds	242
12.	Alkylation of Dienyl and Diene Complexes	249
13.	Metal-Carbene Reactions	253
14.	Alkylation of Metal Acyl Enolates	260
B.	Conjugate Addition	264
C.	Acylation Reactions (Excluding Hydroformylation)	275
1.	Carbonylation of Alkenes and Alkynes	275
2.	Carbonylation of Halides	279
3.	Carbonylation of Nitrogen Compounds	285
4.	Carbonylation of Oxygen Compounds	286
5.	Miscellaneous Carbonylations	287
6.	Decarbonylation Reactions	287
7.	Reactions of Carbon Dioxide	288
D.	Oligomerization	292
E.	Rearrangements	300
1.	Metathesis	300
2.	Olefin Isomerization	302
3.	Rearrangements of Allylic and Propargylic Oxygen and Nitrogen Compounds	303
4.	Skeletal Rearrangements	306

	5. Miscellaneous Rearrangements	309
III.	Functional Group Preparations	310
	A. Halides	310
	B. Amides, Nitriles	312
	C. Amines, Alcohols	314
	D. Ethers, Esters, Acids	319
	E. Heterocycles	323
	F. Alkenes, Alkanes	350
	G. Ketones, Aldehydes	356
	H. Organosilanes	361
	I. Miscellaneous	365
IV.	Reviews	370

## I. General Comments

This annual survey covers the literature for 1986 dealing with the use of transition metal intermediates for organic synthetic transformations. It is not a comprehensive review but is limited to reports of discrete systems that lead to at least moderate yields of organic compounds, or that allow unique organic transformations, even if low yields are obtained. Catalytic reactions that lead cleanly to a major product and do not involve extreme conditions are also included. This is not a critical review, but rather a listing of the papers published in the title area.

The papers in this survey are grouped primarily by reaction type rather than by organometallic reagent, since the reader is likely to be more interested in the organic transformation effected than the metal causing it. Oxidation, reduction, and hydroformylation reactions are specifically excluded, and will be covered in a different annual survey. Also excluded are structural and mechanistic studies of organometallic systems unless they present data useful for synthetic application. Finally, reports from the patent literature have not been surveyed since patents are rarely sufficiently detailed to allow reproduction of the reported results.

## II. Carbon-Carbon Bond Forming Reactions

### A. Alkylations

#### 1. Alkylation of Organic Halides, Tosylates, Acetates and Epoxides

Although research in the area of organocuprate chemistry is finally abating, useful extensions continue to be reported. Higher order cuprates were the subject of a dissertation [1]. Epoxides were alkylated with clean *trans* stereochemistry by organocuprates in the presence of  $\text{BF}_3 \cdot \text{Et}_2\text{O}$  (equation 1) [2]. Protected hydroxyproline tosylates were phenylated with overall retention by phenylcuprate reagents (equations 2 and 3) [3]. Methylation of a chiral  $\alpha$ -ketosulfone by dimethyl cuprate was used as a key step in the synthesis of estrone (equation 4) [4].

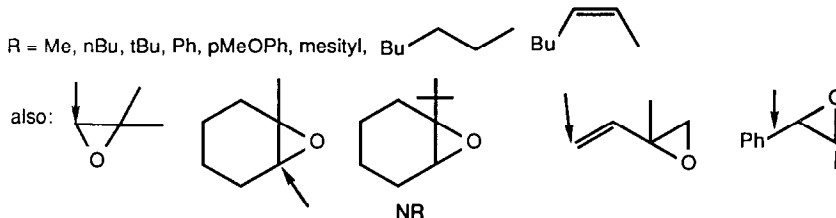
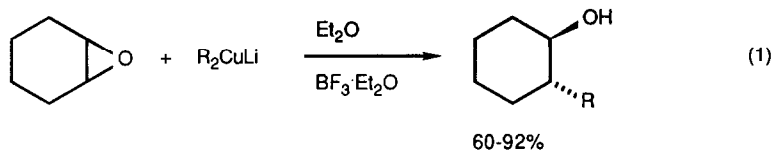

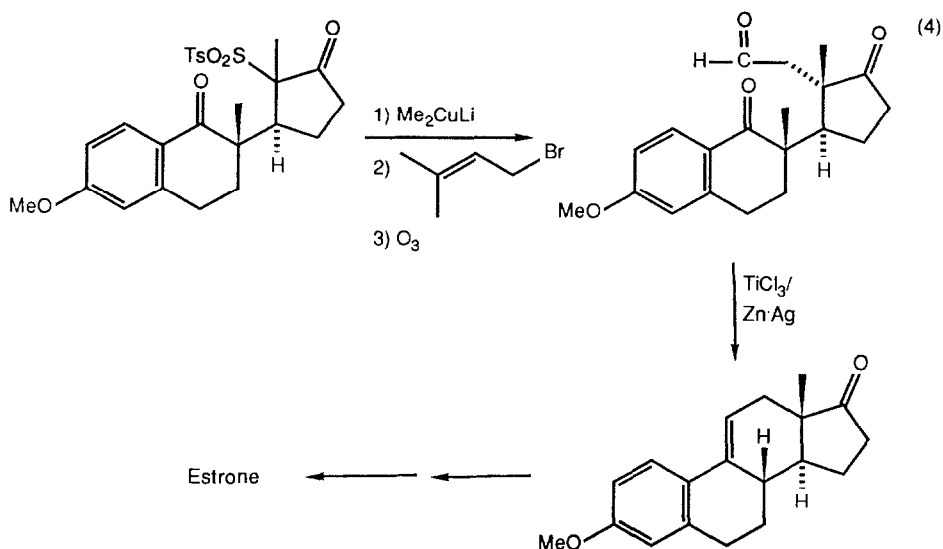
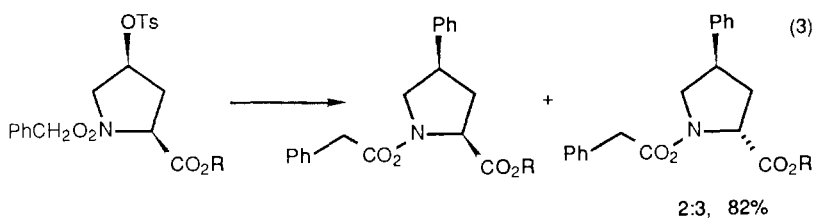
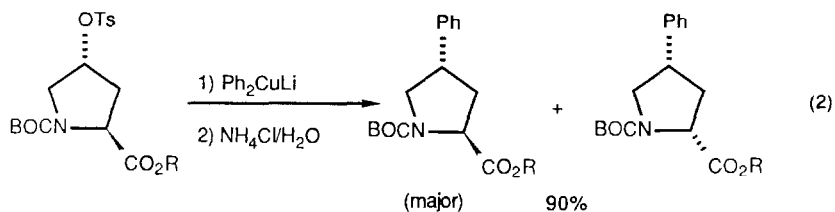

Pyridine-cuprates coupled to aryl iodides (equation 5) [5]. Dienes were synthesized by the carbocupration of alkynes followed by coupling of the thus-formed vinyl cuprate with allylic halides (equation 6) [6]. Thienyl copper reagents alkylated halides and epoxides and added in a 1,4-sense to conjugated enones (equation 7) [7]. Prenylated arenes were synthesized in copper chemistry (equation 8) [8].

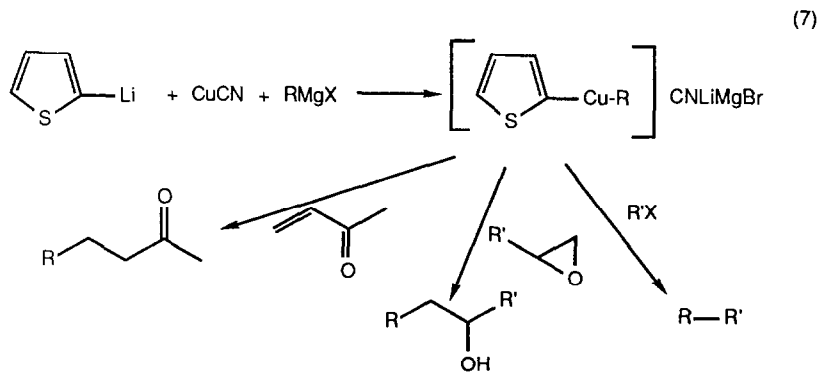
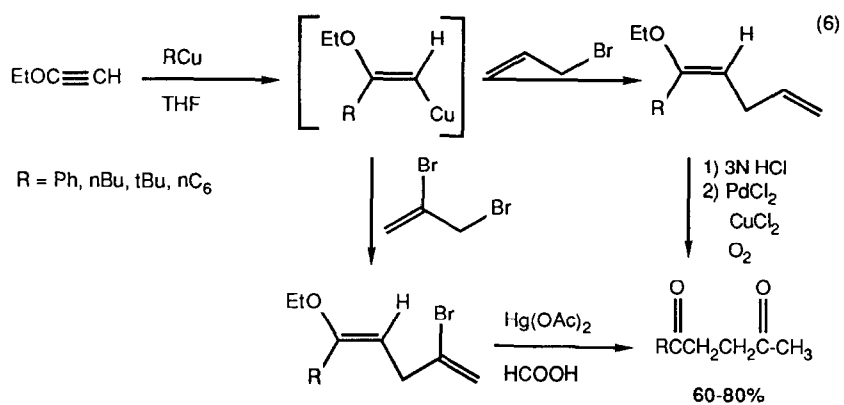
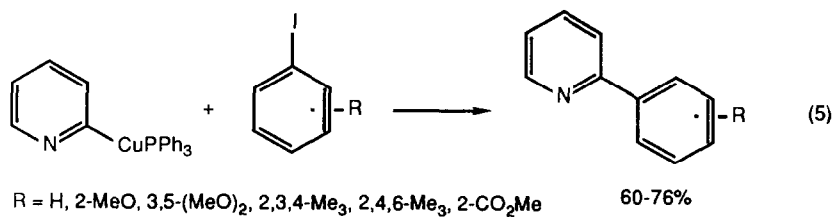

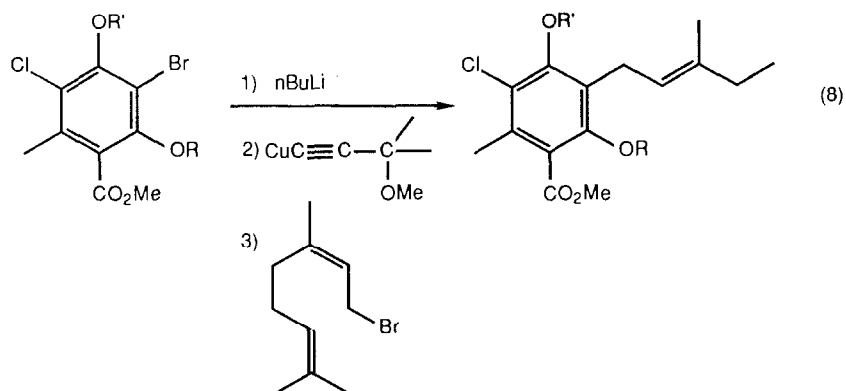

Fluoroalkyl cuprates have been used to introduce fluorinated side chains into organic substrates (equation 9) [9], (equation 10) [10].

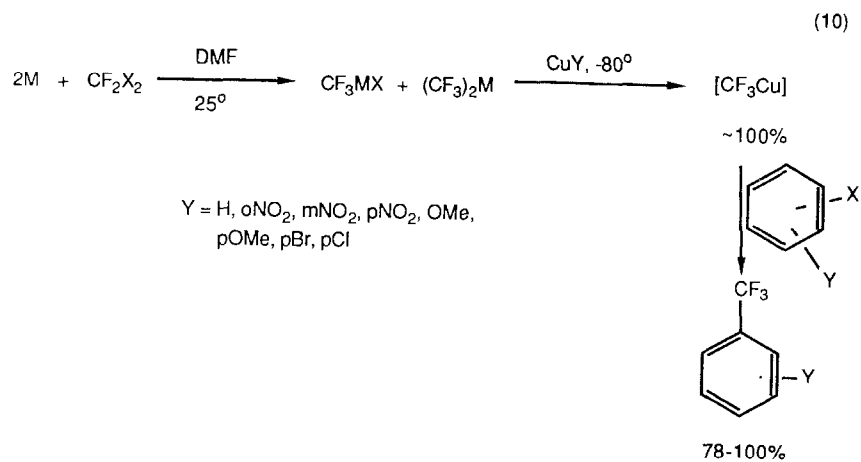
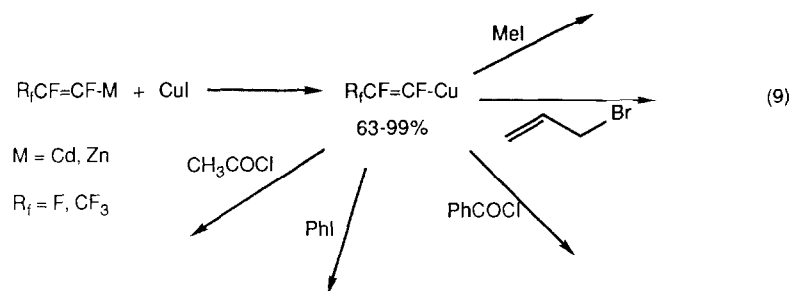



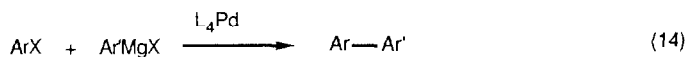

Ar = Ph; 3,4-(MeO)<sub>2</sub>Ph; 4-Me<sub>2</sub>NPh; 4-MeOPh; 2-MePh; 2-Me(TMS)NPh

Ar' = Ph; 2-MeOPh; 4-Me-2-Li indole; 2,4,6-Me<sub>3</sub>Ph

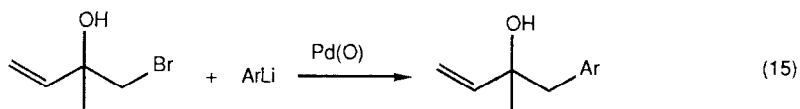

Ar = Ph, 53%; pMePh, 86%;  60%;  78%;

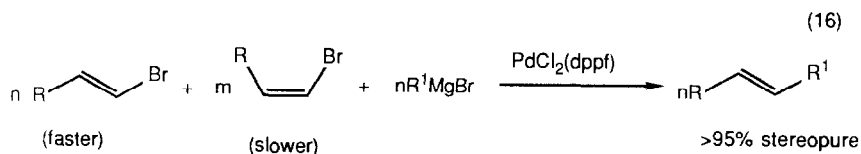
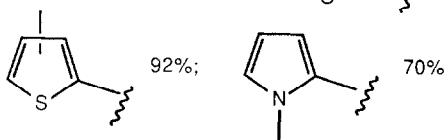

Polythienyls were prepared by coupling thienyl Grignard reagents with dibromothiophenes (equations 17 and 18) [17], (equation 19) [18]. 3-Bromothiophene was alkylated by Grignard reagents in the presence of nickel catalysts (equation 20) [19]. Vinyl sulfones were alkylated, with displacement of the sulfone, by Grignard reagents under nickel catalysis [20]. Chlorophosphazines were alkylated by ketones via organocopper chemistry (equation 21) [21].

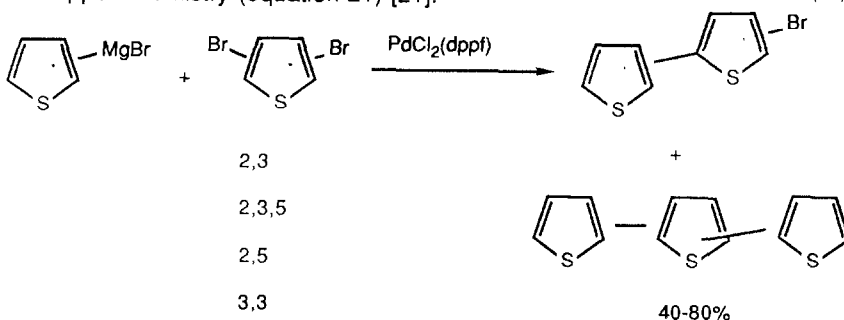



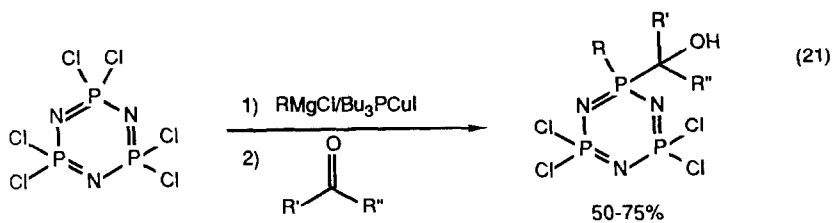
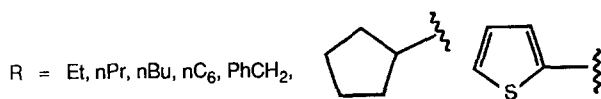
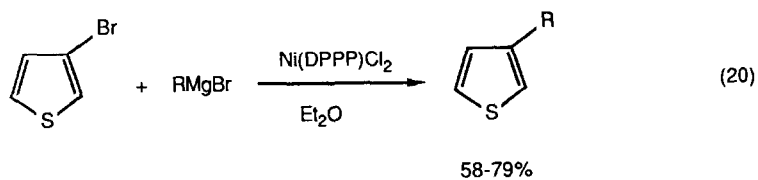
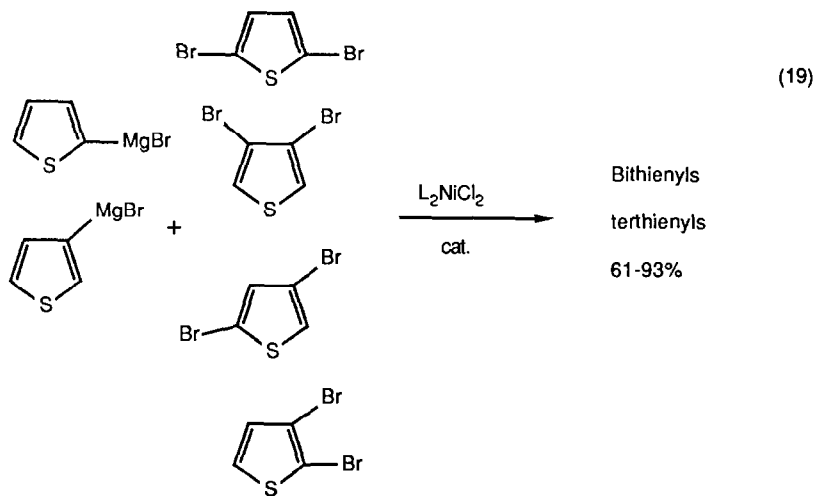
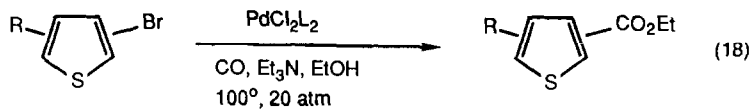

$\text{R} = \text{Me, iPr, tBu}$

$\text{R}' = \text{Me, Ph, CH}_2\text{Cl, pNO}_2\text{Ph,}$

$\text{R}'' = \text{H, Me}$



Palladium-catalyzed oxidative addition-transmetalation processes from tin, zinc and boron continue to evolve. The palladium catalyzed cross-coupling reactions of organotin reagents with organic electrophiles has been reviewed [22, 23]. Coupled pyridines and quinolines were prepared by this method (equations 22-24) [24]. Benzyl bromide was converted to ethyl benzene by this process (equation 25) [25].  $\alpha$ -Phenethyl bromide underwent the same reaction, but only in low yield. Aryl tins were coupled to aryl halides to give biaryls using palladium catalysts [26]. Heteroaromatics were arylated in a similar manner (equation 26) [27].

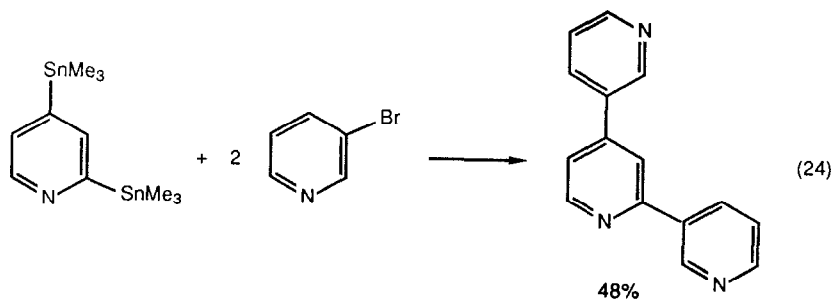
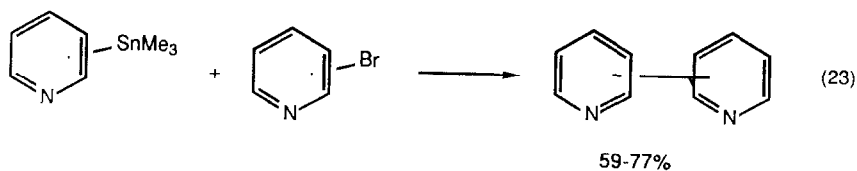
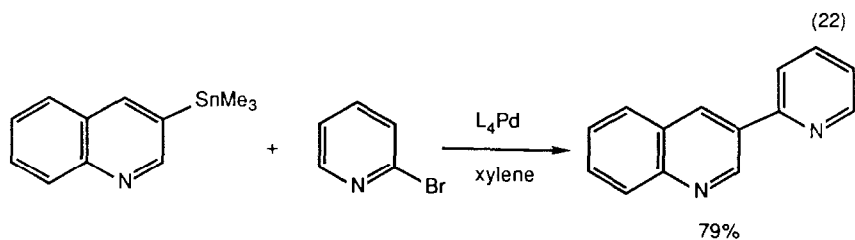

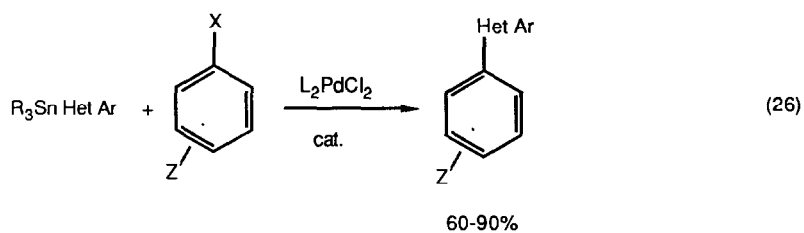
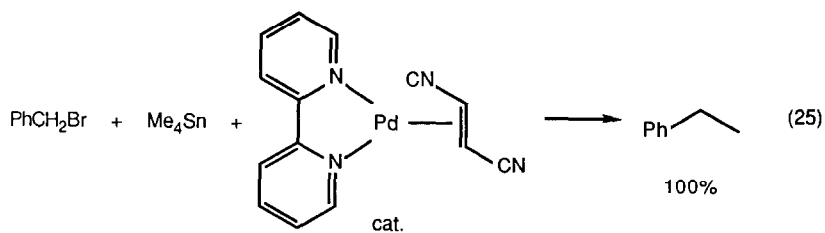

Z = Cl, OAc, H, CO<sub>2</sub>R

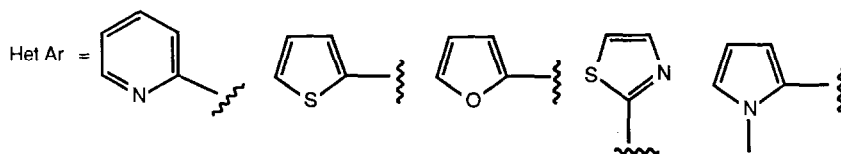

Vinyl triflates also underwent this palladium-catalyzed alkylation by tin reagents resulting in several useful synthetic transformations (equation 27) [28], (equations 28 and 29) [29], (equation 30) [30].

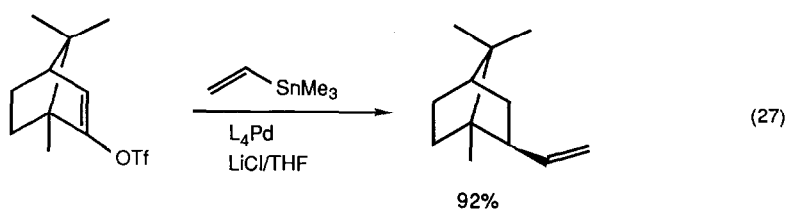

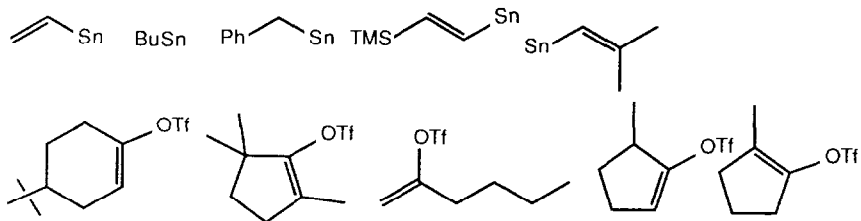
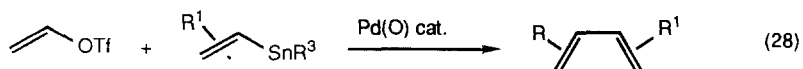

All work in good yield.

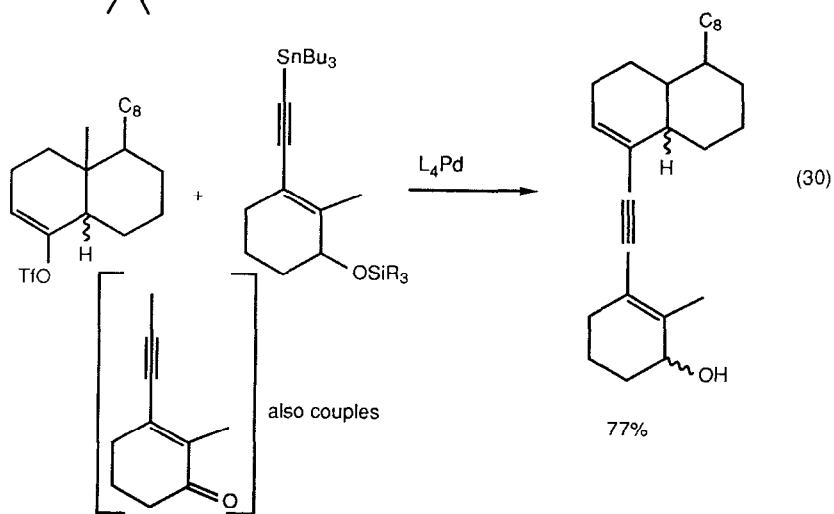
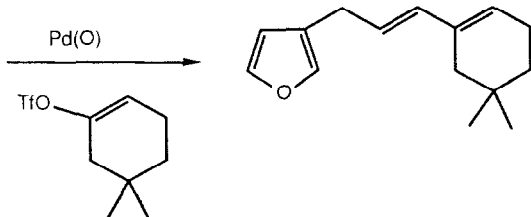
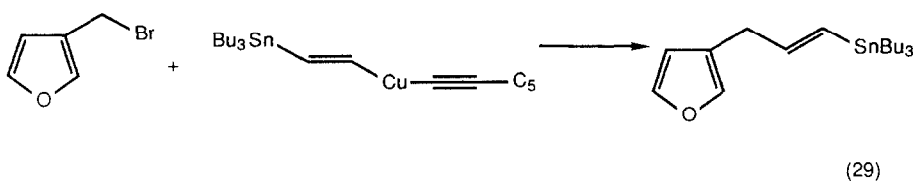

Palladium catalyzed the alkylation of vinyl (equation 31) [31], aryl (equation 32) [32] and allenic halides (equation 33) [33] by alkylzinc reagents. *Trans* vinyl halides (equations 34 and 35) [34] reacted in preference to *cis* vinyl halides, as did *trans* dibromoethenes (equation 36) [35]. Palladium also catalyzed the coupling of trifluorovinyl zinc reagents with aryl halides (equation 37) [36] and vinyl halides (equation 38) [37], and the coupling of alkynylzinc reagents with perfluoroalkyl iodides (equation 39) [38].

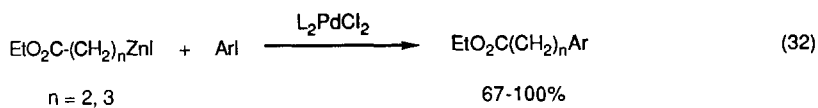
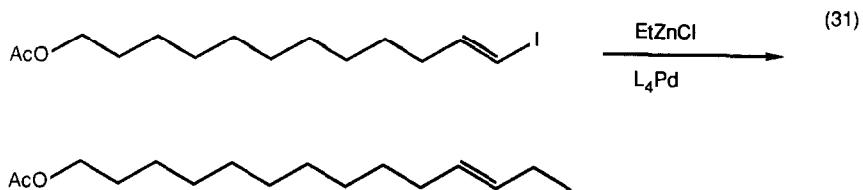

Ar = Ph, oMePh, pMeOPh, oMeO<sub>2</sub>XCPH, pBrPh, pNO<sub>2</sub>Ph

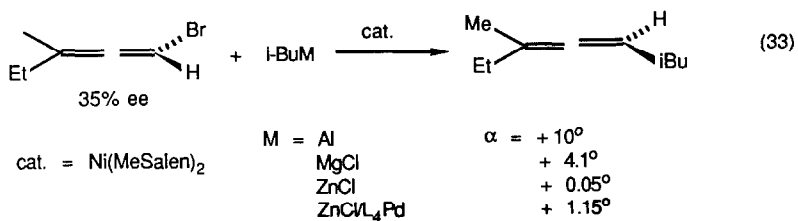
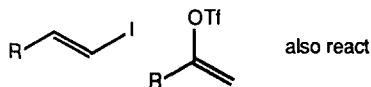

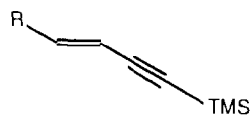
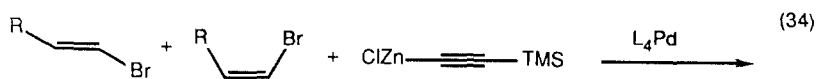

R = nBu, nPr, nC<sub>5</sub>

exclusively

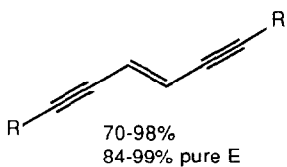
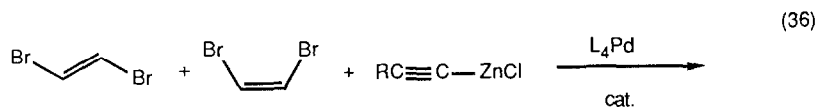
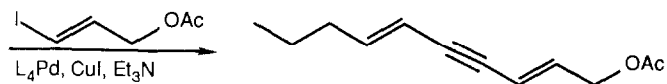
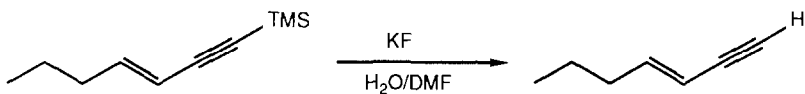

R = nBu, nC<sub>5</sub>, TMS, Ph

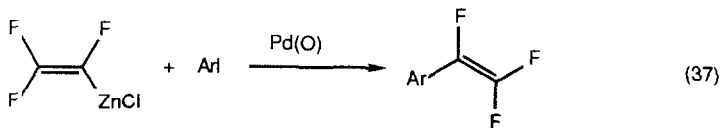

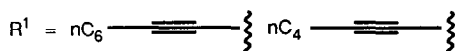
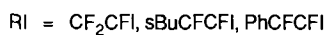
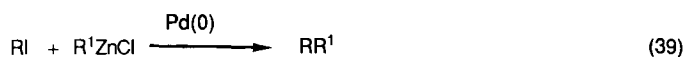
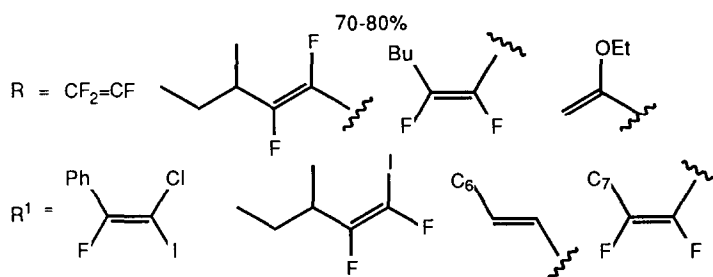

Palladium catalyzed the coupling of zinc homoenolates to aryl and acid chlorides (equation 40) [39]. Palladium also catalyzed the coupling of  $\alpha$ -lithiozinc reagents to a number of organic halides [40].

Palladium also catalyzed the alkylation of organic halides by vinyl boranes (equations 41 and 42) [41], (equation 43) [42], (equation 44) [43]. This process was used in the synthesis of natural products (equation 45) [44]. 4-Substituted indoles were prepared by thallation/transmetallation processes (equation 46) [45].

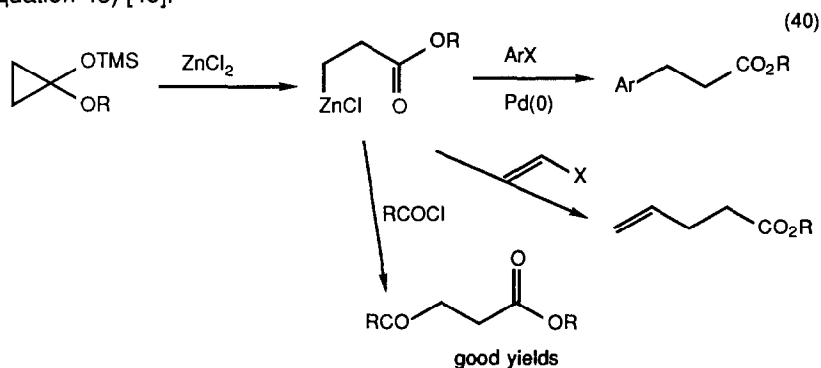

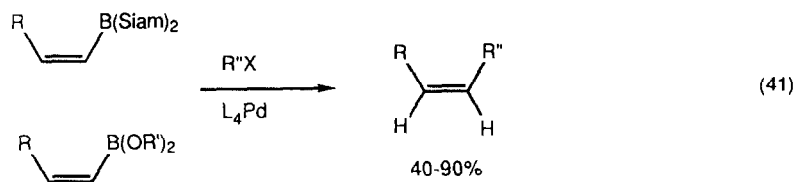

R = Bu

R' = Ph

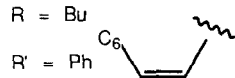

(42)

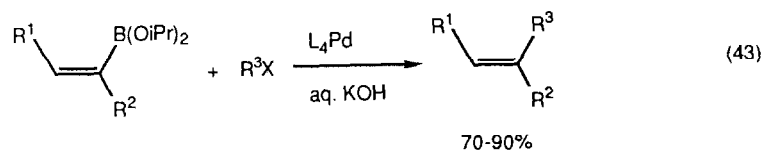
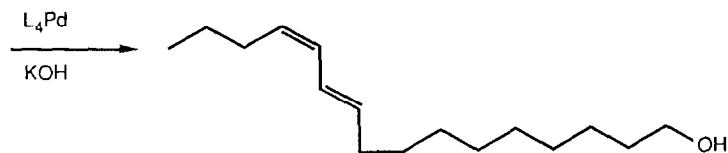
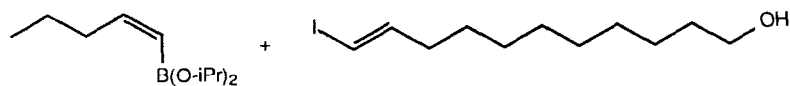
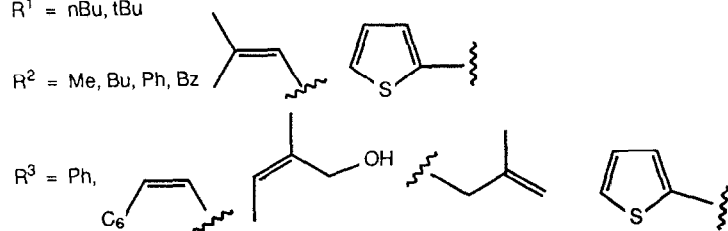
R<sup>1</sup> = nBu, tBuR<sup>2</sup> = Me, Bu, Ph, Bz



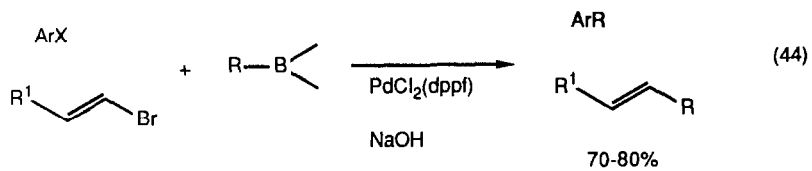

Ar = Ph, oMeOPh, pMeO<sub>2</sub>CPh, 1-Naphth

R = nC<sub>8</sub>, iBu

R<sup>1</sup> = Ph, Me<sub>2</sub>, nC<sub>6</sub>

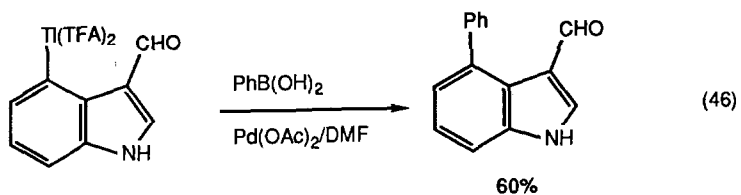
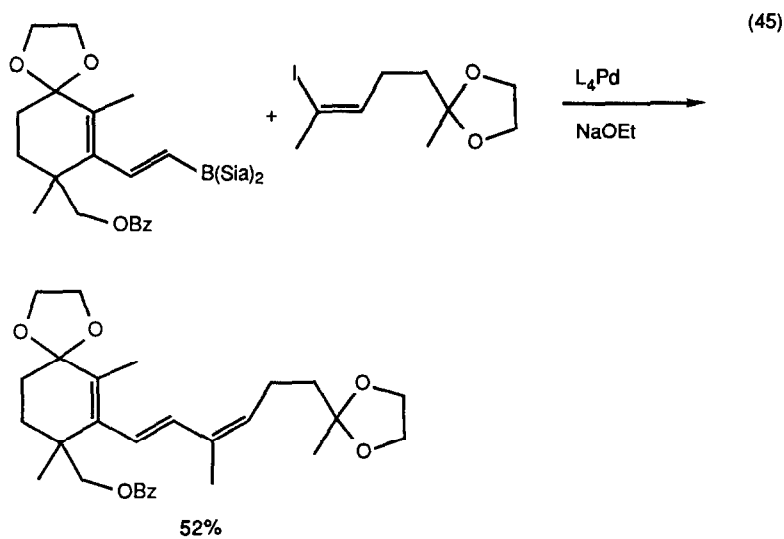

Palladium was used to catalyze the reactions of terminal acetylenes with aryl halides (equation 47) [46], (equation 48) [47], (equation 49) [48], (equation 50) [49], (equation 51) [50], with vinyl halides (equations 52 and 53) [51], with vinyl triflates (equation 54) [52], and with aryl triflates (equation 55) [53].

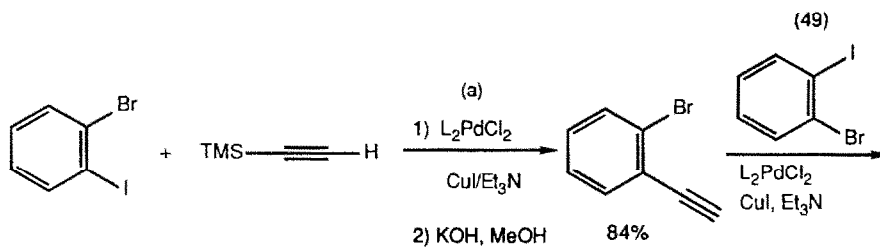
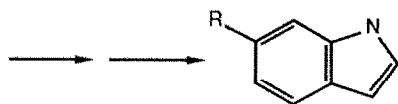
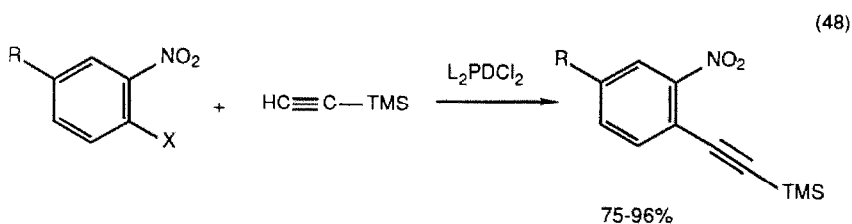
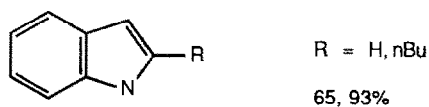
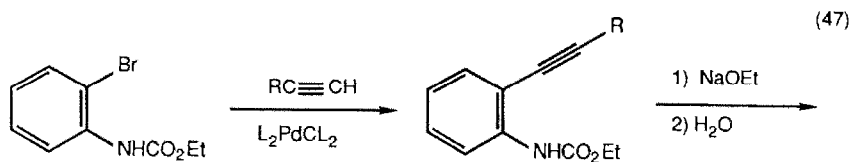

(equation 49 continued)

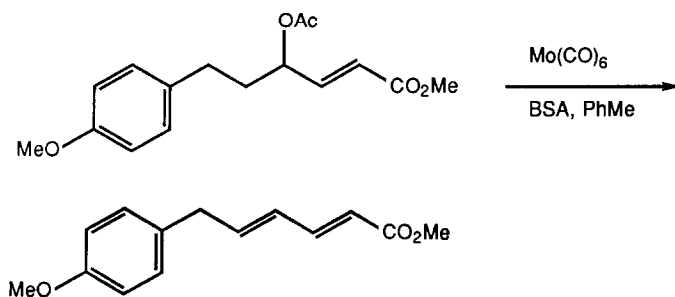
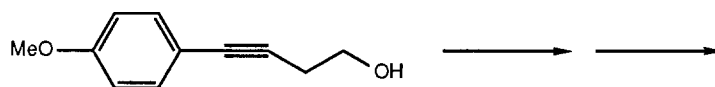
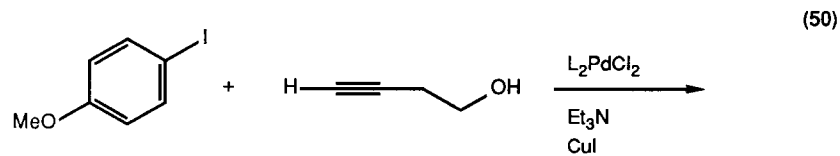
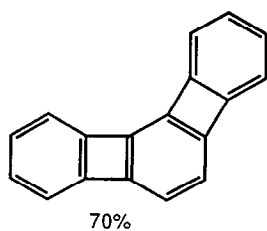
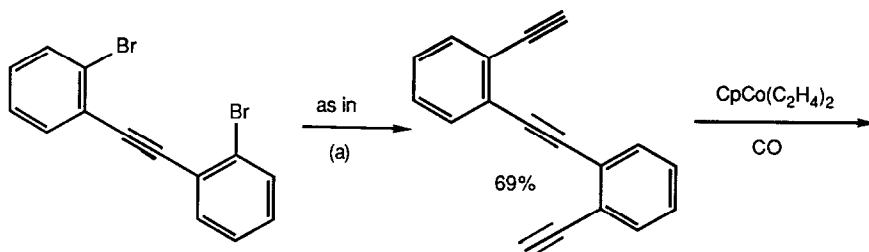

References p. 372

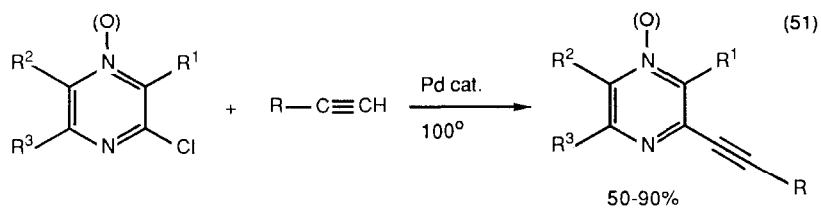

$R^1 = \text{Me, Et, iPr, iBu, Ph, H}$

$R^2 = \text{H, Ph}$

$R^3 = \text{Me, Et, iPr, iBu, Ph, H}$

$R = \text{Ph, Bu, CH}_2\text{OH}$

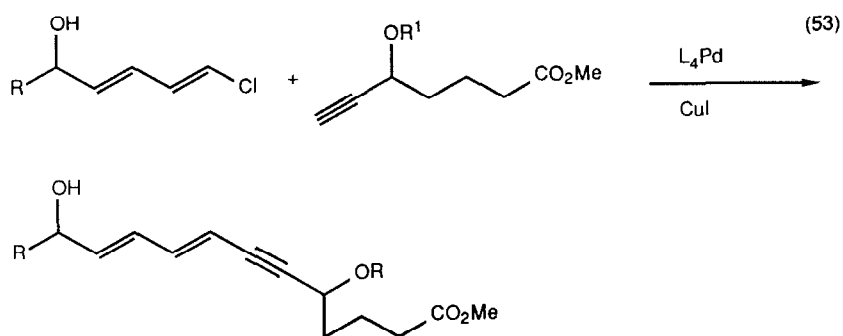
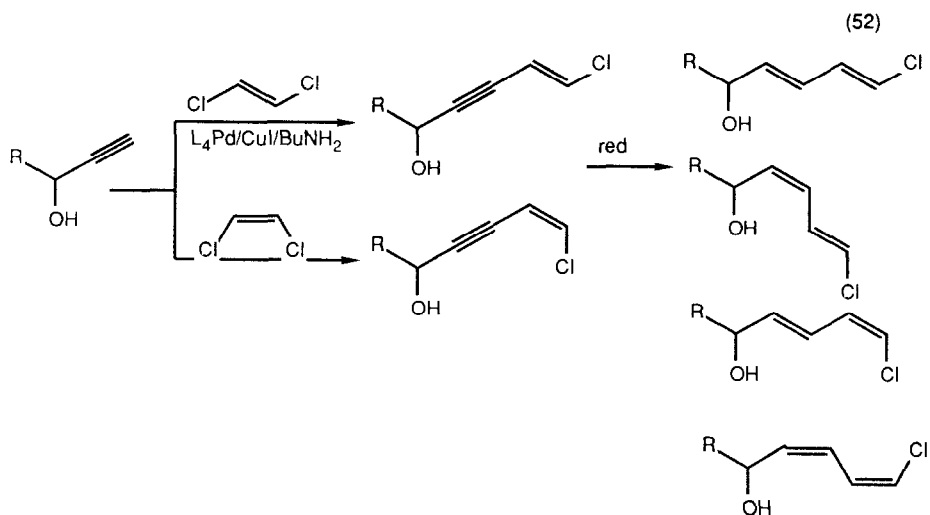

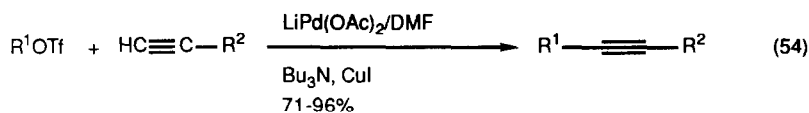

$R^1$  = enol triflates of steroidal ketones

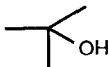
$R^2$  = Ph, tBu, TMS, (EtO)<sub>2</sub>CH, CO<sup>2</sup>Et, 

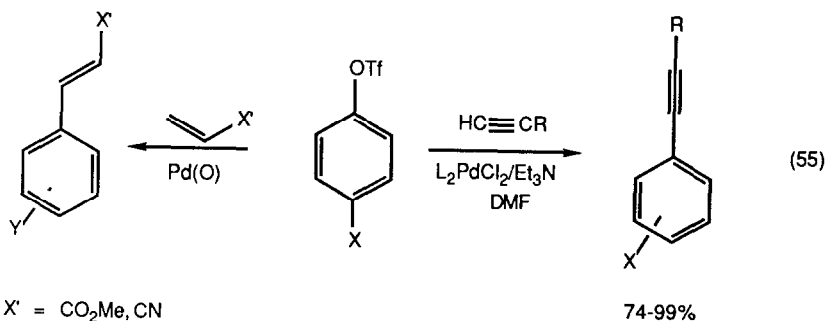

Nickel(O) cross coupling of benzyl halides gave cyclophanes [54]. Palladium-catalyzed cross coupling involving proximally heterofunctional reagents was the subject of a dissertation [55]. Group(VIII) metal-catalyzed carbon-carbon bond forming sequences has been reviewed [56]. Palladium(O) catalyzed the alkylation of amines by perfluoroalkyl iodides (equation 56) [57]. Copper assisted the alkylation of aryl halides by stabilized carbanions (equations 57 and 58) [58].

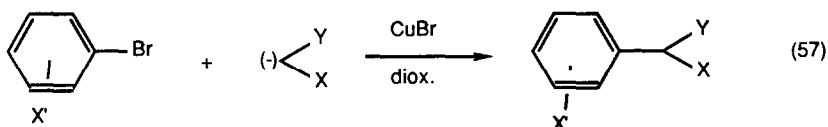
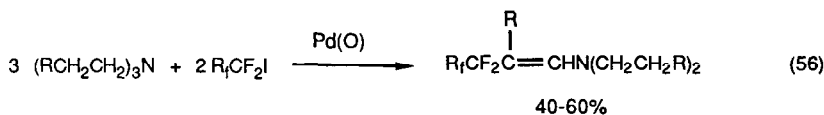

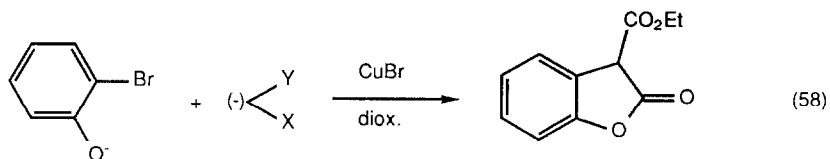

## 2. Alkylation of Acid Derivatives

Imidoyl chlorides were converted to imines by a palladium catalyzed reaction with alkyl tin reagents (equation 59) [59]. Conjugated enones were made by a palladium(O) catalyzed condensation of acid chlorides (equation 60) [60].  $\alpha$ -Cuprated zinc reagents alkylated acid chlorides (equation 61) [61]. Palladium(O) complexes catalyzed the alkylation of acid chlorides by vinyl copper species (from carbocupration of alkynes) (equations 62-65) [62].

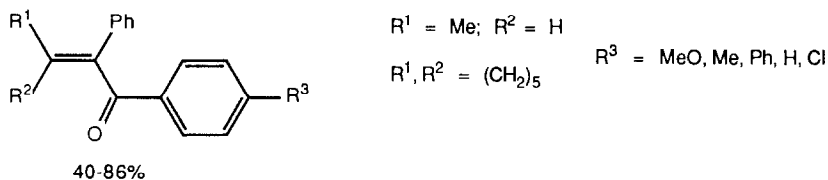
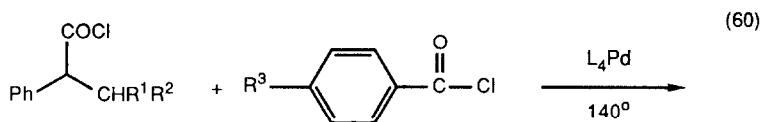
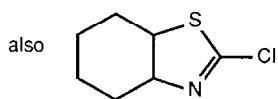
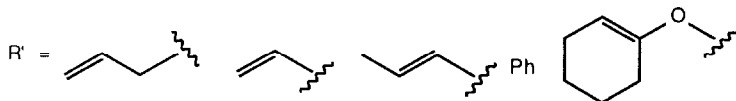
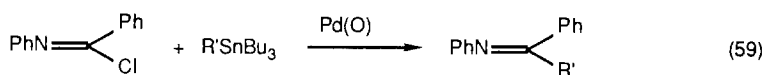

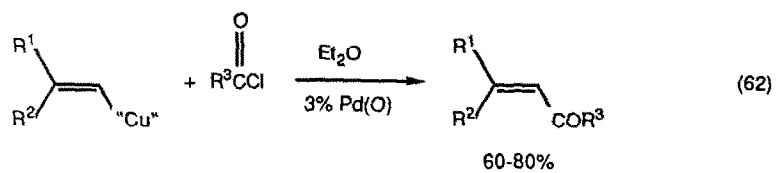
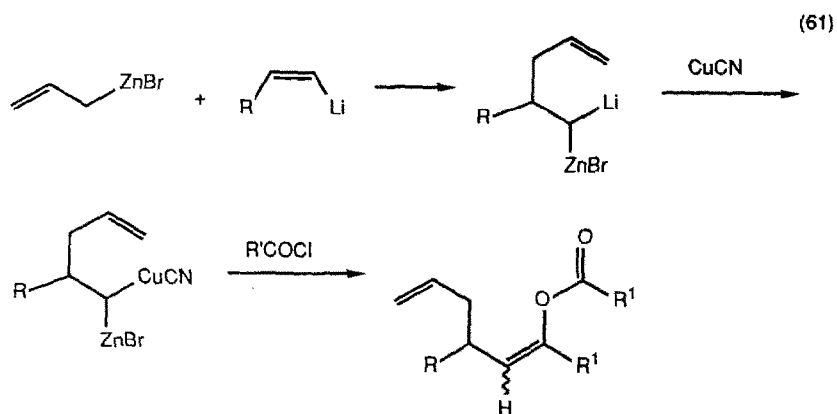

R<sup>1</sup> = H, Me, Et

R<sup>2</sup> = nC<sub>7</sub>, Et, nBu, iPr

R<sup>3</sup> = Me, nC<sub>7</sub>, Bu, tBu, Ph, OEt

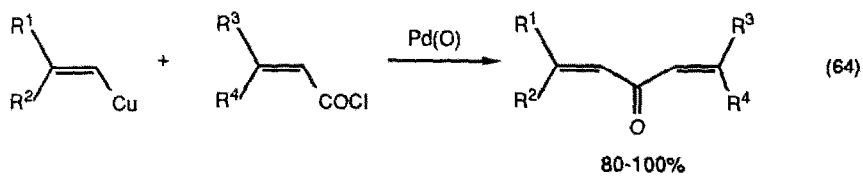
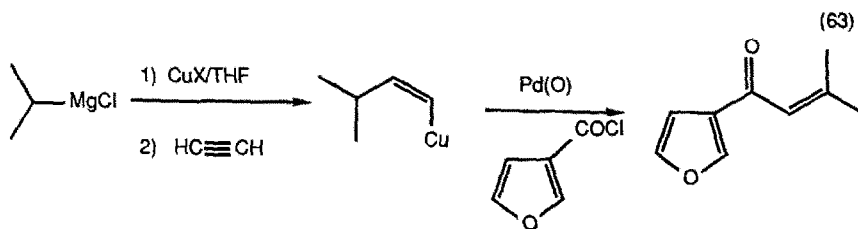





### 3. Allylation of Olefins

Palladium catalyzed oxidative addition/olefin insertion continues to be the method of choice for the arylation of olefins. Arylated butenolides were prepared via the palladium-catalyzed arylation of  $\omega$ -hydroxy-acrylates (equation 69) [66]. *o*-Bromoacetanitriles were olefinated under similar conditions (equation 70) [67], as were chloropyrazines (equation 71) [68]. Palladium also catalyzed the coupling of indoles with chloropyrazines (equation 72) [69].  $\beta$ -Trimethylsilyl styrenes were prepared by the palladium catalyzed arylation of vinyltrimethylsilene (equation 73) [70]. Conjugated enones were alkylated by vinyl triflates under palladium catalysis (equation 74) [71].

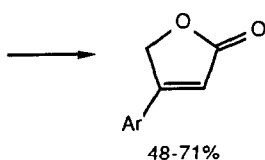
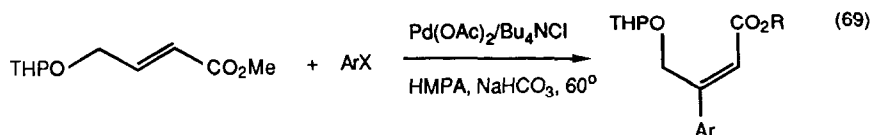

Ar = Ph, *p*MePh, *m*MePh, *p*MeOPh, *m*MeO<sub>2</sub>CPh, *m*HOCH<sub>2</sub>Ph, *p*BrPh

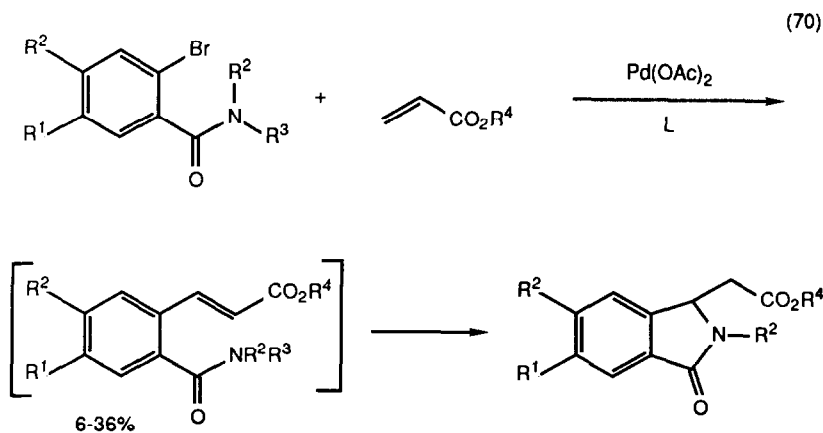

(equation 70 continued)

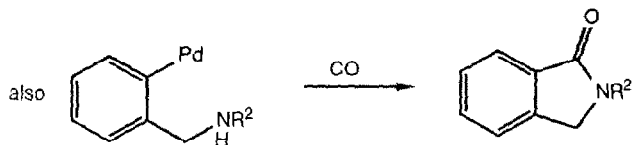

R<sup>1</sup> = OMe; R<sup>2</sup> = Me, Et, Ph, PhCH<sub>2</sub>, EtO<sub>2</sub>CCH<sub>2</sub>, CH<sub>2</sub>CH(OEt)<sub>2</sub>, 3,4(MeO)<sub>2</sub>Ph

R<sup>3</sup> = H, Et; R<sup>4</sup> = Me, Et

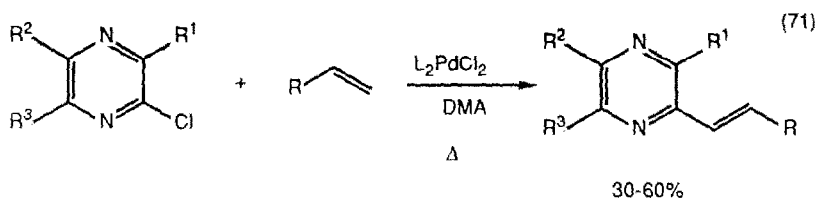

R<sup>1</sup> = Me, Et, iPr, iBu; R<sup>2</sup> = H, Ph; R<sup>3</sup> = Me, Et, iPr, iBu; R = Ph, CO<sub>2</sub>Et, CN

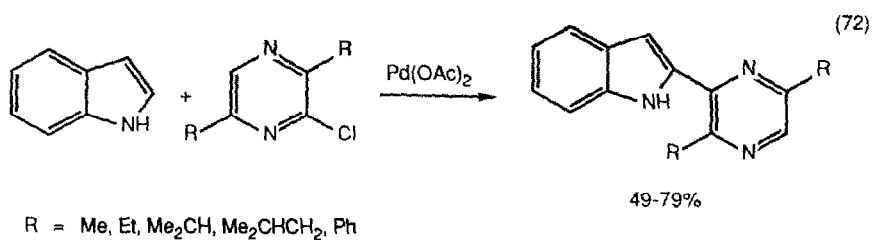
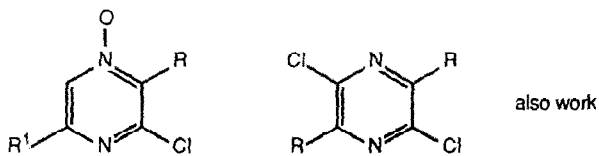

R = Me, Et, Me<sub>2</sub>CH, Me<sub>2</sub>CHCH<sub>2</sub>, Ph

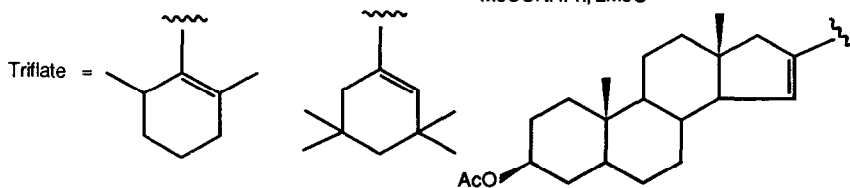
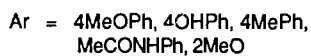
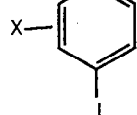
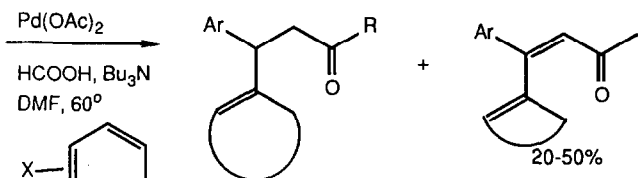
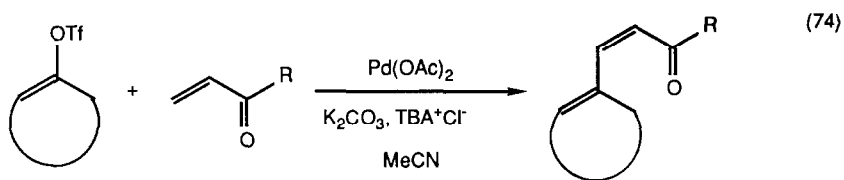
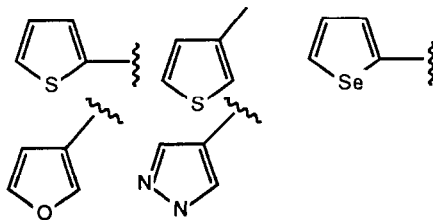
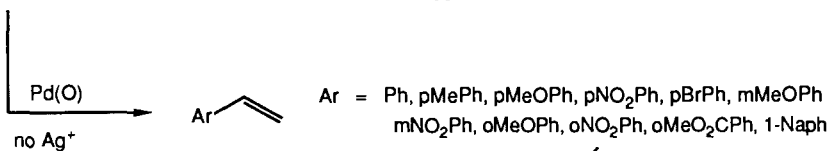
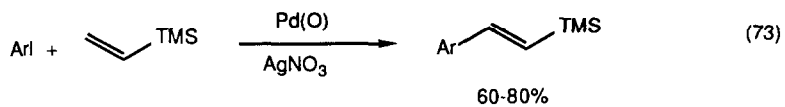

Electrogenerated low oxidation state nickel complexes catalyzed the coupling of ethylene to bromobenzene to give styrene in 70% yield [72]. Olefins were similarly arylated by aryl halides in the presence of nickel complexes and zinc (equation 75) [73]. Palladium catalyzed the arylation of styrene by diaryliodonium salts, to give stilbene [74]. Palladium also catalyzed the cyclization shown in equation 76 [75].

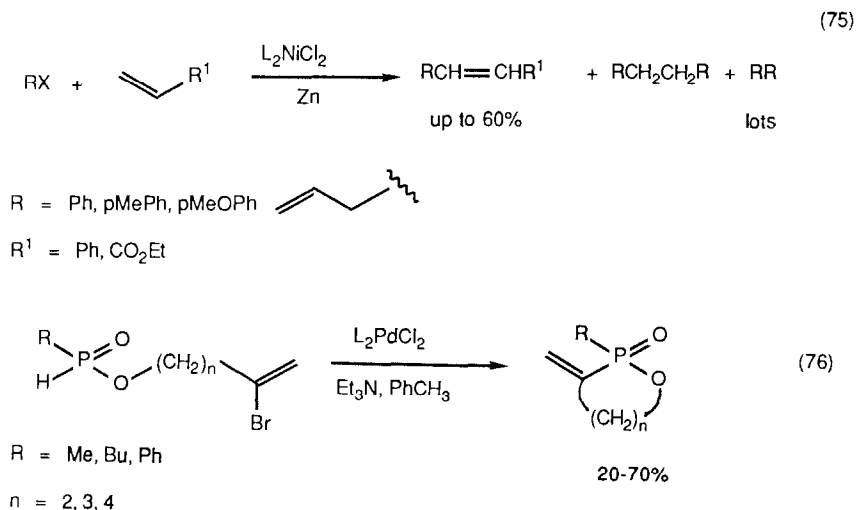

Palladium also catalyzed a number of transmetalation/insertion processes which resulted in the alkylation of olefins. This was particularly useful in the coupling of mercurated pyrimidines with sugars (equations 77 and 78) [76], (equation 79) [77]. Norbornene was alkylated by vinyl mercuric halides under palladium catalysis and the resulting  $\sigma$ -alkylpalladium complex was further transformed (equation 80) [78], (equation 81) [79]. Norbornadiene underwent similar reactions (equation 82) [79]. Indoles were vinylylated in the 4-, 5-, and 7-position in a thallation/palladation insertion sequence (equation 83) [80], (equation 84) [81]. Methyl vinyl ketone was arylated by arylthallium salts using palladium catalysis (equation 85) [82].

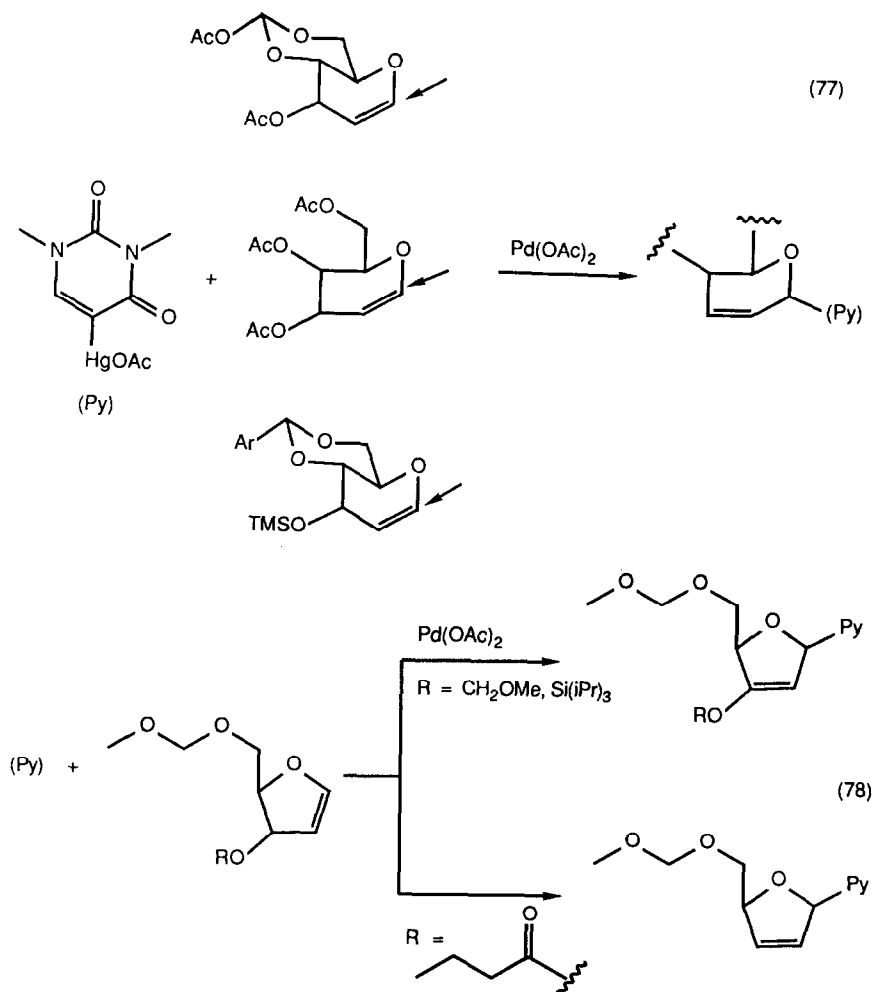

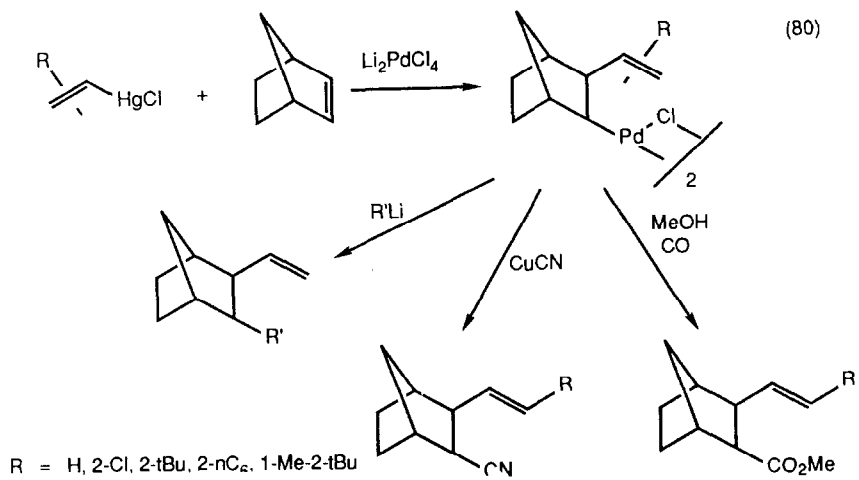
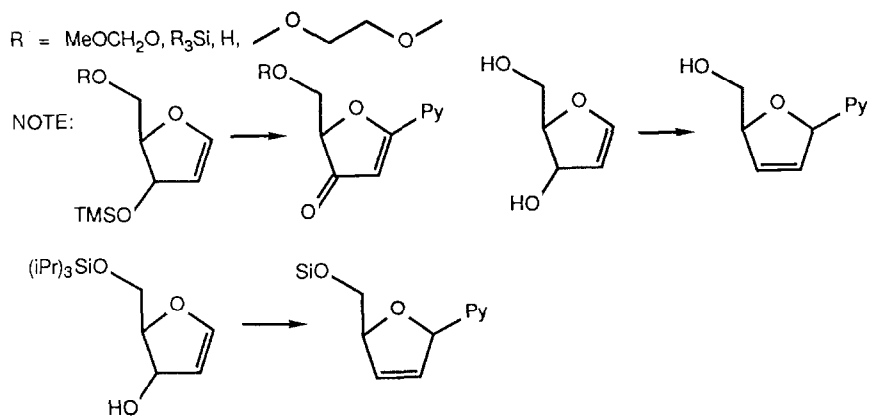
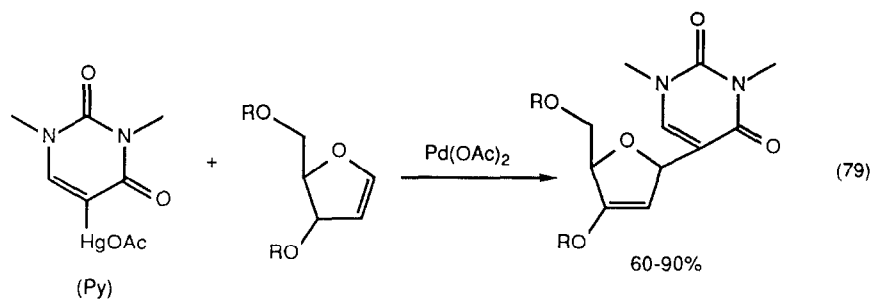

(equation 80 continued)

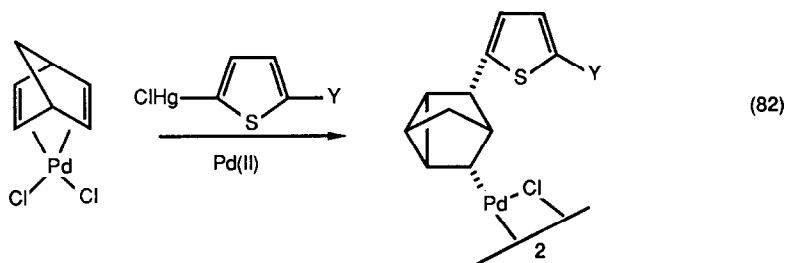
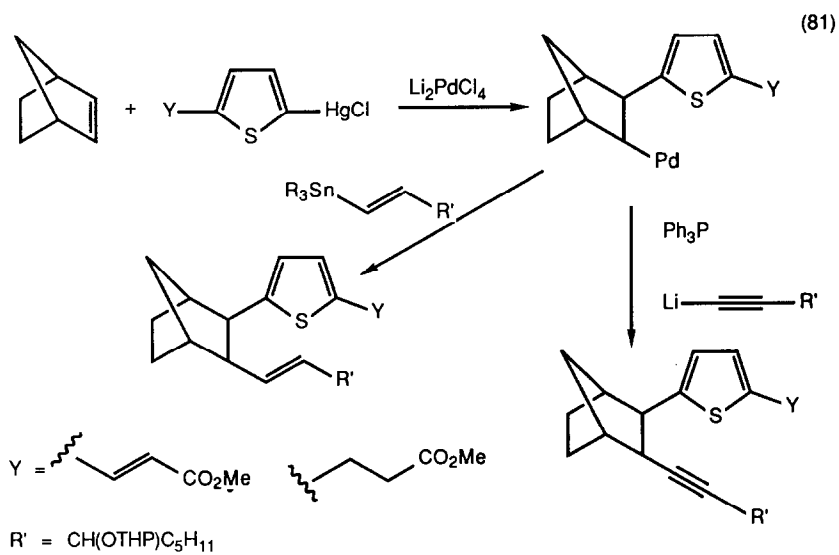
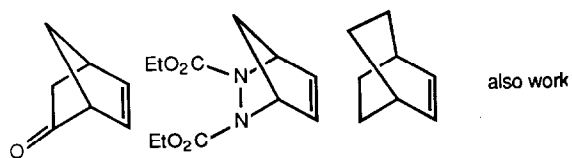

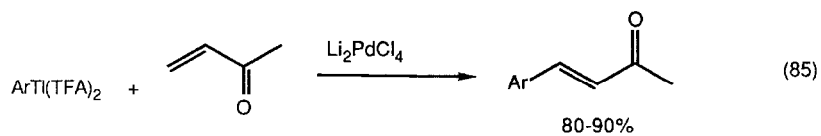
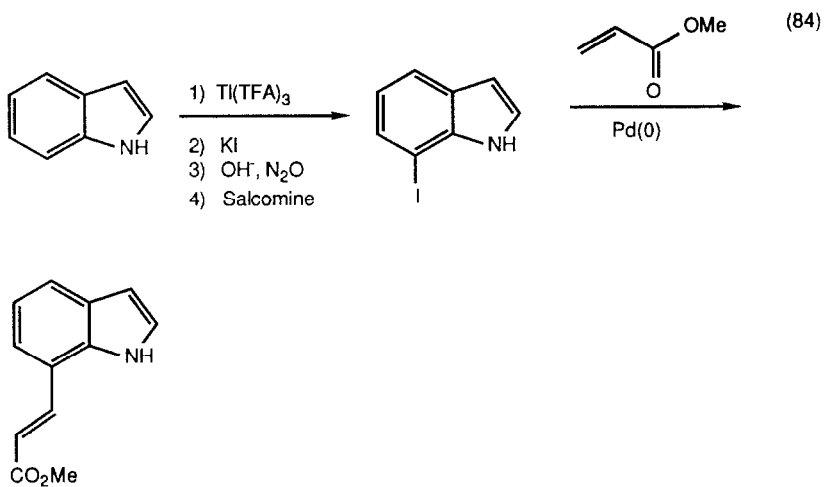
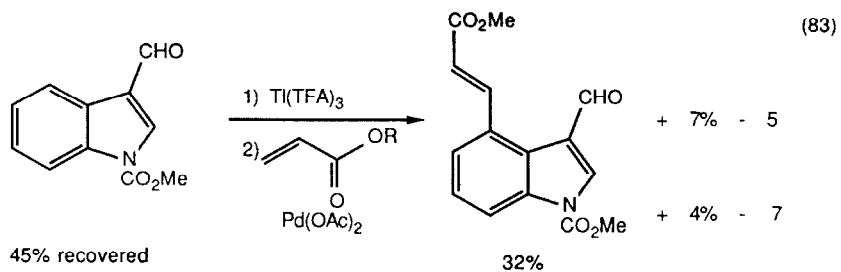

Ar = Ph, pTol, Mes, pMeO, pClPh



Direct aromatic palladation (equation 86) [83], or orthopalladation (equation 87) [84] followed by olefin insertion also served to arylate olefins. Ortho-ruthenated phosphites underwent a similar olefination (equation 88) [85]. Zirconocene dichloride catalyzed the ethylation of norbornene, dicyclopentadiene, and norbornadiene by ethylmagnesium chloride [86].

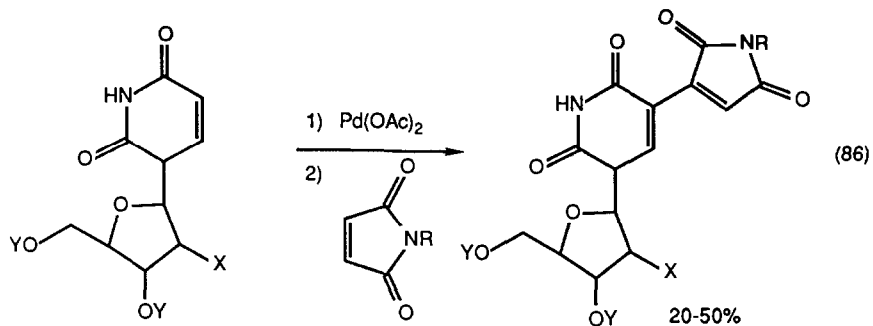

X = OH, OAc, H

Y = H, OAc

R = H, Me, Et, Ph, Bz

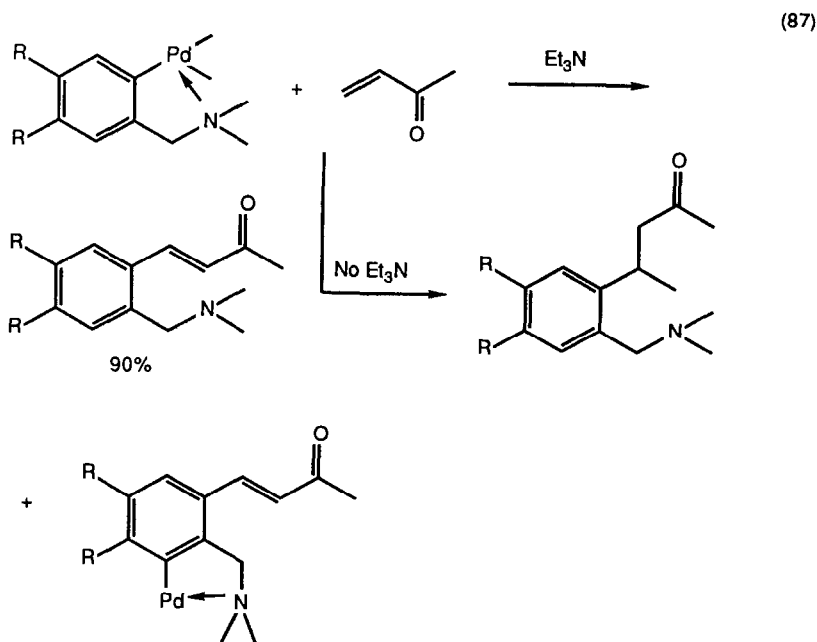

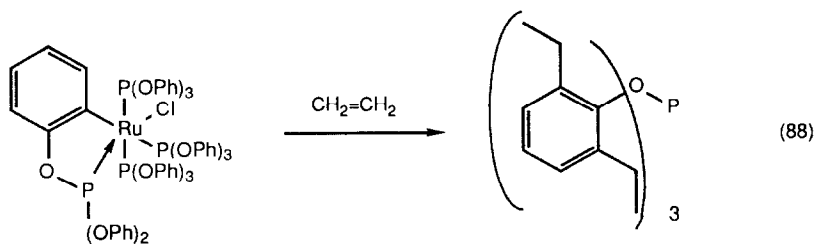

Raney nickel catalyzed the addition of perfluoroalkyl iodides to olefins (equation 89) [87] as did palladium(O) (equation 90) [88,89], and platinum(O) [90]. The copper catalyzed additions of organic polyhalides to olefins has been reviewed [91]. Copper(I) catalyzed the addition of trifluorochloroethene to conjugated dienes [92].

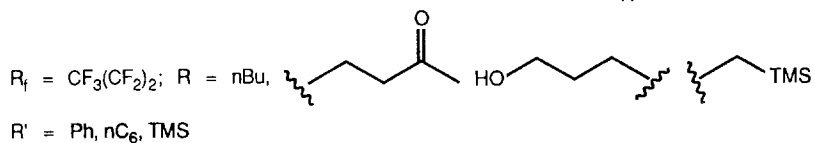
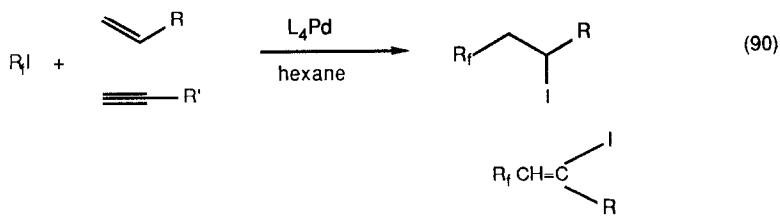
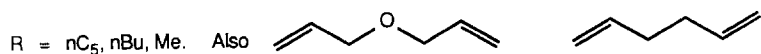
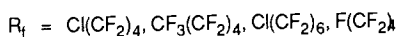
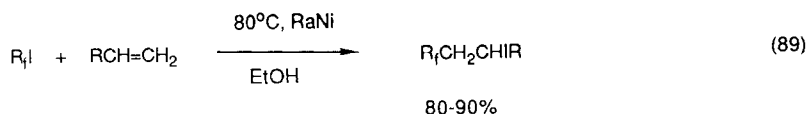

Olefins were alkylated by trimethylsilylenol ethers in the presence of palladium acetate (equation 91) [93]. Elimination was sometimes observed (equation 92). Palladium(II) salts catalyzed the aryl chlorination of unsaturated alcohols (equation 93) [94]. A number of metal catalysts cyclized  $\omega$ -olefins dichloroesters probably by radical processes (equations 94-96) [95]. Rhodium(I) complexes catalyzed the alkylation of butenoic acid by methylenecyclopropanes (equation 97) [96]. Iron(0) complexes catalyzed the alkylation of allyl ethers by dienes (equation 98) [97].

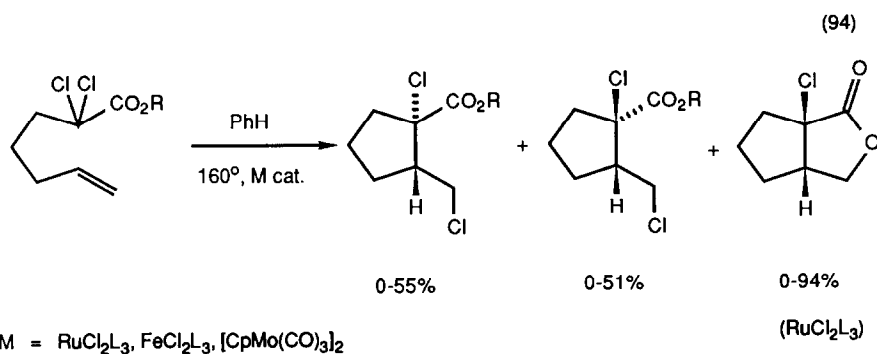
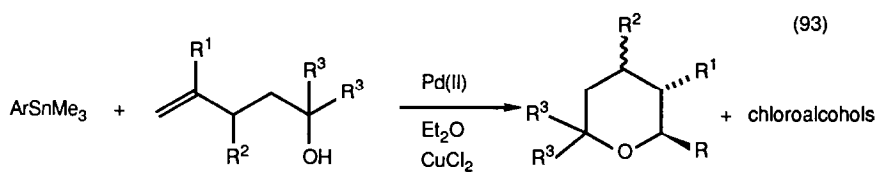
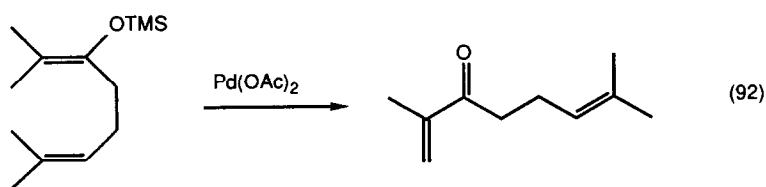
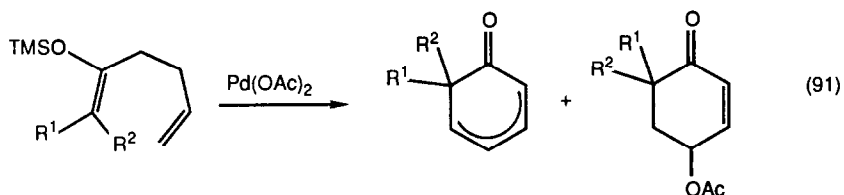

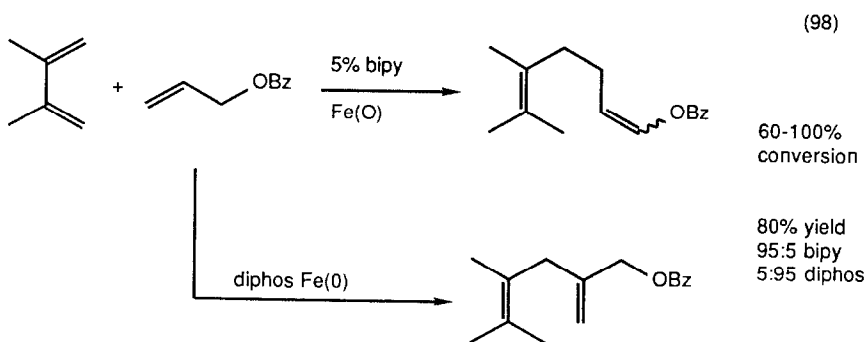
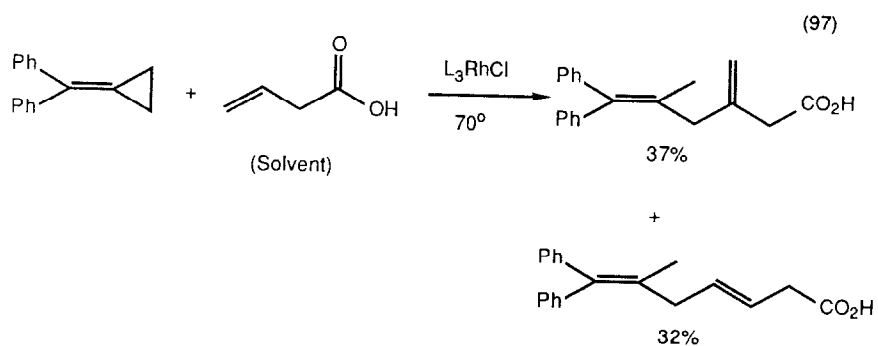
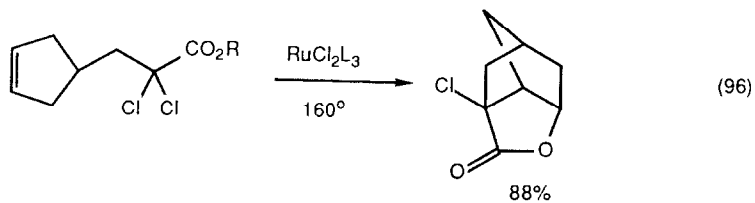
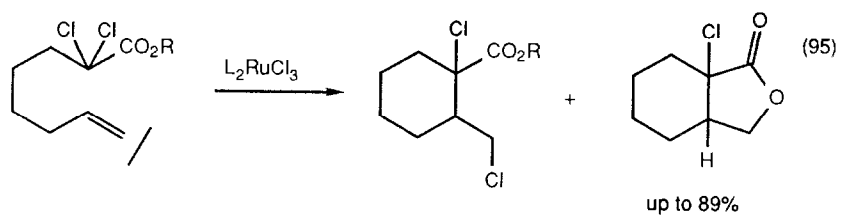

#### 4. Decomposition of Diazoalkanes and Other Cyclopropanations

Transition metals catalyze a number of useful insertion reactions of diazocompounds. Rhodium(II) acetate catalyzed insertion into O-H bonds to form cyclic ethers (equation 99) [98]. Copper(II) catalyzed the insertion of diphenylcarbene into N-H bonds (equation 100) [99]. Rhodium(II) acetate catalyzed a number of insertions into C-H bonds that produced useful organic compounds (equation 101) [100], (equation 102) [101], (equation 103) [102]. Polyfunctional systems were converted into polycyclic systems (equations 104 and 105) [103]. Palladium(II) also catalyzed the C-H insertion reactions of diazoalkanes (equations 106 and 107) [104].

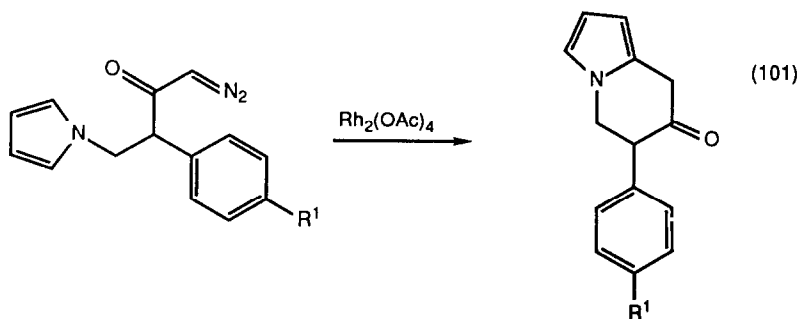
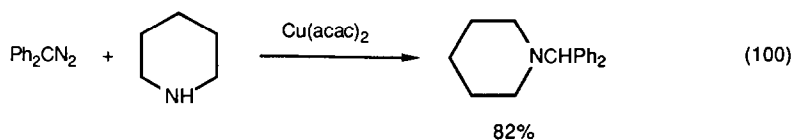
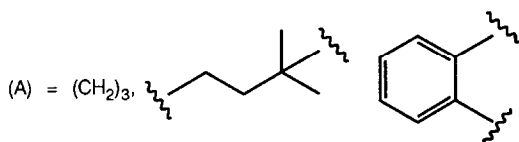
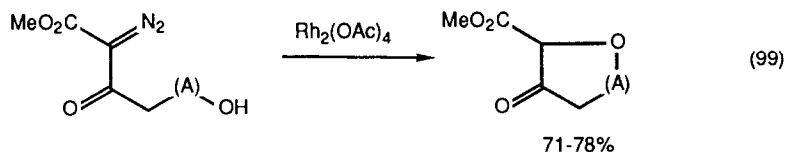

(equation 101 continued)

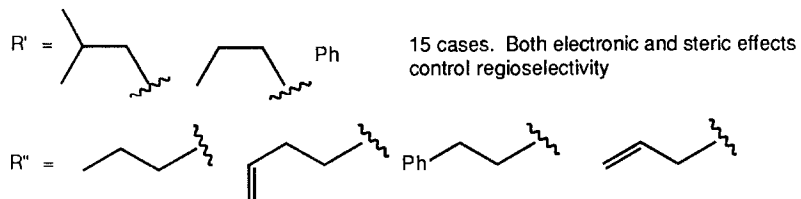
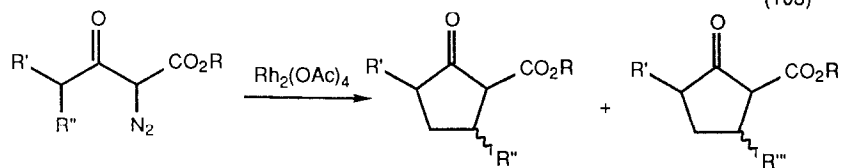
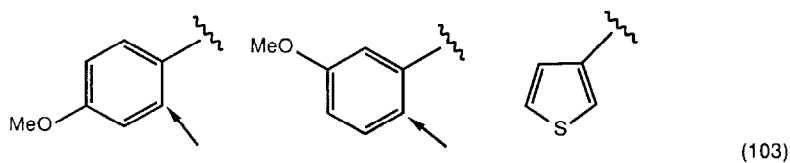
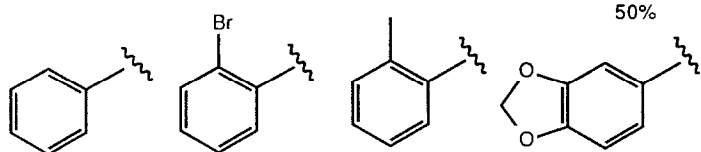
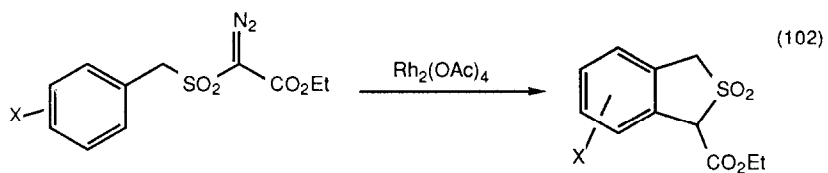
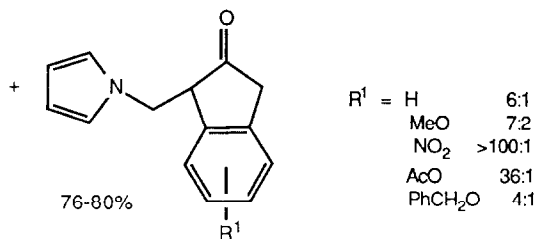

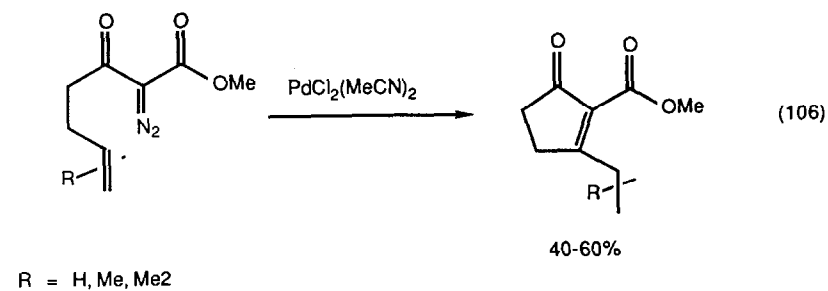
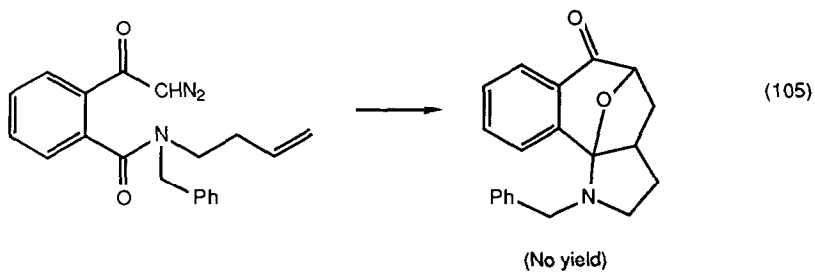
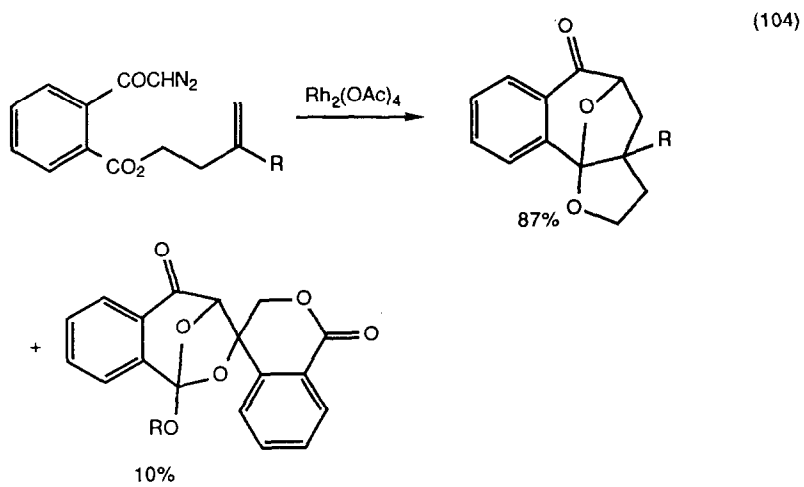

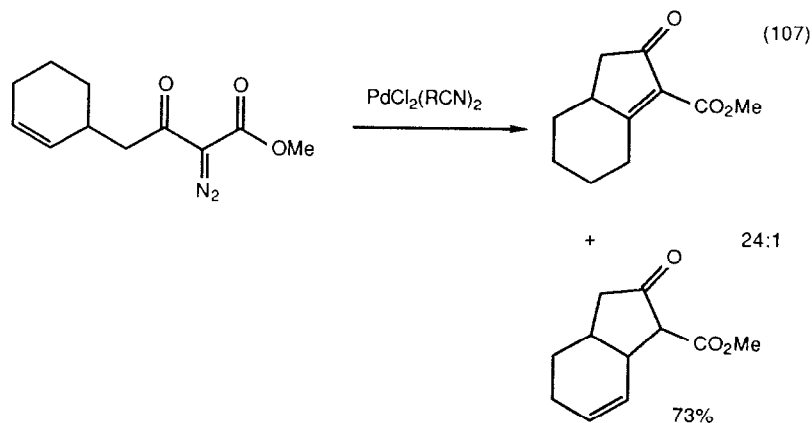

"Catalytic asymmetric synthesis of cyclopropanecarboxylic acids: an application of chiral copper carbenoid reaction" was the title of a review [105,106]. Chiral copper complexes catalyzed the cyclopropanation of olefins by diazocompounds in up to 97% ee (equation 108) [107]. Copper-loaded X-type zeolites catalyzed the same process, giving only small amounts of polymer, and with the same stereoselectivity of free copper catalysts. However only low asymmetric induction was observed [108]. Copper(I) chloride catalyzed the cyclopropanation of cyclooctatetraene to give all possible mono, di, tri and tetracyclopropanated products [109]. Rhodium(II) acetate catalyzed the cyclopropanation of olefins by diazoamides (equation 109) [110] and diazomalonates (equation 110) [111]. Polycyclic systems were prepared by the intramolecular cyclopropanation of enol ethers (equations 111-113) [112], (equations 114 and 115) [113].

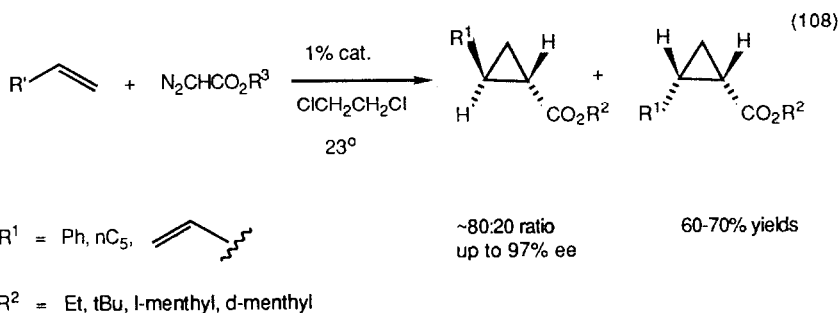



(equation 108 continued)

cat. =

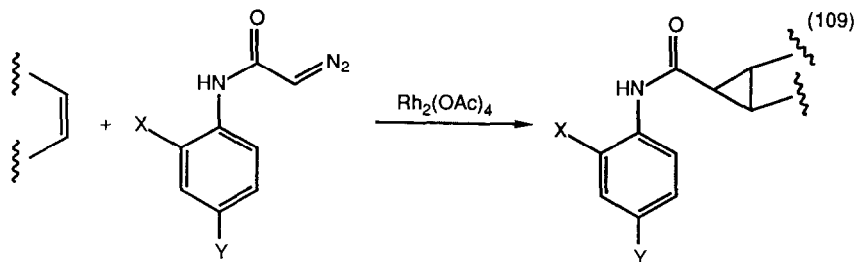
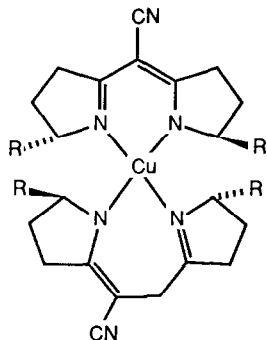

X, Y = H; X = H; Y = N<sub>3</sub>; X = OR; Y = N<sub>3</sub>

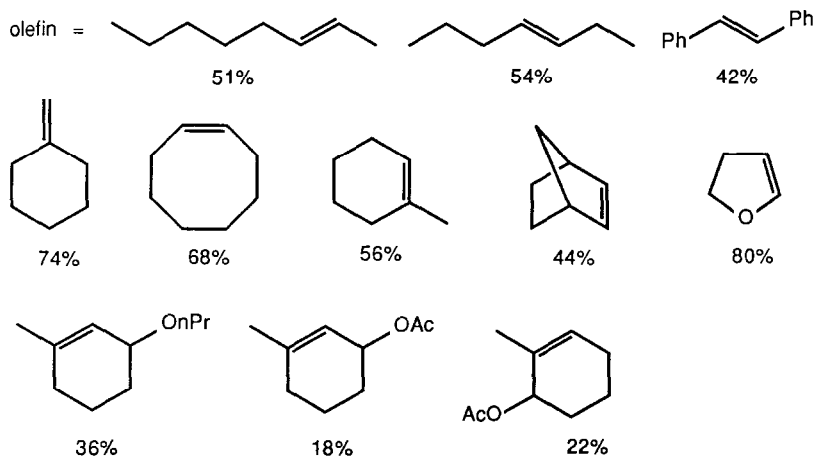

References p. 372

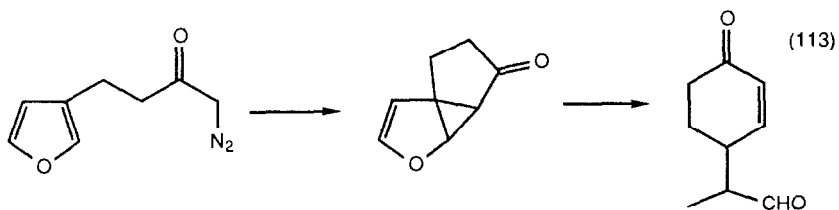
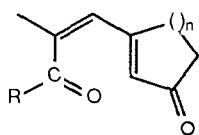
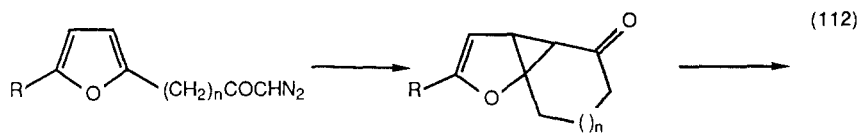
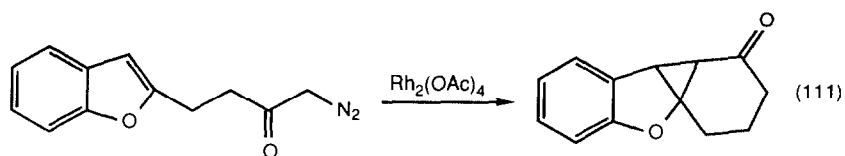
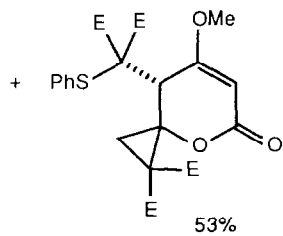
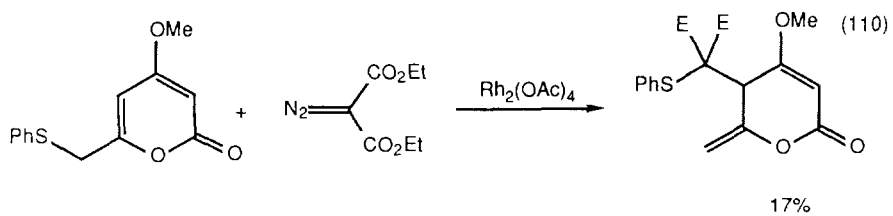

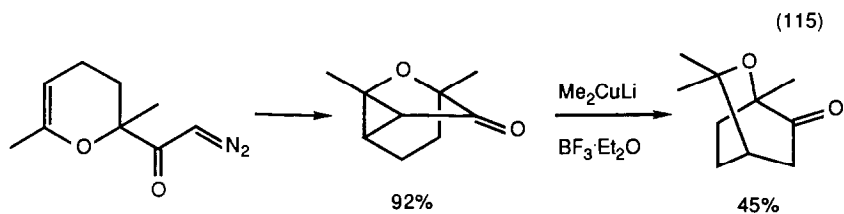
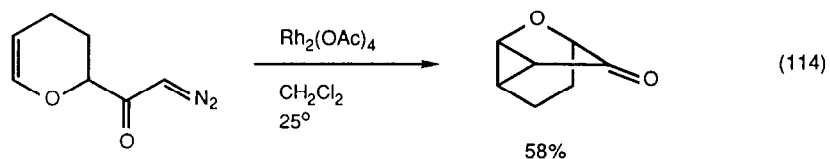

Palladium catalyzed the arylation of vinyl stannanes (equation 116) [114] and vinyl silanes (equation 117) [115] by arenediazonium salts. Titanium(III) salts catalyzed a similar process (equation 118) [116]. Olefins were prepared by the routine of Wittig reagents with diazo compounds via molybdenum intermediates (equation 119) [117].

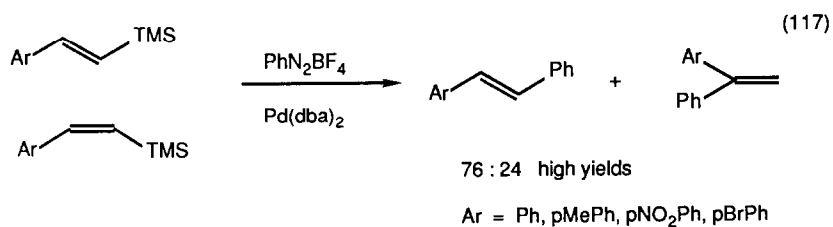
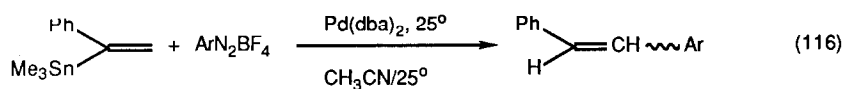

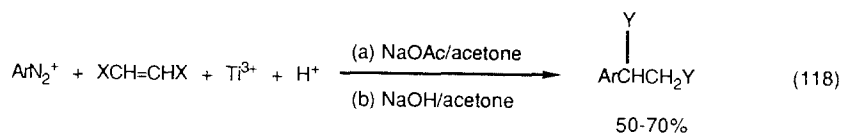

X = CO<sub>2</sub>H, CN, CONH<sub>2</sub>, CO<sub>2</sub>Et

Ar = Ph, pClPh, mClPh, oClPh, pMeOPh, pBrPh, pFPh

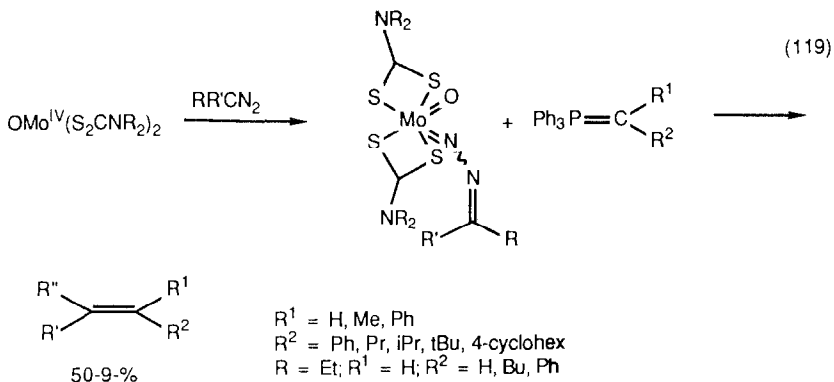

## 5. Cycloaddition Reactions

"[3+2] Cycloaddition approaches to five-membered rings via trimethylenemethane and its equivalents" has been reviewed (99 references) [118]. Palladium catalyzed generation of complexed trimethylene methanes has been used to synthesize a number of cyclic systems including silylated cyclohexanones (equation 120) [119]. With additional TMS functionality the system could be further functionalized (equations 121 and 122) [120]. This chemistry was used in the synthesis of (+)-brefeldin A (equation 123) [121], and other cyclic systems involving chiral auxiliaries (equations 124-126) [122]. Substituted cyclopentadiene having exocyclic double bonds were prepared by cycloaddition-cycloreversion processes (equation 127) [123]. Cycloadditions of trimethylene methane complexes to imines (equation 128) [124] and aldehydes (equation 129) [125] has also been developed.

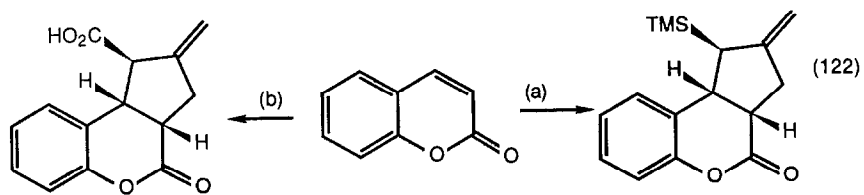
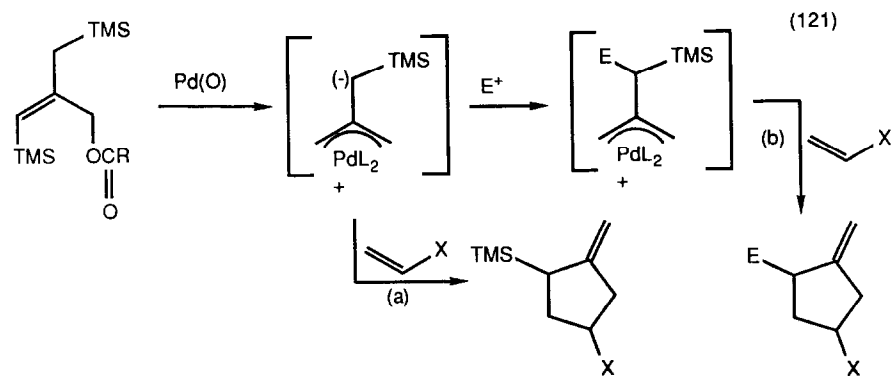
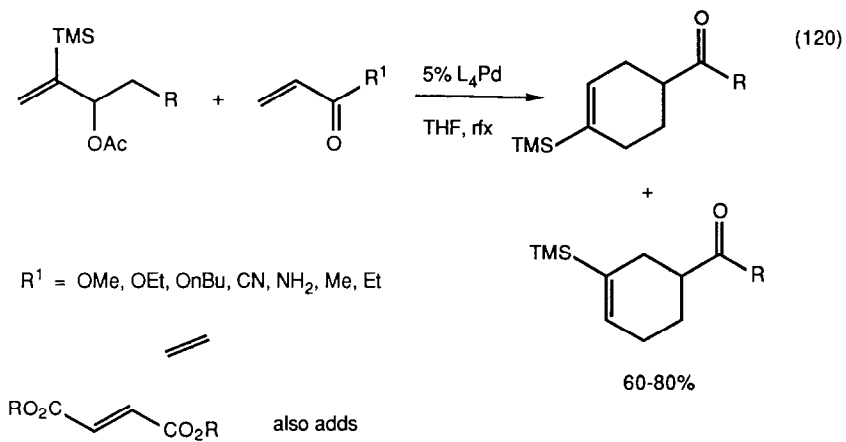

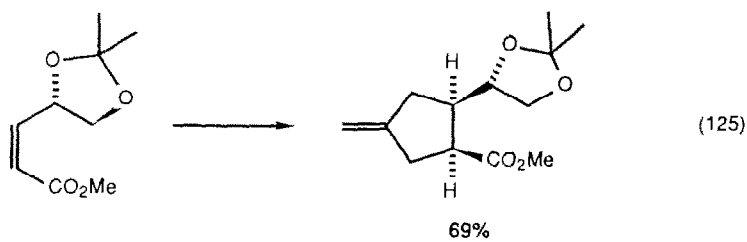
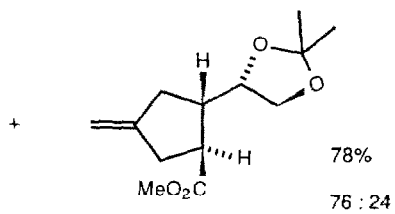
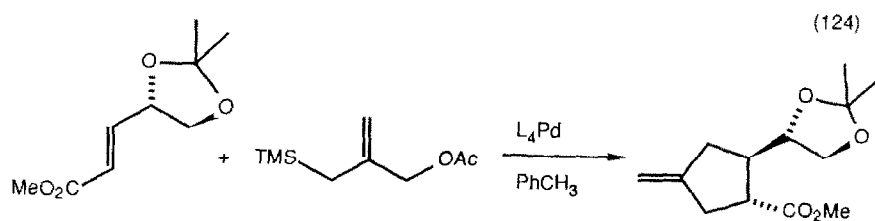
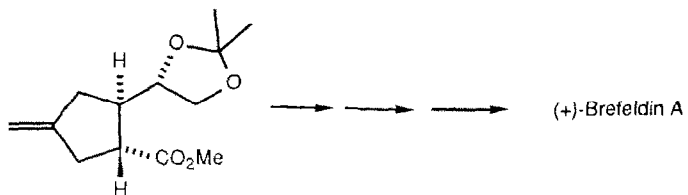
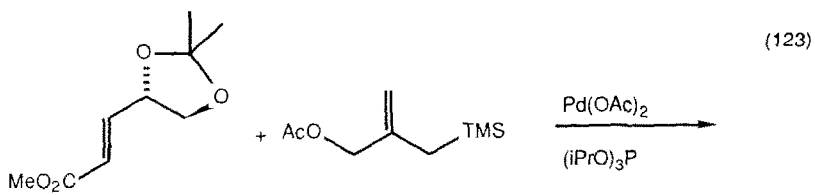

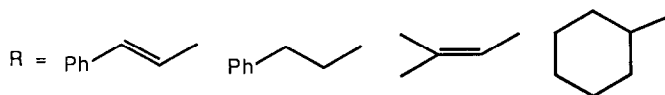
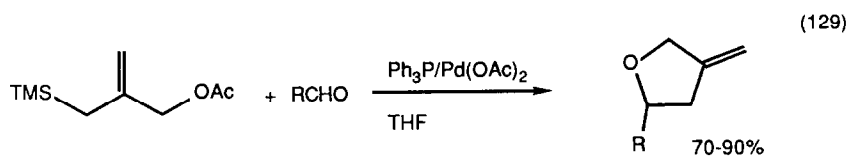
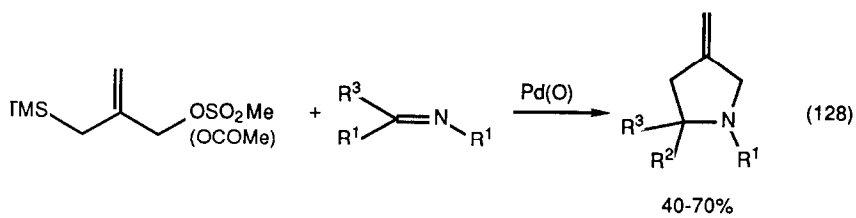
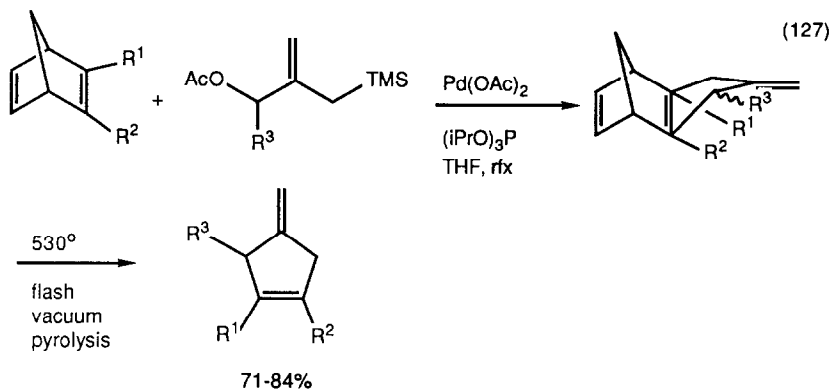
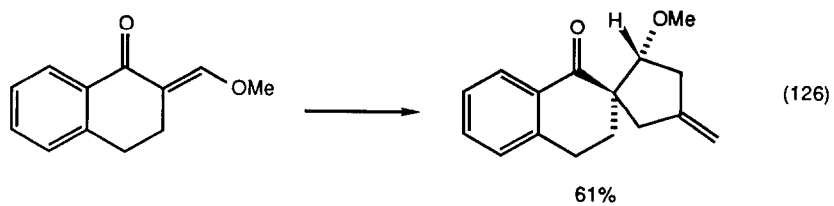

Aminated norbornenes were prepared in a sequence involving cycloaddition to  $\eta^1$ -cyclopentadienyliron complexes (equation 130) [126]. Metal-mediated cycloaddition reactions of 1,2-disilacyclobutenes with dienes has been reviewed (16 references) [127]. Metallo-1,3-dipoles underwent cycloaddition N-phenylmaleimide (equation 131) [128].

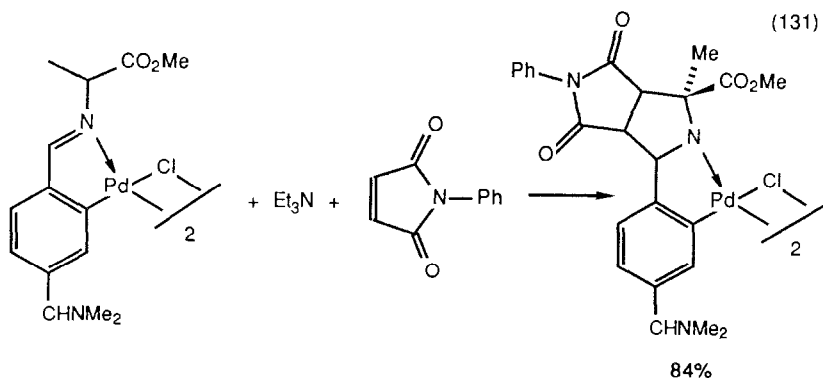
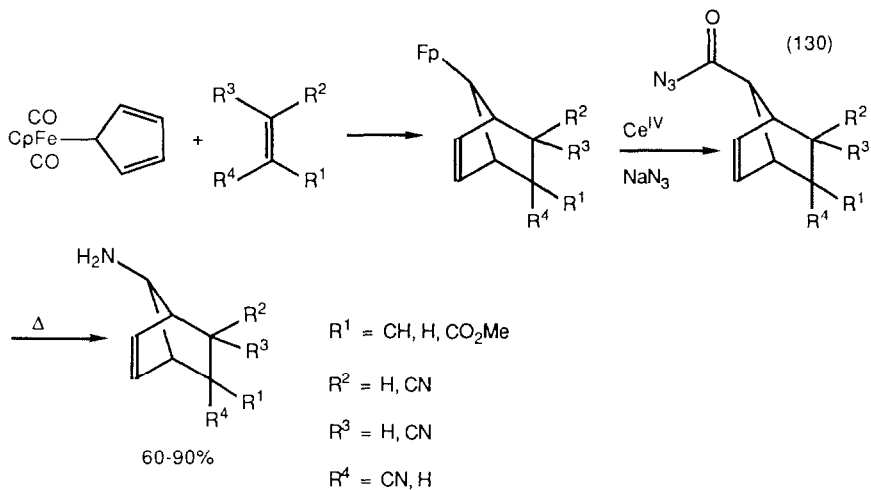



## 6. Alkylation of Alkynes

Trimethylsilylcuprates added to alkynes to give vinylcuprates (equation 132) [129]. Palladium and nickel salts catalyzed the addition of trimethylsilylcyanide to allenes (equation 133) [130]. Hexamethylditin added to alkynes in the presence of palladium(0) catalysts (equation 134) [131]. Trimethylsilylacetylenes were arylated by aryl iodides in the presence of palladium catalysts (equation 135) [132]. Palladium(II) catalyzed the cyclization of 1-cyclopropyl-2-propynyl acetates (equation 136) [133].

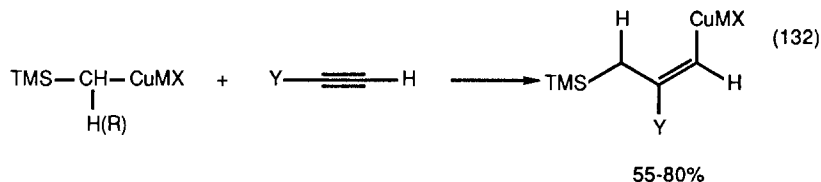

Y = nBu, OEt, CH(OEt)<sub>2</sub>, CO<sub>2</sub>Et, CH<sub>2</sub>OMgBr

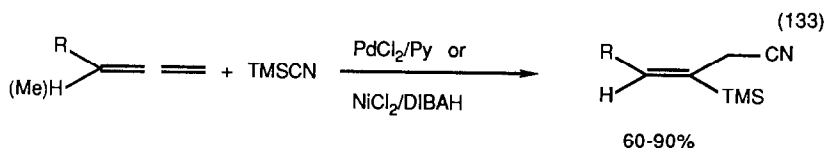

R = nC<sub>6</sub>, Ph

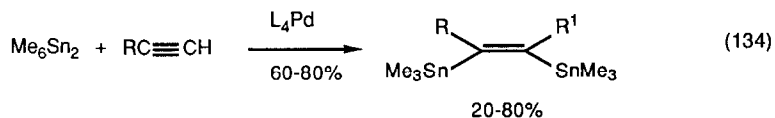

R = H, nBu, Ph, Bz, HOCH<sub>2</sub>, MeOCH<sub>2</sub>, PhOCH<sub>2</sub>, Me<sub>2</sub>NCH<sub>2</sub>, HOCH<sub>2</sub>CH<sub>2</sub>, HO-C<sub>6</sub>H<sub>11</sub>  
 HOCH(nPr), HOCMe<sub>2</sub>, HOCMeEt, HOC(Me), i-Hex, 1-hex-3-en, CO<sub>2</sub>Me, CO<sub>2</sub>Et

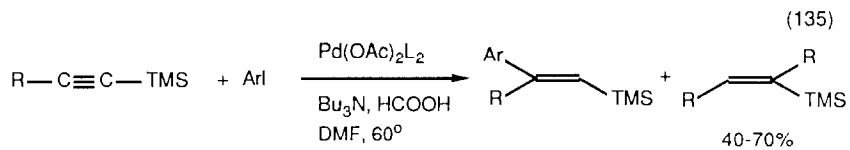

Ar = 4-MeOPh, 4-HOPh, 3-MePh, Ph

R = Me, nC<sub>6</sub>, 4-NH<sub>2</sub>Ph, 4-HOPh, 4-ClPh, 3-MeO<sub>2</sub>CPh, 4-MeO<sub>2</sub>CPh, 3-H<sub>2</sub>NPh  
2-MePh, 4-MeOPh, 4-MeO<sub>2</sub>CPh

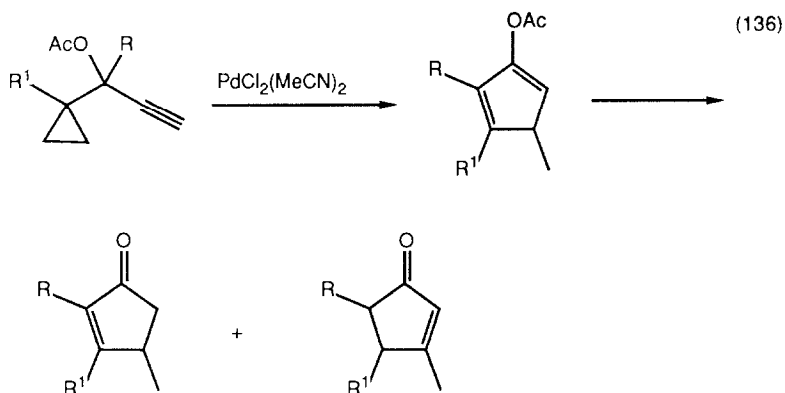

Cationic complexes of alkynes underwent a series of useful reactions (equation 137) [134], (equation 138) [135].

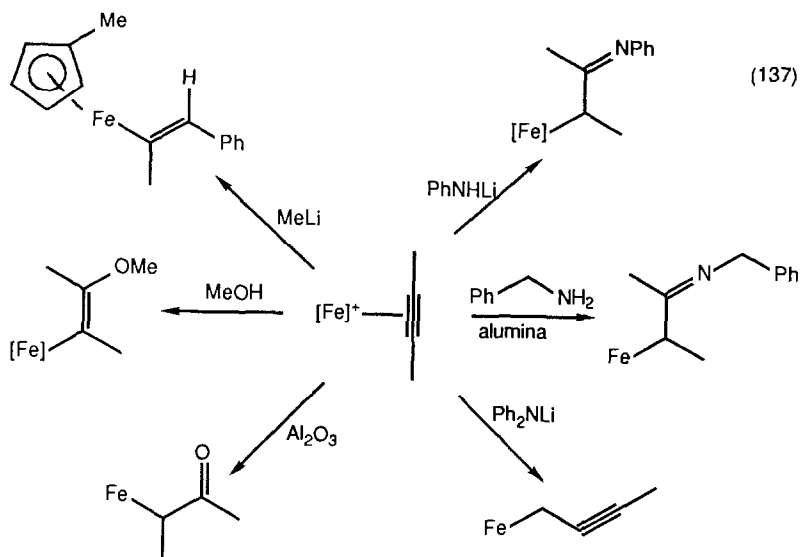

$[Fe] = CpFe(CO)_2$

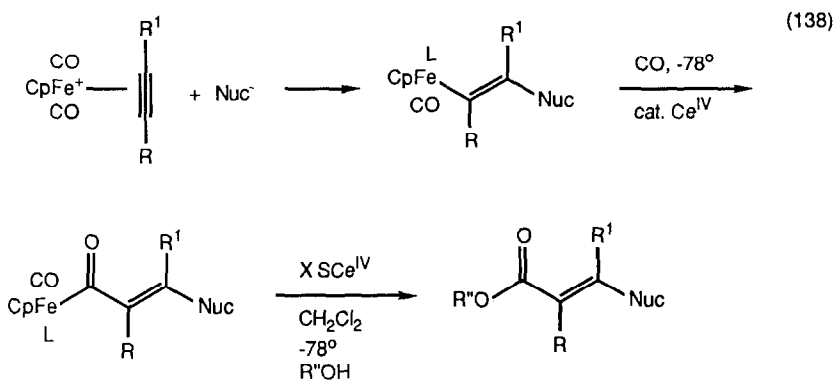

$R = Me, Ph, CO_2Me, Et$

$R^1 = Ph, Me, H$

$Nuc = Me, Ph, 5Ph, CH(CO_2Et)_2$

The reaction of cobalt-stabilized propargyl cations continue to be developed as useful synthetic transformations, particularly when coupled to the Pauson-Khand annulation procedure. Examples are seen in equations 139-141 [136, 137], equation 142 [138, 139] and equations 143-145 [140]. Finally alkynes underwent reaction with phthaloyl cobalt complexes to give naphthoquinones (equation 147) [141].

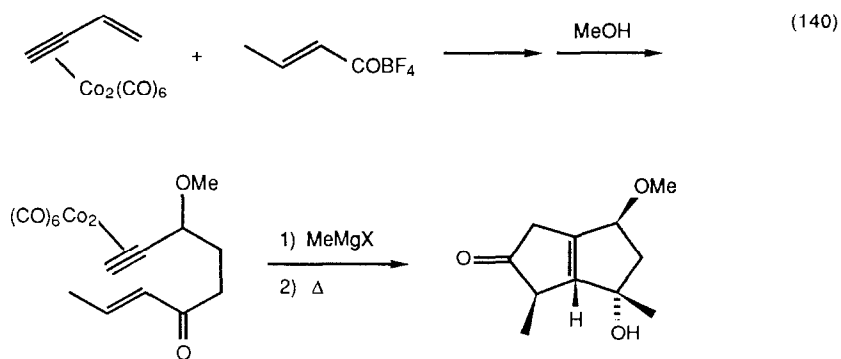
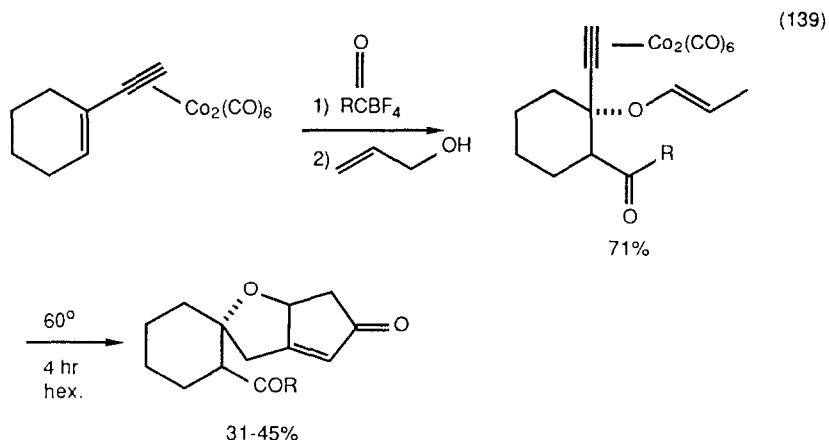

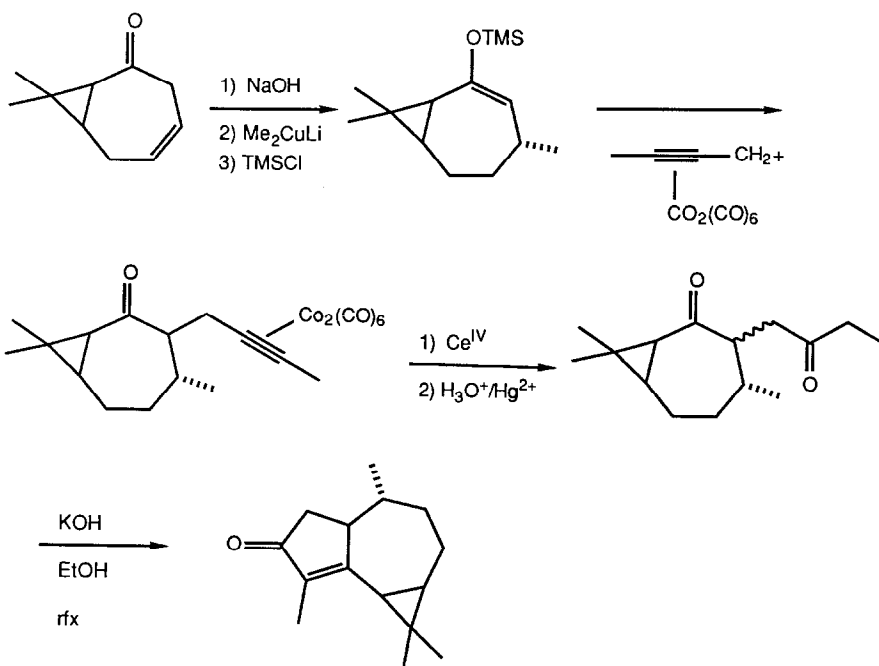
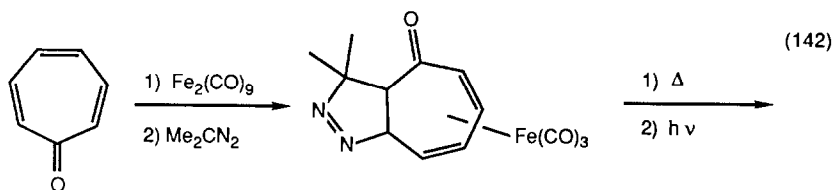
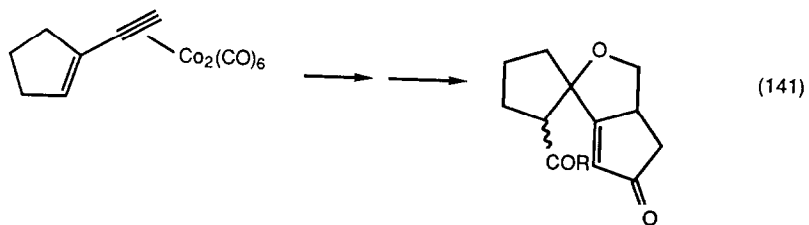

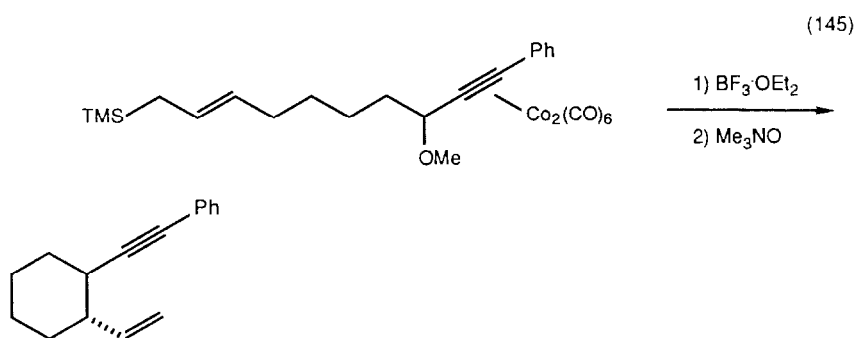
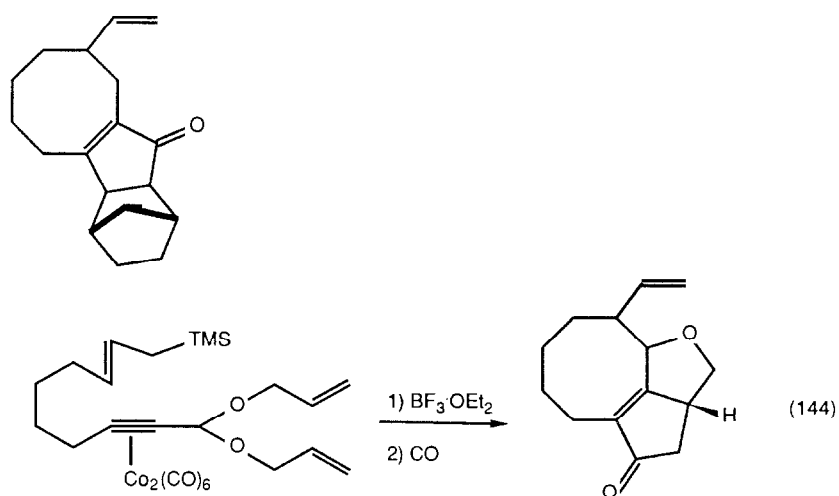
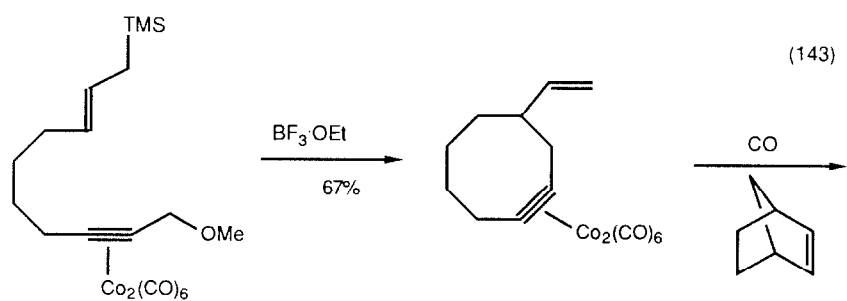

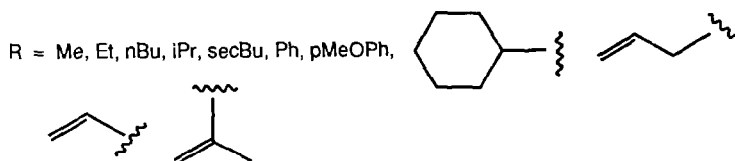
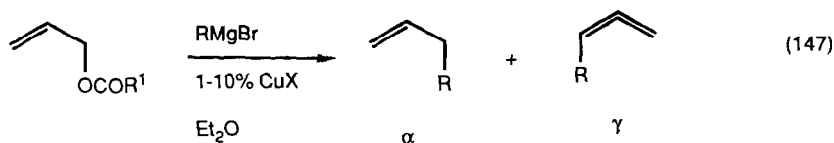
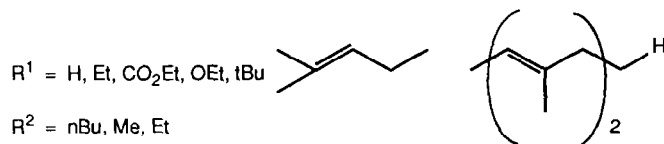
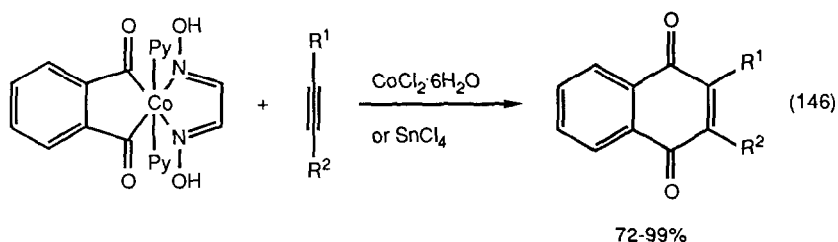

## 7. Alkylation of Allyl, Propargyl, and Allenyl Systems

In a study of copper catalyzed Grignard reactions with allyl esters, catalytic reactions were found to be superior to stoichiometric organocuprate reactions, and copper(I) cyanide favored  $\gamma$ -coupling with alkyl but not aryl or vinyl Grignards (equation 147) [142]. The regio- and stereochemistry of copper catalyzed (equations 148-150) [143] and organocuprate reactions (equation 151) [144] with cyclic allyl esters was studied. Use of chiral nickel catalysts in the reaction of cyclohexenyl ethers with Grignard reagents led to reasonable asymmetric induction (equation 152) [145]. The effects of ligands, reductants, solvents and temperature on the yield, regiochemistry and stereochemistry of the reaction in equation 153 was studied [146]. Palladium complexes catalyzed the coupling of cyclopentadienyl Grignards with allyl ether (equation 154) [147]. The regio- and stereochemistry of the reaction of a number of organometallics with 4-t-butyl cyclohexenyl systems was studied (equation 155) [148].

Copper-catalyzed allylation of propargyl alcohols was used in a synthesis of bicyclic ketones (equation 156) [149]. Chiral propargyl ethers underwent a syn addition of Grignard reagents in the presence of copper(I) catalysts (equation 157) [150].

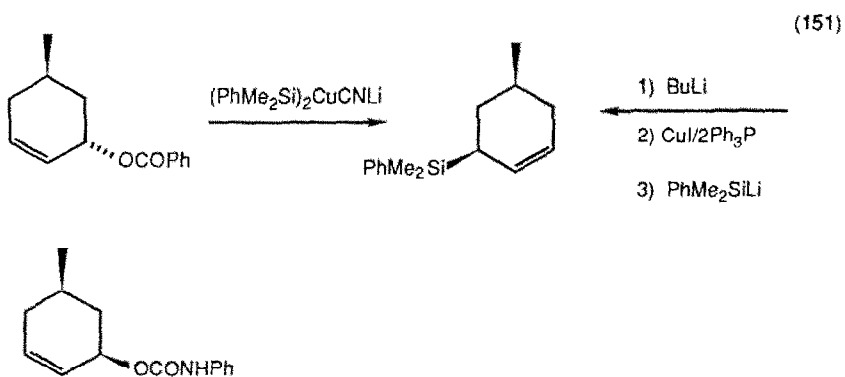
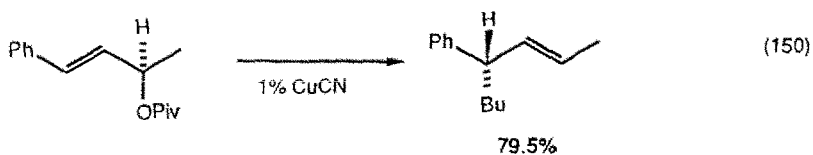
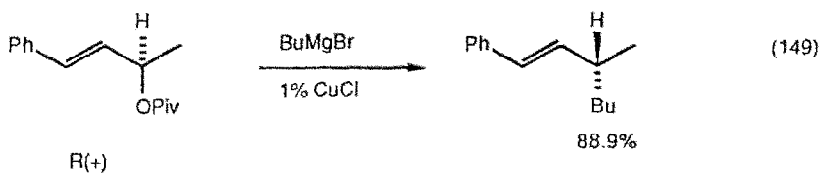
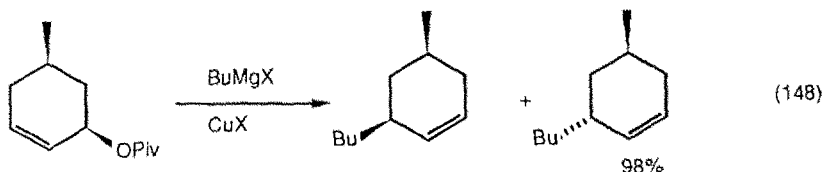



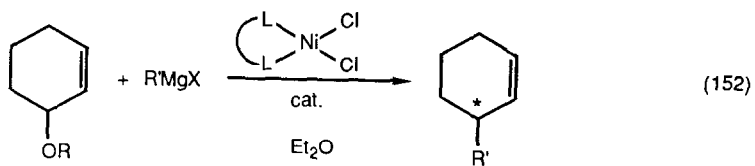

R = H, Ph; R' = Me, Et, Ph,

60-80% yield/up to 50% optical purity

= chiral prophos, chiraphos, phenphos cyphos

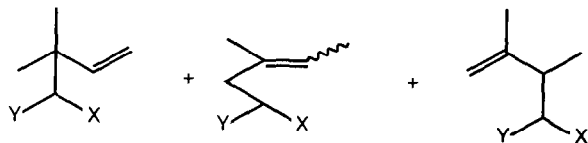
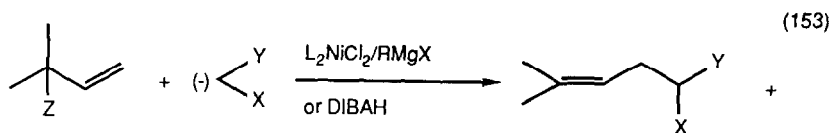

Z = SO<sub>2</sub>Ph, SO<sub>2</sub>tol

X = CO<sub>2</sub>R, SO<sub>2</sub>Ph

Y = CO<sub>2</sub>R, CN, SO<sub>2</sub>Ph

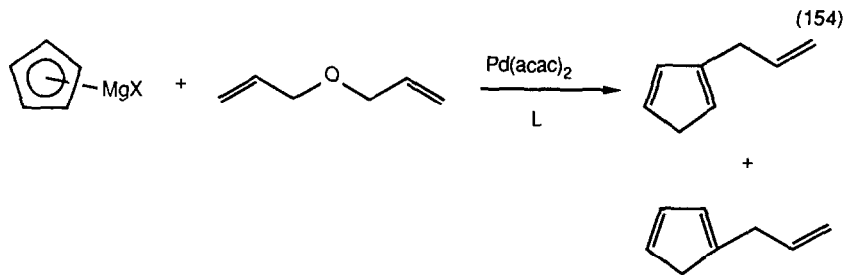

15:85 96% yield

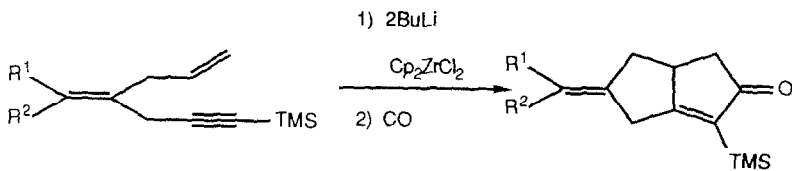
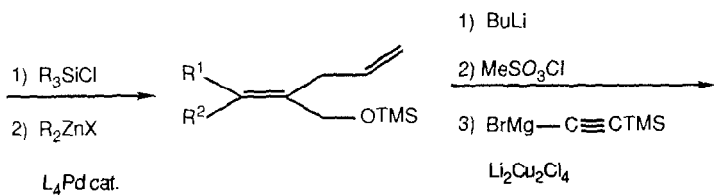
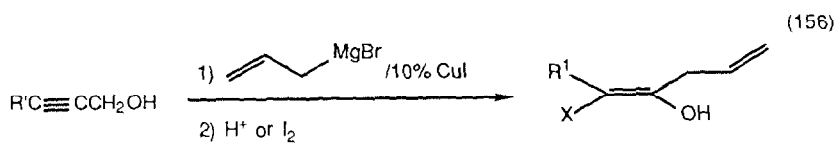
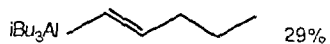
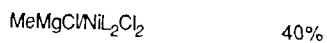
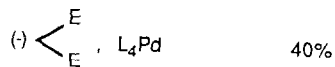

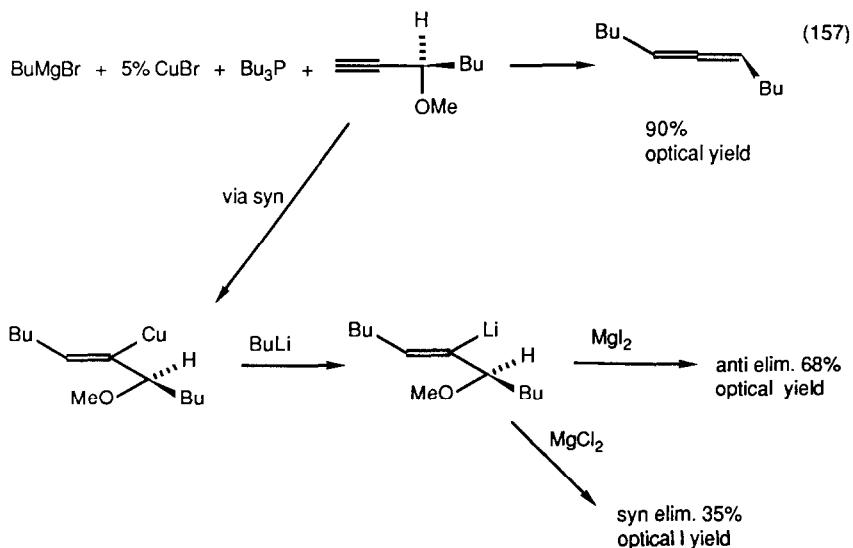

Molybdenum(0) catalyzed reactions of allylic acetates and palladium(II) catalyzed cyclization of 1,6-enynes was the topic of a dissertation [151]. Palladium(0) catalyzed the alkylation of allylic acetates by stabilized carbanions (equation 158) [152], (equation 159) [153], (equation 160) [154]. The anion of imines of glycine esters alkylated allylic acetates in the presence of palladium(0) catalysts (equation 161) [155]. With chiral ligands asymmetric induction was observed (equation 162) [156]. Palladium(0) complexes also catalyzed the alkylation of allyl acetates by Reformatsky reagents (equation 163) [157], and by carbanions cathodically generated [158]. This chemistry was used to synthesize long chain unsaturated acids (equation 164) [159], substituted enol acetates (equation 165) [160] and unsaturated ketones from  $\beta$ -ketoacids with extension of  $\text{CO}_2$  (equation 166) [161].

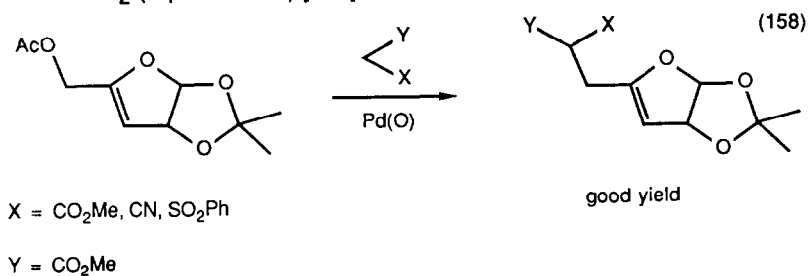

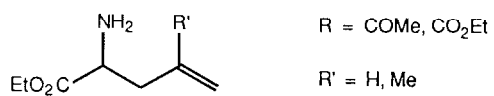
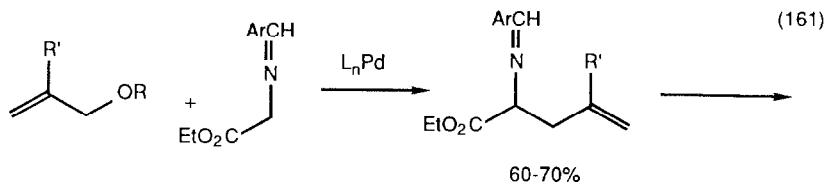
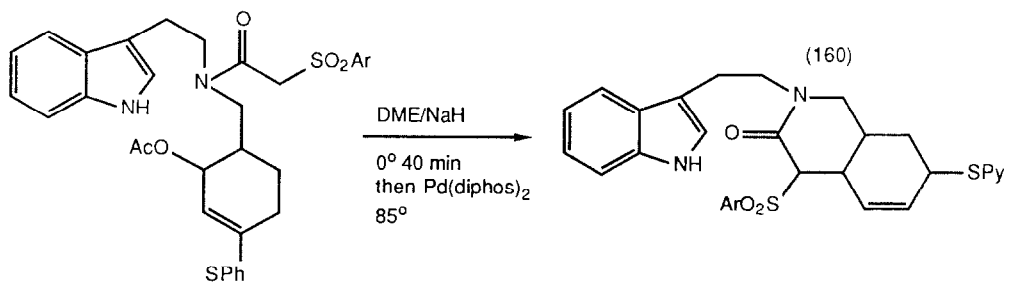
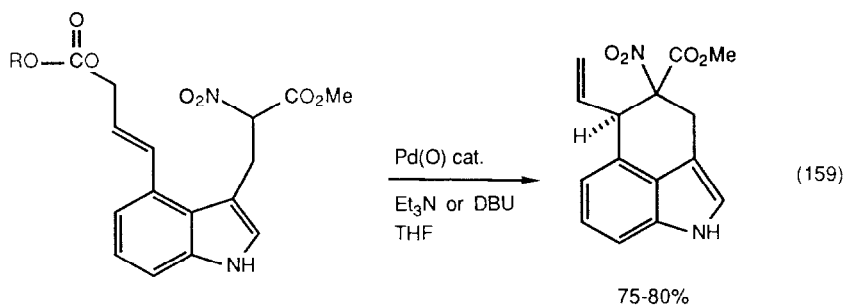

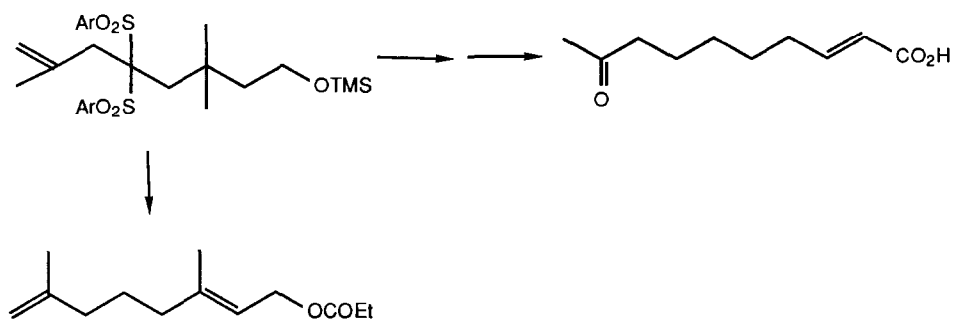
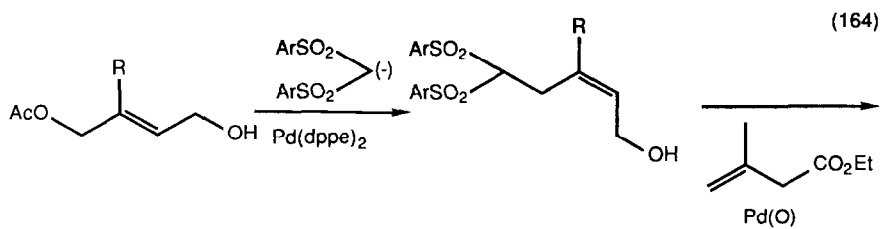
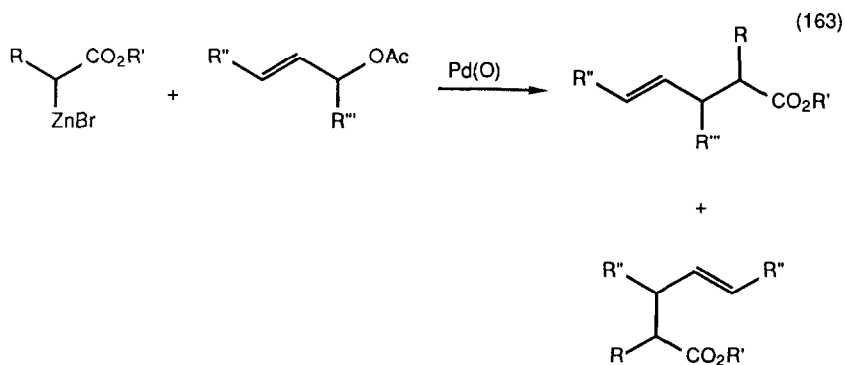
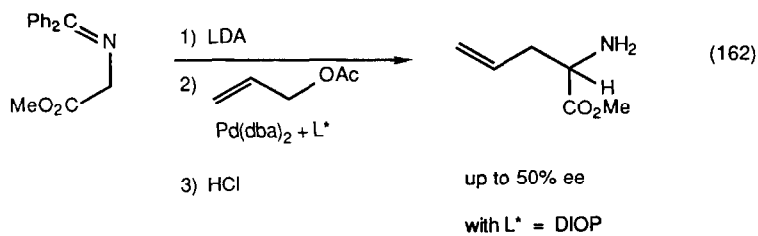

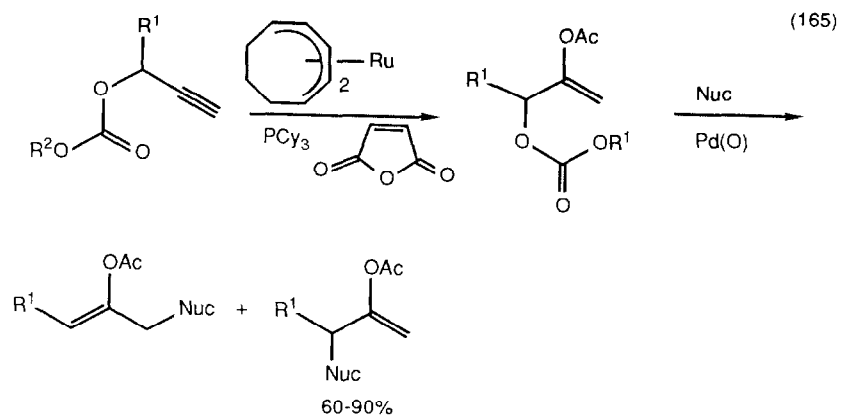

$\text{R}^1 = \text{H, Me, nC}_6$ ;  $\text{R}^2 = \text{cat. Me}$

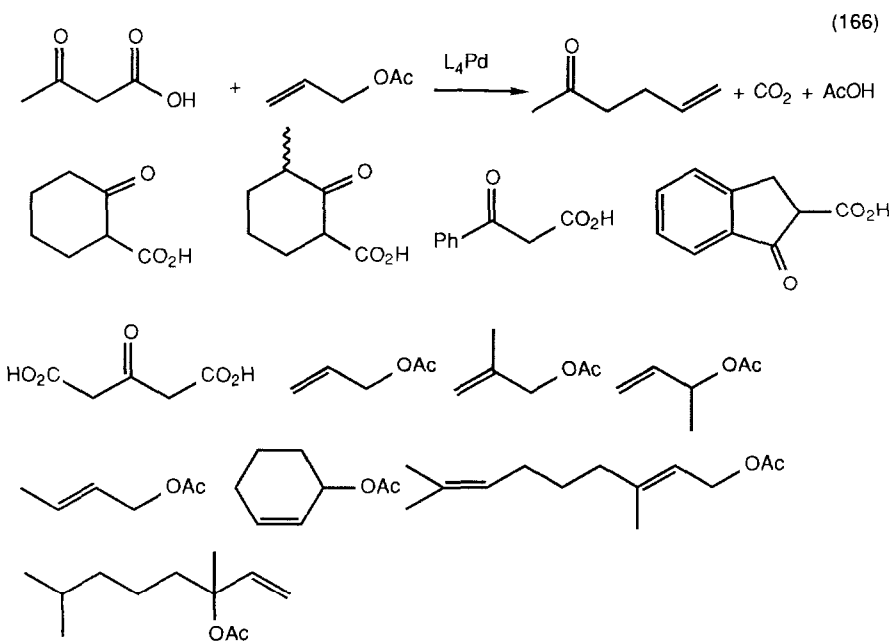
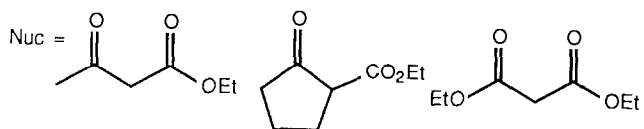

Asymmetric induction in the palladium(0) catalyzed reactions of allyl acetates with carbanions has been extensively studied. Racemic allyl acetates were allowed to react with 0.5 equivalents of malonate anion in the presence of 1% of a chiral palladium catalyst. At 50% conversion, the recovered acetate had 56% ee. At higher (80%) conversion the acetate had >95% ee, in a kinetic resolution process (equation 167) [162]. The procedure was shown to proceed with net retention for both regioisomers (equation 168) [163]. A variety of chiral ferrocenyl ligands led to high ee's in this allylic alkylation (equation 169) [164]. One problem was that chiral acetates underwent some racemization during this process (equation 170) [165]. Enamines of chiral proline esters alkylated allyl acetates with up to 100% ee (equation 171) [166]. Enamines also alkylated ketene acetals under palladium(0) catalysis (equation 172) [167].

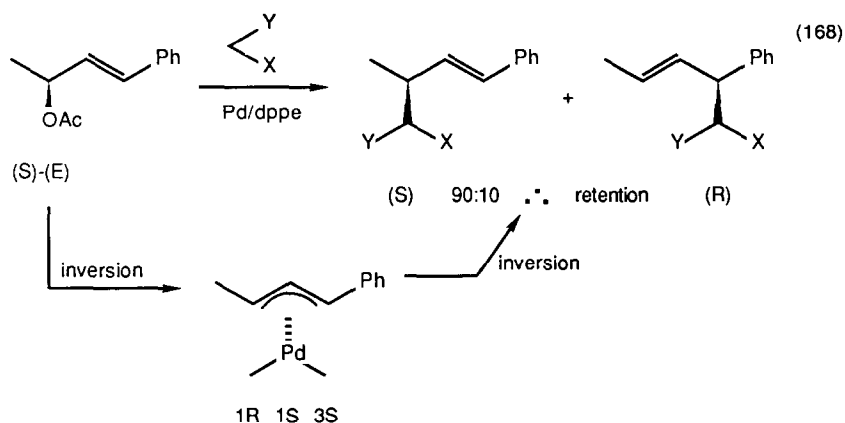
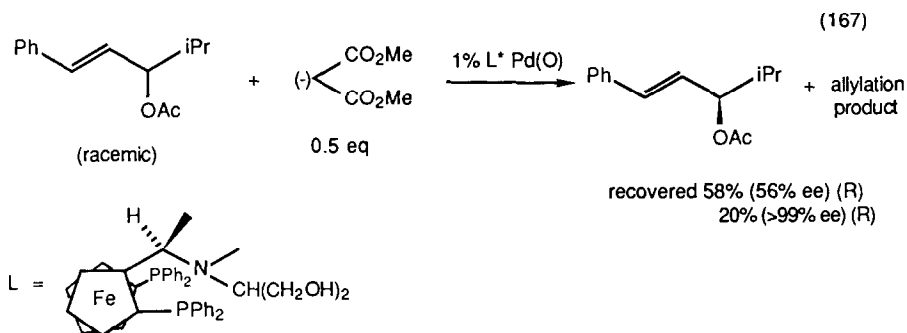

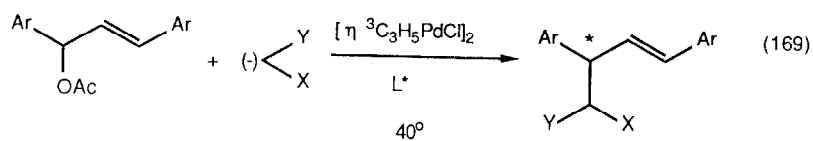

X = COMe, CO<sub>2</sub>Me

70-90% yield

Y = COMe, C<sub>6</sub>H<sub>5</sub>, CO<sub>2</sub>Me

up to 92% ee

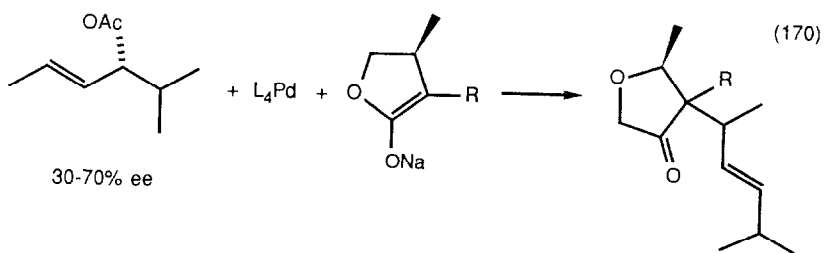
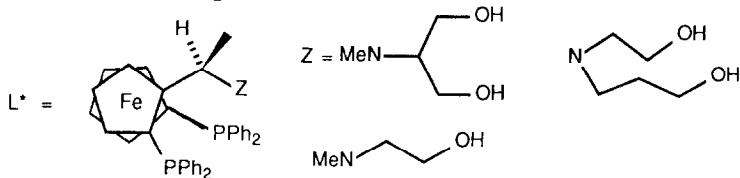

30-70% ee

high yield  
OAc suffers 11% racemization  
P(O)(OEt)<sub>2</sub> 4-6% racemization

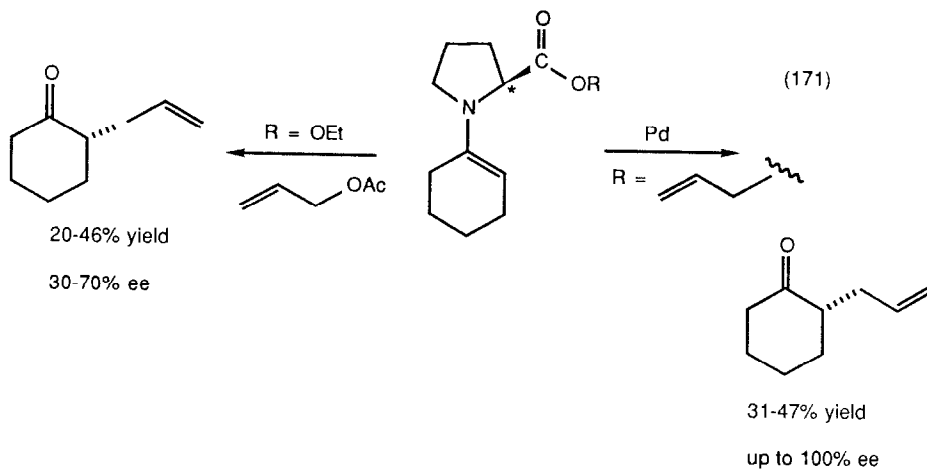

20-46% yield

30-70% ee

31-47% yield

up to 100% ee



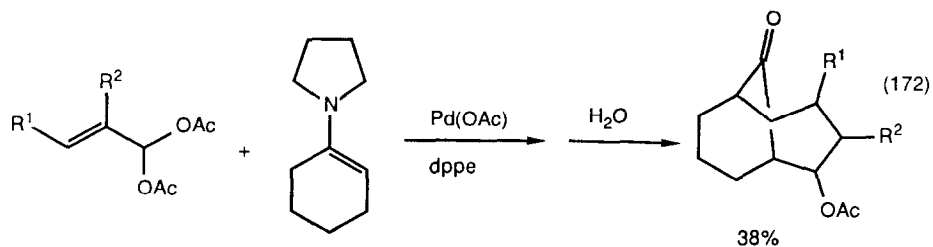

The full experimental details of the alkylation of allyl nitro compounds using palladium catalysis have appeared (equation 173) [168], (equation 174) [169].  $\alpha$ -Nitroketones proved effective anions for palladium catalyzed allylic alkylation (equation 175) [170]. Ketone enolates alkylated DCC adducts of allylic alcohols in the presence of Pd(0) catalysts (equation 176) [171]. Allyl acetates of vinylsulfones were alkylated with  $S_N2'$  regiochemistry by organo cyanocuprates (equation 177) [172].

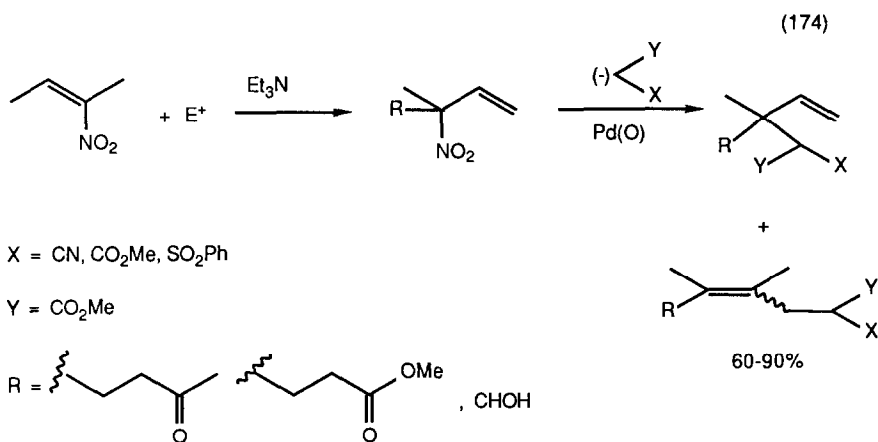
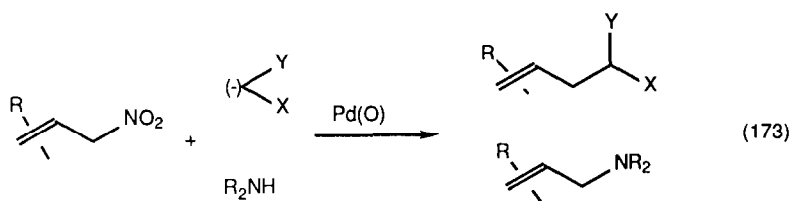

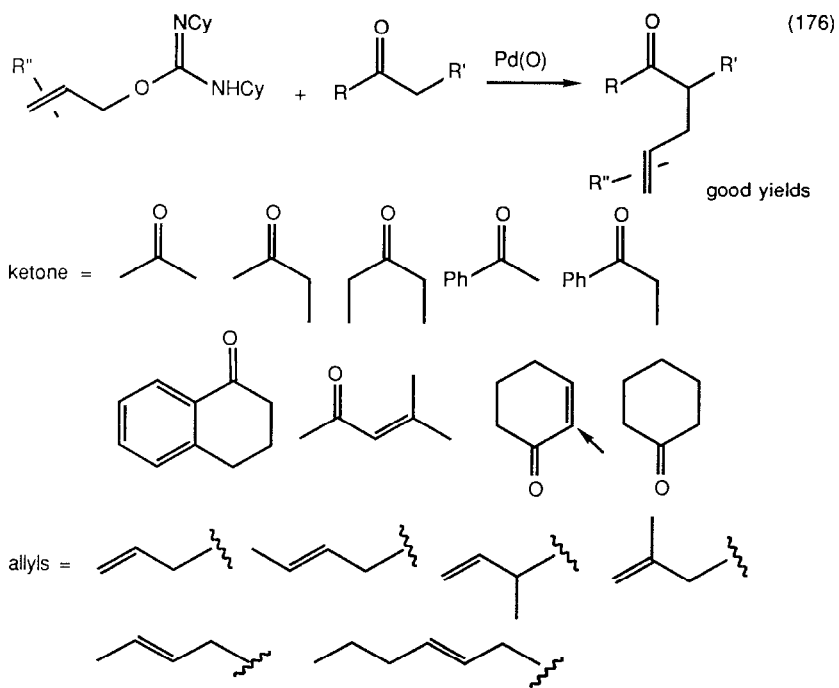
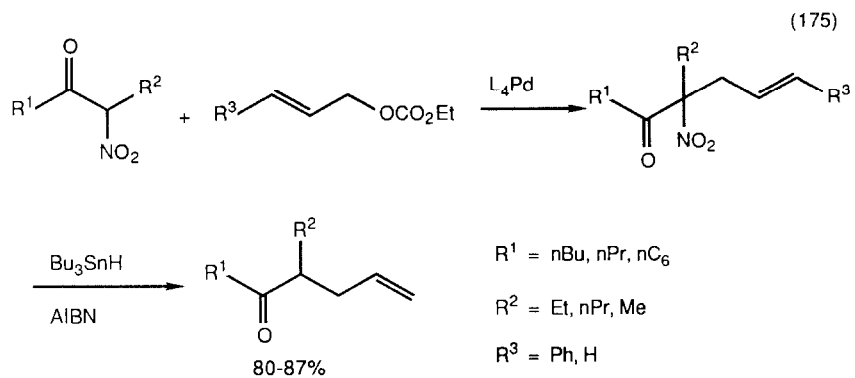

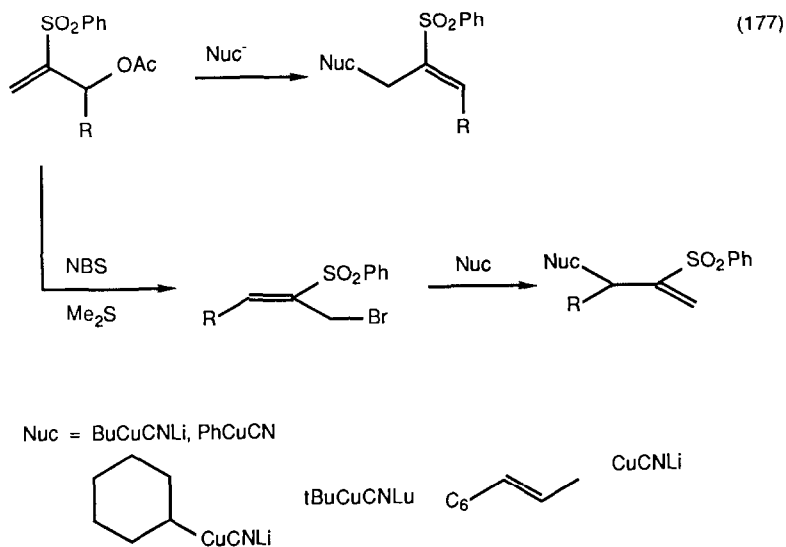

Palladium catalyzed the reaction between acetates and cyclopentadienide and indenyl lithium anions (equation 178) [173]. Triallylarsenites could serve as allyl sources in palladium(0) catalyzed reactions with stabilized carbanion (equation 179) [174]. Palladium(0) catalyzed the reaction between allyl acetates and aryl bromides in the presence of hexamethyl ditin (equation 180) [175].

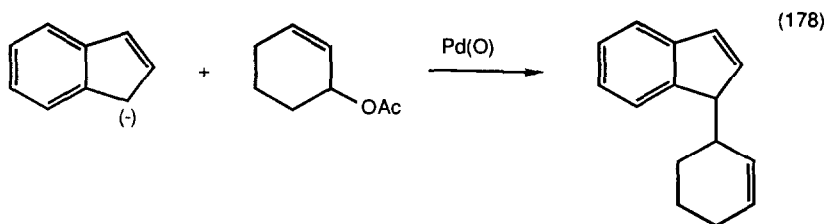

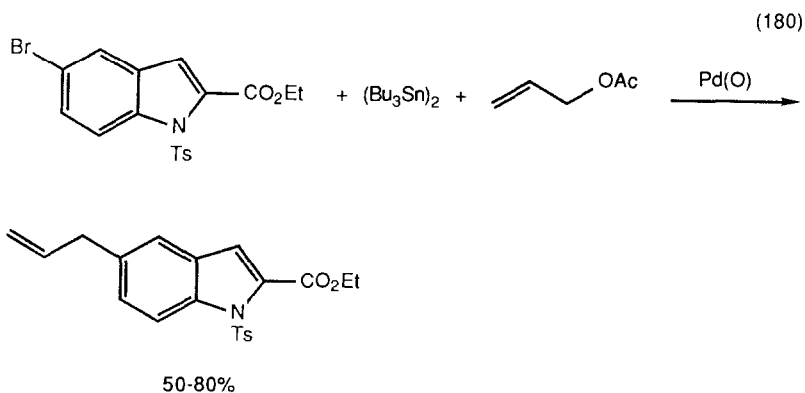
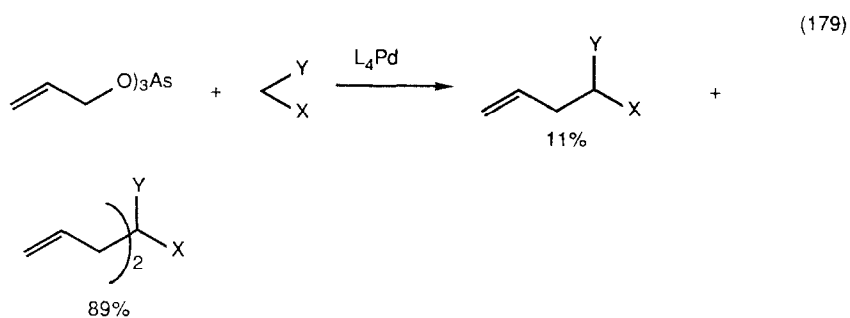

Allyl epoxides also underwent a palladium(0) catalyzed alkylation by stabilized carbanions. With additional unsaturation migration of the  $\eta^3$ -allylpalladium system was observed (equation 181) [176]. Palladium(II) salts catalyzed the alkylation of allyl epoxides by organomercurates (equation 182) [177]. With  $\beta$ -keto acids, decarboxylation accompanied alkylation (equation 183) [178]. Intramolecular versions were used to form large (equation 184) [179] and smaller (equation 185) [180] rings.

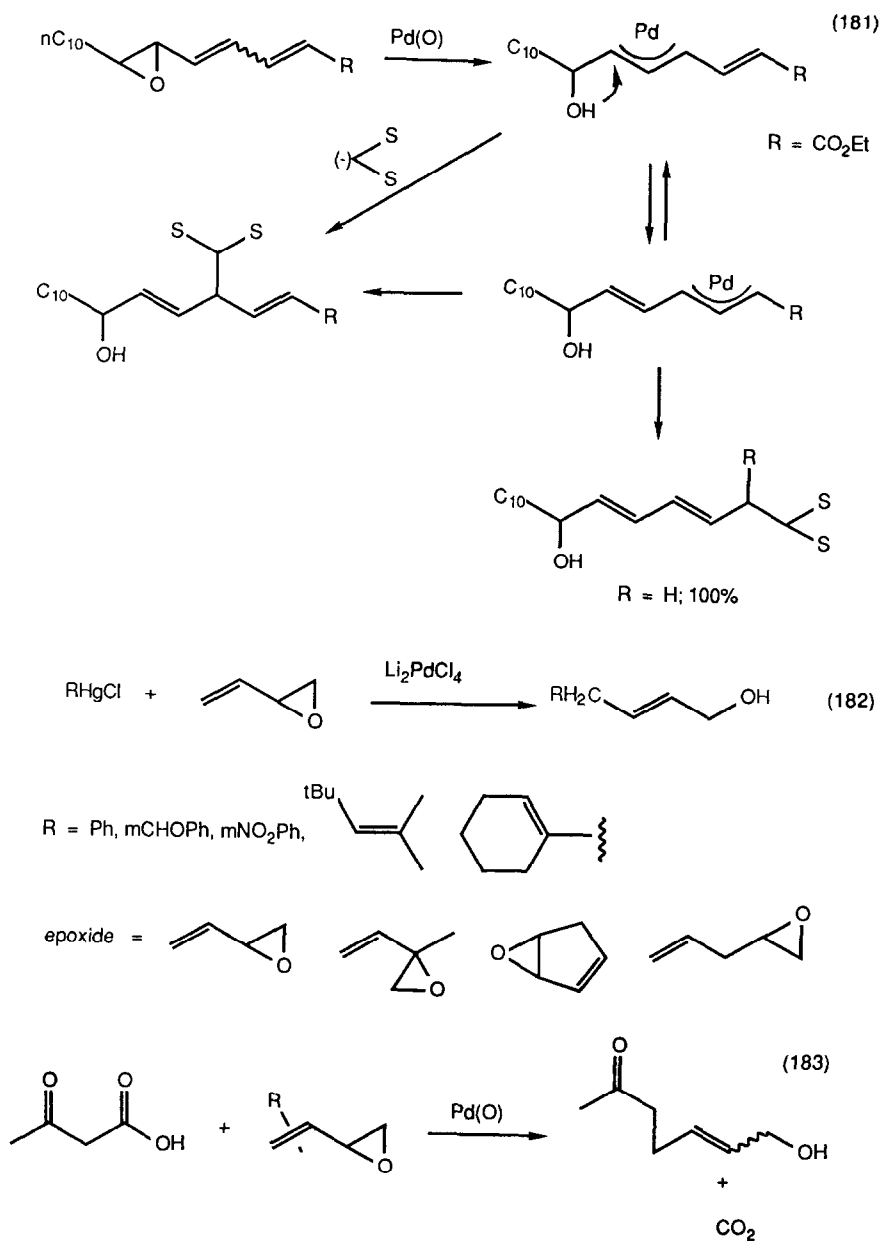

(equation 183 continued)

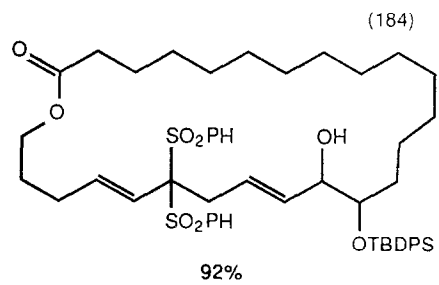
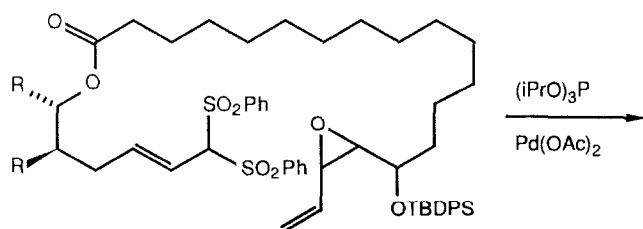
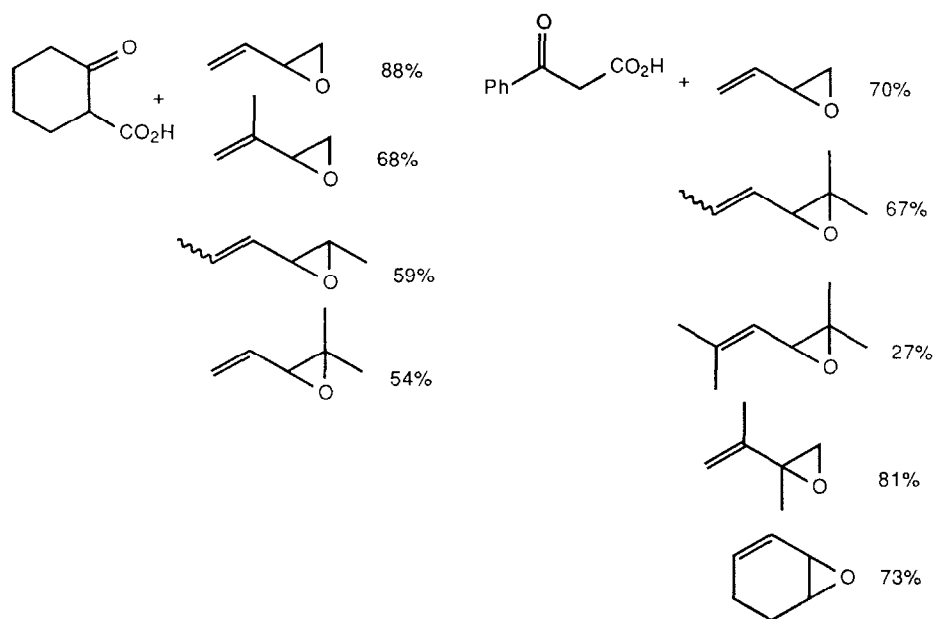

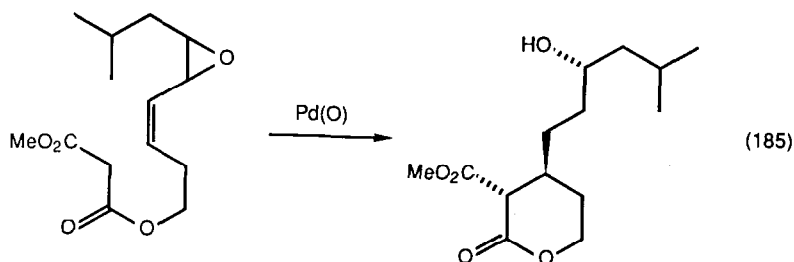

Palladium(0) complexes also catalyzed the reaction of allyl acetates with ketenes (equation 186) [181] and vinyl cyclopropanes (equation 187) [182]. Palladium(II) salts catalyzed the arylation of allyl alcohols by iodobenzene (equation 188) [183].

Propargyl acetates were reduced to allenes by samarium(II) iodide in the presence of palladium(0) catalysts (equation 189) [184], and were alkylated to allenes by vinylzinc reagents (equations 190 and 191) [185].

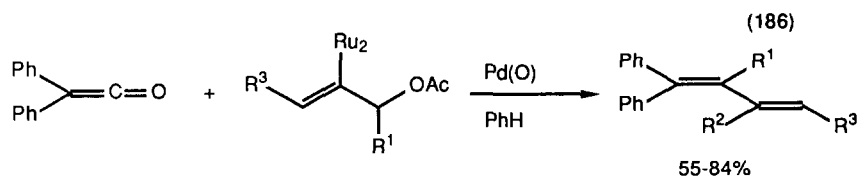

$R^1 = \text{H, Me}$

$R^2 = \text{H, Me}$

$R^3 = \text{H, Me, nPr, Ph}$

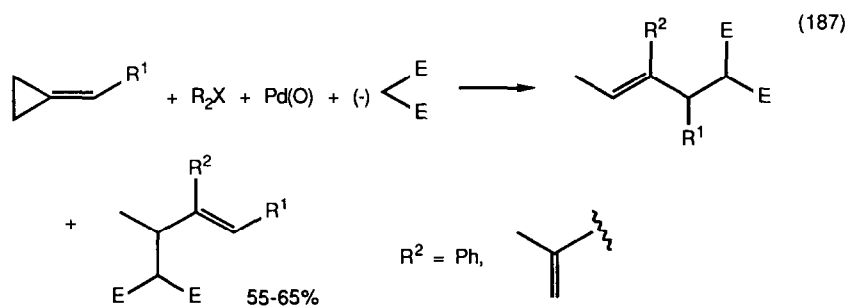

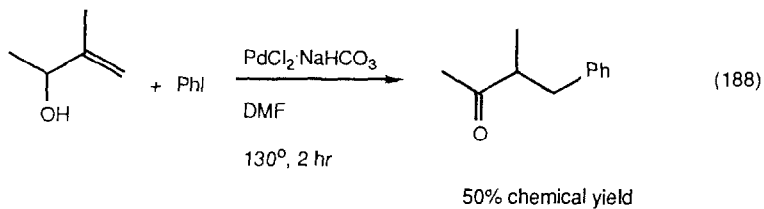

S(+)  $\longrightarrow$  S(+) 22.5% optical yield

R(-)  $\longrightarrow$  R(-) 27.5% optical yield

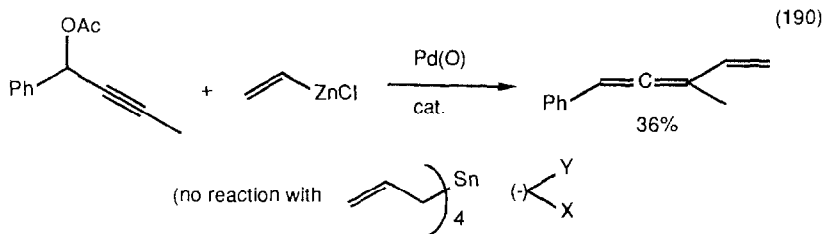
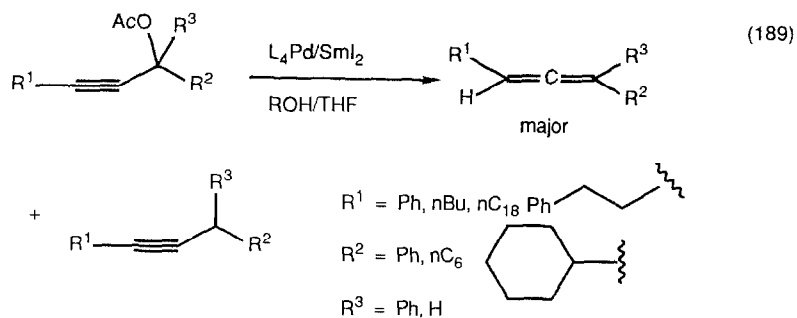



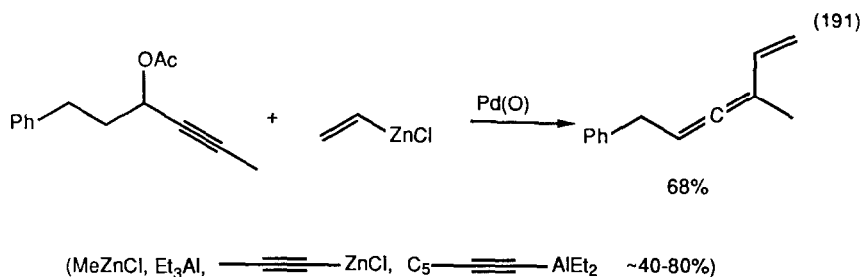

## 8. Coupling Reactions

Coupling processes of organic halides electrocatalyzed by nickel complexes has been reviewed (32 references) [186]. Aryl halides and vinyl halides were electrochemically coupled in the presence of nickel catalysts (equation 192) [187]. Bromopyridines and bromoquinolines were coupled by nickel complex reducing agents (equation 193) [188]. Aryl triflates were coupled to biaryls in the presence of nickel(II) salts and zinc under ultrasonic irradiations (equation 194) [189], and under more normal conditions (equation 195) [190]. Vinyl halides were also coupled by nickel "complex reducing agents" (equation 196) [191]. Allylic halides and acetates were reductively coupled exclusively head to tail by electrochemical methods in the presence of PdCl<sub>2</sub> and R<sub>3</sub>SnCl (equation 197) [192]. Gem dihalides were dimerized to diynes by palladium complexes under carbon monoxide (equation 198) [193].

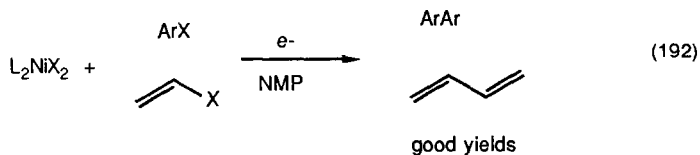

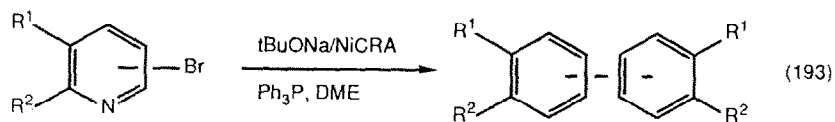

60-90%

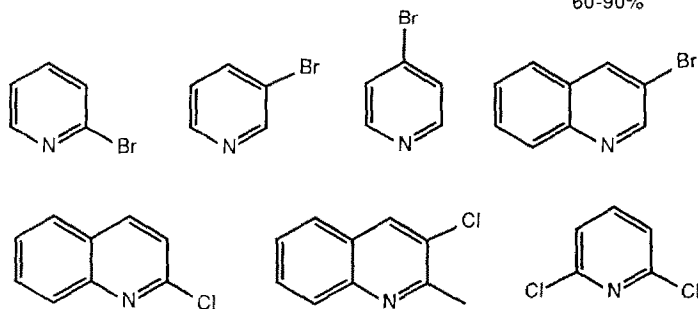
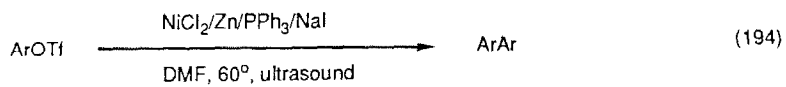
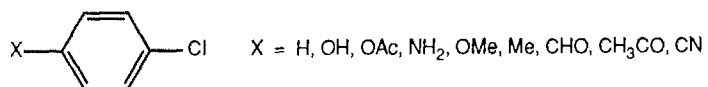
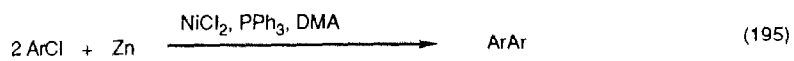
NiCRA = NaH/tBuONa/Ni(OAc)<sub>2</sub>Ar = pMePh, mMePh, oMePh, pMeOPh, 1-Naphth, oMeO<sub>2</sub>CPh

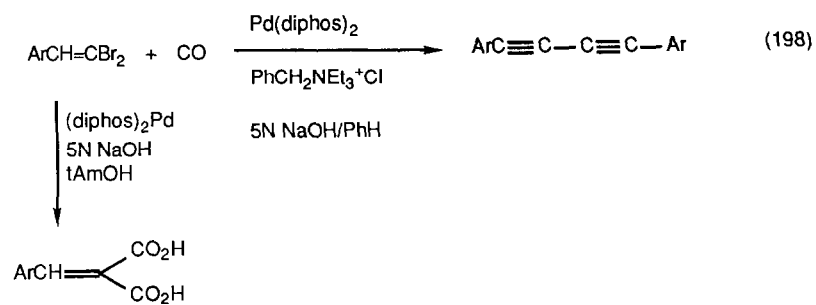
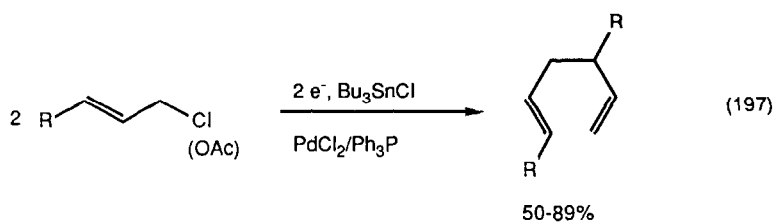
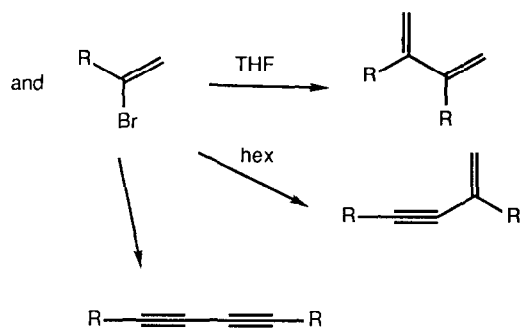
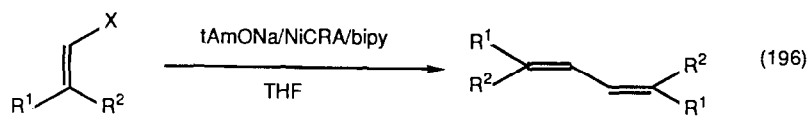

Thiophenes and furans were oxidatively coupled by ruthenium(III) salts (equation 199) [194]. Ruthenium dioxide effected oxidative aryl couplings (equation 200) [195, 196].

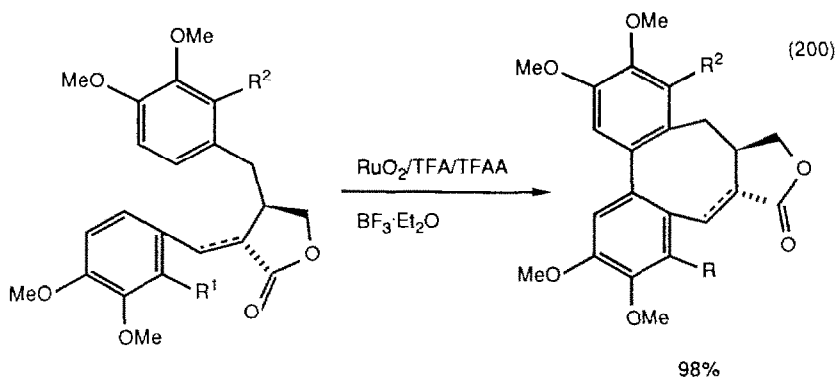
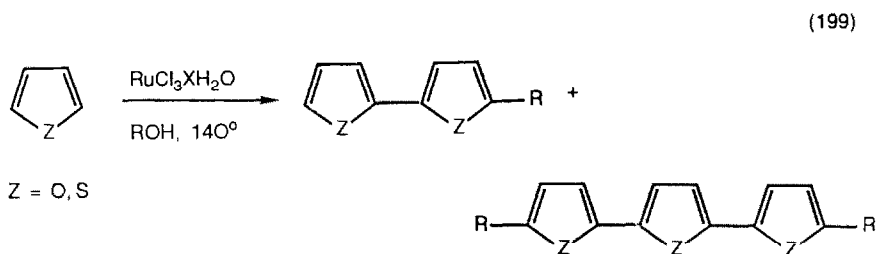

Aryl Grignards were coupled to  $\alpha,\omega$ -dibromoalkanes in the presence of copper(I) iodide (equation 201) [197]. Vinyl cuprates were oxidatively coupled to dienes by copper(II) chloride (equation 202) [198]. Dienes were synthesized by the nickel catalyzed coupling of vinyl bromides with vinyl halides (equation 203) [199].

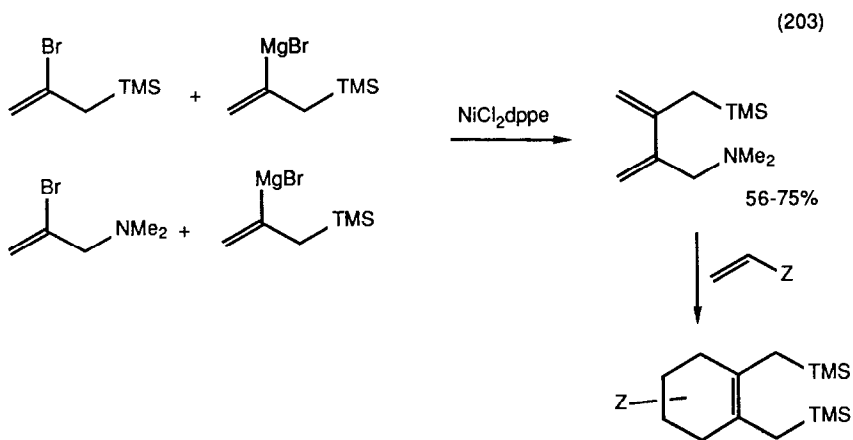
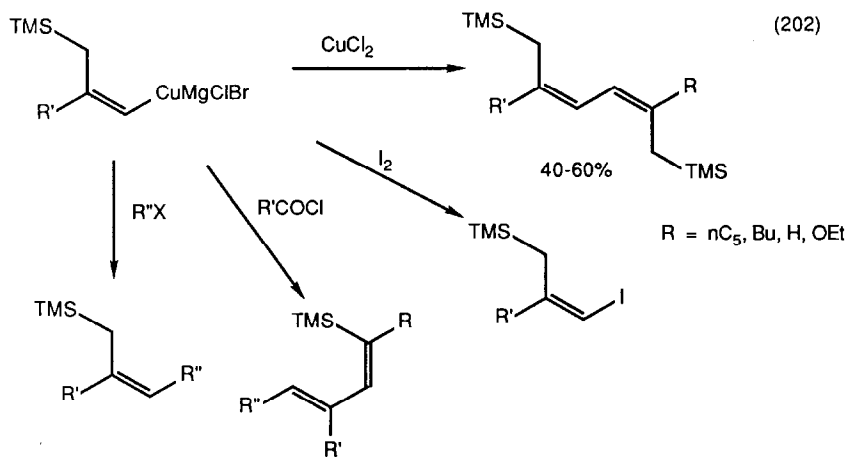
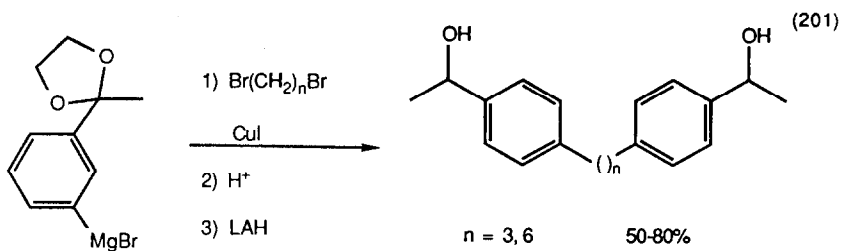

Methyl acrylate was dimerized by ruthenium(III)/zinc (equation 204) [200]. Norbornene was coupled by nickel(II) salts/sodium borohydride (equation 205) [201].  $\sigma$ -Nickel complexes of norbornadiene were oxidatively coupled (equation 206) [202]. Isocyanates were reductively coupled by ruthenium clusters (equation 207) [203].

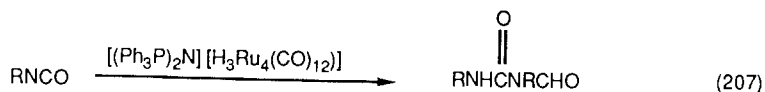
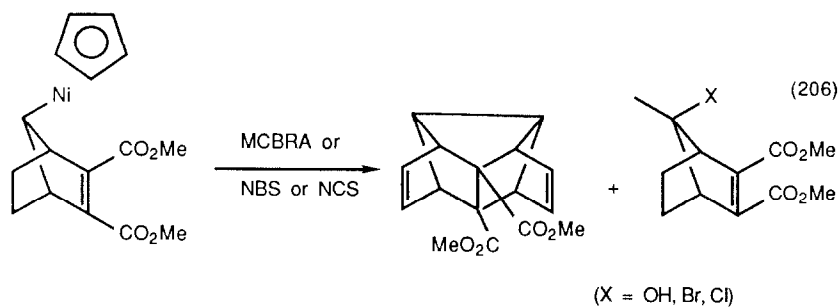
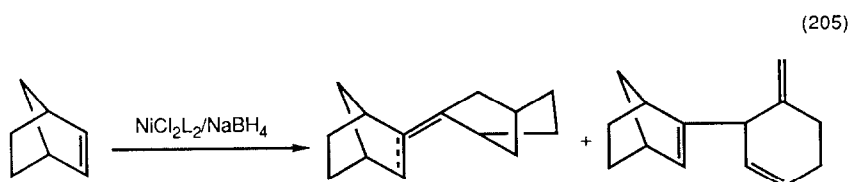
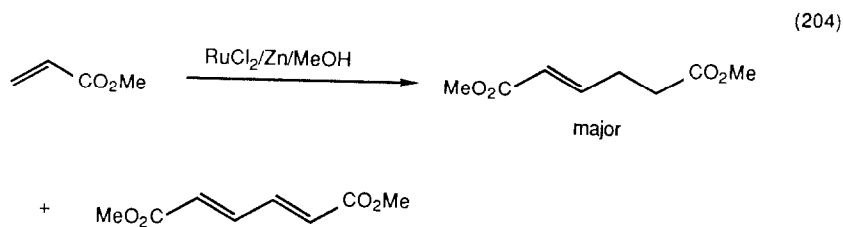

R = Me, Et, Pr

1,6-Dienes were photochemically dimerized in the presence of copper(I) triflate (equation 208) [204]. Nickel(0) complexes dimerized tetraenes (equation 209) [205]. Zirconocenes reductively cyclized ene ynes (equation 210) [206].

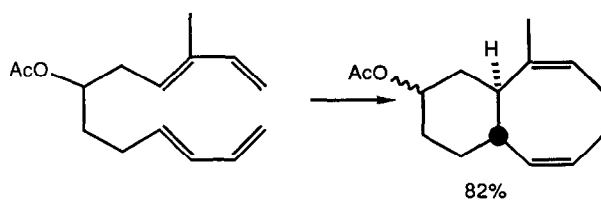
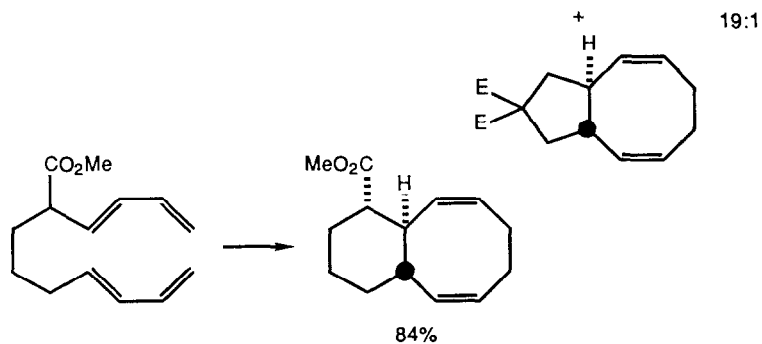
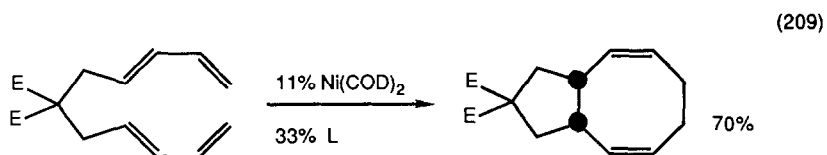
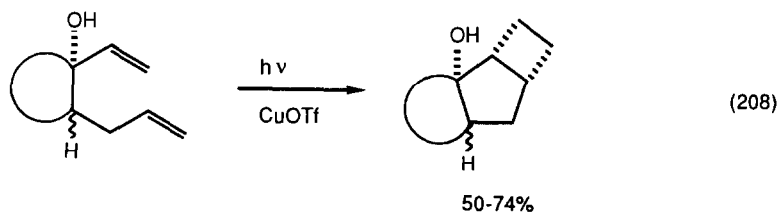

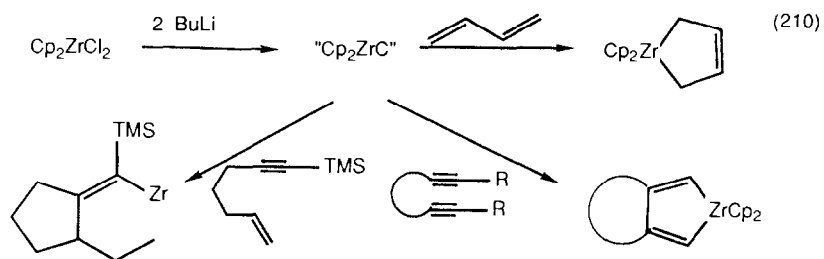

Reduced titanium reductively coupled conjugated enones (equation 211) [207] and aldehydes (equation 212) [208], (equation 213) [209]. Molybdenum hexacarbonyl coupled thioketals, (equation 214) [210]. Titanium(III) salts coupled  $\alpha$ -keto esters to ketones (equation 215) [211].

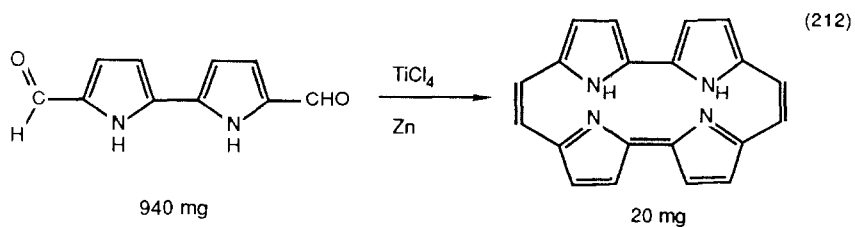
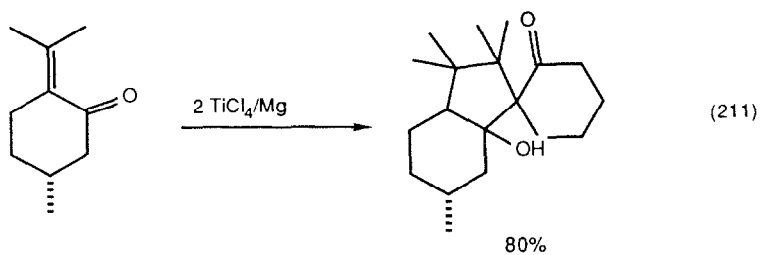



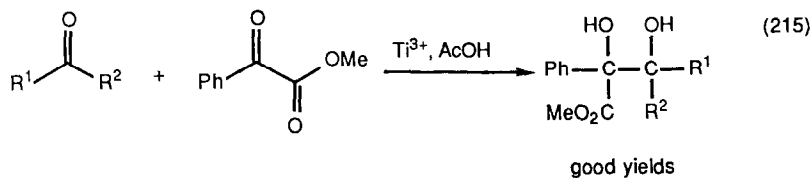
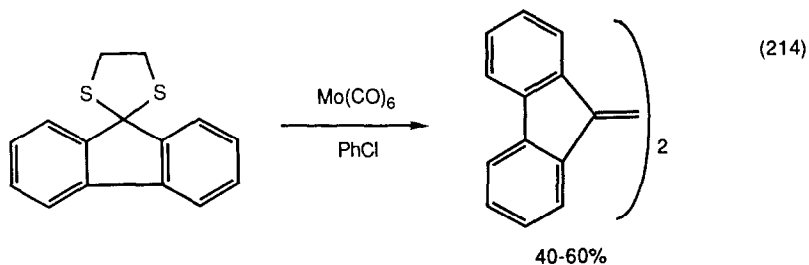
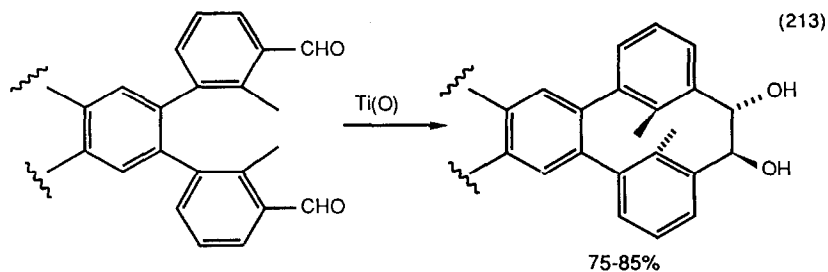

$R^1 = \text{Me, Et, (CH}_2\text{)}_4, \text{(CH}_2\text{)}_5, \text{(CH}_2\text{)}_6$

$R^2 = \text{Me, Et, nPr, nBu, iPr, tBu, cyclo-C}_6$

### 9. Alkylation of $\pi$ -Allyl Complexes

New general synthetic methods involving  $\pi$ -allylpalladium complexes as intermediates and neutral reaction conditions have been reviewed [120 references] [212], as has carbon-carbon bond formation using  $\eta^3$ -allyl complexes [12 references] [213], and asymmetric coupling reactions involving allylic compounds [43 references] [214]. Ligand induced coupling from di(allylic) complexes of palladium was the topic of a dissertation [215]. As were studies of reactions of iron and tungsten-cycloalkyl and

platinum  $\eta^1$ -allyl complexes with electrophiles [216]. The full details of the reactions of palladium(0) complexes with allyl acetates, ethers, sulfides, selenides, alcohols and amines have been published [217].

The mechanism of formation of  $\eta^3$ -allylpalladium complexes from the reaction of olefins with palladium(II) salts has been studied using deuterium isotope effects. The most likely path was found to involve proton abstraction by a base, not insertion of palladium into a C-H bond (equation 216) [218]. The reaction of s-trans-conjugated dienes with  $\text{Na}_2\text{PdCl}_4$  to give  $\pi$ -allylpalladium complexes has been studied (equation 217) [219]. Alkylated cycloheptyl systems were made by chloropalladation/nucleophilic attack on cycloheptadiene systems (equation 218) [220]. Norbornene inserted into  $\pi$ -allylpalladium complexes to produce  $\sigma$ -alkylpalladium complexes, which were further elaborated (equation 219) [221].

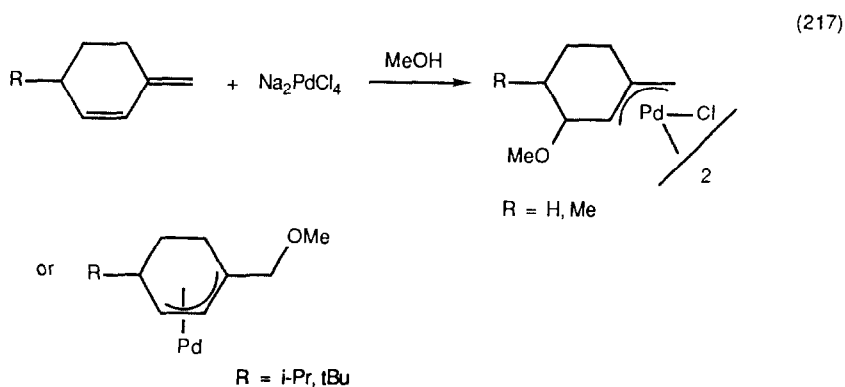
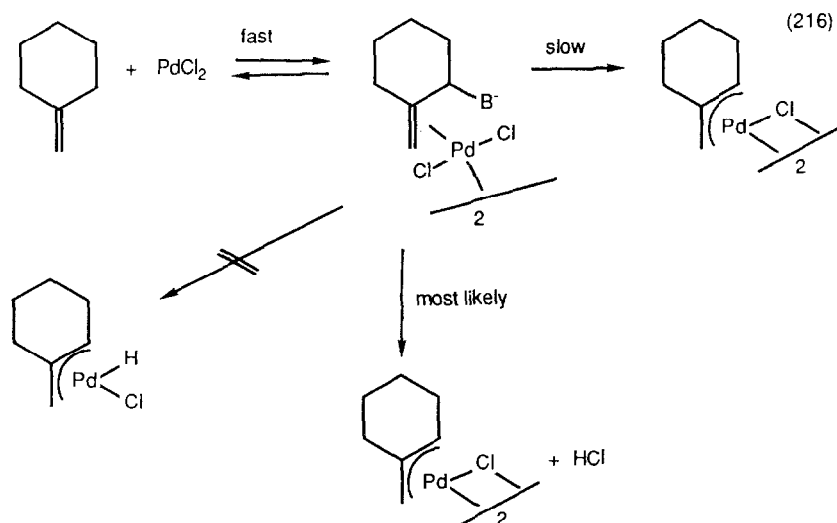

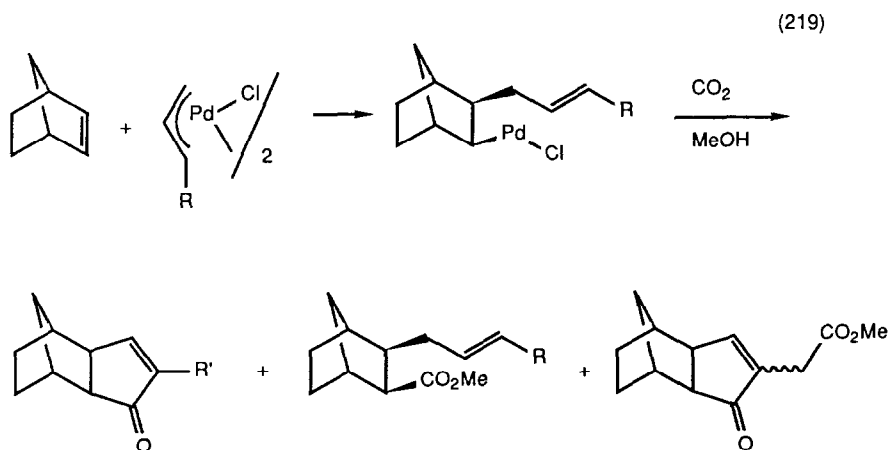
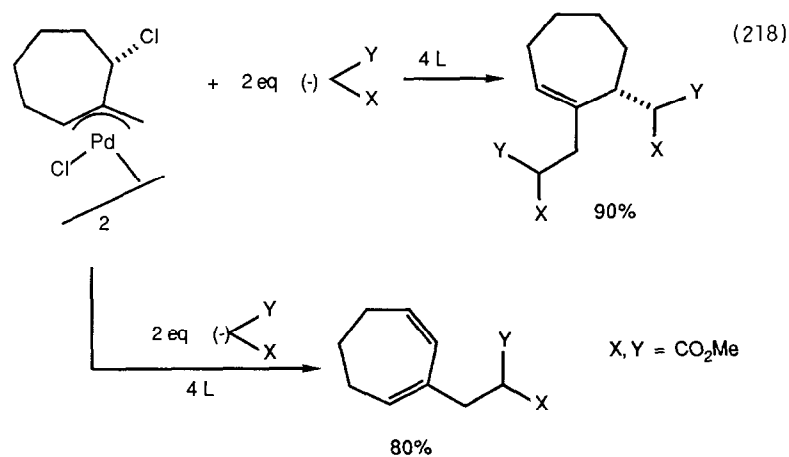

$\eta^1$ -Allylpalladium complexes underwent reaction with electrophiles to give allyl substitution products (equation 220) [222, 223] while  $\eta^3$ -allylpalladium complexes cleaved only the aryl group (equation 221) [223].

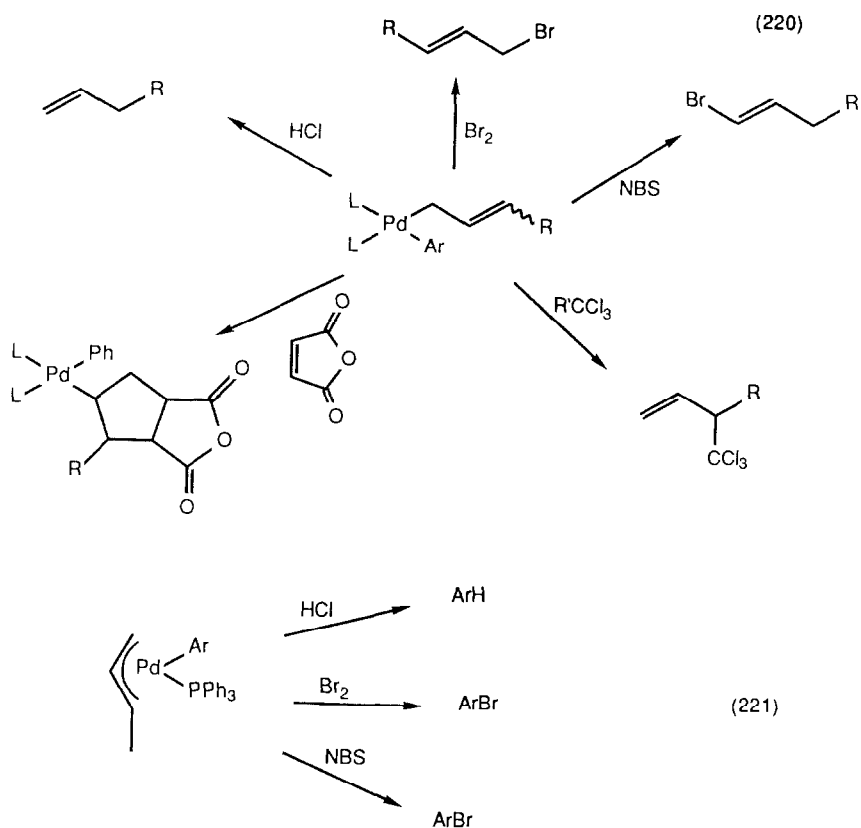

Diene-cobalt tricarbonyl complexes were 1,4-dialkylated via their  $\eta^3$ -allylcobalt complex intermediates (equation 222) [224]. Cationic  $\eta^3$ -allyl iron complexes were generally reactive toward nucleophiles (equations 223-225) [225]. 2-Trimethylsilylmethylallyl nickel complexes transferred this allyl group to a number of organic halides (equation 226) [226].

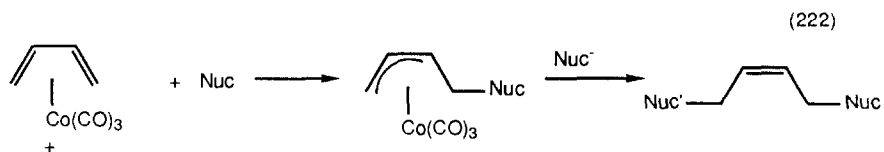

Nuc = Py, NaBH<sub>3</sub>CN, PhMgBr, Me<sub>3</sub>P, Ph<sub>3</sub>P, (MeO)<sub>3</sub>P, NaCH(CO<sub>2</sub>Me)<sub>2</sub>, MeOH

Nuc' = NaCH(CO<sub>2</sub>Me)<sub>2</sub>      Nuc = H      33%

Nuc, Nuc' = NaCH(CO<sub>2</sub>Me)<sub>2</sub>      35%

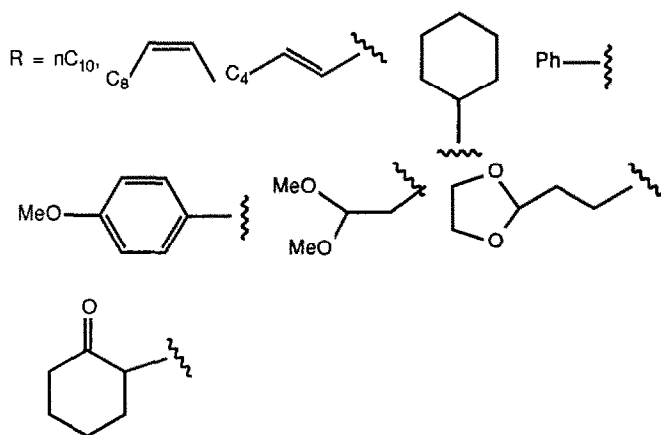
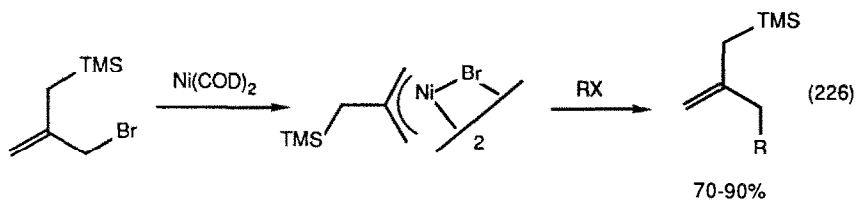
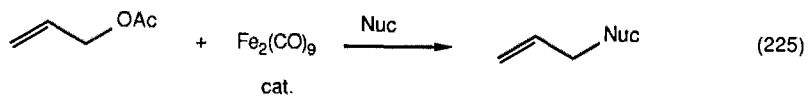
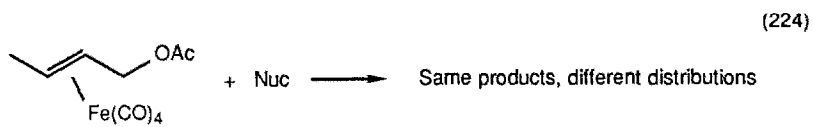
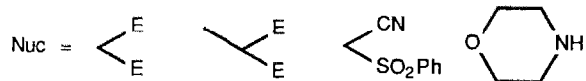
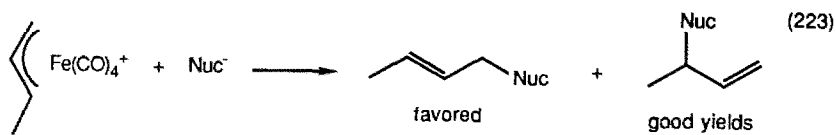

References p. 372

## 10. Alkylation of Carbonyl Compounds

Titanium(IV) chloride catalyzed the alkylation of aldehydes by alkynyltin reagents with high Cram selectivity (equation 227) [227]. Titanium homoenolates alkylated aldehydes, producing lactones (equation 228) [228]. Titanium(IV) chloride promoted the reactions of trimethylsilyl enol ethers with aldehydes, with a high degree of stereoselectivity (equation 229) [229], (equation 230) [230]. Chiral acetals of  $\beta$ -hydroxy esters underwent reaction with nucleophilic trimethylsilyl derivatives to ultimately produce alcohols with high enantioselectivity (equation 231) [231]. Complexation of enolates with titanium was used to promote high stereoselectivity in aldol condensations (equation 232) [232]. Rhodium complexes catalyzed the reaction of aldehydes with conjugated enones (equation 233) [233] and with trimethylsilyl enol ethers (equation 234) [234].

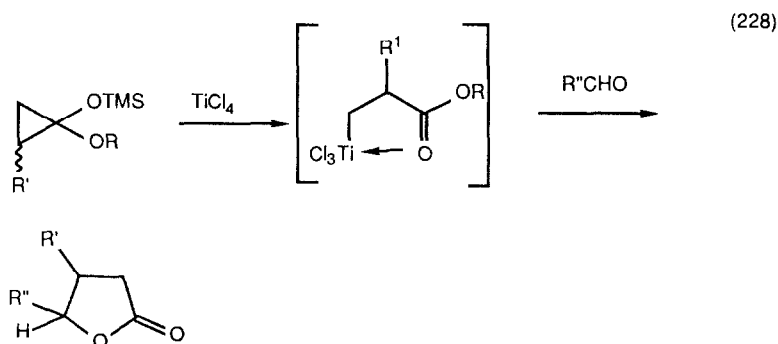
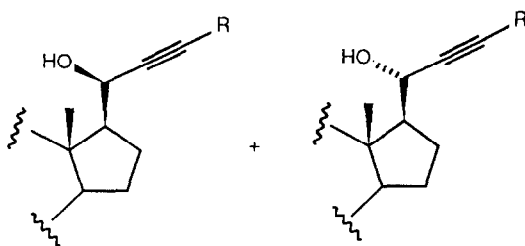
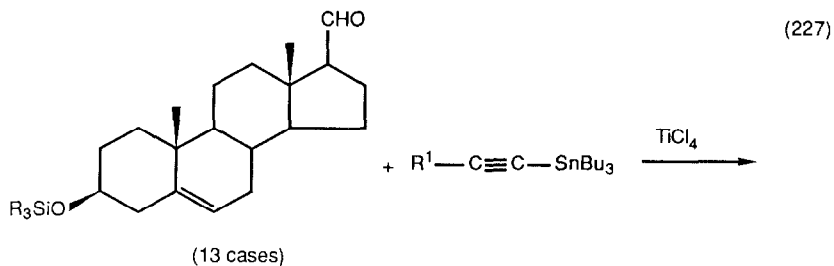

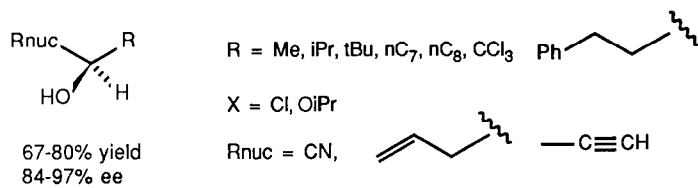
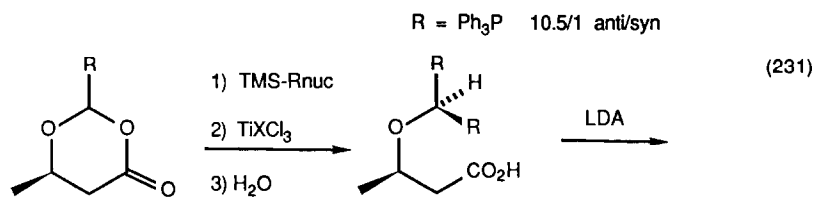
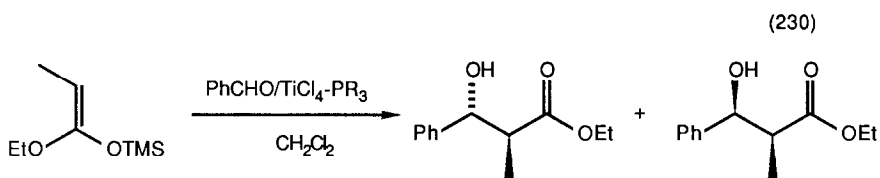
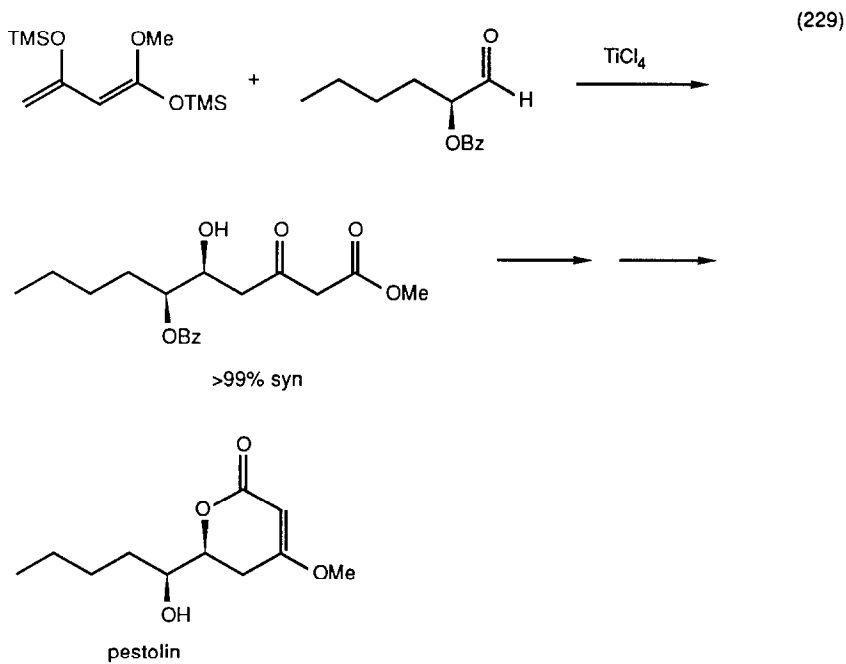

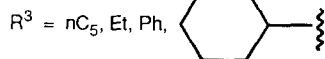
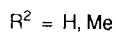
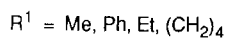
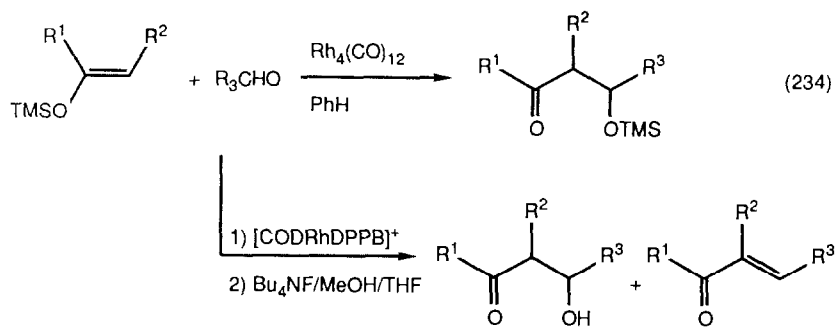
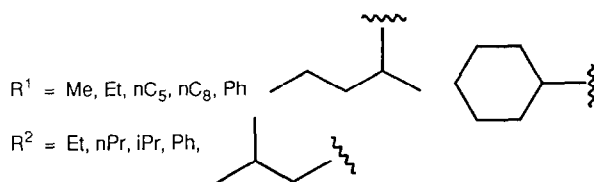
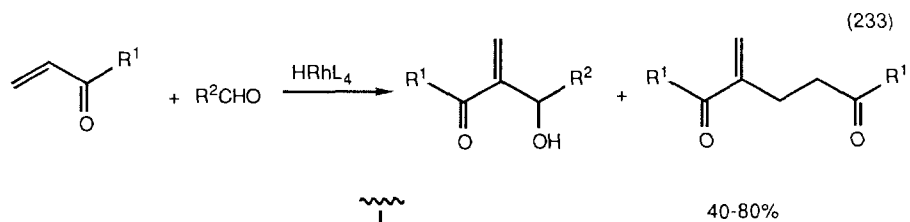
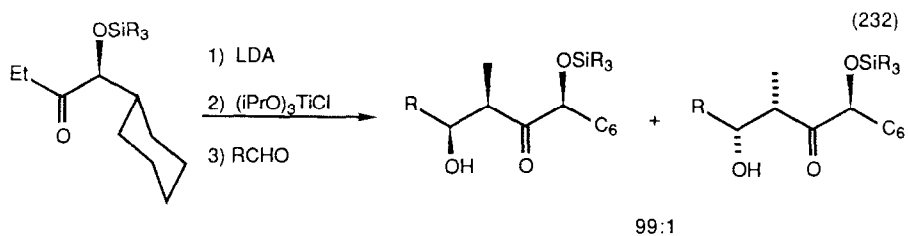



Monoalkyltitaniumtrichlorides were able to discriminate between aldehydes and ketones, and were nonbasic, so that enolizable ketones did not interfere (equation 235) [235]. Chiral titanium(IV) alkyls alkylated aldehydes with up to 90% ee (equation 236) [236]. Low valent titanium species cross-coupled ketones (equation 237) [237]. (R)-(-)-4-methylcyclohexylidene acetone coupled to acetone in the presence of titanium(O) complexes to give chiral products where as the S(+) isomer led to racemic material (equation 238) [238]. Acetylenic vanadium complexes alkynated aldehydes to ziones! (equation 239) [239]. Alkylmanganese(II) halides alkylated aldehydes in the presence of ketones (equation 240) [240]. Adjacent chelating groups activated electrophilic carbonyl groups toward reaction with transition metal organometallics (equation 241) [241].

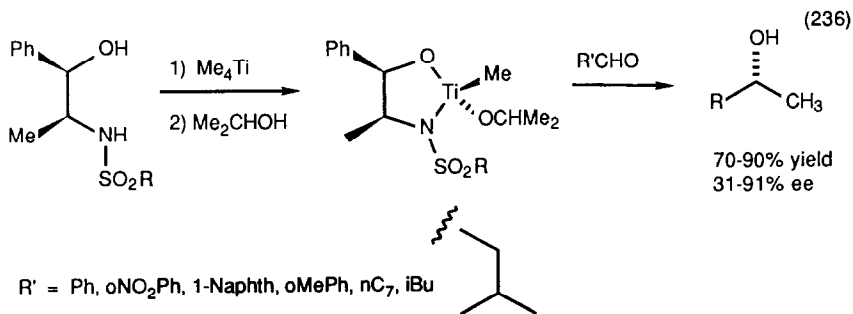
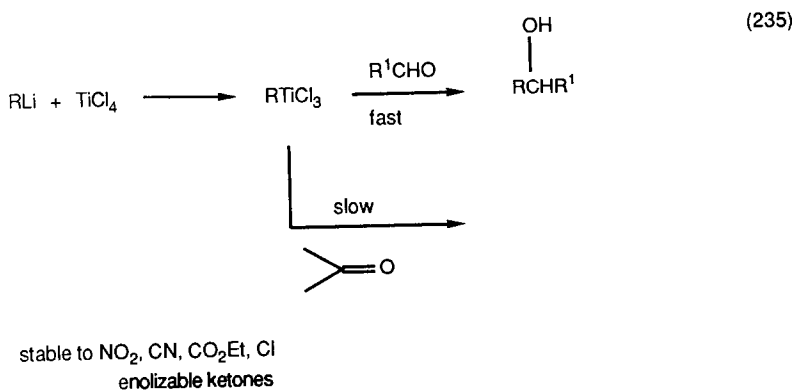

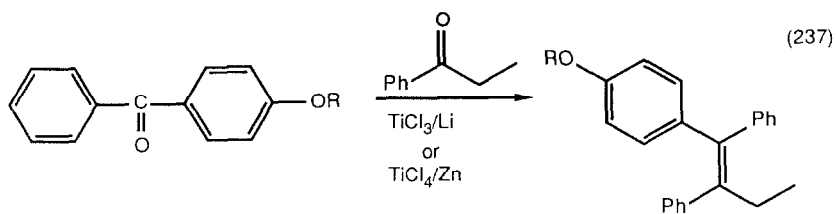

R = Me, ClCH<sub>2</sub>CH<sub>2</sub>, BrCH<sub>2</sub>CH<sub>2</sub>, CF<sub>3</sub>C<sub>6</sub>F<sub>4</sub>, Me<sub>2</sub>NCH<sub>2</sub>CH<sub>2</sub>, H

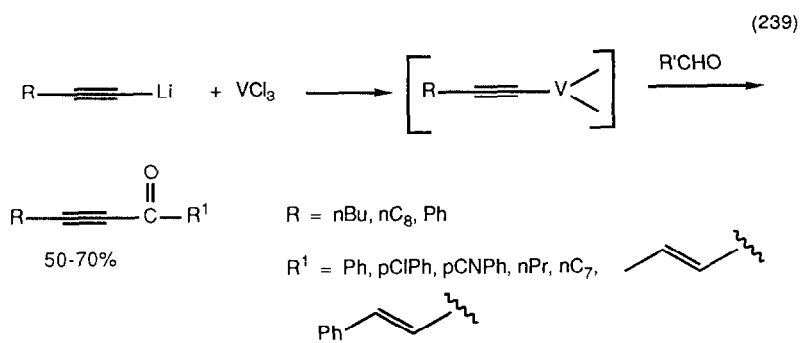
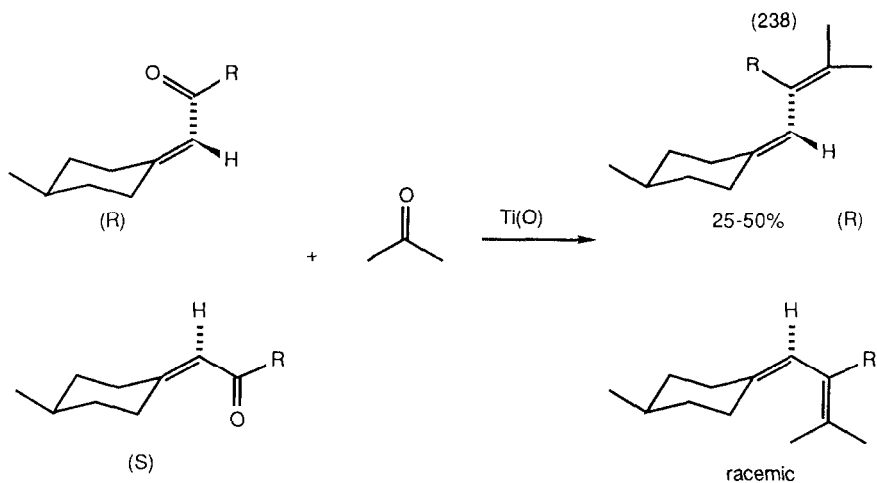

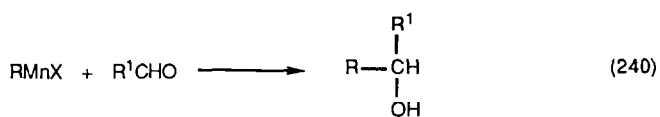

ketone inert

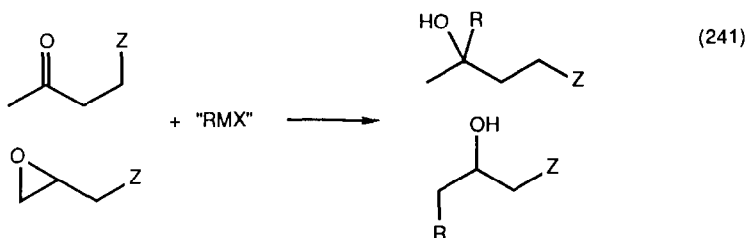
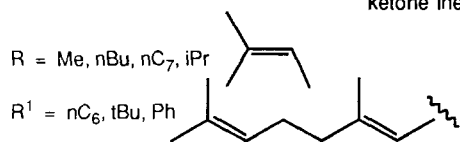

RMX = Cl<sub>3</sub>HfMe, ClV(O)Me<sub>2</sub>, Cl<sub>2</sub>CrMe, (iPrO)<sub>3</sub>TiMe, ClMnMe

Z = NMe<sub>2</sub>, OPh, OMe

Hydroxy protected glyceraldehyde was treated with vinyl trimethylsilane copper derivatives to produce homologated products with high stereoselectivity (equation 242) [242, 243], (equation 243) [244]. Organocuprates added to the C=S of the heterocycle in equation 244 [245]. Dimethyl and pentamethyl cuprates attacked 5-aldehydro-6-arylpyridazin-3-(2H)-ones at several positions (equation 245) [246].

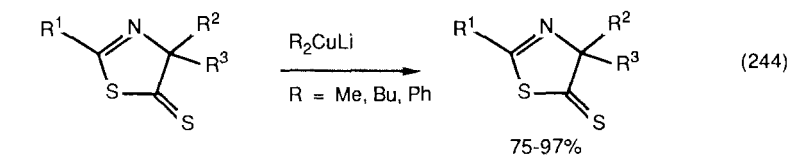
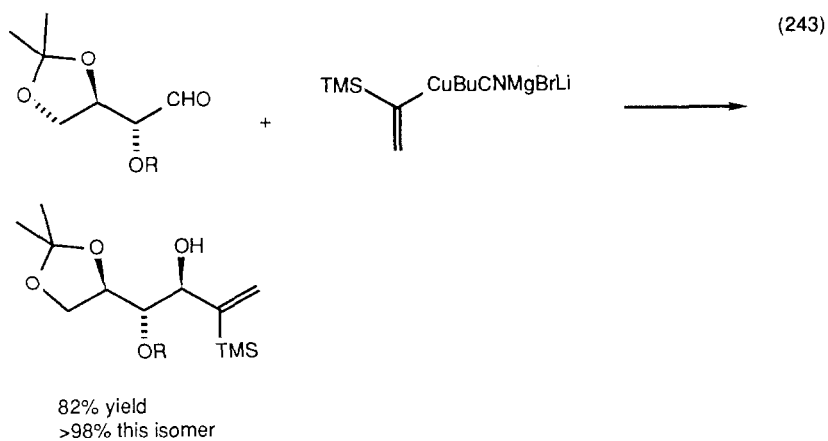
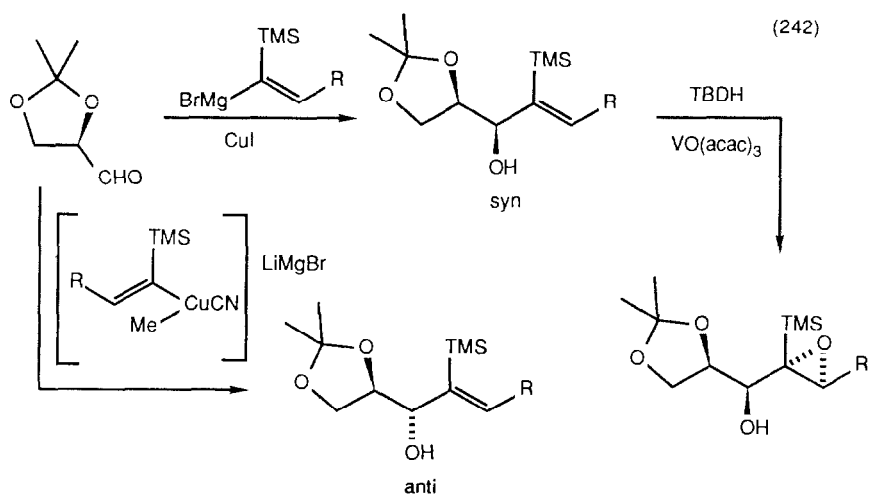

R<sup>1</sup> = Ph; R<sup>2</sup> = Me, Ph; R<sup>3</sup> = Me, Ph

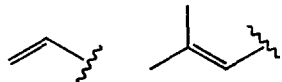

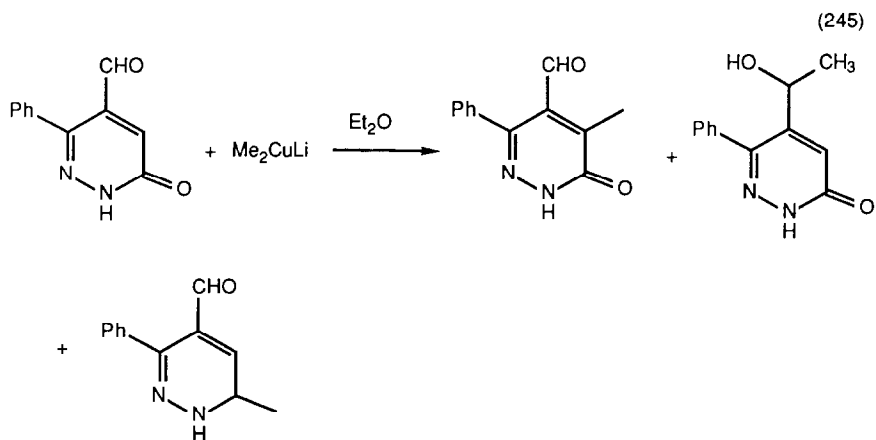

Low valent chromium effected an efficient intramolecular alkylation of an aldehyde by an allylic bromide (equation 246) [247]. Nickel(II) and palladium(II) salts catalyzed the chromium(II) reductive alkylation of aldehydes by vinyl halides (equation 247) [248]. Vinyl triflates alkylated aldehydes when treated with chromium(II) and nickel(II) salts (equation 248) [249]. Vinyl halides were prepared by the reaction of aldehydes with trihalomethanes in the presence of chromium(II) chloride (equation 249) [250].

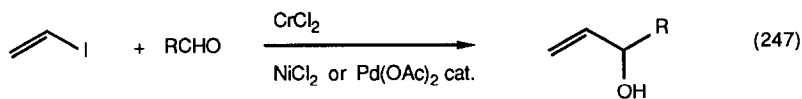
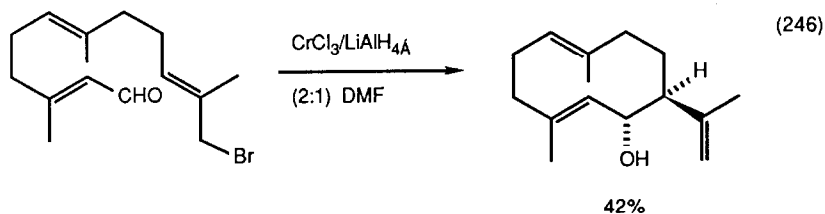

(used with highly functionalized palytoxin intermediates)

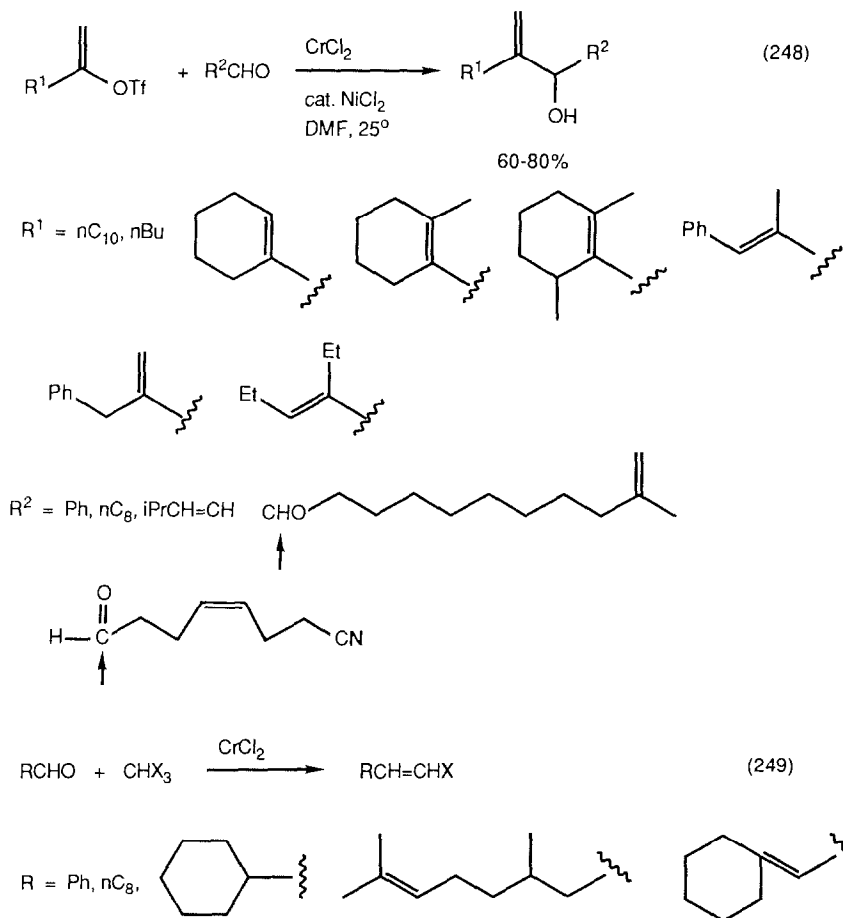

Ketones and aldehydes were allylated by allyl acetates in the presence of samarium(II) iodide and a palladium(O) catalyst (equation 250) [251]. Aldehydes were olefinated by allyl alcohol/DCC adducts or triphenylphosphine in the presence of palladium(O) catalysts (equation 251) [252], (equation 252) [253]. Chromium complexed tetralones, benzaldehyde and aryl ketones underwent alkylation at the carbonyl group by organometallation (equations 253 and 254) [254].

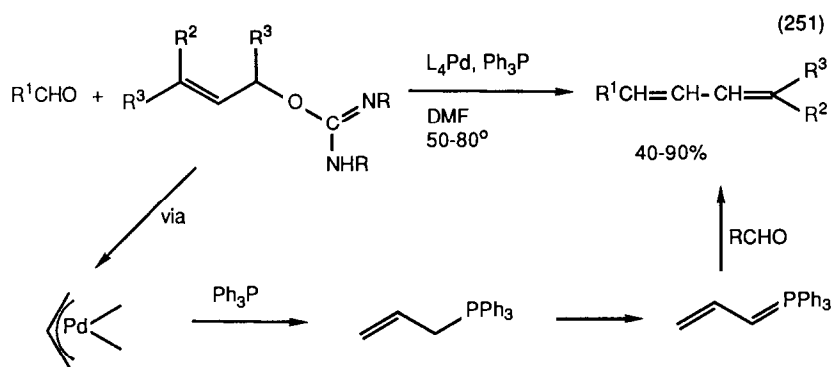
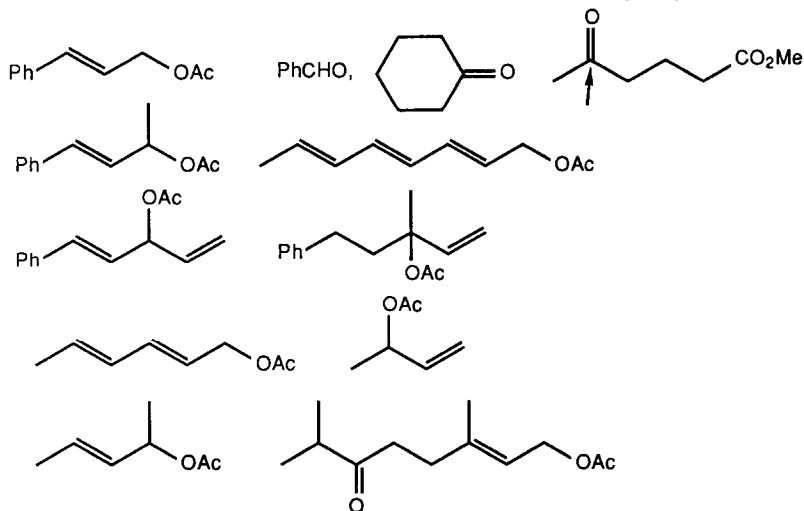
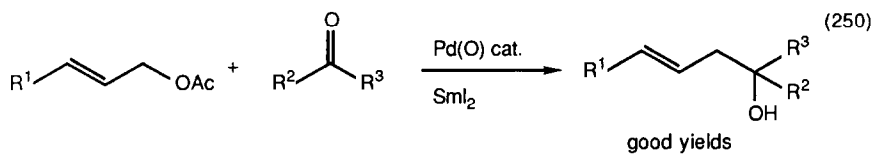

$R^1 = Ph, nPr; R^2 = H, Me; R^3 = H, Me, nPr, Ph, nC_6, geranyl$

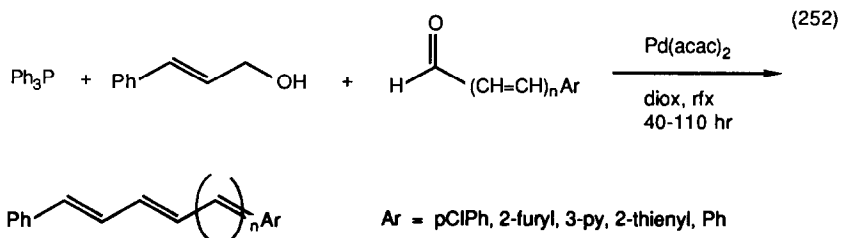

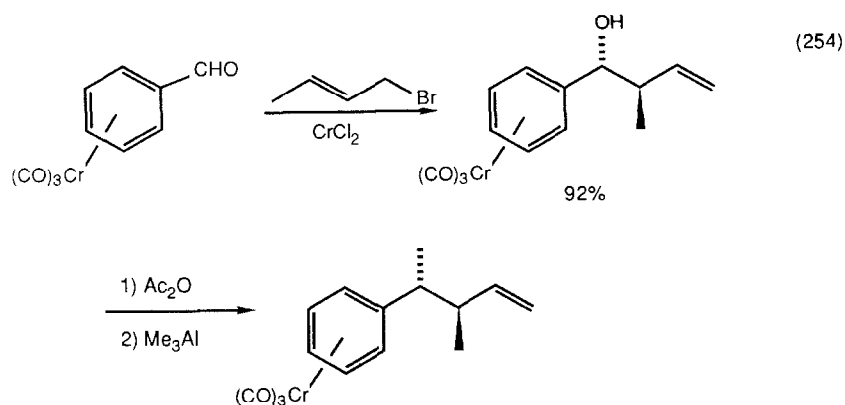
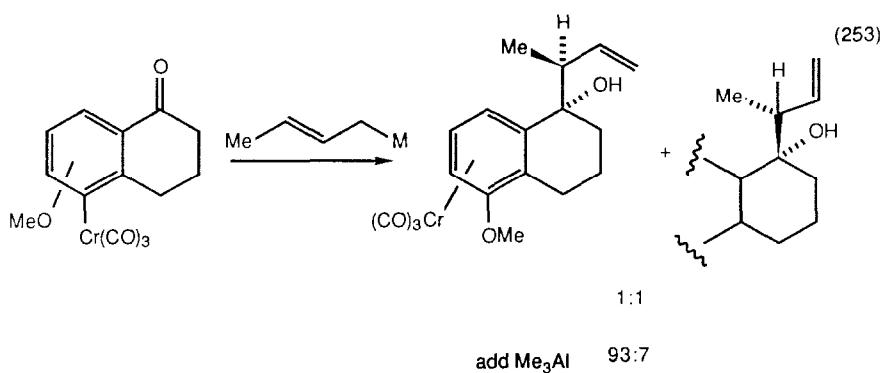

### 11. Alkylation of Aromatic Compounds

Recent advances in arene transformation reactions via chromium complexes have been reviewed (36 references) [255]. Isoquinoline alkaloids were ring-functionalized by complexation to chromium followed by lithiation/electrophile reaction (equation 255) [256]. Chromium-complexed fluororenes were lithiated and then allowed to react with electrophiles. The fluorine directed the lithiation ortho (equation 256) [257], (equation 257) [258]. With nucleophiles, fluorines on chromium-complexed arenes were selectively replaced [259]. Conformationally restricted arenechromium tricarbonyl complexes underwent nucleophilic attack at carbons eclipsed by a chromium carbonyl bond and electrophilic attack at carbon atoms in the staggered position [260].



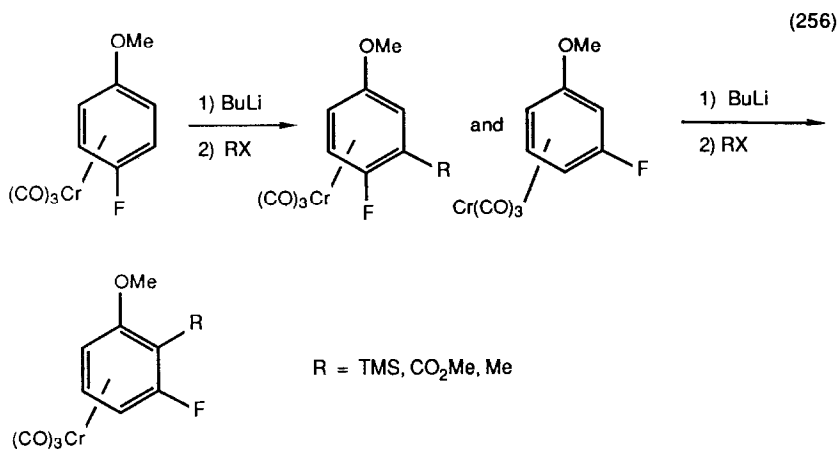
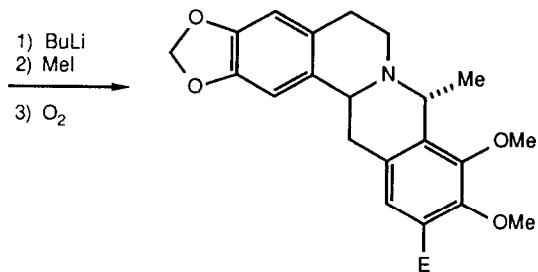
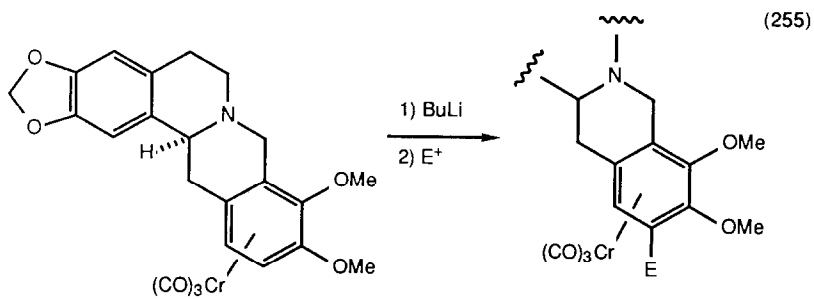

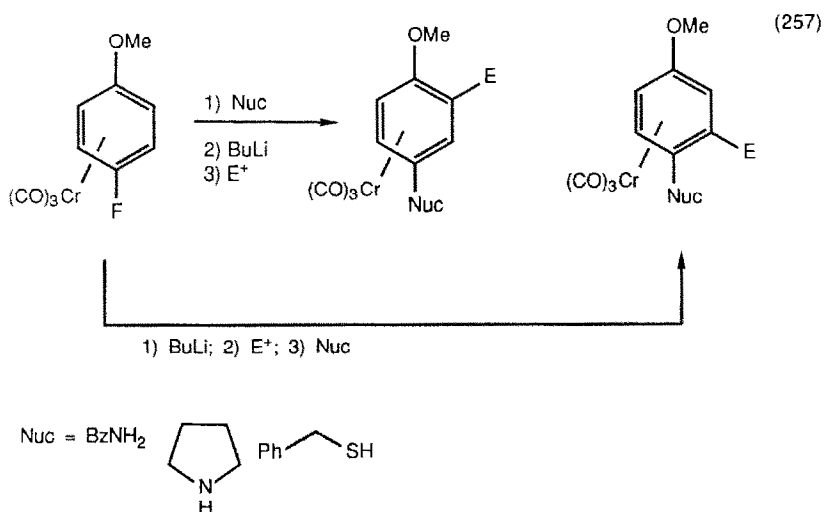

Chlorobenzenes complexed to chromium tricarbonyl underwent displacement by methoxide under phase transfer conditions [261]. Unusual hydrogen shifts were noted in additions of nucleophiles to arenechromium tricarbonyl complexes (equation 258) [262], (equation 259) [263].

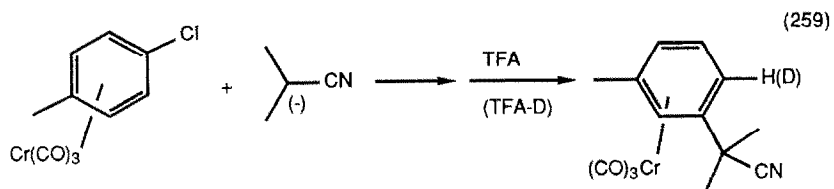
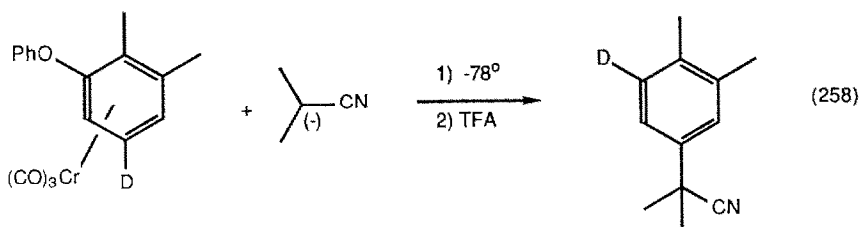

Activation of benzylic positions by arene complexation to chromium has also become popular. Treatment of chromium tricarbonyl complexes of benzyl alcohol with  $\text{HBF}_4 \cdot \text{OME}_2$  generated a stabilized benzyl cation that was generally reactive toward nucleophiles (equation 260) [264]. Complexed benzyl ethers underwent similar activation (equations 261 and 262) [265]. The stereochemistry of attack on the benzylic position was controlled by the ring position of a trimethylsilyl group (equations 263 and 264) [266]. This chemistry was used to synthesize a relay to acorenone (equation 265) [267].

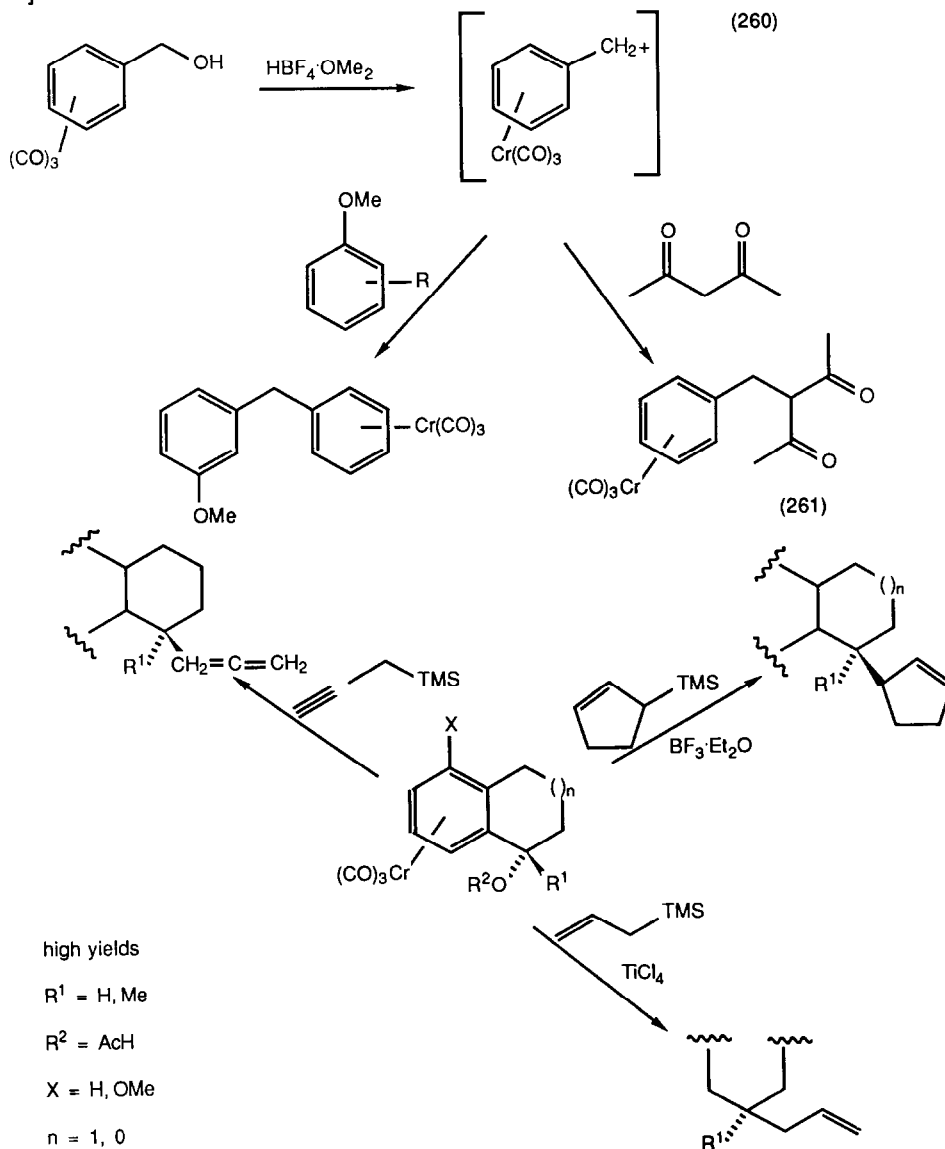

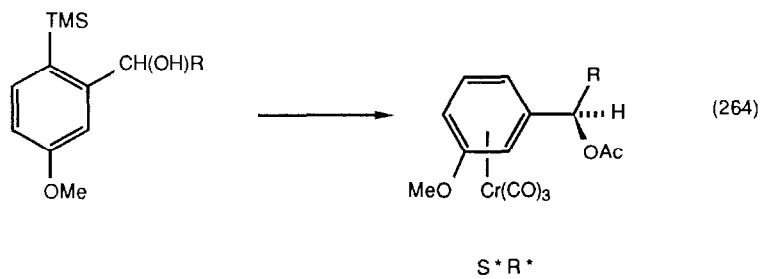
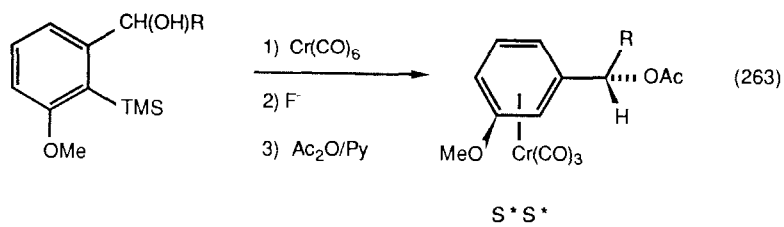
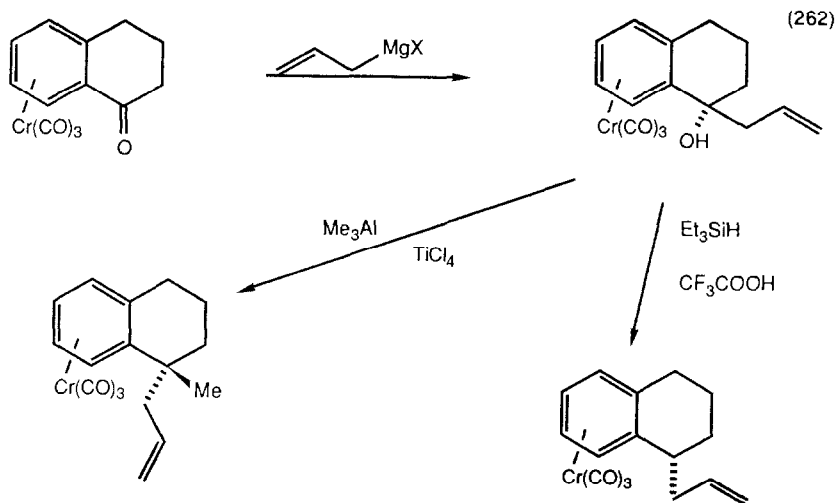

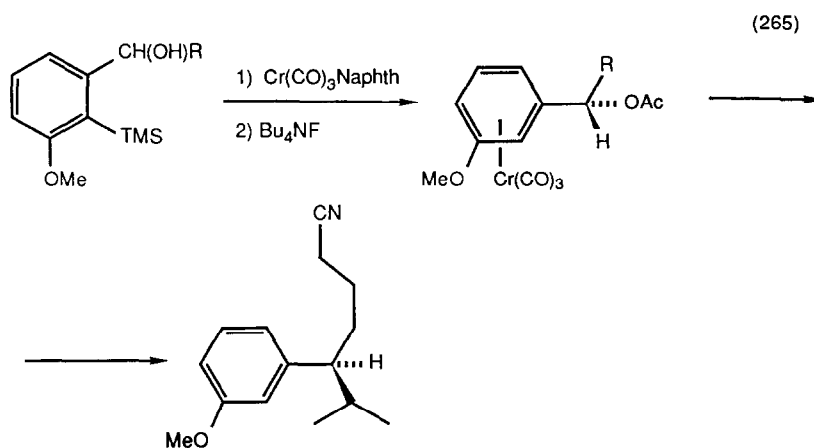

Chromium complexed allyl benzenes underwent  $\gamma$ -alkylation by aldehydes under basic conditions (equation 266) [268]. Remote substituents on complexed arene rings directed the site of benzylic deprotonation (equation 267) [269], (equation 268) [270]. Resolved, chromium complexed *o*-methyl benzaldehyde underwent reductive amination-alkylation with high ee (equation 269) [271].

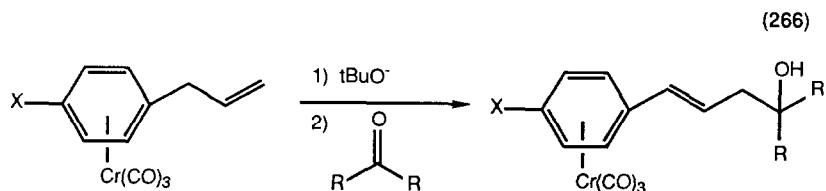

X = H, OMe

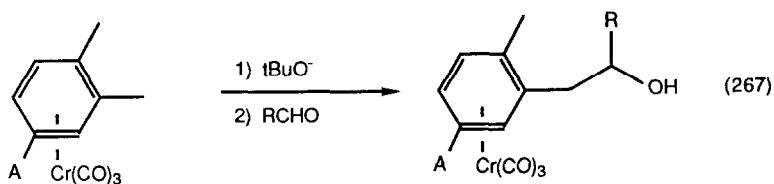

A =  $\text{Me}_2\text{N}$ , MeO, Cl,  $\text{CO}_2\text{tBu}$  - all direct to  $\text{III}$  methyl

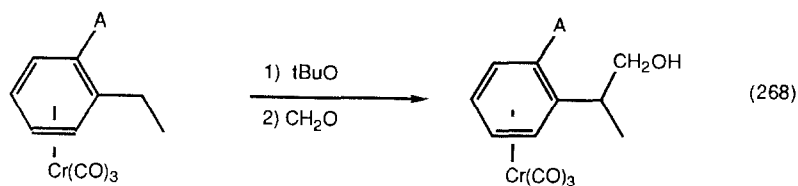

A = OMe, OiPr, NMe<sub>2</sub>, NEt<sub>2</sub>

88-100% diastereoselective

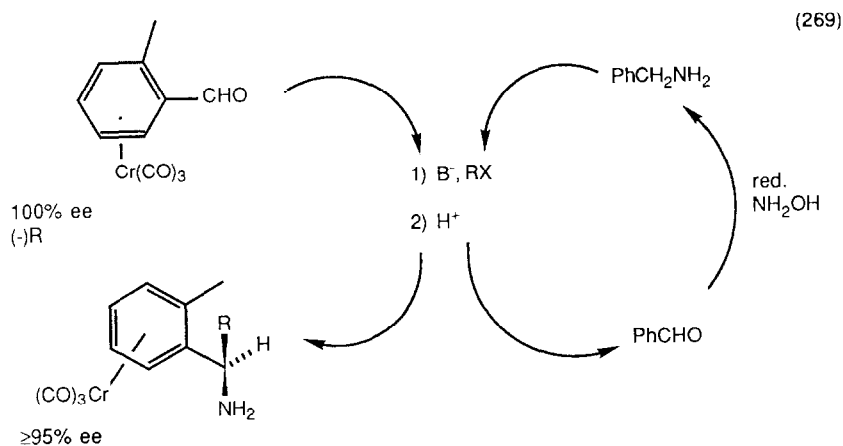

Cationic manganese arene complexes underwent alkylation by Grignard reagents (equation 270) [272]. Bis(hexamethylbenzene)iron<sup>2+</sup> was functionalized by the process shown in equation 271 [273]. 1,2-Disubstituted cyclohexadienes were prepared this way (equation 272) [274].

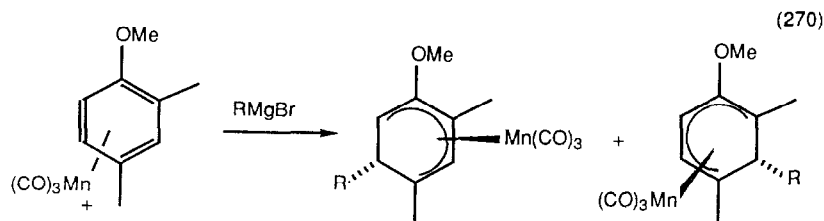

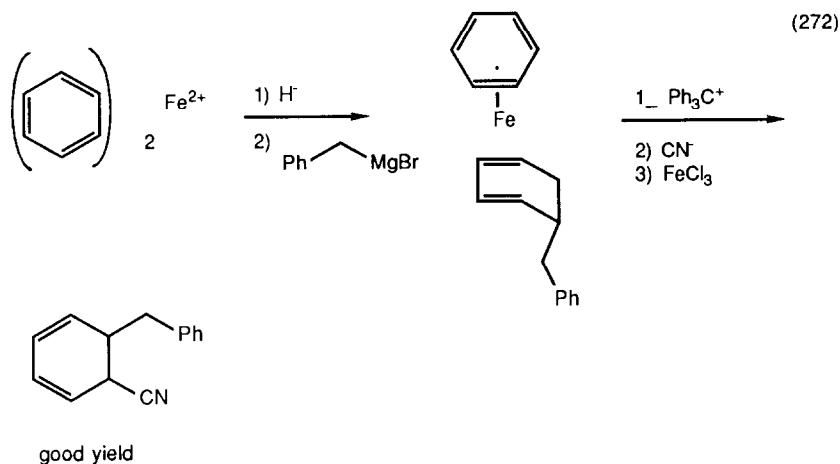
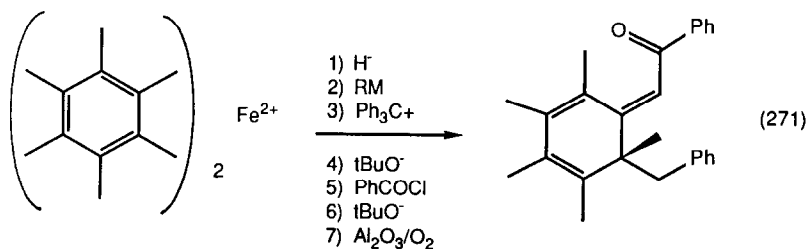

## 12. Alkylation of Dienyl and Diene Complexes

Regioselectivity in nucleophilic addition to diene-iron complexes was the topic of a dissertation [275]. Reduced nickel species catalyzed the addition of nucleophiles to 1,3-cyclohexadiene (equation 273) [276]. 2-Formylbutadiene iron tricarbonyl complexes were resolved, and were alkylated at the formyl group (equation 274) [277]. The aldehyde group of this complexed diene was also converted to its dithiane and subjected to normal dithiane chemistry (equation 275) [278].

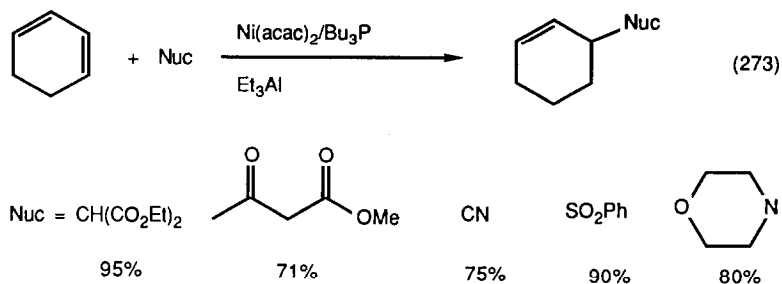

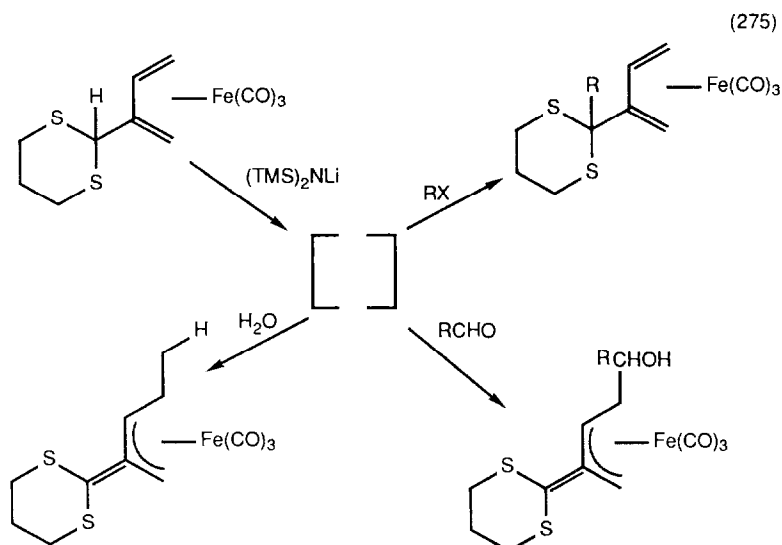
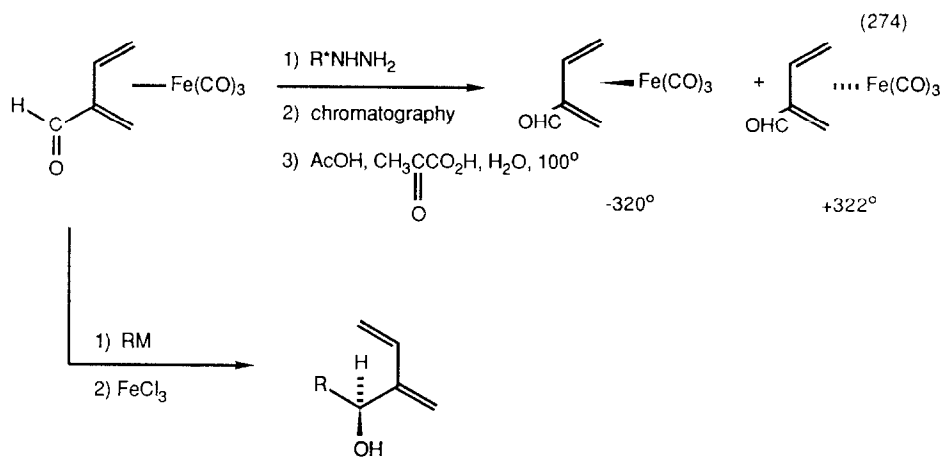

Cyclohexadienyliron tricarbonyl complexes figured extensively in the synthesis of 3,14-dihydroxytrichothecane (equation 276) [279] and bridged polycyclic alkaloids (equation 277) [280]. Trimethylsilyl cyanide proved superior to sodium cyanide for the introduction of CN into cyclohexadienyl iron complexes (equation 278) [281]. Chiral carbanions alkylated cycloheptadienyl iron complexes with up to 50% ee (equation 279) [282]. Cyclohexadienyliron tricarbonyl complexes were effective nucleophiles for the alkylation of  $\eta^3$ -allylmolybdenum anones (equation 280) [283].



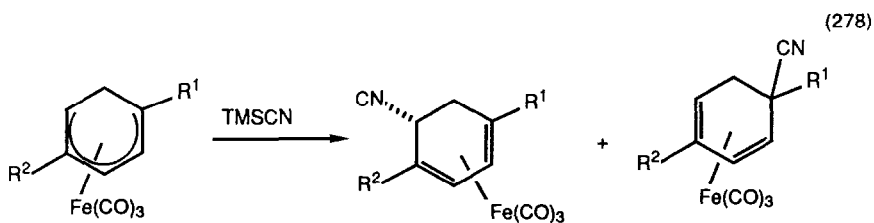
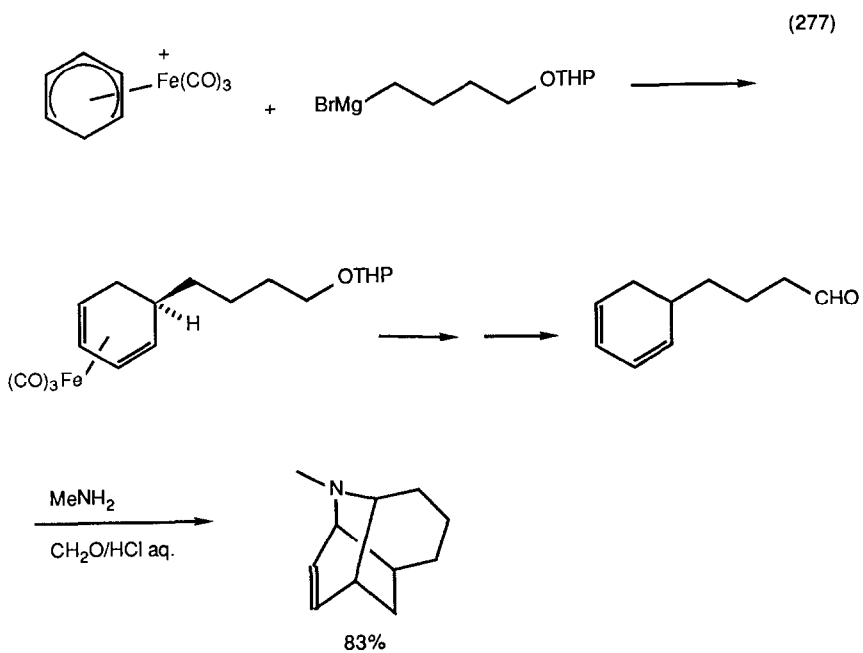
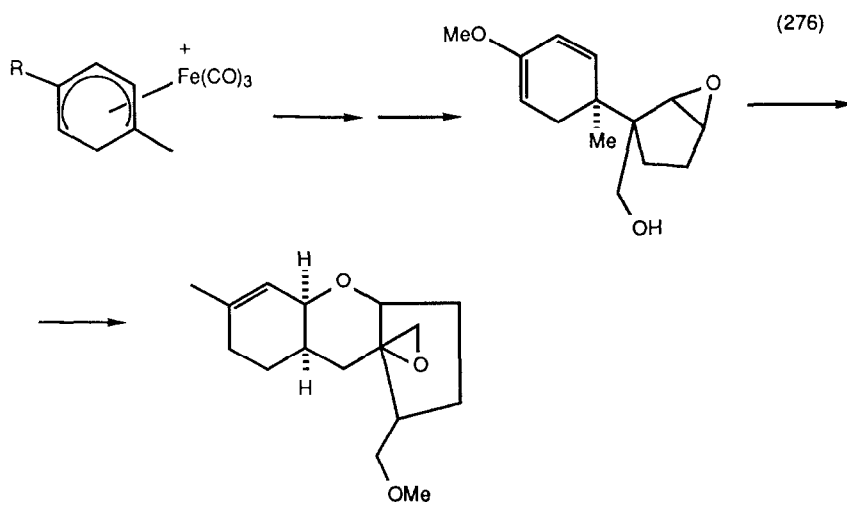

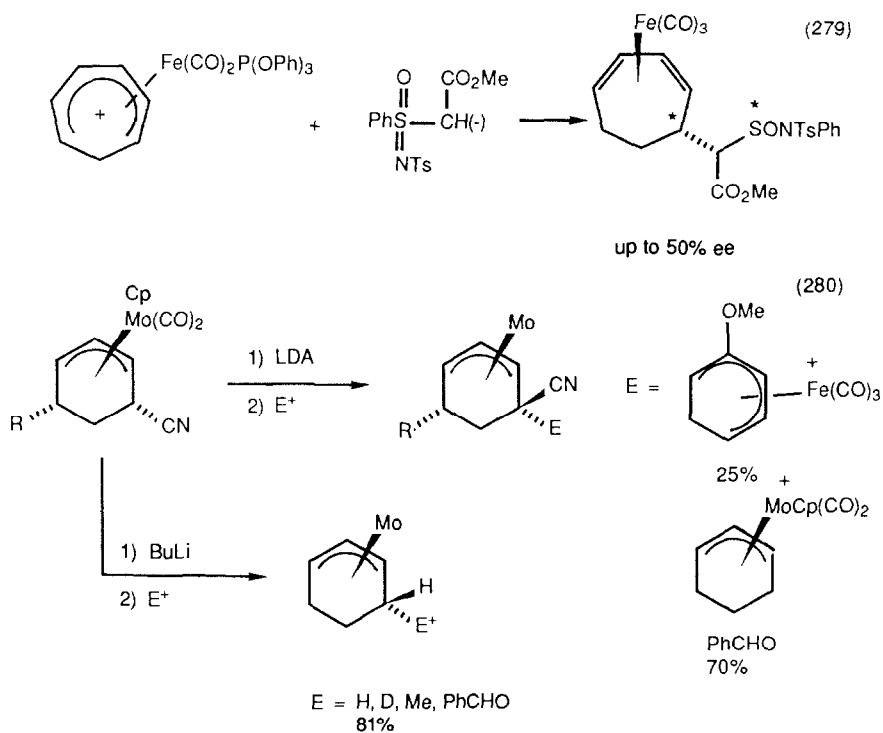

Rhodium(I) complexes catalyzed the condensation of allenes with 3-butenic acids (equation 281) [284]. Ruthenium(O) complexes catalyzed the 1,4-addition of terminal alkynes to dienes (equation 282) [285]. Silylmanganese complexes added to dienes (equation 283) [286].

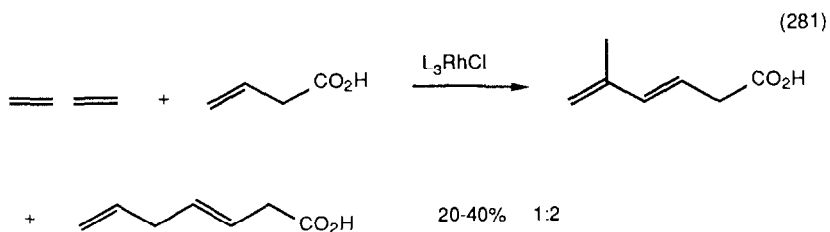

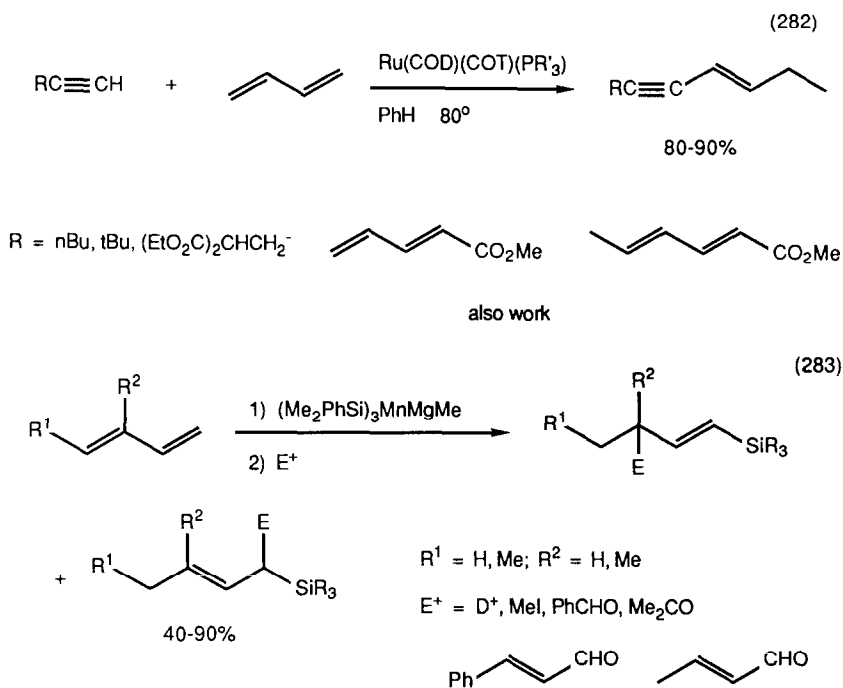

### 13. Metal-Carbene Reactions

Electrophilic metal carbenes as reaction intermediates in catalytic reactions has been reviewed (52 references) [287], as has catalytic methods for metal carbene transformations (159 references) [288]. Fisher type carbenes have been made directly from tungsten hexacarbonyl and alkynes (equation 284) [289]. "Four membered rings from isocyanides-recent advances" was the title of a review (125 references) which included the reactions shown in equations 285 and 286 [290].

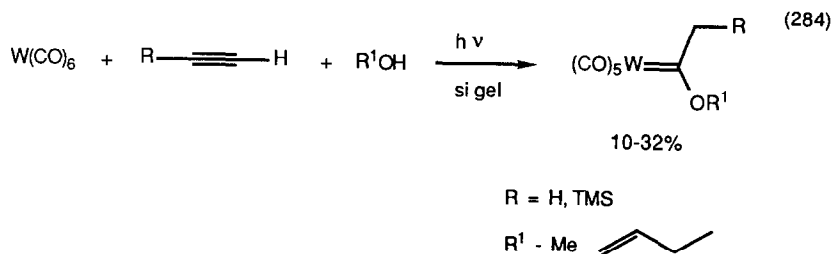

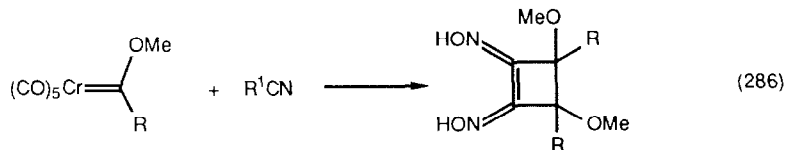
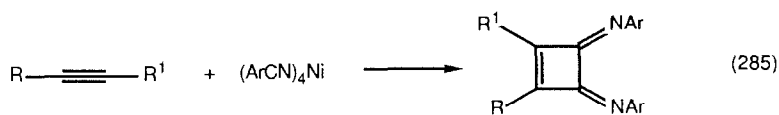

The D-ring of steroids was annulated in modest yields using the alkyne-chromium carbene reaction (equation 287) [291]. Carbenes of tetramethyl acetals of quinones behaved anomalously (equations 288 and 289) [292]. The steric and electronic effects of alkyne substitution on the "Dötz" naphthohydroquinone synthesis from chromium carbenes and alkynes was studied in detail (equation 290) [293]. A bis chromium carbene complex thermolyzed to a bis enol ether (equation 291) [294]. Diynes underwent reaction with metal carbynes to produce phenols [295].

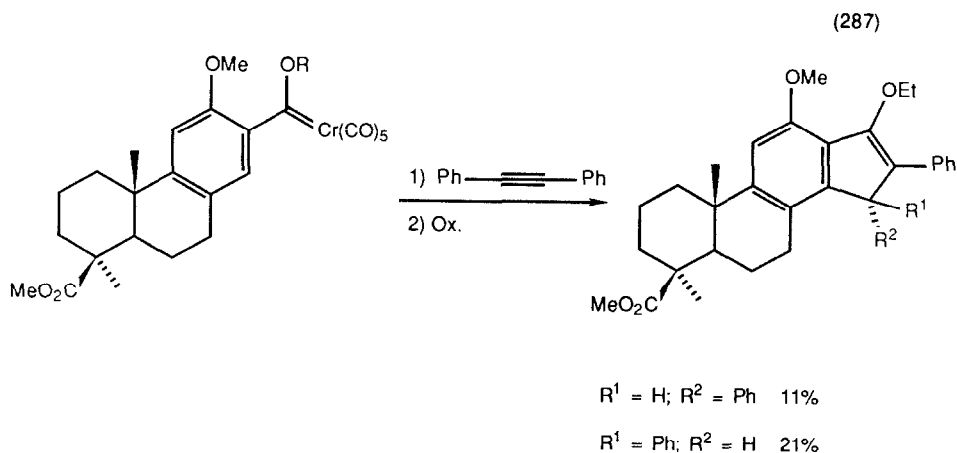

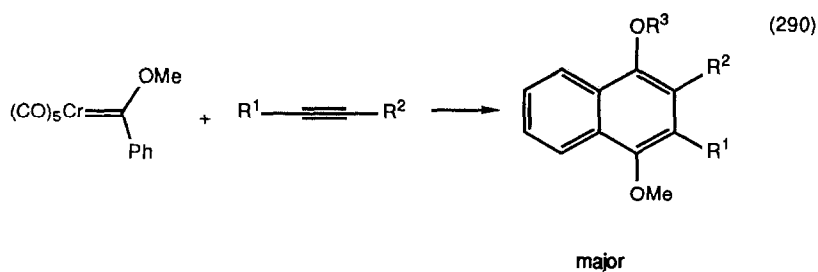
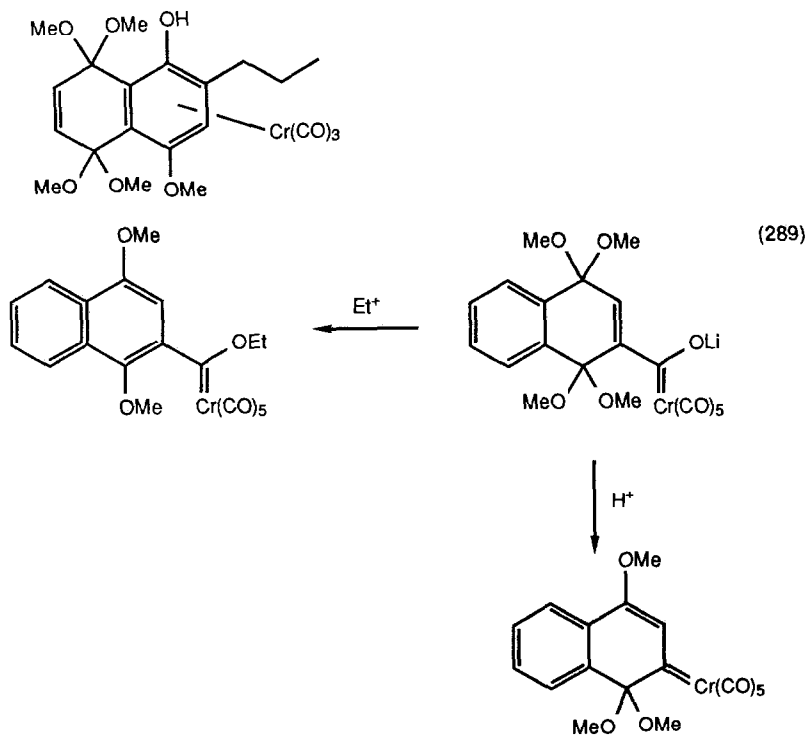
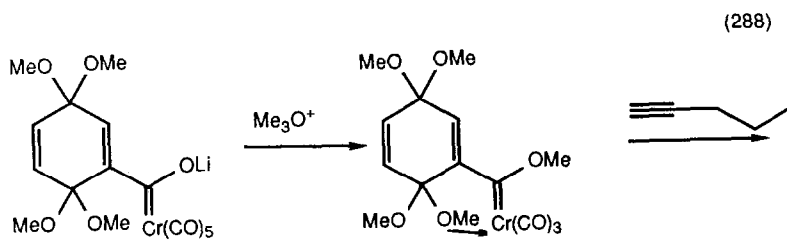

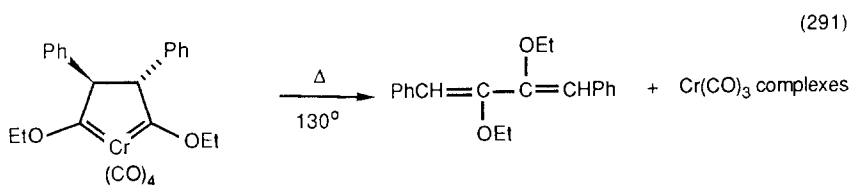
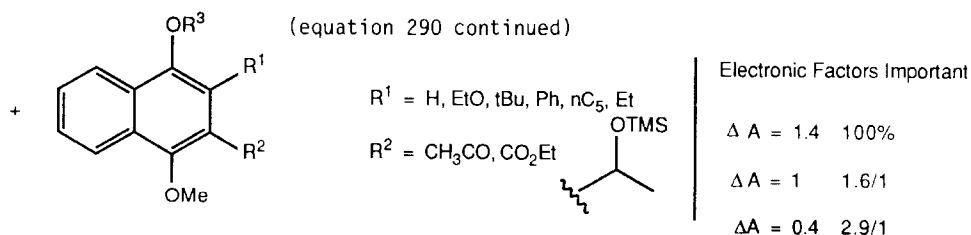

Acetylenic carbyne complexes underwent a 1,3-dipolar cycloaddition with diazoalkanes to produce heterocyclic carbenes, which underwent typical carbene reactions (equation 292) [296]. Aminocarbenes underwent thermal reaction with alkynes to give indenones or 1-aminoindenones (equation 293) [297]. Indenes (equation 294) and cyclobutenones (equation 295) were also available from chromium carbenes [298]. Cobalt carbenes underwent reaction with alkynes to give furans (equations 296 and 297) [299].

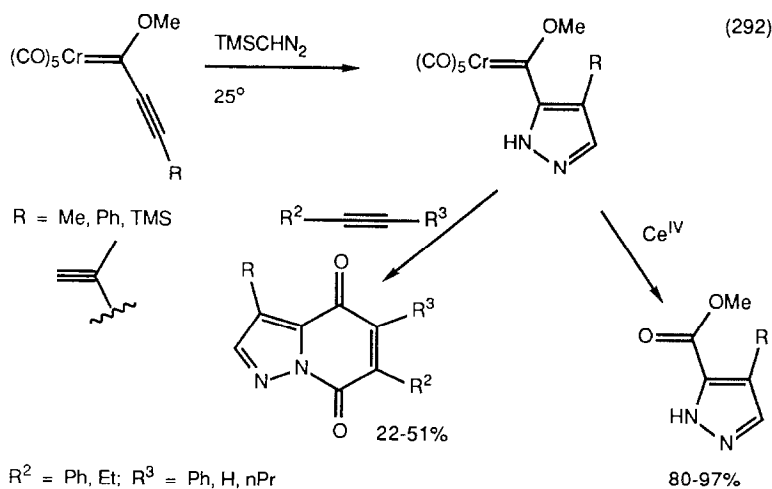

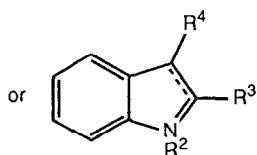
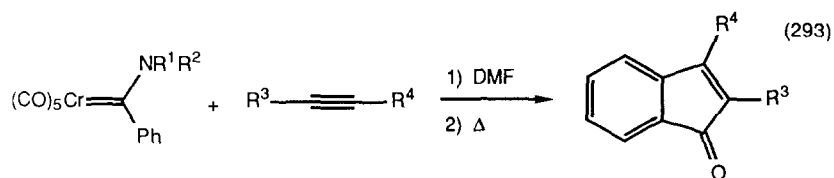

$\text{R}^3 = \text{H, Et, CO}_2\text{Et, Me, Ph}$

$\text{R}^4 = \text{Bu, Et, Ph}$

good yields

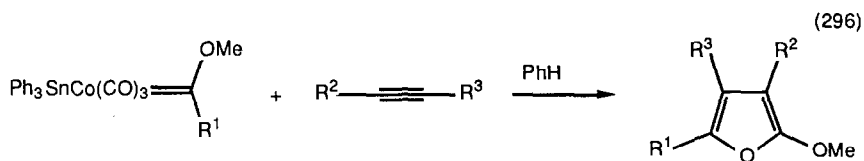
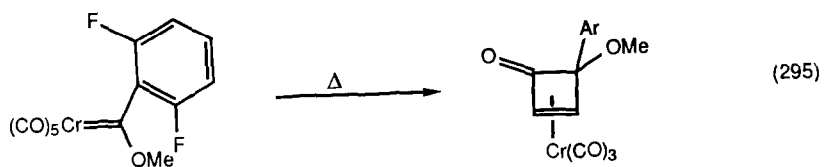
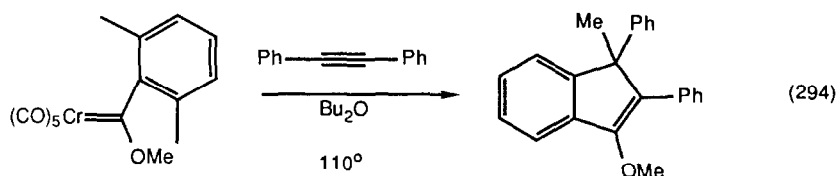

$\text{R}^1 = \text{Ph}$	$\text{R}^2 = \text{Et}$ 93%
Ph	Ph 58
Ph	Me 75
Bu	Ph 39

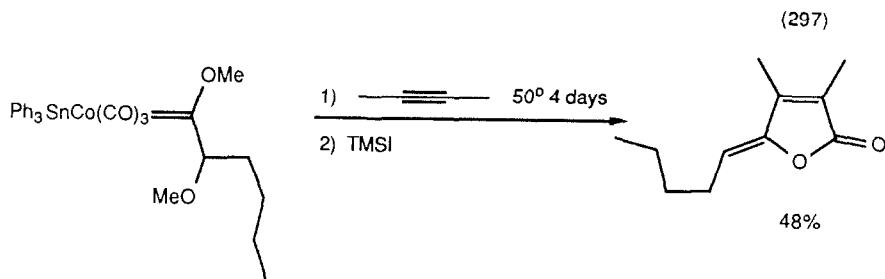

Methylenations with Tebbe-Grubbs reagents has been reviewed (16 references) [300]. Eight membered lactones were methylenated to enol ethers by the Tebbe reagent (equation 298) [301]. Alkynes, phenyllithium and titanocene dichloride combined to produce trisubstituted alkynes via titanacycles [302]. Capnellene was synthesized using titanium carbenes as key intermediates (equation 299) [303]. The reagents  $\text{Cl}_2\text{CrMe}(\text{THF})_3$ ,  $\text{ClMo}(\text{O})=\text{CH}_2$ , and  $\text{Cl}_2\text{Mo}(\text{Me})=\text{CH}_2$  did not react with acid chlorides or anhydrides [304]. Tungsten oxo carbenes efficiently methylenated ketones and aldehydes (equations 300 and 301) [305]. Reaction of these with trimethylaluminum also produced reagents that methylenated aldehydes and ketones but not esters (equations 302 and 303) [306].

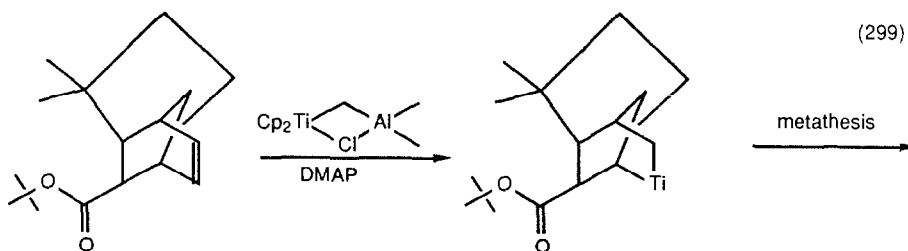
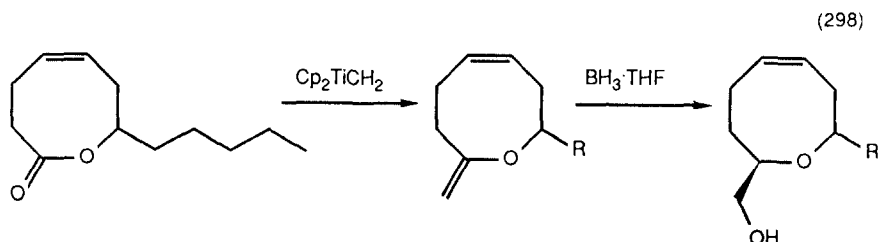



(equation 299 continued)

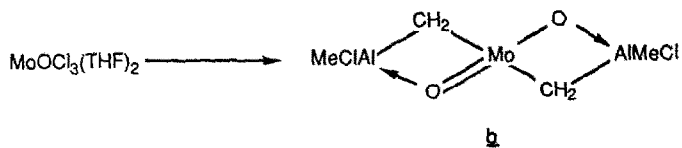
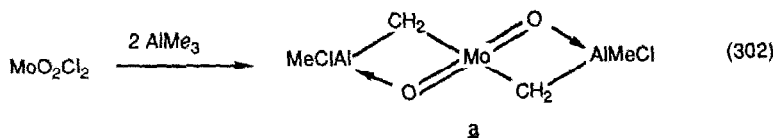
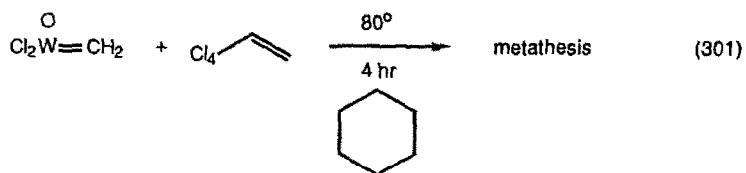
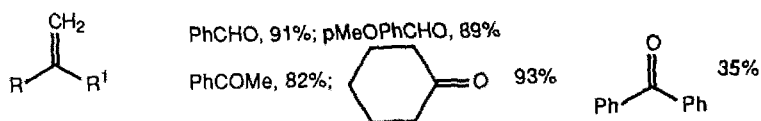
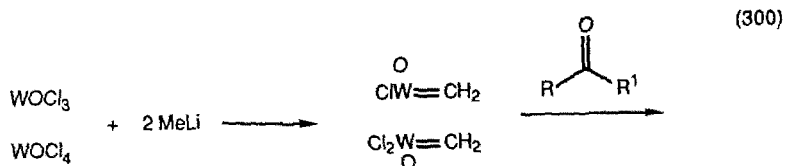
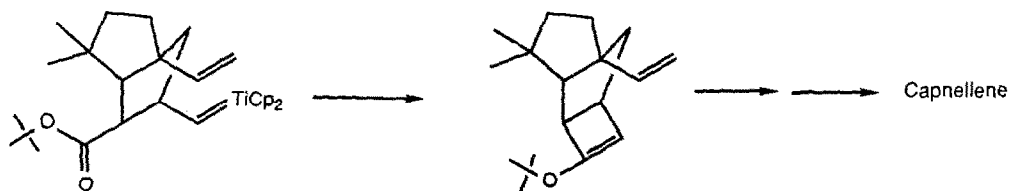

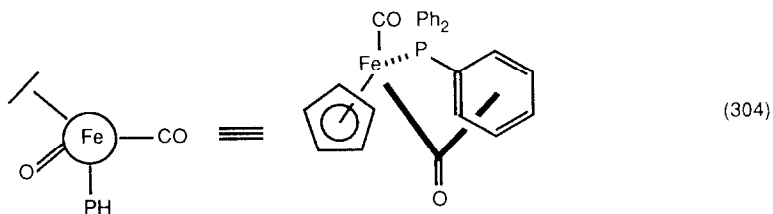
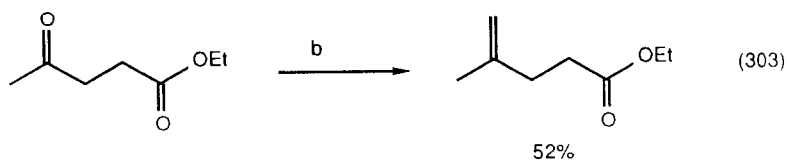

#### 14. Alkylation of Metal Acyl Enolates

The use of acyliron enolates to control stereochemistry in enolate alkylation has found extensive application. Hückel and *ab initio* SCFMD calculations have shown that this stereocontrol arises because the acyl carbonyl group is *anti* periplanar to the CO group on iron due to interaction with two of the phenyl groups on the phosphonium (equation 304) [307]. An increase in the size of the electrophile resulted in an increase in stereoselectivity of the alkylation of iron enolates [308].  $\alpha,\beta$ -Unsaturated acyliron complexes were  $\gamma$ -deprotonated and  $\alpha$ -alkylated with a high degree of stereocontrol (equation 305) [309].

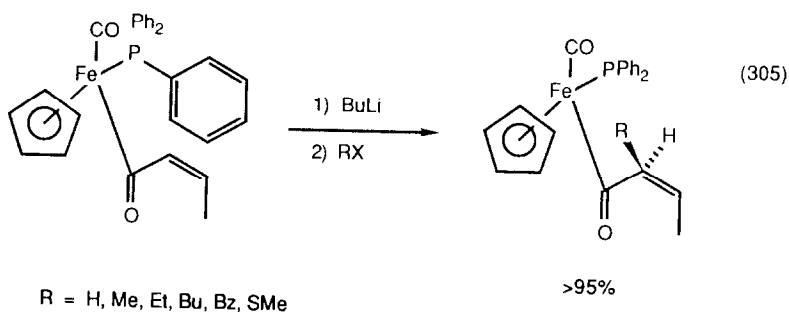

The full experimental details on the use of acyliron enolates in the synthesis of  $\beta$ -lactams has appeared (equation 306) [310], (equation 307) [311][312]. Extensions of this alkylation chemistry have also appeared (equation 308) [313]. In some cases, decomposition of the acyliron enolate to the ketene was observed (equation 309) [314].

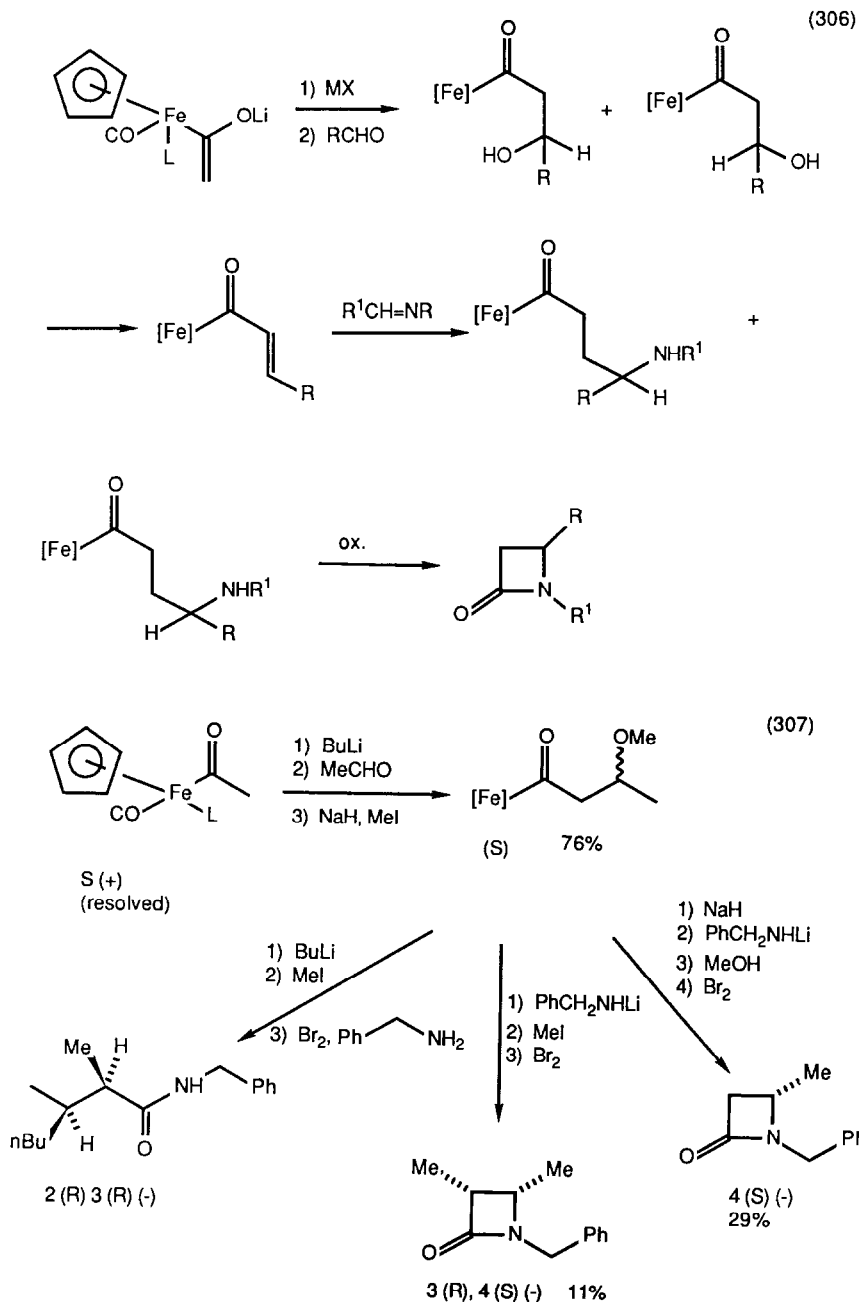

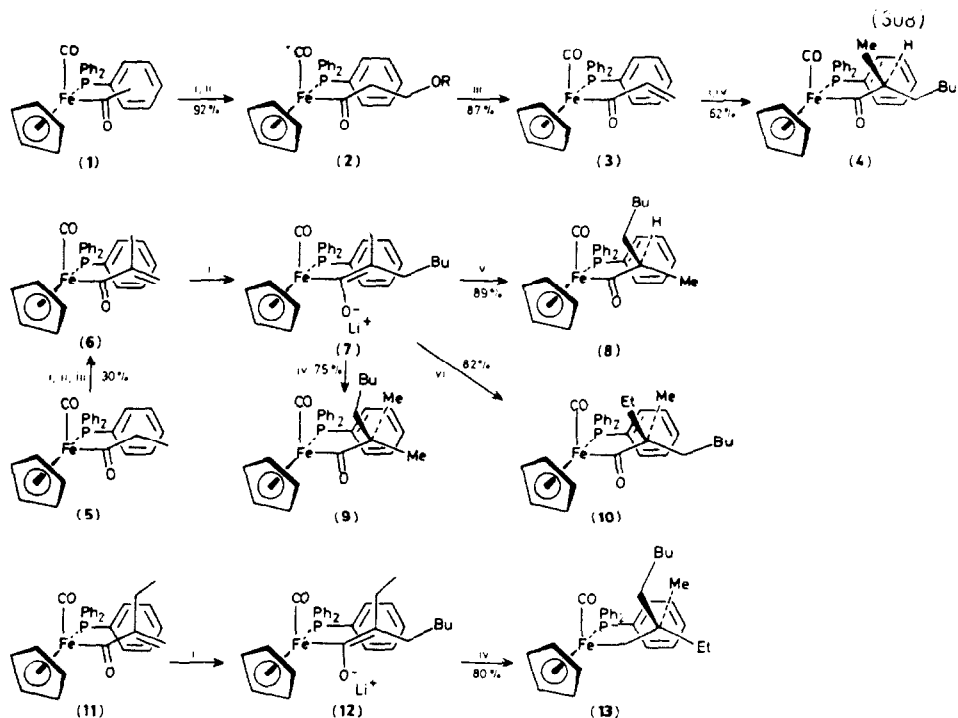

Reagents: i.  $Bu^oLi$ , tetrahydrofuran (THF),  $-78^\circ C$ ; ii.  $ClCH_2OR$  ( $R = Me, menthyl$ ),  $-40^\circ C$ ; iii.  $NaH$ , THF,  $50^\circ C$ ; iv.  $MeI$ ,  $-78^\circ C$ ; v.  $MeOH$ ,  $-100^\circ C$ ; vi.  $EtI$ ,  $-78^\circ C$ .

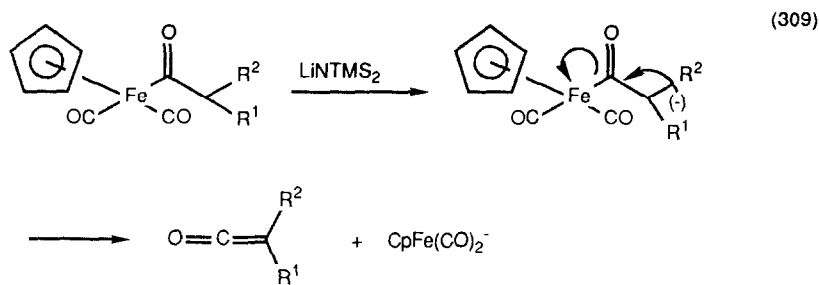

Diels-Alder reaction to  $\alpha, \beta$ -unsaturated acyliron complexes have also been carried out (equation 310) [315], (equation 311) [316]. Again, starting with resolved chiral acyliron species, high asymmetric induction was observed (equation 312) [317].

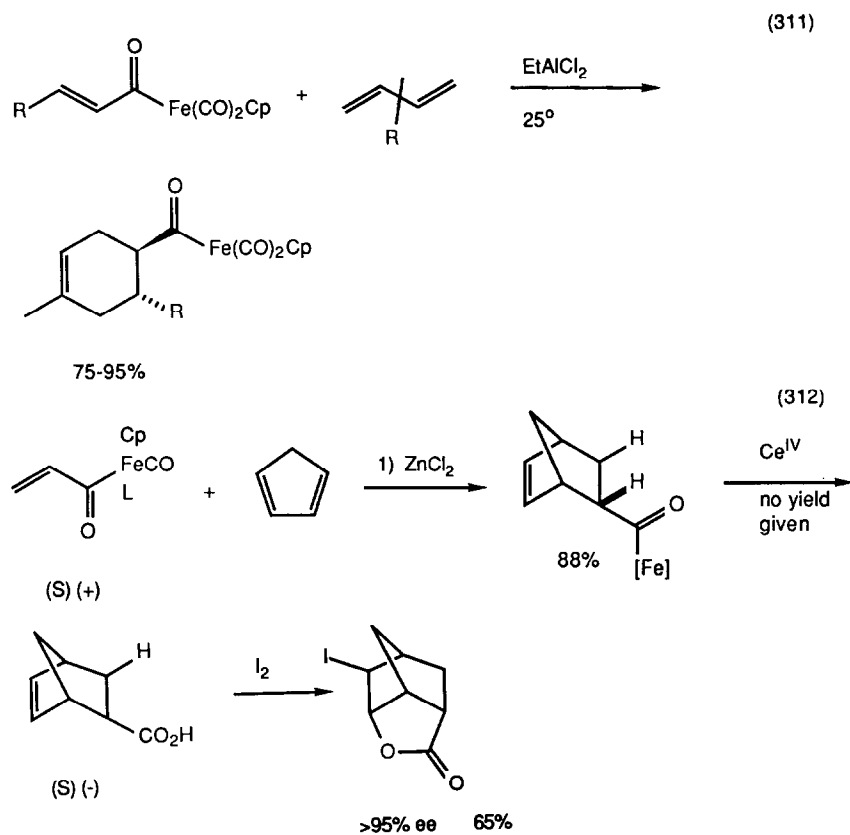
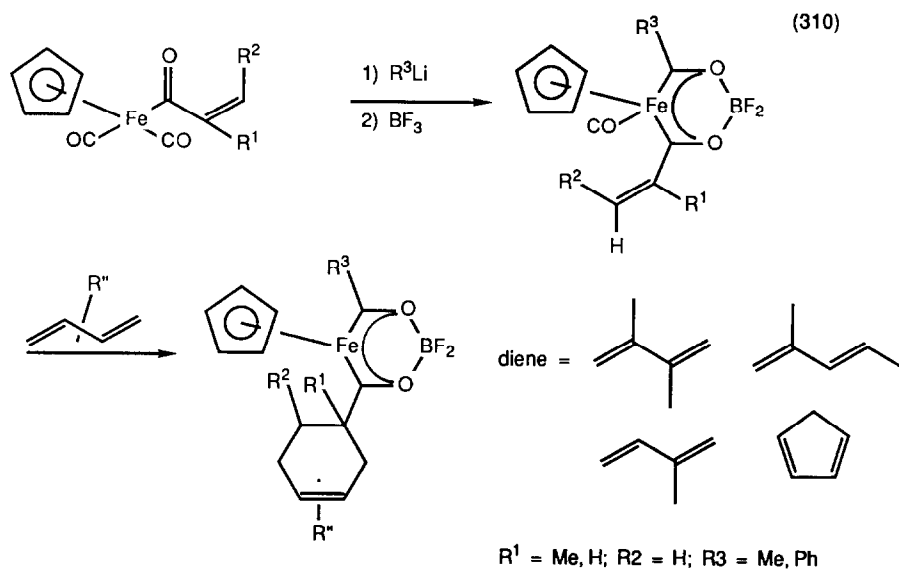

Sequential reduction-insertion-reduction processes on cyclopentadienyliron carbonyl compounds produced pentanoic acid in which all five carbons were carbon-monoxide derived (equation 313) [318]. Synthesis and carbon-carbon bond forming reactions of tungsten, molybdenum, and rhenium enolates has been reviewed [319]. Molybdenum enolates were  $\alpha$ -alkylated (equation 314) [320].

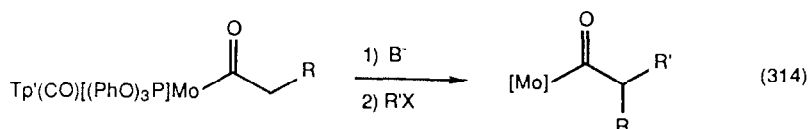
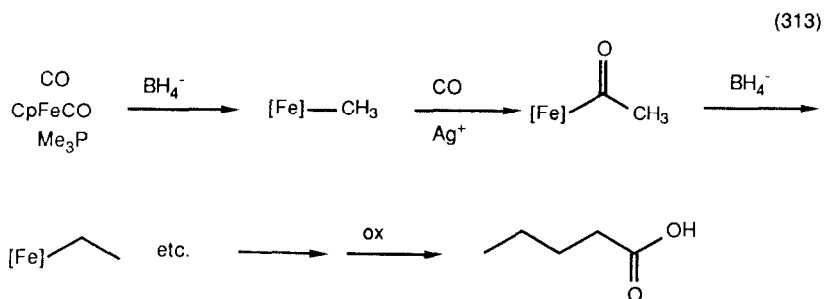

### B. Conjugate Addition

"Conjugate additions of nonterminal vinylic organocuprates to  $\alpha,\beta$ -ethylenic carbonyl compounds" was the subject of a dissertation [321]. Copper assisted conjugate alkylations continue to be used in the synthesis of prostaglandins (equation 315) [322].  $\beta$ -functionalized cyclohexenones (equation 316) [323] and capnellenes (equation 317) [324]. With  $\alpha,\beta,\gamma,\delta$ -unsaturated aldehydes, 1,2- and 1,4-addition were observed, but not 1,6 (equation 318) [325]. Substituents in the ortho position of cinnamate esters greatly accelerated conjugate addition reactions if they could chelate to lithium or copper (equation 319) [326]. Thiophenolcopper-Grignard reagent complexes were efficient in the 1,4-alkylation of conjugated esters (equation 320) [327].

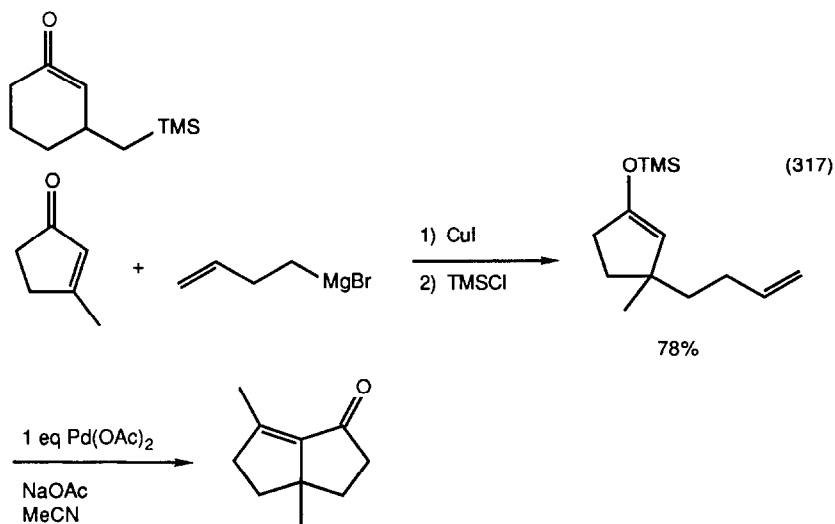
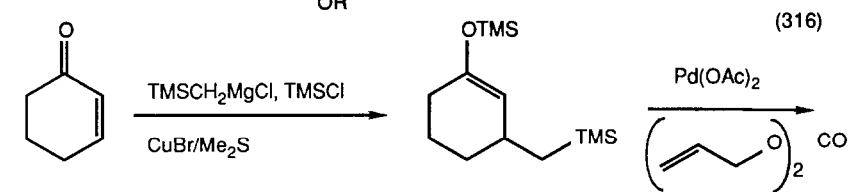
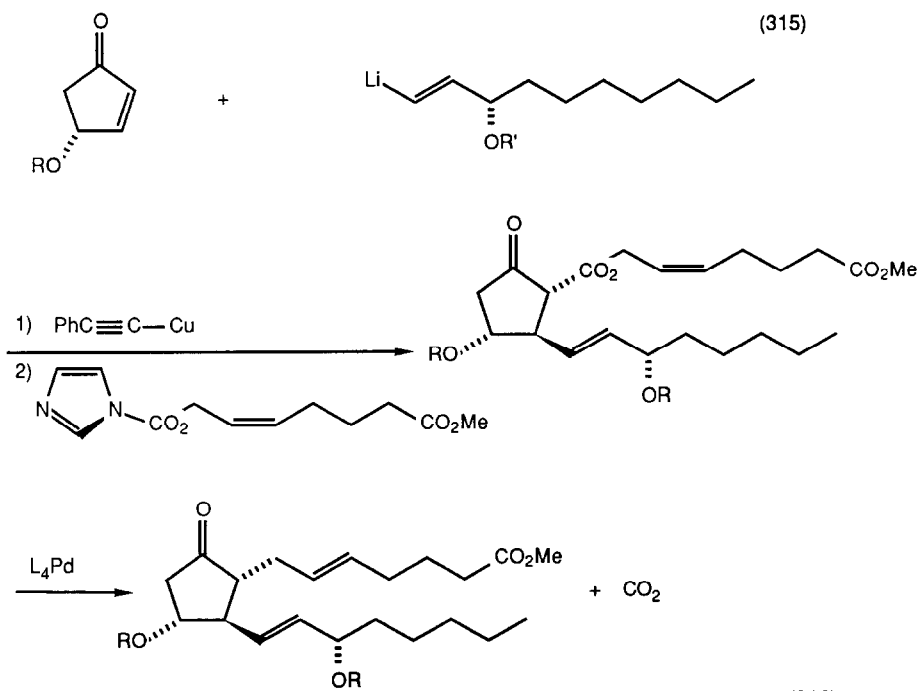

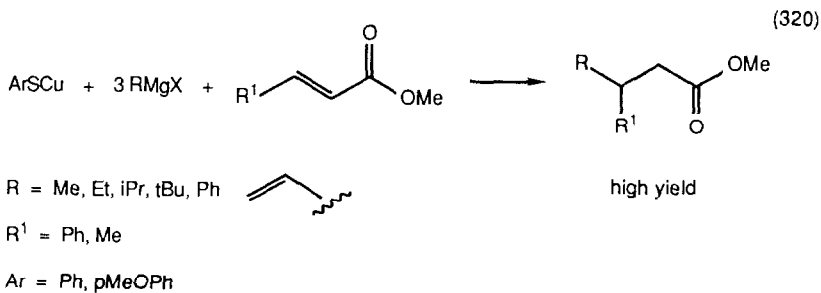
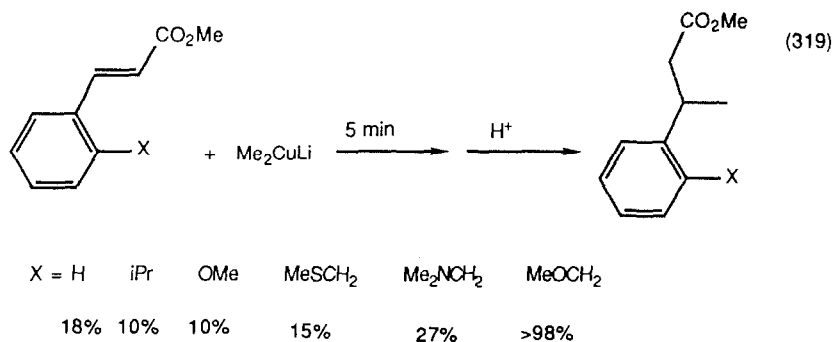
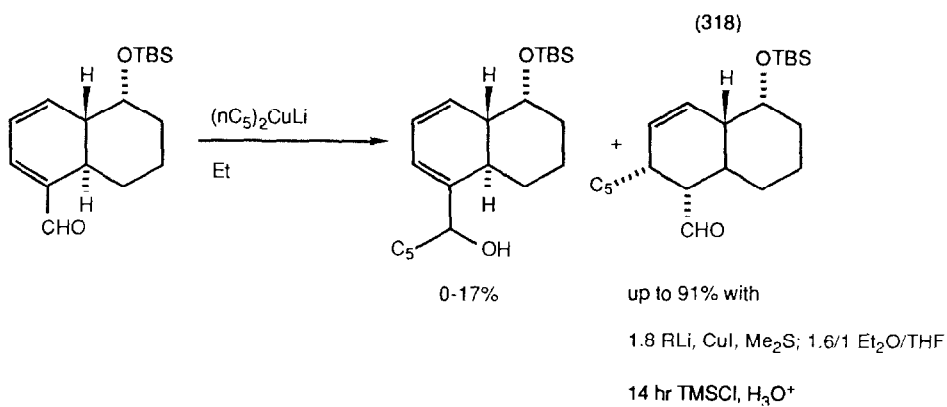

Trimethylsilyl chloride has been found to greatly accelerate conjugate alkylation of enones - particularly aldehydes - by cuprates both in catalytic (equation 321) [328a] and stoichiometric [328b] reactions (also equation 322) [329] and (equation 323) [330].



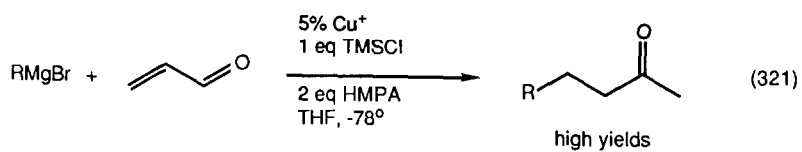

R = Ph, nPr, o-tol, nBu, nC<sub>6</sub>, Me

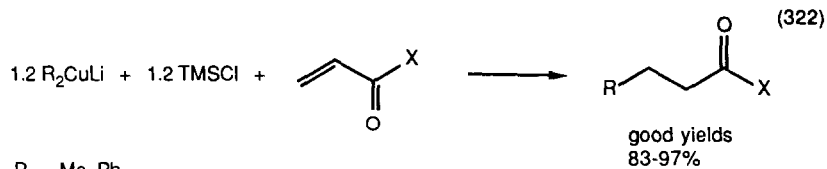
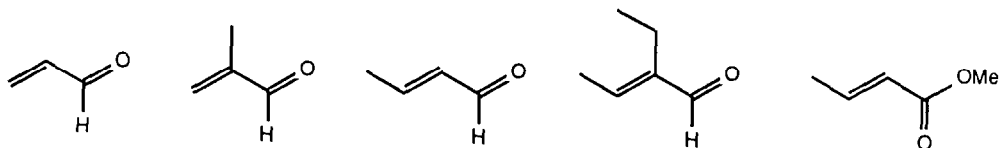
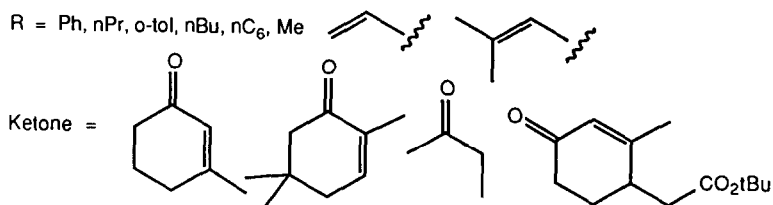

R = Me, Ph

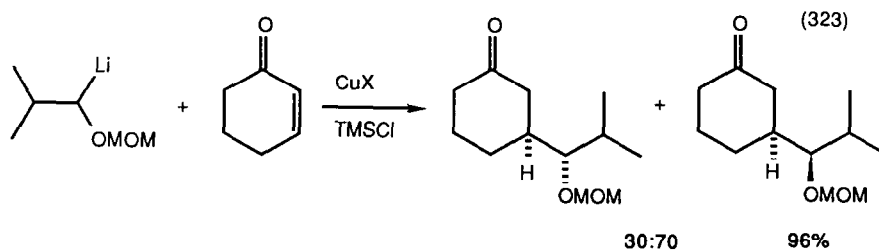
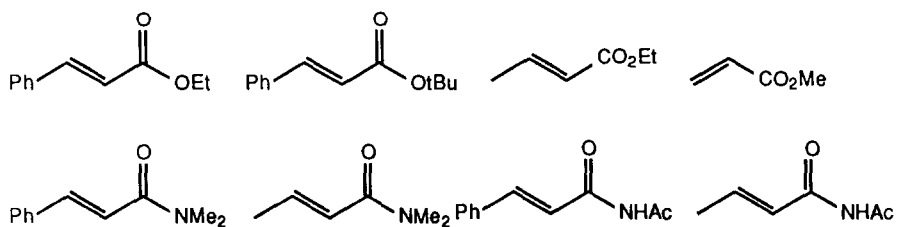

A number of approaches to induce chirality at the newly formed center in organocuprate conjugate alkylations have been developed. One involves conjugate addition to  $\alpha,\beta$ -unsaturated chiral heterocycles such as chiral cyclic aminals (equation 324) [331][332], (equation 325) [333] or proline amides (equation 326) [334]. Another involves conjugate addition to chiral sulfinimides (equation 327) [335][336]. Conjugated esters having chiral substituents at the  $\beta$ -position (equation 328) [337] and acrolein acetals of chiral 1,3-diols (equation 329) [338] also undergo conjugate alkylation with induction of asymmetry. Perhaps the most efficient approach involved conjugate alkylations of chiral conjugated menthol- or camphor bases esters (equation 330) [339] or sulfonamides (equation 331) [340], (equation 332) [341]. The use of chiral ligands on copper was somewhat less efficient (equation 333) [342] but worked well in some cases (equation 334) [343], (equation 335) [344].

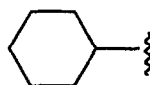
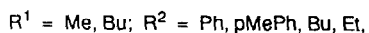
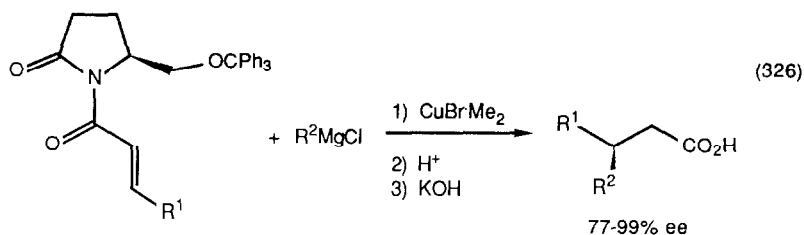
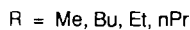
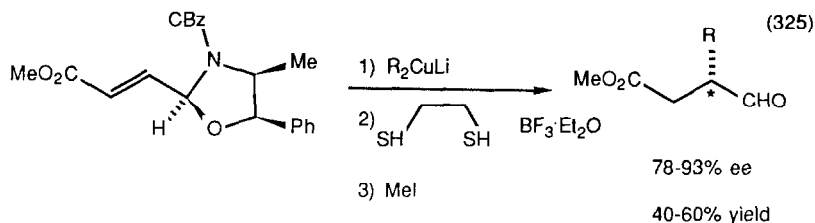
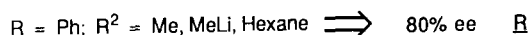
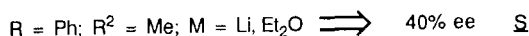
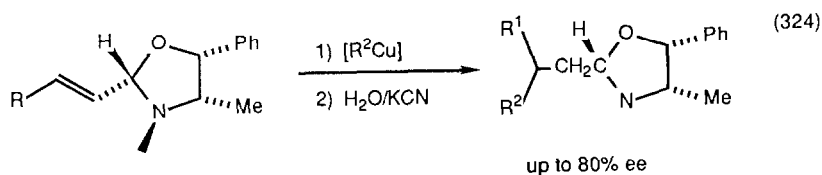

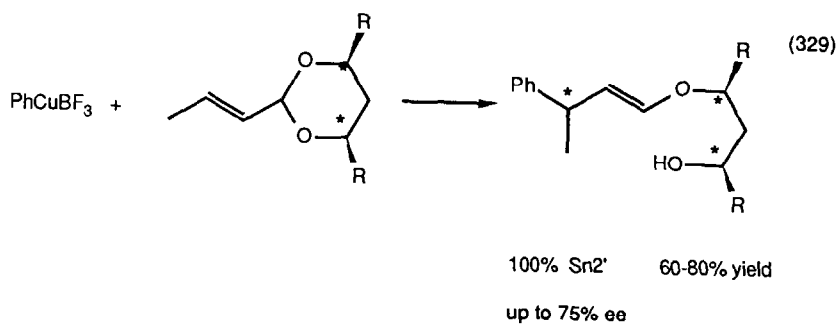
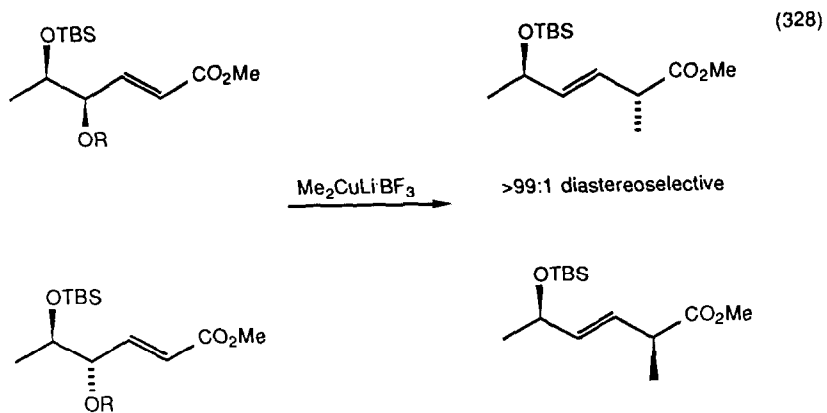
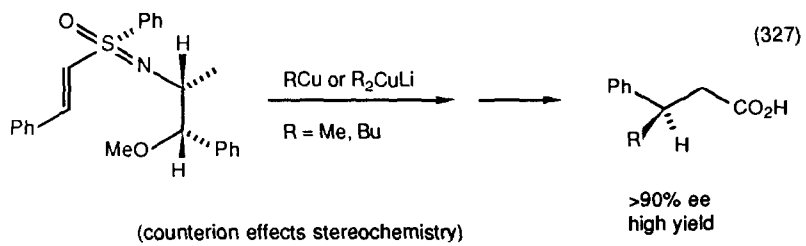

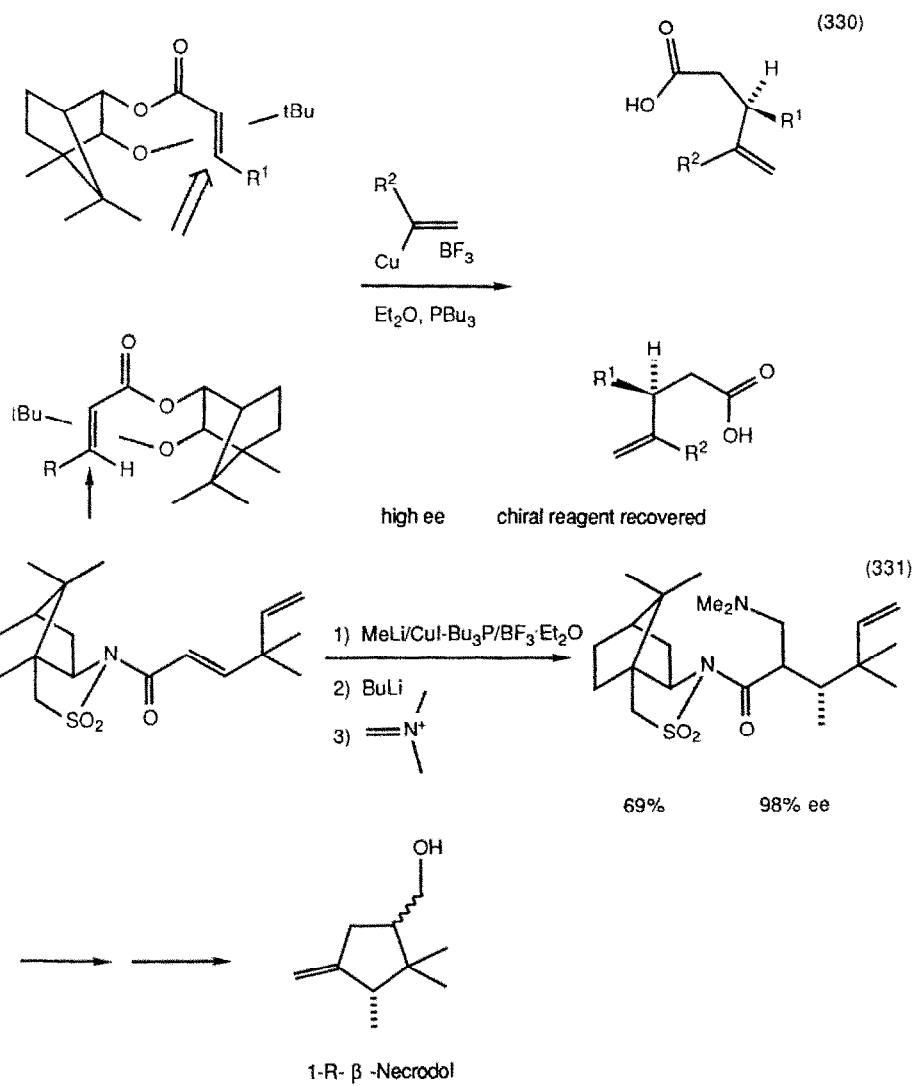

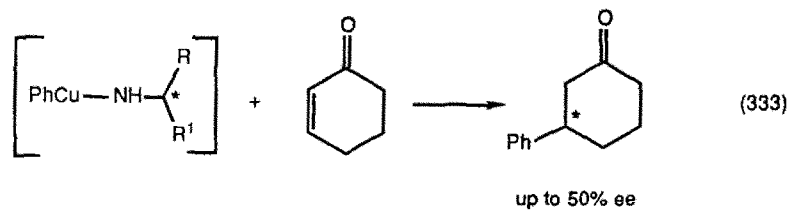
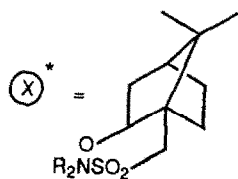
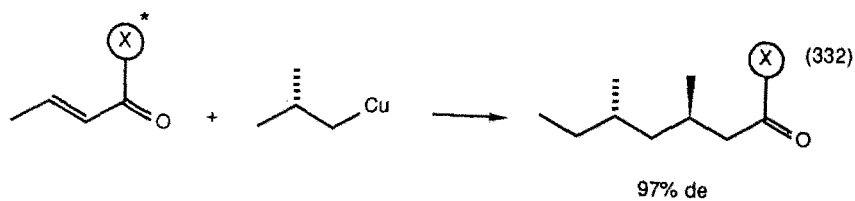

ee depends on amine, solvent, counterion, ligand, temperature

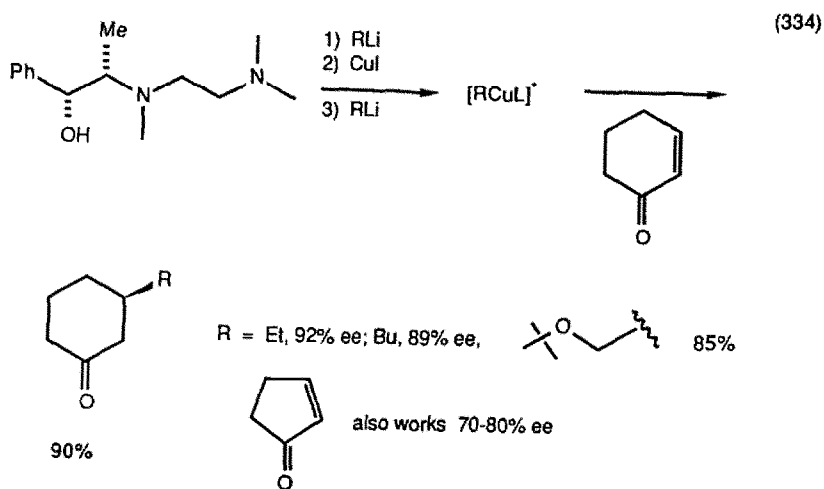

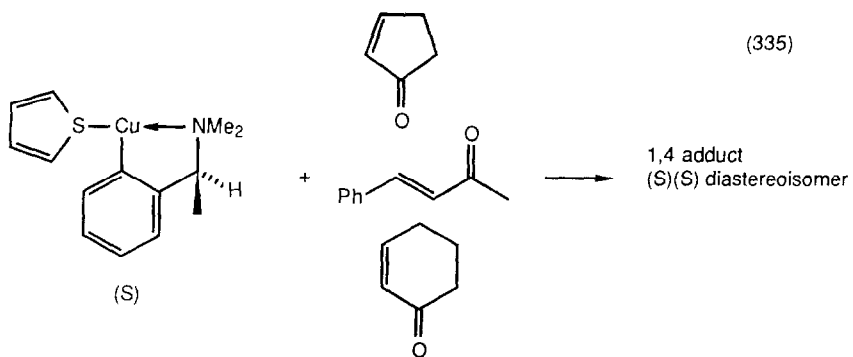

Organocuprates ring-opened quarternary cyclic imidates (equation 336) [345]. Conjugate additions to enones with leaving groups in the  $\beta$ -position resulted in both  $\alpha$ - (equation 337) [346], (equation 338) [347] and  $\beta$ -alkylation (equation 339) [348]. Remote groups controlled the stereochemistry of addition to cyclic vinyl sulfones (equation 340) [349], (equation 341) [350].

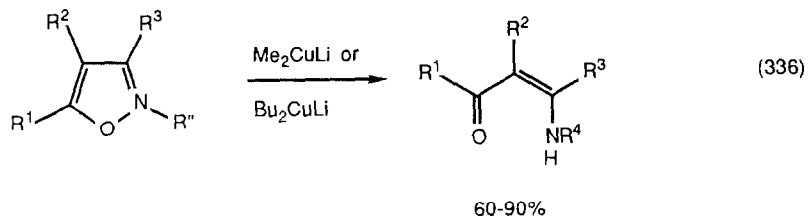

$R^1 = \text{Me, Ph}; R^2 = \text{H, Br, Cl, COPh, COMe, CO}_2\text{Et, CN, NO}_2$

$R^3 = \text{Me, Ph}; R^4 = \text{Me, Et}$

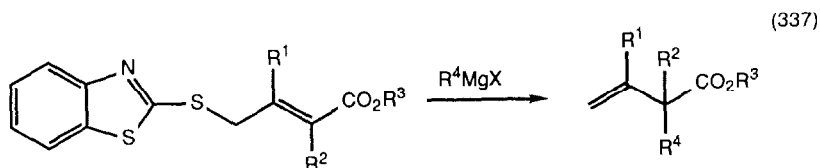

$R^1 = \text{H, Me}; R^2 = \text{H, Me}; R^3 = \text{Et}; R^4 = \text{nBu, nC}_8$

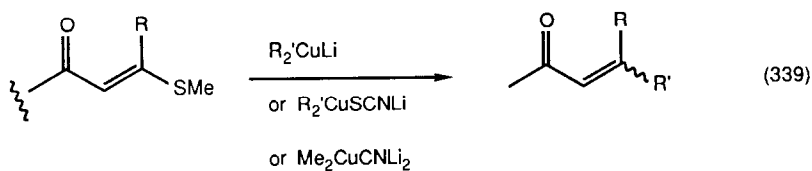
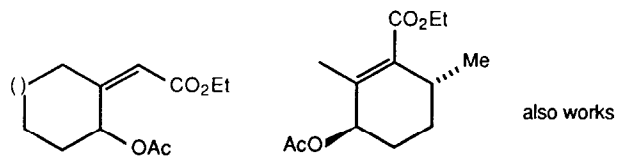
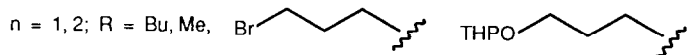
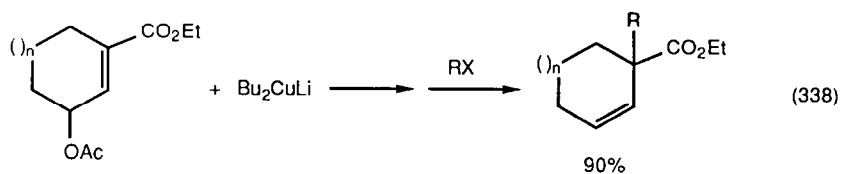

$R' = \text{Me, Bu, tBu, Pr, Ph, secBu}$

E  $\longrightarrow$  retention in THF  
inversion in  $\text{Et}_2\text{O}$

Z  $\longrightarrow$  retention in both

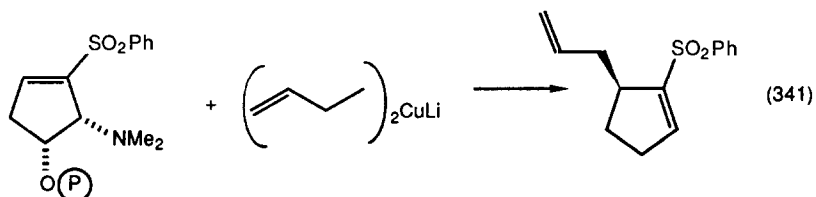
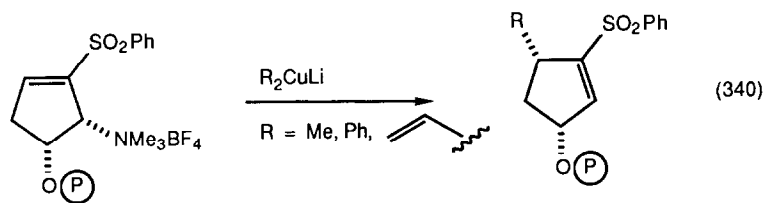

Methylcopper promoted the conjugate reduction of enones by DIBALH (equation 342) [351]. Palladium(O)/zinc mixtures catalyzed the same reduction with diphenylsilane as the reducing agent (equation 343) [352]. Ynones were reduced to enones by aqueous chormium(II) salts (equation 344) [353]. Iron-complexed 1,2-diazepines added to dimethyl acetylene dicarboxylate (equation 345) [354].

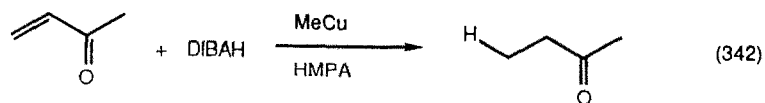

high yields

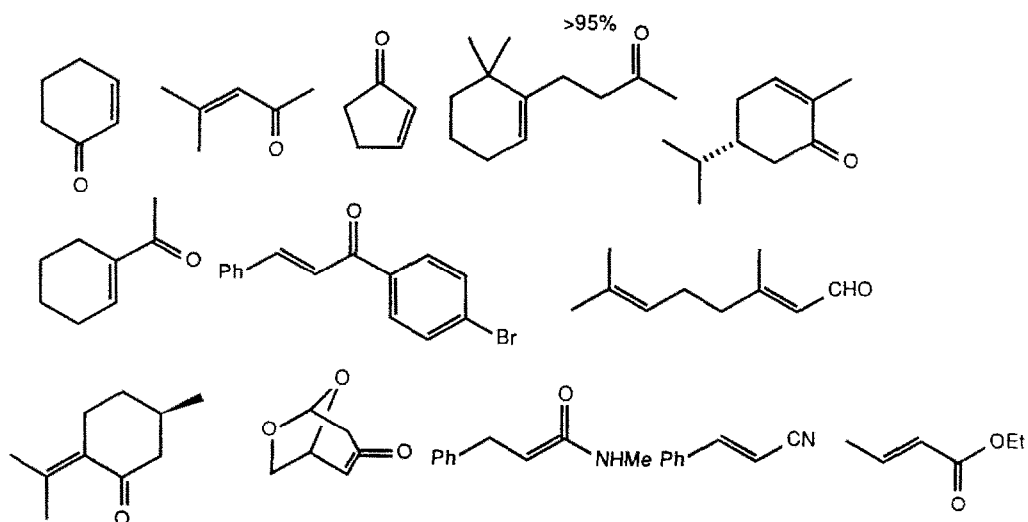
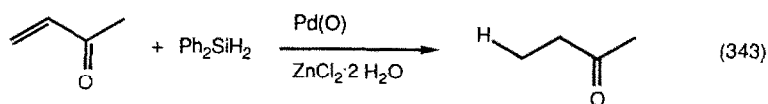
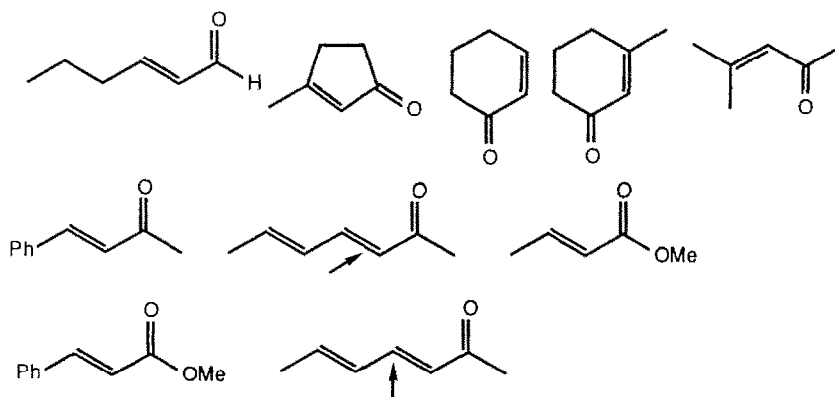



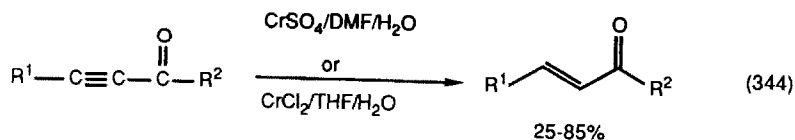

$\text{R}^1 = \text{tBu, Me, Et}$

$\text{R}^2 = \text{Me, Et, iPr, tBu, Ph}$

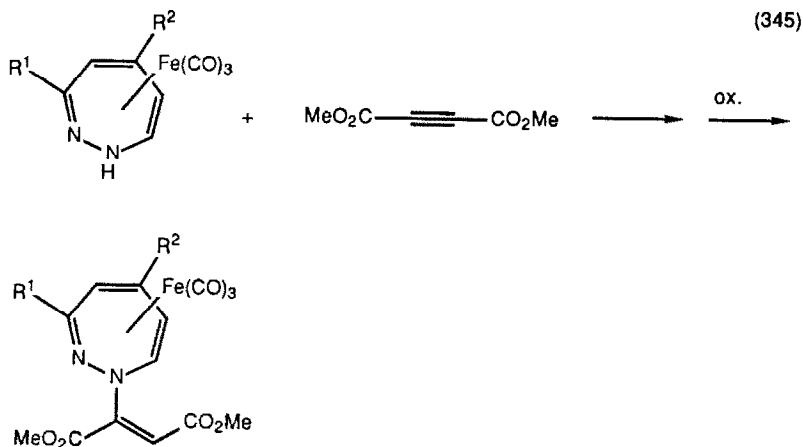

### C. Acylation Reactions (Excluding Hydroformylation)

#### 1. Carbonylation of Alkenes and Alkynes

"Transition metal catalyzed carbonylation reactions" was the subject of a review with no references [355]. "Transition metal in organic synthesis - hydroformylation, reduction and oxidation" annual survey for 1984 (631 references) has appeared [356]. "Metal carbonyls in phase transfer catalysis" has been reviewed (102 references) [357], as has homogeneous and phase-transfer catalyzed carbonylation reactions (27 references) [358].

Rhodium complex catalyzed olefin hydroformylation reactions have been reviewed (85 references) [359]. Tropane and piperidine carboxaldehyde were synthesized by the rhodium catalyzed hydroformylation of unsaturated nitrogen heterocycles [360]. Bimetallic cobalt-ruthenium catalyst systems were considerably more reactive in hydroformylation and hydroesterification reactions than was dicobalt octacarbonyl itself [361]. Platinum catalysts bound to chiral polymers effected asymmetric hydroformylation of styrene with 70-75% ee [362][363]. Adjacent ligands were used to direct olefin hydroformylation to a desired face of a molecule (equation 346) [364].

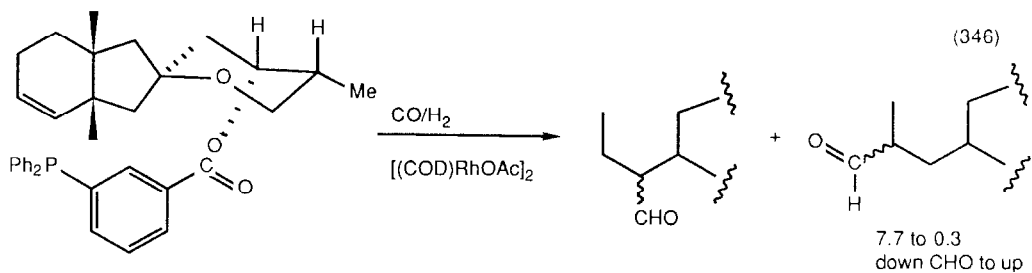

1:1

Hydrocarboxylation of unsaturated compounds has been reviewed [365]. The rate and selectivity of hydrocarboxylation of  $\alpha$ -olefins with a  $\text{PdCl}_2(\text{PPh}_3)_2$  catalyst increased in the order  $\text{C}_3 < \text{C}_5 < \text{C}_7, \text{C}_9$  [366]. The effects of reaction conditions on the  $\text{PdCl}_2(\text{PPh}_3)_2$  catalyzed hydrocarboxylation of ethyl 3-butenolate [367] and 1-heptene [368] were studied. The hydrocarboxylation of styrene over  $\text{PdCl}_2(\text{PPh}_3)_2$  catalysts was more efficient in a CO atmosphere than in an atmosphere of synthesis gas [369]. Palladium chloride catalyzed the oxidative carbonylation of conjugated dienes (equation 347) [370].

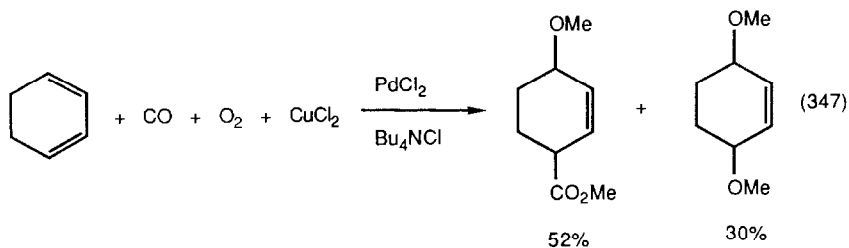

Cobalt complexes (equation 348) [371], rhodium complexes (equation 349) [372] and palladium complexes (equation 350) [373] catalyzed intramolecular acylation processes.

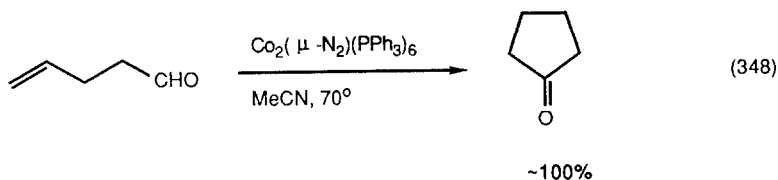

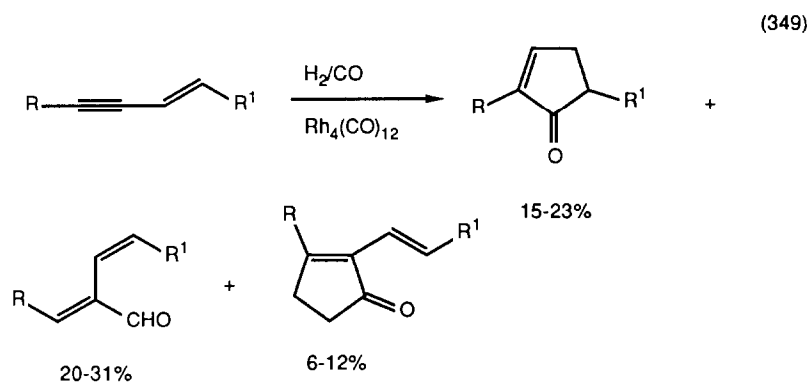

R = Ph, pMeOPh, pCNPh

R<sup>1</sup> = Ph

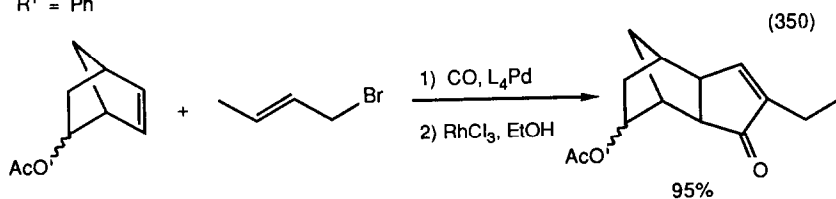

Coordinated pyridine underwent bis-orthocyclization when butalized (equation 351) [374]. Titanacyclobutenes inserted CO to give metal-bound vinylketenes (equation 352) [375]. Cationic iron carbene complexes inserted CO, and were oxidatively cleaved to malonates (equation 353) [376].

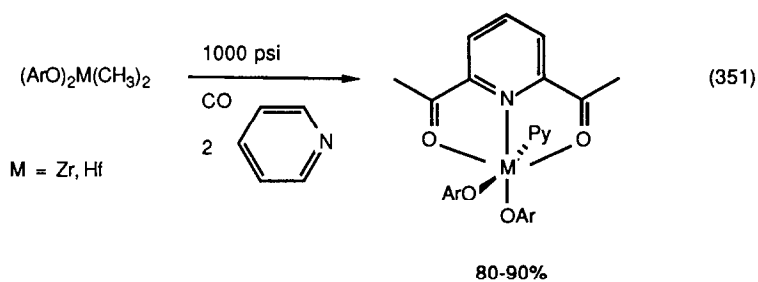

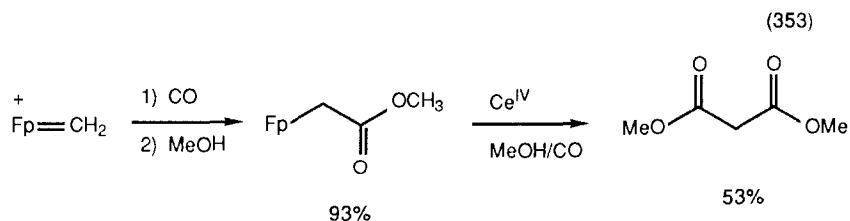
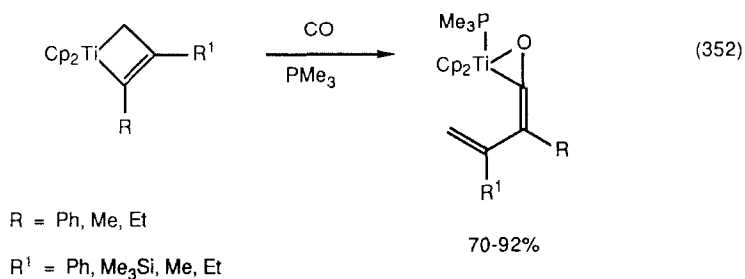

Cyclohexadiene iron complexes underwent carbonylation in the presence of Lewis acids to give bridged bicyclic ketones (equation 354) [377]. Butadiene iron tricarbonyl complexes (equation 355) [378] and cycloheptatrieneiron carbonyl complexes (equation 356) [379] underwent acylation and further useful transformation. Phenylacetylene was carbonylated to methyl cinnamate and methyl atropate  $\text{RhCl}(\text{CO})(\text{PPh}_3)_2$  catalysts [380].

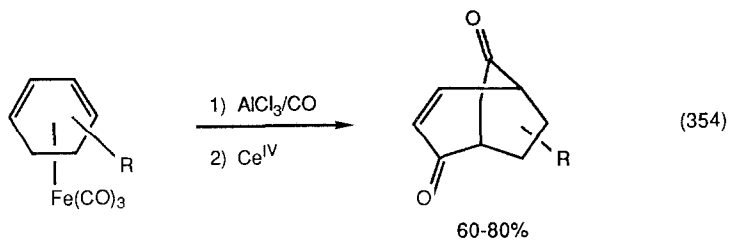

(R's = methyls everywhere)

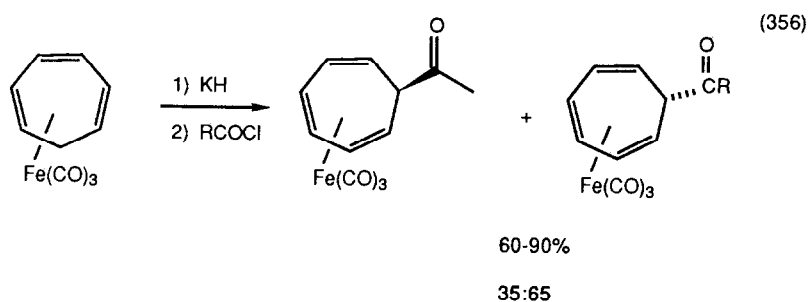
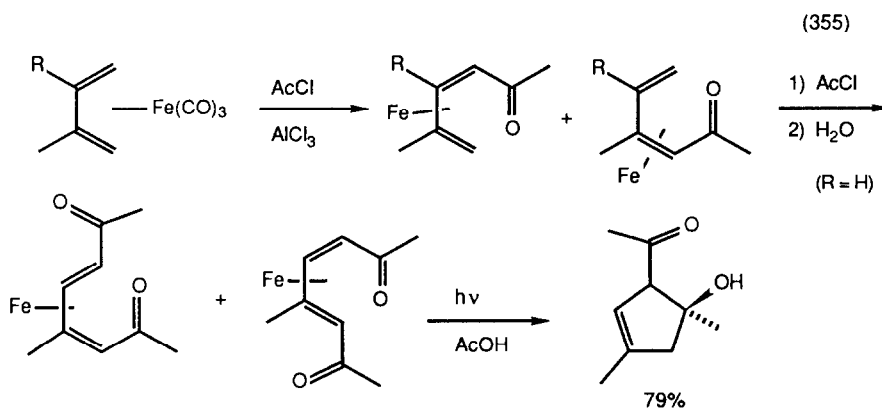

## 2. Carbonylation of Halides

"Palladium-catalyzed carbonylation reactions of organic halides with tributyltin hydride" was the subject of a dissertation [381]. Palladium catalyzed the efficient conversion of aryl iodides (equation 357) and vinyl iodides (equation 358) to aldehydes in high yield [382]. Platinum(II) complexes catalyzed the conversion of aliphatic iodides to aldehydes (equation 359) [383].

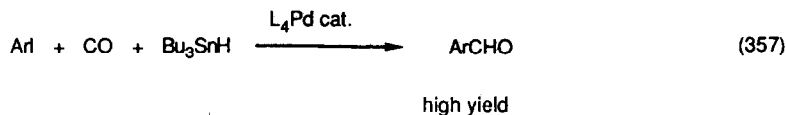

Ar = Ph, pBrPh, mClPh, pCHOPh, pMeO<sub>2</sub>CPh, mMeO<sub>2</sub>CPh, oMeO<sub>2</sub>CPh, pCF<sub>3</sub>Ph  
pMePh, oMePh, pMeOPh, oHOCH<sub>2</sub>Ph, oTHPOCH<sub>2</sub>Ph

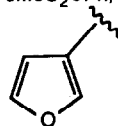

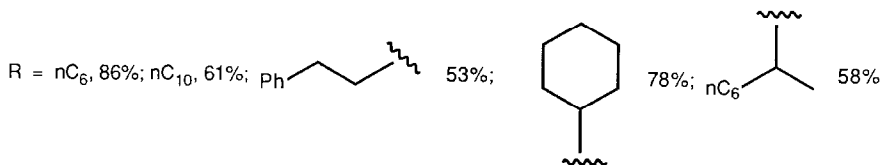
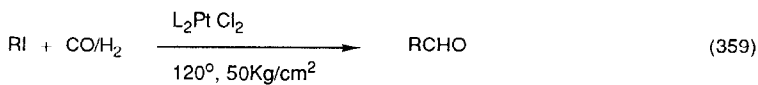
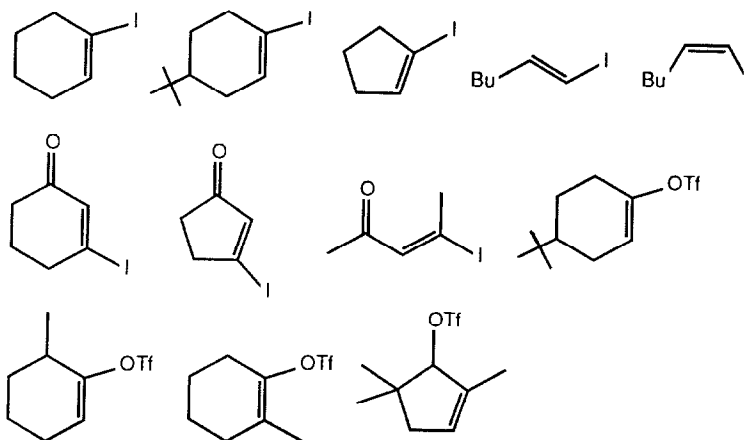
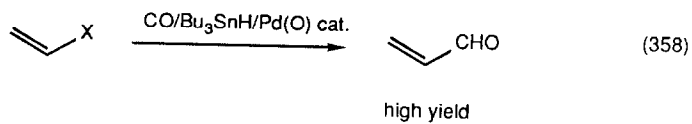

Iron pentacarbonyl catalyzed the carbonylation of benzyl halides to phenylacetic acids under phase transfer conditions [384]. A similar system could be adjusted to produce ketones instead of acids (equation 360) [385]. Cobalt octacarbonyl carbonylated aryl halides under phase-transfer conditions (equation 361) [386]. Polyhaloaromatics were converted to polycarboxylic acids by cobalt octacarbonyl acid aqueous base under irradiation (equation 362) [387][388].

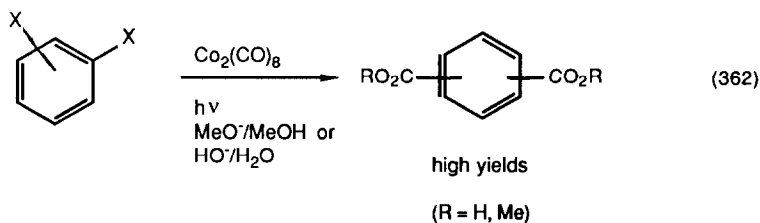
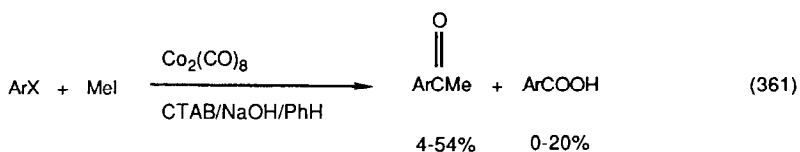
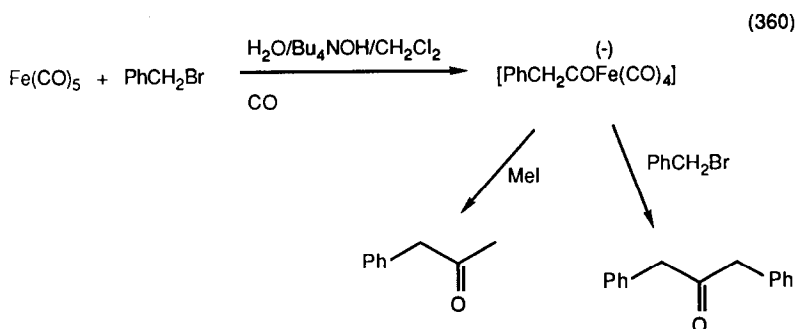

Aryl iodides were converted to  $\alpha$ -ketoesters by palladium-catalyzed double carbonylation [389]. Alkyl halides underwent a similar double carbonylation in the presence of cobalt carbonyl catalysts [390]. Under basic conditions cobalt carbonyl catalyzed the double acylation of aryl (equation 363) and benzyl halides (equation 364) [391]. The palladium catalyzed double carbonylation of *o*-iodoacetanilide was used to prepare quinolines and indolones (equation 365) [392].

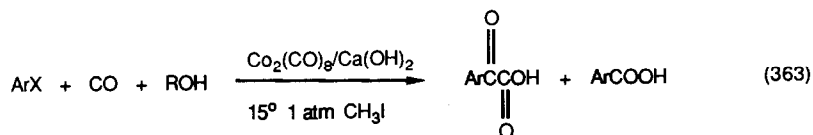

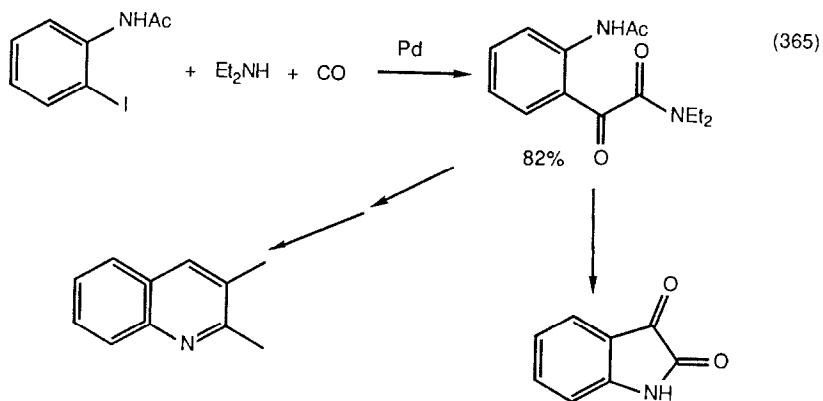
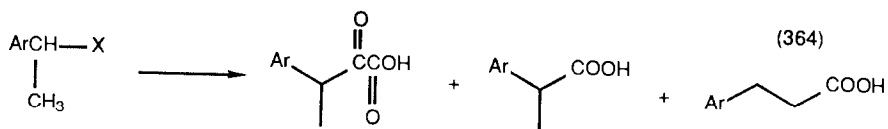

The rate determining step in palladium catalyzed carbonylations of organic halides was shown to be cleavage of a palladium acyl complex by alcohol, not reductive elimination of acyl-alkoxide (equation 366) [393]. N-Tosylenamines were iodinated and then carbonylated under palladium catalysis (equation 367) [394]. Palladium also catalyzed an intramolecular acylation (equation 368) [395], as well as the combination of aryl halides, carbon monoxide and stabilized carbanions (equation 369) [396].

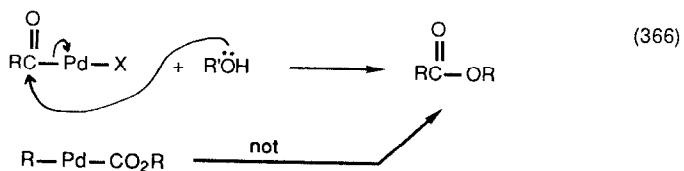



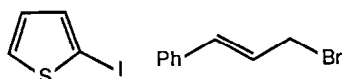
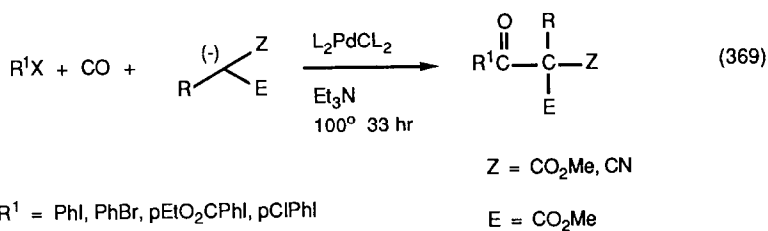
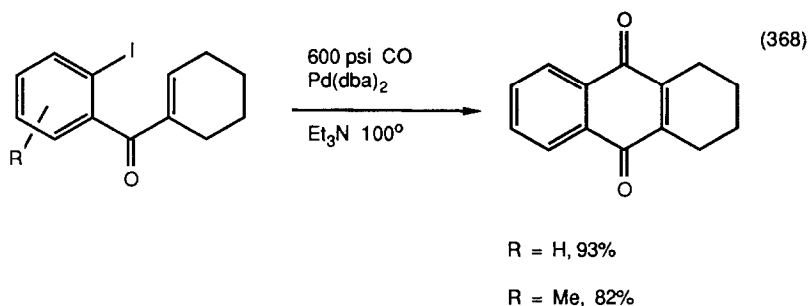
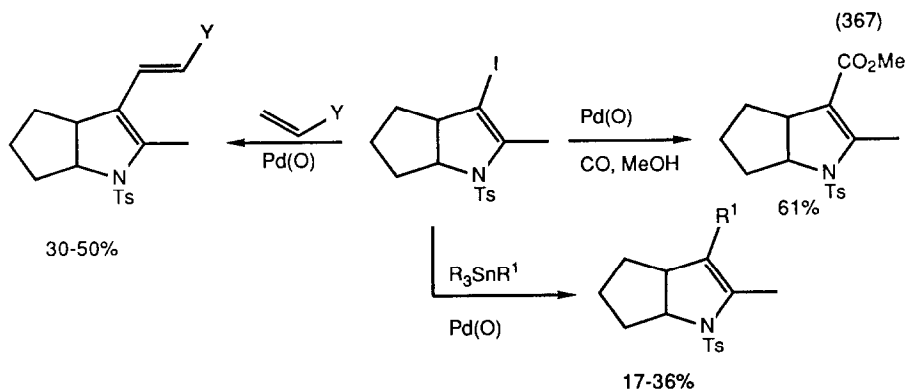

Aryl and benzyl halides were converted to ketones by reaction with CO and alkyl boranes in the presence of reduced palladium catalysts (equation 370) [397]. Iodobenzene and phenyl acetylene combined to give the phenyl-alkynyl ketone when treated with a palladium catalyst under 20 atmospheres of CO at 120° [398]. Trimethylsilylbutadiene iron complexes underwent acylation by acid halides (equation 371) [399]. Geminal dibromocyclopropanes were carbonylated by nickel carbonyl

(equations 372 and 373) [400]. Geminal dihalides were reductively carbonylated to esters or amides in the presence of metallic zinc and transition metal catalysts (equation 374) [401]. Aryl triflates were carbonylated over Pd catalysts (equation 375) [402].

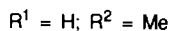
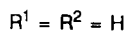
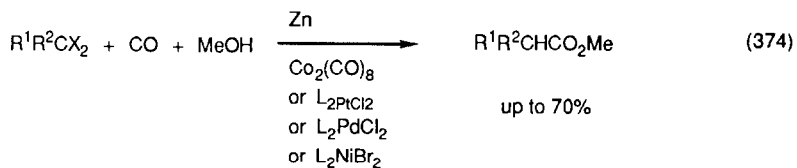
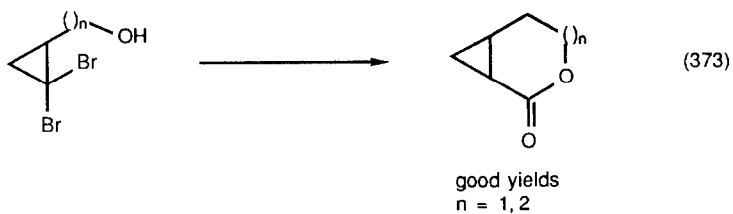
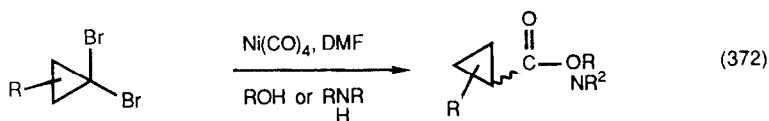
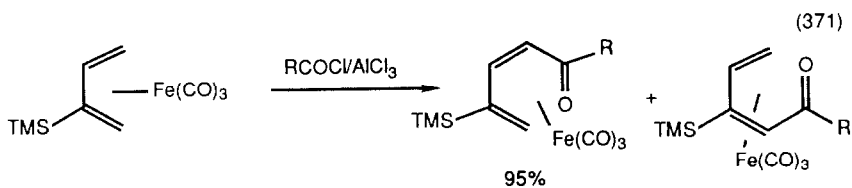
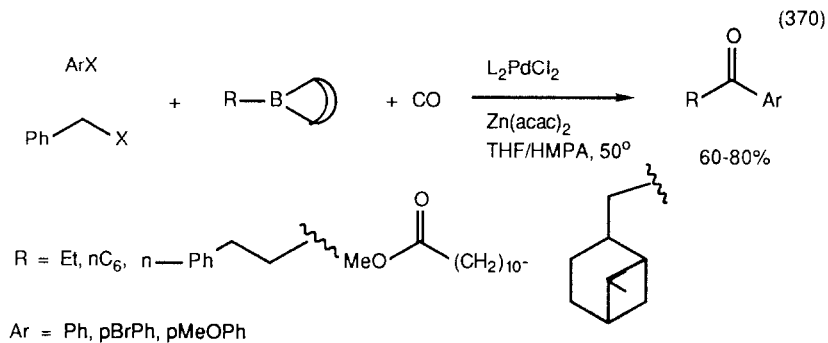

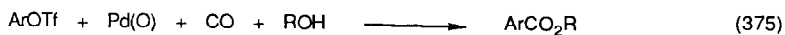

### 3. Carbonylation of Nitrogen Compounds.

Amines were efficiently N-formylated over ruthenium carbonyl cluster catalysts (equation 376) [403]. The same system aminocarbonylated olefins (equation 377). Thirty five promoters for the palladium catalyzed carbonylation of nitro and azobenzene were examined [404]. A wide variety of palladium and vanadium catalysts were screened for activity in the carbonylation of nitromesitylene [405]. Carbonylation of nitromesitylene to the isocyanate was catalyzed by  $\text{Rh}_2\text{Cl}_2(\text{CO})_4$  and  $\text{MoOCl}_3$  [406]. Imines were acylated by carbon monoxide in the presence of thiols by cobalt octacarbonyl (equation 378) [407]. Mixed rhodium/cobalt catalyst systems catalyzed the amidocarbonylation of substituted allylic alcohols (equation 379) [408].  $\beta$ -Aminoacyl complexes of palladium were aminoacylated (equation 380) [409].

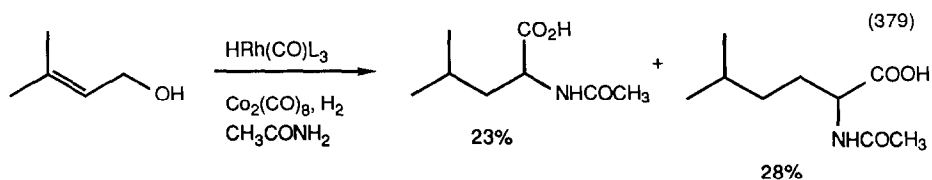
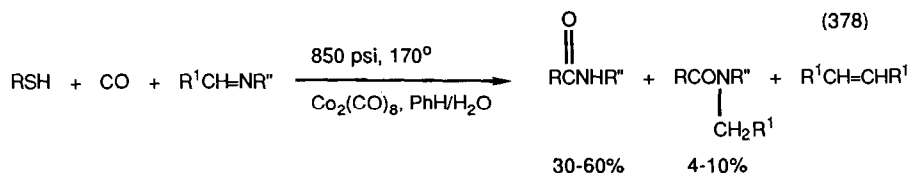
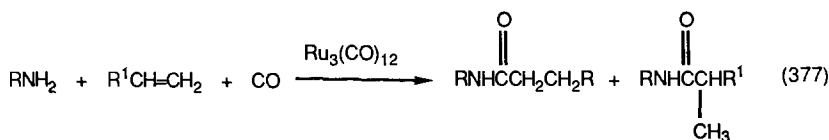
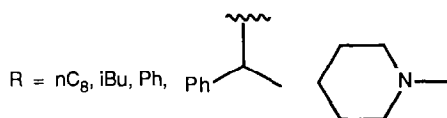
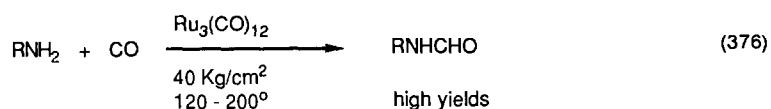

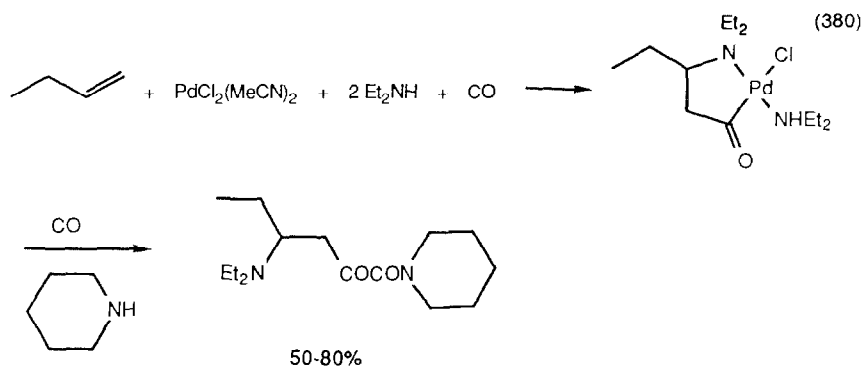

#### 4. Carbonylation of Oxygen Compounds

Methanol was hydroformylated to 1,1-dimethoxyethane by iodine-promoted cobalt catalysts [410]. Primary alcohols were carbonylated to esters over ruthenium, rhodium or cobalt catalysts [411]. The full details of the useful carbonylative homologation of secondary acetates have been published (equation 381) [412].

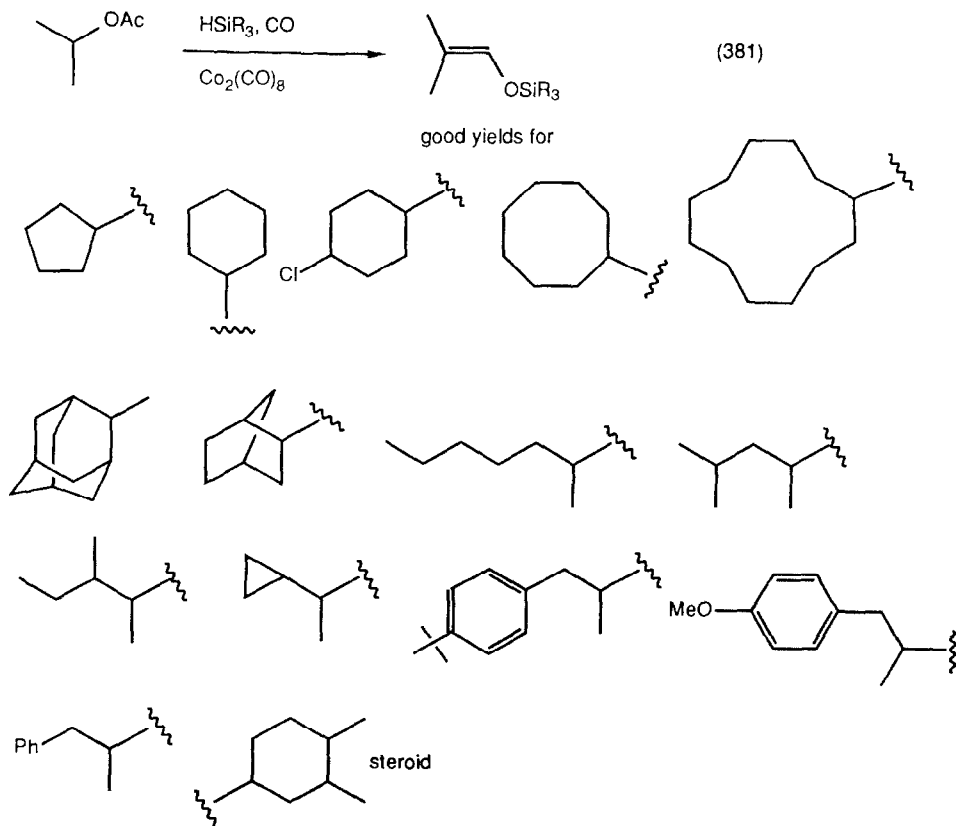

### 5. Miscellaneous Carbonylations

Thiophenes, furans and pyrroles were carbonylated in the 2-position using palladium catalysts (equation 382) [413]. Methyl acetate was homologated to ethyl acetate over  $\text{Ru}(\text{CO})_3\text{I}_3^-$  catalysts [414]. Dimethylether was reductively carbonylated to acetaldehyde and ethanol over cobalt catalysts [415]. Olefin homologation was compared with Fischer-Tropsch syntheses in regards to the mechanism of carbon-carbon bond formation [416].

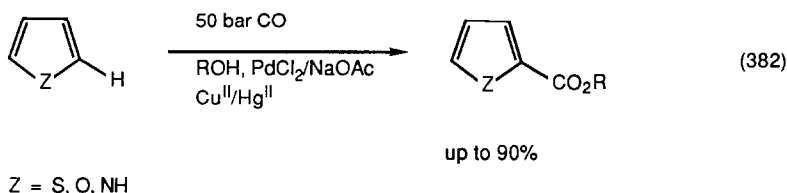

### 6. Decarbonylation Reactions

Conditions to extend the lifetime of palladium catalysts for the decarbonylation of furfural have been developed [417]. Bridgehead acid chlorides decarbonylated to give rearranged, nonbridgehead olefins (equation 383) [418]. Aroyl cyanides were decarbonylated to aromatic nitriles by palladium catalysts, while aliphatic systems gave olefins (equation 384) [419].

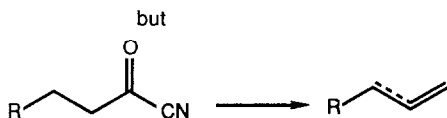
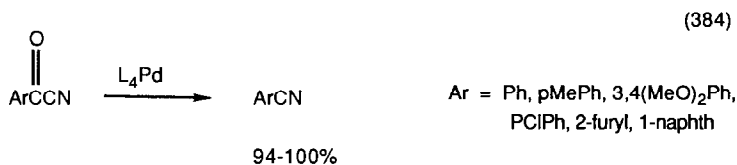
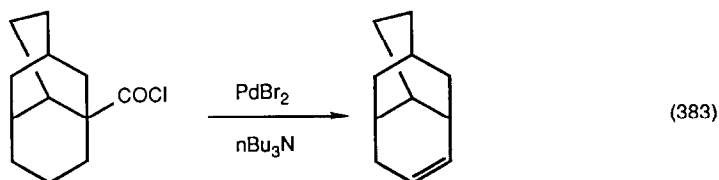

## 7. Reactions of Carbon Dioxide

The synthesis of organic chemicals by catalytic reactions of carbon dioxide has been reviewed (16 references) [420]. Aryl and vinyl halides, as well as allyl acetates were reductively carboxylated by carbon dioxide in the presence of palladium(O) catalysts (equation 385) [421]. Diethyl amine was converted to tetraethyl urea, and diethyl formamide by carbon dioxide and palladium(II) catalysts (equation 386) [422]. Aryl halides were carboxylated under photolytic conditions by dicobalt octacarbonyl [423]. Propargyl alcohols were converted to carbonates by reaction with carbon dioxide and ruthenium catalysts (equation 387) [424]. Terminal alkynes were converted to enol carbamates by reactions with carbon dioxide, secondary amines and ruthenium catalysts (equation 388) [425][426].

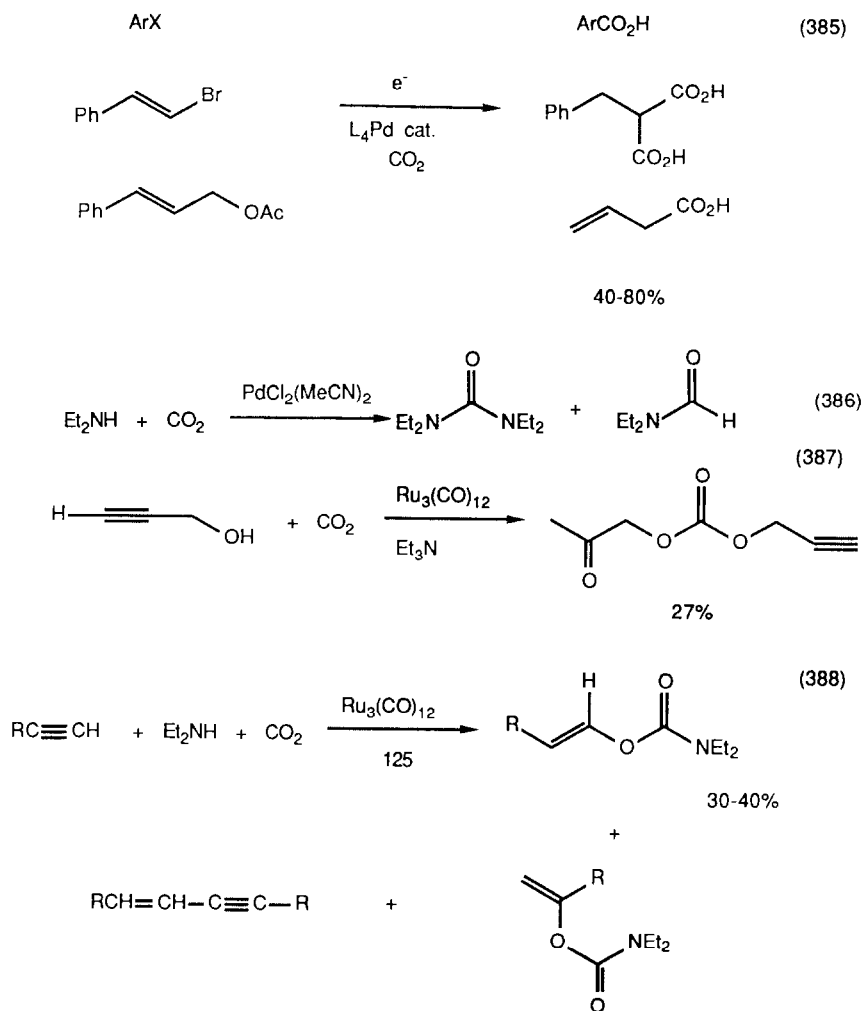

Nickel(O) complexes catalyzed the carboxylation of quadricyclene (equation 389) [427], styrene (equation 390) [428], ethylene (equation 391) [429] and benzocyclopropane (equation 392) [430]. Nickelacyclopentanes readily inserted carbon dioxide (equation 393) [431]. Bis-cyclooctadiene nickel effected the bis carboxylation dienes (equation 394) [432] as well as the telomerization-carboxylation of butadiene (equation 395) [433]. Butadieneiron tris-phosphine complexes also incorporated carbon dioxide into their ligand framework (equation 396) [434].

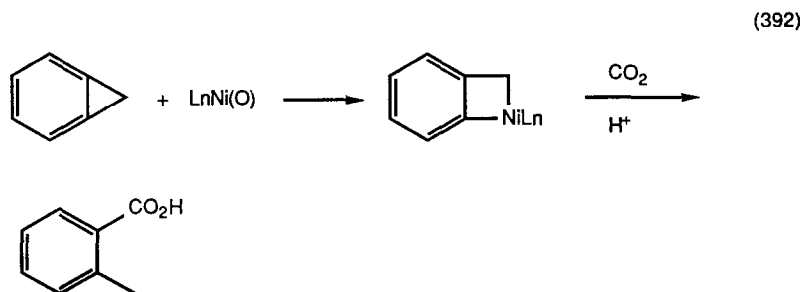
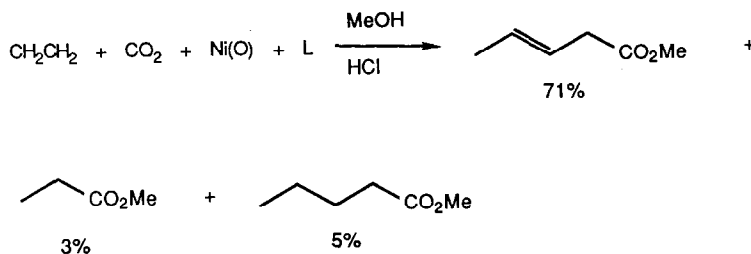
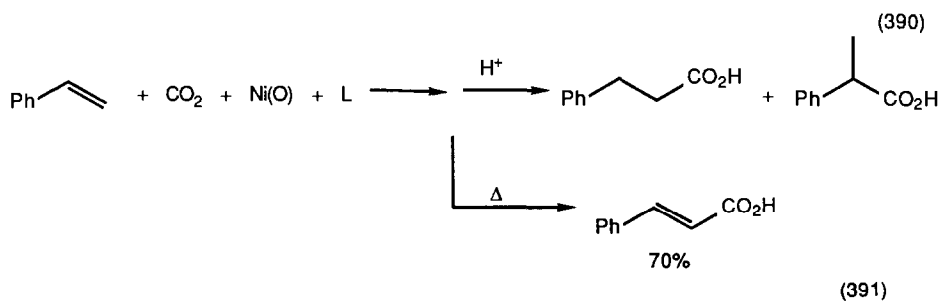
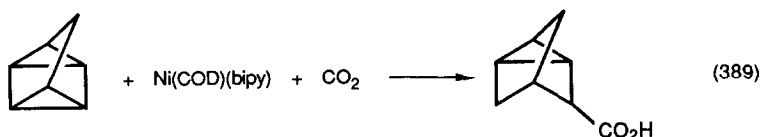

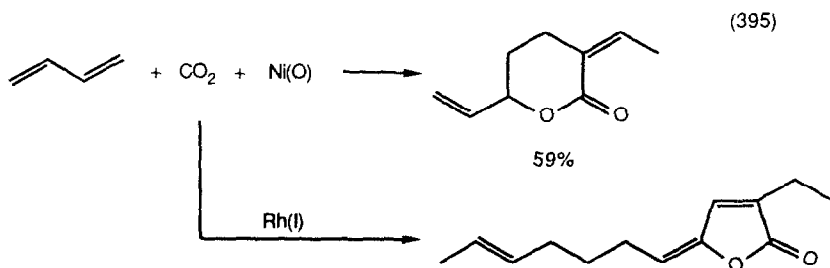
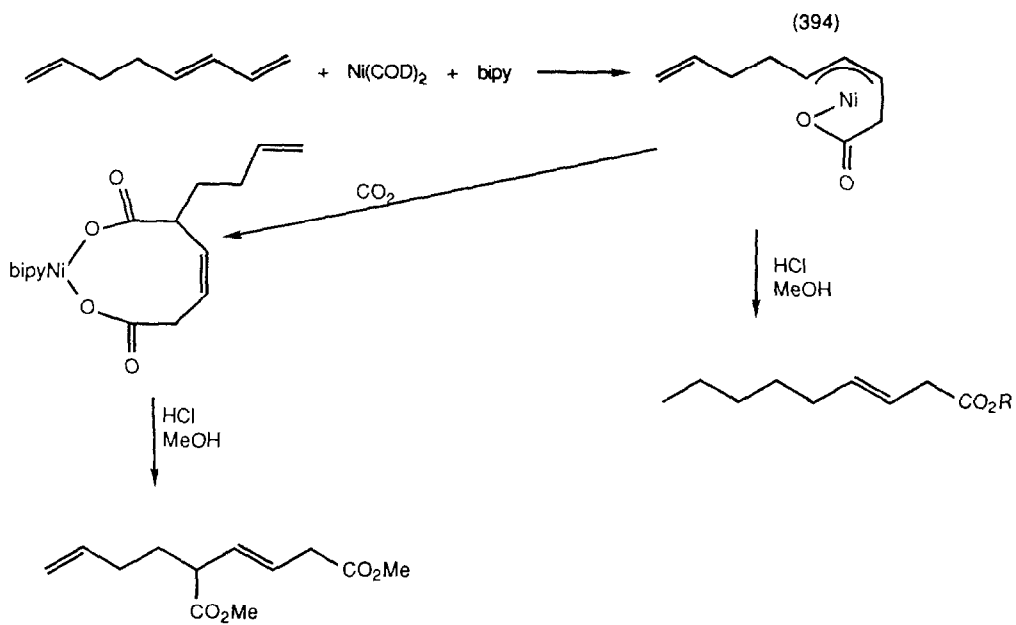
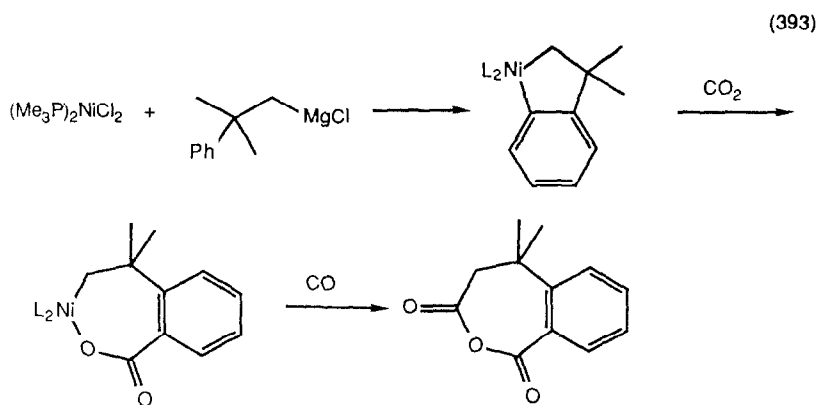



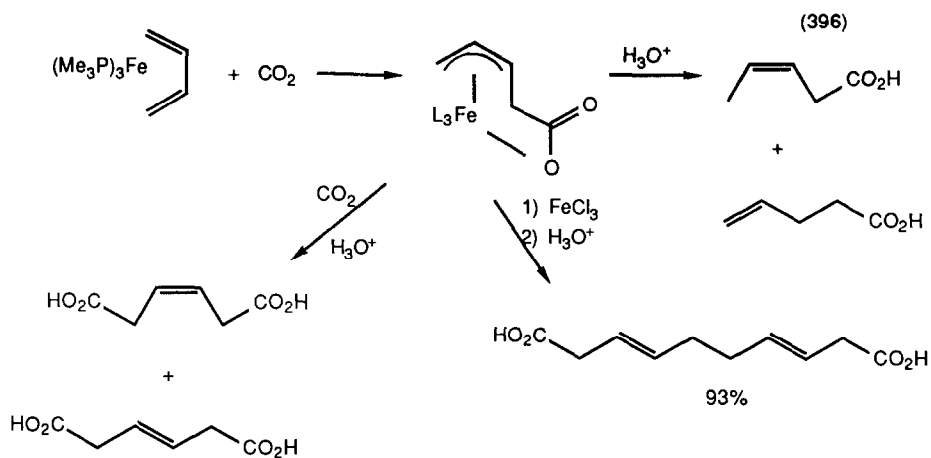

Propargyl carbonates were decarboxylated to allenes by low valent palladium complexes (equation 397) [435].  $\alpha$ -Cyano allyl esters were converted to unsaturated nitriles by palladium(O) catalysts (equation 398) [436].

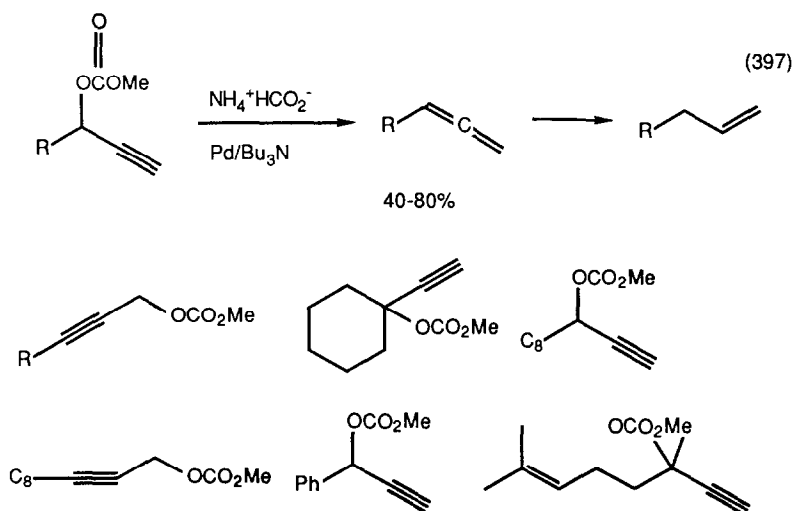

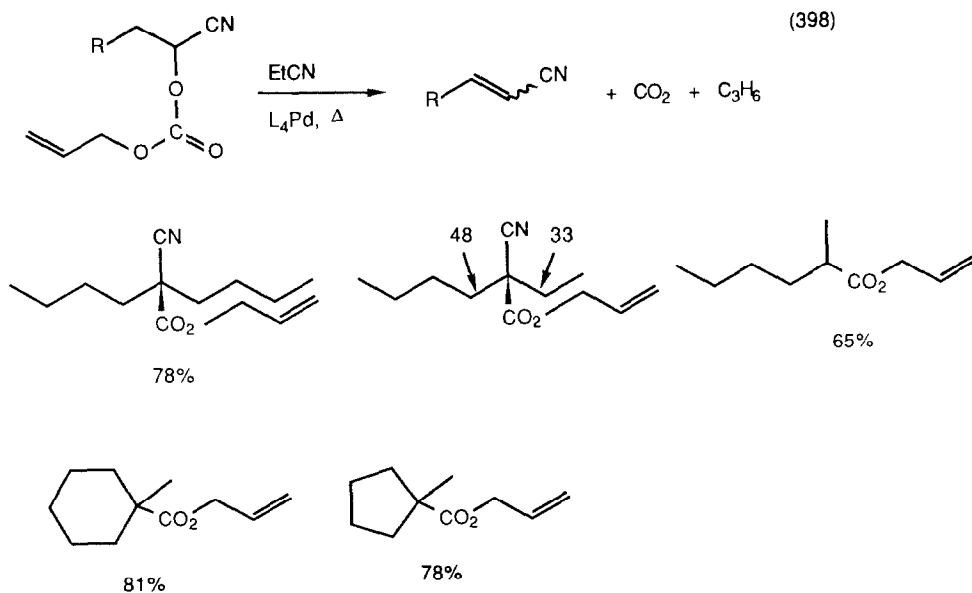

#### D. Oligomerizations

"Dimerization of ethylene and propylene catalyzed by transition metal complexes" was the title of a review (567 references) [437]. Ethylene was polymerized by  $[\text{Cp}_2\text{ZrCH}_3\text{CTHF}]+\text{BPh}_4$  [438]. Ethylene was dimerized to 1-butene by titanium alkoxide/alkyl aluminum catalysts [439]. Nickel-oxide, titanium/sulfate ion systems catalyzed ethylene dimerization [440]. Cationic  $\eta^3$ -allylnickel complexes dimerized and trimerized ethylene [441]. Gel immobilized nickel catalyst system dimerized lower olefins [442].  $\eta^3$ -Cyclooctenyl nickel perfluoroacetylacetonate catalyzed the linear dimerization of propene and 1-butene [443]. Nitroxyl radicals were used to reduce the formation of polyethylene in ethylene oligomerization over titanium(IV) chloride-dichloroethylaluminum catalysts [444]. Propene underwent linear oligomerization over diethylaluminum ethoxide/nickel hexafluoroacetylacetonate catalyst [445].

Ziegler-Natta type catalysts promoted the codimerization of styrene and propylene [446]. Nickel(O) complexes catalyzed the cooligomerization of methyl acrylate with dimethylcyclopropene (equation 399) [447]. Rhodium catalyzed the cooligomerization of 1,3-diene with 3-butenic acid (equation 400) [448].

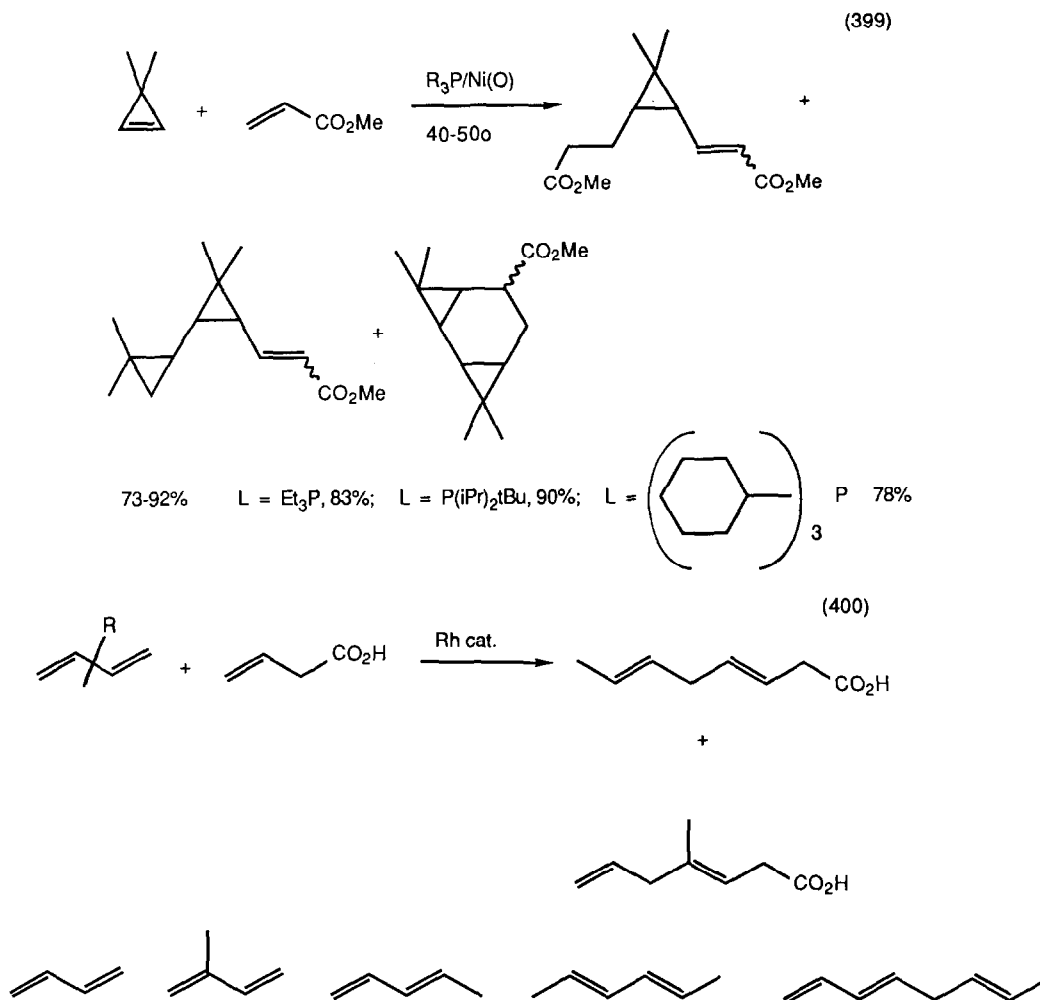

Rh(diphos)( $\eta^6\text{-BPh}_4$ ) catalyzed the head to tail coupling of allene [449]. Butadiene was linearly dimerized gel-immobilized iron complex catalyst [450]. Polyethylene bound nickel(O) catalysts gave the same reactivity and selectivity as homogeneous catalysts in the cyclooligomerization of butadiene but could be easily recovered and reused [451]. Palladium(II) acetylacetonate catalyzed the telomerization of butadiene and water [452], and isoprene with water [453]. A PdCl<sub>2</sub>/VOCl<sub>2</sub>/FeCl<sub>3</sub> catalyst converted butadiene to octyl alcohol [454].  $\eta^3$ -Allylpalladium catalysts promoted the telomerization of butadiene and isoprene with cyclohexenone (equation 401) [455]. The intermediates in the bis- $\eta^3$ -allylpalladium catalyzed oligomerization and telomerization of butadiene have been characterized (equation 402) [456]. The

telomerization of butadiene, carbon monoxide, and ethylene oxide was catalyzed by palladium complexes (equation 403) [457].

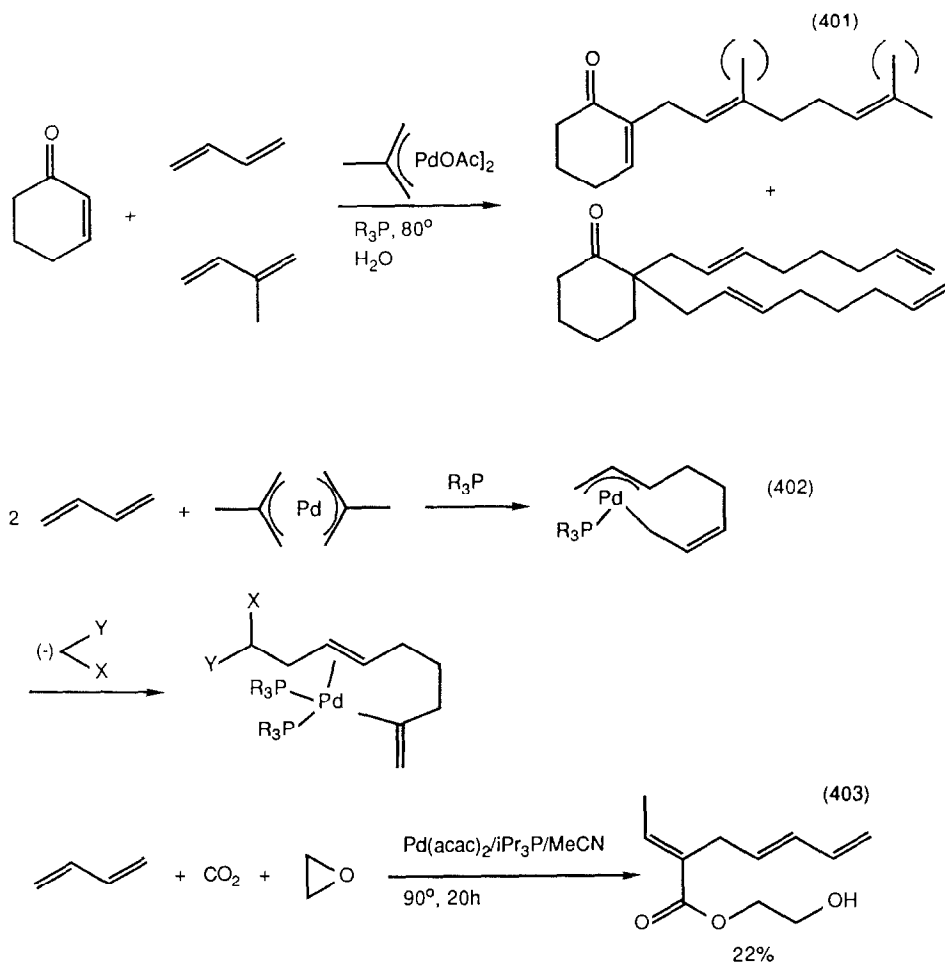

Alkyne oligomerization has been reviewed (116 references) [458]. Bis-trimethylsilylacetylene was dimerized to tetrakis-trimethylsilyllallene in very low yield by  $\text{CpCo}(\text{CO})_2$  (equation 404) [459]. Terminal alkynes were dimerized to 1,3-dienes by reduced cobalt species (equation 405) [460]. Acetylene was alkylated and homologated via organocopper chemistry (equation 406) [461]. Alkyltitanium complexes catalyzed the cooligomerization of bis-trimethylsilylacetylene and norbornadiene (equation 407) [462].  $\eta^6$ -Bis benzene chromium catalyzed the cooligomerization of perfluoropropene with perfluorobut-2-yne (equation 408) [463].

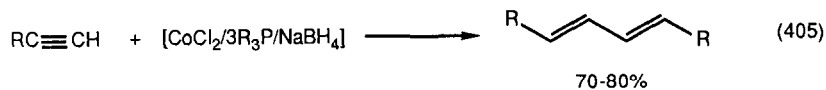
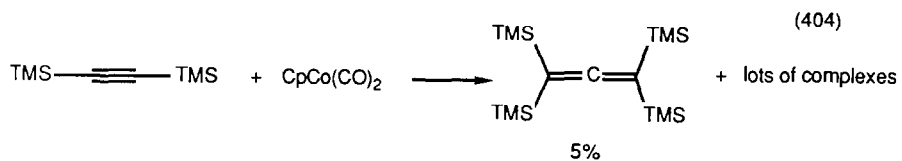

R = nC<sub>8</sub>, nC<sub>6</sub>, nC<sub>5</sub>, Ph, MeO<sub>2</sub>C-(CH<sub>2</sub>)<sub>8</sub>

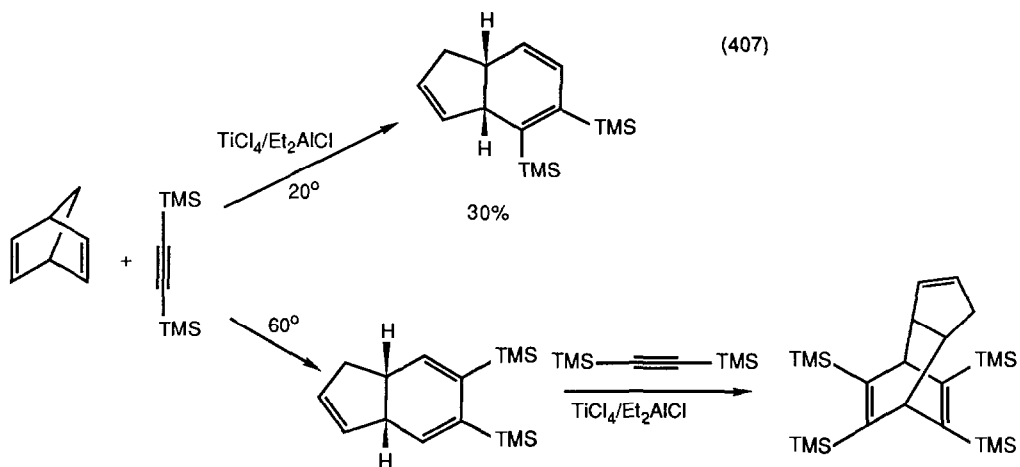
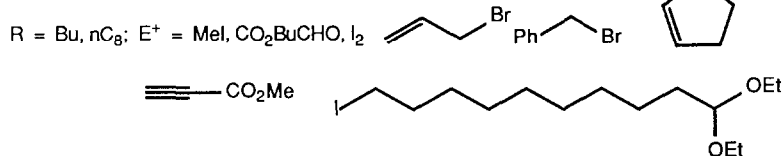
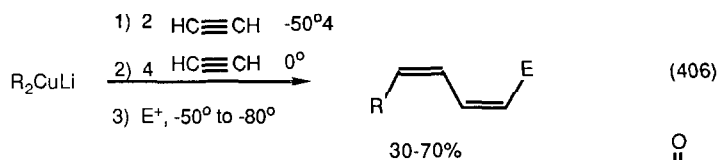

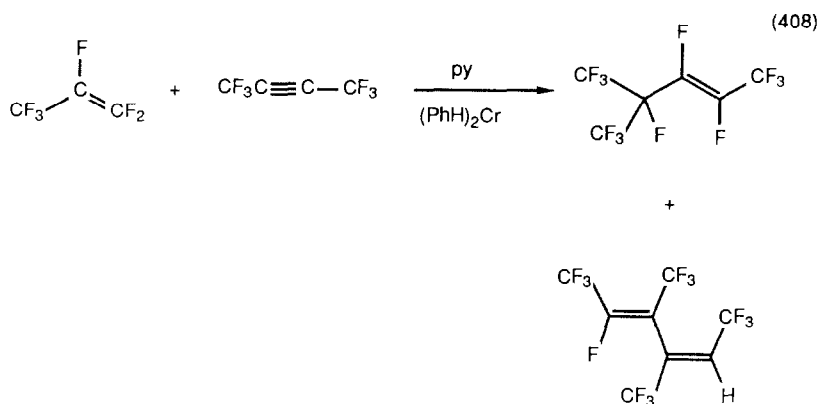

Alkynes were cyclotrimerized to arenes by  $\text{CpRhL}_2$  catalysts [464]. Reduced nickel complexes cyclotrimerized *bis*-propargyl ethers (equation 409) [465]. Phenyl acetylene was cyclotrimerized to 1,2,4-triphenylbenzene by (triisopropylphosphate) nickel tricarbonyl [466]. Propargyl alcohol was cyclotetramerized by azadiene nickel(O) complexes [467]. Low valent complexes cyclooligomerized alkynes (equation 410) [468].

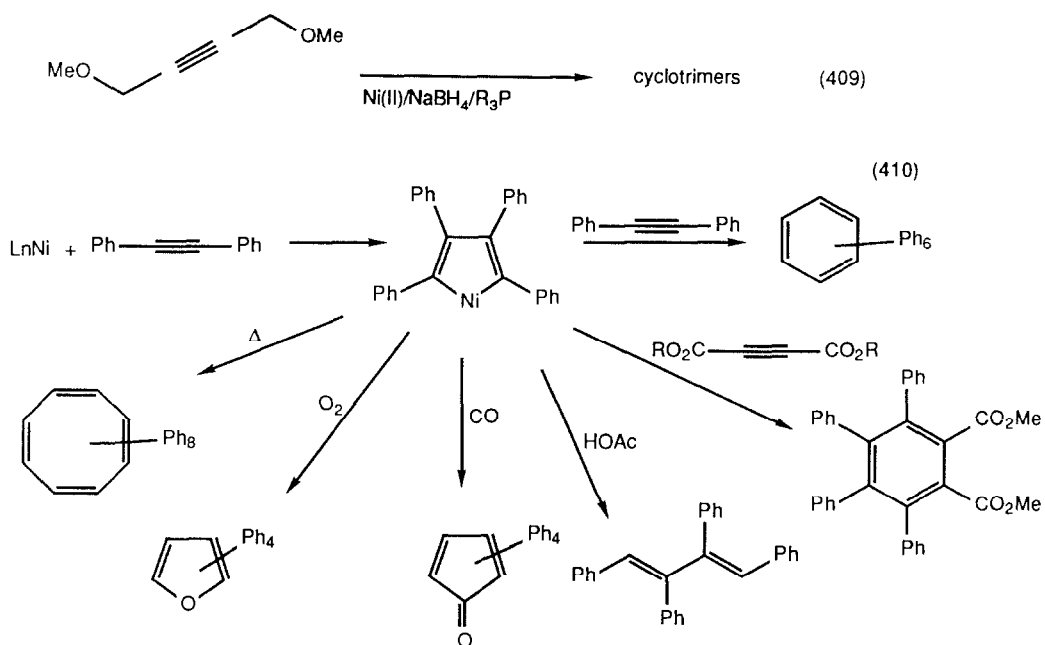

Organometallic cobalt-mediated [2+2+2] cycloaddition of polyenyne systems was the subject of a dissertation [469]. This process was used in the synthesis of a number of polycyclic systems (equation 411) [470], (equation 412) [471], (equation 413) [472], (equation 414) [473].

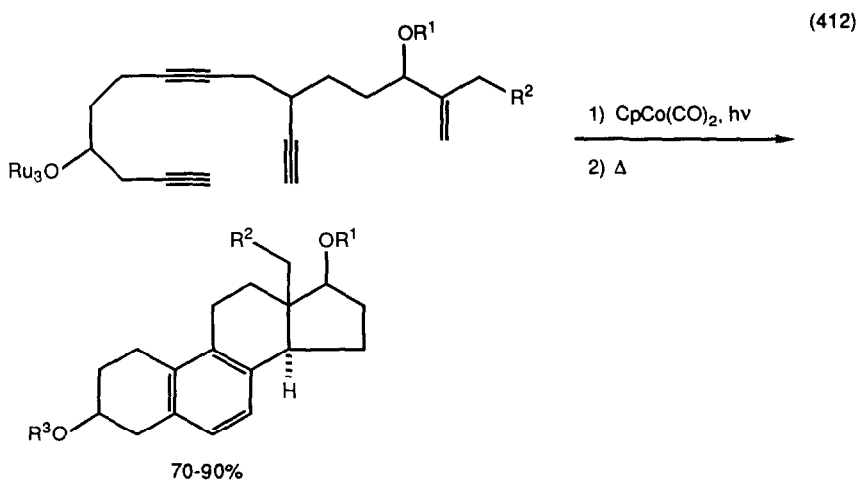
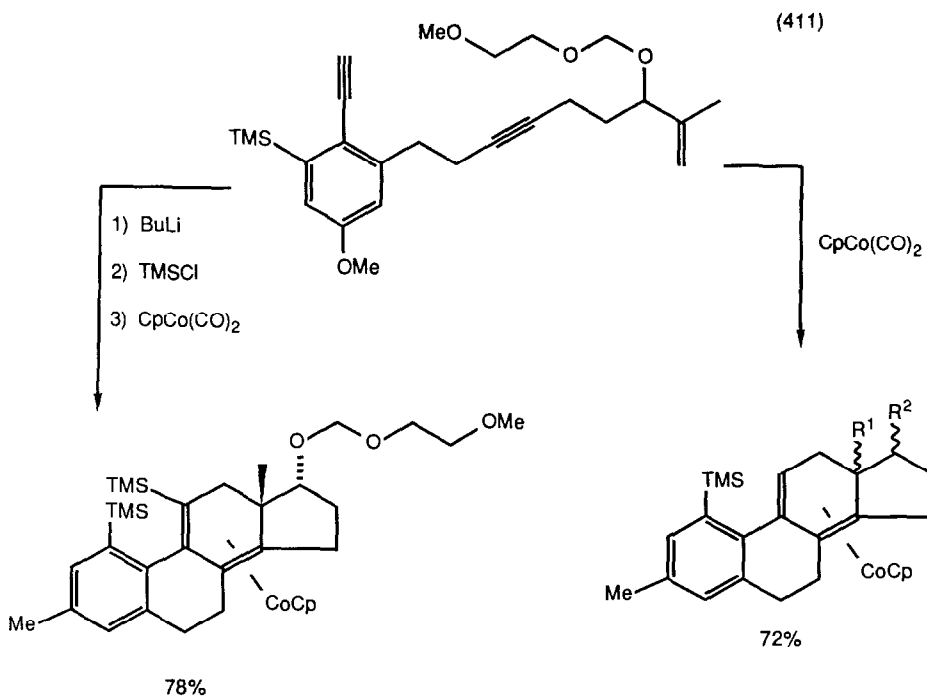

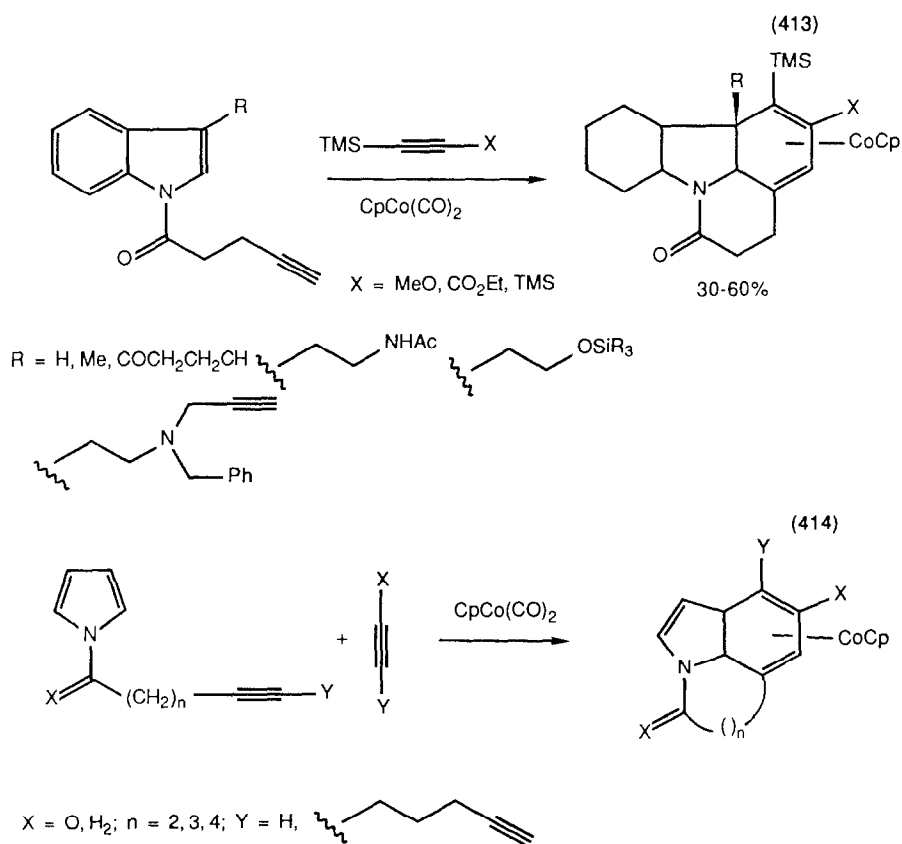

Reduced ruthenium catalysts dimerized methyl acrylate (equation 415) [474]. Triiron dodecacarbonyl dimerized conjugated enones (equation 416) [475], (equation 417) [476]. Norbornadienes were cyclooligomerized to strange ring systems by iron pentacarbonyl (equation 418) [477] and cobalt catalysts (equation 419) [478]. Radialenes were prepared by copper-catalyzed cyclooligomerization of gem-dibromovinyl halides (equation 420) [479]. Isocyanides were polymerized to helical polyimines by nickel(II) catalysts in the presence of chiral amines [480].

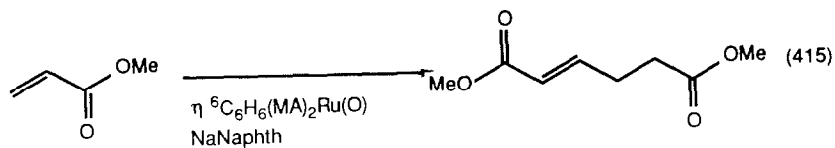

47% conversion; 49:1 linear/branched  
77% dimer



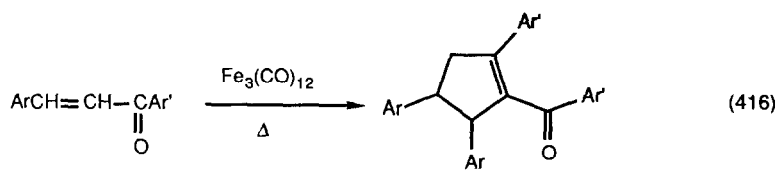

Ar = Ph, pMePh, pClPh, pMeOPh

~90%

Ar' = Ph, pMeOPh

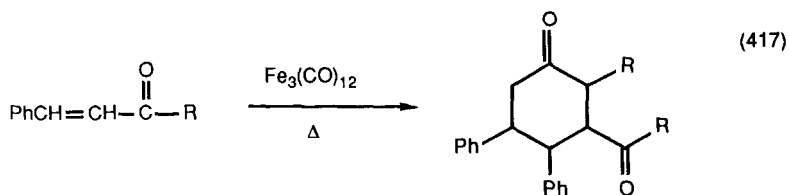

R = Me, Et, nPr, iPr

40-80%

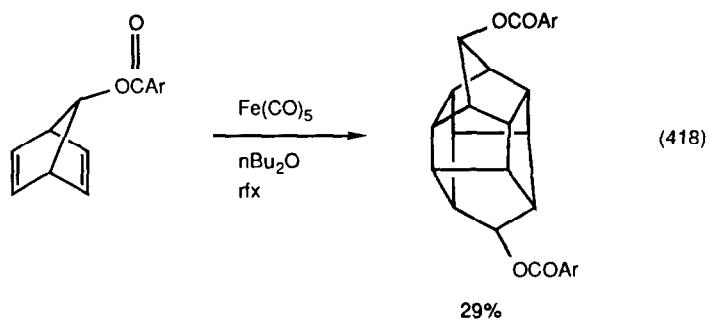

29%

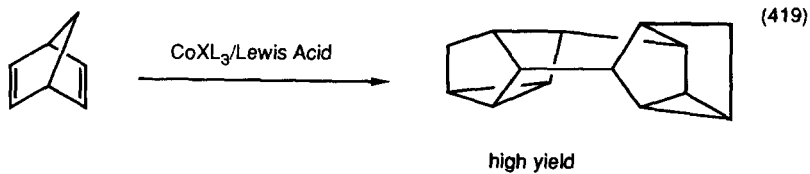

high yield

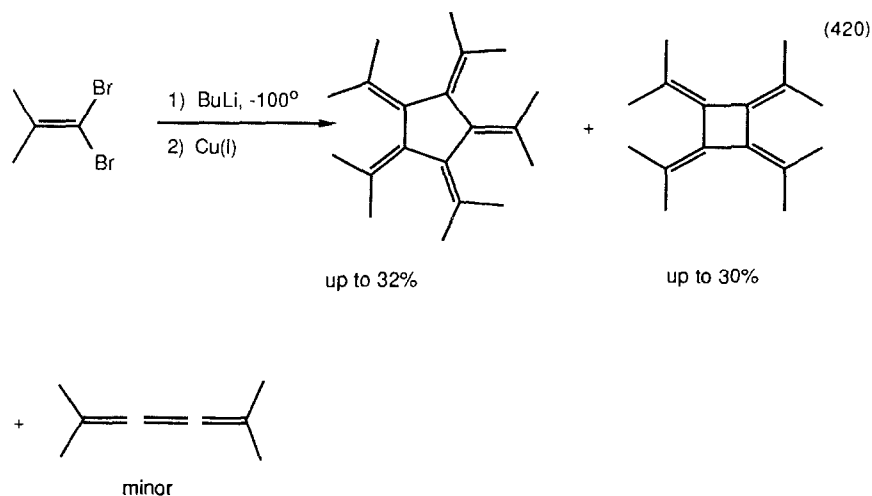

## E. Rearrangements

### 1. Metathesis

A review entitled "on the trail of metathesis catalysts" (47 references) has appeared [481], as has one dealing with catalysts for disproportionation of unsaturated linear hydrocarbons (34 references) [482], and olefin metathesis (32 references) [483]. Catalytic olefin disproportionation and other studies related to C-H activation with iridium complexes was the topic of a dissertation [484]. Metathesis of functionalized olefins has been reviewed (49 references) [485]. The catalyst system  $WCl_6/LiAlH_4$  in chlorobenzene metathesized 2-pentene, 2-hexene, and 3-heptene [486]. Propene metathesized over molybdenum-alumina catalysts [487]. The catalyst system  $WCl_6/SnMe_4$  catalyzed the metathesis of cis-2-pentene with vinyl- and allyl trimethylsilane [488]. The catalysis of hydrosilation and metathesis of vinyl-substituted silanes has been reviewed [489]. Titaniumcyclobutanes catalyzed the ring-opening polymerization of norbornene (equation 421) [490]. Tungsten carbyne complexes were effective metathesis catalysts (equation 422) [491] as was a tungsten carbene/nitrene complex (equation 423) [492]. Titaniumcyclobutanes underwent a number of reactions other than metathesis (equation 424) [493], (equation 425) [494].

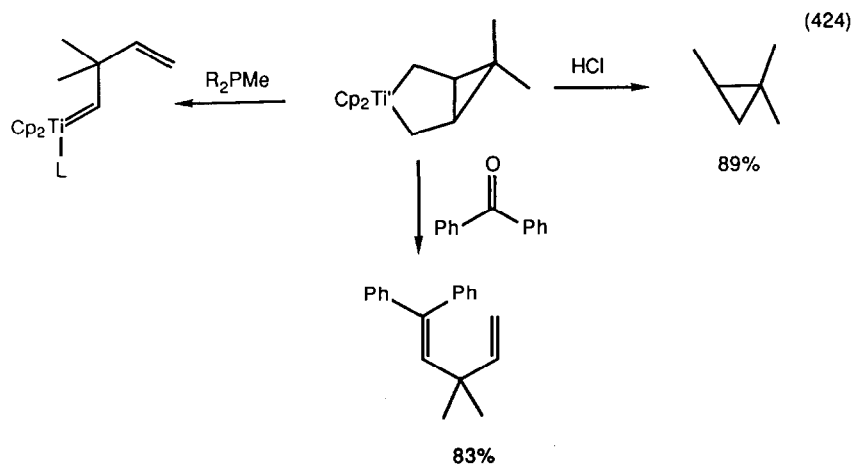
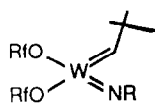
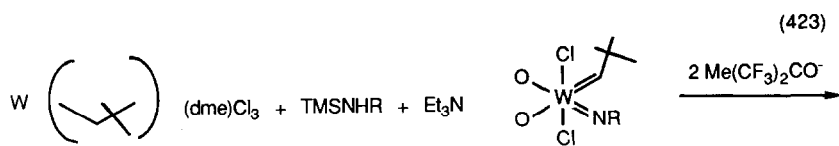
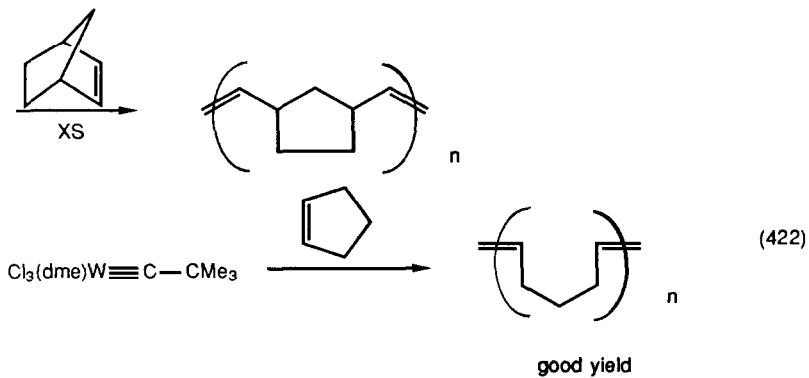
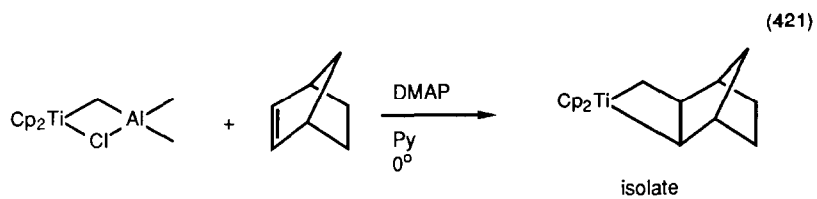

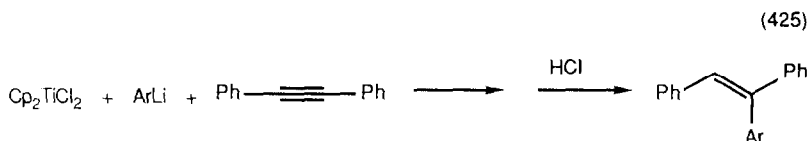

## 2. Olefin Isomerization

1-Butene was isomerized to *cis* and *trans*-2-butene by  $\eta^6\text{-C}_6\text{H}_6\text{Ni}(\text{SiCl}_3)$  and related compounds [495]. Rhodium and iridium(I) catalysts isomerized  $\omega$ -olefinic silanes to allyl silanes (equation 426) [496]. Metal clusters in the catalysis of isomerization of methyl linoleate was the topic of a review [497]. 1,5-Cyclooctadiene was isomerized to 1,3-cyclooctadiene by titanocene dichloride/Grignard reagent systems [498]. This same catalyst isomerized 1,5-hexadiene to methylenecyclopentane, methyl cyclopentane as well as all possible linear isomers [499]. Light catalyzed the isomerization of 1,5-cyclohexadiene by nickel hydride complexes [500]. Vinyl cyclohexenes were isomerized to 1,3-cyclohexadienes by iron pentacarbonyl (equation 427) [501]. This same catalyst isomerized allyl benzenes to styrenes upon irradiation [502]. Dihydrodioxepins were isomerized over chiral catalysts (equation 428) [503].

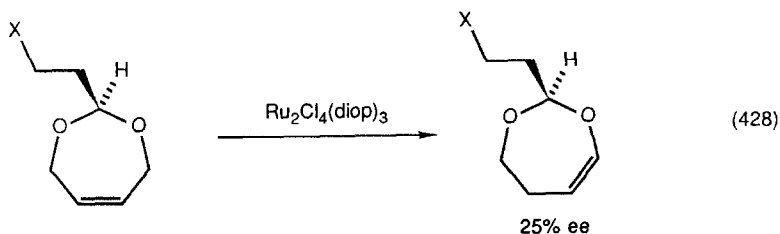
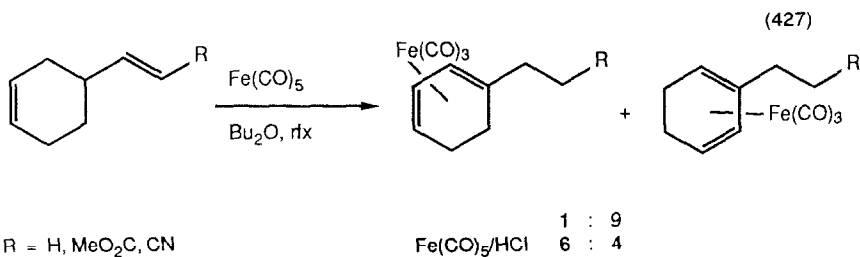
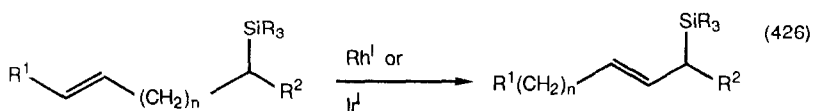

### 3. Rearrangements of Allylic and Propargylic Systems

Asymmetric isomerization of allylic compounds and mechanism was the subject of a review (20 references) [504], as was asymmetric catalytic isomerization of functionalized olefins (72 references) [505]. Allyl ethers of carbohydrates were isomerized and cleaved by *trans* [Pd(NH<sub>3</sub>)<sub>2</sub>Cl<sub>2</sub>] [506]. Allylic alcohols were isomerized by OsHBr(CO)(PPh<sub>3</sub>)<sub>3</sub> [507].

Palladium(II) chloride catalyzed the Cope rearrangement of allyl vinyl ethers to olefinic ketones (equation 429) (equation 430) [508], while nickel(II) catalyzed phosphorous oxygen to carbon allylic rearrangements (equation 431) [509], and palladium(O) catalyzed sulfur to carbon allylic rearrangements (equation 432) [510]. Enamines of allyl esters of proline also rearranged under palladium(O) catalysis (equation 433) [511].

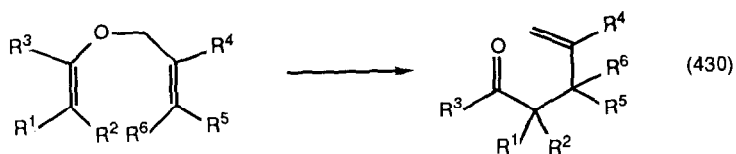
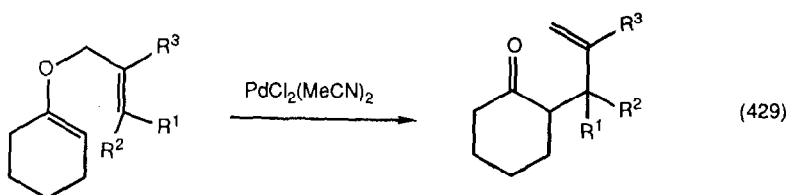

good yields only for: R<sup>1</sup> = H; R<sup>2</sup> = Me,; R<sup>3</sup> = Et; R<sup>4</sup> = R<sup>5</sup> = H; R<sup>6</sup> = Me

R<sup>1</sup> = H; R<sup>2</sup> = Me; R<sup>3</sup> = Et; R<sup>4</sup> = R<sup>5</sup> = R<sup>6</sup> = H

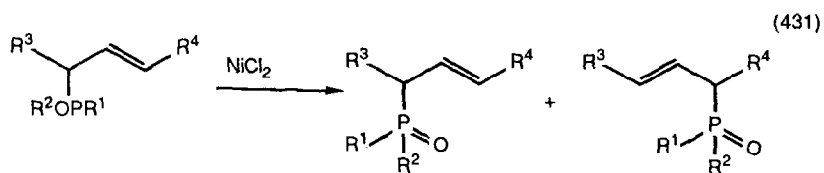

85-100%

R<sup>1</sup>, R<sup>2</sup> = Ph, Et, O-CH=CH<sub>2</sub>

R<sup>3</sup>, R<sup>4</sup> = H, Me, Ph, (CH<sub>2</sub>)<sub>3</sub>

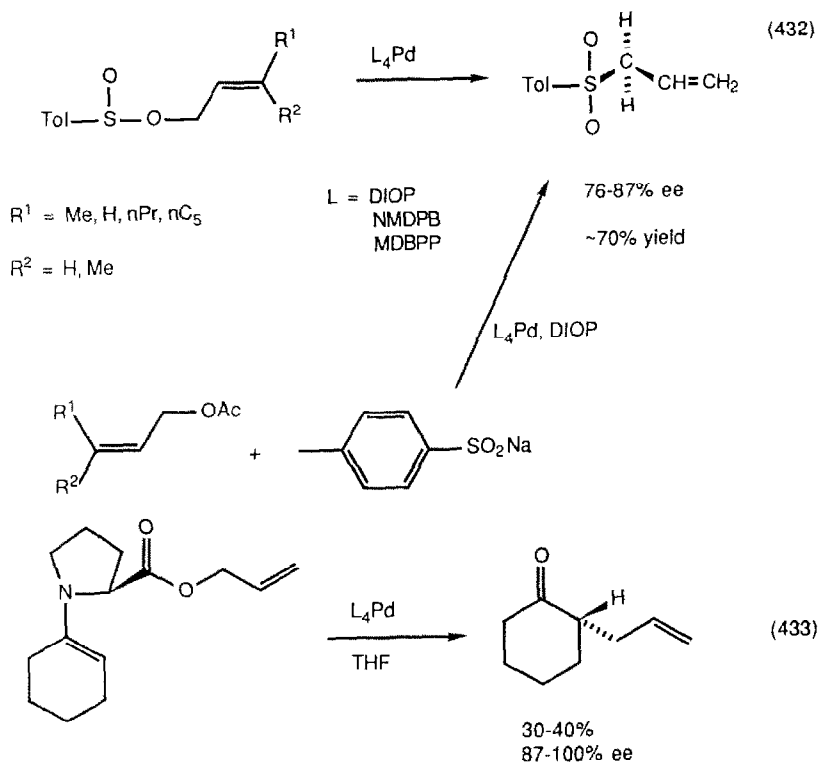

Palladium(O) catalyzed a number of allylic other rearrangements with extrusion of COS (equation 434) [512], and  $\text{CO}_2$  (equation 435) [513], (equation 436) [514], (equation 437) [515].

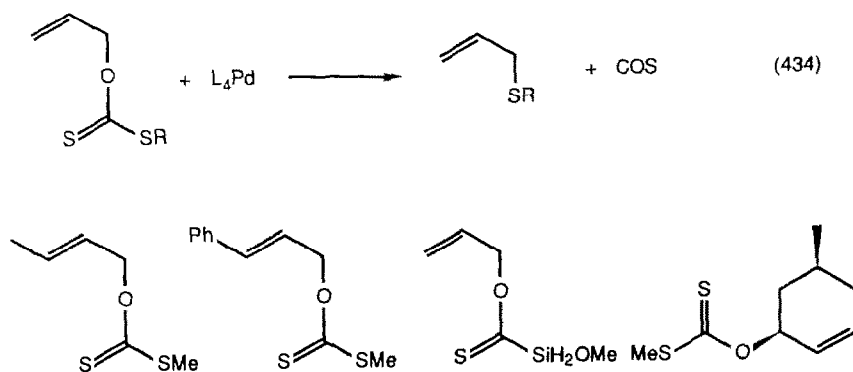

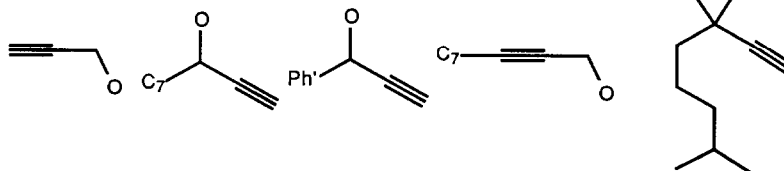
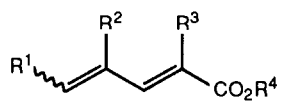
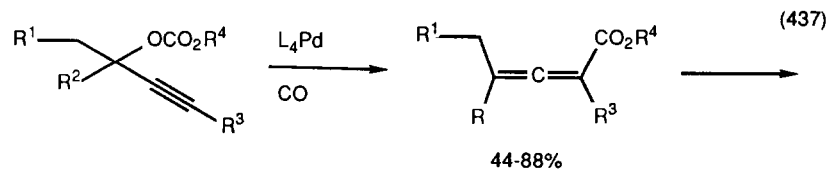
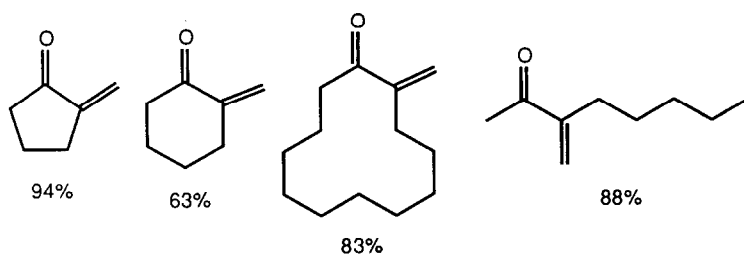
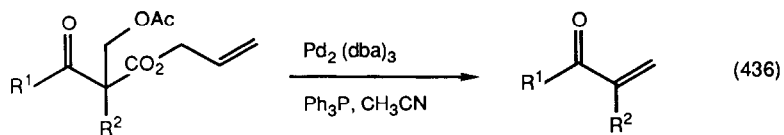
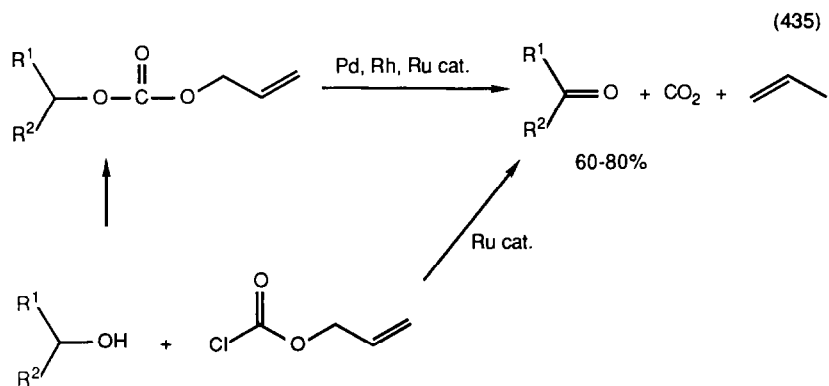

(equation 437 continued)

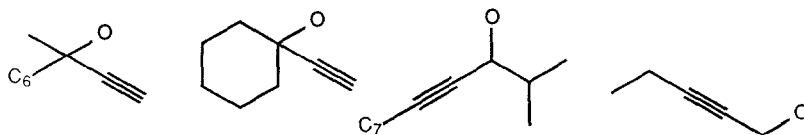

Zirconocene dichloride catalyzed [2,3]-Wittig rearrangements with high stereoselectivity (equation 438) [516], (equation 439) [518].

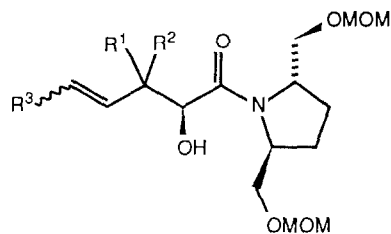
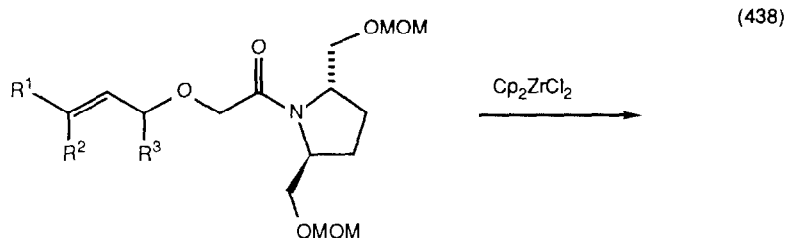

60-80%; up to 96% de  
at C<sub>2</sub>'

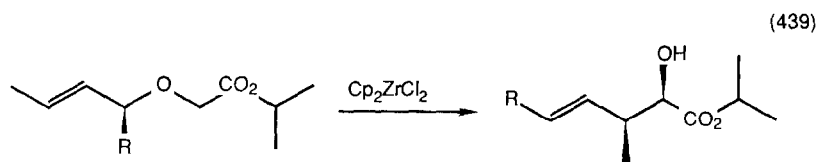

up to 96% ee of syn

R = H, Me, nBu, nC<sub>6</sub>, iPr

#### 4. Skeletal Rearrangements

Platinum catalyzed skeletal reactions of alkanes of various structures was the topic of a summary [519]. Skeletal isomerizations of alkanes over palladium and nickel catalysts appeared to proceed via carbene mechanisms [520]. A cyclobutyliron complex rearranged to a ring expanded carbene complex upon irradiation (equation 440) [521]. Palladium(II) chloride isomerized vinyl cyclopropanes to  $\eta^3$ -allyl complexes (equation



441) [522]. Nickel carbonyl rearranged vinyl cyclobutanes to cyclohexadienes (equation 442) [523], while cobalt(II) porphyrins converted bicyclobutanes to cyclobutenes (equation 443) [524], and nortricyclanes to norbornadienes (equation 444) [525].

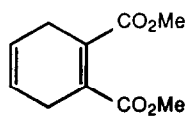
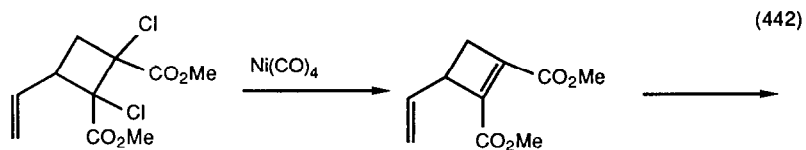
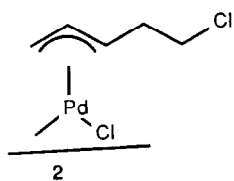
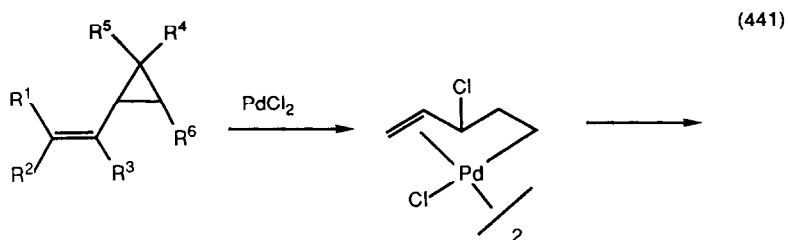
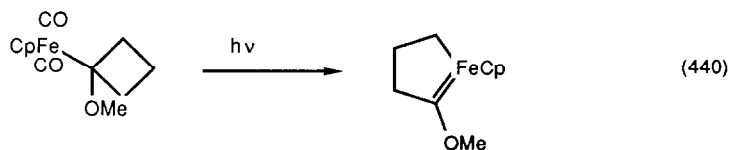

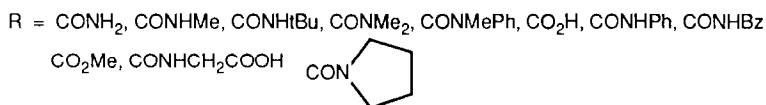
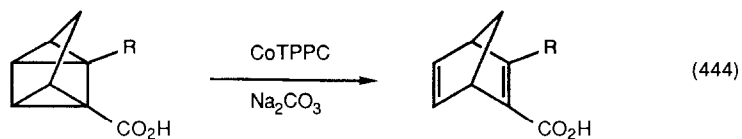
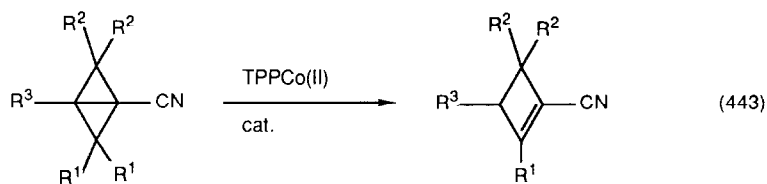

Chromium carbonyl complexes rearranged a benzocyclobutane (equation 445) [526] while reduced nickel species catalyzed a ring expansion (equation 446) [527] and palladium(II) catalyzed a ring contraction (equation 447) [528]. Molybdenum carbonyl (equation 448) [529] and iron carbonyl (equation 449) [530] catalyzed rearrangements of nitrogen heterocycles.

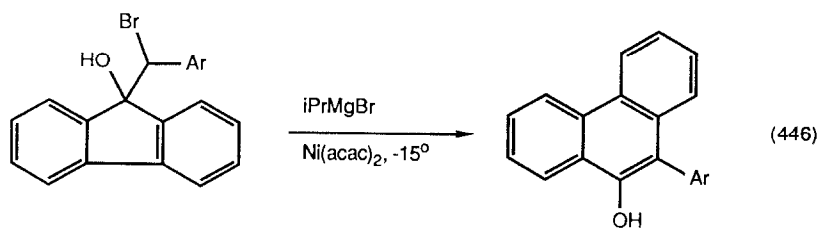
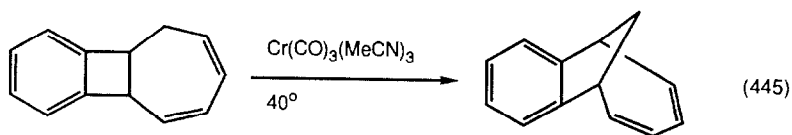

71-90%

Ar = Ph, mFPPh, mClPh, pClPh, mCHBr<sub>2</sub>, pCHBr<sub>2</sub>

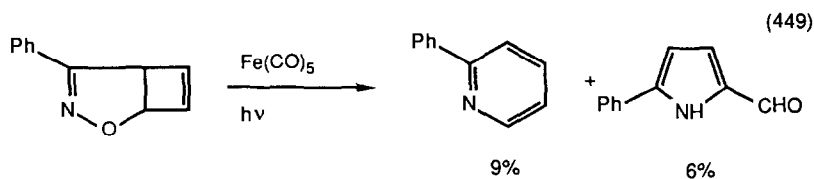
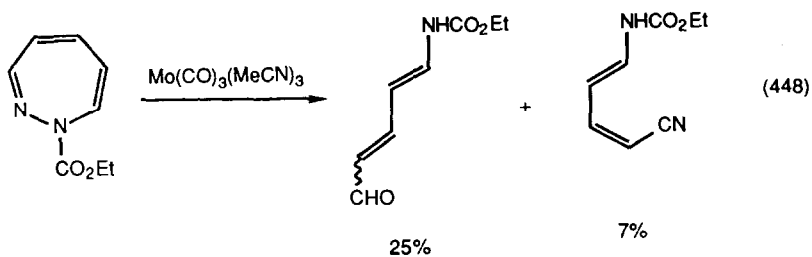
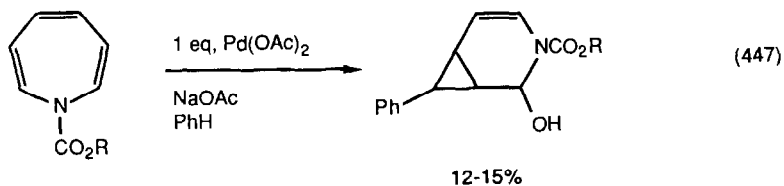

### 5. Miscellaneous Rearrangements

Nickel(II) amine complexes catalyzed the epimerization of C-2 of aldoses and selectively complexed mannose-type epimers [531]. Palladium(0) (equation 450) [532], (equation 451) [533], titanium(IV) (equation 452) [534] and nickel(II) complexes catalyzed the rearrangement of epoxides to carbonyls.

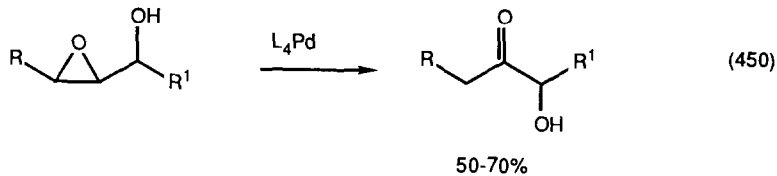

R = Ph, ptoly, pNO<sub>2</sub>P  
(fails if R = aliphatic, electron rich aromatic)

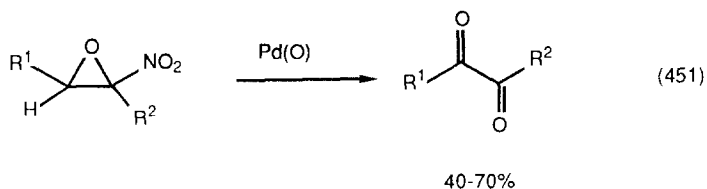

$R^1 = \text{Ph, pMePh, Me}$   
 $R^2 = \text{Me, Ph, nBu}$

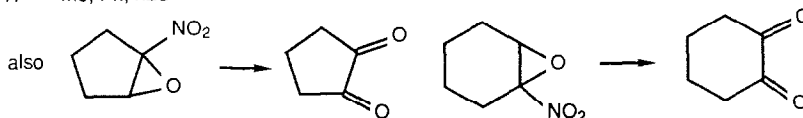

### III. Functionalized Group Preparations

#### A. Halides

Electrochemical reduction of nickel(II) bromide in *N*-methylpyrrolidinone gave a catalyst which converted aryl and alkyl bromides to iodides (equation 454) [536]. Aryl bromides were converted to iodides by potassium iodide and copper iodide (equation 455) [537]. Iron complexes catalyzed the addition of carbon tetrachloride to olefins (equation 456) [578]. Manganese(III) acetate converted cinnamic acids to trichloroethyl benzenes (equation 457) [539]. Ketones were converted to vinyl halides via their triflates by a palladium catalyzed stannylation/bromination (equation 458) [540]. Complexation to cobalt was used to protect the alkyne in enynes during bromination of the alkene (equation 459) [541]. Epoxides were opened to chlorohydrins by  $\text{Li}_2\text{CuCl}_4$  (equation 460) [542].

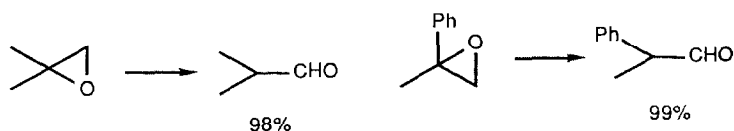
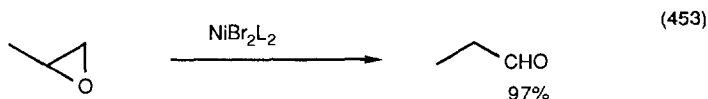
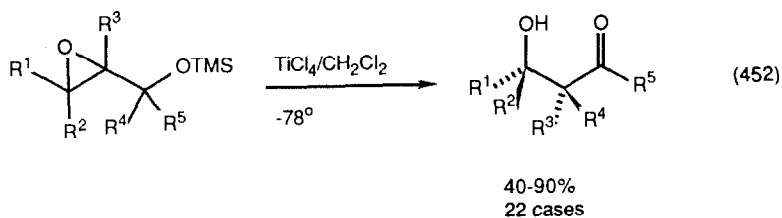

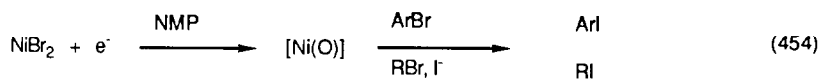

Ar = Ph, pMeOPh, oMeOPh, mMeOPh, pMePh, pFPh, Ph

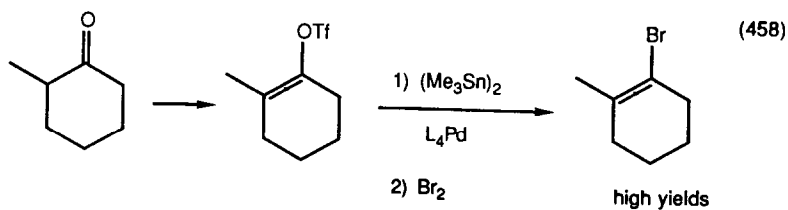
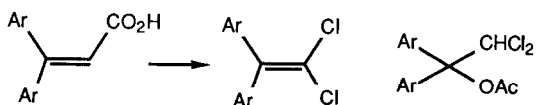
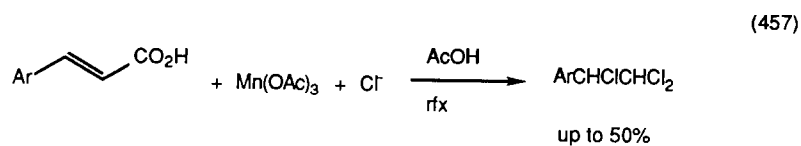
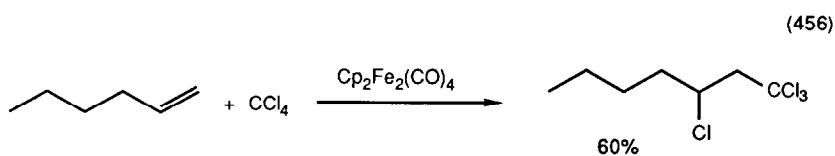
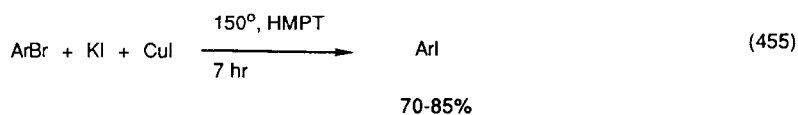
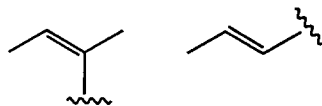

(equation 458 continued)

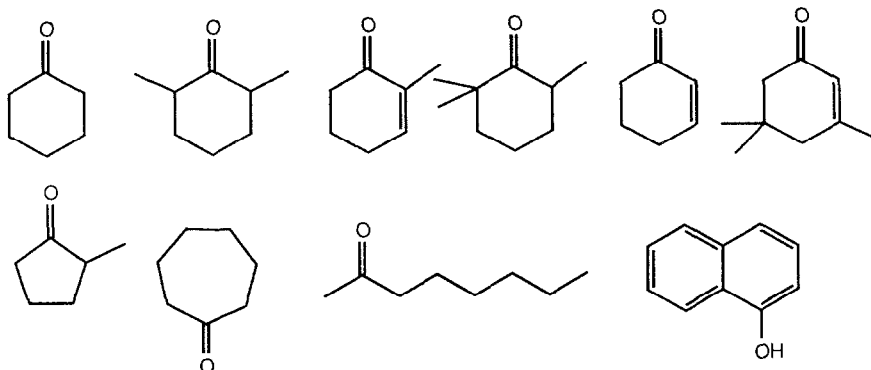

(459)

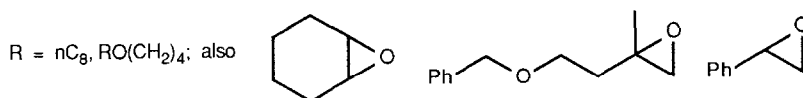
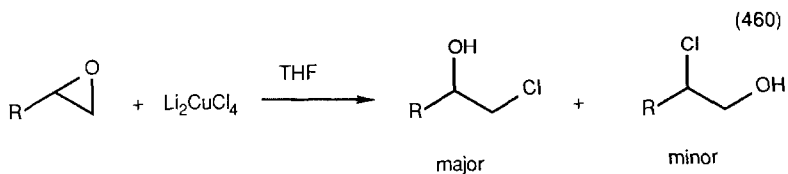
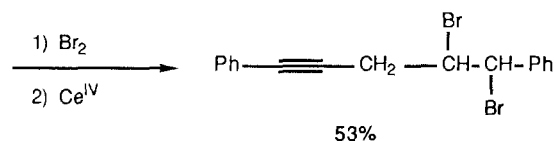
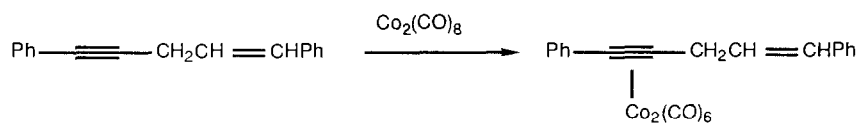

## B. Amides, Nitriles

Nickel(O) complexes catalyzed the reaction between olefins and isocyanates to give unsaturated amides after cleavage (equation 461) [543][544]. Ruthenium clusters catalyzed the reduction dimerization of isocyanates to N-formylureas (equation 462) [545]. Ruthenium tetroxide oxidized N-protected amines to amides (equation 463) [546]. Ruthenium hydrides catalyzed the reaction between nitriles, amines and water to give amides (equations 464 and 465) [547]. Diperoxycarbamates were prepared by the copper catalyzed reaction of hydroperoxides with isocyanates [548].

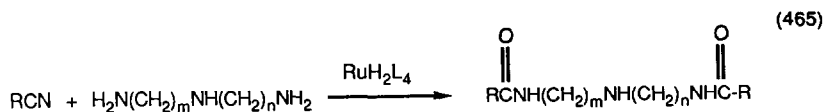
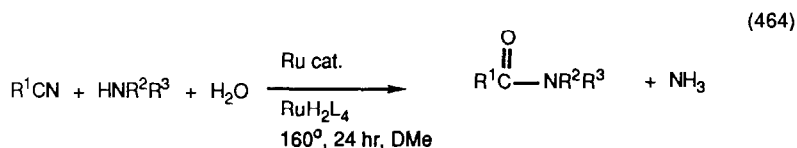
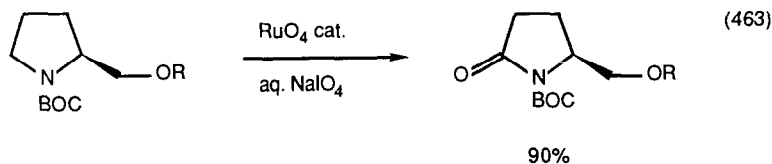
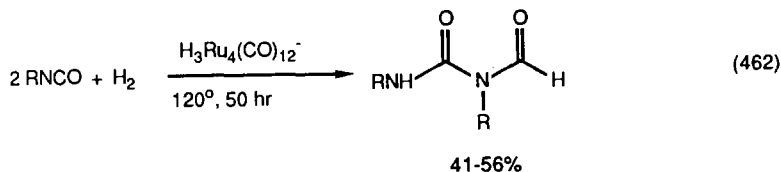

The hydrocyanation of alkynes has been reviewed (8 references) [549] as has homogeneous nickel-catalyzed olefin hydroxyanation (73 references) [550], and metal catalyzed stereoselective additions of hydrogen cyanide and other small molecules to alkenes and alkynes (12 references) [551]. The nickel(O) catalyzed addition of HCN to olefins (equation 466) and dienes (equation 467) [552] has been shown to go with *cis* stereochemistry. Aryl iodides were converted to aryl cyanides by trimethylsilylcyanide in the presence of palladium(O) catalysts (equation 468) [553].

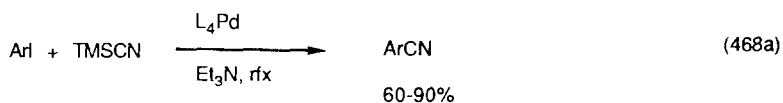
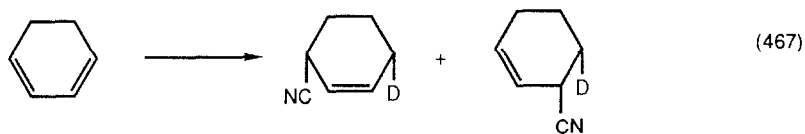
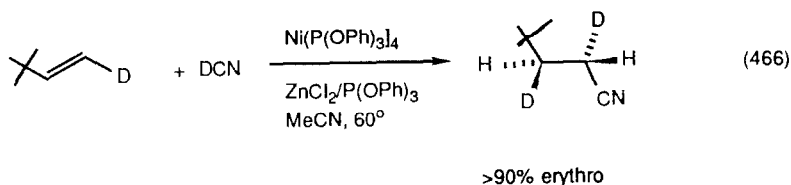

Ar = Ph, oMePh, pMeOPh, pClPh, pBrPh, pMeO<sub>2</sub>CPh

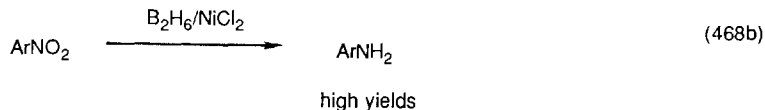

Ar = pMeOPh, pCNPh, pCNCH<sub>2</sub>Ph, pMeO<sub>2</sub>CPh, pH<sub>2</sub>NCOPh

tolerates: C=O, CHO, CO<sub>2</sub>R, CONR<sub>2</sub>, CN, C=C

### C. Amines, Alcohols

Arylnitrocompounds were reduced to anilines by diborane/nickel(II) chloride (equation 468) [554]. Copper(II) catalyzed a similar nitro group reduction by borohydride (equation 469) [555]. Palladium(II) quinoline complexes catalyzed the homogeneous hydrogenation of nitroarenes to anilines [556].  $\alpha,\beta$ -Unsaturated nitro compounds were reduced to oximes by sodium hypophosphate using a palladium catalyst [557]. Rhenium oxo complexes required high hydrogen pressures to reduce nitrobenzene [558]. Palladium(O) catalyzed the reaction of bromobenzene, *t*-butylisocyanide and alkyl tin reagents to give imines (equation 470) [559].



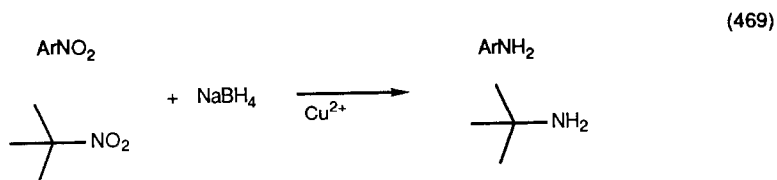

CN, CO<sub>2</sub>R, CONH<sub>2</sub>, inert

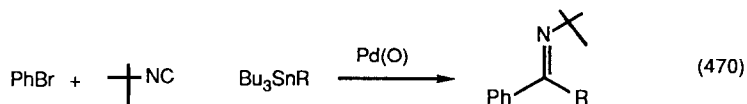

R = OMe, OEt, NEt<sub>2</sub>, CN, C≡CPh

Platinum/tin systems catalyzed the reaction between allyl alcohols and amines to give allyl amines (equation 471), while ruthenium catalysts effected further conversions (equation 472) [560]. Palladium(O) complexes catalyzed the conversion of allyl acetates to allyl azides or amines (equation 473) [561]. The same catalyst promoted the 1,4-amination of butadiene (equation 474) [562]. Aryl halides were converted to aryl amines by reaction with aminotin compounds in the presence of palladium(O) catalysts [563]. Copper(I) or nickel(II) salts promoted the amination of quinolinoquinones (equation 475) [564]. Early transition metal azide complexes (eg. Ti, V) catalyzed the ring opening of epoxides by trimethylsilyl azide [565].

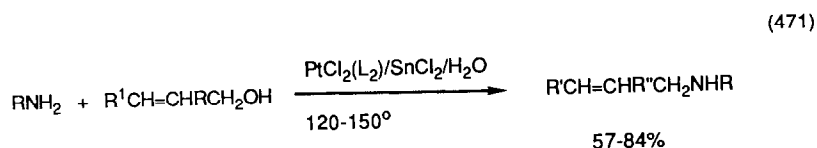

R = Ph, nC<sub>8</sub>; R' = H, Me; R'' = Me, H

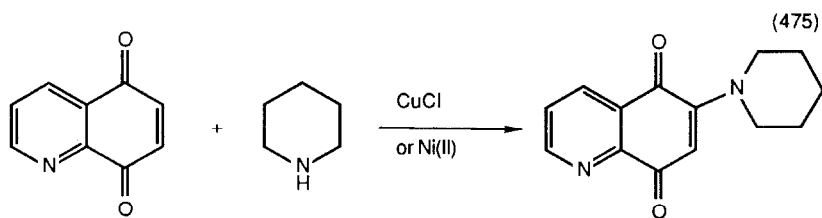
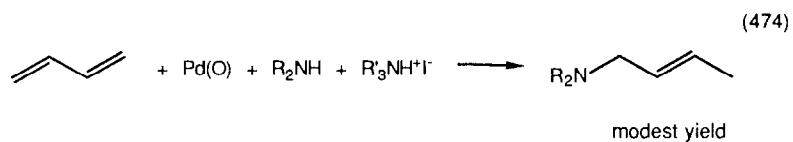
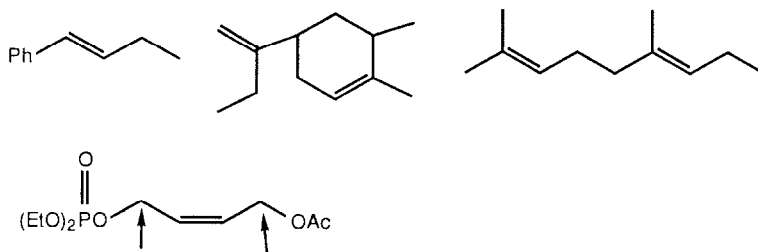
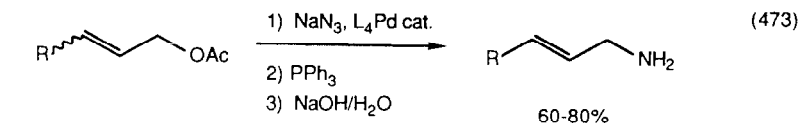
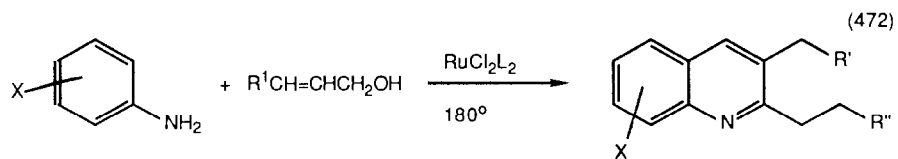

Oxidation of alkenes-metal induced formation of an allylic-carbon oxygen bond - was the topic of a review (190 references) [566]. Enolates of esters of chiral alcohols were  $\alpha$ -oxygenated to  $\alpha$ -hydroxy esters by "MoOPh" with high ee (equation 476) [567]. Ethyl esters were similarly  $\alpha$ -oxidized [568]. Amines were converted to alcohols by reaction with  $\text{Na}_2\text{-Fe}(\text{CN})_5\text{NO}$  (equation 477) [569]. 1,2-Aminoalcohols were converted to epoxides by this reagent (equation 478). Chiral diols were prepared by the oxidation of olefins by osmium tetroxide in the presence of chiral diamines (equation 479) [570], (equation 480) [571]. Cyclopentadienyl zirconium dihydride catalyzed the "Meerwein Ponderf Veerly" reduction of ketones to alcohols by isopropanol [572]. Vaska's compound,  $\text{L}_2\text{IrCl}(\text{CO})$  catalyzed the conversion of formate esters to alcohols and carbon monoxide (equation 481) [573]. Palladium(O) catalyzed the reduction of conjugated epoxides to allylic alcohols by formic acid (equation 482) [574]. Styrene was hydroxylated to  $\alpha$ -phenethyl alcohol by an oxygen/Co(II)TPP/borohydride system [575].

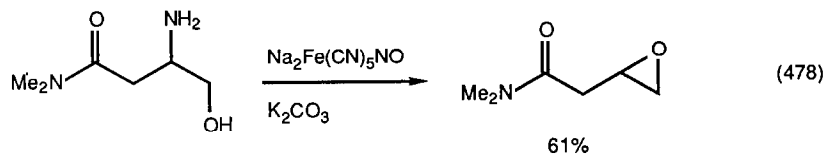
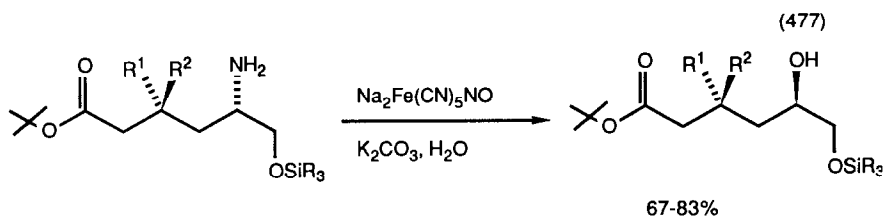
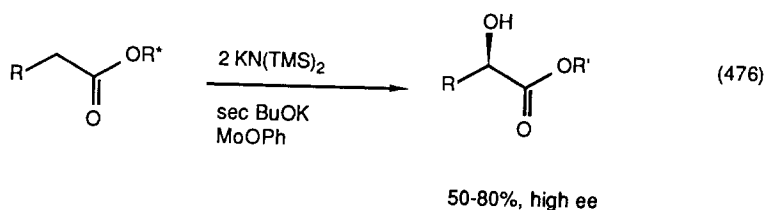

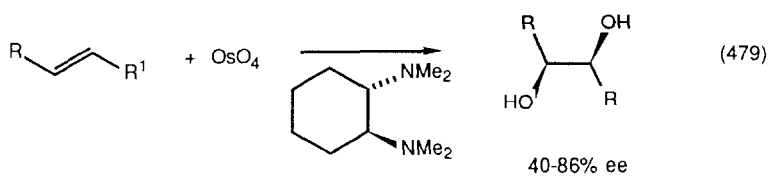

R = H, nC<sub>5</sub>, Ph, CO<sub>2</sub>Me

R<sup>1</sup> = H, Ph

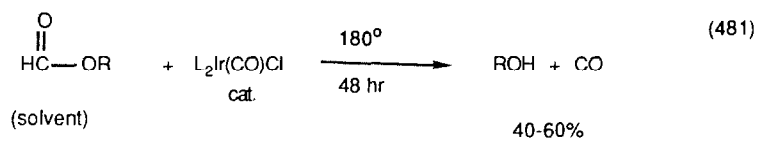
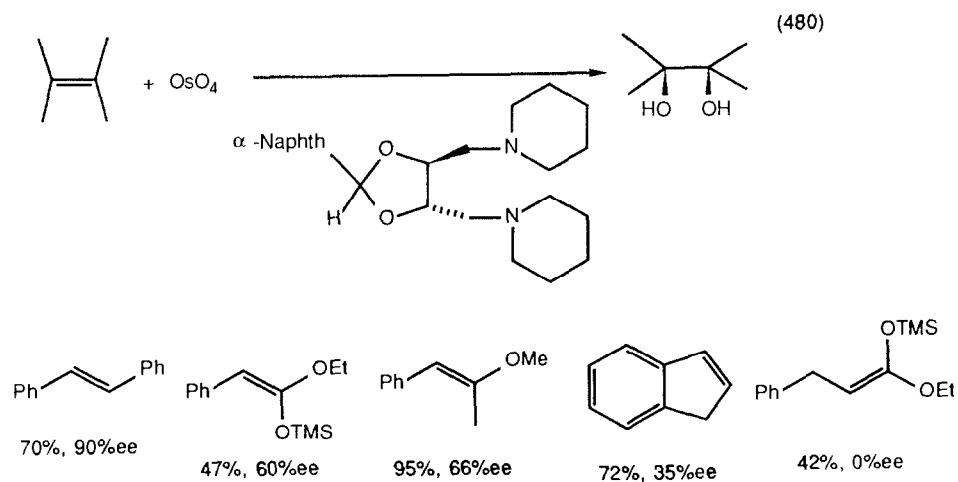

R = Me, nBu, tBu, nC<sub>7</sub>, 2-C<sub>7</sub>, nC<sub>8</sub>, 2-C<sub>8</sub>, PhCH<sub>2</sub>

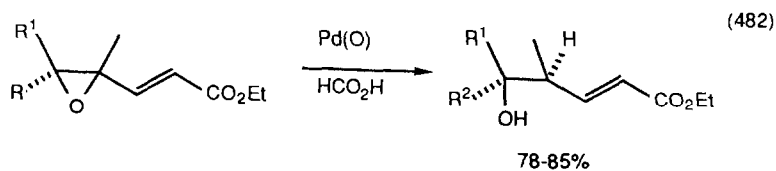

## D. Ethers, Esters, Acids

1,2-Dimethoxyethylene complexed to iron exchanged with (R)(R)-2,3-butane diol to produce a chiral complex which was further transformed (equation 483) [576]. Cobalt carbonyl catalyzed the conversion of oxetanes to silyl ethers (equation 484) [577]. Palladium(II) chloride/copper(II) chloride mixtures converted butadiene to 1,4-dibutoxy-2-butene (equation 485) [577]. Copper aryloxides converted carbon disulfide to tetraaryloxymethane (equation 486) [579]. Palladium chloride catalyzed the  $\alpha$ -methoxylation of afused furan (equation 487) [580]. Unsymmetrical diaryl ethers were made by nucleophilic attack of phenoxides on manganese complexed chlorobenzene (equation 488) [581].

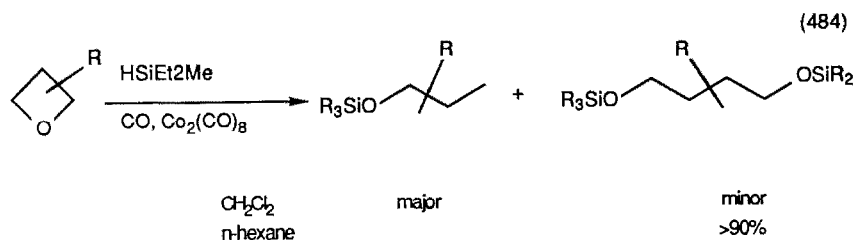
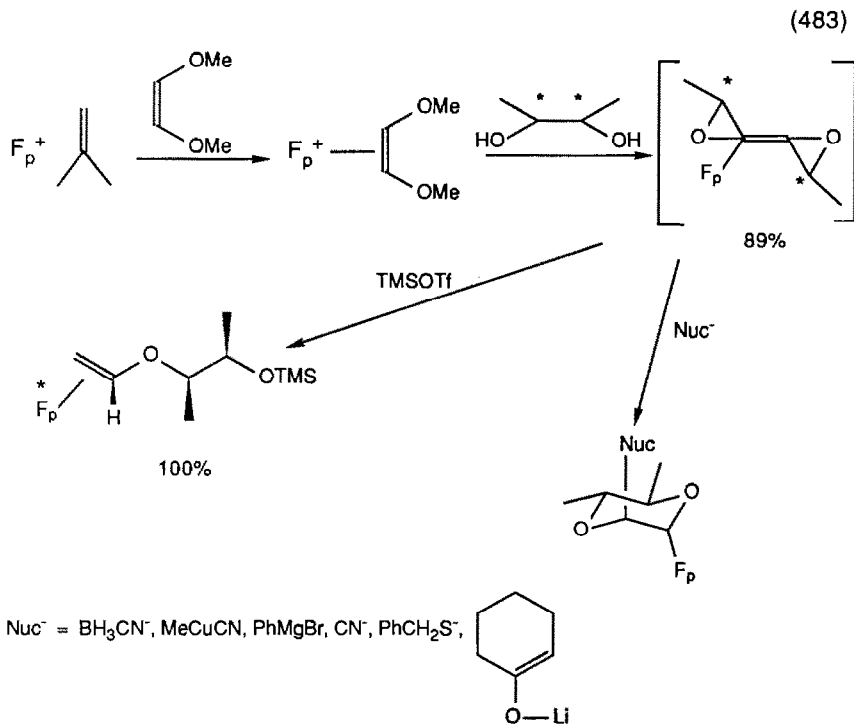

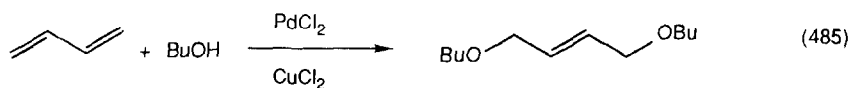

Ar = Ph, pMePh, pEtOPh, pMeOPh, pMeO<sub>2</sub>CPh, pClPh, mMePh

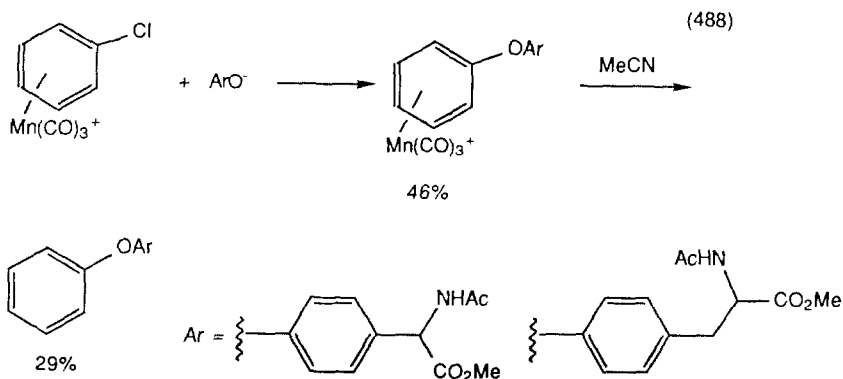
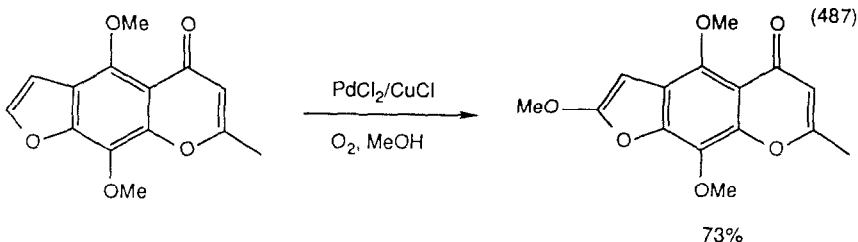

Palladium acetate catalyzed the conversions of amino acid carbamates to silylcarbamates with inversion at the chiral center (equation 489) [582]. Palladium(II) copper(II) catalysts promoted the acetoxylation of olefins (equation 490) [583]. An ester group was introduced  $\alpha$  to the nitrogen in  $\beta$ -lactams by hydroperoxides and copper(I) salts (equation 491) [584]. Peracids oxygenated benzene in the presence of cobalt(II) catalysts (equation 492) [585].

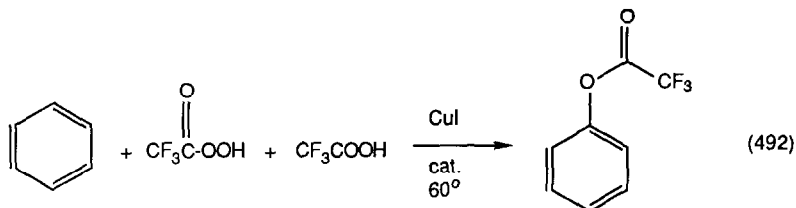
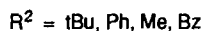
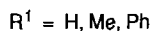
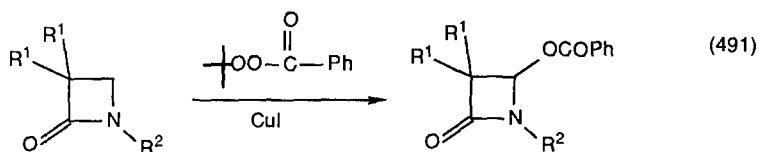
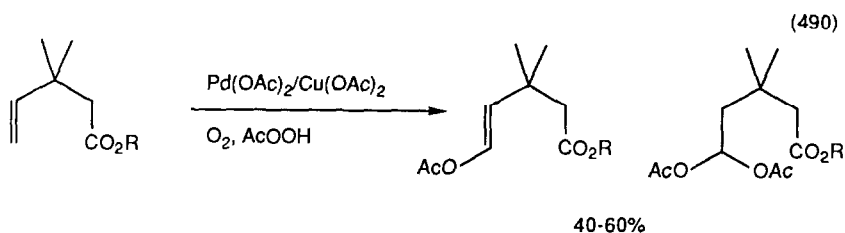
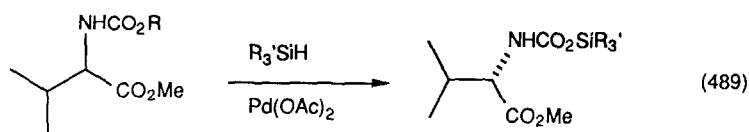

56% yield  
at 58% conversion

Ruthenium complexes catalyzed the reaction between alkynes and carboxylic acids to produce enol esters (equation 493) [586], (equation 494) [587]. Phenoxy esters were converted to alkyl esters or ketones over cobalt catalysts (equation 495) [588]. Ruthenium tetroxide oxidized cyclic lactams imides or  $\omega$ -carboxy amides (equation 496) [589]. Malonic acids were readily decarboxylated by small amounts of copper(I) salts in acetonitrile (equation 497) [590].

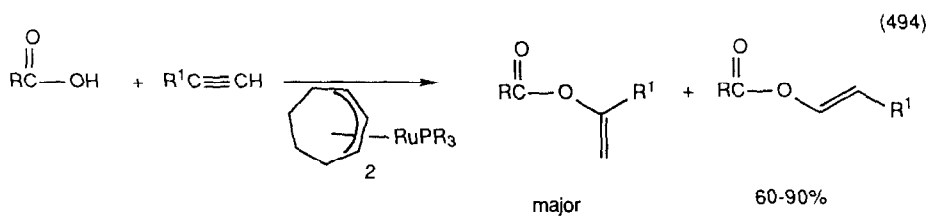
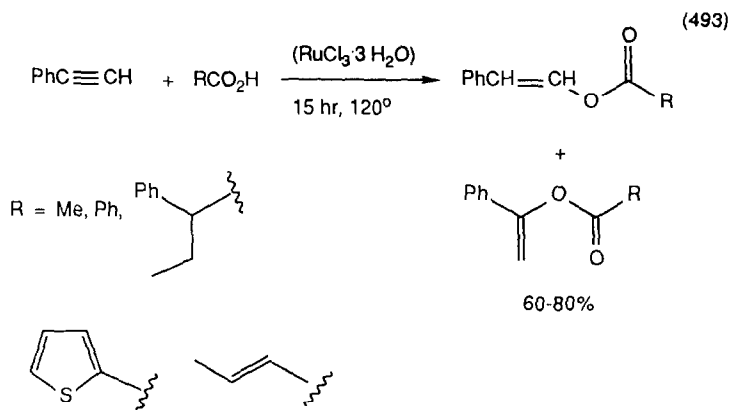

R<sup>1</sup> = nBu, tBu, Ph

R = Me, Et, iPr, tBu, 1-adamantyl, nC<sub>17</sub>, PhCO, PhCH(OH),

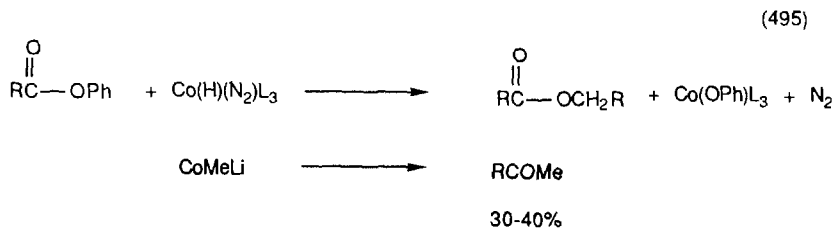
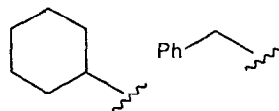
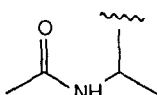
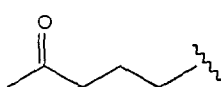



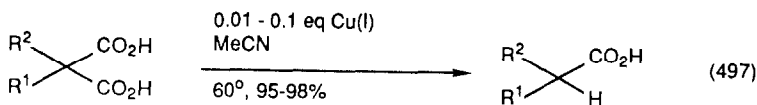
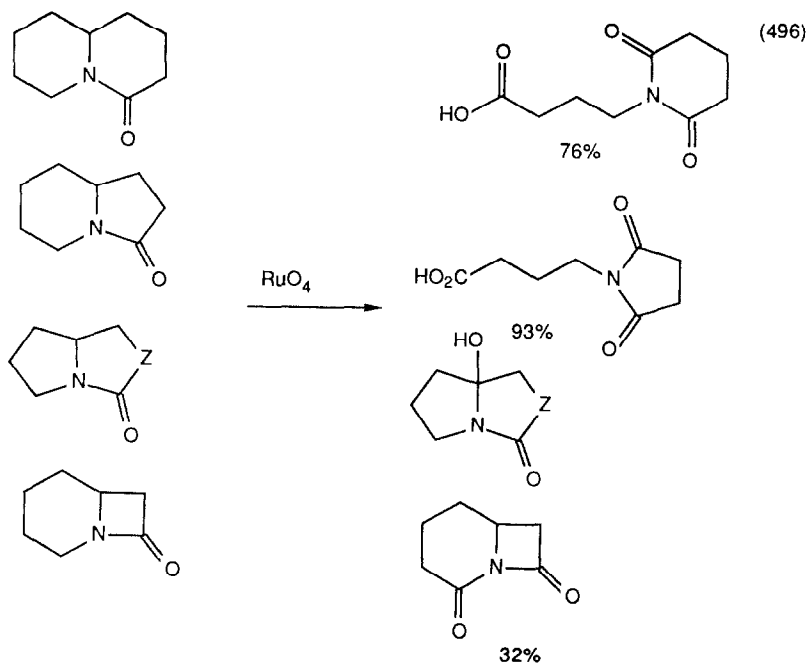

### E. Heterocycles

The synthesis of heterocycles via transition metal chemistry has been reviewed (9 references) [591]. Net [3+2]-type heterocyclic syntheses via organostannanes and palladium chemistry was the topic of a dissertation [592]. Sharpless asymmetric epoxidation of olefins has been extensively reviewed this year. The following reviews have appeared. "Development of Sharpless asymmetric epoxidation - a wonderful organic synthesis method for optical purity" (no references); "The discovery of the asymmetric epoxidation" (22 references); "On the mechanism of asymmetric epoxidation with titanium-tartrate catalysts" (104 references); "Asymmetric epoxidation of allylic alcohols: the Sharpless epoxidation" (105 references); "Asymmetric epoxidation" (19 references); "Procedure for catalytic asymmetric epoxidation of allylic alcohols in the presence of molecular sieves"; "Asymmetric epoxidation" (24 references).

This chemistry continues to be extensively used in synthesis (equation 498) [599]. Darvon alcohol (equation 499) [600], (R)(+)- $\alpha$ -Lipoic acid (equation 500) [601],  $\beta$ -blockers (equation 501) [602], and even carbohydrate-like molecules (equation 502) [603] were made using asymmetric epoxidation.

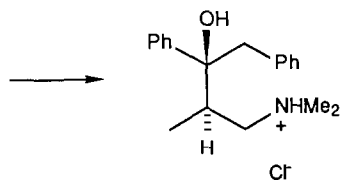
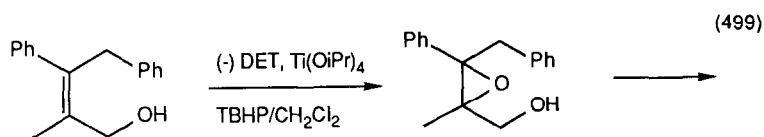
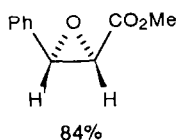
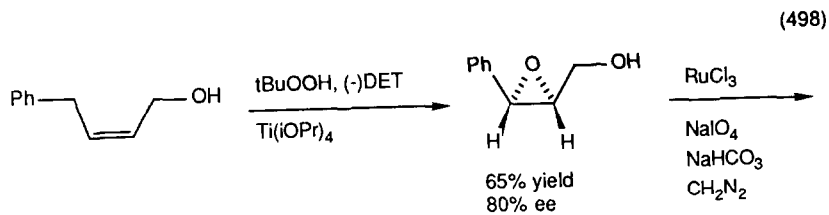

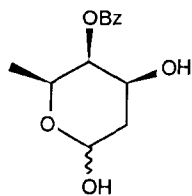
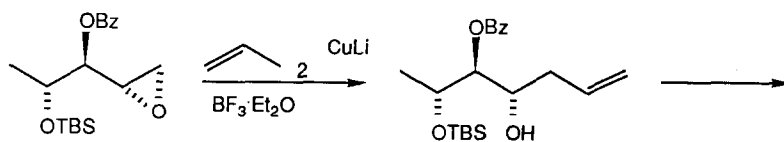
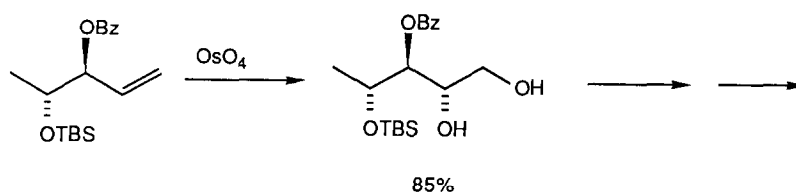
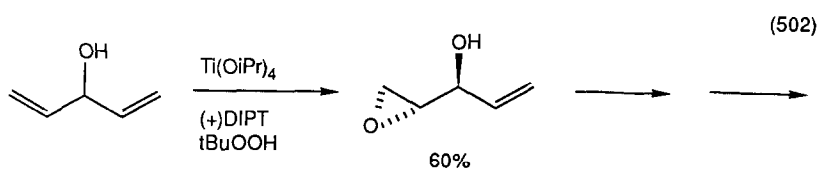
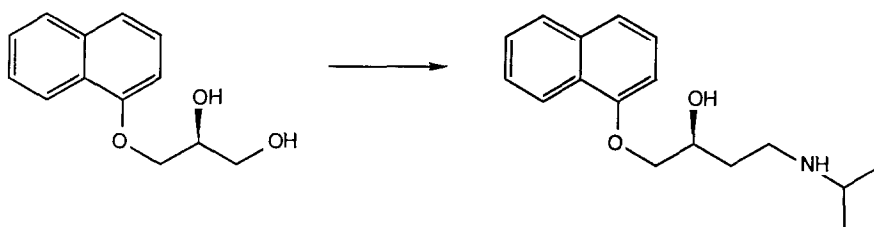
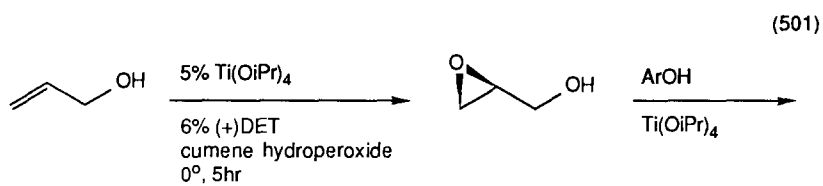

Advances in the development of methods for the epoxidation of olefins was the topic of a review (225 references) [604]. Allyl hydroperoxides were converted to epoxides by treatment with titanium(IV) isopropoxide (equation 503) [605]. Enol carbamates were epoxidized by t-butyl hydroperoxide/vanadium acetylacetonide (equation 504) [606]. An isolated, characterized vanadium hydroperoxide complex efficiently epoxidized olefins (equation 505) [606].

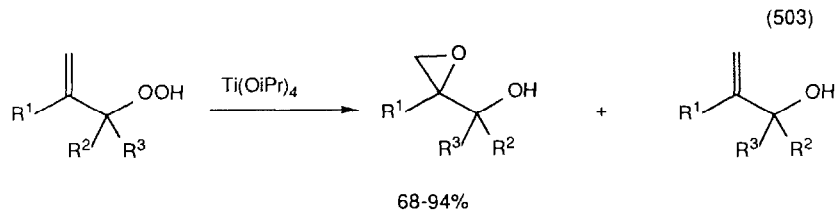

$R^1 = t\text{Bu, Me, CO}_2\text{Et}$

$R^2 = \text{H, tBu, Me}$

$R^3 = \text{H, Me}$

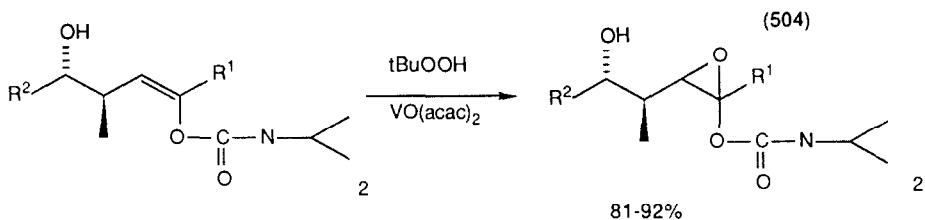

$R^1 = \text{H, Me}$

$R^2 = i\text{Pr, Me, Ph}$

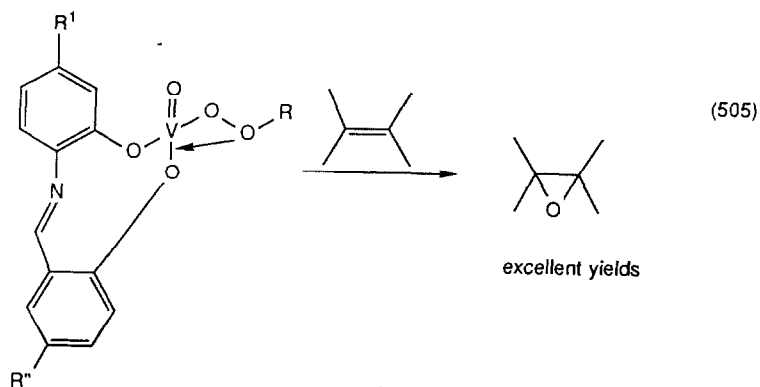

(equation 505 continued)

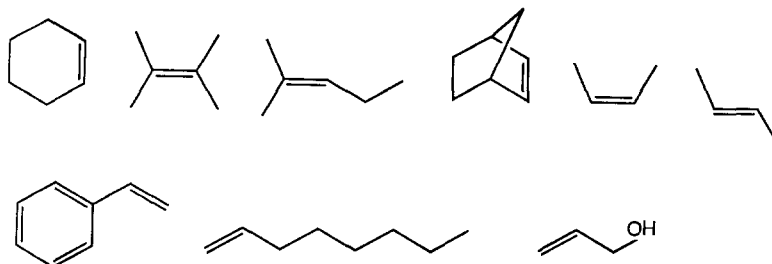

Peroxytungstate (equation 506) [608], and tungstic acid (equation 507) [609] catalyzed the epoxidation of olefins. The stereochemistry of allyl alcohol epoxidation by  $\text{H}_2\text{O}_2/\text{WO}_4^-$  gave the same major diastereoisomer as did  $\text{VO}(\text{acac})_2/\text{tBuOOH}$  but homoallylic alcohols were epoxidized with much less stereoselectivity [610].  $\omega$ -Olefinic fatty acids were epoxidized by peroxide/tungstate, carbonylated by dicobalt octacarbonyl, and cyclized (equation 508) [611]. Heteropolytungstates catalyzed the epoxidation of olefins by iodosyl benzene (equation 509) [612], as did manganese(III) salen complexes (equation 510) [613].

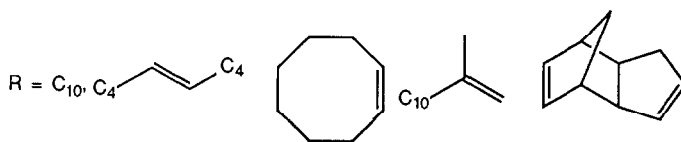
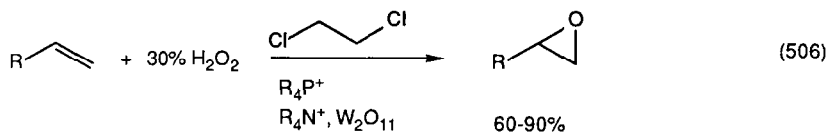

nerol, geraniol, carvone, limonene, cholesterol acetate

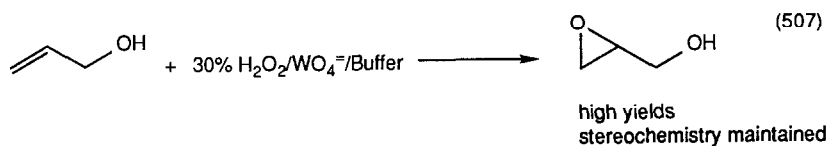

(equation 507 continued)

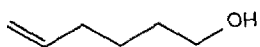
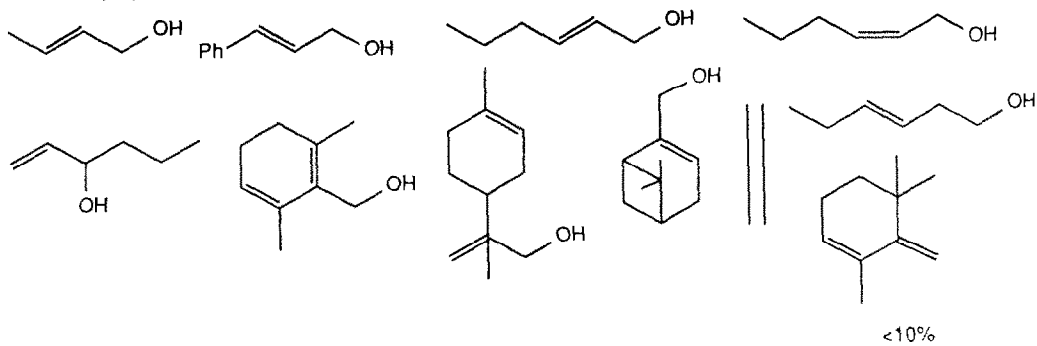

&lt;10%

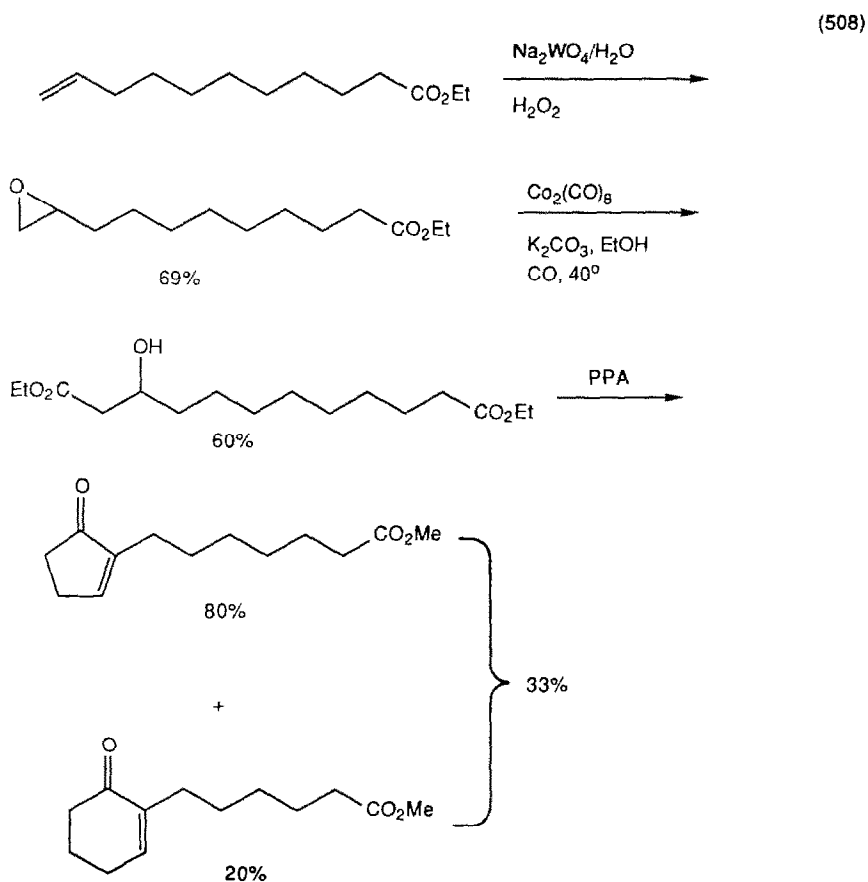

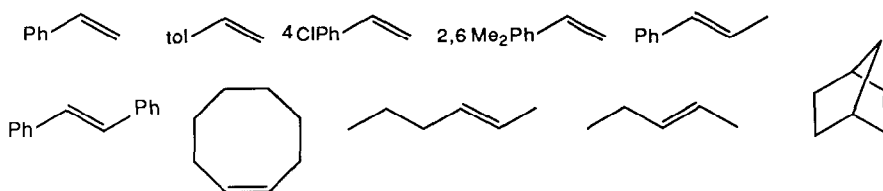
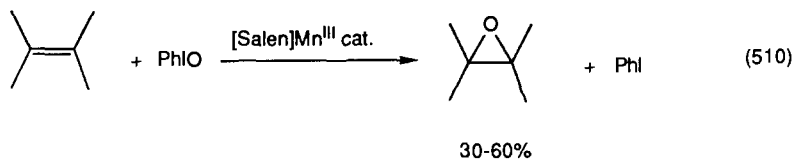
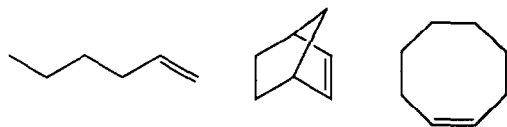
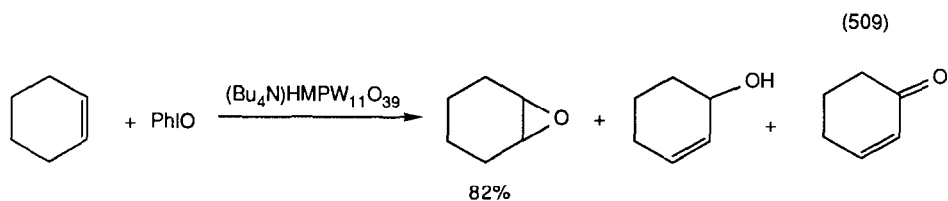

Iron(III) complexes of fluorine and nitrosubstituted tetraphenylporphyrins catalyzed the epoxidation of styrene,  $\alpha$ -methyl styrene, cyclohexene and cycloheptene by hypochlorite [614]. Manganese(III) complexes of nicotinamides of orthophenylenediamine catalyzed olefin epoxidation (equation 511) [615]. Nickel and palladium t-butoxide complexes decomposed to epoxides via oxometallacycles (equation 512) [616]. Long chain epoxides were synthesized by copper catalyzed co-oxidation of olefins and aldehydes [617]. The  $\text{Ru}^{\text{IV}}\text{O}/\text{Ru}^{\text{II}}\text{OH}_2$  couple catalytically epoxidized olefins [618].

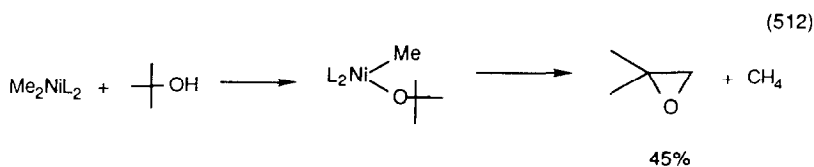
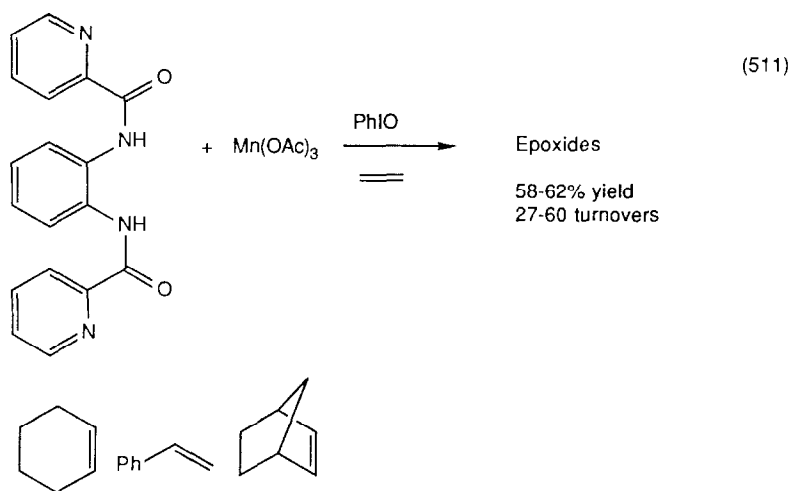

Monocyclic  $\beta$ -lactams were produced in the reaction of copper acetylides with nitrones (equation 513) [619]. Iron ketenimine complexes underwent oxidative decomposition to  $\beta$ -lactams (equation 514) [620]. Iron carbonyl anions attacked keteneimines to produce metallazetidines (equation 515) [621]. Bicyclic  $\beta$ -lactams were prepared using palladium(O) catalysis to form the non-lactam ring (equation 516) [622], (equation 517) [623]. Palladium on carbon debenzylated cepham sulfones in the presence of hydrogen but led to alkoxylation in the absence of hydrogen (equation 518) [624].

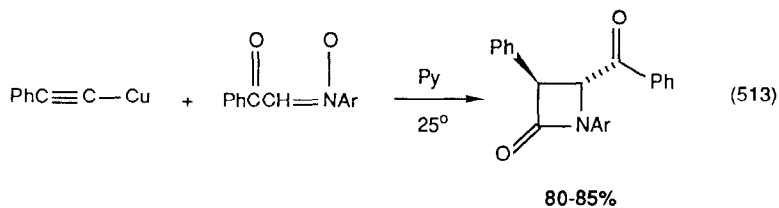



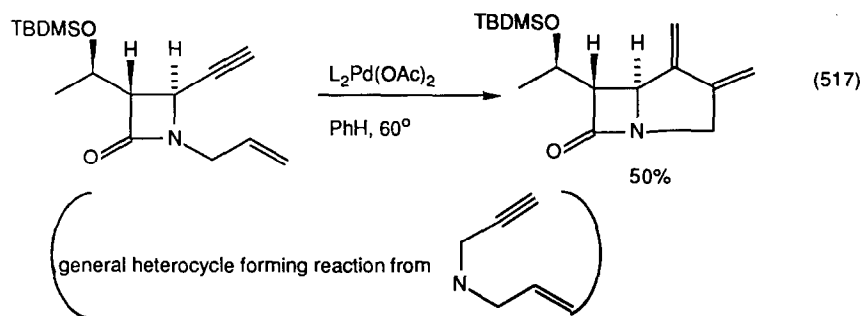
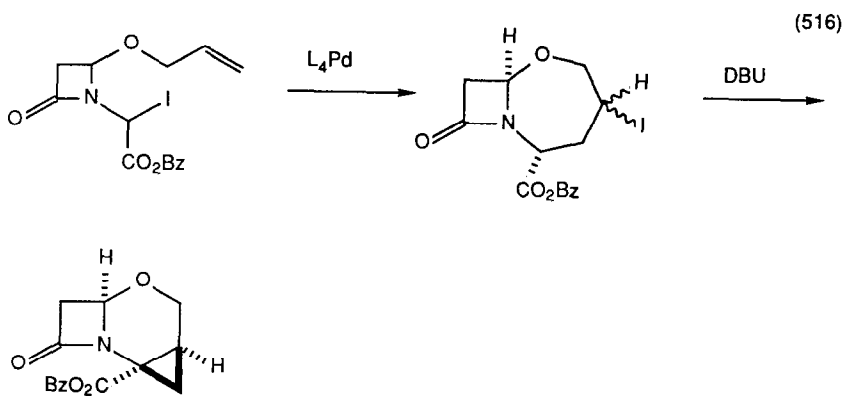
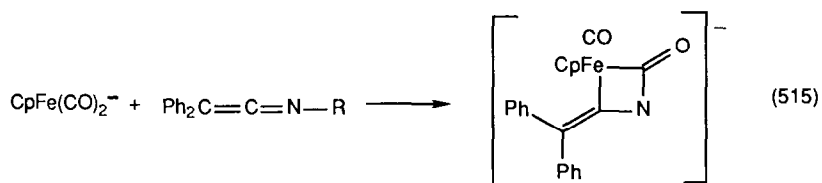
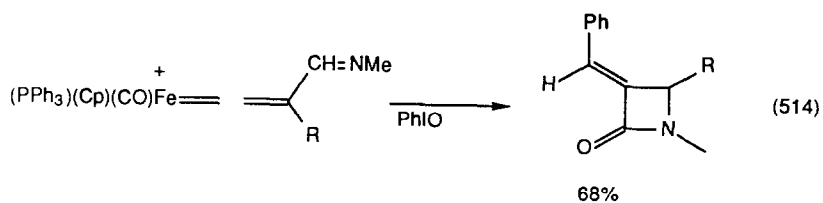

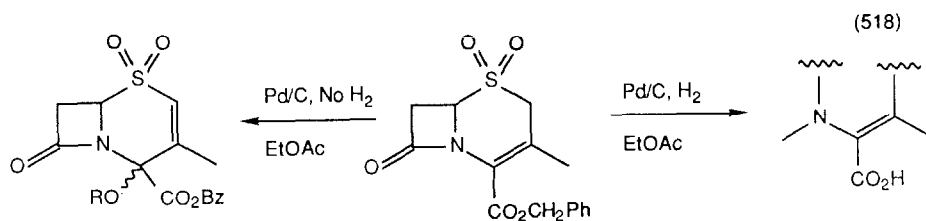

Chromium chloride cyclized *o*-carboxybenzyl halides to benzofurans (equation 519) [625]. Cobalt(I) salen complexes cyclized ortho iodo allylphenyl ethers to furans (equation 520) pyrans (equation 521) or indoles (equation 522) [626]. Tetrahydrofurans were also made by cobaloxime-catalyzed electrochemical reductions (equation 523) [627]. The adduct between crotyl bromide and *o*-protected glyceraldehyde in the presence of chromium(II) salts was converted to (+)-multistriatin [628]. Aminocarbene complexes of iron reacted with alkynes to give  $\alpha$ -aminofurans in fair yield (equation 524) [629]. Ynones were cyclized to furans by palladium(O) complexes (equation 525) [630]. Benzofurans were prepared by the palladium(II) catalyzed reaction of ortho halophenols with terminal alkynes (equation 526) [631]. Palladium(O) catalyzed the cycloaddition of  $\alpha$ -methylene lactones to aldehydes to give tetrahydrofurans (equation 527) [632]. Molybdenum(VI) catalyzed the reaction of enol ethers with conjugated ketones to give pyrans (equation 528) [633]. Cationic iron dienyne complexes underwent an intramolecular attack by remote alcohols to produce oxygen heterocycles (equation 529) [634]. Ortho dihydroxy benzene condensed with the chromium tricarbonyl complex of *o*-dichlorobenzene to give the expected six-membered heterocycle (equation 530) [635].

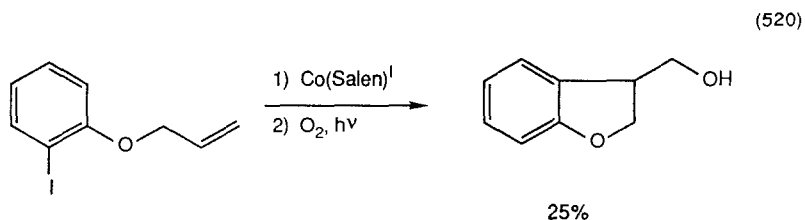
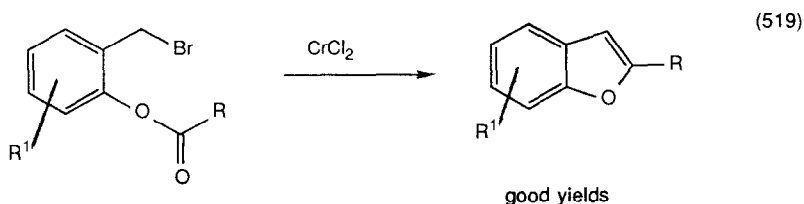

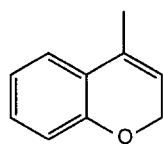
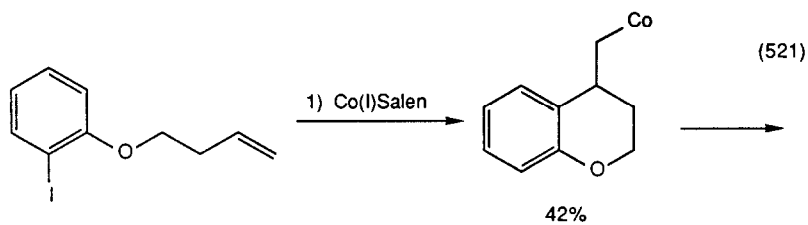

No yield

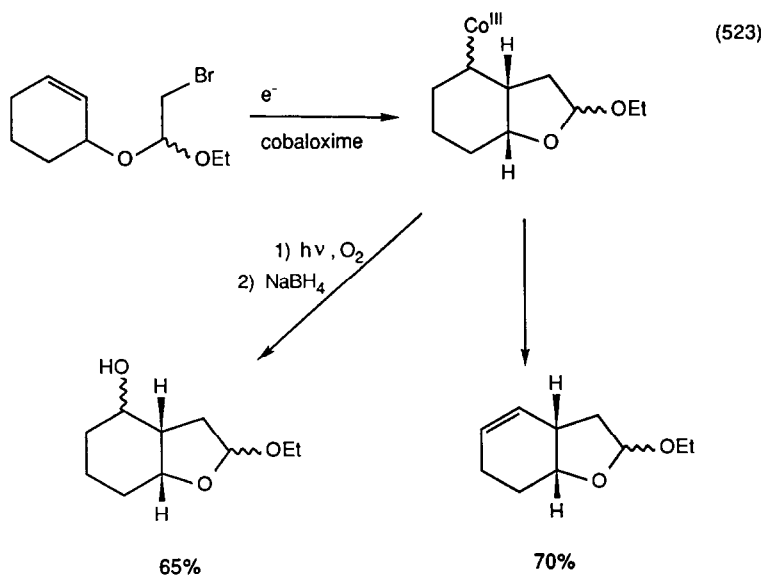
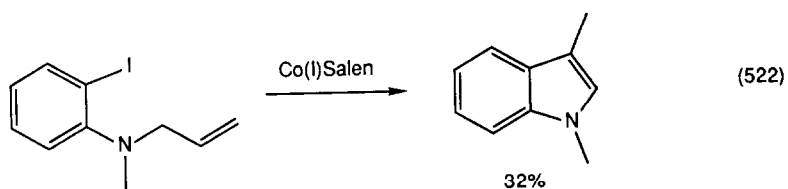

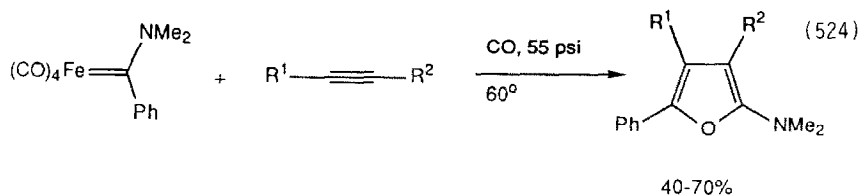

$\text{R}^1 = \text{Me, Et, CO}_2\text{tBu, tBuO, Ph, nPr, CO}_2\text{Me}$

$\text{R}^2 = \text{Me, Et, CO}_2\text{tBu, tBuO, H, Me}$

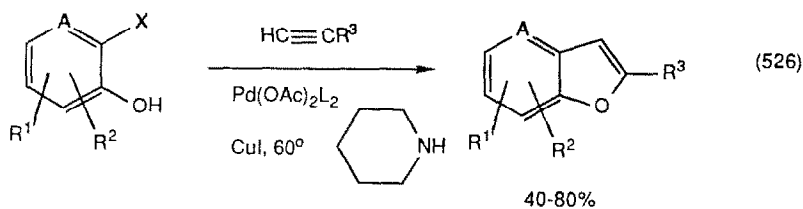
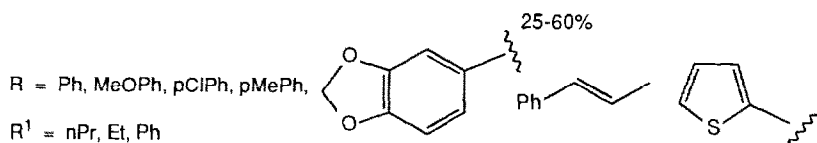
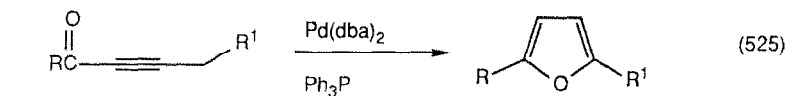

$\text{A} = \text{CH, N}$

$\text{X} = \text{I, Br}$

$\text{R}^1 = \text{H, 2Me, CHO}$

$\text{R}^2 = \text{H, 3OMe}$

$\text{R}^3 = \text{nBu, Ph, CO}_2\text{Me, CH}(\text{OEt})_2, \text{CO}_2\text{Et, steroid, Ph}$

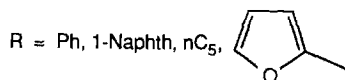
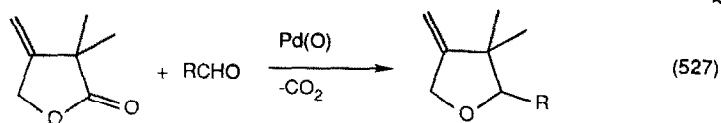

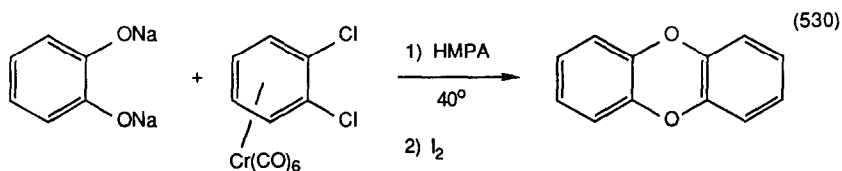
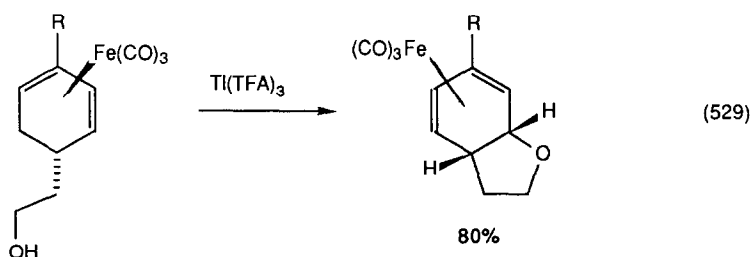
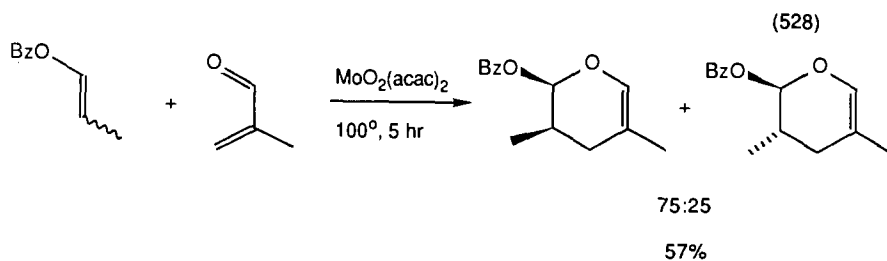

Manganese bromocarbonyl combined alkynes with methyl iodide and carbon monoxide to produce lactones (equation 531) [636]. Diols were oxidatively cyclized to lactones by ruthenium complexes (equations 532 and 533) [637], or rhodium complexes (equation 534) [638]. Manganese(III) acetate cyclized olefins with malonic acids to give lactones (equation 535) [639]. Ortho-homoallyl phenols were cyclized to benzopyrans by palladium(II) salts (equation 536) [640].

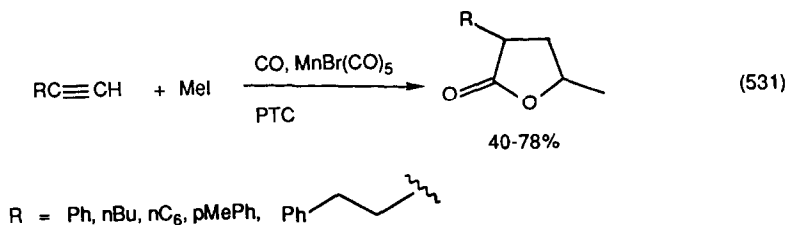

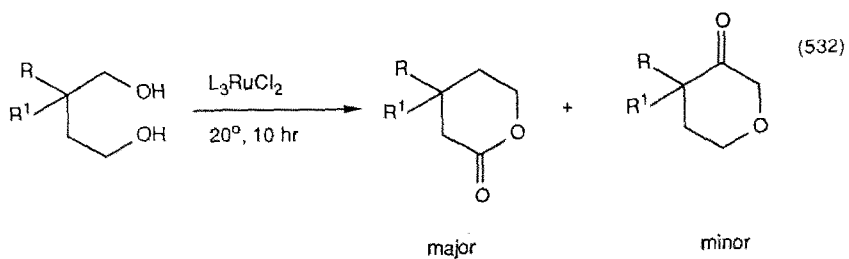

R = Me, *i*Pr, Ph, MeO, BuO, BzO, MeOCH<sub>2</sub>O

60-99%

R<sup>1</sup> = H, Me

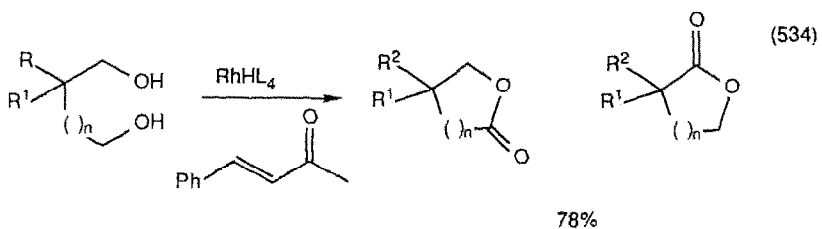
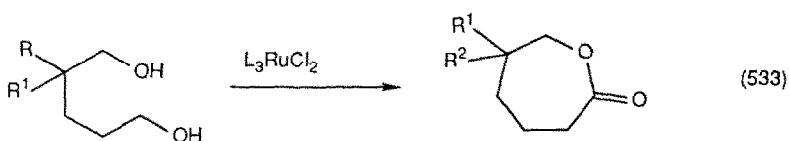

n = 1, 2

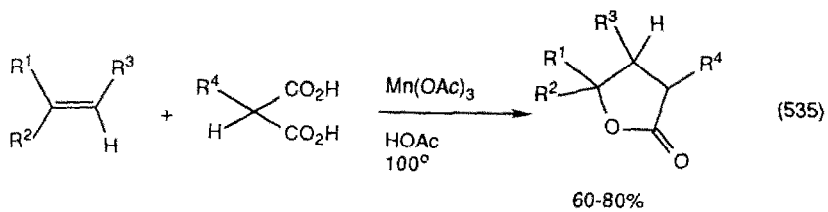

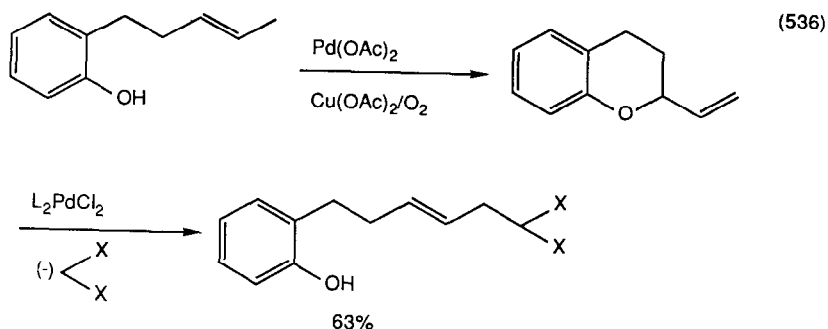

Dicobalt octacarbonyl converted benzyl bromide and diphenyl acetylene to a hydroxybutenolide (equation 537) [641]. The syntheses of  $\alpha$ -methylene- $\gamma$ -butyrolactones has been reviewed (40 references) [642]. Reduction of  $\beta$ -carboethoxyallyl bromides with chromium(II) in the presence of aldehydes produced  $\alpha$ -methylene lactones (equation 538) [643]. Acetylenic carboxylates (equation 539) [644] and carbonates (equations 540 and 541) [645] cyclized to lactones in the presence of palladium(II) salts. Diols were converted to carbamates (equation 542) and aminoalcohols to carbamates (equation 543) by palladium(II) salts in the presence of carbon monoxide [646]. Diphenylcyclopropenium cations were converted to  $\alpha$ -pyrones via their cobalt complexes (equation 544) [647].

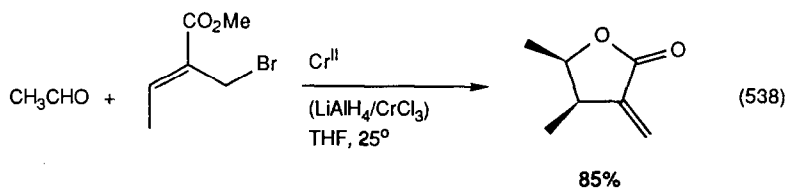
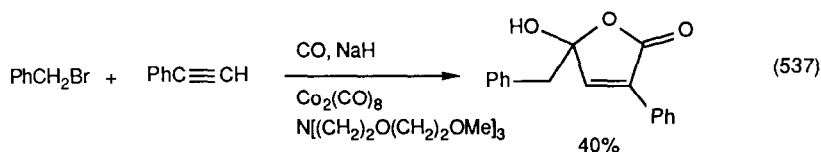

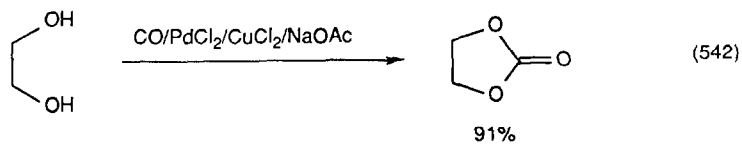
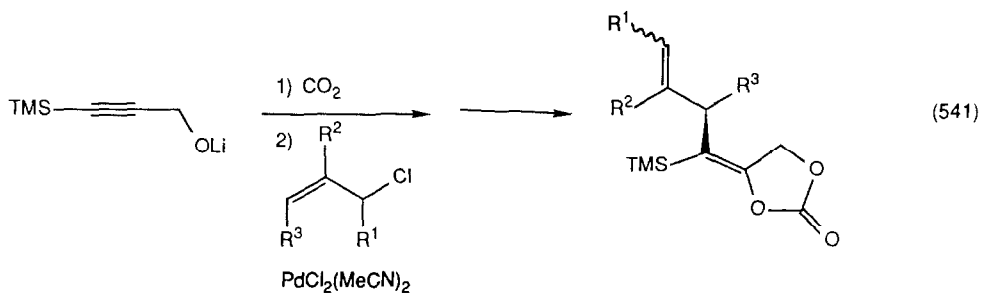
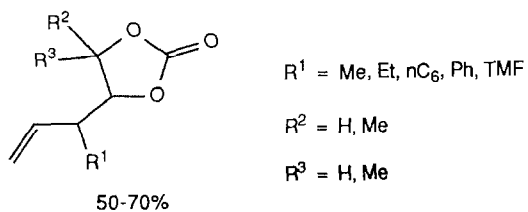
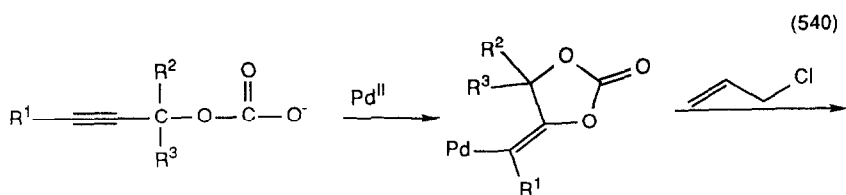
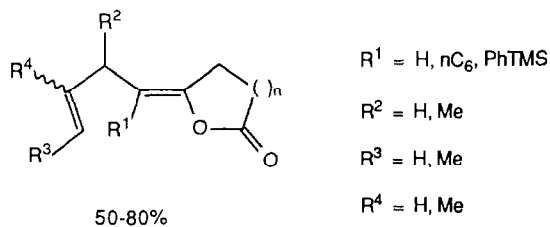
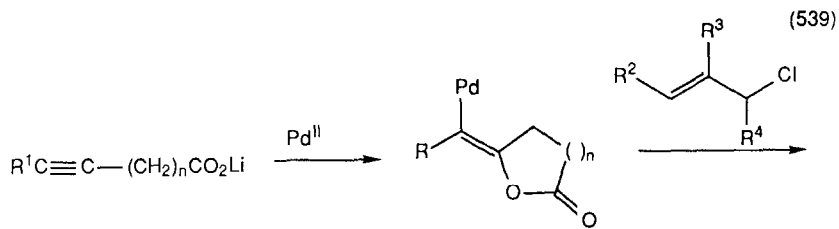



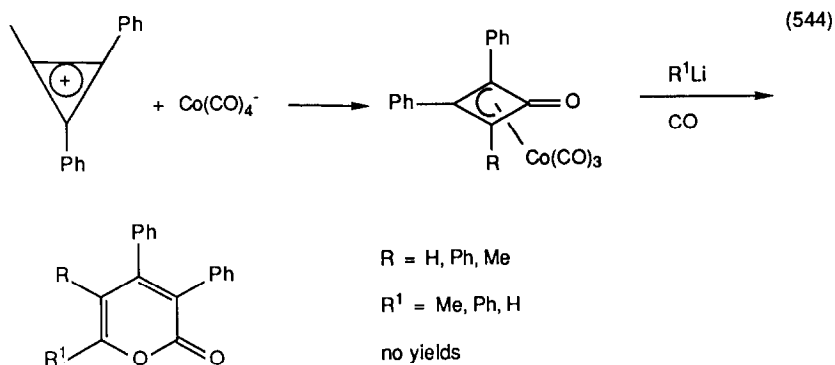
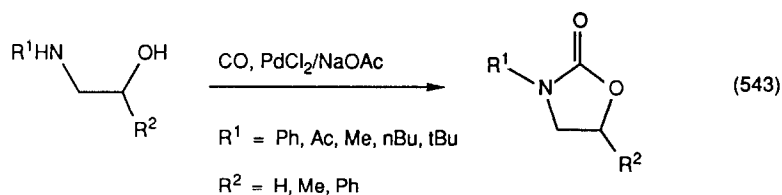

Tetrahydropyrroles were synthesized by the reductive amination of 1,2-dialdehydes in the presence of  $\text{HFe(CO)}_4^-$  (equation 545) [648], and by the palladium(II) catalyzed intramolecular amination of allenes (equation 546) [649] and olefins (equation 547) [650]. Nickel(0) or palladium(0) catalyzed the cyclization of alkynes with trimethylsilyl cyanide to give pyrroles (equation 548) [651]. Copper(II) chloride promoted the reaction of aroylazoalkenoates with  $\beta$ -ketoamides to give pyrroles (equation 549) [652].

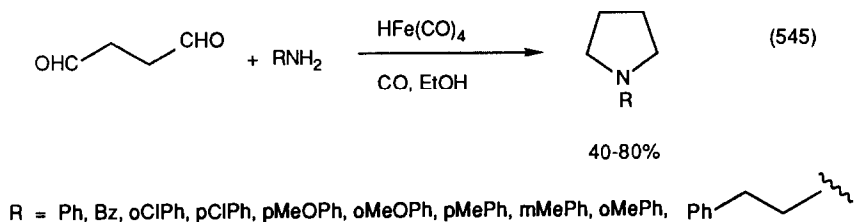

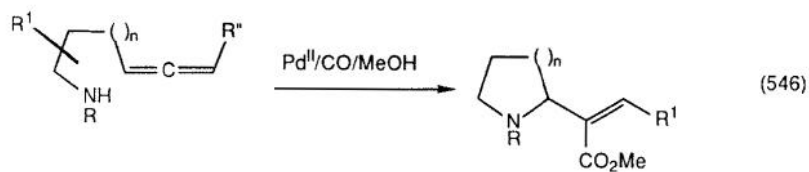

R = PhCH<sub>2</sub>, Ts, CO<sub>2</sub>Me

40-80%

R<sup>1</sup> = H, α-CO<sub>2</sub>Me

R<sup>2</sup> = H, nC<sub>5</sub>, Me

n = 1, 2

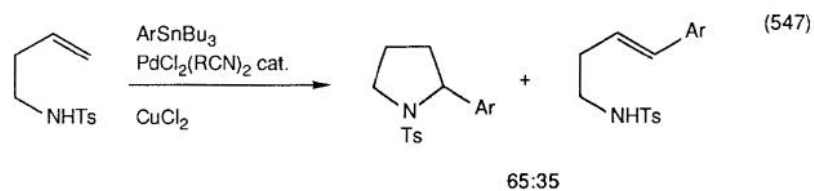

65:35

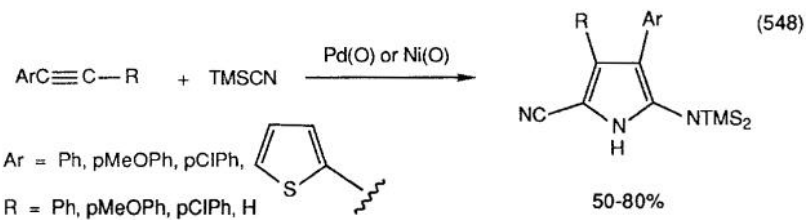
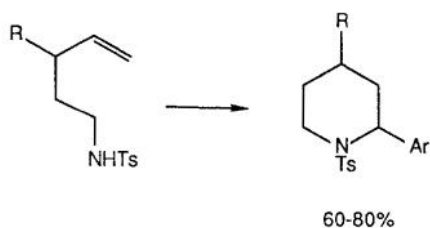

Ar = Ph, pMeOPh, pClPh,

R = Ph, pMeOPh, pClPh, H

50-80%

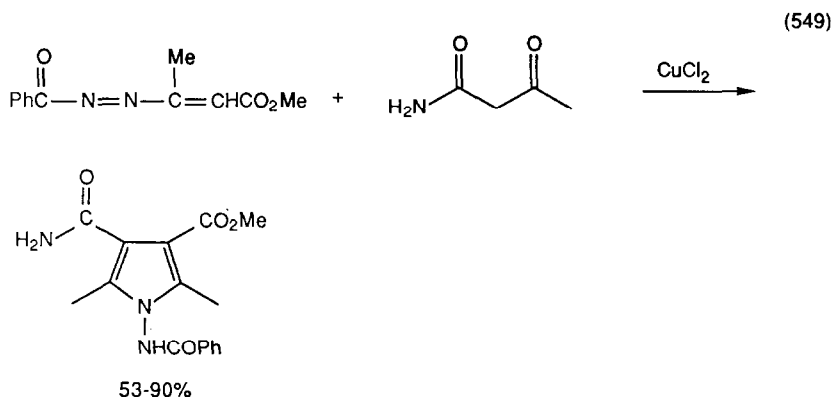

Nickel(O) cyclized isocyanates and olefins to give unsaturated lactams (equation 550) [653]. Palladium(O) cyclized  $\omega$ -olefin amidoyl chlorides to lactams (equation 551) [654]. Ruthenium nitrene complexes combined with alkynes to give lactams (equation 552) [655]. Ortho haloanilines combined with proline esters in the presence of carbon monoxide to give bislactams (equation 553) [656]. Polycyclic lactams were prepared by palladium-catalyzed oxidative addition/insertion processes on appropriate substrates (equation 554) [657].

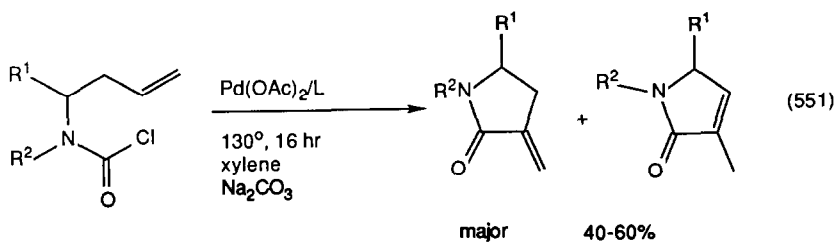
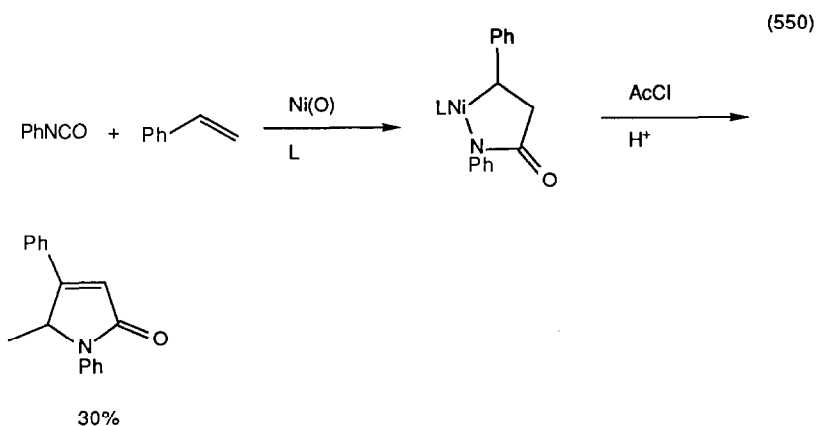

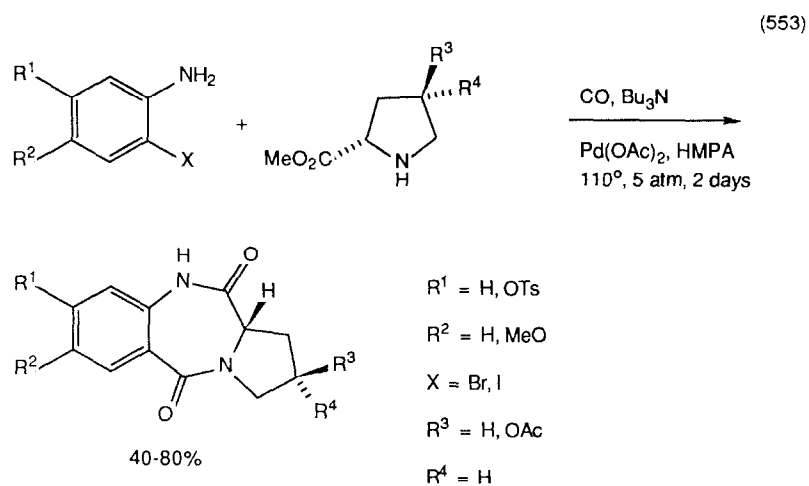
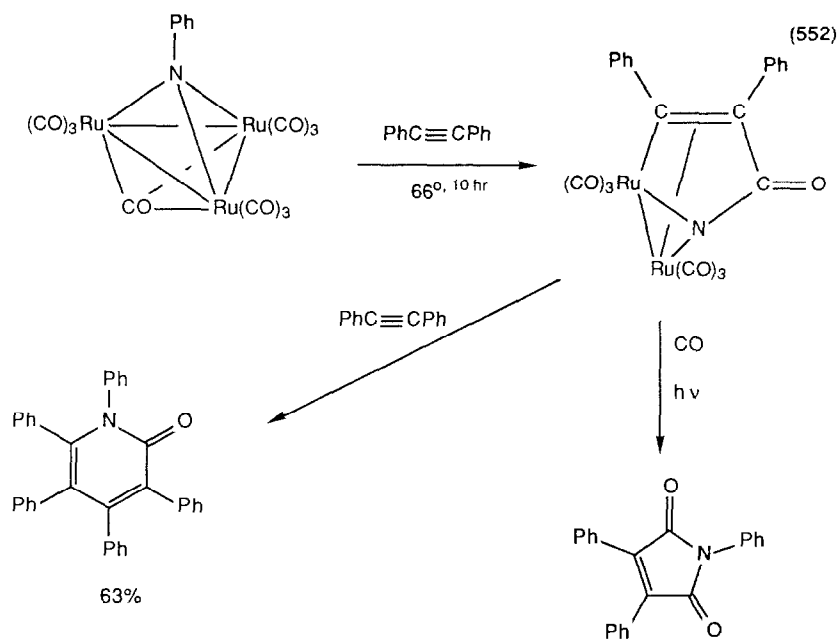

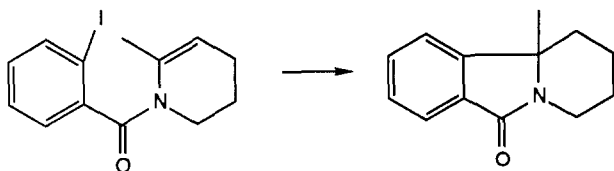
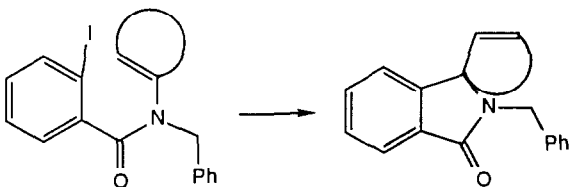
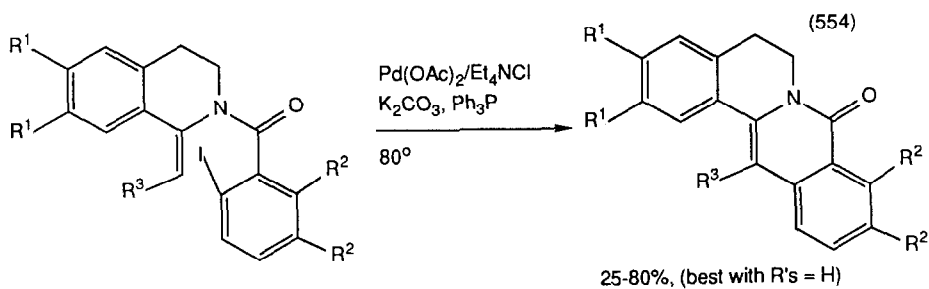

Organocobalt compounds in the synthesis of pyridines has been reviewed [658]. Cobalt(II)-zeolite catalysts converted phenyl acetylene and acetonitrile to pyridines (equation 555) [659], as did cobalt vapor (equation 556) [660]. Dienes and nitriles combined to give pyridines in the presence of  $\text{CpCo(CO)}_2$  (equation 557) [661].

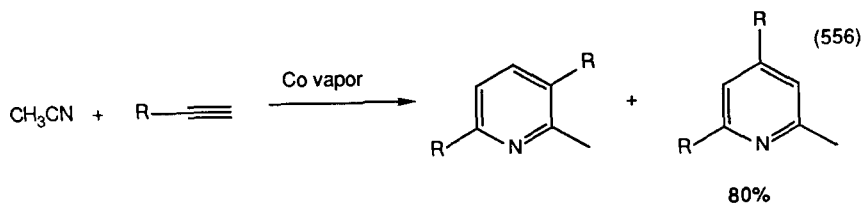
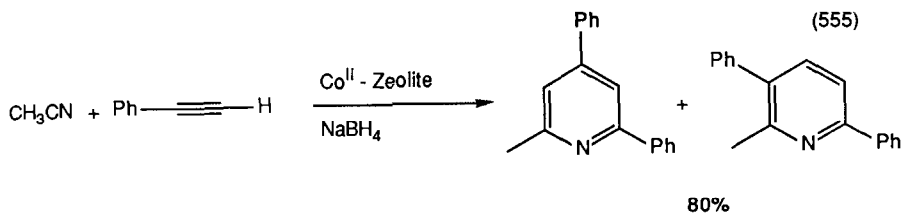

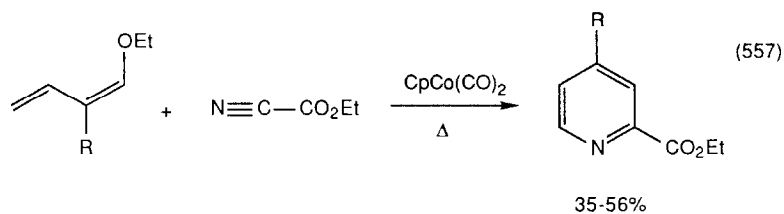

R = Me, Et, nPr, iPr, nBu, nC<sub>5</sub>

Palladium catalysis in the synthesis of indoloquinones has been reviewed (17 references) [662]. Palladium(O) catalysts cyclized N-vinyl-o-bromoanilines to indoles (equation 558) [663], as did nickel(O) complexes (equation 559) [664], (equation 560) [665]. Aniline (equation 561) [666] and ortho bromoaniline (equation 562) condensed with alkynes in the presence of palladium(II) catalysts to give indoles.

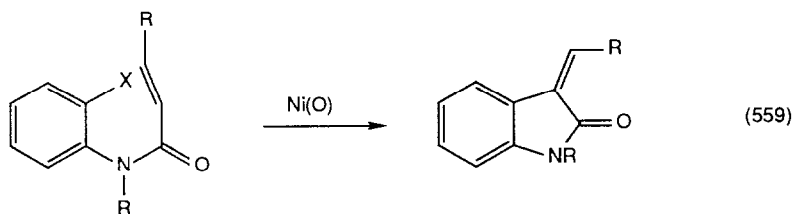
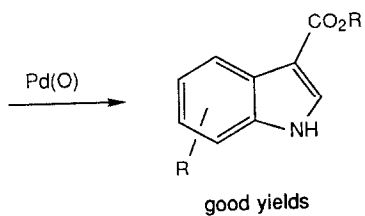
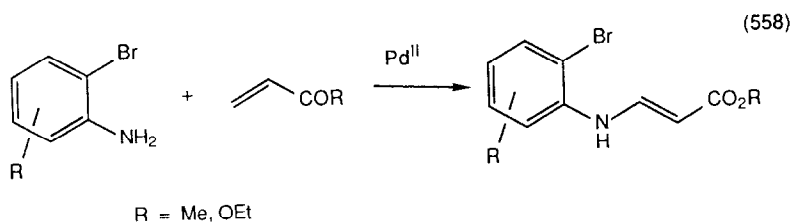

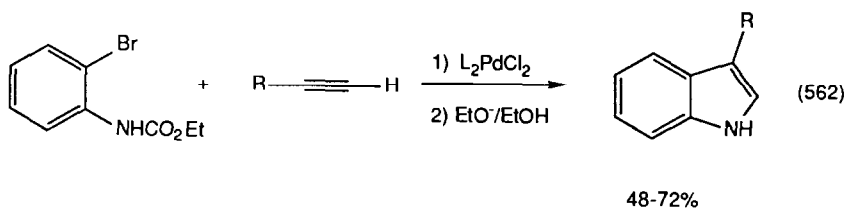
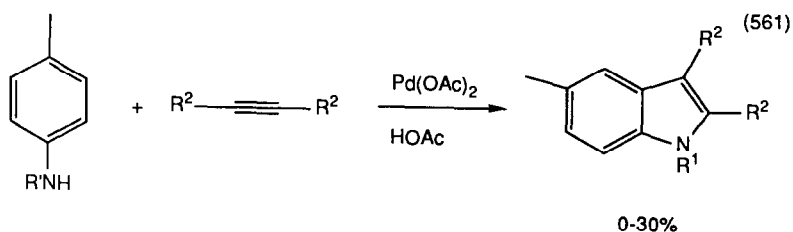
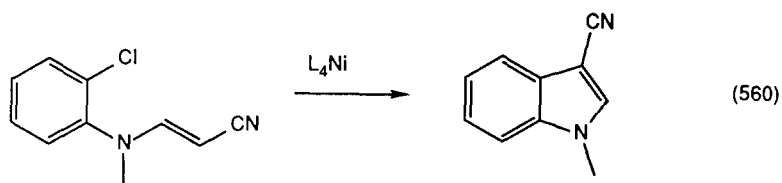

R = TMS, Bu, Ph

Anilines and 1,2-diols were oxidatively cyclized to indoles in the presence of ruthenium catalysts (equation 563) [668], (equation 564) [669]. Ortho nitrostyrenes cyclized to indoles in the presence of iron, rhodium and ruthenium carbonyls (equation 565) [670], (equation 566) [671].

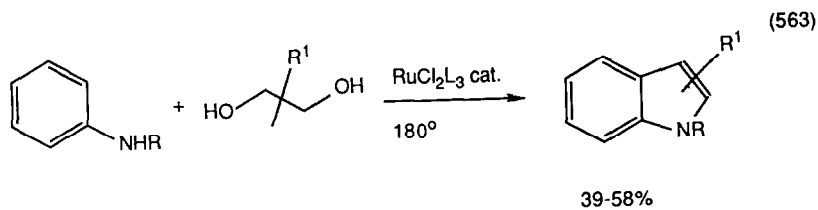

R = H, Me, Et

R<sup>1</sup> = H, 1,2-Me<sub>2</sub>

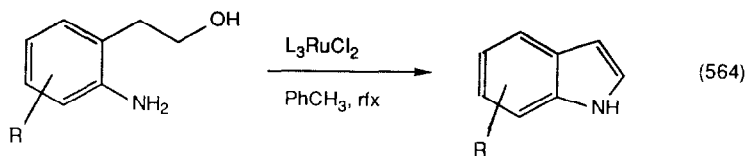

R = H	100%
6-Me	80%
4-Cl	92%
4-Br	73%

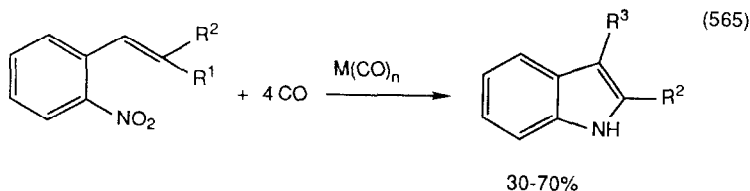

R<sup>1</sup> = H, Me

R<sup>2</sup> = H, Me, CO<sub>2</sub>Me, Ph, 2-Py

R<sup>3</sup> = H, Me, Ph

Mn(CO)<sub>n</sub> = Fe(CO)<sub>5</sub>

Ru<sub>3</sub>(CO)<sub>12</sub>

Rh<sub>6</sub>(CO)<sub>10</sub>

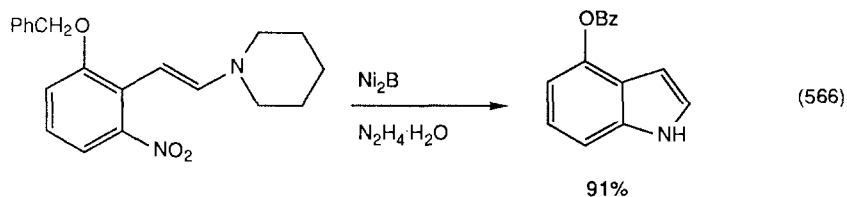

Isonitriles reacted with Fisher carbene complexes to give unusual heterocycles (equation 567), (equation 568) [672], (equation 569) [673]. Ruthenium hydride-phosphine complexes transformed *o*-mesityl isocyanate to 7-methyl indole (equation 570) [674]. *N*-Allyl indoles condensed with nitriles in a "Ritter"-like reaction in the presence of highly electrophilic palladium(II) species (equation 571) [675]. Pyrrolo[3,2,1-*j,k*]carbazoles were prepared by the nickel(O) mediated ring contraction of pyrrolo[3,2,1-*k,l*]phenothiazines [676].



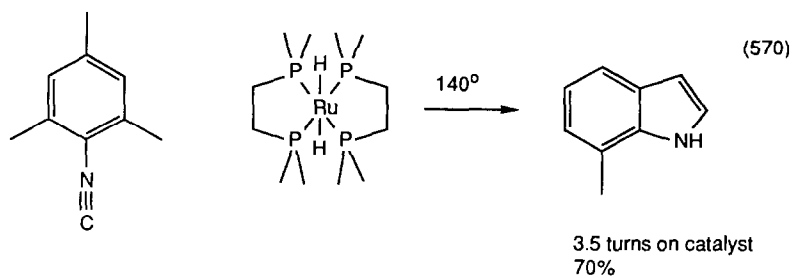
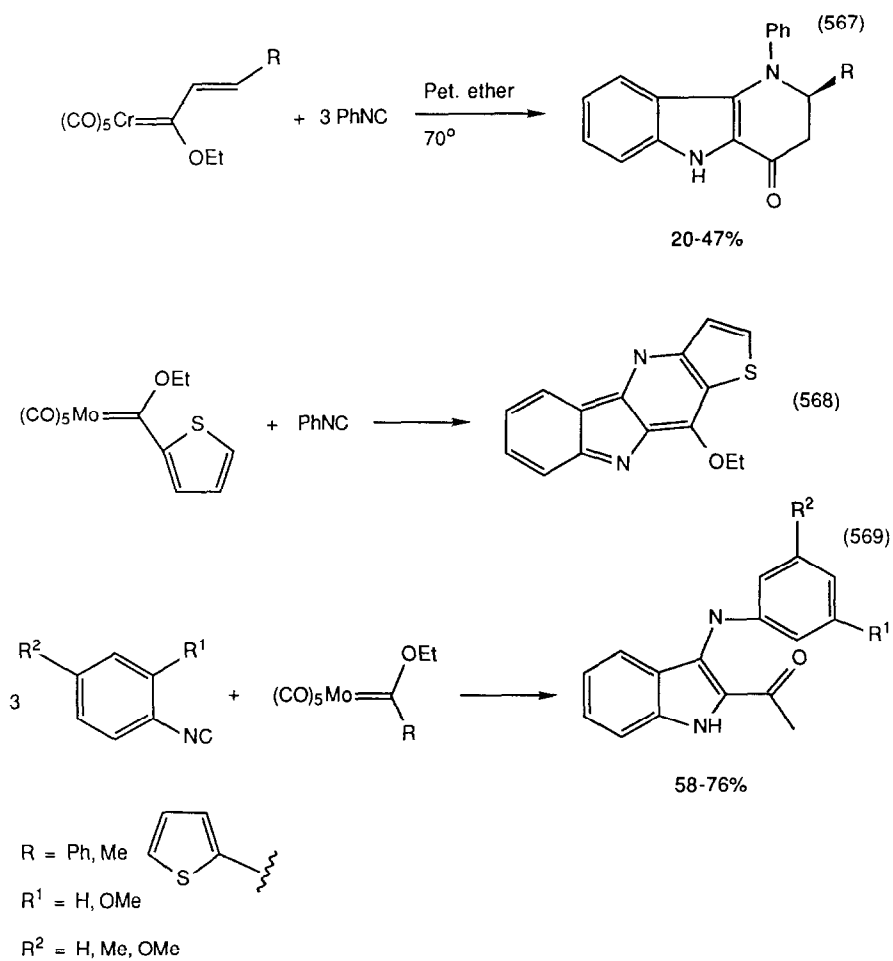

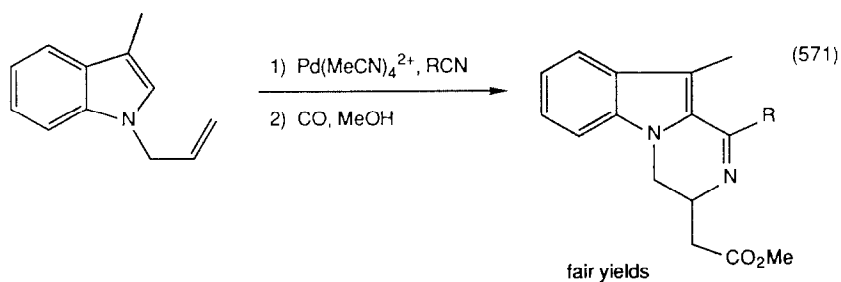

Fisher carbenes, isocyanides and isocyanates combined to produce cyclic acylureas (equation 572) [677]. Rhodium(II) catalyzed decomposition of diazomalonates in the presence of nitriles produced oxazoles (equation 573) [678]. Benzoxazoles were prepared by the copper catalyzed condensation of *o*-hydroxy aniline with aldehydes [679]. Aldehydes reacted with gold isonitrile complexes to produce oxazoles (equation 574) [680].

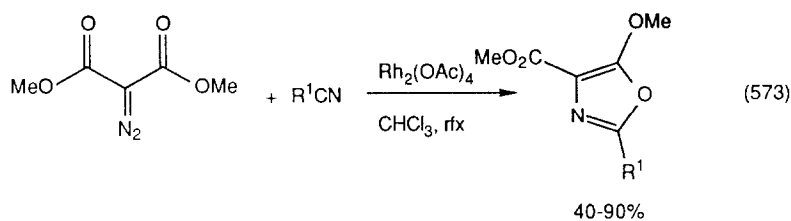
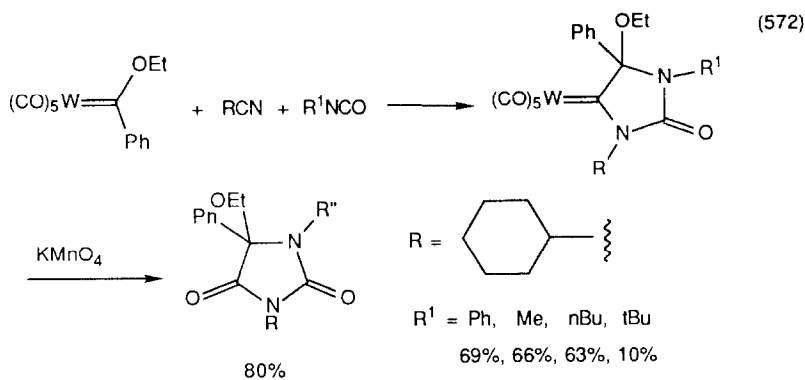

R = Ph, 4ClPh, 4MePh, 4MeOPh, 4NO<sub>2</sub>Ph (0%)

3ClPh, PhCH<sub>2</sub>, Me, nPr, nC<sub>8</sub>, iPr, tBu

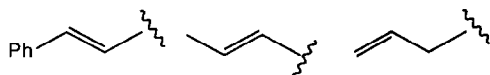

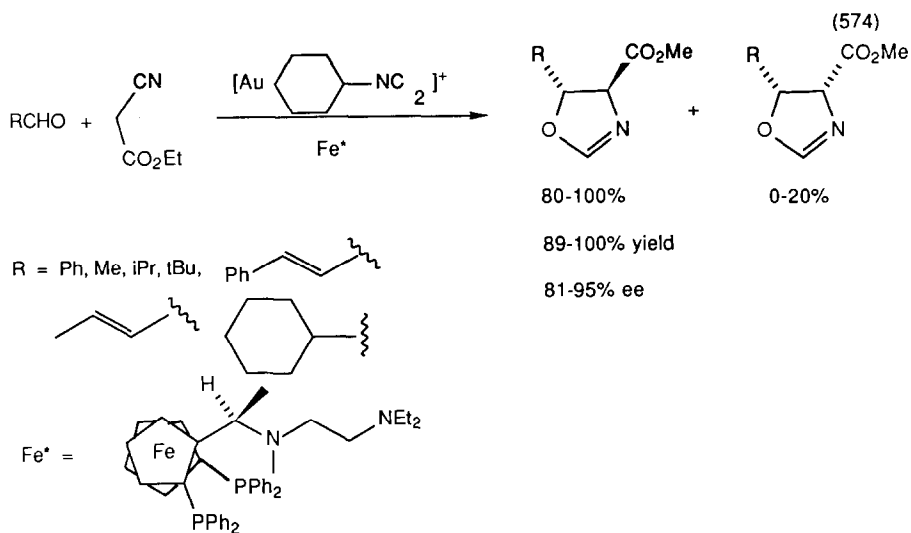

Thiocarbamates condensed with *o*-iodoanilines in the presence of reduced nickel salts to produce benzothiazoles (equation 575) [681]. Quinazolines were prepared from palladium catalyzed carbonylation of *o*-iodoaniline-lactam mixtures [682]. Oxepins were made by the palladium-catalyzed decomposition of 4-diazomethyl-4*H*-pyrans (equation 576) [683]. More complex heterocycles were also prepared using palladium catalyzed processes (equations 577 and 578) [684].

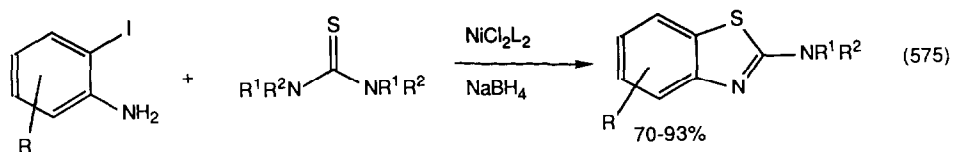

R = H, 5M, 5Cl, 5F

R<sup>1</sup> = H, Me, nBu, Ph

R<sup>2</sup> = H, Me

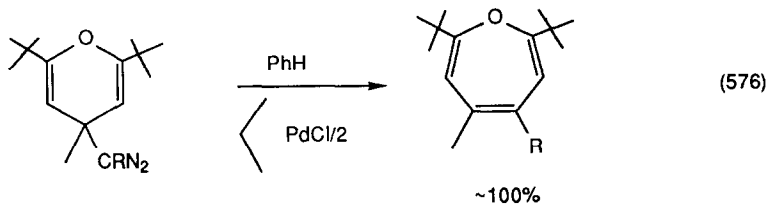

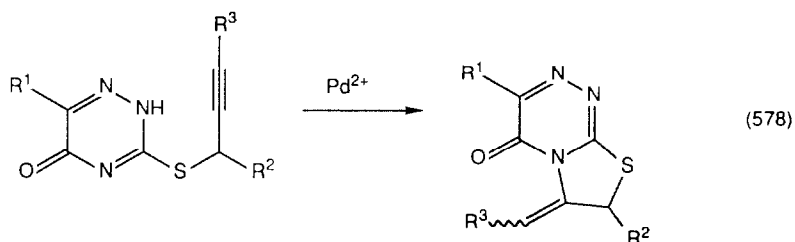
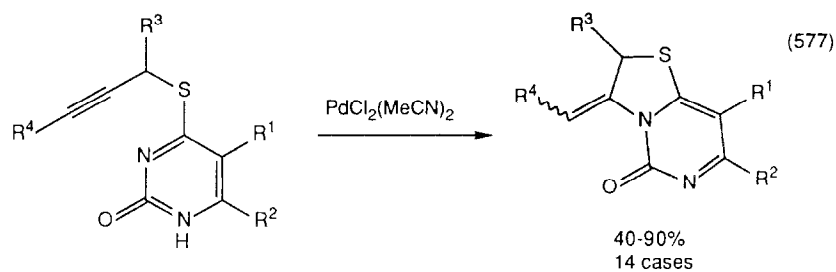

#### F. Alkenes, Alkanes

Reduced nickel species in the presence of DBU, converted primary halides to olefins in an elimination reaction (equation 579). Palladium(O) complexes catalyzed the elimination of amines from allyl amines to give dienes (equation 580) [686]. Zirconium hydrazides olefinated ketones (equation 581) [687]. Reduction of cobalt carbonate with triethyl aluminum produced a black powder which aromatized tetralin [688].

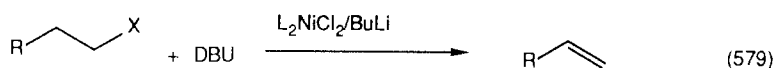

R = PhCH<sub>2</sub>O-(CH<sub>2</sub>)<sub>4</sub> Br 56%  
Cl 68%  
I 0%

THPO(CH<sub>2</sub>)<sub>6</sub>Br, 12%; nC<sub>16</sub>Br, 77%;  
EtO<sub>2</sub>C(CH<sub>2</sub>)<sub>3</sub>Br, 77%; HO(CH<sub>2</sub>)<sub>11</sub>Br, 82%;

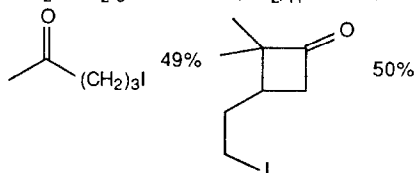

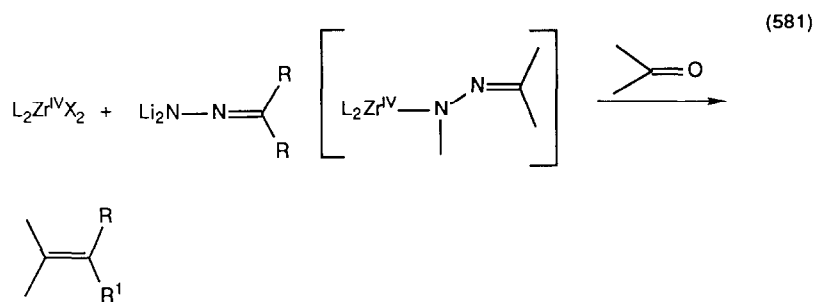
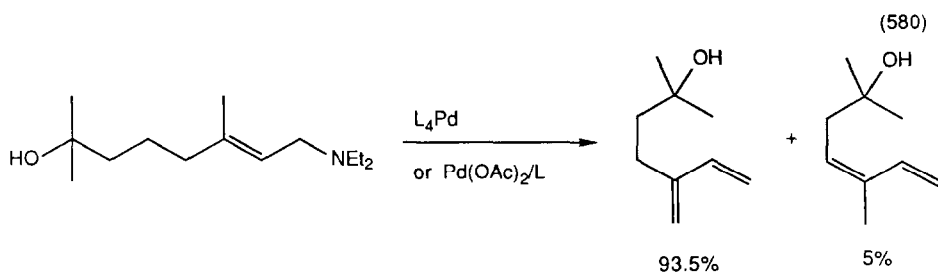

Palladium complexes catalyzed the reduction of a wide range of allylic systems to olefins (equation 582) [689], (equation 583) [690], (equation 584) [691], (equation 585) [692], (equation 586) [693]. Allyl alcohols were reduced to olefins in a multistep process involving cyclopentadienyliron chemistry (equation 587) [694]. Dienes were reduced to olefins by dicobalt octacarbonyl under phase transfer conditions (equation 588) [695]. Eneynes were converted to dienyl tin reagents by hydrosilylation/transmetalation (equation 589) [696].

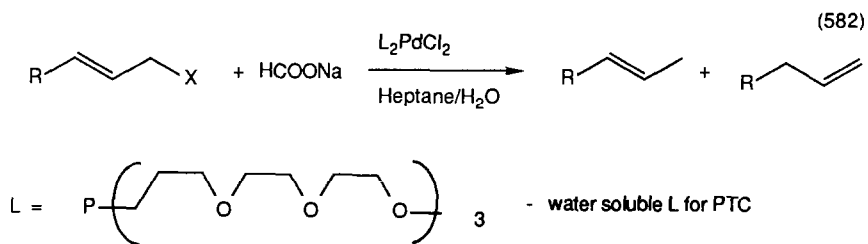

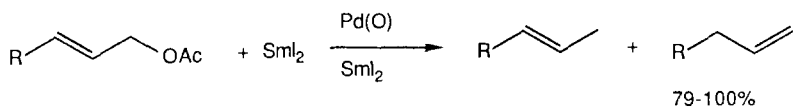
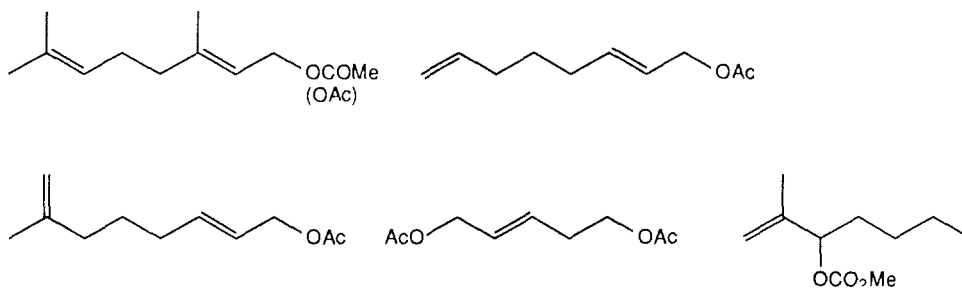
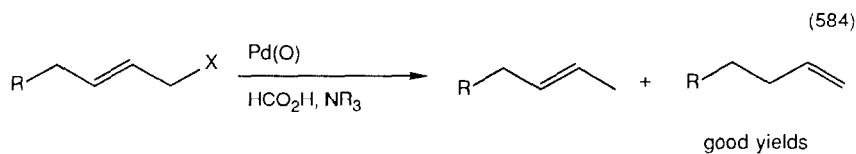
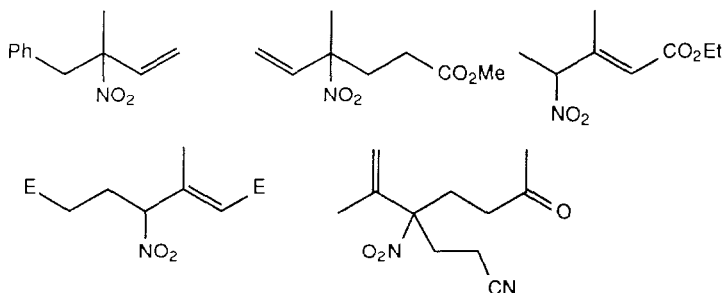
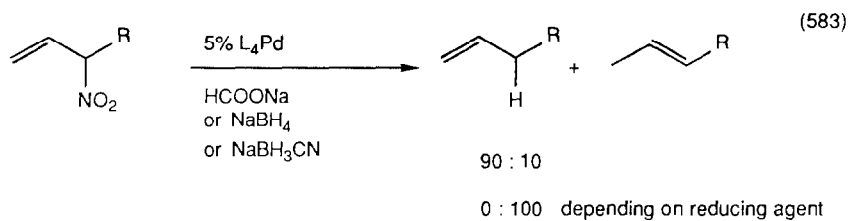

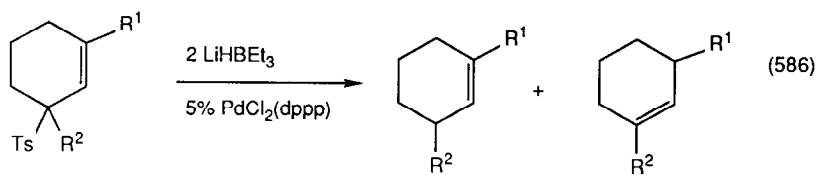

89-91%

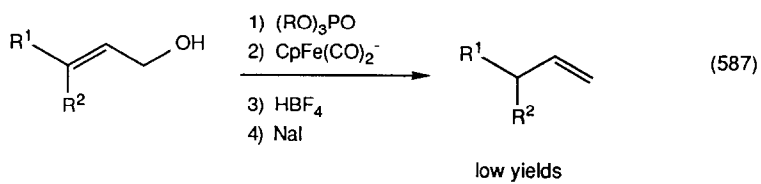
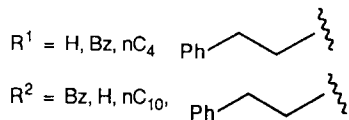

low yields

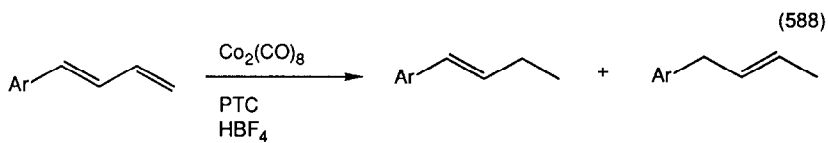

(588)

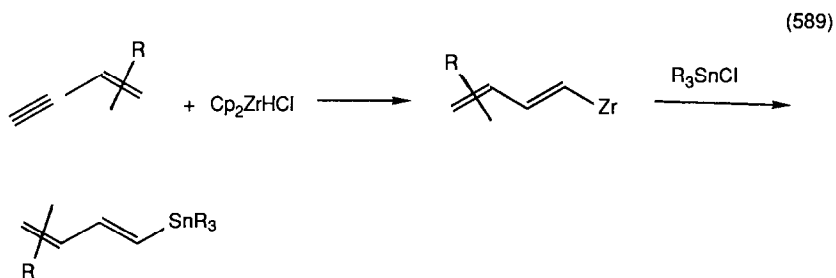

(589)

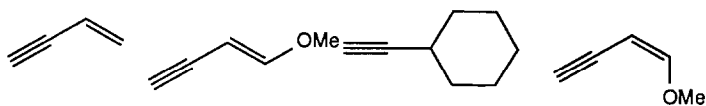

Episulfides were desulfurized to olefins by rhodium carbonyls (equation 590) [697]. Allyl carbamates were cleaved to olefins and amines by palladium(O) catalysts and tin hydrides (equation 591) [698]. 1,5-Dienes were oxidatively cyclized by palladium(II) salts in the presence of  $\text{MnO}_2$  (equation 592) [699].

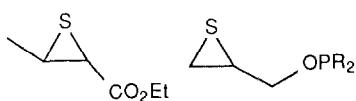
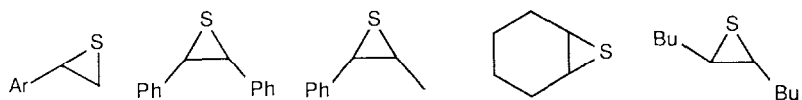
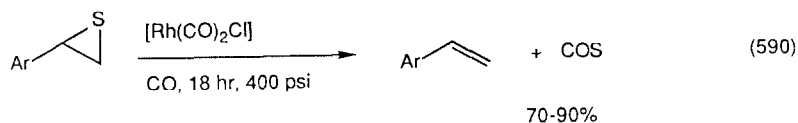

(591)

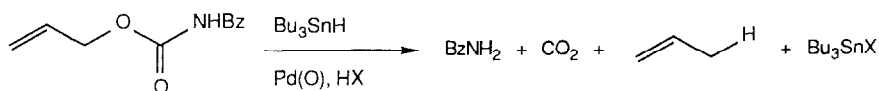

(good amino acid amine protecting group)

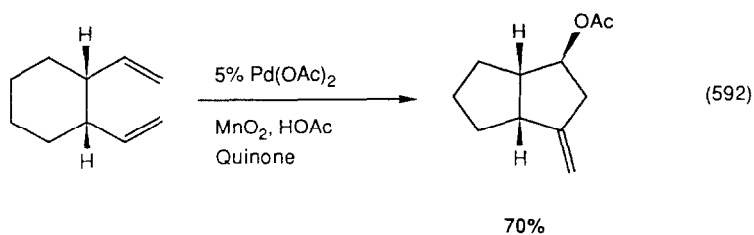



Aryl triflates (equation 593) [700][701] and halides (equation 594) [702][703] were reduced to hydrocarbons by formate salts in the presence of a palladium(O) catalyst. Benzyl chlorides were reduced to toluenes by sodium formate with palladium catalysts under phase transfer conditions in the presence of soluble phosphine ligands [704]. Aryl halides were reduced to arenes by nickel(II) chloride/zinc/HMPA mixtures with ultrasound irradiation [705]. Aryl, aliphatic and cycloaliphatic halides were reduced to hydrocarbons in the presence of CpTiCl<sub>2</sub> and isopropylmagnesium bromide [706].

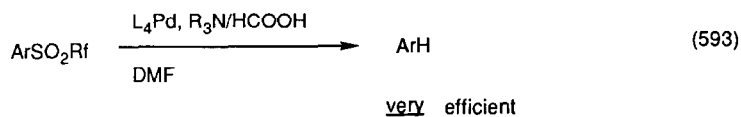

Ar = oClPh, mMeOPh, 2,6-Me<sub>2</sub>Ph, Ph, 2-Naphth, 3-NO<sub>2</sub>Ph, plus many more

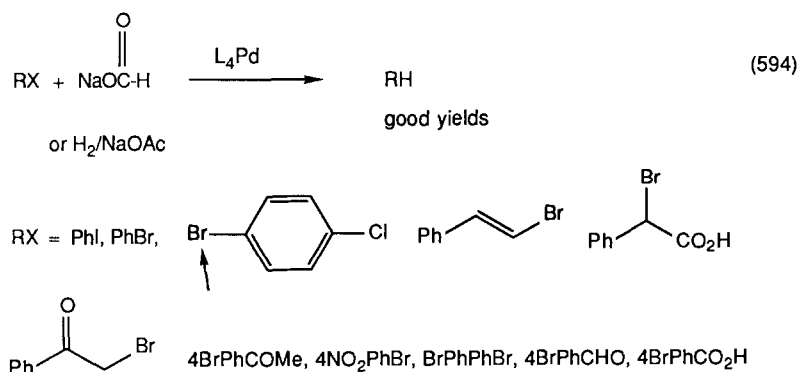

Aryl aldehydes and ketones were reduced to alkylarenes by hydrogen in the presence of rhodium(I)-cyclodextrin catalysts (equation 595) [707]. Trimethoxyacetophenone was ortho deuterated via manganese  $\sigma$ -aryl intermediates (equation 596) [708].

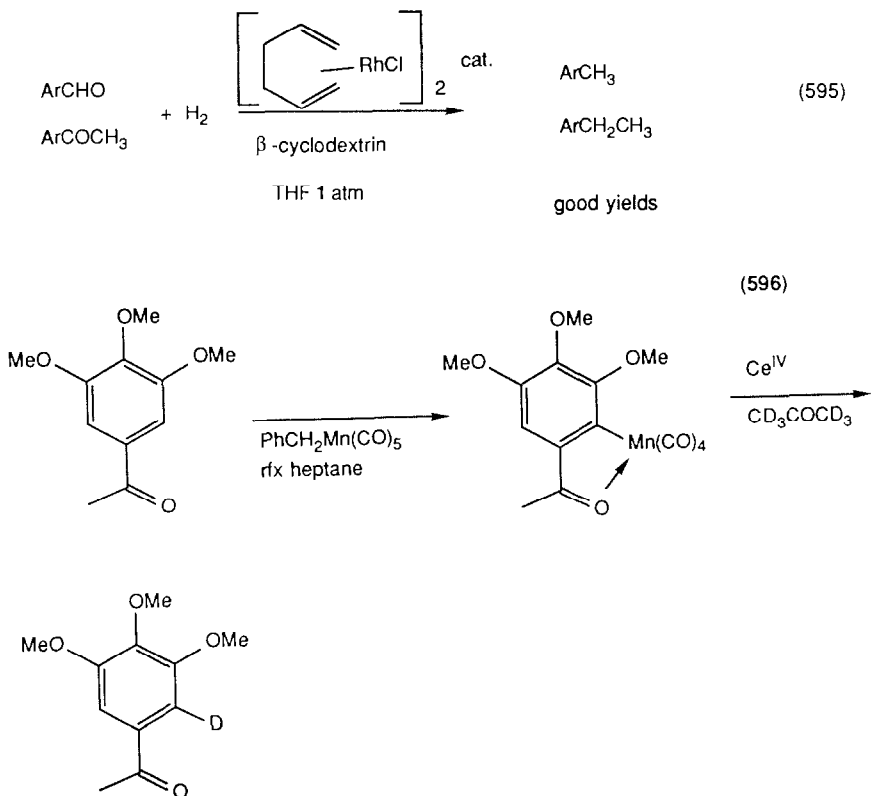

### G. Ketones, Aldehydes

Oxidation of lower olefins to ketones has been reviewed (76 references) [709]. Low temperature ethylene oxidation by modified Wacker catalysts was the subject of a dissertation [710]. Cyclopentene was cleanly oxidized to cyclopentanone by palladium(II) in the absence of benzoquinone and gave enol ether and ketal byproducts in the presence of quinone (equation 597) [711]. Palladium nitrile complexes oxidized terminal olefins predominately to the aldehyde (equation 598) [712]. Vinyl  $\beta$ -lactams were oxidized to keto  $\beta$ -lactams by palladium(II) (equation 599) [713]. The oxidation of  $\alpha$ -pinene to verbenone and verbenol was catalyzed by palladium(II) salts [714]. The terminal double bond of octasdienylamines was oxidized by palladium(II) chloride/benzoquinone (equation 600) [715]. Substituted  $\beta$ -methyl styrenes were oxidatively cleaved to benzaldehydes by a cobalt catalyst (equation 601) [716]. Manganese complexes catalyzed the oxidation of cyclohexene to cyclohexanone and cyclohexenol by hydrogen peroxide [717].

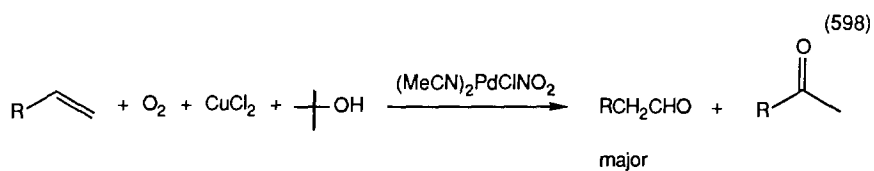
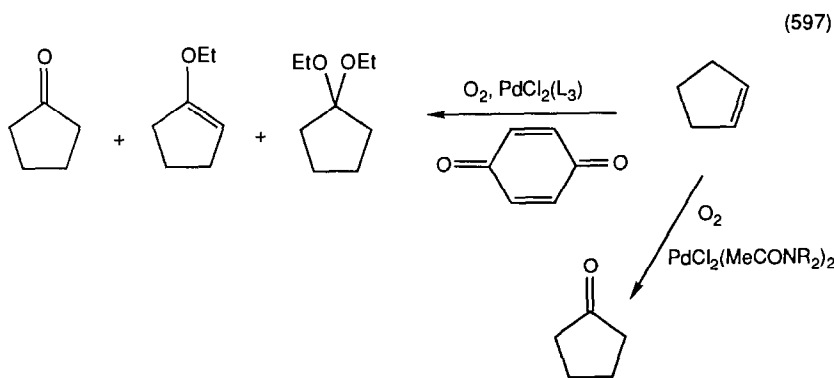

$\text{R} = n\text{C}_8, \text{Ph}$

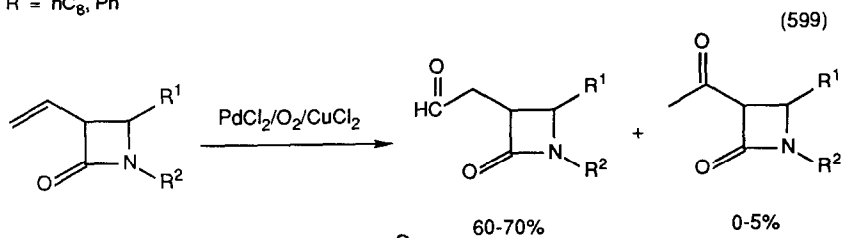

$\text{R}^1 = \text{Ph}, \text{pMeOPh}, \text{COPh}$

$\text{R}^2 = \text{Ph}, \text{pMeOPh}$

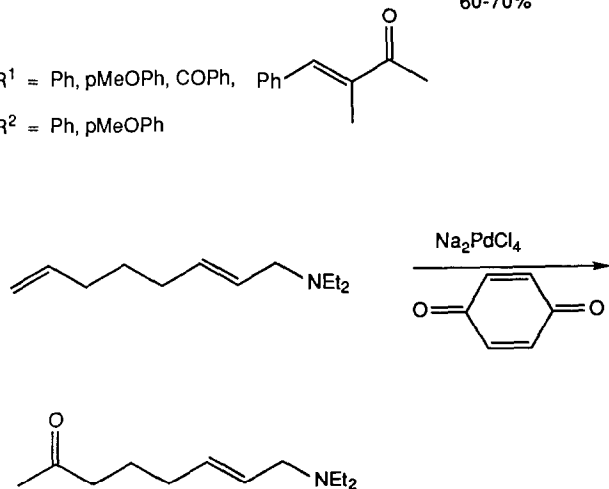

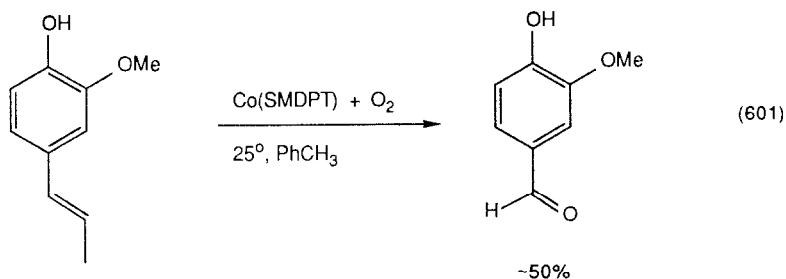

Secondary alcohols were oxidized to ketones by *t*-butyl hydroperoxide in the presence of molybdenum hexacarbonyls (equation 602) [718]. 1,3-Diols were selectively monooxidized. Bipyridyl chromium pentoxide was an efficient oxidant, taking alcohols to aldehydes and ketones, cleaving glycols, and oxidizing naphthalene to naphthoquinone [719]. Alcohols were electrochemically oxidized to carbonyls in a two phase system using the RuO<sub>2</sub>-RuO<sub>4</sub> couple to carry the redox [720]. Alkynes were converted to  $\alpha$ -dicarbonyls by molybdenum (equation 603) [721] and osmium (equation 604) [722] oxidizing systems. Benzylic positions were oxidized by *t*-butyl hydroperoxide/chromium(VI) systems (equation 605) [723].

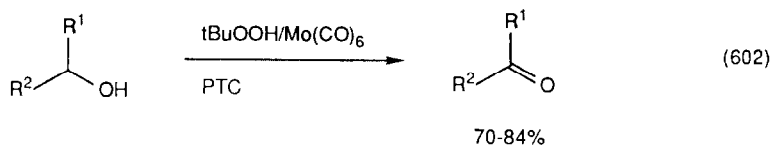

R<sup>1</sup> = *n*Bu, *n*C<sub>6</sub>

R<sup>2</sup> = H, Me (CH<sub>2</sub>)<sub>5</sub>

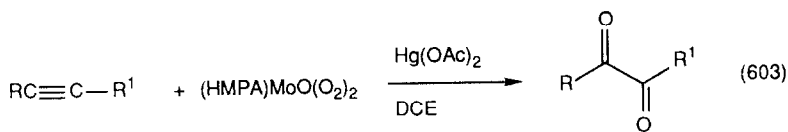

R = Ph, *n*C<sub>6</sub>, *n*Pr

R<sup>1</sup> = Ph, H, *n*C<sub>6</sub>

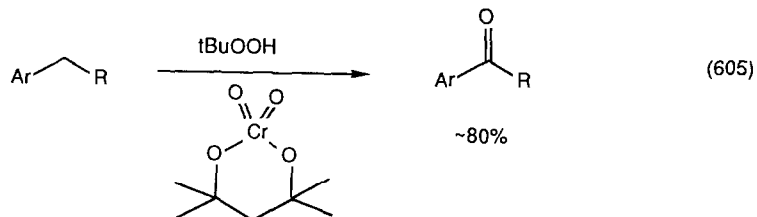
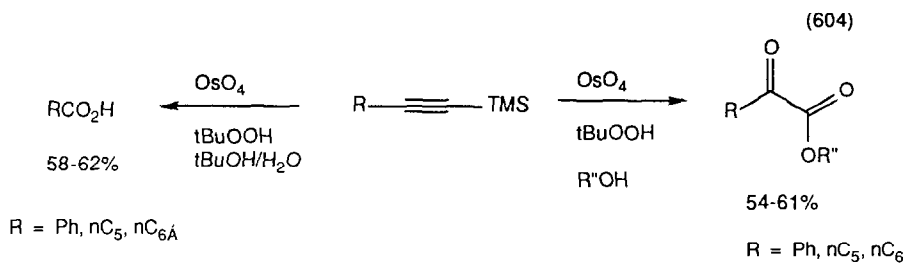

$\alpha,\beta$ -Unsaturated *N*-acetoxyoximes were converted to a number of products upon treatment with molybdenum hexacarbonyl (equation 606) [724]. Thioketones were converted to ketones by copper(I) chloride [725]. Dithioketals were converted to ketones by iron(III) amine compounds (equation 607) [726].

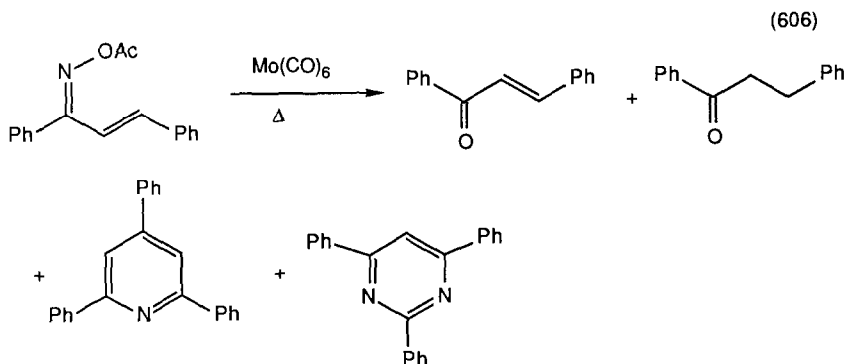

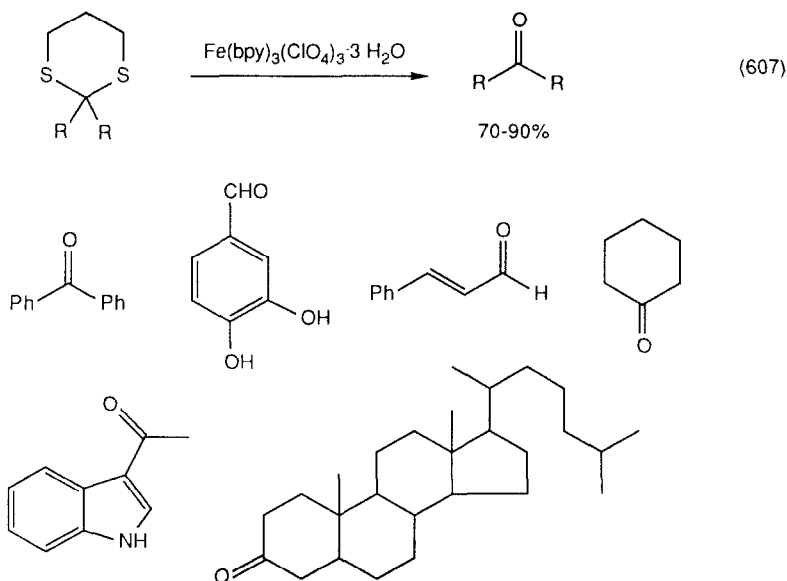

Methyl acetate was converted to acetaldehyde and acetic acid by cobalt(II) iodide/lithium iodide catalysts with high pressures of hydrogen and carbon monoxide [727]. Rhodium(I) complexes catalyzed the cyclization of appropriate olefinic aldehydes to cyclopentanones (equation 608) [728].  $\alpha$ -Chloroacid halides were converted to ketenes by manganese pentacarbonyl anion (equation 609) [729]. Diallylcarbonate was the reoxidant for the palladium(II) catalyzed oxidation of enol ethers to conjugated enones (equation 610) [730]. Diphenyl furans and pyrroles were opened to diketones by  $\text{MoO}_5\text{HMPA}$  (equation 611) [731].

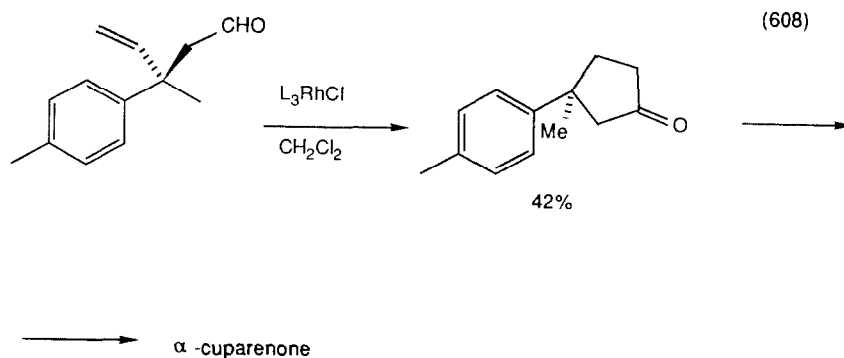

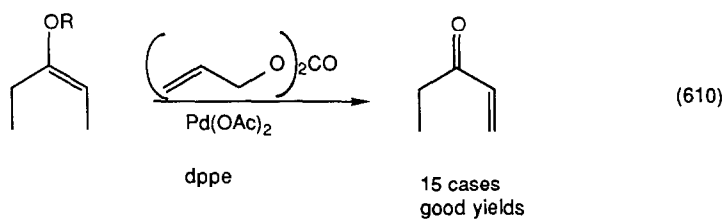
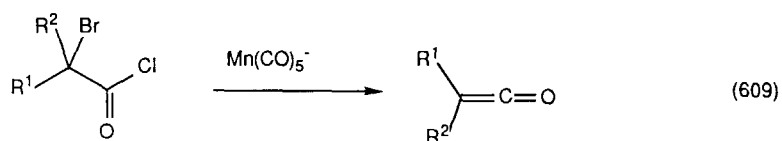

R = Ac, TMS

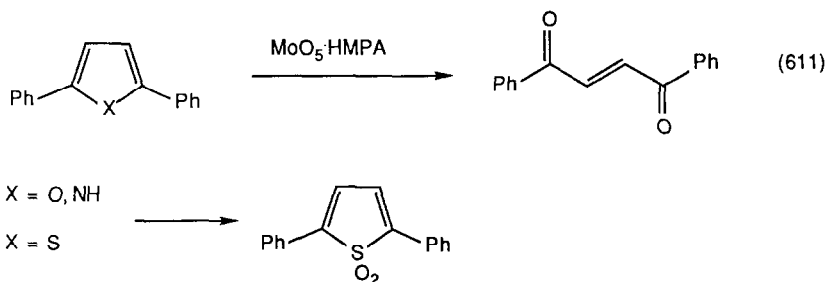

## H. Organosilanes

Asymmetric hydrosilylation and hydrocarbonylation has been reviewed [732]. Ruthenium carbonyls catalyzed the conversion of alkenes to vinyl silanes (equation 612) [733]. Chiral palladium(II) complexes catalyzed the asymmetric hydrosilylation of alkenes (equation 613) [734] and alkylation of vinyl bromides by trimethylsilyl alkyl Grignard reagents (equation 614). Alkynes were silylstannated (equation 615) [735] and hydrosilylated (equation 616) [736], (equation 617) [737] alkynes.

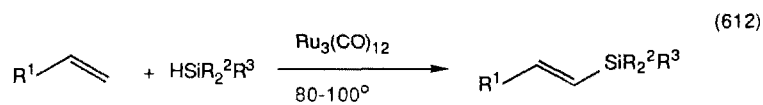

$R^1 = Ph, pMePh, pMeOPh, pClPh, 2-Napht, tBu, nBuO, Et_3Si, CO_3Et, H$

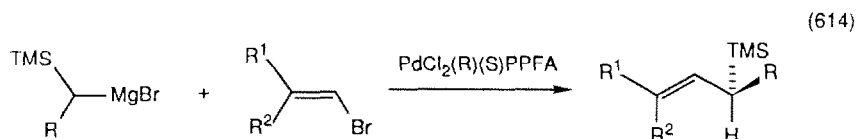
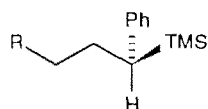
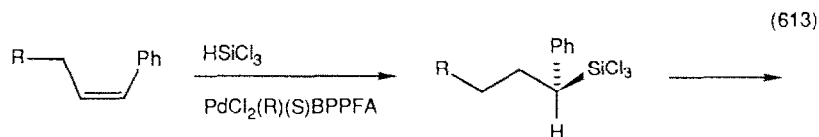

$R = Me, Ph$

60-80%  
60-95% ee

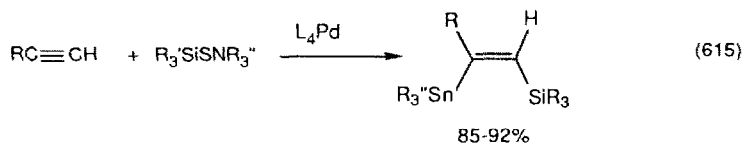

$R = Ph, nC_4, iPr, tBu, TMS, NC-CH_2-CH_2-CH_2-CH_2-CH_2-$

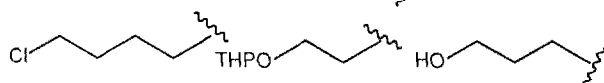

$R' = Me, Me_2Ph, BuMe_2; R'' = Bu, Me$



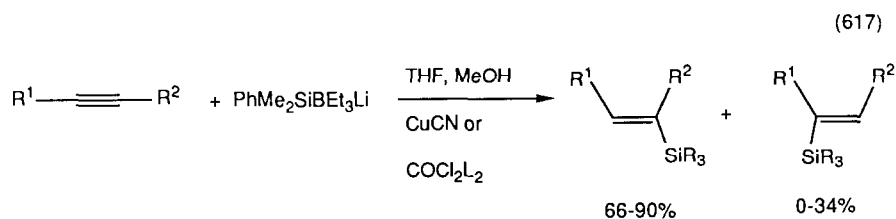
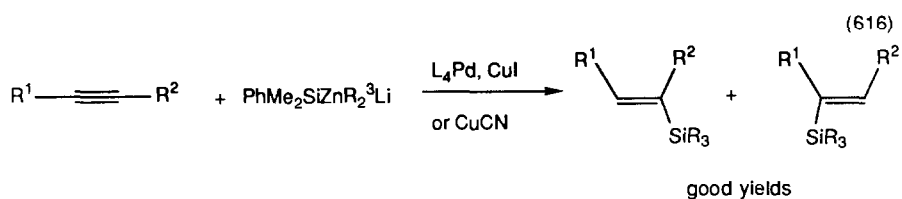

Vinyl halides, phosphates, sulfides and triflates were silylated by silylmanganese compounds (equation 618) [738]. Allenes were silylcuprated by disilylcopper compounds (equation 619) [739]. Chromium-complexed paracyclophanes were lithiated, then silylated by trimethylsilyl chloride (equation 620) [740]. Isocyanides were converted to silyl-stanyl imines using palladium(O) catalysts (equation 621) [741]. Cyclic disilyl compounds were made by the photocycloaddition shown in equation 622 [742].

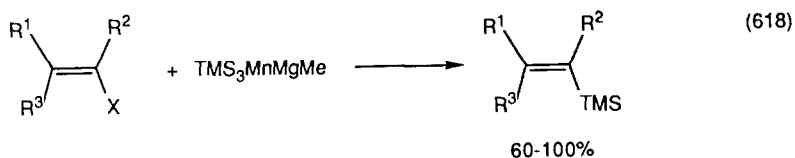

R<sup>1</sup> = Me, nC<sub>10</sub>, H, nC<sub>5</sub>, Ph  
(CH<sub>2</sub>)<sub>5</sub>, (CH<sub>2</sub>)<sub>6</sub>

R<sup>2</sup> = H, nC<sub>5</sub>, nC<sub>6</sub>, nBu, nC<sub>10</sub>

R<sup>3</sup> = H, Me, nC<sub>10</sub>, Ph

X = Br, I, SMe, OPO(OPh)<sub>2</sub>, OTf

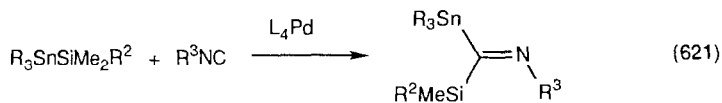
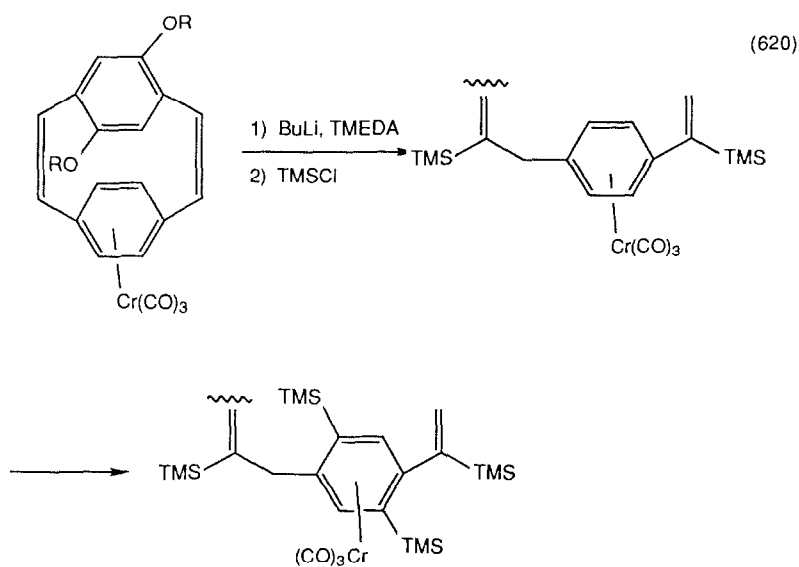
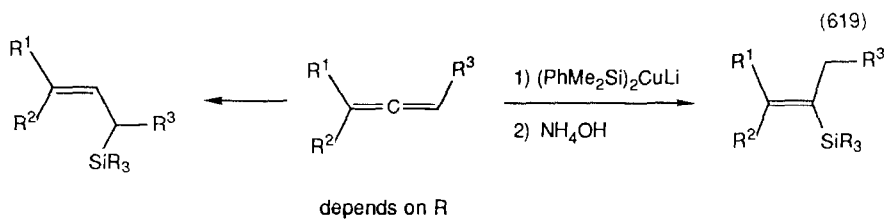

528-71

$R^1 = \text{Me, } n\text{C}_6, \text{otolyl, } n\text{Bu}$

$R^2 = \text{Me, tBu}$

$R^3 = \text{iPr, } n\text{C}_6, \text{otolyl,}$

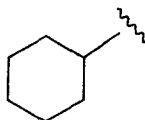

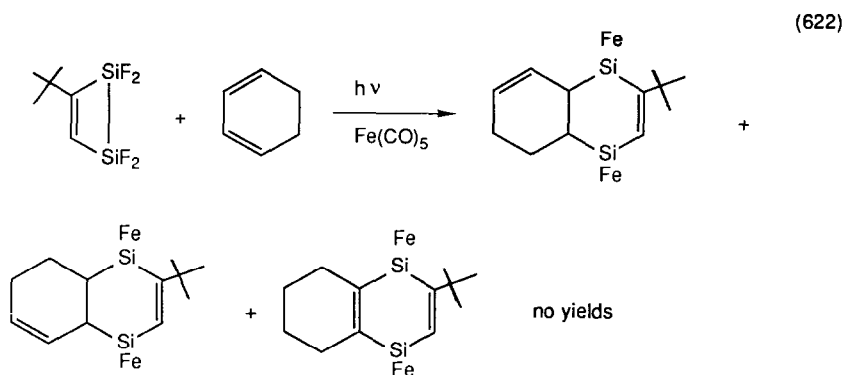

### I. Miscellaneous

Allyl acetates, carbonates and epoxides were converted to allyl thio ethers by palladium catalyzed reaction with RSTMS (equation 623) [743]. Aryl halides were converted to thiophenyl ethers by the palladium catalyzed reaction with trialkyl tin sulfides (equation 624) [744]. Chiral ruthenium(II) complexes catalyzed the addition of aryl sulfonyl chloride to olefins (equation 625) [745], while palladium(0) catalyzed diene addition and telomerization with phenylsulfonic and salts (equation 626) [746], and allyl nitro displacement (equation 627) [747]. Cobalt(II) chloride catalyzed the conversion of acid chlorides to thioesters (equation 628) [748]. Chiral titanium(IV) tartrates catalyzed the asymmetric oxidation of sulfides to chiral sulfoxides by *t*-butylhydroperoxides [749]. Nickel(II) salts catalyzed the conversion of vinyl halides to vinyl selenides or sulfides (equation 629) [750].

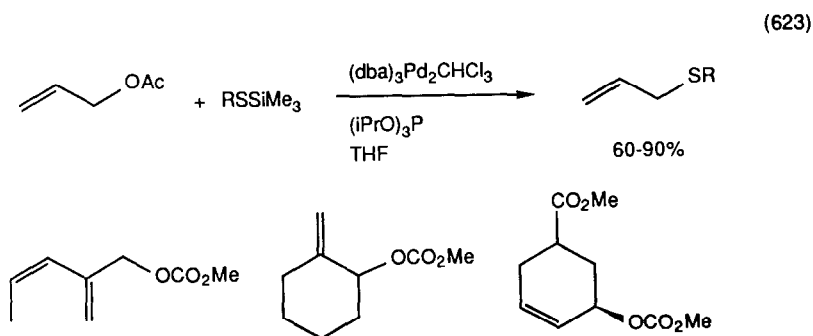

(equation 623 continued)

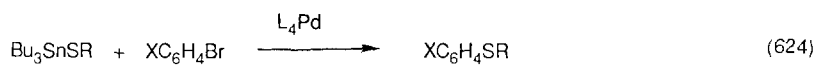
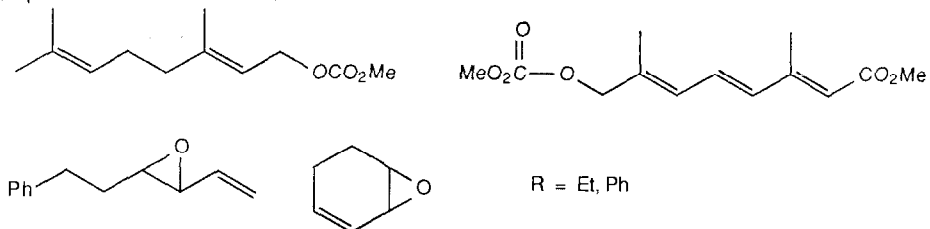

34-100%

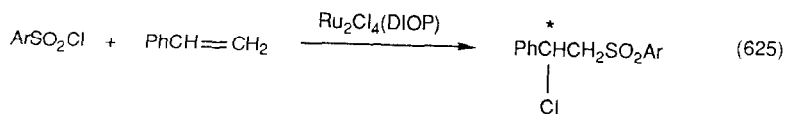
R = Ph; X = H, pMe, oMe, pMeO, oMeO, pCl, oCl, pMeCO, pCN, pNO<sub>2</sub>, 2,4,6-Me<sub>3</sub>

Ar = Ph, pMePh, pClPh, pMeOPh

22-45% ee

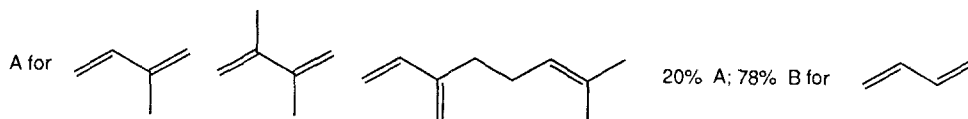
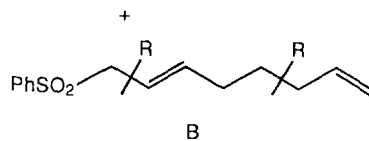
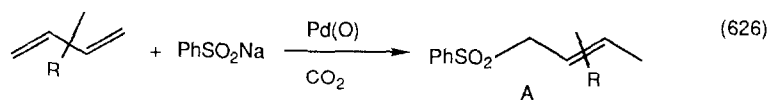

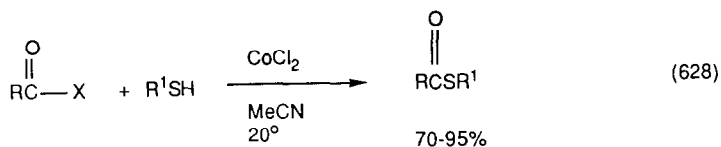
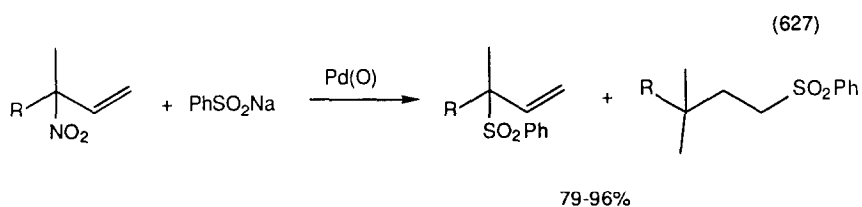

R = Me, Ph, Et, nPr

R<sup>1</sup> = Ph, pBrPh, Bz, pMePh, oNH<sub>2</sub>Ph

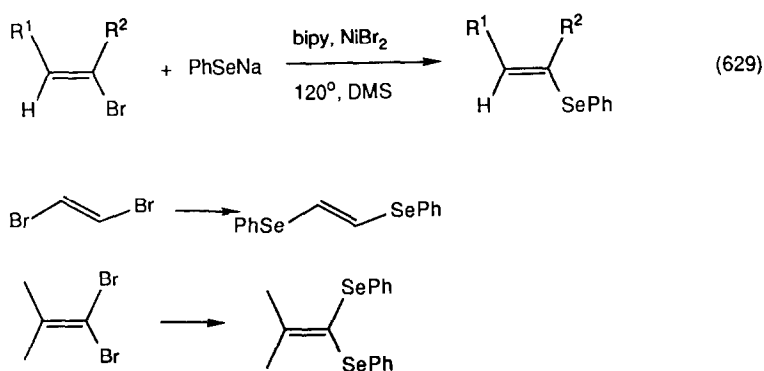
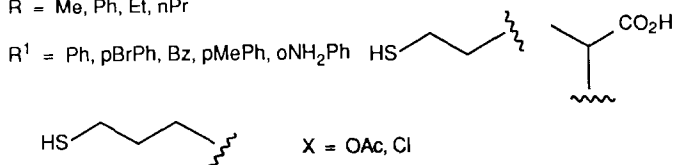

Vinyl halides (equation 630) [751], (equation 632) [752], vinyl halides (equation 633) [753] and allyl acetates and carbonates were converted to the corresponding oxophosphonous species using palladium or nickel catalysis. Nitroolefins were converted to oximes by palladium catalyzed reaction with sodium hypophosphite (equation 634) [755]. Nitrobenzene was carbonylated to phenylisocyanate over polymer supported anionic iron or osmium clusters [756].

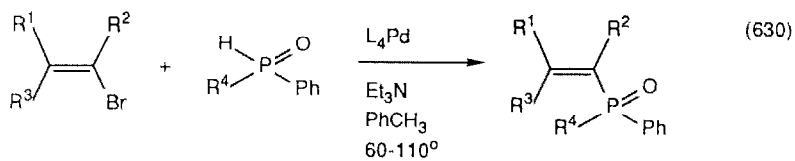

$\text{R}^1 = \text{H, Me, Ph, CO}_2\text{Me}$

$\text{R}^2 = \text{H, Me, Ph}$

$\text{R}^3 = \text{H}$

$\text{R}^4 = \text{Ph, Ph-CH}_2\text{-CH}_2\text{-CH}_2\text{-}$

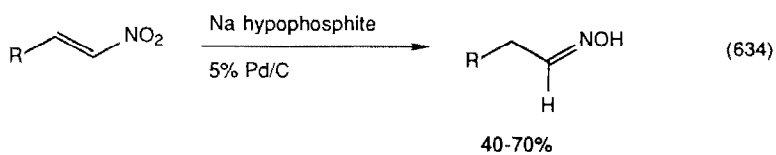
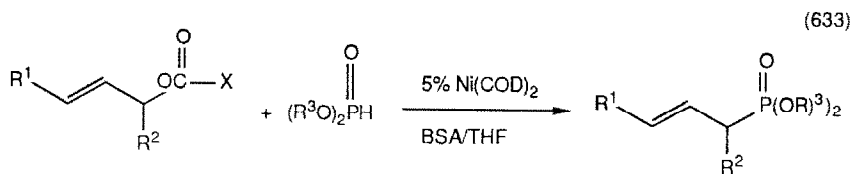
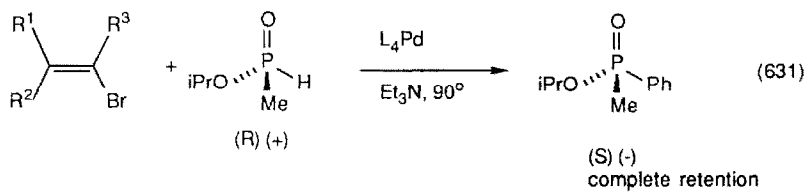

(equation 634 continued)

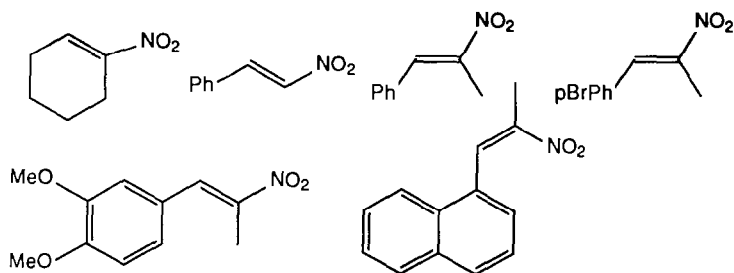

Two new ligands for catalysis have been developed (equation 635) [757], (equation 636) [757].

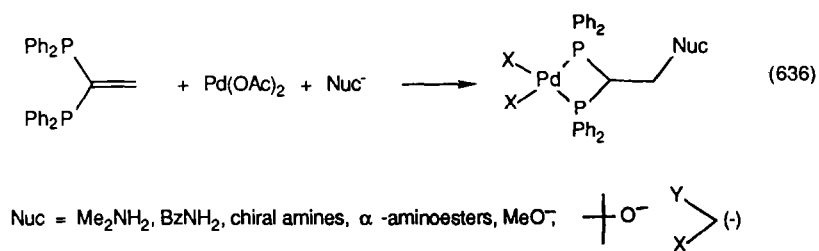
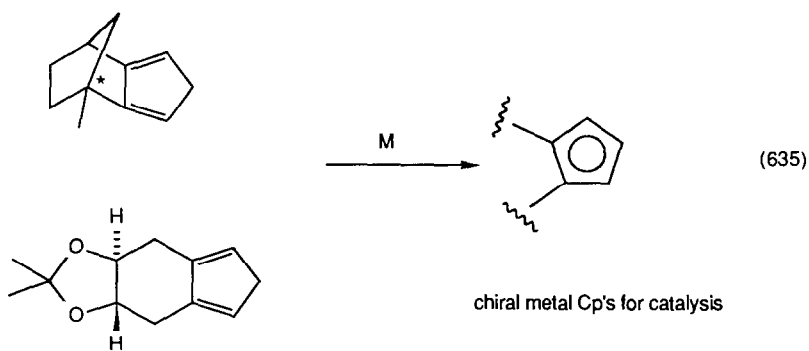

## IV. Reviews

The following review articles and dissertations have been published.

- Homogeneous catalysis by transition-metal complexes (330 references) [759].  
Transition metal alkyls, a personal perspective (108 references) [760].  
Photocatalytic reactions on metal-complex catalysts (72 references) [761].  
Triphase catalysis in organometallic anion chemistry [762].  
Binuclear metallocenes (122 references) [763].  
Rhodium and Iridium (286 references) [764].  
Rhenium - 1982 review (143 references) [765].  
Manganese - 1983 review (444 references) [766].  
Transition metal chemistry review, 1982, Part B [767].  
Incorporation of radiohalogens via versatile organometallic reactions: applications in radiopharmaceutical chemistry (19 references) [768].  
Twelfth International Conferences in Organometallic Chemistry [769].  
Catalytic oxidations in organic synthesis (63 references) [770].  
The organometallic chemistry of transition metal porphyrin complexes (54 references) [771].  
A new role for organometallic reactions in organic synthesis in industry (21 references) [772].  
Highly selective organometallic reagents (0 references) [773].  
Organometals as key compounds in novel organic syntheses. Their chemistry and application to chemical industry (31 references) [774].  
Synthetic processes in the organometallic chemistry of gold (11 references) [775].  
Transition metals in organic synthesis. Annual survey covering the year 1984 (890 references) [776].  
Multicomponent one-pot annulations forming three to six bonds (82 references) [777].  
The chemistry of metal-carbon bond, Vol. 2: the nature and cleavage of metal-carbon bonds [778].  
The chemistry of the metal-carbon bond, Vol. 3: carbon-carbon bond formation using organometallic compounds [779].  
Catalysis with coordination and organometallic compounds - application to organic synthesis (42 references) [780].  
Organometallics in synthesis (198 references) [781].  
Metal-catalyzed reactions of organic compounds (63 references) [782].  
Synthesis using transition metal complexes (3 references) [783].  
Synthesis and reactions of organotransition metal complexes [784].  
Transition metal complexes as catalysts in organic synthesis (45 references) [785].  
The role of metals in highly selective organic synthesis exploring new synthetic methodologies (52 references) [786].



- Group(VIII) metal-catalyzed carbon-carbon bond forming sequences (69 references) [787].
- Ring closing reactions of hydrocarbons on metal catalysts (420 references) [788].
- Selective carbon-hydrogen and carbon-carbon bond activation in alkanes by transition metal complexes [789].
- Activation of carbon-hydrogen bond of methane by organometallic complexes (14 references) [790].
- From silicon-hydrogen to carbon-hydrogen activation (57 references) [791].
- Activation of carbon-hydrogen bonds by metal complexes: mechanistic, kinetic and thermodynamic considerations [792].
- The activation of carbon-hydrogen bonds (33 references) [793].
- Zirconium complexes in synthesis and catalysis (147 references) [794].
- Niobium organometallic compounds: analysis and classification of crystallographic data (61 references) [795].
- Titanium - 1983 review (655 references) [796].
- Selective reactions of organotitanium reagents (36 references) [797].
- Homogeneous zirconium based catalysts in organic synthesis (76 references) [798].
- Applications of (propargylium)dicobalt hexacarbonyl complexes to organic syntheses [799].
- Organic chemistry of cyclic manganese carbonyl compounds (48 references) [800].
- Synthetically useful reactions with metal boride and aluminide catalysts (93 references) [801].
- Lewis acid promoted reactivity of transition metal complexes [802].
- New applications of organoboron complexes in organic synthesis (28 references) [803].
- Carbon-carbon bond formation using organometallic compounds of zinc, cadmium, and mercury (489 references) [804].
- Transition metal catalysis in organotin chemistry (68 references) [805].

## REFERENCES

1. J.A.Kozlowski; *Diss. Abstr. Int. B.*, **47**, 1051 (1986).
2. A.Alexakis, D.Jachiet, J.F.Normant, *Tetrahedron*, **42**, 5607 (1986).
3. J.K.Thottathil, J.L.Moniot, *Tetrahedron Lett.*, **27**, 151 (1986).
4. G.H.Posner, C.Switzer, *J. Am. Chem. Soc.*, **108**, 1239 (1986).
5. H.Malmberg, M.Nilsson, *Tetrahedron*, **42**, 3981 (1986).
6. P.W.J.Kens, P.Vermeer, *J. Organomet. Chem.*, **301**, 247 (1986).
7. B.H.Lipschutz, D.A.Parker, S.L.Nguyen, K.E.McCarthy, J.C.Barton, S.E.Whitney, H.Kotsuki, *Tetrahedron*, **42**, 2873 (1986).
8. H.Saimoto, T.Hiyama, *Tetrahedron Lett.*, **27**, 597 (1986).
9. D.J.Burton, S.W.Hansen, *J. Am. Chem. Soc.*, **108**, 4229 (1986).
10. D.M.Wiemers, D.J.Burton, *J. Am. Chem. Soc.*, **108**, 832 (1986).
11. P.L.Castle, D.A.Widdowson, *Tetrahedron Lett.*, **27**, 6013 (1986).
12. B.K.Vriesema, R.M.Kellogg, *Tetrahedron Lett.*, **27**, 2049 (1986).
13. B.K.Vriesema, M.Lemaive, J.Buter, R.M.Kellogg, *J. Org. Chem.*, **51**, 5169 (1986).
14. D.A.Widdowson, Y-Z.Zhang, *Tetrahedron*, **42**, 2111 (1986).
15. S.Araki, M.-Ohmura, Y.Butsugan, *Bull. Chem. Soc., Jpn.*, **59**, 2019 (1986).
16. R.Rossi, A.Carpita, *Tetrahedron Lett.*, **27**, 2529 (1986).
17. A.Carpita, R.Rossi, *Gazz. Chim. Ital.*, **115**, 575 (1985).
18. N.Jayasuriya, J.Kagan, *Heterocycles*, **24**, 2261 (1986).
19. C.V.Pham, H.B.Mark Jr., H.Zimmer, *Syn. Comm.*, **16**, 689 (1986).
20. J.L.Fabre, M.Julia, J.N.Verpeaux, *Bull. Soc. Chim., Fr.*, 762 (1985).
21. P.L.Buwalda, J.C.van de Grampel, *J. Chem. Soc., Chem. Commun.*, 1793 (1986).
22. J.K.Stille, *Angew. Chem. Int. Ed.*, **25**, 508 (1986).
23. J.K.Stille, *Pure Appl. Chem.*, **57**, 1771 (1985).
24. Y.Yamamoto, Y.Azuma, K.Mitoh, *Synthesis*, 564 (1986).
25. R.Sustmann, J.Law, M.Zipp, *Tetrahedron Lett.*, **27**, 5207 (1986).
26. M.Kosugi, T.Ishikawa, T.Nogami, T.Migita, *Nippon Kagaku Kaishi*, 502 (1985).
27. T.R.Bailey, *Tetrahedron Lett.*, **27**, 4407 (1986).
28. M.L.McLaughlin, J.A.McKinney, L.Paquette, *Tetrahedron Lett.*, **27**, 5595 (1986).
29. W.J.Scott, J.K.Stille, *J. Am. Chem. Soc.*, **108**, 3033 (1986).
30. L.Castedo, A.Mourino, L.A.Sarandeses, *Tetrahedron Lett.*, **27**, 1523 (1986).
31. T.H.Chan, K.Koumaglo, *Tetrahedron Lett.*, **27**, 883 (1986).
32. Y.Tamaru, H.Ochiai, T.Nakamura, Z.Yoshida, *Tetrahedron Lett.*, **27**, 955 (1986).
33. A.M.Caporusso, L.Larducci, F.De Settimo, *Tetrahedron Lett.*, **27**, 1067 (1986).
34. B.P.Andreini, A.Carpita, R.Rossi, *Tetrahedron Lett.*, **27**, 5533 (1986).
35. A.Carpita, R.Rossi, *Tetrahedron Lett.*, **27**, 4351 (1986).
36. P.L.Heinze, D.J.Burton, *J. Fluorine Chem.*, **31**, 115 (1986).
37. F.Tellier, R.Sauvetre, J.F.Normant, *J. Organomet. Chem.*, **303**, 309 (1986).
38. F.Tellier, R.Sauvetre, J.F.Normant, *Tetrahedron Lett.*, **27**, 3147 (1986).

39. E.Nakamura, I.Kuwajima, *Tetrahedron Lett.*, **27**, 83 (1986).
40. P.Knockel, J.F.Normant, *Tetrahedron Lett.*, **27**, 4431 (1986).
41. N.Miyaura, M.Satoh, A.Suzuki, *Tetrahedron Lett.*, **27**, 3745 (1986).
42. M.Satoh, N.Miyaura, A.Suzuki, *Chem. Lett.*, 1329 (1986).
43. N.Miyaura, T.Ishiyama, M.Ishikawa, A.Suzuki, *Tetrahedron Lett.*, **52**, 6369 (1986).
44. N.Miyaura, Y.Satoh, S.Hara, A.Suzuki, *Bull. Chem. Soc., Jpn.*, **59**, 2029 (1986).
45. M.Somei, H.Amari, Y.Makita, *Chem. Pharm. Bull.*, **34**, 3971 (1986).
46. T.Sakamoto, Y.Kondo, H.Yamanaka, *Heterocycles*, **24**, 31 (1986).
47. A.Tischler, T.J.Lanza, *Tetrahedron Lett.*, **27**, 1653 (1986).
48. R.Diercks, K.P.C.Vollhardt, *Angew. Chem. Int. Ed.*, **25**, 266 (1986).
49. R.J.Blade, J.E.Robinson, *Tetrahedron Lett.*, **27**, 3209 (1986).
50. Y.Akita, A.Inoue, A.Ohta, *Chem. Pharm. Bull.*, **34**, 1447 (1986).
51. D.Guillerm, G.Linstrumelle, *Tetrahedron Lett.*, **27**, 5857 (1986).
52. S.Cacchi, E.Morera, G.Ontar, *Synthesis*, 320 (1986).
53. Q-y.Chen, Z.Y.Yang, *Tetrahedron Lett.*, **27**, 1171 (1986).
54. B.Hipler, E.Uhlig, *Proc. Conf. Coord. Chem.*, 153 (1985).
55. F.T.Luo, *Diss. Abstr. Int. B.*, **46**, 525 (1985).
56. G.P.Chiusoli, *J. Organomet. Chem.*, **300**, 57 (1986).
57. Y.Z.Huang, Q.Zhou, *Tetrahedron Lett.*, **27**, 2397 (1986).
58. J-i.Setsune, T.Ueda, K.Shikata, K.Matsukawa, T.Iida, T.Kitao, *Tetrahedron*, **42**, 2647 (1986).
59. M.Kosugi, M.Koshika, A.Atoh, H.Sano, T.Migita, *Bull. Chem. Soc., Jpn.*, **59**, 677 (1986).
60. M. Kadokura, T-a. Mitsudo, Y. Watanabe, *J. C. S. Chem. Comm.*, 252 (1986).
61. P. Knochel, J. F. Normant, *Tetrahedron Lett.*, **27**, 4427 (1986).
62. N. Jabri, A. Alexakis, J. F. Normant, *Tetrahedron*, **42**, 1369 (1986).
63. J. Arukwe, K. Undheim, *Acta Chem. Scand.*, **B40**, 764 (1986).
64. G. Cahiez, J. Rivas-Enterrios, H. Granger-Veyron, *Tetrahedron Lett.*, **27**, 4441 (1986).
65. T. Hirao, D. Misu, K. Yao, T. Agawa, *Tetrahedron Lett.*, **27**, 929 (1986).
66. P. Ciattini, G. Ortar, *Synthesis*, 70 (1986).
67. N. Barr, J. P. Bartley, P. W. Clark, P. Dunstan, S. F. Dyke, *J. Organomet. Chem.*, **302**, 117 (1986).
68. Y. Akita, T. Noguchi, M. Sugimoto, A. Ohta, *J. Het. Chem.*, **23**, 1481 (1986).
69. Y. Akita, A. Inoue, K. Yamamoto, A. Ohta, T. Kurihara, M. Shimizu, *Heterocycles*, **23**, 2327 (1985).
70. K. Karabelas, A. Hallberg, *J. Org. Chem.*, **51**, 5286 (1986).
71. A. Arcadi, F. Mrinelli, S. Cacchi, *J. Organomet. Chem.*, **312**, C27 (1986).
72. G. Meyer, Y. Rollin, *C. R. Acad. Sci., Ser. 2*, **302**, 303 (1986).

73. G. Boldrini, D. Savoia, E. Tagliavini, C. Trombini, A. Umami Ronchi, *J. Organomet. Chem.*, **301**, C62 (1986).
74. K. Sugioka, M. Uchiyama, T. Suzuki, Y. Yamazaki, *Nippon Kagaku Kaishi*, 527 (1985).
75. Y. Xu, Z. Li, *Tetrahedron Lett.*, **27**, 3017 (1986).
76. J. C-Y. Cheng, G. Doyle Daves Jr., *Organomet.*, **5**, 1753 (1986).
77. J. C-Y. Cheng, U. Hacksell, G. Doyles Daves Jr., *J. Org. Chem.*, **51**, 3093 (1986).
78. R. C. Larock, S. S. Hershberger, K. Takagi, M. A. Mitchell, *J. Org. Chem.*, **51**, 2450 (1986).
79. R. C. Larock, D. R. Leach, S. M. Bjorge, *J. Org. Chem.*, **51**, 5221 (1986).
80. M. Somei, Y. Saida, N. Komura, *Chem. Pharm. Bull.*, **34**, 4116 (1986).
81. M. Somei, Y. Saida, *Heterocycles*, **23**, 3113 (1985).
82. R. A. Kjonaas, *J. Org. Chem.*, **51**, 3708 (1986).
83. T. Itahara, *Chem. Lett.*, 239 (1986).
84. A. D. Ryabov, I. K. Sakodinskaya, S. N. Dvoryantsev, A. V. Eliseev, A. K. Yatsimirshi, L. G. Kuzmina, Yu. T. Struchov, *Tetrahedron Lett.*, **27**, 2169 (1986).
85. L. N. Lewis, J. F. Srnith, *J. Am. Chem. Soc.*, **108**, 2728 (1986).
86. U. M. Dzhemilev, O. S. Vostrikova, R. M. Sultanov, *Izv. Akad. Nauk SSSR, Ser. Khim.*, 1430 (1985).
87. Q. Y. Chen, Z. Y. Yang, *J. C. S. Chem. Comm*, 498 (1986).
88. Q. Chen, Z. Yang, *Huaxue Xuebao*, **43**, 1118 (1985).
89. T. Ishihara, M. Kuroboshi, Y. Okada, *Chem. Lett.*, 1895 (1986).
90. Q. Chen, Z. Yang, *Youji Huaxue*, 41 (1986).
91. D. Bellus, *Pure Appl. Chem.*, **57**, 1827 (1985).
92. V. V. Startsev, L. M. Zubritskii, A. A. Petrov, *Zh. Org. Khim.*, **21**, 1128 (1985).
93. L. E. Torres, G. L. Larson, *Tetrahedron Lett.*, **27**, 2223 (1986).
94. Y. Tamaru, M. Hojo, H. Higashimura, Z. Yoshida, *Angew. Chem.*, **98**, 740 (1986).
95. T. K. Hayes, A. J. Freyer, M. Parvez, S. M. Weinreb, *J. Org. Chem.*, **51**, 5501 (1986).
96. G. P. Chiusoli, M. Costa, P. Schianchi, G. Salerno, *J. Organomet. Chem.*, **315**, C45 (1986).
97. J. M. Takacs, L. G. Anderson, G. V. Bundu, Madhaven, M. W. Creswell, F. L. Seely, W. P. Devroy, *Organomet.*, **5**, 2395 (1986).
98. J. C. Heslin, C. J. Moody, A. M. Z. Slawin, D. J. Williams, *Tetrahedron Lett.*, **27**, 1403 (1986).
99. K. N. Mehrotra, G. S. Singh, *Indian J. Chem., Sect. B*, **24B**, 773 (1985).
100. C. W. Jefford, T. Kubota, A. Zaslona, *Helv. Chim. Acta*, **69**, 2048 (1986).
101. M. Heytsak, N. Etkin, T. Durst, *Tetrahedron Lett.*, **27**, 5679 (1986).
102. D. F. Taber, R. E. Ruckle, Jr., *J. Am. Chem. Soc.*, **108**, 7686 (1986).
103. A. Padwa, S. P. Carter, H. Nimmegern, *J. Org. Chem.*, **51**, 1157 (1986).

104. D. F. Taber, J. C. Armedio, Jr., R. G. Sherrill, *J. Org. Chem.*, **51**, 3382 (1986).
105. T. Aratani, *Pure Appl. Chem.*, **57**, 1839 (1985).
106. T. Aratani, *Yuki Gosei Kagaku Kyokaishi*, **43**, 1134 (1985).
107. H. Fritschi, U. Leutenegger, A. P. Faltz, *Angew Chem. Int. Ed.*, **25**, 1005 (1986).
108. J. C. Oudenjans, J. Kaminska, A. C. Koch-van Dalen, H-van Bekkum, *Rec. Trav. Chim.*, **105**, 421 (1986).
109. Yu-V. Tomilov, T. L. Mitenina, A. I. Lutsenko, I. E. Dolgii, S. P. Kolesnikov, O. M. Nefedov, *Izv. Akad. Nauk SSSR, Ser. Khim.*, 77 (1986).
110. A. Jeganathan, S. K. Richardson, R. Mani, B. E. Haley, D. S. Watt, *J. Org. Chem.*, **51**, 5362 (1986).
111. P. deMarch, M. Moreno-Manas, I. R. Poll, F. Florencso, S. Garcia-Blanco, S. Martinez-Carrera, *Tetrahedron Lett.*, **27**, 3673 (1986).
112. A. Padwa, T. J. Wisnieff, E. J. Walsh, *J. Org. Chem.*, **51**, 5036 (1986).
113. J. Adams, M. Belley, *Tetrahedron Lett.*, **27**, 2075 (1986).
114. K. Kikukawa, H. Umekawa, T. Matsuda, *J. Organomet. Chem.*, **311**, C44 (1986).
115. K. Ikenaga, K. Kikukawa, T. Matsuda, *J. C. S. Perkin I*, 1959 (1986).
116. A. Atterio, D. Cominelli, F. Bonavoglia, *Synthesis*, 308 (1986).
117. J. A. Smegal, I. K. Meier, J. Schwartz, *J. Am. Chem. Soc.*, **108**, 1322 (1986).
118. B. M. Trost, *Angew Chem. Int. Ed.*, **25**, 1 (1986).
119. B. M. Trost, S. Mignani, *J. Org. Chem.*, **51**, 3435 (1986).
120. B. M. Trost, S. M. Mignani, T. N. Nanniga, *J. Am. Chem. Soc.*, **108**, 6051 (1986).
121. B. M. Trost, J. Lynch, P. Renaut, D. S. Steinman, *J. Am. Chem. Soc.*, **108**, 284 (1986).
122. B. M. Trost, S. M. Mignani, *Tetrahedron Lett.*, **27**, 4137 (1986).
123. B. M. Trost, J. M. Balkover, S. R. Angle, *Tetrahedron Lett.*, **27**, 1445 (1986).
124. M. D. Jones, R. D. W. Kammatt, *J. C. S. Chem. Comm.*, 1201 (1986).
125. B. M. Trost, S. A. King, *Tetrahedron Lett.*, **27**, 5971 (1986).
126. R. S. Glass, W. W. McConnell, S. W. Andruski, *J. Org. Chem.*, **51**, 5123 (1986).
127. C. S. Liu, C. H. Lin, C. Y. Lee, *Organosilicon Bioorganosilicon Chem.*, 167 (1985).
128. R. Grigg, J. Devlin, *J. Chem. Soc., Chem. Commun.*, 631 (1986).
129. J. P. Foulon, M. Bourgain-Commercon, J. F. Normant, *Tetrahedron*, **42**, 1389 (1986).
130. N. Chatani, T. Takeyasu, T. Hanafusa, *Tetrahedron Lett.*, **27**, 1841 (1986).
131. T. N. Mitchell, A. Amamria, H. Killing, D. Rutschow, *J. Organomet. Chem.*, **304**, 256 (1986).
132. A. Arcadi, S. Cacchi, F. Marinelli, *Tetrahedron Lett.*, **52**, 6397 (1986).
133. V. Rautenstrauch, *Chimica*, **39**, 227 (1985).
134. D. L. Reger, S. A. Klaeren, L. Lebioda, *Organomet.*, **5**, 1072 (1986).
135. D. L. Reger, E. Mintz, L. Lebioda, *J. Am. Chem. Soc.*, **108**, 1940 (1986).

136. W. A. Smit, A. S. Gybin, A. S. Shashkov, Y. T. Strychov, L. G. Kyz'mina, G. S. Mikaelian, R. Caple, E. D. Swanson, *Tetrahedron Lett.*, **27**, 1241 (1986).
137. W. A. Smit, A. S. Gybin, A. S. Shashkov, Y. T. Strychov, L. G. Kyz'mina, G. S. Mikaelian, R. Caple, E. D. Swanson, *Tetrahedron Lett.*, **27**, 1245 (1986).
138. M. Saha, B. Bagby, K. M. Nicholas, *Tetrahedron Lett.*, **27**, 915 (1986).
139. M. Saha, S. Muchmore, D. van der Helm, K. M. Nicholas, *J. Org. Chem.*, **51**, 1960 (1986).
140. S. L. Schreiber, T. Sammakia, W. A. Crowe, *J. Am. Chem. Soc.*, **108**, 3128 (1986).
141. L. S. Liebeskind, S. L. Maydson, V. Goedkin, R. Chidambaram, *Organomet.*, **5**, 1086 (1986).
142. C. C. Tseng, S. D. Paisley, H. L. Goering, *J. Org. Chem.*, **51**, 2884 (1986).
143. C. C. Tseng, S.-J. Yen, H. L. Goering, *J. Org. Chem.*, **51**, 2892 (1986).
144. I. Fleming, A. P. Thomas, *J. C. S. Chem. Comm.*, 1456 (1986).
145. G. Consiglio, O. Piccolo, L. Roncetti, F. Morandini, *Tetrahedron*, **42**, 2043 (1986).
146. T. Cuvignz, M. Julia, *J. Organomet. Chem.*, **317**, 383 (1986).
147. U. M. Dzhemilev, A. G. Ibragimov, E. V. Gribanova, L. M. Khalilov, *Izv. Akad. Nauk SSSR, Ser. Khim.*, 2562 (1985).
148. J.-C. Fiand, L. Aribi-Zouioueche, *J. C. S. Chem. Comm.*, 390 (1986).
149. E.-i. Negishi, Y. Zhang, F. E. Cederbaum, M. B. Webb, *J. Org. Chem.*, **51**, 4080 (1986).
150. I. Marek, P. Mangeney, A. Alexakis, J. F. Normant, *Tetrahedron Lett.*, **27**, 5499 (1986).
151. M. Lautens, *Diss. Abstr. Int. B.*, **46**, 3055 (1986).
152. M. Capobianco, E. Mezzina, D. Savoia, E. Tagliavini, C. Trombini, A. Umani-Ronchi, *Tetrahedron Lett.*, **27**, 1387 (1986).
153. J. P. Genet, S. Grisoni, *Tetrahedron Lett.*, **27**, 4165 (1986).
154. S. A. Godleski, E. B. Villhauer, *J. Org. Chem.*, **51**, 486 (1986).
155. D. Ferrond, J. P. Genet, R. Kiolle, *Tetrahedron Lett.*, **27**, 23 (1986).
156. J. P. Genet, D. Ferroud, S. Juge, J. R. Montes, *Tetrahedron Lett.*, **27**, 4573 (1986).
157. G. P. Boldrini, M. Mengoli, E. Taghavini, C. Trombini, A. Umani-Ronchi, *Tetrahedron Lett.*, **27**, 4223 (1986).
158. M. Minato, T. Nonaka, T. Fuchigami, *Chem. Lett.*, 1071 (1986).
159. D. Ferroud, J. M. Gaudin, J. P. Genet, *Tetrahedron Lett.*, **27**, 845 (1986).
160. Y. Hori, T.-a Mitsudo, Y. Watanabe, *Tetrahedron Lett.*, **27**, 5389 (1986).
161. T. Tsuda, M. Okada, S.-i. Nishi, T. Saegusa, *J. Org. Chem.*, **51**, 421 (1986).
162. T. Hayashi, A. Yamamoto, Y. Ito, *J. C. S. Chem. Comm.*, 1090 (1986).
163. T. Hayashi, A. Yamamoto, T. Hagihara, *J. Org. Chem.*, **51**, 723 (1986).
164. T. Hayashi, A. Yamamoto, T. Hagihara, Y. Ito, *Tetrahedron Lett.*, **27**, 191 (1986).
165. F. E. Ziegler, A. Kneisley, R. T. Wester, *Tetrahedron Lett.*, **27**, 1221 (1986).

166. K. Hiroi, K. Suya, S. Sato, *J. Chem. Soc., Chem. Commun.*, 469 (1986).
167. X. Lu, Y. Huang, *Tetrahedron Lett.*, **27**, 1615 (1986).
168. R. Tamura, Y. Kai, M. Kakihana, K. Hayashi, M. Tsuji, T. Nakamura, D. Oda, *J. Org. Chem.*, **51**, 4375 (1986).
169. N. Ono, I. Hashimoto, A. Kaji, *J. C. S. Perkin I*, 1439 (1986).
170. N. Ono, I. Hashimoto, A. Kaji, *J. Org. Chem.*, **51**, 2832 (1986).
171. Y. Inoue, M. Toyofuku, M. Taguchi, S-i. Okada, H. Hashimoto, *Bull. Chem. Soc., Jpn.*, **59**, 885 (1986).
172. P. Auviay, P. Knochel, J. F. Normant, *Tetrahedron Lett.*, **27**, 5095 (1986).
173. J. C. Flaud, B. Denner, J. L. Malleron, *J. Organomet. Chem.*, **291**, 393 (1985).
174. X. Lu, L. Lu, *J. Organomet. Chem.*, **307**, 285 (1986).
175. Y. Yokoyama, S. Ito, Y. Takahashi, Y. Murakami, *Tetrahedron Lett.*, **26**, 6457 (1985).
176. B. M. Trost, C. J. Urch, M-H. Hung, *Tetrahedron Lett.*, **27**, 4949 (1986).
177. R. C. Larock, S. J. Iekka, *Tetrahedron Lett.*, **27**, 2211 (1986).
178. T. Tsuda, M. Tokai, I. Ishida, T. Saegusa, *J. Org. Chem.*, **51**, 5216 (1986).
179. B. M. Trost, J. T. Hane, P. Metz, *Tetrahedron Lett.*, **27**, 5695 (1986).
180. T. Takahashi, M. Miyazawa, H. Ueno, J. Tsuji, *Tetrahedron Lett.*, **27**, 3881 (1986).
181. T-a. Mitsudo, M. Kadokura, Y. Watanabe, *J. C. S. Chem. Comm.*, 1539 (1986).
182. G. Balme, G. Fournet, J. Goro, *Tetrahedron Lett.*, **27**, 3855 (1986).
183. W. Smadja, S. Czernecki, G. Ville, C. Georgoulis, *Organometallics*, **6**, 166 (1987).
184. T. Tabuchi, J. Iananaga, M Yamaguchi, *Tetrahedron Lett.*, **27**, 5237 (1986).
185. E. Keinan, E. Bosch, *J. Org. Chem.*, **51**, 4006 (1986).
186. G. Bontempelli, M. Fiorani, *Ann. Chim. (Rome)*, **75**, 303 (1985).
187. Y. Rollin, M. Troupel, D. G. Tuck, J. Perichon, *J. Organomet. Chem.*, **303**, 131 (1986).
188. R. Vanderesse, M. Lourak, Y. Font, P. Caubere, *Tetrahedron Lett.*, **27**, 5483 (1986).
189. J. Yamashita, Y. Inoue, T. Kondo, H. Hashimoto, *Chem. Lett.*, 407 (1986).
190. I. Colon, D. R. Kelsey, *J. Org. Chem.*, **51**, 2627 (1986).
191. R. Vanderese, Y. Fort, S. Becker, P. Caubere, *Tetrahedron Lett.*, **27**, 3517 (1986).
192. J-i. Yoshida, H. Funahashi, H. Iwasahi, N. Kawabata, *Tetrahedron Lett.*, **27**, 4467 (1986).
193. P. Li, H. Alper, *J. Org. Chem.*, **51**, 4354 (1986).
194. R. Jaouhari, P. Geunot, P. H. Dixneuf, *J. C. S. Chem. Comm.*, 1255 (1986).
195. Y. Landais, J-P. Robin, *Tetraedron Lett.*, **27**, 1785 (1986).
196. Y. Landais, A. Lebrun, J. P. Robin, *Tetrahedron Lett.*, **27**, 5377 (1986).
197. J. Nishimura, N. Yamada, Y. Horiuchi, E. Ueda, A. Ohbayashi, A. Oku, *Bull. Chem. Soc., Jpn.*, **59**, 2035 (1986).

198. J. P. Foulon, M. Bourgain-Commercon, J. F. Normant, *Tetrahedron*, **42**, 1399 (1986).
199. A. Hosomi, K. Otaka, H. Sakurai, *Tetrahedron Lett.*, **27**, 2881 (1986).
200. R. J. McKinney, M. C. Colton, *Organometallics*, **5**, 1080 (1986).
201. M. Ito, Y. Ishii, S. Hamanaka, M. Ogawa, *Sekiyu Gakkaishi*, **29**, 246 (1986).
202. C. Bleasdale, D. W. Jones, *J. C. S., Perkin I*, 157 (1986).
203. G. Suess-Fink, G. Herrmann, *Angew. Chem.*, **98**, 568 (1986).
204. K. Avasthi, R. G. Salomon, *J. Org. Chem.*, **51**, 2556 (1986).
205. P. A. Wiender, N. C. Ihle, *J. Am. Chem. Soc.*, **108**, 4678 (1986).
206. E-i. Negishi, F. E. Cederbaum, T. Takahashi, *Tetrahedron Lett.*, **27**, 2829 (1986).
207. J-M. Pons, M. Santelli, *Tetrahedron Lett.*, **27**, 4153 (1986).
208. E. Vogel, M. Kocher, H. Schmickler, J. Lex, *Angew. Chem. Int. Ed.*, **25**, 257 (1986).
209. R. H. Mitchell, S. Ananda Weerawarna, *Tetrahedron Lett.*, **27**, 453 (1986).
210. C. S. Wong, W. S. Leung, L. L. Yeung, T-Y. Luh, *J. Organomet. Chem.*, **307**, C49 (1986).
211. A. Clerici, O. Porta, P. Zago, *Tetrahedron*, **42**, 561 (1986).
212. J. Tsuji, *Tetrahedron*, **42**, 4361 (1986).
213. F. Sato, *Chem. Met.-Carbon Bond*, **3**, 201 (1985).
214. T. Hayashi, M. Kumada, *Asymmetric Synth.*, **5**, 147 (1985).
215. A. E. Goliaszewski, *Diss. Abstr. Int. B.*, **46**, 3845 (1986).
216. Y. R. Hu, *Diss. Abstr. Int. B.*, **46**, 3847 (1986).
217. T. Yamamoto, M. Akimoto, O. Saito, A. Yamamoto, *Organomet.*, **5**, 1559 (1986).
218. D. R. Chrisope, P. Beak, *J. Am. Chem. Soc.*, **108**, 334 (1986).
219. S. Imaizumi, T. Matsuhisa, Y. Senda, *Nippon Kagaku Kaishi*, 288 (1985).
220. W. A. Donaldson, V. J. Grief, *Tetrahedron Lett.*, **27**, 2345 (1986).
221. R. C. Larock, K. Takagi, J. P. Burkhart, S. A. Hershberger, *Tetrahedron*, **42**, 3759 (1986).
222. H. Kurosawa, A. Urabe, *Chem. Lett.*, 1839 (1985).
223. H. Kurosawa, A. Urabe, K. Miki, N. Kasai, *Organomet.*, **5**, 2003 (1986).
224. L. S. Barinelli, K. Tao, K. M. Nicholas, *Organomet.*, **5**, 588 (1986).
225. G. S. Silverman, S. Strickland, K. M. Nicholas, *Organometallics*, **5**, 2117 (1986).
226. G. A. Molander, D. C. Shubert, *Tetrahedron Lett.*, **27**, 787 (1986).
227. Y. Yamamoto, S. Nishii, K. Maruyama, *J. C. S. Chem. Comm.*, 102 (1986).
228. E. Nakamura, H. Oshino, I. Kuwajima, *J. Am. Chem. Soc.*, **108**, 3745 (1986).
229. H. Hagihara, K. Kimura, H. Uda, *J. C. S. Chem. Comm.*, 860 (1986).
230. C. Palazzi, L. Colombo, C. Gennari, *Tetrahedron Lett.*, **27**, 1735 (1986).
231. D. Seebach, R. Imwinkelried, G. Stucky, *Angew. Chem. Int. Ed.*, **25**, 178 (1986).
232. C. Siegel, E. R. Thorton, *Tetrahedron Lett.*, **27**, 457 (1986).
233. S. Sato, I. Matsuda, Y. Izumi, *Chem. Lett.*, 1875 (1985).



234. S. Sato, I. Matsuda, Y. Izumi, *Tetrahedron Lett.*, **27**, 5517 (1986).
235. M. T. Reetz, S. H. Kyung, C. M. Hüllmann, *Tetrahedron Lett.*, **42**, 2931 (1986).
236. M. T. Reetz, T. Kükenhöhnner, P. Weinig, *Tetrahedron Lett.*, **27**, 5711 (1986).
237. P. L. Coe, C. E. Scriven, *J. C. S., Perkin I*, 475 (1986).
238. S. Madhava Reddy, M. Duraisamy, H. M. Walborsky, *J. Org. Chem.*, **51**, 2361 (1986).
239. T. Hirao, D. Misa, T. Agawa, *Tetrahedron Lett.*, **27**, 933 (1986).
240. G. Cahiez, B. Figadere, *Tetrahedron Lett.*, **26**, 4445 (1986).
241. T. Kauffmann, K. Abel, W. Bonrath, M. Kolb, T. Möller, C. Pahde, S. Raldecher, M. Robert, M. Wensing, B. Wichmann, *Tetrahedron Lett.*, **27**, 5351 (1986).
242. M. Kusakake, F. Sato, *J. C. S. Chem. Comm.*, 989 (1986).
243. S. Okamoto, T. Shimazaki, Y. Kitano, Y. Kobayashi, F. Sato, *J. C. S. Chem. Soc. Comm.*, 1352 (1986).
244. M. Kusakake, F. Sato, *Chem. Lett.*, 1473 (1986).
245. C. Jenny, P. Wipf, H. Heimgartner, *Helv. Chim. Acta*, **69**, 1837 (1986).
246. N. A. Shams, *J. Prakt. Chem.*, **327**, 536 (1985).
247. H. Shibuya, K. Okashi, K. Kawashima, K. Hori, N. Murakami, I. Kitigawa, *Chem. Lett.*, 85 (1986).
248. H. Jin, J.-i. Uenishi, W. J. Christ, Y. Kishi, *J. Am. Chem. Soc.*, **108**, 5644 (1986).
249. K. Takai, M. Tagashira, T. Kuroda, K. Oshima, K. Utimoto, H. Nozaki, *J. Am. Chem. Soc.*, **108**, 6048 (1986).
250. K. Takai, K. Nitta, K. Utimoto, *J. Am. Chem. Soc.*, **108**, 7408 (1986).
251. T. Tabuchi, J. Inanaga, M. Yamaguchi, *Tetrahedron Lett.*, **27**, 1195 (1986).
252. Y. Inoue, M. Toyofuku, H. Hashimoto, *Bull. Chem. Soc., Jpn.*, **59**, 1279 (1986).
253. M. Moreno-Mañas, R. M. Ortuño, M. Prat, M. A. Galan, *Synth. Comm.*, **16**, 1003 (1986).
254. M. Uemura, T. Minami, K. Isobe, T. Kobuyashi, Y. Hayashi, *Tetrahedron Lett.*, **27**, 967 (1986).
255. E. P. Kundig, *Pure Appl. Chem.*, **57**, 1855 (1985).
256. J. L. Blagg, S. G. Davies, *J. C. S. Chem. Comm.*, 492 (1986).
257. J. P. Gilday, D. A. Widdowson, *J. C. S. Chem. Comm.*, 1235 (1986).
258. J. P. Gilday, D. A. Widdowson, *Tetraedron Lett.*, **27**, 5525 (1986).
259. J. Hamilton, C. A. L. Mahaffy, *Synth. React. Inorg. Met.-Org. Chem.*, **16**, 61 (1986).
260. W. R. Jackson, I. D. Rae, M. G. Wong, *Aust. J. Chem.*, **39**, 303 (1986).
261. A. Alemagna, C. Baldoli, P. Del Buttero, E. Licandro, S. Maiorana, *Gazz. Chim. Ital.*, **115**, 555 (1985).
262. F. Rose-Munch, E. Rose, A. Semra, *J. C. S. Chem. Comm.*, 1108 (1986).
263. F. Rose-Munch, E. Rose, A. Semra, *J. C. S. Chem. Comm.*, 1551 (1986).
264. M. Uemura, T. Minami, Y. Hayashi, *J. Organomet. Chem.*, **299**, 119 (1986).
265. M. Uemura, T. Kobayashi, Y. Hayashi, *Synthesis*, 386 (1986).

266. M. Uemura, T. Kobayashi, K. Isobe, T. Minami, Y. Hayashi, *J. Org. Chem.*, **51**, 2859 (1986).
267. M. Uemura, T. Kobayashi, T. Minami, Y. Hayashi, *Tetrahedron Lett.*, **27**, 2479 (1986).
268. D. Gentric, J-Y. LeBihan, M-C. Senecha-Torquev, D. Senehal, B. Caro, *Tetrahedron Lett.*, **27**, 3849 (1986).
269. J. Brocand, L. Pelinski, J. Lebib, *J. Organomet. Chem.*, **309**, 299 (1986).
270. J. Brocard, J. Lebib, *J. Organomet. Chem.*, **310**, C63 (1986).
271. A. Solladie-Cavallo, D. Farkhanj, *Tetrahedron Lett.*, **27**, 1331 (1986).
272. R. P. Alexander, G. R. Stephenson, *J. Organomet. Chem.*, **314**, C73 (1986).
273. D. Mandon, D. Astruc, *J. Organomet. Chem.*, **307**, C27 (1986).
274. D. Mandon, L. Toupet, D. Astric, *J. Am. Chem. Soc.*, **108**, 1320 (1986).
275. L. H. T. My, *Diss. Abstr. Int. B.*, **47**, 209 (1986).
276. O. S. Andell, J. E. Backväll, C. Moberg, *Acta Chem. Scand.*, **B40**, 184 (1986).
277. M. Franck-Newumann, D. Martino, M-P. Heitz, *J. Organomet. Chem.*, **301**, 61 (1986).
278. M. Franck-Neumann, D. Martina, M-P. Hertz, *J. Organomet. Chem.*, **315**, 59 (1986).
279. A. J. Pearson, Y-S. Chen, *J. Org. Chem.*, **51**, 1939 (1986).
280. P. A. Grieco, S. D. Larsen, *J. Org. Chem.*, **51**, 3553 (1986).
281. R. P. Alexander, G. R. Stephenson, *J. Organomet. Chem.*, **299**, C1 (1986).
282. A. J. Pearson, J. Yoon, *J. C. S. Chem. Comm.*, 1467 (1986).
283. A. J. Pearson, V. D. Khetani, *J. C. S. Chem. Comm.*, 1772 (1986).
284. G. Salerno, C. Gallo, G. P. Chiasoli, M. Costa, *J. Organomet. Chem.*, **317**, 373 (1986).
285. T-a. Mitsudo, Y. Hori, Y. Watanabe, *Bull. Chem. Soc., Jpn.*, **59**, 3201 (1986).
286. K. Fagami, S. Nakatsukasa, K. Oshima, K. Utimoto, H. Nozaki, *Chem. Lett.*, 869 (1986).
287. M. P. Doyle, *Acct. Chem. Res.*, **19**, 348 (1986).
288. M. P. Doyle, *Chem. Rev.*, **86**, 919 (1986).
289. A. Parlier, H. Rudler, *J. C. S. Chem. Comm.*, 514 (1986).
290. D. Moderhack, *Synthesis*, 1083 (1985).
291. R. C. Cambie, P. S. Rutledge, M. Tercel, P. D. Woodgate, *J. Organomet. Chem.*, **315**, 171 (1986).
292. K. H. Dötz, M. Popall, G. Müller, K. Ackermann, *Angew. Chem. Int. Ed.*, **25**, 911 (1986).
293. A. Yamashita, A. Toy, *Tetrahedron Lett.*, **27**, 3471 (1986).
294. H. T. Huy, P. Lefloch, J. M. Louis, M. Fetizon, *J. Organomet. Chem.*, **311**, 79 (1986).
295. T. M. Sivavec, T. J. Katz, *Gov. Rep. Announce. Index*, **85**, 68 (1985j).

296. K. S. Chen, W. D. Wulff, *J. Am. Chem. Soc.*, **108**, 5229 (1986).
297. A. Yamashita, *Tetrahedron Lett.*, **27**, 5915 (1986).
298. K. H. Dötz, W. Sturm, *J. Organomet. Chem.*, **310**, C22 (1986).
299. W. D. Wulff, S. R. Gilbertson, J. P. Springer, *J. Am. Chem. Soc.*, **108**, 520 (1986).
300. A. Annon, *Nachr. Chem., Tech. Lab.*, **34**, 562 (1986).
301. R. W. Carling, A. B. Holmes, *J. C. S. Chem. Comm.*, 565 (1986).
302. Y. Liu, M. Chen, Y. Li, J. Wang, *Caodeng Xuexiao Huaxue Xuebao*, **6**, 1083 (1985).
303. J. R. Stille, R. H. Grubbs, *J. Am. Chem. Soc.*, **108**, 855 (1986).
304. T. Kauffmann, T. Abel, C. Beirich, G. Kieper, *Tetrahedron Lett.*, **27**, 5355 (1986).
305. T. Kauffmann, R. Abeln, S. Welke, D. Wangbermhühle, *Angew. Chem. Int. Ed.*, **25**, 909 (1986).
306. T. Kauffmann, M. Enk, W. Kaschibe, E. Tolipoulos, D. Wingbermukle, *Angew. Chem. Int. Ed.*, **25**, 910 (1986).
307. S. G. Davies, J. I. Seeman, I. H. Williams, *Tetrahedron Lett.*, **27**, 619 (1986).
308. S. L. Brown, S. G. Davies, D. F. Foster, J. I. Seeman, P. Warner, *Tetrahedron Lett.*, **27**, 623 (1986).
309. S. G. Davies, R. J. C. Easton, A. Gonzalez, S. C. Preston, K. H. Sutton, J. C. Walke, *Tetrahedron*, **42**, 3987 (1986).
310. L. S. Liebeskind, M. E. Welker, R. W. Fengl, *J. Am. Chem. Soc.*, **108**, 6328 (1986).
311. S. G. Davies, I. M. Dordor-Hedgecock, K. H. Sutton, J. C. Walker, *Tetrahedron Lett.*, **27**, 3787 (1986).
312. S. G. Davies, I. M. Dordor-Hedgecock, K. H. Sutton, J. C. Walker, *Tetrahedron*, **42**, 5123 (1986).
313. S. G. Davies, J. C. Walker, *J. C. S., Chem. Comm.*, 495 (1986).
314. M. Akita, A. Kondoh, *J. Organomet. Chem.*, **299**, 369 (1986).
315. P. G. Lenhert, C. M. Lukehart, L. Sacksteder, *J. Am. Chem. Soc.*, **108**, 793 (1986).
316. J. W. Herndon, *J. Org. Chem.*, **51**, 2853 (1986).
317. S. G. Davies, J. C. Walker, *J. C. S. Chem. Comm.*, 609 (1986).
318. S. L. Brown, S. G. Davies, *J. C. S. Chem. Comm.*, 84 (1986).
319. C. H. Heathcock, J. J. Doney, R. G. Bergman, *Pure Appl. Chem.*, **57**, 1789 (1985).
320. C. A. Rusik, T. L. Tonker, J. L. Templeton, *J. Am. Chem. Soc.*, **108**, 4652 (1986).
321. A. Lichtman, *Diss. Abstr. Int. B.*, **47**, 209 (1986).
322. T. Tanaka, N. Okamura, K. Bannai, A. Hayato, S. Sugura, K. Tomimori, K. Manabe, S. Kurozumi, *Tetrahedron*, **42**, 6747 (1986).
323. Y. Hatanaka, I. Kuwajima, *J. Org. Chem.*, **51**, 1932 (1986).
324. M. Shibasaki, T. Mase, S. Ikegami, *J. Am. Chem. Soc.*, **108**, 2019 (1986).
325. J. A. Marshall, J. E. Audia, B. G. Shearer, *J. Org. Chem.*, **51**, 1730 (1986).
326. G. Hallnemo, C. Ullenius, *Tetrahedron Lett.*, **27**, 395 (1986).
327. M. Behforonz, T. T. Curran, J. L. Bolan, *Tetrahedron Lett.*, **27**, 3107 (1986).

- 328a. Y. Horiguchi, S. Matsuzawa, E. Nakamura, I. Kuwajima, *Tetrahedron Lett.*, **27**, 4025 (1986).
- 328b. *idem. ibid*, **27**, 4029 (1986).
329. A. Alexakis, J. Berlan, Y. Besace, *Tetrahedron Lett.*, **27**, 1047 (1986).
330. R. J. Linderman, A. Godfrey, *Tetrahedron Lett.*, **27**, 4553 (1986).
331. J. Berlan, Y. Besace, G. Pourcelot, P. Cresson, *Tetrahedron*, **42**, 4757 (1986).
332. J. Berlan, Y. Besace, *Tetrahedron*, **42**, 4767 (1986).
333. A. Bernardi, S. Cardani, G. Poli, C. Scolastico, *J. Org. Chem.*, **51**, 5043 (1986).
334. K. Tamioka, T. Suenaga, K. Koga, *Tetrahedron Lett.*, **27**, 369 (1986).
335. S. G. Pyne, *Tetrahedron Lett.*, **27**, 1691 (1986).
336. S. G. Pyne, *J. Org. Chem.*, **51**, 81 (1986).
337. T. Pbuka, T. Nakao, S. Nishii, Y. Yamamoto, *J. Am. Chem. Soc.*, **108**, 7420 (1986).
338. P. Mangenez, A. Alexakis, J. F. Normant, *Tetrahedron Lett.*, **27**, 3143 (1986).
339. W. Oppolzer, T. Stevenson, *Tetrahedron Lett.*, **27**, 1139 (1986).
340. W. Oppolzer, P. Schneider, *Helv. Chim. Acta*, **69**, 1817 (1986).
341. W. Oppolzer, R. Moretti, G. Bernardelli, *Tetrahedron Lett.*, **27**, 4713 (1986).
342. S. H. Bertz, G. Dabbagh, G. Sundararajan, *J. Org. Chem.*, **51**, 4953 (1986).
343. E. J. Corey, R. Naef, F. J. Hannon, *J. Am. Chem. Soc.*, **108**, 7114 (1986).
344. S. Andersson, S. Jagner, M. Nilsson, F. Urso, *J. Organomet. Chem.*, **301**, 257 (1986).
345. A. Alberola, A. M. Gonzalez, M. A. Laguna, F. J. Pulido, *Synth. Comm.*, **16**, 673 (1986).
346. V. Calo, L. Lopez, G. Pesche, *J. C. S. Chem. Comm.*, 1252 (1986).
347. T. Ibuka, T. Aoyagi, Y. Yamamoto, *Chem. Pharm. Bull.*, **34**, 2417 (1986).
348. R. K. Dieter, L. A. Silks III, *J. Org. Chem.*, **51**, 4687 (1986).
349. D. K. Hutchinson, S. A. Hardinger, P. L. Fuchs, *Tetrahedron Lett.*, **27**, 1425 (1986).
350. D. K. Hutchinson, P. L. Fuchs, *Tetrahedron Lett.*, **27**, 1429 (1986).
351. T. Tsuda, T. Hayashi, H. Satomi, T. Kawamoto, T. Saegusa, *J. Org. Chem.*, **51**, 537 (1986).
352. E. Keinan, N. Greenspoon, *J. Am. Chem. Soc.*, **108**, 7314 (1986).
353. A. B. Smith, P. A. Levenberg, J. Z. Suits, *Synthesis*, 184 (1986).
354. M. Nitta, H. Miyano, *J. C. S. , Perkin I*, 595 (1986).
355. A. Sen, *Proc. Indian Assoc. Cultiv. Sci.*, **68B**, 1 (1985).
356. L. Marko, *J. Organomet. Chem.*, **305**, 333 (1986).
357. H. des Abbayes, *Israel J. Chem.*, **26**, 249 (1986).
358. H. Alper, *J. Organomet. Chem.*, **300**, 1 (1986).
359. A. M. Trzeciak, *Wiad. Chem.*, **39**, 629 (1985).

360. D. Banach, G. O. Evans, D. G. McIntyre, T. Predmore, M. G. Richmond, J. H. Supple, R. P. Stewart, Jr., *J. Mol. Catal.*, **31**, 15 (1985).
361. M. Hidai, A. Fukuoka, Y. Koyasu, Y. Uchida, *J. Mol. Catal.*, **35**, 29 (1986).
362. L. L. Troitskaya, V. I. Sokolov, *J. Organomet. Chem.*, **285**, 389 (1985).
363. J. K. Stille, *Chem. Ind.*, **22**, 23 (1985).
364. S. D. Burke, J. E. Cobb, *Tetrahedron Lett.*, **27**, 4237 (1986).
365. V. A. Rybakov, *Neftekhimiya*, 84 (1985).
366. A. D. Karpyuk, E. S. Petrov, I. P. Beletskaya, *Izv. Akad. Nauk SSSR, Ser. Khim.*, 1134 (1986).
367. G. Cavinato, L. Toniolo, C. Botteghi, *J. Mol. Catal.*, **32**, 211 (1985).
368. A. V. Protchenko, T. E. Kron, A. D. Karpyuk, E. S. Petrov, E. N. Tsvetkov, I. P. Beletskaya, *Zh. Obshch. Khim.*, **56**, 90 (1986).
369. A. D. Karpyuk, L. F. Starosel'skaya, E. S. Petrov, I. P. Beletskaya, *Izv. Akad. Nauk SSSR, Ser. Khim.*, 218 (1986).
370. S. B. Fergusson, H. Alper, *J. Mol. Catal.*, **34**, 381 (1986).
371. M. G. Vinogradov, A. B. Tuzikov, G. I. Nikishin, *Izv. Akad. Nauk SSSR, Ser. Khim.*, 2557 (1985).
372. K. Doyama, T. Joh, S. Takahashi, *Tetrahedron Lett.*, **27**, 4497 (1986).
373. E. Amari, M. Catellani, G. P. Chiusoli, *Chim. Ind. (Milan)*, **68**, 51 (1986).
374. P. E. Fanwick, L. M. Kobriger, A. K. McMullen, I. P. Rothwell, *J. Am. Chem. Soc.*, **108**, 8095 (1986).
375. J. D. Meinhardt, B. D. Santarsiero, R. H. Grubbs, *J. Am. Chem. Soc.*, **108**, 3318 (1986).
376. T. W. Bodnar, E. J. Crawford, A. R. Cutler, *Organomet.*, **5**, 947 (1986).
377. P. Eilbracht, R. Jelitte, P. Trabold, *Chem. Ber.*, **119**, 169 (1986).
378. M. Franck-Neumann, M. Sedrati, M. Mokhi, *Angew. Chem. Int. Ed.*, **25**, 1131 (1986).
379. G. M. Williams, D. E. Rudisill, *Tetrahedron Lett.*, **27**, 3465 (1986).
380. E. P. Bakalova, V. V. Chenets, A. D. Gnilit'skaya, F. K. Shmidt, *Kinet. Katal.*, **26**, 1091 (1985).
381. V. Baillargeon, *Diss. Abstr. Int. B.*, **46**, 3443 (1986).
382. V. P. Baillargeon, J. K. Stille, *J. Am. Chem. Soc.*, **108**, 452 (1986).
383. R. Takeuchi, Y. Tsuji, Y. Watanabe, *J. C. S. Chem. Comm.*, 351 (1986).
384. C. B. Ou, L. K. Liu, *J. Chin. Chem. Soc. (Taipei)*, **32**, 23 (1985).
385. P. Laurent, G. Tangunz, H. des Abbayes, *J. C. S. Chem. Comm.*, 1755 (1986).
386. M. Miura, F. Akase, M. Nomura, *J. C. S. Chem. Comm.*, 241 (1986).
387. T. Kashimura, K. Kudo, S. Mori, N. Sugita, *Chem. Lett.*, 483 (1986).
388. T. Kashimura, K. Kudo, S. Mori, N. Sugita, *Chem. Lett.*, 851 (1986j).
389. B. Morin, A. Hirschauer, F. Hugues, *J. Mol. Catal.*, **34**, 317 (1986).
390. B. Fell, H. Chrobaczek, W. Kohl, *Chem.-Ztg.*, **109**, 167 (1985).

391. F. Francalanci, E. Bencini, A. Gardano, M. Vincenti, F. Foa, *J. Organomet. Chem.*, **301**, C27 (1986).
392. F. Ozawa, H. Yanagihara, A. Yamamoto, *J. Org. Chem.*, **51**, 415 (1986).
393. D. Milstein, *J. C. S. Chem. Comm.*, 817 (1986).
394. L. S. Hegedus, M. S. Holden, *J. Org. Chem.*, **51**, 1171 (1986).
395. E-i. Negishi, J. M. Tour, *Tetrahedron Lett.*, **27**, 4869 (1986).
396. T-a. Kobayashi, M Tanaka, *Tetrahedron Lett.*, **27**, 4745 (1986).
397. Y. Wakita, T. Yasunaga, M. Akita, M. Kojima, *J. Organomet. Chem.*, **301**, C17 (1986).
398. M. Tanaka, T. Kobayashi, T. Sakakura, *Nippon Kagaku Kaishi*, 537 (1985).
399. M. Franck-Neumann, M. Sediati, M. Mokhi, *Tetrahedron Lett.*, **27**, 3861 (1986).
400. T. Hirao, Y. Harano, Y. Yamana, Y. Hamada, S. Nagata, T. Agawa, *Bull. Chem. Soc., Jpn.*, **59**, 1341 (1986).
401. A. Miyashita, T. Kihara, K. Nomura, H. Nohira, *Chem. Lett.*, 1607 (1986).
402. S. Cacchi, P. G. Ciattini, E. Morera, G. Ortar, *Tetrahedron Lett.*, **27**, 3931 (1986).
403. Y. Tsuji, T. Ohsumi, T. Kondo, Y. Watanabe, *J. Organomet. Chem.*, **309**, 333 (1986).
404. V. I. Manov-Yuvenskii, A. L. Lapidus, K. B. Petrovskii, *Izv. Akad. Nauk SSSR, Ser. Khim*, 1709 (1985).
405. H. Tietz, K. Schwetlick, G. Kreisel, *Z. Chem.*, **25**, 290 (1985).
406. K. Unverferth, H. Tietz, K. Schwetlick, *J. Prakt. Chem.*, **327**, 932 (1985).
407. S. Antebi, H. Alper, *Can. J. Chem.*, **64**, 2010 (1986).
408. S. S. Yuan, Am. Ajami, *J. Organomet. Chem.*, **302**, 255 (1986).
409. F. Ozawa, M. Nakano, I. Aoyama, T. Yamamoto, A. Yamamoto, *J. C. S. Chem. Comm.*, 382 (1986).
410. G. Jenner, Y. Chreim, *J. Mol. Cat.*, **33**, 259 (1985).
411. G. Bitsi, G. Jenner, *Appl. Catal.*, **21**, 201 (1986).
412. N. Chatani, S. Fuji, Y. Yamasaki, S. Murai, N. Sonoda, *J. Am. Chem. Soc.*, **108**, 7361 (1986).
413. R. Jaouhari, P. H. Dixneuf, S. Lecolier, *Tetrahedron Lett.*, **27**, 6315 (1986).
414. G. Braca, A. M. Raspolli Galletti, G. Sbrana, F. Zanni, *J. Mol. Catal.*, **34**, 183 (1986).
415. R. Bartek, M. M. Habib, W. R. Pretzer, *J. Mol. Catal.*, **33**, 245 (1985).
416. M. Leconte, A. Theolier, D. Rojas, A. Choplin, J. M. Basset, *Int. Congr. Catal.*, **2** (1985).
417. K. J. Jung, P. Lejembre, A. Gaset, P. Kalck, Y. Maire, *Bull. Soc. Chim. Fr.*, 459 (1986).
418. K. Hori, M. Ando, N. Takaishi, *Tetrahedron Lett.*, **27**, 4615 (1986).
419. S-i. Murahashi, T. Naota, N. Nakajima, *J. Org. Chem.*, **51**, 898 (1986).
420. A. Behr, *Bull. Soc. Chim. Belg.*, **94**, 671 (1985).

421. S. Torii, H. Tanaka, T. Hamatani, K. Morisaki, A. Jutland, F. Pfluger, J-F. Fauvarque, *Chem. Lett.*, 169 (1986).
422. Y. Morimoto, Y. Fujiwara, H. Taniguchi, Y. Hori, Y. Nagano, *Tetrahedron Lett.*, **27**, 1809 (1986).
423. T. Kashimura, K. Kudo, S. Mori, N. Sugita, *Chem. Lett.*, 299 (1986).
424. Y. Sasaki, *Tetrahedron Lett.*, **27**, 1573 (1986).
425. R. Make, P. H. Dixneuf, S. Lecolier, *Tetrahedron Lett.*, **27**, 6333 (1986).
426. Y. Sasaki, P. H. Dixneuf, *J. C. S. Chem. Comm.*, 790 (1986).
427. A. Behro, G. Thelen, *C<sub>7</sub> Mol. Chem.*, **1**, 137 (1984).
428. H. Hoberg, Y. Peres, A. Milchereut, *J. Organomet. Chem.*, **307**, C38 (1986).
429. H. Hoberg, Y. Peres, A. Milchereut, *J. Organomet. Chem.*, **307**, C41 (1986).
430. R. Neidlein, A. Rufinska, H. Schwager, G. Wilke, *Angew. Chem. Int. Ed.*, **25**, 640 (1986).
431. E. Carmona, P. Palma, M. Paneque, M. L. Poveda, E. Gutierrez-Puebla, A. Monge, *J. Am. Chem. Soc.*, **108**, 6424 (1986).
432. A. Behr, U. Kanne, *J. Organomet. Chem.*, **317**, C41 (1986).
433. A. Behr, R. He, K. D. Juszak, C. Krueger, Y. H. Tsay, *Chem. Ber.*, **119**, 991 (1986).
434. H. Hoberg, K. Jenni, C. Krüger, E. Raabe, *Angew. Chem. Int. Ed.*, **25**, 810 (1986).
435. J. Tsuji, T. Sugiura, M. Yuhara, I. Minami, *J. C. S. Chem. Comm.* 922 (1986).
436. I. Minami, M. Yuhara, I. Shimizu, J. Tsuji, *J. C. S. Chem. Comm.*, 118 (1986).
437. S. Muthukmaru Pillai, M. Raurindranathan, S. Sivarain, *Chem. Ber.*, **86**, 239 (1986).
438. R. F. Jordan, C. S. Bajgur, R. Willett, B. Scott, *J. Am. Chem. Soc.*, **108**, 7410 (1986).
439. L. N. Russyan, V. D. Litvinova, P. E. Matkovskii, Kh.-M. A. Brikenstein, *Neftekhimiya*, **25**, 773 (1985).
440. J. R. Sohn, H. J. Kim, *J. Catal.*, **101**, 428 (1986).
441. J-P. Gehrke, R. Taube, E. Balbolov, K. Kurtev, *J. Organomet. Chem.*, **304**, C4 (1986).
442. V. A. Kabanov, G. A. Grishin, M. A. Martynova, A. I. Prudnikov, L. M. Rozenberg, *Kinet. Katal.*, **26**, 1427 (1985).
443. D. L. Beach, J. E. Bozik, C. Y. Wu, Y. V. Kissin, *J. Mol. Catal.*, **34**, 345 (1986).
444. V. N. Mel'nikov, P. E. Matkovskii, V. N. Belova, P. S. chekrii, Kh. M. Brikenstein, O. A. Sycheva, *Neftekhimiya*, **25**, 486 (1985).
445. Z. Gao, G. Wang, K. Zhou, *Cuihua Xuebao*, **6**, 390 (1985).
446. A. G. Azizov, Kh. Z. Mamedov, S. M. Aliev, *Neftekhimiya*, **25**, 780 (1985).
447. P. Binger, A. Brinkmann, P. Wedemann, *Chem. Ber.*, **119**, 3089 (1986).
448. G. Salerno, F. Gigliotti, C. P. Chiusoli, *J. Organomet. Chem.*, **314**, 231 (1986).
449. M. Aresta, E. Quaranta, A. Ciccacese, *C<sub>7</sub> Mol. Chem.*, **1**, 283 (1985).

450. G. P. Potapov, V. V. Puneegov, U. M. Dzhemilev, *Izv. Akad. Nauk SSSR, Ser. Khim.*, 1468 (1985).
451. D. E. Bergbreiter, R. Chandian, *J. Org. Chem.*, **51**, 4754 (1986).
452. R. V. Kunakova, V. V. Sidorova, U. M. Dzhemilev, *Izv. Akad. Nauk SSSR, Ser. Khim.*, 2624 (1985).
453. R. Berger, L. Klimke, *Z. Chem.*, **25**, 226 (1985).
454. L. Y. Gubaidullin, E. I. Logunov, V. P. Yur'ev, *Zh. Org. Khim.*, **21**, 1131 (1985).
455. A. Citterio, P. de Angelis, P. Longo, A. Musco, *J. Chem. Res.*, 316 (1985).
456. P. W. Jolly, R. Nymott, B. Raspel, K-P. Schick, *Organometallics*, **5**, 473 (1986).
457. A. Behr, U. Kanne, *J. Organomet. Chem.*, **309**, 215 (1986).
458. M. J. Winter, *Chem. Met.-Carbon Bond*, **3**, 259 (1985).
459. J. R. Fritch, K. P. C. Vollhardt, *Israel J. Chem.*, **26**, 131 (1986).
460. N. Satyanarayana, M. Periasany, *Tetrahedron Lett.*, **27**, 6253 (1986).
461. M. Furker, R. J. K. Taylor, S. C. Burford, *J. C. S. Perkin I*, 1809 (1986).
462. K. Mach, T. Turecek, H. Antropinsova, V. Hanus, *Organometallics.*, **5**, 1215 (1986).
463. Y. Huang, J. Zhou, Z. Zhu, J. Li, *J. Fluorine Chem.*, **30**, 455 (1986).
464. K. Abdulla, B. L. Booth, C. Stacey, *J. Organomet. Chem.*, **293**, 103 (1985).
465. W. Schulz, U. Rosenthal, *Z. Chem.*, **26**, 176 (1986).
466. A. Mantovani, A. Marcomini, U. Belluco, *J. Mol. Catal.*, **30**, 73 (1985).
467. D. Walther, D. Braun, B. Undeutsch, *Z. Chem.*, **26**, 175 (1986).
468. J. J. Eisch, J. E. Galle, A. A. Aradi, M. P. Boleslawski, *J. Organomet. Chem.*, **312**, 399 (1986).
469. C-a. Chang, *Diss. Abstr. Int. B.*, **46**, 1167 (1985).
470. H. Butenschon, M. Winkler, K. P. C. Vollhardt, *J. C. S. Chem. Comm.*, 388 (1986).
471. S. H. Lecher, N. H. Nguyen, K. P. C. Vollhardt, *J. Am. Chem. Soc.*, **108**, 856 (1986).
472. D. B. Grotjahn, K. P. C. Vollhardt, *J. Am. Chem. Soc.*, **108**, 2091 (1986).
473. G. S. Sheppard, K. P. C. Vollhardt, *J. Org. Chem.*, **51**, 5498 (1986).
474. R. J. McKinney, *Organometallics*, **5**, 1752 (1986).
475. T. Ueda, Y. Otsuji, *Chem. Lett.*, 1631 (1986).
476. T. Ueda, Y. Otsuji, *Chem. Lett.*, 1635 (1986).
477. A. P. Marchand, A. D. Earlywine, M. J. Heeg, *J. Org. Chem.*, **51**, 4096 (1986).
478. H. Kanai, Y. Watanabe, T. Nakayama, *Bull. Chem. Soc., Jpn*, **59**, 1277 (1986).
479. M. Iyoda, H. Otani, M. Oda, Y. Kai, Y. Baba, N. Kasai, *J. C. S. Chem. Comm.*, 1795 (1986).
480. D. C. J. Kramer, R. J. M. Nolte, W. Drenthe, *J. C. S. Chem. Comm.*, 1789 (1986).
481. R. R. Schrock, *J. Organomet. Chem.*, **300**, 249 (1986).
482. J. Ogonowski, *Chemik*, **37**, 341 (1984).
483. H. Liu, *Huaxue Tongbao*, **7** (1985).



484. C. P. Parnell, *Diss. Abstr. Int. B.*, **46**, 837 (1985).
485. H. Liu, *Yingyong Huaxue*, **3**, 1 (1986).
486. A. Y. Yuffa, L. I. Vershinina, D. B. Furman, O. V. Bragin, *Neftekhimiya*, **25**, 495 (1985).
487. J. Engelhardt, D. Kallo, *Acta Chim. Hung.*, **119**, 249 (1985).
488. M. Berglund, C. Andersson, R. Larsson, *J. Organomet. Chem.*, **314**, 61 (1986).
489. B. Marciniac, *Organosilicon Bioorganosilicon Chem.*, 183 (1985).
490. L. R. Gilliom, R. H. Grubbs, *J. Am. Chem. Soc.*, **108**, 733 (1986).
491. K. Weiss, *Angew. Chem. Int. Ed.*, **25**, 358 (1986).
492. C. J. Schaverien, J. C. Dewan, R. R. Schrock, *J. Am. Chem. Soc.*, **108**, 2771 (1986).
493. L. R. Gilliom, R. H. Grubbs, *Organomet.*, **5**, 721 (1986).
494. Y. Liu, M. Chen, J. Wang, *Huaxue Xuebao*, **43**, 539 (1985).
495. H. Kanai, S. B. Choe, K. J. Klabunde, *J. Am. Chem. Soc.*, **108**, 2019 (1986).
496. I. Matsuda, T. Kato, S. Sato, Y. Izumi, *Tetrahedron Lett.*, **27**, 5747 (1986).
497. A. Basu, S. Bhaduri, K. R. Sharma, *Adv. Catal.*, 669 (1985).
498. Q. Yanlong, L. Jiaque, X. Weihua, *J. Mol. Catal.*, **34**, 31 (1986).
499. W. Xu, Y. Qian, J. Zhuang, *Cuihua Xuebao*, **6**, 267 (1985).
500. Y. L. Chow, H. Li, *Can. J. Chem.*, **64**, 2229 (1986).
501. J. Rodriguez, P. Brun, B. Waegell, *Tetrahedron Lett.*, **27**, 835 (1986).
502. X. Lu, L. Zhang, Z. Lin, *Youji Huaxue*, 217 (1985).
503. H. P. Frauenrath, *Angew. Chem.*, **98**, 261 (1986).
504. K. Tani, *Pure Appl. Chem.*, **57**, 1845 (1985).
505. S. Otsuka, K. Tani, *Asymmetric Synth.*, **5**, 171 (1985).
506. T. Bieg, W. Szeja, *J. Carbohydr. Chem.*, **4**, 441 (1985).
507. R. A. Sanchez-Delgado, A. Andriollo, E. Gonzalez, N. Valencia, V. Leon, J. Espidel, *J. Chem. Soc., Dalton Trans.*, 1859 (1985).
508. J. L. van der Baan, F. Bickelhaupt, *Tetrahedron Lett.*, **27**, 6267 (1986).
509. X. Lu, J. Zhu, *J. Organomet. Chem.*, **304**, 239 (1986).
510. K. Hiroi, K. Makino, *Chem. Lett.*, 617 (1986).
511. K. Hiroi, K. Suya, S. Sato, *J. C. S. Chem. Comm.*, 469 (1986).
512. P. R. Auburn, J. Whelan, B. Bosnich, *J. C. S. Chem. Comm.*, 146 (1986).
513. I. Minami, M. Yamada, J. Tsuji, *Tetrahedron Lett.*, **27**, 1805 (1986).
514. J. Tsuji, M. Nisar, I. Minami, *Tetrahedron Lett.*, **27**, 2483 (1986).
515. J. Tsuji, T. Sugura, I. Minami, *Tetrahedron Lett.*, **27**, 731 (1986).
516. M. Uchikawa, T. Hanamoto, T. Katsuki, M. Yamaguchi, *Tetrahedron Lett.*, **27**, 4577 (1986).
517. M. Uchikawa, S. Kuroda, T. Katsuki, M. Yamaguchi, *Tennen Yuki Kagobutsu Toronkai Koen Yoshishu*, 62 (1985).
518. M. Uchikawa, T. Katsuki, M. Yamaguchi, *Tetrahedron Lett.*, **27**, 4581 (1986).

519. H. Zimmer, Z. Paal, *Int. Congr. Catal.*, **3** (1984).
520. A. Sarkany, *J. Catal.*, **97**, 407 (1986).
521. Y. Stenstrom, W. M. Jones, *Organometallics*, **5**, 178 (1986).
522. M. Parra-Hake, *Organometallics*, **5**, 1032 (1986).
523. D. DiFrancesco, A. R. Pinhas, *J. Org. Chem.*, **51**, 2098 (1986).
524. S. Miki, S-i. Matsumura, T. Ohno, Z-i. Yoshida, *Tetrahedron Lett.*, **27**, 3669 (1986).
525. K. Maruyama, H. Tamiaki, *J. Org. Chem.*, **51**, 602 (1986).
526. P. Berno, A. Cecion, F. Dapra, A. Gambaro, A. Venzo, P. Ganis, G. Valle, *J. Organomet. Chem.*, **301**, 161 (1986).
527. A. Tantivanich, D. Supatimusro, *Tetrahedron Lett.*, **27**, 5301 (1986).
528. K. Saito, *Heterocycles*, **24**, 1831 (1986).
529. M. Nitta, H. Miyano, *Heterocycles*, **24**, 1411 (1986).
530. M. Nitta, H. Miyano, T. Kobayashi, *Heterocycles*, **24**, 77 (1986).
531. T. Tenase, F. Shimizu, S. Yano, S. Yoshikawa, *J. C. S. Chem. Comm.*, 1001 (1986).
532. Y. D. Vankar, N. C. Chandhuri, S. P. Singh, *Synth. Comm.*, **16**, 1621 (1986).
533. Y. D. Vankar, S. P. Singh, *Chem. Lett.*, 1939 (1986).
534. K. Maruoka, M. Hasegawa, H. Yamamoto, *J. Am. Chem. Soc.*, **108**, 3827 (1986).
535. A. Miyashita, T. Shimada, A. Sugawara, H. Nohira, *Chem. Lett.*, 1323 (1986).
536. G. Meyer, Y. Rollin, J. Perichon, *Tetrahedron Lett.*, **27**, 3497 (1986).
537. H. Suzuki, A. Kondo, M. Inouye, T. Ogawa, *Synthesis*, 121 (1986).
538. R. Davis, N. M. S. Khazaal, V. Maistry, *J. C. S. Chem. Comm.*, 1387 (1986).
539. H. Yonemura, H. Nishino, K. Kurosawa, *Bull. Chem. Soc., Jpn.*, **59**, 3153 (1986).
540. W. D. Wulff, G. A. Peterson, W. E. Bauta, K-S. Chan, K. L. Faron, S. R. Gilbertson, R. W. Kaesler, D. C. Yang, C. K. Murray, *J. Org. Chem.*, **51**, 277 (1986).
541. S. E. Drewes, B. J. Slater-Kinghorn, *Syn. Comm.*, **16**, 603 (1986).
542. J. A. Ciaccio, K. J. Address, T. W. Bell, *Tetrahedron Lett.*, **27**, 3697 (1986).
543. H. Hoberg, E. Hernandez, *J. Organomet. Chem.*, **311**, 307 (1986).
544. H. Hoberg, E. Hernandez, *J. C. S. Chem. Comm.*, 544 (1986).
545. G. Süß-Fink, G. Hermann, *Angew. Chem. Int. Ed.*, **25**, 570 (1986).
546. K-i. Tanaka, S. Yoshifuji, Y. Nitta, *Chem. Pharm. Bull.*, **34**, 3879 (1986).
547. S-i. Murahashi, T. Naota, E. Saito, *J. Am. Chem. Soc.*, **108**, 7846 (1986).
548. T. F. Rakhimova, A. O. Litinskii, G. I. Nikishin, V. G. Glukhovtsev, *Izv. Vyssh. Uchebn. Zaved., Khim. Khim. Tekhnol.*, **29**, 38 (1986).
549. W. R. Jackson, P. Perlmutter, *Chem. Br.*, **22**, 338 (1986).
550. C. A. Tolman, R. J. McKinney, W. C. Seidel, J. D. Druliner, W. R. Stevens, *Adv. Catal.*, **33**, 1 (1985).
551. W. R. Jackson, P. Perlmutter, P. S. Elmes, C. G. Lovel, R. J. Thompson, D. Haarbarger, M. K. S. Probert, A. J. Smallridge, E. M. Campi, *Org. Synth. Interdiscip. Challenge Proc IUPAC Symp. 5th*, 55 (1984).

552. J. E. Bäckvall, O. S. Andell, *Organomet.*, **5**, 2350 (1986).
553. N. Chatani, T. Hanafusa, *J. Org. Chem.*, **51**, 4714 (1986).
554. A. Nose, T. Kudo, *Chem. Pharm. Bull.*, **34**, 3905 (1986).
555. J. A. Cowan, *Tetrahedron Lett.*, **27**, 1205 (1986).
556. P. Khandual, P. K. Santra, C. R. Saha, *Proc. Indian Nat'l. Sci. Acad., Part A*, **51**, 538 (1985).
557. R. S. Varma, M. K. Varma, G. W. Kabalka, *Synth. Commun.*, **16**, 91 (1986).
558. G. I. Korenyako, O. M. Negomedzyanova, K. V. Kotegov, V. M. Belousov, *Katal. Katal.*, **22**, 98 (1984).
559. M. Kosugi, T. Ogata, H. Tamura, H. Sano, T. Migita, *Chem. Lett.*, 1197 (1986).
560. Y. Tsuji, R. Takeguchi, H. Ogawa, Y. Watanabe, *Chem. Lett.*, 293 (1986).
561. S-i. Murahashi, Y. Tamigawa, Y. Imada, Y. Taniguchi, *Tetrahedron Lett.*, **27**, 227 (1986).
562. R. W. Armbruster, M. M. Morgan, J. L. Schmidt, C. M. Lau, R. M. Riley, D. Zabroaskii, H. Dieck, *Organometallics*, **5**, 234 (1986).
563. M. Kosugi, M. Kameyama, H. Sano, T. Migita, *Nippon Kagaku Kaishi*, 547 (1985).
564. K. Yoshida, M. Yamamoto, M. Ishiguro, *Chem. Lett.*, 1059 (1986).
565. C. Blandy, D. Gervais, M. S. Cardenas, *J. Mol. Catal.*, **34**, 39 (1986).
566. J. Muzart, *Bull. Soc. Chim., Fr.*, 65 (1986).
567. R. Gamboni, C. Tamm, *Tetrahedron Lett.*, **27**, 3999 (1986).
568. Y. Morizawa, A. Yasuda, K. Uchida, *Tetrahedron Lett.*, **27**, 1833 (1986).
569. G. J. McGarvey, M. Kimura, *J. Org. Chem.*, **51**, 3915 (1986).
570. M. Tokles, J. K. Snyder, *Tetrahedron Lett.*, **27**, 3951 (1986).
571. T. Yamada, K. Narasaka, *Chem. Lett.*, 131 (1986).
572. Y. Ishii, T. Nakano, A. Inada, Y. Kichigami, K. Sakaurai, M. Ogawa, *J. Org. Chem.*, **51**, 240 (1986).
573. H. A. Zahalka, H. Alper, Y. Sasson, *Organomet.*, **5**, 2497 (1986).
574. I. Shimizu, M. Oshima, M. Nisar, J. Tsuji, *Chem. Lett.*, 1775 (1986).
575. Y. Ohkatsu, M. Ohno, T. Ooi, S. Inoue, *Nippon Kagaku Kaishi*, **3**, 387 (1985).
576. M. Rosenblum, M. M. Twinbull, B. M. Foxman, *Organomet.*, **5**, 1062 (1986).
577. T. Murai, K. Furuta, S. Kato, S. Murai, N. Sonoda, *J. Organomet. Chem.*, **302**, 249 (1986).
578. L. Y. Gubaidullin, E. I. Logunov, L. M. L'vovich, V. P. Yur'ev, *Zh. Obshch. Khim.*, **55**, 1554 (1985).
579. N. Narasimhamurthy, A. G. Samuelson, *Tetrahedron Lett.*, **27**, 991 (1986).
580. R. B. Gammill, S. A. Nash, *J. Org. Chem.*, **51**, 3117 (1986).
581. A. J. Pearson, P. R. Bruhn, S.y. Hsu, *J. Org. Chem.*, **51**, 2137 (1986).
582. M. Sakaitani, N. Kurokawa, Y. Ohfune, *Tetrahedron Lett.*, **27**, 3753 (1986).
583. H. Tanaka, H. Urata, T. Fuchikami, *Tetrahedron Lett.*, **27**, 3165 (1986).
584. C. J. Easton, S. G. Love, *Tetrahedron Lett.*, **27**, 2315 (1986).

585. R. DiCosimo, H-C. Szabo, *J. Org. Chem.*, **51**, 1365 (1986).
586. C. Ruppin, P. H. Dixneuf, *Tetrahedron Lett.*, **27**, 6323 (1986).
587. T-a. Mitsudo, Y. Hori, Y. Yamakawa, Y. Watanabe, *Tetrahedron Lett.*, **27**, 2125 (1986).
588. Y. Hayashi, T. Yamamoto, A. Yamamoto, S. Komiya, Y. Kushi, *J. Am. Chem. Soc.*, **108**, 385 (1986).
589. S. Yoshifuji, Y. Arakawa, Y. Nitta, *Chem. Pharm. Bull.*, **33**, 5042 (1985).
590. O. Toussaint, P. Capdevielle, M. Maumy, *Synthesis*, 1029 (1986).
591. L. S. Hegedus, *Org. Synth.: Interdiscip. Challenge, Proc. IUPAC Symp.*, 5th, 17 (1985).
592. P. J. Bonk, *Diss. Abstr. Int. B.*, **47**, 1057 (1986).
593. T. Katsuki, *Gendai Kagaku*, **177**, 44 (1985).
594. K. B. Sharpless, *Chem. Br.*, **22**, 38 (1986).
- 595a. M. G. Finn, K. B. Sharpless, *Asymmetric Synth.*, **5**, 247 (1985).
- 595b. A. Pfenniger, *Synthesis*, 89 (1986).
596. B. E. Rossiter, *Chem. Ind.*, **22**, 295 (1985).
597. R. M. Hanson, K. B. Sharpless, *J. Org. Chem.*, **51**, 1922 (1986).
598. F. Kong, *Huaxue Tongbao*, 35 (1985).
599. J-N. Denis, A. E. Greene, A. Aarao, M-J. Luche, *J. Org. Chem.*, **51**, 46 (1986).
600. T. J. Erickson, *J. Org. Chem.*, **51**, 934 (1986).
601. P. C. Bulman-Page, C. M. Rayner, I. O. Sutherland, *J. Chem. Soc., Chem. Commun.*, 1408 (1986).
602. J. M. Klunder, S. Y. Ko, K. B. Sharpless, *J. Org. Chem.*, **51**, 3710 (1986).
603. R. E. Babin, *Tetrahedron Lett.*, **27**, 5791 (1986).
604. V. G. Dryuk, *Russ. Chem. Rev.*, **54**, 986 (1985).
605. W. Adam, A. Griesbeck, E. Staab, *Angew. Chem.*, **98**, 279 (1986).
606. D. Hoppe, J. Lussmann, P. G. Jones, D. Schmidt, G. M. Sheldrick, *Tetrahedron Lett.*, **27**, 3591 (1986).
607. H. Mimoun, M. Mignard, P. Brechot, L. Sausaine, *J. Am. Chem. Soc.*, **108**, 3711 (1986).
608. J. Prandi, H. B. Kagan, H. Mimoun, *Tetrahedron Lett.*, **27**, 2617 (1986).
609. D. Prat, R. Lett, *Tetrahedron Lett.*, **27**, 707 (1986).
610. D. Prat, B. Delpéch, R. Lett, *Tetrahedron Lett.*, **27**, 711 (1986).
611. E. Dalcanabe, M. Foa, *Synthesis*, 492 (1986).
612. C. L. Hill, R. B. Brown, Jr., *J. Am. Chem. Soc.*, **108**, 536 (1986).
613. K. Srinivasan, P. Michaud, J. K. Kochi, *J. Am. Chem. Soc.*, **108**, 2309 (1986).
614. S. Takagai, E. Takahashi, T. Miyamoto, Y. Sasaki, *Chem. Lett.*, 1275 (1986).
615. C. M. Che, W-K. Cheng, *J. Chem. Soc., Chem. Commun.*, 1443 (1986).
616. A. Miyashita, J-Y. Ishida, H. Nohira, *Tetrahedron Lett.*, **27**, 2127 (1986).

617. M. G. Vinogradov, I. P. Kovalev, G. I. Nikishin, *Izv. Akad. Nauk SSSR, Ser. Khim.*, **2269** (1985).
618. J. C. Dobson, W. K. Seok, T. J. Meyer, *Inorg. Chem.*, **25**, 1513 (1986).
619. D. K. Dutta, R. C. Boruah, J. S. Sandhu, *Heterocycles*, **24**, 655 (1986).
620. A. G. M. Barrett, M. A. Sturgess, *Tetrahedron Lett.*, **27**, 3811 (1986).
621. W. P. Fehlhammer, P. Hirschmann, A. Voelkl, *J. Organomet. Chem.*, **294**, 251 (1985).
622. M. Mori, N. Kanda, Y. Ban, *J. Chem. Soc., Chem. Commun.*, 1375 (1986).
623. B. M. Trost, S-F. Chen, *J. Am. Chem. Soc.*, **108**, 6053 (1986).
624. G. D. Sriyani Ananda, A. M. Z. Slawin, R. J. Stoodley, D. J. Williams, *J. Chem. Soc., Chem. Commun.*, 165 (1986).
625. B. Ledoussal, A. Gorgues, A. LeCaq, *J. Chem. Soc., Chem. Commun.*, 171 (1986).
626. V. F. Patel, G. Pattenden, J. J. Russell, *Tetrahedron Lett.*, **27**, 2303 (1986).
627. H. Buandal, G. Pattenden, J. J. Russell, *Tetrahedron Lett.*, **27**, 2299 (1986).
628. J. Mulzer, P. DeLasalle, Z. Freissler, *Liebigs Ann. Chem.*, 1152 (1986).
629. M. F. Semmelhack, J. Park, *Organometallics*, **5**, 2550 (1986).
630. H. Sheng, S. Lin, Y. Huang, *Tetrahedron Lett.*, **27**, 4893 (1986).
631. A. Arcadi, F. Marinelli, S. Cacchi, *Synthesis*, 749 (1986).
632. Y. Inoue, S. Ajioka, M. Toyofuku, A. Mori, T. Fukui, Y. Kawashima, S. Miyano, H. Hashimoto, *J. Mol. Catal.*, **32**, 91 (1985).
633. Y. Yamamoto, H. Suzuki, Y. Moro-oka, *Chem. Lett.*, 73 (1986).
634. A. J. Pearson, S. L. Kole, J. Yoon, *Organometallics*, **5**, 2075 (1986).
635. V. V. Litvak, L. I. Goryunov, V. D. Shteingarts, *Zh. Org. Khim.*, **22**, 157 (1986).
636. J. X. Wang, H. Alper, *J. Org. Chem.*, **51**, 273 (1986).
637. Y. Ishii, K. Osakada, T. Ikariya, M. Saburi, S. Yoshikawa, *J. Org. Chem.*, **51**, 2034 (1986).
638. Y. Ishii, K. Suzuki, T. Ikariya, M. Saburi, S. Yoshikawa, *J. Org. Chem.*, **51**, 2822 (1986).
639. N. Fujimoto, H. Nishino, K. Kurosawa, *Bull. Chem. Soc., Jpn.*, **59**, 3161 (1986).
640. T. Hosokawa, T. Kono, T. Uno, S-i. Murahashi, *Bull. Chem. Soc., Jpn.*, **59**, 2191 (1986).
641. H. Arzoumanian, J-F. Petrignani, *Tetrahedron Lett.*, **27**, 5979 (1986).
642. J.C.Sarma, R.P.Sharma, *Heterocycles*, **24**, 441 (1986).
643. S.E.Drewes, R.F.A.Hoole, *Synth. Commun.*, **15**, 1067 (1985).
644. N.Yanagihara, C.Lambert, K.Pritani, K.Utimoto, H. Nozaki, *J. Am. Chem. Soc.*, **108**, 2753 (1986).
645. K. Iritani, N. Yanagihara, K. Utimoto, *J. Org. Chem.*, **51**, 5499 (1986).
646. W.Tam, *J. Org. Chem.*, **51**, 2977 (1986).
647. W.P.Henry, R.P.Hughes, *J. Am. Chem. Soc.*, **108**, 7862 (1986).

648. S.G.Shim, K.T.Huh, W.H.Park, *Tetrahedron*, **42**, 259 (1986).
649. D.Lathbury, P.Vernon, T. Gallagher, *Tetrahedron Lett.*, **27**, 6009 (1986).
650. Y.Tamaru, M.Hojo, S-i.Kawamura, Z-i.Yoshida, *J. Org. Chem.*, **51**, 4089 (1986).
651. N.Chatani, T.Hanafusa, *Tetrahedron Lett.*, **27**, 4201 (1986).
652. O.Attanasi, M.Grossi, F.Serra-Zanetti, *Org. Prep. Proced. Int.*, **18**, 1 (1986).
653. E.Hernandez, H.Hoberg, *J. Organomet. Chem.*, **315**, 245 (1986).
654. F.Henin, J. Muzart, J-P.Pete, *Tetrahedron Lett.*, **27**, 6339 (1986).
655. S-H.Han, G.L.Geoffroy, A.L.Rheingold, *Organomet.*, **5**, 2561 (1986).
656. M.Mori, Y.Uozumi, M.Kimura, Y.Bun, *Tetrahedron*, **42**, 3793 (1986).
657. R.Grigg, V.Sridharan, T.Worakun, *J. Chem. Soc., Chem. Comm.*, 1697 (1986).
658. H.Boennemann, W.Brijoux, *Bull. Soc. Chim. Belg.*, **94**, 635 (1985).
659. Y.B.Taarit, Y.Diab, B.Elleuch, M.Kerkani, M.Chihaoui, *J. Chem. Soc.*, 402 (1986).
660. G.Vitulli, S.Bertozzi, R.Lazavvoni, P.Salvadovi, *J. Organomet. Chem.*, **307**, C35 (1986).
661. B.Potthoff, E.Breitmaier, *Synthesis*, 584 (1986).
662. L.S.Hegedus, P.R.Weider, T.A.Mulhern, H.Asada, S.D'Andrea, *Gazz. Chim. Ital.*, **116**, 213 (1986).
663. A.Kasahara, I.Izumi, S.Murakami, H.Yanai, M.Takatori, *Bull. Chem. Soc., Jpn.*, **59**, 927 (1986).
664. L.Canoira, J.G.Rodriguez, *J. Heterocycl. Chem.*, **22**, 1511 (1985).
665. J.Rodriguez, L.Canoira, *J. Heterocycl. Chem.*, **22**, 883 (1985).
666. T.Sakakibara, Y.Tanaka, S-i.Yamasaki, *Chem. Lett.*, 797 (1986).
667. T.Sakamoto, Y.Kondo, H.Yamanaka, *Heterocycles*, **24**, 31 (1986).
668. Y.Tsuji, K.T.Huh, Y.Watanabe, *Tetrahedron Lett.*, **27**, 377 (1986).
669. Y.Tsuji, K.T.Huh, Y.Yokoyama, Y.Watanabe, *J. Chem. Soc., Chem. Comm.*, 1575 (1986).
670. C.Crotti, S.Cerini, B.Rundone, S.Tollari, F.Demartin, *J. Chem. Soc., Chem. Comm.*, 785 (1986).
671. D.H.Lloyd, D.E.Nichols, *J. Org. Chem.*, **51**, 4294 (1986).
672. R.Aumann, H.Heinen, C.Krüger, Y-H.Tsay, *Chem. Ber.*, **119**, 3141 (1986).
673. R.Aumann, H.Heinen, *Chem. Ber.*, **119**, 2289 (1986).
674. W.D.Jones, W.P.Kosar, *J. Am. Chem. Soc.*, **108**, 5640 (1986).
675. L.S.Hegedus, T.A.Mulhern, H.Asada, *J. Am. Chem. Soc.*, **108**, 6224 (1986).
676. T.Klingstedt, A.Hallberg, P.Dunbar, A.Martin, *J. Heterocycl. Chem.*, **22**, 1547 (1985).
677. R.Aumann, E.Kuckert, *Chem. Ber.*, **119**, 156 (1986).
678. R.Connell, F.Scavo, P.Helquist, B.Akermark, *Tetrahedron Lett.*, **27**, 5559 (1986).
679. K.R.Mohan, N.V.S.Rao, *Acta Cienc. Indica, (Ser.) Chem.*, **10**, 185 (1984).
680. Y.Ito, M.Sawamura, T.Hayashi, *J. Am. Chem. Soc.*, **108**, 6405 (1986).
681. K.Takagi, *Chem. Lett.*, 265 (1986).

682. M.Mori, H.Kobayashi, M.Kimura, Y.Ban, *Heterocycles*, **23**, 2803 (1985).
683. K.L.Hoffmann, G.Maas, M.Regitz, *Chem. Ber.*, **118**, 3700 (1985).
684. M.Mizutani, Y.Sanemitsu, *Tetrahedron*, **42**, 305 (1986).
685. S.Jeropoulos, E.H.Smith, *J. Chem. Soc., Chem. Comm.*, 1621 (1986).
686. H.Kumobayashi, S.Mitsubishi, S.Akutagawa, S.Ohtsuka, *Chem. Lett.*, 157 (1986).
687. G.M.Arvanitis, J.Schwartz, D.VanEngen, *Organomet.*, **5**, 2157 (1986).
688. S.K.Tyrlik, A.Korda, A.Gieysztor, *J. Mol. Catal.*, **34**, 313 (1986).
689. T.Okano, Y.Moriyama, H.Konishi, J.Kiji, *Chem. Lett.*, 1463 (1986).
690. N.Ono, I.Hamamoto, A.Kamimura, A.Kaji, *J. Org. Chem.*, **51**, 3736 (1986).
691. J.Tsuji, I.Minami, I.Shimizu, *Synthesis*, 623 (1986).
692. T.Taniguchi, J.Inanaga, M.Yamaguchi, *Tetrahedron Lett.*, **27**, 601 (1986).
693. M.Mohri, H.Kinoshita, K.Inomata, H.Kotake, H.Tabagaki, K.Yamazaki, *Chem. Lett.*, 1177 (1986).
694. S.Araki, M.Hatano, Y.Butsugan, *J. Org. Chem.*, **51**, 2126 (1986).
695. V.Galamb, S.C.Shim, F.Sibtain, H.Alper, *Israel J. Chem.*, **26**, 216 (1986).
696. M.D.Fryzuk, G.S.Bates, C.Stone, *Tetrahedron Lett.*, **27**, 1537 (1986).
697. S.Calet, H.Alper, *Tetrahedron Lett.*, **27**, 3573 (1986).
698. F.Guike, O.Dangles, G.Balavoine, *Tetrahedron Lett.*, **27**, 2365 (1986).
699. T.Antousson, A.Heumann, C.Moberg, *J. Chem. Soc., Chem. Comm.*, 518 (1986).
700. Q-Y.Chen, Y-B.He, Z-Y.Yang, *J. Chem. Soc., Chem. Comm.*, 1452 (1986).
701. S.Cacchi, P.G.Ciathini, E.Morena, G.Ortar, *Tetrahedron Lett.*, **27**, 5541 (1986).
702. I.PriBar, O.Buchman, *J. Org. Chem.*, **51**, 734 (1986).
703. Y.Akita, A.Inoue, K.Ishida, K.Terui, A.Ohta, *Syn. Comm.*, **16**, 1067 (1986).
704. T.Okano, M.Iwahara, T.Suzuki, H.Konishi, J.Kiji, *Chem. Lett.*, 1467 (1986).
705. J.Yamashita, Y.Inoue, T.Kondo, H.Hashimoto, *Bull. Chem. Soc., Jpn.*, **58**, 2709 (1985).
706. J.Lu, Y.Qian, *Wuji Huaxue*, **1**, 130 (1985).
707. H.A.Zahalka, H.Alper, *Organometallics*, **5**, 1908 (1986).
708. L.H.P.Gommans, L.Main, B.K.Nicholson, *J. Chem. Soc., Chem. Comm.*, 12 (1986).
709. T.G.Alkhozov, K.Yu.Adzhamov, A.K.Khanmamedova, *Probl. Kinet. Katal.*, **19**, 83 (1985).
710. I.S.Shaw, *Diss. Abstr. Int. B.*, **46**, 2742 (1986).
711. K.Takehira, T.Hayakawa, H.Orita, *Chem. Lett.*, 1835 (1985).
712. B.L.Feringa, *J. Chem. Soc., Chem. Comm.*, 909 (1986).
713. A.K.Bose, L.Krishnan, D.R.Wagle, M.S.Manhas, *Tetrahedron Lett.*, **27**, 5955 (1986).
714. D.Dimitrov, V.Sirakova, R.Stefanova, *Oxid. Commun.*, **7**, 399 (1984).

715. T.Antonsson, S.Hansson, C.Moberg, *Acta Chem. Scand., Ser. B.*, **B39**, 593 (1985).
716. R.S.Drago, B.B.Corden, C.W.Barnes, *J. Am. Chem. Soc.*, **108**, 2453 (1986).
717. P.Battioni, J-P.Renaud, J.F.Bartoli, D.Mansuy, *J. Chem. Soc., Chem. Comm.*, 341 (1986).
718. K.Yamawaki, T.Yoshida, T.Suda, Y.Ishii, M.Ogawa, *Synthesis*, 59 (1986).
719. H.Firouzabadi, N.Iranpoor, F.Kialezadek, J.Toofan, *Tetrahedron*, **42**, 719 (1986).
720. S.Torii, T.Inokuchi, T.Sugura, *J. Org. Chem.*, **51**, 155 (1986).
721. F.P.Ballistreri, S.Failla, G.A.Tomaselli, R.Curci, *Tetrahedron Lett.*, **27**, 5139 (1986).
722. P.C.B.Page, S.Rosenthal, *Tetrahedron Lett.*, **27**, 1947 (1986).
723. J.Muzart, *Tetrahedron Lett.*, **27**, 3139 (1986).
724. M.Nitta, Y.Iino, *Bull. Chem. Soc., Jpn.*, **59**, 2365 (1986).
725. N.Narasimahamurthy, A.G.Samuels, *Tetrahedron Lett.*, **27**, 3911 (1986).
726. M.Muyase, E.Kotani, S.Tobinaga, *Chem. Pharm. Bull.*, **34**, 3595 (1986).
727. R.W.Wegman, D.C.Busby, *J. Chem. Soc., Chem. Comm.*, 332 (1986).
728. T.Kanetani, K.Kawamura, M.Tsubuki, T.Honda, *Chem. Pharm. Bull.*, **33**, 4821 (1985).
729. A.P.Masters, T.S.Sorensen, T.Ziegler, *J. Org. Chem.*, **51**, 3558 (1986).
730. I.Minami, K.Takahashi, I.Shimizu, T.Kimura, J.Tsuji, *Tetrahedron*, **42**, 2971 (1986).
731. C-S.Chien, T.Kawasaki, M.Sakamoto, *Chem. Pharm. Bull.*, **33**, 5071 (1985).
732. I.Ojima, K.Hirai, *Asymmetric Synth.*, **5**, 102 (1985).
733. Y.Seki, K.Taheshita, K.Kawamoto, S.Murai, N.Sonoda, *J. Org. Chem.*, **51**, 3890 (1986).
734. T.Hayashi, M.Konishi, Y.Okamoto, K.Kabeta, M.Kumada, *J. Org. Chem.*, **51**, 3772 (1986).
735. B.L.Chenard, C.M.VanZyl, *J. Org. Chem.*, **51**, 3561 (1986).
736. K.Wakamatsu, T.Nonaeka, Y.Okuda, W.Tuckmantel, K.Oshima, K.Utimoto, H.Nozaqi, *Tetrahedron*, **42**, 4427 (1986).
737. K.Nozaqi, T.Nonaku, W.Tuckmantel, K.Oshima, K.Utimoto, *Tetrahedron Lett.*, **27**, 2007 (1986).
738. K.Fugami, K.Oshima, K.Utimoto, H.Nozaqi, *Tetrahedron Lett.*, **27**, 2161 (1986).
739. I.Fleming, F.J.Pulido, *J. Chem. Soc., Chem. Comm.*, 1010 (1986).
740. M.Stobbe, O.Reiser, T.Thiemann, R.G.Daniels, A.deMeizese, *Tetrahedron Lett.*, **27**, 2353 (1986).
741. Y.Ito, T.Banko, T.Matsuura, M.Ishikawa, *J. Chem. Soc., Chem. Comm.*, 980 (1986).
742. C-H.Lin, C-Y.Lee, C-S.Lin, *J. Am. Chem. Soc.*, **108**, 1323 (1986).
743. B.M.Trost, T.S.Scanlem, *Tetrahedron Lett.*, **27**, 4141 (1986).



744. M.Kosugi, T.Ogata, M.Terada, H.Sano, T.Migita, *Bull. Chem. Soc., Jpn.*, **58**, 3657 (1985).
745. M.Kameyama, N.Kamigata, M.Kobayashi, *Chem. Lett.*, 527 (1986).
746. Y.Inoue, H.Hashimoto, *Bull. Chem. Soc., Jpn.*, **59**, 3705 (1986).
747. N.Ono, I.Hamamoto, T.Kawai, A.Kaji, R.Tamura, M.Kakihana, *Bull. Chem. Soc., Jpn.*, **59**, 405 (1986).
748. S.Ahmad, J.Iqbal, *Tetrahedron Lett.*, **27**, 3791 (1986).
749. H.B.Kagan, E.Dunach, C.Nemecek, P.Pitchen, O.Samuel, H.Shu, *Pure Appl. Chem.*, **57**, 1911 (1985).
750. H.J.Cristan, B.Chabaud, R.Labaudiniere, H.Christol, *J. Org. Chem.*, **51**, 875 (1986).
751. Y.Xu, J.Xia, H.Guo, *Synthesis*, 691 (1986).
752. Y.Xu, Z.Li, *Synthesis*, 240 (1986).
753. Y.Xu, J.Zhang, *J. Chem. Soc., Chem. Comm.*, 1606 (1986).
754. X.Lu, J.Zhu, *Synthesis*, 563 (1986).
755. R.S.Varma, M.Varma, G.W.Kabalka, *Synth. Comm.*, **16**, 91 (1986).
756. H.Marrakchi, J.B.Nguini Effa, M.Haimeur, J.Lieto, J.P.Aune, *Bull. Soc. Chim. Fr.*, 390 (1985).
757. R.L.Halterman, K.P.C.Vollhardt, *Tetrahedron Lett.*, **27**, 1461 (1986).
758. A.H.Herring, S.J.Higgins, G.B.Jacobsen, B.L.Shaw, *J. Chem. Soc., Chem. Com.*, 882 (1986).
759. M.E.Fakley, *Organomet. Chem.*, **14**, 373 (1986).
760. A.Yamamoto, *J. Organomet. Chem.*, **300**, 347 (1986).
761. L.V.Lyashenko, *Katal. Katal.*, **23**, 3 (1985).
762. R.A.Sawicki, *Prepr. Am. Chem. Soc., Div. Pet. Chem.*, **30**, 415 (1985).
763. D.A.Lemenovskii, V.P.Fedin, *Usp. Khim.*, **55**, 303 (1986).
764. E.C.Constable, *Coord. Chem. Rev.*, **73**, 59 (1986).
765. J.E.Turp, N.Turp, *Coord. Chem. Rev.*, **73**, 1 (1986).
766. N.Turp, *Coord. Chem. Rev.*, **72**, 197 (1986).
767. K.R.Seddon, *Coord. Chem. Rev.*, **71**, 1 (1986).
768. P.C.Srivastava, M.M.Goodman, F.F. Kanpp, Jr., *Synth. Appl. Isot. Labeled Compd. Proc. Int. Symp., 2nd*, 213 (1986).
769. K.Schloegl, O.Hofer, *Pure Appl. Chem.*, **58** (1986).
770. R.Sheldon, *Bull. Soc. Chim. Belg.*, **94**, 651 (1985).
771. P.J.Brothers, J.P.Collman, *Accts. Chem. Res.*, **7**, 209 (1986).
772. G.W.Parshall, W.A.Nugent, D.M.T.Chan, W.Tam, *Pure Appl. Chem.*, **57**, 1809 (1985).
773. Y.Ito, *Kagaku Kogyo (Tokyo)*, **37**, 452 (1984).
774. H.Nozaki, *Kagaku (Kyoto)*, **40**, 354 (1985).
775. R.Uson, *Actual. Chim. Ther.*, **11**, 197 (1984).

776. L.S.Hegedus, *J. Organomet. Chem.*, **298**, 207 (1986).
777. G.H.Posner, *Chem. Rev.*, **86**, 831 (1986).
778. F.R.Hartley, *The Chemistry of Metal-Carbon Bond, Vol. 2*, (1985).
779. F.R.Hartley, S.Patai, *The Chemistry of the Metal-Carbon Bond, Vol 3*, (1985).
780. J.J.Ziolkowski, *Wiad. Chem.*, **39**, 515 (1985).
781. S.G.Davies, S.E.Thomas, P.F.Gordon, *Gen. Synth. Methods*, **8**, 312 (1986).
782. A.E.Martell, *Chem. Changes Food Process.*, 33 (1985).
783. S.Murahashi, *Seisan to Gijutsu*, **36**, 30 (1984).
784. V.Sriyonyongwat, *Diss. Abstr. Int. B.*, **46**, 3027 (1986).
785. G.Wilke, *Org. Synth.: Interdiscip. Challenge, Proc. IUPAC Symp.*, 5th, 1 (1985).
786. H.Nozaki, *Yakugaku Zasshi*, **105**, 1101 (1985).
787. G.P.Chiusoli, *J. Organomet. Chem.*, **300**, 57 (1986).
788. Z.Paal, *Kem. Ujabb Eredmenyei*, **64**, 7 (1986).
789. R.H.Crabtree, M.J.Burk, R.P.Dion, E.M.Holt, M.E.Lavin, S.M.Morehouse, C.P.Parnell, R.J.Uriarte, *Chem. Ind. (Dekker)*, **22**, 37 (1985).
790. G.Li, L.Zhang, *Huaxue Tongbao*, 1 (1985).
791. W.A.G.Graham, *J. Organomet. Chem.*, **300**, 81 (1986).
792. J.Halpern, *Inorg. Chim. Acta*, **100**, 41 (1985).
793. D.O'Hare, *Pure Appl. Chem.*, **57**, 1897 (1985).
794. U.M.Dzhemilev, O.S.Vostrikova, A.G.Ibragimov, *Usp. Khim.*, **55**, 191 (1986).
795. C.E.Holloway, M.Melnik, *J. Organomet. Chem.*, **303**, 1 (1986).
796. M.A.Jamieson, N.Serpono, E.Pelizzetti, *Coord. Chem. Rev.*, **73**, 175 (1986).
797. M.T.Reetz, *Pure Appl. Chem.*, **57**, 1781 (1985).
798. U.M.Dzhemilev, O.S.Vostrikova, G.A.Tolstikov, *J. Organomet. Chem.*, **304**, 17 (1986).
799. M.G.Saha, *Diss. Abstr. Int. B.*, **46**, 2671 (1986).
800. Y.K.Jeong, *Hwahak Kwa Kongop Ut Chinbo*, **25**, 477 (1985).
801. B. Ganem, J.O.Osby, *Chem. Rev.*, **86**, 763 (1986).
802. J.J.Weers, *Diss. Abstr. Int. B.*, **46**, 518 (1985).
803. A.Suzuki, *Pure Appl. Chem.*, **58**, 629 (1986).
804. L.Miginiac, *Chem. Met.-Carbon Bond*, **3**, 99 (1985).
805. T.N.Mitchell, *J. Organomet. Chem.*, **304**, 1 (1986).
806. J.K.Stille, *Angew. Chem.*, **98**, 504 (1986).
807. M.Rosenblum, *J. Orgnaomet. Chem.*, **300**, 191 (1986).
808. R.Noyori, Y.Hayakawa, *Tetrahedron*, **41**, 5879 (1985).
809. M.Rosenblum, *J. Orgnaomet. Chem.*, **300**, 191 (1986).
810. A.A.Koridze, *Usp. Khim.*, **55**, 277 (1986).
811. J. Mann, *Tetrahedron*, **42**, 4611 (1986).
812. Gmelin Handbook of Inorganic Chemistry Organoiron Compounds, Part A8, Berlin, Fed. Rep. Ger., 419 (1986).

813. M.E.Welker, *Diss. Abstr. Int. B.*, **46**, 2674 (1986).
814. M.D.Seidler, *Diss. Abstr. Int. B.*, **46**, 1162 (1985).
815. M.A.Bennett, *J. Organomet. Chem.*, **300**, 7 (1986).
816. G.R.Newkome, W.E.Pirckett, V.K.Gupter, G.E.Kiefer, *Chem. Rev.*, **86**, 451 (1986).
817. R.A.Ekeland, *Diss. Abstr. Int. B.*, **46**, 1171 (1985).
818. M.Green, *J. Organomet. Chem.*, **300**, 93 (1986).
819. R.R.Schrock, *Acc. Chem. Res.*, **19**, 342 (1986).
820. J.P.Collman, L.S.Hegedus, *Nachr. Chem., Tech. Lab.*, **34**, 22 (1986).
821. Y.Yamamoto, *Angew. Chem. Int. Ed.*, **25**, 947 (1986).
822. G.W.Ebert, *Diss. Abstr. Int. B.*, **46**, 3445 (1986).
823. B.M.Trost, *J. Organomet. Chem.*, **300**, 263 (1986).
824. W.R.Roper, *J. Organomet. Chem.*, **300**, 167 (1986).
825. R.F.Heck, *Palladium Reagents in Organic Syntheses*, Academic Press, (1986).
826. O.V.Gritsenko, A.A.Bagtur'yants, I.I.Moiseev, V.B.Kazanskii, *Russ. Chem. Rev.*, **54**, 1151 (1985).
827. P.A.Chaloner, *Coordi. Chem. Rev.*, **72**, 1 (1986).
828. A.Yamamoto, T.Yamamoto, F.Ozawa, *Pure Appl. Chem.*, **57**, 1799 (1985).
829. B.D.Rihter, *Diss. Abstr. Int. B.*, **46**, 3453 (1986).
830. J.Tsuji, *J. Organomet. Chem.*, **300**, 281 (1986).
831. B.M.Trost, *J. Organomet. Chem.*, **300**, 263 (1986).
832. A.D.Cameron, *Diss. Abstr. Int. B.*, **46**, 4233 (1986).
833. Y.Qian, M.Xu, *Huaxue Shiji*, **8**, 147 (1986).
834. N.Z.Huang, *Diss. Abstr. Int. B.*, **46**, 522 (1985).
835. D.Steinborn, R.Tauke, *Z. Chem.*, **26**, 349 (1986).
836. Y.Yamamoto, *Kagaku (Kyoto)*, **40**, 364 (1985).
837. K.Schloegl, *J. Organomet. Chem.*, **300**, 219 (1986).
838. W.M.H.Sachtler, *Chem. Ind. (Dekker)*, **22**, 189 (1985).
839. H.Brunner, *J. Organomet. Chem.*, **300**, 39 (1986).
840. J.E.Backvall, *Org. Synth.: Interdiscip. Challenge, Proc. IUPAC Symp.*, **5th**, 69 (1985).
841. K.Narasaka, *Pure Appl. Chem.*, **57**, 1883 (1985).
842. I.Ojima, *Yuki Gosei Kagaku Kyokaishi*, **44**, 499 (1986).
843. H.Brunner, A.Knott, *Z. Naturforsch., B: Anorg. Chem., Org. Chem.*, **40B**, 1243 (1985).