

# Reactions of $\text{TiCl}_4$ with phosphines and alkylating reagents: an organometallic route to a titanium(II) cluster compound<sup>1</sup>

F. Albert Cotton<sup>a,\*</sup>, Carlos A. Murillo<sup>a,b</sup>, Marina A. Petrukhina<sup>a</sup>

<sup>a</sup> *Laboratory for Molecular Structure and Bonding, Department of Chemistry, Texas A&M University, and P.O. Box 300012, College Station, TX 77842-3012, USA*

<sup>b</sup> *Department of Chemistry, Universidad de Costa Rica, Ciudad Universitaria, City??, Costa Rica*

Received 12 March 1998

## Abstract

Treatment of  $\text{TiCl}_4$  with a stoichiometric amount of 1,2-bis(dimethylphosphino)ethane (dmpe) gives  $\text{TiCl}_4(\text{dmpe})$  (**1**). This compound can be readily alkylated by 1 or 2 equivalents of  $\text{PhCH}_2\text{MgCl}$  affording  $\text{TiCl}_3(\text{PhCH}_2)(\text{dmpe})$  (**2**) and  $\text{TiCl}_2(\text{PhCH}_2)_2(\text{dmpe})$  (**3**), respectively. Syntheses and crystal structures of the three mononuclear titanium(IV) compounds **1–3** are presented. Decomposition of ' $\text{TiCl}_3(\text{Bu}')(\text{dmpe})$ ' produces the dinuclear titanium(III) edge-sharing complex,  $\text{Ti}_2\text{Cl}_4(\mu\text{-Cl})_2(\text{dmpe})_2$  (**4a**). Its analogue,  $\text{Ti}_2\text{Cl}_4(\mu\text{-Cl})_2(\text{depe})_2$  (**4b**) has been obtained by direct reaction of  $\text{TiCl}_3(\text{THF})_3$  with the corresponding phosphine. Thermal decomposition of ' $\text{TiCl}_2(\text{Bu}')_2(\text{dmpe})$ ' provides the first true, molecular metal atom cluster of titanium(II),  $\text{Ti}_3\text{Cl}_6(\text{dmpe})_3$  (**5**). The cluster molecule consists of an equilateral triangle of  $\text{Ti}^{\text{II}}$  atoms with three coplanar  $\mu\text{-Cl}$  atoms bridging the edges. Each titanium atom is further coordinated by a chelating dmpe molecule and a chloride ion, with Ti–Ti distances of 2.872(3) Å. The compound appears to be slightly paramagnetic but this is probably the result of a small amount of decomposition due to the difficulty of handling this pyrophoric complex. It is proposed that there are genuine Ti–Ti single bonds, and that this is a true metal atom cluster compound. © 1999 Published by Elsevier Science S.A. All rights reserved.

**Keywords:** Titanium complexes; Crystal structures; Ti–Ti bonding; Cluster; Bond distortions

## 1. Introduction

Titanium tetrachloride readily forms adducts of the type  $\text{TiCl}_4\text{L}_n$  with donor ligands [1]. The coordination numbers are generally five or six but higher coordination numbers also occur [2]. It is also known to react with alkylating reagents to produce substitution compounds of the type  $\text{TiCl}_{4-n}\text{R}_n$  [3].

In the presence of phosphines, reduction of  $\text{TiCl}_4$  to produce  $\text{Ti}^{\text{III}}$  species is sometimes observed [4], but further reduction to  $\text{Ti}^{\text{II}}$  is difficult to accomplish. Indeed, the chemistry of divalent titanium is exiguous

though not entirely lacking. There is no significant aqueous chemistry because  $\text{Ti}^{\text{II}}$  is too strong a reducing agent. The complexes that have been reported are all mononuclear, examples being  $\text{TiCl}_2(\text{py})_4$  [5] and  $\text{TiX}_2(\text{dmpe})_2$  ( $\text{X} = \text{Cl}, \text{CH}_3, \text{BH}_4$ ;  $\text{dmpe} = \text{Me}_2\text{PC}_2\text{H}_4\text{PMe}_2$ ) [6,7].

A study of the reactions of phosphine adducts of  $\text{Ti}^{\text{IV}}$  with Grignard reagents has now yielded a series of complexes with titanium in oxidation states varying from II to IV.

## 2. Experimental section

### 2.1. General procedures

Manipulations during the preparation of all com-

\* Corresponding author. Tel.: +1 409 8459351; fax: +1 409 8459351; e-mail: cotton@tamu.edu

<sup>1</sup> Dedicated to Professor Brian Johnson on the occasion of his 60th birthday.

pounds were carried out under an atmosphere of argon using standard Schlenk techniques. Chemicals were purchased from the following commercial sources and used as received:  $\text{TiCl}_4$ ,  $\text{PhCH}_2\text{MgCl}$ ,  $\text{Bu}^i\text{MgCl}$  (Aldrich),  $\text{dmpe}$  ( $\text{Me}_2\text{PC}_2\text{H}_4\text{PMe}_2$ ) and  $\text{depe}$  ( $\text{Et}_2\text{PC}_2\text{H}_4\text{PEt}_2$ ) (Strem Chemicals),  $\text{C}_6\text{D}_6$  (Cambridge Isotope Laboratories). All solvents used were freshly distilled under  $\text{N}_2$  from suitable drying agents. NMR spectra were recorded at room temperature on a UNITY-plus 300 multinuclear spectrometer operated at 300 MHz for  $^1\text{H}$ , and at 121.4 MHz for  $^{31}\text{P}$  (using 85%  $\text{H}_3\text{PO}_4$  as an external standard). Elemental analyses were done on all thermally stable compounds by Canadian Microanalytical Services; they were satisfactory.

## 2.2. Syntheses of compounds 1–5

### 2.2.1. $\text{TiCl}_4(\text{dmpe})$ (**1**)

A solution of 1 ml of  $\text{TiCl}_4$  (9 mmol) in 20 ml of hexanes was cooled to  $-20^\circ\text{C}$ ; then a stoichiometric amount of  $\text{dmpe}$  (1.5 ml, 9 mmol) was added. An orange solid began to precipitate upon mixing. The mixture was warmed to room temperature, and stirring was continued over 1 h. The precipitate was isolated by filtration, washed thoroughly with hexanes ( $3 \times 15$  ml) and dried under vacuum. Yield: 2.88 g (94.1%).

Crystals suitable for X-ray crystallography were obtained by slow crystallization from toluene at  $-20^\circ\text{C}$ .  $^{31}\text{P}\{^1\text{H}\}$  NMR ( $\text{C}_6\text{D}_6$ ,  $20^\circ\text{C}$ ):  $\delta = 26.08$  (s).  $^1\text{H}$  NMR (300 MHz,  $\text{C}_6\text{D}_6$ ):  $\delta = 0.95$ – $0.99$  (d, 4H,  $\text{CH}_2$ ), 1.10–1.14 (d, 12H,  $\text{CH}_3$ ).

### 2.2.2. $\text{TiCl}_3(\text{PhCH}_2)(\text{dmpe})$ (**2**)

To a cooled suspension ( $-20^\circ\text{C}$ ) containing 0.67 g (1.96 mmol) of **1** in 20 ml of toluene were added 2.0 ml of a 1 M solution of  $\text{PhCH}_2\text{MgCl}$  in diethyl ether. A red-purple color developed in a few minutes. The suspension was stirred for 1.5 h at  $0^\circ\text{C}$  and then filtered. The red-brown filtrate was placed in the freezer. Dark-brown crystals of **2** formed in a few days. Yield: 0.25 g (32.7%).  $^{31}\text{P}\{^1\text{H}\}$  NMR ( $\text{C}_6\text{D}_6$ ,  $20^\circ\text{C}$ ):  $\delta = 29.6$  (d),  $\delta = 28.4$  (d).  $^1\text{H}$  NMR (300 MHz,  $\text{C}_6\text{D}_6$ ):  $\delta = 7.45$  (d, 2H,  $\text{PhH}$ -meta), 7.27 (t, 2H,  $\text{PhH}$ -ortho), 7.14 (m, H,  $\text{PhH}$ -para), 3.40 (d, 2H,  $\text{CH}_2$ -Ph), 1.43 (d, 4H,  $\text{CH}_2$ ), 1.20 (d, 12H,  $\text{CH}_3$ ).

### 2.2.3. $\text{TiCl}_2(\text{PhCH}_2)_2(\text{dmpe})$ (**3**)

**2.2.3.1. Method 1.** A suspension of 0.51 g (1.5 mmol) of **1** in 25 ml of toluene was cooled to  $-20^\circ\text{C}$ ; then 3.2 ml of a 1 M solution of  $\text{PhCH}_2\text{MgCl}$  in diethyl ether were added. The color turned dark-brown immediately. The mixture was stirred for 2 h at ca.  $0^\circ\text{C}$ , and the volume of the solution was then reduced by half. The mixture

was filtered, and the filtrate was kept in the freezer. Dark-brown crystals of **3** grew in a week. Yield: 0.33 g (48.9%).

**2.2.3.2. Method 2.** To 10 ml of a 1 M solution of  $\text{PhCH}_2\text{MgCl}$  in diethyl ether, 0.5 ml of  $\text{TiCl}_4$  (4.5 mmol) was added at  $-40^\circ\text{C}$ . The mixture was stirred for 1 h, warmed to  $0^\circ\text{C}$  and then filtered. A stoichiometric amount of  $\text{dmpe}$  (4.5 mmol) in hexanes (7 ml) was added to the filtrate resulting in a dark-brown precipitate. It was filtered off, dried under vacuum, and then it was dissolved in 8 ml of toluene. The solution was kept in the freezer. Crystals of **3** grew after few days. Yield: 0.76 g (37.6%).  $^{31}\text{P}\{^1\text{H}\}$  NMR ( $\text{C}_6\text{D}_6$ ,  $20^\circ\text{C}$ ):  $\delta = 18.6$  (s).  $^1\text{H}$  NMR (300 MHz,  $\text{C}_6\text{D}_6$ ):  $\delta = 7.40$  (d, 2H,  $\text{PhH}$ -meta), 7.15 (m, 2H,  $\text{PhH}$ -ortho), 7.00 (t, H,  $\text{PhH}$ -para), 2.85 (t, 4H,  $\text{CH}_2$ -Ph), 1.27 (d, 4H,  $\text{CH}_2$ ), 0.90 (d, 12H,  $\text{CH}_3$ ).

### 2.2.4. $[\text{TiCl}_2(\mu\text{-Cl})(\text{dmpe})]_2$ (**4a**)

**2.2.4.1. Method 1.** A suspension containing 0.34 g (1.0 mmol) of **1** in 20 ml of toluene was cooled to  $-20^\circ\text{C}$ . Then, 0.6 ml of a 2 M solution (1.2 mmol) of  $\text{Bu}^i\text{MgCl}$  in diethyl ether was added. The color of the mixture turned red-brown immediately. The mixture was warmed to room temperature and stirring was continued 2–3 h. The suspension was then filtered and the red filtrate was carefully layered with 20 ml of hexanes. Red crystals of **4a** formed in a few hours. Yield: 0.19 g (61.3%).

**2.2.4.2. Method 2.** To a suspension of 0.38 g (1 mmol) of  $\text{TiCl}_3(\text{THF})_3$  in 25 ml of toluene was added 0.3 ml of  $\text{dmpe}$ . After 20 min of stirring at room temperature a red solid started to precipitate. It was filtered off, washed with hexanes, and dried in vacuum. Yield: 0.25 g (79.4%). A few crystals of **4a** were obtained by slow diffusion of hexanes into the toluene filtrate.

### 2.2.5. $[\text{TiCl}_2(\mu\text{-Cl})(\text{depe})]_2$ (**4b**)

To a suspension containing 0.39 g (1.0 mmol) of  $\text{TiCl}_3(\text{THF})_3$  in 15 ml of toluene, 0.25 ml (ca. 1.1 mmol) of  $\text{depe}$  was added. The color of the mixture immediately turned brown-green. The mixture was stirred for 1 h at room temperature, and then filtered. The brown filtrate was carefully layered with 15 ml of hexanes. Red crystals of **4b** grew within a few hours. Yield: 0.26 g (68.1%).

### 2.2.6. $[\text{Ti}(\mu\text{-Cl})\text{Cl}(\text{dmpe})]_3 \cdot \text{C}_7\text{H}_8$ (**5** · $\text{C}_7\text{H}_8$ )

A suspension containing 0.51 g (1.5 mmol) of **1** in 20 ml of toluene was cooled to  $-20^\circ\text{C}$ , then  $\text{Bu}^i\text{MgCl}$  in diethyl ether (1.6 ml of a 2 M solution, 3.2 mmol) was added. The color of the mixture turned red-brown

Table 1  
Crystallographic data for **1–5**

	<b>1</b>	<b>2</b>	<b>3</b>	<b>4a</b>	<b>4b</b>	<b>5</b>
Empirical formula	TiCl <sub>4</sub> P <sub>2</sub> C <sub>6</sub> H <sub>16</sub>	TiCl <sub>3</sub> P <sub>2</sub> C <sub>13</sub> H <sub>23</sub>	TiCl <sub>2</sub> P <sub>2</sub> C <sub>20</sub> H <sub>30</sub>	Ti <sub>2</sub> Cl <sub>6</sub> P <sub>4</sub> C <sub>12</sub> H <sub>32</sub>	Ti <sub>2</sub> Cl <sub>6</sub> P <sub>4</sub> C <sub>20</sub> H <sub>48</sub>	Ti <sub>3</sub> Cl <sub>6</sub> P <sub>6</sub> C <sub>25</sub> H <sub>56</sub>
Formula weight (g mol <sup>-1</sup> )	339.83	395.50	451.18	608.76	720.96	898.92
Crystal dimensions	0.20 × 0.15 × 0.10	0.50 × 0.30 × 0.20	0.60 × 0.35 × 0.30	0.25 × 0.12 × 0.10	0.30 × 0.20 × 0.10	0.12 × 0.10 × 0.10
Temperature (°C)	–60	–60	–60	–60	–60	–60
Crystal system	Orthorhombic	Orthorhombic	Tetragonal	Monoclinic	Orthorhombic	Trigonal
Space group	<i>Pbca</i>	<i>Pbca</i>	<i>I4/a</i>	<i>P2<sub>1</sub>/n</i>	<i>Pca2<sub>1</sub></i>	<i>R3c</i>
<i>a</i> (Å)	16.234(2)	13.859(1)	19.202(4)	9.261(3)	15.0307(8)	16.274(2)
<i>b</i> (Å)	14.335(2)	11.811(1)	13.277(6)	16.610(2)		
<i>c</i> (Å)	24.504(2)	22.792(3)	24.337(2)	10.879(3)	13.5556(6)	27.731(7)
$\beta$ (°)	90	90	90	95.43(2)	90	90
<i>V</i>	5702(1)	3730.8(6)	8973(3)	1331.7(8)	3384.3(5)	6360(1)
<i>Z</i>	16	8	16	2	4	6
<i>D</i> <sub>calc.</sub> (g cm <sup>-3</sup> )	1.583	1.408	1.336	1.518	1.415	1.408
Absorption coefficient (mm <sup>-1</sup> )	1.535	1.046	0.764	1.440	1.145	1.173
Radiation ( $\lambda$ ) (Å)	Mo–K $\alpha$ (0.71073)	Mo–K $\alpha$ (0.71073)	Mo–K $\alpha$ (0.71073)	Mo–K $\alpha$ (0.71073)	Mo–K $\alpha$ (0.71073)	Mo–K $\alpha$ (0.71073)
Data/observed/parameters	3742/3085/224	2453/2205/215	2932/2685/346	1739/1537/98	4409/4220/280	1854/1680/120
<i>R</i> <sub>1</sub> <sup>a</sup> ( <i>wR</i> <sub>2</sub> <sup>b</sup> ) [ <i>I</i> > 2 $\sigma$ ( <i>I</i> )]	0.0514/0.1125	0.0431/0.1016	0.0285/0.0665	0.0535/0.1301	0.0304/0.0711	0.0618/0.1213
<i>R</i> <sub>1</sub> <sup>a</sup> ( <i>wR</i> <sub>2</sub> <sup>b</sup> ) (all data)	0.0671/0.1249	0.0489/0.1108	0.0323/0.0714	0.0625/0.1389	0.0322/0.0739	0.0764/0.1395
Goodness-of-fit	1.14	1.04	1.09	1.10	1.10	1.10

$$^a R_1 = \sum ||F_o| - |F_c|| / \sum |F_o|$$

$$^b wR_2 = [\sum [w(F_o^2 - F_c^2)^2] / \sum [w(F_o^2)^2]]^{1/2}$$

immediately. The mixture was warmed to room temperature and the stirring was continued for 3 h. The volume of the solvent was reduced by more than half and the mixture was filtered. Tiny block-shaped crystals of [Ti( $\mu$ -Cl)Cl(dmpe)]<sub>3</sub>·C<sub>7</sub>H<sub>8</sub> (**5**·C<sub>7</sub>H<sub>8</sub>) formed after the dark-brown filtrate was kept in the refrigerator for about a week. Yield: 0.07 g (15.4%).

### 2.3. X-ray crystallographic procedures

Single crystals of **1–5** were obtained as described above. In each case, a crystal of suitable quality was affixed to the end of a quartz fiber with grease, and then placed in a cold nitrogen stream (–60°C) on a Nonius Fast diffractometer equipped with an area detector and monochromated Mo–K $\alpha$  radiation ( $\lambda$  = 0.71073 Å). Unit cell determinations and data collections followed routine procedures and practices of this laboratory [8]. Oscillation photographs of principal axes were taken to confirm Laue class and axial lengths. All data were corrected for Lorentz and polarization effects. The intensities for **1** and **5** were corrected for absorption anisotropy effects using a local adaptation of the program SORTAV [9].

All calculations were done on a DEC Alpha running VMS. The coordinates of titanium atoms for all of the structures were found in direct methods E-maps using the structure solution program SHELXTL [10]. The positions of the remaining atoms were located by the use of a combination of least squares refinements and

difference Fourier maps in the SHELXL-93 program [11]. Except for **3**, all hydrogen atoms were included at idealized positions for the structure factor calculations but not refined. Details of data collection and structure refinement for **1–5** are reported in Table 1.

## 3. Results and discussion

### 3.1. Description of structures

#### 3.1.1. TiCl<sub>4</sub>(dmpe) (**1**)

This compound crystallizes in the orthorhombic space group *Pbca* with sixteen molecules per unit cell. The structure of **1** consists of two crystallographically independent TiCl<sub>4</sub>(dmpe) molecules. A perspective view of one of them is presented in Fig. 1; the structural data are listed in Table 2. Each molecule consists of four chlorine and two phosphorus atoms bound to the Ti<sup>IV</sup> center with average Ti–Cl distances of 2.289(2) Å and Ti–P distances of 2.581(2) Å. The chelating dmpe ligand is crystallographically disordered only in one type of molecule. The polyhedron around the titanium atom is a distorted octahedron with bond angles ranging from 75.95(6) to 113.43(7)°.

#### 3.1.2. TiCl<sub>3</sub>(PhCH<sub>2</sub>)dmpe (**2**) and TiCl<sub>2</sub>(PhCH<sub>2</sub>)<sub>2</sub>dmpe (**3**)

Crystals of **2** conform to the orthorhombic space group *Pbca* with eight molecules per unit cell. Com-

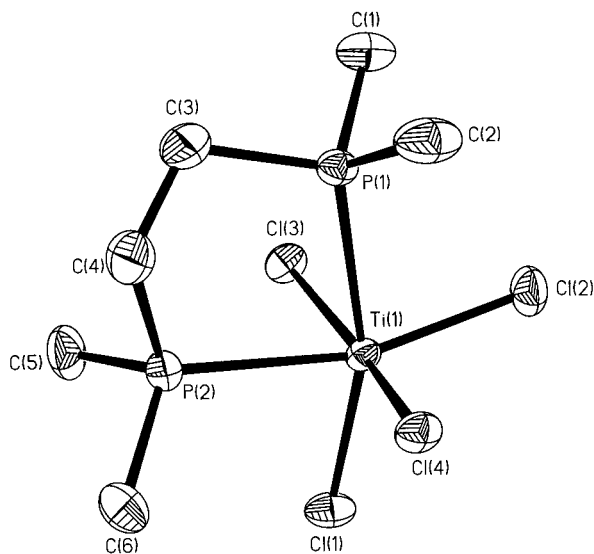

Fig. 1. A drawing of one independent  $\text{TiCl}_4(\text{dmpe})$  molecule showing the atom labeling scheme. Atoms are represented by their thermal ellipsoids at 40% probability level. Hydrogen atoms are omitted for clarity.

compound **3** crystallizes in the tetragonal space group  $I4/a$  with sixteen molecules per unit cell. The complexes have similar structures with a distorted octahedral arrangement of ligands around the  $\text{Ti}^{\text{IV}}$  atom. Molecules of **2** and **3** contain a chelating diphosphine ligand, which is crystallographically disordered in both cases. Six-coordination is achieved by one benzyl group and three chloride ions in **2**, and by two benzyl groups and two chlorine atoms in **3**. Perspective views of the molecular structures of **2** and **3** are shown in Figs. 2 and 3, respectively. Selected bond distances and angles are listed in Table 2.

Table 2  
Selected bond distances (Å) and angles (deg.) in **1–3**

	$\text{TiCl}_4(\text{dmpe})^*$ <b>1</b>		$\text{TiCl}_3(\text{PhCH}_2)(\text{dmpe})$ <b>2</b>	$\text{TiCl}_2(\text{PhCH}_2)_2(\text{dmpe})$ <b>3</b>
	(a)	(b)		
Ti–Cl(1)	2.273(2)	2.277(2)	2.357(1)	2.3314(7)
Ti–Cl(2)	2.288(2)	2.280(2)	2.329(1)	2.3330(7)
Ti–Cl(3)	2.307(2)	2.309(2)	2.329(1)	
Ti–Cl(4)	2.293(2)	2.285(2)		
Ti–P(1)	2.582(2)	2.590(2)	2.583(1)	2.6312(9)
Ti–P(2)	2.577(2)	2.574(2)	2.586(2)	2.6486(9)
P(1)–Ti–P(2)	75.95(6)	75.45(6)	76.83(5)	73.84(2)
Ti–C(1)			2.204(4)	2.188(3)
Ti–C(2)			2.464(4)	2.605(2)
Ti–C(8)				2.213(2)
Ti–C(1)–C(2)			81.9(2)	88.9(2)
Ti–C(8)–C(9)				124.9(2)

\* Two independent molecules.

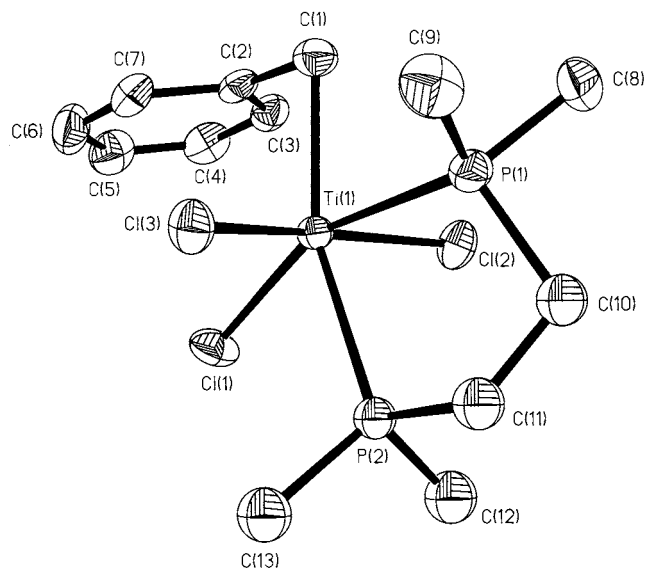

Fig. 2. Perspective drawing of the  $\text{TiCl}_3(\text{PhCH}_2)(\text{dmpe})$  molecule showing the atom labeling scheme. Atoms are represented by their thermal ellipsoids at 40% probability level. Hydrogen atoms are omitted for clarity.

Of most interest in structures **2** and **3** are the coordination characteristics of the benzyl groups. In **2**, the single benzyl group is bent towards the titanium atom with a  $\text{Ti–C(1)–C(2)}$  angle of  $81.9(2)^\circ$ . This results in the close proximity of the phenyl ring to the titanium atom (Fig. 4). The  $\text{Ti–C(2)}$  distance is  $2.464(4)$  Å;  $\text{Ti–C(1)}$  is  $2.202(4)$  Å.

In the crystal structure of **3** the two benzyl groups are nonequivalent. The first one, bound through C(1), has an acute  $\text{Ti–C(1)–C(2)}$  angle of  $88.9(2)^\circ$  and a  $\text{Ti–C(2)}$  distance of  $2.605(2)$  Å. This contrasts to the value of  $124.0(2)^\circ$  for the second benzyl group bound to  $\text{Ti}^{\text{IV}}$  through C(8).

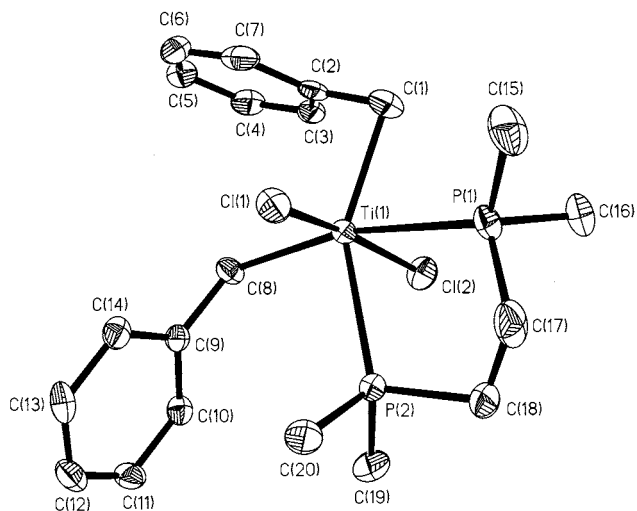

Fig. 3. A drawing of the molecular structure of  $\text{TiCl}_2(\text{PhCH}_2)_2(\text{dmpe})$  showing the atom labeling scheme. Atoms are represented by their thermal ellipsoids at 40% probability level. Hydrogen atoms are omitted for clarity.

### 3.1.3. $[\text{TiCl}_2(\mu\text{-Cl})(\text{dmpe})_2]_2$ (**4a**) and $[\text{TiCl}_2(\mu\text{-Cl})(\text{depe})_2]_2$ (**4b**)

Compound **4a** crystallizes in the monoclinic space group  $P2_1/n$  with two molecules in the unit cell, while **4b** conforms to the orthorhombic space group  $Pca2_1$ <sup>2</sup> with four molecules per unit cell. Both complexes con-

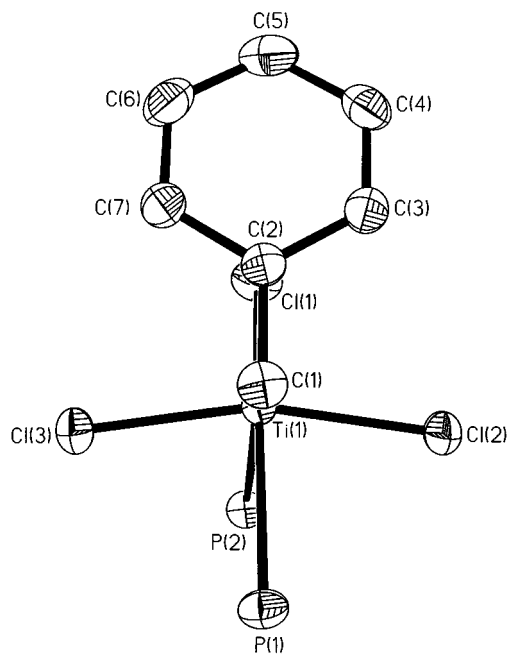

Fig. 4. View of the  $\text{TiCl}_3\text{P}_2(\text{CH}_2\text{Ph})$  unit in **2**. Hydrogen and carbon atoms C(8)–C(18) are omitted for clarity.

<sup>2</sup> An attempt to refine the structure in the centrosymmetric space group  $Pbcm$  was unsuccessful; crystals were likely racemic twins as the solution proceeded well using a TWIN refinement in the space group  $Pca2_1$  (the BASF parameter was ca. 0.5).

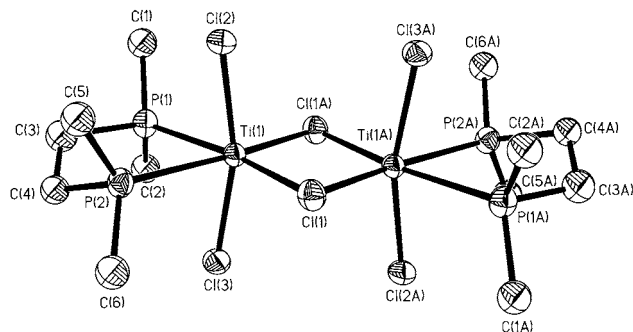

Fig. 5. Perspective drawing of the  $[\text{Ti}(\mu\text{-Cl})_2\text{Cl}_2(\text{dmpe})_2]$  molecule showing the atom labeling scheme. Atoms are represented by their thermal ellipsoids at 40% probability level. Hydrogen atoms are omitted for clarity.

sist of discrete dinuclear chloride-bridged titanium units of composition  $[\text{TiCl}_2(\mu\text{-Cl})(\text{PP})_2]_2$  (PP = dmpe and depe, respectively). The chelating diphosphines are crystallographically disordered in **4a** and **4b**. The dinuclear molecule **4a** possesses a crystallographically imposed inversion center, and closely approaches ideal  $D_{2h}$  symmetry. In **4b** the titanium atoms are crystallographically independent. Both dinuclear compounds are composed of two edge-sharing octahedra in which each  $\text{Ti}^{\text{III}}$  center has a distorted octahedral environment. The molecular drawings of **4a** and **4b** are shown in Figs. 5 and 6, respectively. Selected bond lengths and angles are listed in Table 3 and compared to those reported in the literature [12] for an analogous  $[\text{TiCl}_2(\mu\text{-Cl})(\text{dippe})_2]$  compound (dippe =  $\text{Pr}_2\text{PC}_2\text{H}_4\text{PPr}_2$ ). All three complexes correspond to the 1,3,5,7-type of isomer [13] with the diphosphine groups being equatorial.

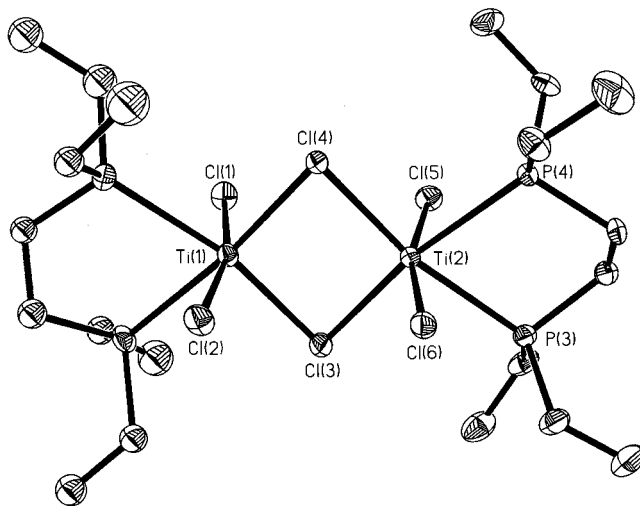

Fig. 6. Perspective drawing of the  $[\text{Ti}(\mu\text{-Cl})_2\text{Cl}_2(\text{depe})_2]$  molecule showing the atom labeling scheme. Atoms are represented by their thermal ellipsoids at 40% probability level. Hydrogen atoms are omitted for clarity.

Table 3

Selected bond distances (Å) and angles (deg.) in  $Ti_2(\mu-Cl)_2Cl_4(PP)_2$  compounds (PP = dmpe, depe, dippe)

	dmpe 4a	depe* 4b	dippe [12]
Ti···Ti	3.121(2)	3.2138(9)	3.438(2)
Ti–Cl <sub>br</sub>	2.437(2)	2.439(1)	2.459(4)
Ti–Cl <sub>br'</sub>	2.444(2)	2.441(1)	2.462(4)
Ti–Cl <sub>term</sub>	2.311(2)	2.326(1)	2.310(4)
Ti–Cl <sub>term'</sub>	2.339(2)	2.330(1)	2.313(4)
Ti–P(1)	2.581(2)	2.604(1)	2.645(5)
Ti–P(2)	2.581(2)	2.610(1)	2.658(5)
P(1)–Ti–P(2)	78.71(6)	78.37(4)	78.6(2)
Ti–Cl <sub>br</sub> –Ti	79.49(6)	82.37(4)	88.6(1)
Cl <sub>br</sub> –Ti–Cl <sub>br'</sub>	100.51(6)	97.63(4)	91.4(1)
Cl <sub>t</sub> –Ti–Cl <sub>t</sub>	164.77(7)	166.34(5)	169.6(2)

\* Averaged for two titanium octahedra.

### 3.1.4. $[Ti(\mu-Cl)Cl(dmpe)]_3 \cdot C_7H_8$ (**5** · $C_7H_8$ )

Compound **5** ·  $C_7H_8$  crystallizes in the trigonal space group  $R\bar{3}c$  with six trinuclear molecules per unit cell; the interstitial toluene molecule is crystallographically disordered. The molecular structure of one enantiomorphous molecule of **5** is shown in Fig. 7. The molecule has  $C_3$  symmetry and there are equal numbers of the two enantiomorphs in the unit cell. Three  $Ti^{II}$  atoms are bridged by three chloride ligands (Ti–Cl<sub>br</sub> 2.436(2) Å), forming a  $Ti_3(\mu-Cl)_3$  core. Each titanium atom has a chelating diphosphine ligand, dmpe, with Ti(1)–P(1) and Ti(1)–P(2) distances of 2.656(3) and 2.598(3) Å (Table 4), respectively, and an angle P(1)–Ti–P(2) of 76.87(9)°. In addition, there is one terminal chlorine atom (Ti–Cl<sub>term</sub> 2.401(3) Å) per titanium atom; the Ti–Ti distance is 2.872(3) Å.

### 3.2. Synthetic considerations

The dmpe adduct of  $TiCl_4$  was prepared in practically quantitative yield by stoichiometric addition of phosphine to a solution of titanium tetrachloride in hexanes. An excess of dmpe has been shown [2] to yield the eight-coordinate complex  $TiCl_4(dmpe)_2$ .

We have found that the six-coordinate complex  $TiCl_4(dmpe)$  (**1**) can be easily alkylated by reaction with a stoichiometric amount of the corresponding Grignard reagents according to Eq. (1a) and Eq. (1b):

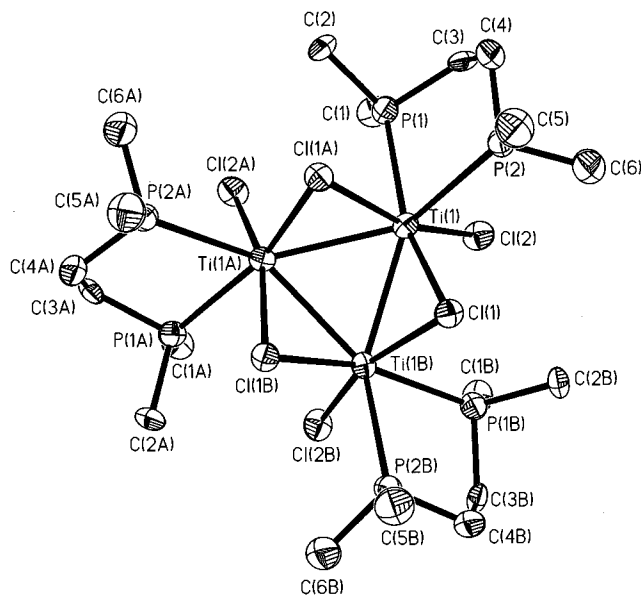
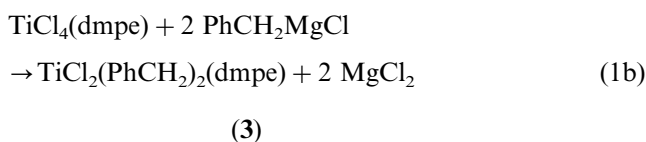
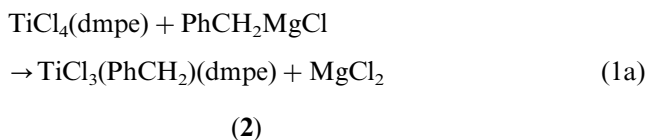

Fig. 7. Perspective drawing of the trinuclear  $[Ti(\mu-Cl)Cl(dmpe)]_3$  cluster showing the atom labeling scheme. Atoms are represented by their thermal ellipsoids at 40% probability level. Hydrogen atoms are omitted for clarity.

Compounds (**2**) and (**3**) have been obtained in good yields and have been crystallographically characterized (*vide supra*). Both are stable as solids at room temperature under an inert atmosphere but must be kept below 0°C while in solution; toluene solutions containing (**2**) and (**3**) quickly decompose at room temperature.

Structures of both  $TiCl_3(PhCH_2)(dmpe)$  (**2**) and  $TiCl_2(PhCH_2)_2(dmpe)$  (**3**) provide interesting examples of benzyl ligands bending toward the electron deficient  $Ti^{IV}$  center. The Ti–C(1)–C(2) angle of 81.9(2)° in **2** is well below the ideal tetrahedral value 109.5° and significantly smaller than the value of 88.9(2)° in **3** (an angle Ti–C(8)–C(9) for the second benzyl group in **3** is 124.9(2)°). The driving force for this quasi- $\pi$  type interaction is the tendency of the  $Ti^{IV}$  atom to acquire a share in more than just the two electrons that would constitute a simple Ti–C sigma bond. It is thus related

Table 4

Selected bond distances (Å) and angles (deg.) in **5**

Ti(1)–Ti(1A)	2.872(3)		
Ti(1)–Cl(1)	2.436(3)	Ti(1)–P(1)	2.656(3)
Ti(1)–Cl(2)	2.401(3)	Ti(1)–P(2)	2.598(3)
Cl(1)–Ti(1)–Cl(2)	103.99(9)	Cl(1)–Ti(1)–P(1)	161.1(1)
Cl(1A)–Ti(1)–Cl(2)	162.4(1)	Cl(1A)–Ti(1)–P(1)	161.1(1)
Cl(1)–Ti(1)–Cl(1A)	92.2(1)	Cl(1)–Ti(1)–P(2)	84.77(9)
P(1)–Ti(1)–P(2)	76.87(9)	Cl(1A)–Ti(1)–P(2)	88.22(8)
Ti(1)–Cl(1)–Ti(1)	72.27(9)	Cl(2)–Ti(1)–P(1)	79.59(9)
		Cl(2)–Ti(1)–P(2)	86.3(1)

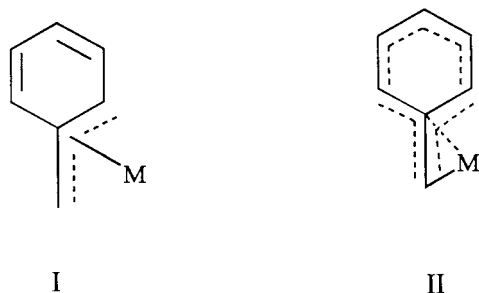

Scheme 1.

to, though different from, the  $\beta$ -H interaction found previously in  $\text{TiCl}_3(\text{C}_2\text{H}_5)(\text{dmpe})$  [14], where the Ti–C–C angle is  $86.3(6)^\circ$ . The type of Ti–benzyl interaction seen in **2** and **3** was found for the first time [15] in the compounds  $\text{M}(\text{PhCH}_2)_4$ , M = Ti, Zr, Hf.

It may be noted that the enhanced interaction of a benzyl group with an electron deficient metal atom is actually known to occur in two related but distinct ways. Even earlier than the observations on the  $\text{M}(\text{PhCH}_2)_4$  molecules, it was found that in  $(p\text{-CH}_3\text{C}_6\text{H}_4\text{CH}_2)(\eta^5\text{-C}_5\text{H}_5)\text{Mo}(\text{CO})_2$  [16] there is a structure of the type shown as I in Scheme 1. Here the metal atom engages in the formation of a  $\eta^3$ -allyl bond and seriously affects the bonding in the phenyl ring, so that there is a marked alternation in the C–C bond lengths, which are in two ranges, 1.33–1.36 and 1.42–1.43 Å. The relationship of the Ti atom to the benzyl group in compounds **2** and **3**, as well as in the  $\text{M}(\text{PhCH}_2)_4$  compounds is as shown in structure II of Scheme 1. It can be characterized by a strong Ti–C(1)  $\sigma$  interaction together with secondary interaction involving C(2) and probably C(3) and C(7) part of  $\pi$ -system. As shown in Fig. 4 for complex **2** the two distances Ti–C(3) and Ti–C(7) are nearly identical (3.068(4) and 3.076(4) Å, respectively). In addition, the C(2)–C(3) and C(2)–C(7) distances (averaged to 1.400(6) Å in **2**, and to 1.405(4) Å in **3**) are just a bit longer than other C–C bond lengths in aromatic rings (average 1.371(6) Å in both **2** and **3**). Other four- [17] and five-coordinate [18] titanium-benzyl compounds have also been shown to exhibit the same type of so-called ‘benzallyl’ distortions. To our knowledge, complexes **2** and **3** (formally 12 electron species) are the first examples containing this distortion among six-coordinate  $\text{Ti}^{\text{IV}}$  compounds. The value of  $81.9(2)^\circ$  for the Ti–C–C angle in **2** is the smallest so far reported; even those in the tetrahedral  $\text{Ti}(\text{PhCH}_2)_4$  complex are larger ( $88(2)^\circ$  for the room temperature experiment ([15]b), and  $92(1)^\circ$  at  $-40^\circ\text{C}$  [15]a) ( $88(2)^\circ$ , ... ([15]b), ... ([15]a)).

In an effort to make *tert*-butyl analogues of compounds **2** and **3**, reactions analogous to Eq. (1a) and Eq. (1b) were undertaken. When a toluene solution containing **1** was reacted with *one* equivalent of  $\text{Bu}^t\text{MgCl}$  at  $-20^\circ\text{C}$  the only product isolated was a dinuclear  $\text{Ti}^{\text{III}}$  complex,  $[\text{TiCl}_2(\mu\text{-Cl})(\text{dmpe})_2]$  (**4a**). This compound can

be synthesized in higher yield by direct reaction of  $\text{TiCl}_3(\text{THF})_3$  with dmpe in toluene according to the procedure used for the preparation of dippe analogue [12]. For comparison, we also prepared the depe analogue **4b** following the above procedure.

An X-ray crystal structure determination of **4a** reveals an octahedral geometry about each  $\text{Ti}^{\text{III}}$  center and a Ti···Ti distance of 3.121(2) Å (Fig. 5). Corresponding metal-metal distances for the analogous  $[\text{TiCl}_2(\mu\text{-Cl})(\text{depe})_2]$  (**4b**) and  $[\text{TiCl}_2(\mu\text{-Cl})(\text{dippe})_2]$  [12] were found to be longer, namely 3.2138(9) and 3.438(2) Å, respectively. As expected for geometric reasons the Ti–Cl<sub>br</sub>–Ti angles increase from  $79.49(6)$  to  $88.6(1)^\circ$ , and the Cl<sub>br</sub>–Ti–Cl<sub>br</sub> angles decrease from  $100.51(6)$  to  $91(4)^\circ$  on going from the dmpe to the dippe compound (Table 3).

Although the Ti···Ti contact is substantially shorter in **4a** than those of other chloride-bridged  $\text{Ti}^{\text{III}}$  dimers, a magnetic moment of  $1.04 \mu_B$  per titanium center indicates there is little or no direct titanium–titanium bonding in **4a**. It is worth noting that these data for three structurally similar complexes  $[\text{TiCl}_2(\mu\text{-Cl})(\text{PP})_2]$  (PP = dmpe, depe, dippe) provides a good example of how the structure is influenced by the ligand size: the more bulky phosphine ligand results in the longer Ti···Ti distance (more than a 0.3 Å difference between the dmpe and dippe analogues).

When a  $\text{TiCl}_4(\text{dmpe})$  solution in toluene was treated with *two* equivalents of  $\text{Bu}^t\text{MgCl}$  a  $\text{Ti}^{\text{II}}$  compound,  $[\text{Ti}(\mu\text{-Cl})\text{Cl}(\text{dmpe})_3]$  (**5**) was isolated; it is relatively stable in crystalline form but solutions maintained at room temperature quickly decompose as indicated by changing features in the NMR spectra<sup>3</sup>. The reactivity towards air is also very high, even in the solid state; crushed crystals are pyrophoric and slowly decompose on standing in an argon dry box at room temperature.

The cluster molecule **5** consists of an equilateral triangle of  $\text{Ti}^{\text{II}}$  atoms with three coplanar  $\mu\text{-Cl}$  atoms bridging the edges. Each titanium atom is further coordinated by a chelating dmpe and a chloride ion (Fig. 7). The short Ti–Ti separation of 2.872(3) Å in **5** is about 0.2 Å greater than the sum of the Pauling  $R_1$  radii (2.648 Å). With the short Ti–Ti distances found in **5**, the molecule would be expected to be diamagnetic, but a residual paramagnetism, even in the solid state, was observed. Because of the extreme instability of the compound, we presume this is the result of impurities formed during the measurement process.

<sup>3</sup> The  $^{31}\text{P}\{^1\text{H}\}$  NMR spectrum of crystals  $\mathbf{5} \cdot \text{C}_7\text{H}_7$  in  $\text{C}_6\text{D}_6$  ( $20^\circ\text{C}$ , 121.4 MHz) exhibits a singlet at  $-47.8$  ppm, which resembles that of the free phosphine ( $-48.07$  ppm). The  $^1\text{H}$  NMR spectrum at room temperature in  $\text{C}_6\text{D}_6$  confirms the presence of an interstitial toluene molecule (2.09(5) ppm); it also shows that phosphine dissociation occurs as part of some decomposition processes. Unfortunately, the limited solubility of **5** in toluene as well as its instability in solutions prevented the collection of low-temperature NMR data.

The only previously reported compound [19] that bears any resemblance to **5** is  $\text{Ti}_7\text{Cl}_{16}$  (and, to a lesser extent,  $\text{Ti}_7\text{Br}_{16}$ ). This mixed valence compound contains an array of fused  $\text{Ti}^{\text{IV}}\text{Cl}_6$  octahedra and  $\text{Ti}_3^{\text{II}}\text{Cl}_{13}$  units in a 1:2 ratio. Within the  $\text{Ti}_3\text{Cl}_{13}$  units there are Ti–Ti distances of about 2.954(2) Å that may be presumed to correspond to Ti–Ti single bonds. In this case the  $\text{Ti}_3^{\text{II}}$  unit is encapsulated in a solid state environment and also has a capping ( $\mu_3\text{-Cl}$ ) atom in addition to three edge bridges.

Examples of  $\text{Zr}^{\text{III}}\text{–Zr}^{\text{III}}$  and  $\text{Hf}^{\text{III}}\text{–Hf}^{\text{III}}$  bonds are well known. Representative compounds for zirconium are  $\text{Zr}_2\text{Cl}_6(\text{dppe})_2$ ,  $\text{Zr}_2\text{Cl}_6(\text{PMe}_2\text{Ph})_4$  and  $\text{Zr}_2\text{Cl}_6(\text{PET}_3)_4$ , in which the Zr–Zr distances range from 3.104(5) to 3.169(1) Å [20], which are 0.10 to 0.16 Å longer than  $2 \times R_1$ . Similarly, in the hafnium compounds  $\text{Hf}_2\text{Cl}_6(\text{dippe})_2$  [21] and  $\text{Hf}_2\text{Cl}_6(\text{PMe}_2\text{Ph})_4$  [22] the Hf–Hf distances are 3.099(1) Å and 3.0886(3) Å, respectively ( $2 \times R_1 = 2.884$ ). While there might have been some hesitation in assigning Zr–Zr and Hf–Hf bonds because of these distances being 0.10 to 0.20 Å greater than the values of  $2 \times R_1$  for the metal atoms, a theoretical study supported [23] such an assignment.

By contrast, as already noted, titanium compounds of the same type, such as **4** have relatively longer Ti···Ti distances (3.121(2) in **4a** versus  $2 \times R_1 = 2.448$  Å, giving an excess of 0.67 Å) and are paramagnetic. Other examples of  $\text{Ti}^{\text{III}}\text{–Ti}^{\text{III}}$  bonds are scarce; the only known examples are found [24] in complexes of the type  $\text{Ti}_2(\text{RNC}(\text{H})\text{NR})_2(\mu\text{-RNC}(\text{H})\text{NR})_2(\mu\text{-Cl})_2$  with the Ti–Ti distances of *ca.* 2.9 Å.

There are a few other cases where Ti···Ti distances of 3.110 Å [25], 2.75–2.78 Å [26] and 2.745 Å [27] have been reported, but these are of uncertain structure, of very complex structure, or contain strongly constraining bridges, respectively.

It is noteworthy that in contrast to the benzyl-containing  $\text{Ti}^{\text{IV}}$  complexes **2** and **3**, *tert*-butyl-substituted titanium analogues of the type ' $\text{TiCl}_{4-n}\text{Bu}'_n(\text{dmpe})$ ',  $n = 1, 2$  have not been isolated under similar conditions. They are thermally unstable and attempts to prepare them lead instead to the formation of dinuclear and trinuclear titanium chloride-phosphine molecules **4** and **5**, respectively. The weak intramolecular interaction between the aromatic ligand and  $\text{Ti}^{\text{IV}}$  found in **2** and **3** could account for the enhanced stability of the titanium benzyls compared to that of the corresponding alkyls. This interaction in **2** was found to be the most prominent (as measured by the angle Ti–C(1)–C(2)) in the titanium-benzyl compounds.

In summary, compound **5** is the first molecular titanium cluster compound of any kind, the first example of  $\text{Ti}^{\text{II}}\text{–Ti}^{\text{II}}$  bonding and a rare example of a relatively thermally stable, though pyrophoric,  $\text{Ti}^{\text{II}}$  compound in the solid state; however, in solution it quickly decomposes.

#### 4. Supplementary material available

Crystallographic data for compounds **1–5** have been deposited with the Cambridge Crystallographic Data Centre (entities carrying the suffix *x* represent dummy atoms used for modeling disordered atoms). Copies of the data can be obtained free of charge on application to The Director, CCDC, 12 Union Road, Cambridge CB2 1EZ, UK (Fax: +44 1223 336033; e-mail: deposit@chemcryst.cam.ac.uk).

#### Acknowledgements

We thank the Robert A. Welch Foundation support through Grant No. A494 and the Vicerrectoría de Investigación U.C.R. (Project 115-87-516). We thank Dr E.V. Dikarev for assistance with X-ray crystallography.

#### References

- [1] F.A. Cotton, R.A. Walton, Multiple Bonds between Metal Atoms, 2nd ed., Oxford University Press, New York, 1993.
- [2] F.A. Cotton, J.H. Matonic, C.A. Murillo, M.A. Petrukhina, *Inorg. Chim. Acta* 267 (1998) 173; and references therein.
- [3] M. Bochmann, in: E.W. Abel, F.G. Stone, G.W. Wilkinson (Eds), *Comprehensive Organometallic Chemistry II*, vol. 4, chapter 5, Pergamon, New York, 1995.
- [4] G.W.A. Fowles, R.A. Walton, *J. Chem. Soc. A* (1967) 4330.
- [5] M.A. Araya, F.A. Cotton, J.H. Matonic, C.A. Murillo, *Inorg. Chem.* 34 (1995) 5424.
- [6] J.A. Jensen, S.R. Wilson, A.J. Schultz, G.S. Girolami, *J. Am. Chem. Soc.* 109 (1987) 8094.
- [7] R. Morres, G.S. Girolami, *Inorg. Chem.* 29 (1990) 4169.
- [8] (a) A. Bino, F.A. Cotton, P.E. Fanwick, *Inorg. Chem.* 18 (1979) 3558. (b) F.A. Cotton, B.A. Frenz, G. Deganello, A. Shaver, *J. Organomet. Chem.* 50 (1973) 227. (c) F.A. Cotton, E.V. Dikarev, X. Feng, *Inorg. Chim. Acta* 237 (1995) 19.
- [9] R.H. Blessing, *Acta Cryst. A* 51 (1995) 33.
- [10] SHELXTLV.5, Siemens Industrial Automation Inc., Madison, WI, 1994.
- [11] G.M. Sheldrick, in: H.D. Flack, L. Parkanyi, K. Simon (Eds), *Crystallographic Computing 6*, Oxford University Press, Oxford, UK, 1993, pp.111–122.
- [12] A.R. Hermes, G.S. Girolami, *Inorg. Chem.* 29 (1990) 313.
- [13] F.A. Cotton, E.V. Dikarev, M.A. Petrukhina, *J. Am. Chem. Soc.* 119 (1997) 12541.
- [14] Z. Dawoodi, M.L.H.Green, V.S.B. Mtetwa, K. Prout, A.J. Schultz, J.M. Williams, T.F. Koetzle, *J. Chem. Soc. Dalton Trans.* (1986) 1629.
- [15] (a) G.R. Davies, J.A.J. Jarvis, J.B.T. Kilbourn, *Chem. Soc. Chem. Commun.* (1971) 1511. (b) I.W. Bassi, G. Allegra, R. Scordamaglia, *J. Am. Chem. Soc.* 93 (1971) 3787.
- [16] F.A. Cotton, M.D. LaPrade, *J. Am. Chem. Soc.* 90 (1968) 5418.
- [17] L.M. Alvaro, T. Cuenca, J.C. Flores, P. Royo, M.A. Pellinghelli, A. Tiripicchio, *Organometallics* 11 (1992) 3301.
- [18] H. Stoeckli-Evans, *Helv. Chim. Acta.* 58 (1975) 93.
- [19] B. Krebs, G. Henkel, *Z. anorg. allg. Chem.* 474 (1981) 149.
- [20] F.A. Cotton, M.P. Diebold, P.A. Kibala, *Inorg. Chem.* 27 (1988) 799.



- [21] P.M. Morse, S.R. Wilson, G.S. Girolami, *Inorg. Chem.* 29 (1990) 3200.
- [22] F.A. Cotton, P.A. Kibala, W.A. Wojtczak, *Inorg. Chim. Acta* 177 (1990) 1.
- [23] M.-M. Rohmer, M. Bénard, *Organometallics* 10 (1991) 157.
- [24] (a) F.A. Cotton, W.A. Wojtczak, *Gazz. Chim. Ital.* 123 (1993) 499.  
(b) S. Hao, K. Feghali, S. Gambarotta, *Inorg. Chem.* 36 (1997) 1745.
- [25] P. Corradine, A. Sirigu, *Inorg. Chem.* 6 (1967) 601.
- [26] S.I. Troyanov, V.A. Tafeenko, *Zhur. Obsh. Khim.* 60 (1989) 2416.
- [27] F. Gauvin, J. Britten, E. Samuel, J.F. Harrod, *J. Am. Chem. Soc.* 114 (1992) 1489.