

J. W. WEBB.
Straw Cutter.

No. 4,378.

Patented Feb. 10, 1846.

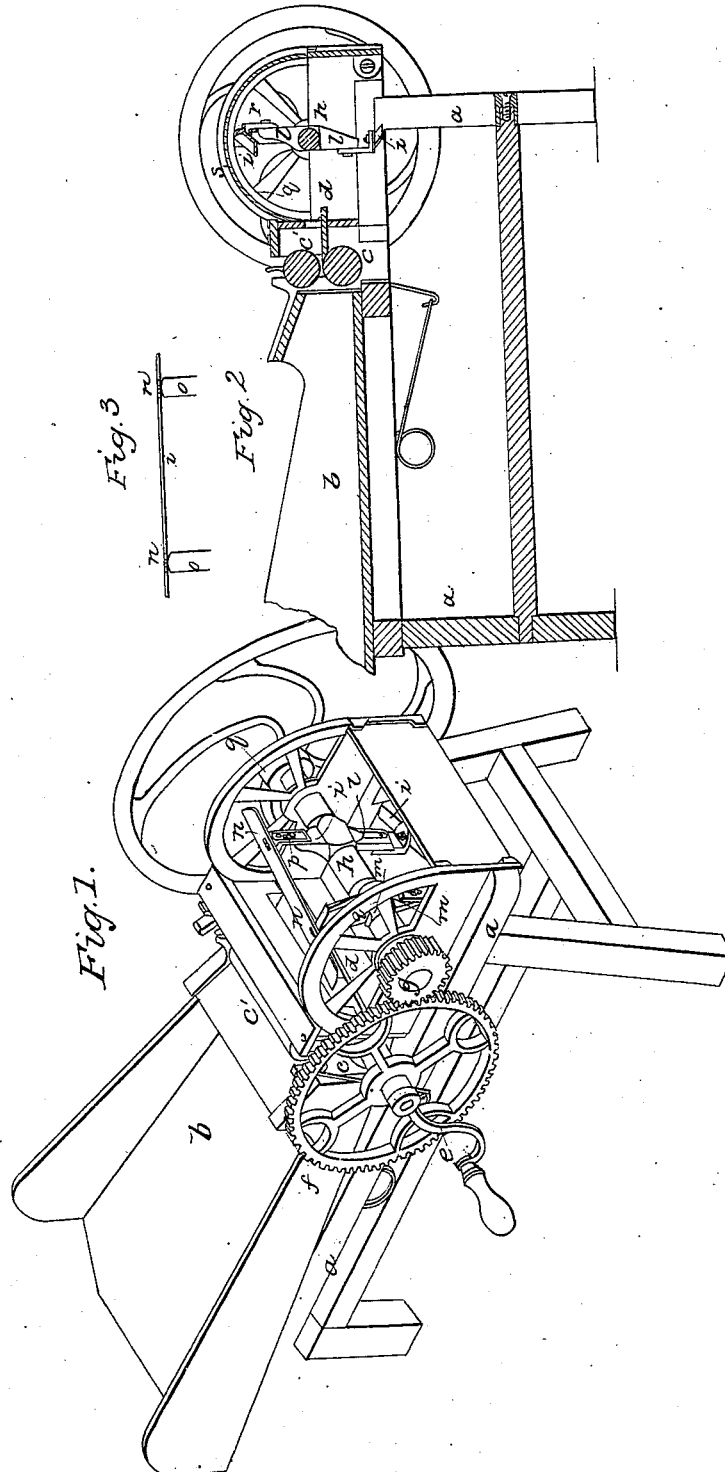

UNITED STATES PATENT OFFICE.

J. W. WEBB, OF LOCKPORT, NEW YORK.

STRAW-CUTTER.

Specification of Letters Patent No. 4,378, dated February 10, 1846.

To all whom it may concern:

Be it known that I, JOSEPH W. WEBB, of Lockport; in the county of Niagara and State of New York, have invented a new and useful Improvement in Straw-Cutters, and that the following is a full, clear, and exact description of the principle or character thereof which distinguishes it from all other things before known and of the manner of making, constructing, and using the same, reference being had to the accompanying drawings, making part of this specification, in which—

Figure 1 is a perspective view; and Fig. 2, a vertical longitudinal section.

The same letters in all the figures indicate like parts.

In a straw cutter secured to me by Letters Patent bearing date the 2nd day of July in the year 1842, in which the knives, straight on the cutting edge and face, are connected with the shaft or stock, with the cutting edges on a line diagonal therewith and the outer face on tangents, so that that end which first commences the cut is tangential to a smaller diameter than the other, or in other words, in which the faces of the knives are tangential to a cone, for purposes fully expressed in the Letters Patent before cited, experience has shown the importance of having them so connected with the stock or shaft as to admit of adjustment as their cutting edges wear, for it is evident that as the cutting edge wears away its diameter decreases, and will not act against the bed cutter at the end of the box, and therefore it becomes necessary to attach them to adjustable arms, which, by means of screw bolts and elongated holes or slots, will admit of the adjustment of the edge of the knives to the edge of the bed cutter or shear; but as the wear from inequality in the texture of the metal, or unequal grinding, is irregular, it frequently occurs that one end must be moved out more than the other, which bends the knives, if secured to flat faces or seats on the ends of the arms to which they are attached, and vary their cutting line; and therefore, to avoid this defect, the ends of the arms, or the faces to which the knives are attached are beveled on each side, so that they (the knives) rest on the

ridges thus formed, and admit of easy adjustment without the liability of bending.

In the accompanying drawings (*a*) is the frame, (*b*) the box, (*c c'*) the feed rollers, and (*d*) the bed cutter or shear, made in the usual manner.

The crank (*e*) for driving the machine by manual power is attached to the shaft of the lower feed roller (*c*), and on this same shaft there is a large cog-wheel (*f*) which communicates motion to a pinion (*g*) on the shaft (*h*) of the cutting knives (*i i*), the said shaft having a fly wheel (*k*) on the other end to regulate the momentum. The shaft (*h*) has two sets of arms (*l, l*) (*m, m*), the axis of each set passes through the axes of the shaft and project equally on either side. These two sets of arms are not in the same plane, but intersect each other at an angle of about ten degrees, more or less, and the set (*m, m*) are longer than the other, in consequence of that end of the knives, which first commences the cut, being connected with them and the faces of the knives being tangential to a cone.

The knives are secured by screws (*n*) that pass through elongated holes in the knives to permit them to adapt themselves to the inclination required, for without this when one end of the knives is carried out the screw would bind and bend the knife—this is more fully represented in Fig. 3 which represents the knife secured to the two bevel faces of the flanch pieces (*o*) connected with the arms (*l, l*) (*m, m*) by screwbolts (*p*) that pass through elongated holes or slots in the flanch pieces (*o*), and screw into arms, so that by loosening these screw bolts the edge of the knives can be adjusted to the edge of the bed knife or shear with the greatest nicety, the double bevel on the face of the flanch pieces (*o*) (which are in fact prolongations of the arms), and the elongated holes permitting the knives to turn thereon and adapt themselves to any desired inclination.

The rotating knives are inclosed in a case formed by two circular end pieces (*q q*) opened, as represented in the drawings, for the free admission of air, as in a rotary fan blower, and a circular cap plate (*s*) Fig. 2 is put over the whole, so that the air which

enters through the apertures in the ends, by the centrifugal action of the arms and knives, assists them in throwing the cut straw down under the bed cutter instead of scattering it in all directions.

5 What I claim as my invention and desire to secure by Letters Patent is—

Attaching the knives to the bevel faces of the flanch pieces, to admit of their readily taking any inclination without bending, in

combination with the means of adjusting their cutting edge to the bed cutter or shear, by connecting the flanch pieces to which they are attached by screw bolts passing through elongated holes or slots, substantially as herein described. 15

JOSEPH W. WEBB.

Witnesses:

CHAS. M. KELLER,
MOSES PIERCE.