

LANGDON & SALISBURY.

Hemp Brake.

No. 4,469.

Patented April 25, 1846.

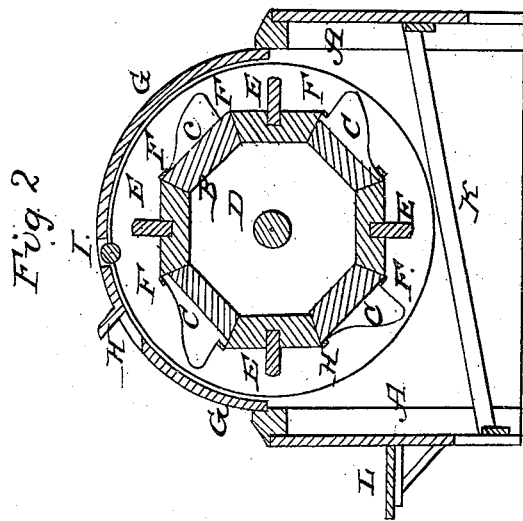
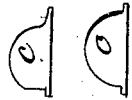
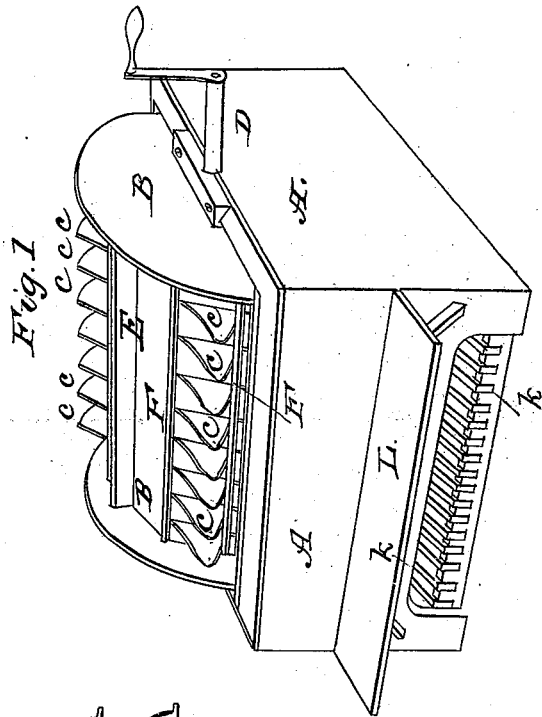

# UNITED STATES PATENT OFFICE.

BARNABAS LANGDON AND AMOS SALISBURY, OF TROY, NEW YORK.

## IMPROVEMENT IN HEMP-DRESSERS.

Specification forming part of Letters Patent No. 4,469, dated April 25, 1846.

*To all whom it may concern:*

Be it known that we, BARNABAS LANGDON and AMOS SALISBURY, of the city of Troy, in the county of Rensselaer and State of New York, have invented a new and useful Machine for Cleaning, Dressing, and Hatcheling Hemp and Flax and for other Purposes, which is described as follows, reference being had to the annexed drawings of the same, making part of this specification.

Figure 1 is a perspective view of the machine. Fig. 2 is a vertical section on the line *x x* of Fig. 1.

A frame, A, of suitable size, strength, and material, is constructed, having its sides closed in with thin boards. In this frame is placed a polygonal-shaped revolving drum, B, containing a number of knives, C, for passing through the hemp held by hand to them for cleaning and hatcheling it. This drum has a shaft, D, passing through its center, which turns in suitable boxes in the frame, on which there is a pulley around which passes a band leading to the driving-power. The circumference is generally divided into plain sections—say about twelve in number—into six of which are inserted rows of flat knives C, arranged in such manner that the knives in one row shall be opposite the spaces between the knives of the next succeeding row, and into the sections between those containing the cutters are inserted plain bars of wood, E, for breaking the hemp and flax, said bars being arranged parallel with the axis of the drum and at right angles with the planes of the cutters. The cutters *c* are made in the form of a semicircle, a quadrant, semi-oval, crescent, or other shape. They are let into grooves of corresponding width sawed into the lagging composing the sides or sections of the drum, and secured therein by strips F, of wood, fastened over their ends to the lagging parallel with the axis of the drum and with the beaters.

These strips also act as scrapers. The knives are generally made straight on their backs. The aforesaid drum is covered with a semi-circular cover, G, perforated with an oblong opening, H, through which the hemp and flax is introduced to the revolving cutters, being held by the hand of the attendant who manages it, so as to be subjected to the action of the knives in every part, the attendant allowing the flax to be drawn more or less into the case and withdrawing it again and turning over and over until it be completely dressed, the flax being directed toward the blades or knives by a roller, I, let into an oblong opening in the cover, in which it revolves when the flax is drawn over and against it. The drum should be caused to revolve at the rate of about two hundred revolutions per minute.

An inclined or concave grate, K, for catching the tow while the shives and dirt pass through below is arranged below the revolving drum and knives, said grate also serving to discharge the tow from the machine beneath a foot-board, L, arranged or placed at the rear side of the frame.

The before-described machine may be varied in size, proportion, and material to suit the views of the constructor and the purpose to which it is to be applied.

What we claim as our invention, and desire to secure by Letters Patent, is—

The combination of the knives and beaters constructed and arranged in the manner and for the purpose set forth, and, in combination therewith, the arrangement of the perforated cover, the roller, and the grate, in the manner and for the purpose set forth.

B. LANGDON.  
AMOS SALISBURY.

In presence of—  
ARCHIBALD BULL,  
GEO. DAY.