

Sheet 1, 2 Sheets.

T. & E. Burrel.

Straw Cutter.

N^o 6,700.

Patented Sept. 11, 1849.

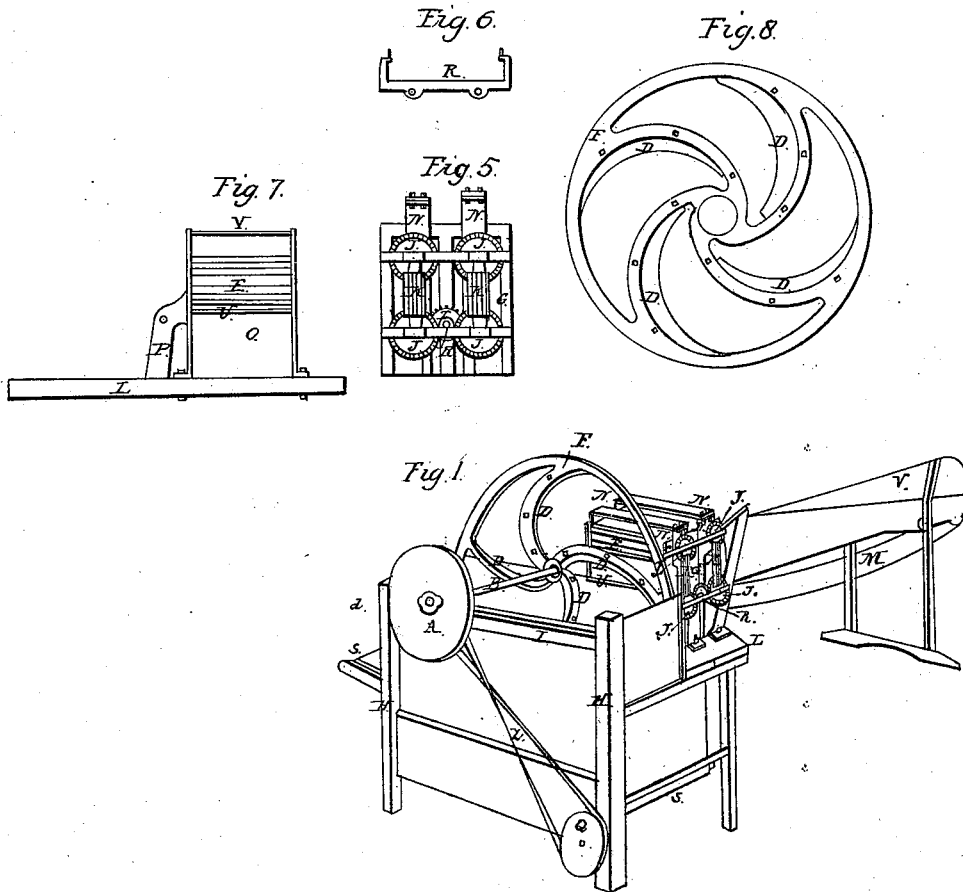

I. & E. Burrel

Straw Cutter

N^o 6, 406.

Patented Sept. 11, 1849.

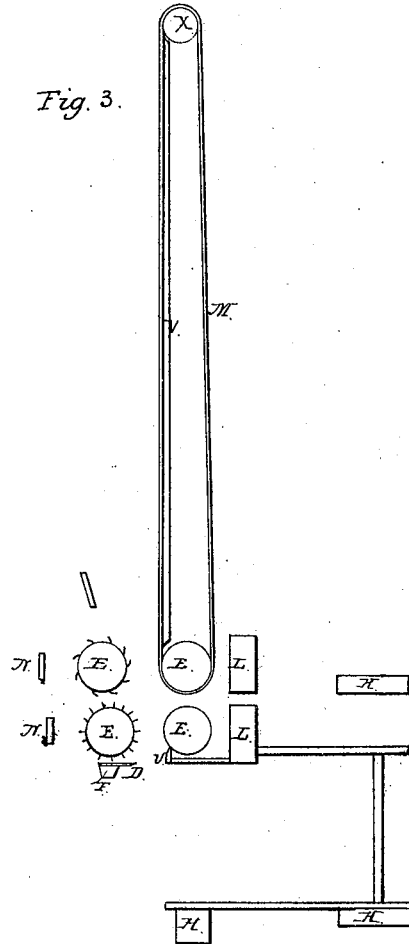
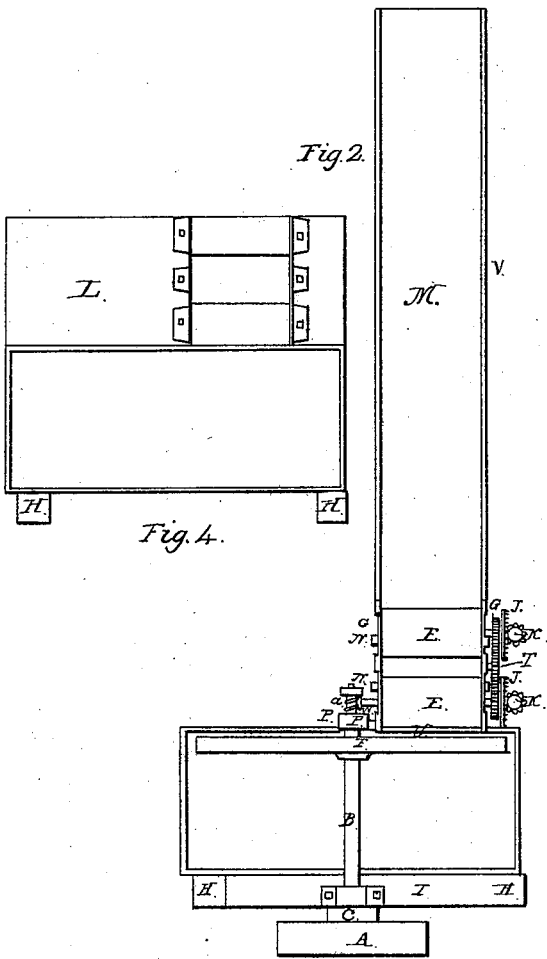

UNITED STATES PATENT OFFICE.

T. BURREL AND E. BURREL, OF SENECA, NEW YORK.

STRAW-CUTTER.

Specification of Letters Patent No. 6,706, dated September 11, 1849.

To all whom it may concern:

Be it known that we, THOMAS BURREL and EDWARD BURREL, of the town of Seneca, in the county of Ontario and State of New York, have invented new and useful improvements in machines commonly known by the name of "Straw-Cutters;" and we do hereby declare that the following is a full, clear, and exact description, reference being had to the accompanying drawings, making a part of this specification, in which—

Figure 1 is a perspective view Fig. 2, a horizontal section. Fig. 3 a vertical section. Fig. 4 a section through the box, exhibiting the plank or bed piece to which the machinery is attached. Fig. 5, is a side view showing the connection and working of the operative feeding parts. Fig. 6, is a detached part of Fig. 5. Fig. 7, an end view of the mouth of the cutting box and Fig. 8, is the cutting wheel.

The nature construction and operation of our invention is described as follows, the same letters of reference indicating the same parts in all the figures wherever they occur, viz:

We construct a frame with four posts; H, H, are the two front posts, and the two rear posts are placed under the bed piece L. These four posts are connected together by two ties at each end and side, the top ones square and the bottom ones broad, to hinder the frame from rocking. The front plate I, to the frame is about nine inches higher than the back plate or bed piece L, as shown in Figs. 1 and 3, the bed plank or plate L, being firmly bolted on the back part of the frame to the two end ties. The plank L, is about sixteen inches wide, and three or four inches thick. On it the machinery rests and to it are firmly bolted, first two side plates of iron G, at the proper distances from each other. Between these side plates are placed four rollers E, the journals of which pass through the said side plates and the side plates form bearings for the two lower rollers, and the journals of the two upper rollers E, go through long slits or mortises in the side plates G and pass through the slides N, these slides forming bearings for the two upper rollers, and working up and down in grooves in the flanges on the outside of the plates G, and these two upper rollers are raised up and down in these slides as the thickness of the

feed requires, and if their weight is not sufficient to press the sheet hard enough, weight may be added (in the machine made for our use the slides weight 56 lbs each making 112 lbs on the sheet) and the plates G are connected on the front end at the bottom by an iron plate O Fig. 7, on which are flanges on the back side at the ends and top, and is firmly bolted through the two side plates G and through the end flanges of the front plate O, the top of this front plate O, forms a bed for the steel bar or die U, which is firmly screwed to plate O, and nicely fitted to the bottom front roller to prevent anything from drawing in between them to choke the machine. At the top the side plates G are connected by a rod Y and on the left side is bolted the leg or bearing P, to the side plate G, Fig. 7, which forms a bearing to one end of the shaft B, the other end of this shaft resting on the front plate I, Fig. 2.

The balance wheel F Fig. 8 has on it four knives or cutters D. screwed to the arms of the wheel. The arms of the balance wheel being crooked enables the knives to slide on the face of the die in making a cut, as much as the heel of the knife is above the center of the axis, and by this means makes it cut more easily. The balance wheel F. hangs on the shaft B. and the knives cut close to the steel bar or die U. On the end of the shaft B is a screw or worm a. Fig. 2 which meshes into a small cog wheel on the end of the shaft W, Fig. 2, which turns the lower roller E. On the other end of the shaft W in rear of the cog wheel J. Fig. 2 is a wheel which drives the cog-wheel T and the wheel T meshes into another wheel on the rear of the cogwheel J. on the back bottom roller which drives and secures the back bottom roller. The two cog wheels J. on the lower rollers (Figs. 2 and 5) drive two cylinder cog or pinion wheels K. K. (Fig. 2) which drive the two cog wheels J. on the upper rollers. On the right hand plate on Fig. 5 are two crooked iron bars R. R. (see Fig. 6) bolted to the side plate, between which are placed the two pinions K. K. and between the lower bar R. and the side plate is placed the wheel T. the two lower rollers are smooth and the upper front roller has in it a number of iron plates projecting above its surface about a quarter of an inch, in the ordinary way, and the back top roller has 8 or 9 rows of spikes projecting about an inch, with their points

bent forward (Fig. 3) to make them discharge from the sheet as it passes through to the knives. On the back part of the plates G is attached a feeding box V. Figs. 1 and 3, 5 with a roller X. at the hind end of it. Around the bottom roller E and the roller X, is a belt M which carries the straw or stalks into the machine, and the four rollers carry it up to the knives steadily, without any slipping back when the knives strike it. 10 There is another belt *s s* driven by the strap Z, from the pulley C, to drive the small pulley Q and give motion to the endless apron (*s s*) which receives the cut stuff as it falls 15 from the knives and discharges it (the cut stuff) in the direction of (*d*) Fig. 1 into any proper receptacle.

This straw cutter may be propelled by steam, horse or manual power applied to the 20 main shaft B, in any of the known methods.

What we claim as new and useful and for which we desire to secure Letters Patent is—

1. The employment of four feeding rollers

in the manner herein described, the top hind rollers having spikes on its surface to hold 25 firmly the straw, &c., and the combination of the said four rollers to feed in the straw or stalks with a steady, uniform motion so that the action of the cutter wheel will not arrest the motion of the sheet of stalks, &c., 30 when fed into the knives however great the speed of the cutter wheel may be.

2. We claim the cylinder fluted pinion wheels K. K. in combination with the upper face cog wheels J. J. to allow the top rollers 35 to rise up and slide down when different thicknesses of stalks, &c., are fed into the cutters—this being a superior manner of gearing to accomplish this object, and avoid all breakage of cogs in the wheels for the 40 purposes set forth.

THOMAS BURREL.
EDWARD BURREL.

Witnesses:

J. BONESTEEL,
E. H. HURD.