

A. W. JOHNSON.  
Sewing-Machine Shuttle.

No. 109,414.

Patented Nov. 22, 1870.

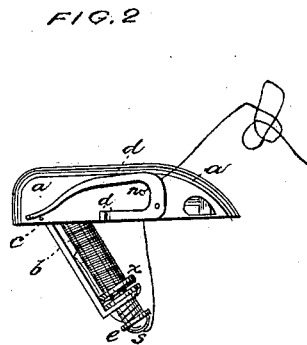
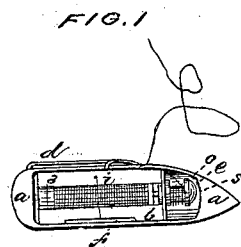

WITNESSES:

Wm. E. Simonds,  
S. J. Simonds.

INVENTOR:

Albert W. Johnson

# UNITED STATES PATENT OFFICE.

ALBERT W. JOHNSON, OF MIDDLETOWN, CONNECTICUT, ASSIGNOR TO THE  
FINKLE & LYON MANUFACTURING COMPANY, OF SAME PLACE.

## IMPROVEMENT IN SHUTTLES FOR SEWING-MACHINES.

Specification forming part of Letters Patent No. 109,414, dated November 22, 1870.

*To all whom it may concern:*

Be it known that I, ALBERT W. JOHNSON, of Middletown, in the county of Middlesex and State of Connecticut, have made certain Improvements in Sewing-Machine Shuttles, of which the following is a specification.

This invention relates to that class of sewing-machine shuttles which are provided with a cylinder for regulating the tension of the thread; and it consists in certain details of construction which will be fully described hereinafter.

In the accompanying drawings, Figure 1 is a view of the open side. Fig. 2 is a view of the outside of the shell, the bobbin being swung out of the same.

The outward shape and size of the shell of my shuttle are much the same as with those now in use.

The letter *a* indicates the metal shell of the shuttle; *b*, the metal bobbin-frame, hinged within the shell at *c*. *d* is the usual guard outside the shell.

The metal bobbin *x* slips in and out of the bobbin-frame, as is common with many bobbins now in use.

At the free end of the bobbin-frame a tension-cylinder, *e*, is attached. It runs through the end of the bobbin-frame, and has a collar or flange swaged upon it within this end, which holds the tension-cylinder *e* in place. This collar is not swaged on so tightly but that the tension-cylinder may be turned around one way or the other when desired.

One of the bearings of the bobbin rests in a center drilled in the center of the inner end of the tension-cylinder.

The thread is wound upon the bobbin in the usual manner. It then runs up through a slot, *f*, in the side of the bobbin-frame, across the frame down through the orifice *i* in the frame, then along to the free end of the frame through a hole in the same, then once or more around the tension-cylinder *e*, according to the tension desired, then down into a hole, *o*, in the cylinder and out of a hole, *s*, at the extreme end of the cylinder, then back to pass out of the hole *n* to the outside of the shell, and then on to do the usual work of such threads.

The tension-cylinder *e* being free to turn, the tension of the thread can be increased or lessened as desired by making the thread to take more or less turns about the same.

It will be observed that the tension-cylinder *e* is attached directly to the pivoted bobbin-frame, instead of being arranged transversely across the shell and journaled in its sides, by which arrangement it is easily reached and operated by swinging out the frame, as shown in Fig. 2.

I claim as my invention—

The tension-cylinder *e*, when constructed as described and combined with the bobbin-frame and bobbin, as set forth—that is, when the tension-cylinder is attached to the bobbin-frame by means of a collar, which forms a bearing for one end of the bobbin.

A. W. JOHNSON.

Witnesses:

E. W. N. STARR,  
H. W. B. STARR.