

D. MURPHY.

Thrashing Machine.

No. 111,766.

Patented Feb. 14, 1871.

Fig. 1

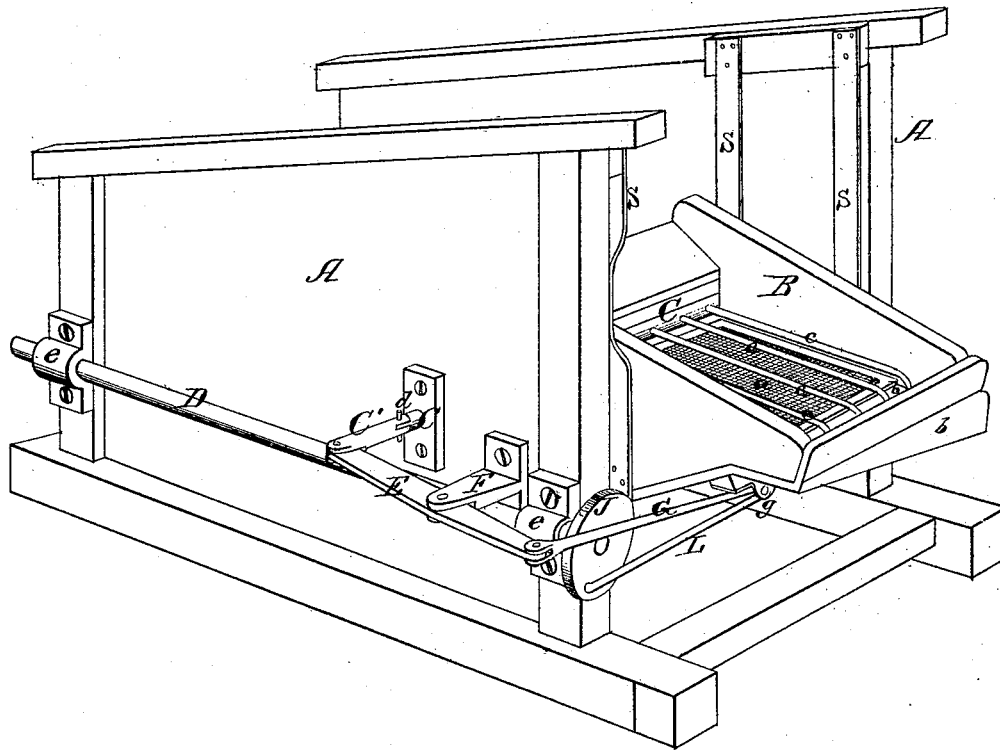
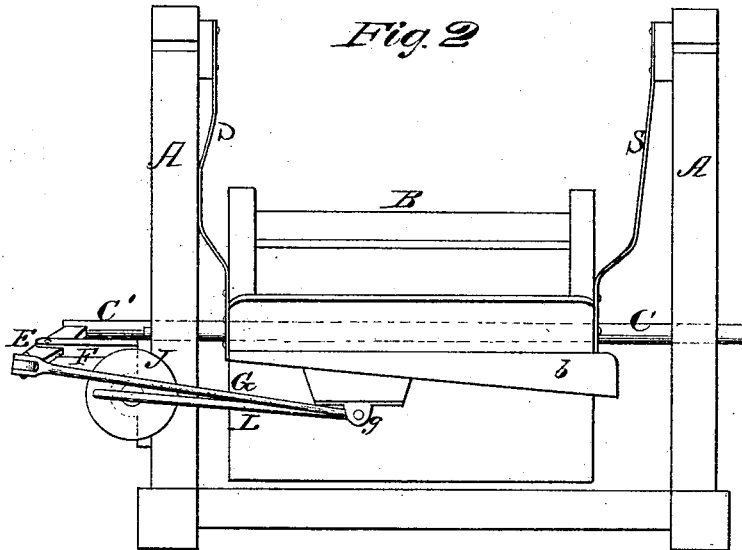

Fig. 2



Inventor.
 Daniel Murphy
 by
 Mason, Fenwick & Lawrence.

Witnesses.
 H. J. Causwell
 J. N. Campbell

D. MURPHY.
Thrashing Machine.

No. 111,766.

Patented Feb. 14, 1871.

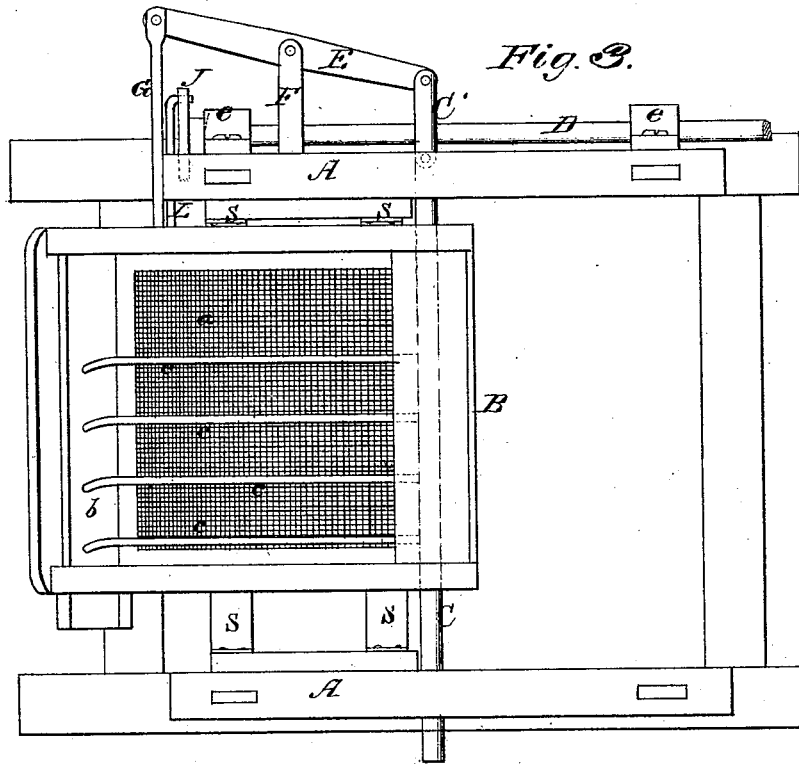

Fig. 3.

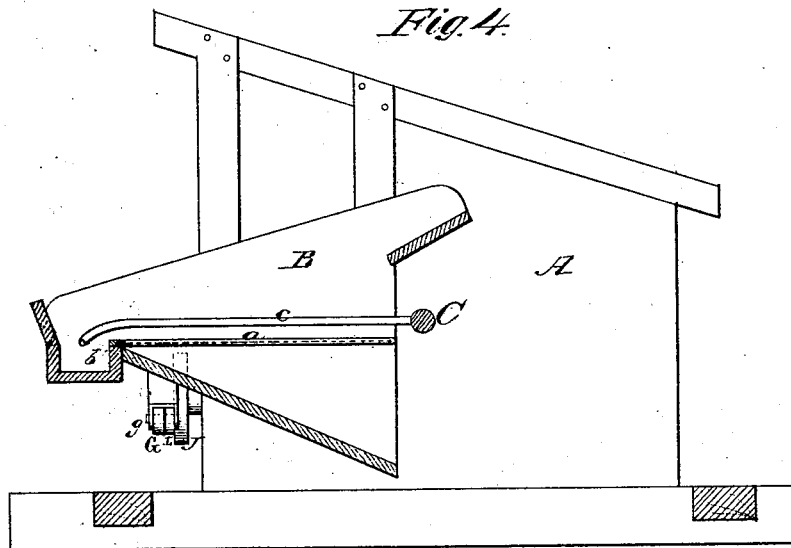

Fig. 4.

Witnesses:
R. J. Campbell.
J. W. Campbell.

Inventor:
Daniel Murphy
by
Mason, Fenwick & Lawrence

United States Patent Office.

DANIEL MURPHY, OF DUBUQUE, IOWA, ASSIGNOR TO HIMSELF AND
TIMOTHY C. MURPHY, OF SAME PLACE.

Letters Patent No. 111,766, dated February 14, 1871.

IMPROVEMENT IN RIDDLES FOR THRASHING-MACHINES.

The Schedule referred to in these Letters Patent and making part of the same

To all whom it may concern:

Be it known that I, DANIEL MURPHY, of Dubuque, in the county of Dubuque and State of Iowa, have invented a new and Improved Clearer for the Riddles of Thrashing-Machines; and I do hereby declare that the following is a full, clear, and exact description thereof, reference being had to the accompanying drawing making part of this specification, in which—

Figure 1, plate 1, is a perspective view of a thrashing-machine frame and riddle having my invention applied to it.

Figure 2, plate 1, is an elevation of one end of the same.

Figure 3, plate 2, is a top view of the same.

Figure 4, plate 2, is a longitudinal section taken vertically and centrally through the same.

Similar letters of reference indicate corresponding parts in the several figures.

The object of this invention is to keep the riddles of thrashing-machines clear by preventing the lodgment thereon of straws, unthrashed heads of grain, sticks, and other foreign substances; also, to stir up wet grain or chaff which may fall on the riddles.

My invention consists in the combination of laterally reciprocating clearing fingers with a laterally movable riddle-shoe; also in communicating the lateral motions to the riddle-shoe and clearers by means which are actuated by a single driving-shaft, as will be hereinafter explained.

The following description will enable others skilled in the art to understand my invention.

In the accompanying drawing—

A A represent the sides of a frame of a thrashing-machine, and

B represents a riddle-shoe, which is suspended within said frame by means of spring-straps S S, two on each side.

The riddle-shoe B being of less width than the frame of the machine, and hung by means of spring-straps, this shoe is allowed to receive a lateral shaking motion.

The screen *a* in the shoe empties its trash into a laterally-inclined spout, *b*, while the grain which passes through the riddle escapes backward, and is received into a suitable receptacle in the usual well-known manner.

At a suitable point on the bottom of the riddle-shoe, ears *g* are secured, to which two pitmen-rods G

L, are pivoted eccentrically to the face of a wheel, J, which is keyed on one end of a longitudinal driving-shaft, D, which has its bearings in boxes *e e*.

The other rod, G, is pivoted to one end of a lever, E, which has its fulcrum on a bracket, F, and which is pivoted at its rear end to a jointed section, C, of a horizontal rod, C.

The rod C extends transversely across the thrashing-machine frame, and has its bearings in the sides thereof.

This rod C receives an endwise motion from the lever E, which lever receives a vibrating motion from the shaft D, through the medium of the eccentric J, pitman-rod L, shoe B, and pitman-rod G.

The rod C has a number of clearing-fingers, *c c c c*, secured at right angles to it, which fingers are preferably made of square rods, although they may be made of round or flat rods.

The rod C is arranged in such relation to the inclined plane of the riddle *a*, that the fingers *c* lie over this riddle in close proximity to it.

From the above description, it will be seen that when the shaft D is rotated, the riddle-shoe and the clearing-fingers will receive alternate laterally-reciprocating movements, and that the fingers *c* will stir up and keep in motion any foreign substances which may fall on the riddle, thereby preventing such substances from attaching themselves to the meshes of the riddle and clogging the same.

It will also be seen that the riddle-shoe, and also the clearing-fingers, receive their motion from a single driving-shaft; also, that these devices are applicable to almost all of the well-known thrashing-machines.

Having described my invention,

What I claim as new, and desire to secure by Letters Patent, is—

1. The combination of the rods G L, shoe B, crank J, and lever E, when said parts are arranged for operation in the manner and for the purpose shown and described.

2. The laterally-sliding fingers *c c*, jointed rod C C', shaft D, lever E, rods G L, crank J, and riddle-shoe B, all constructed and arranged for operation substantially as described.

DANIEL MURPHY.

Witnesses:

JOHN DEERY,
TIMOTHY C. MURPHY.