

(No Model.)

A. WARTH.  
HUB ATTACHING DEVICE.

No. 260,811.

Patented July 11, 1882.

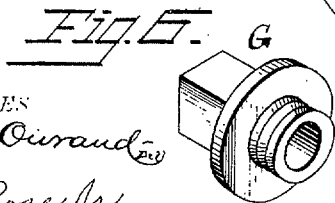
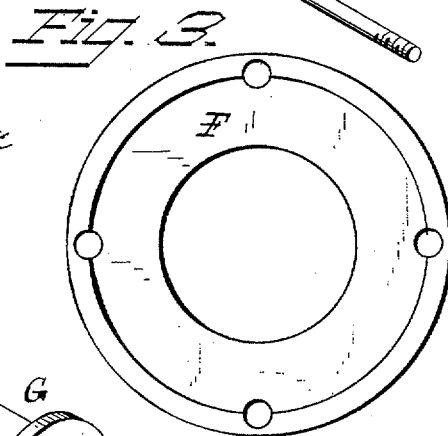
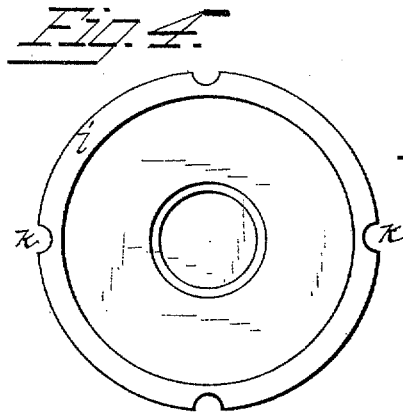
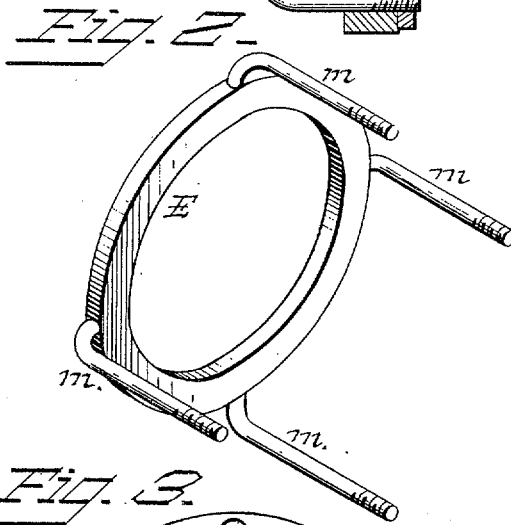
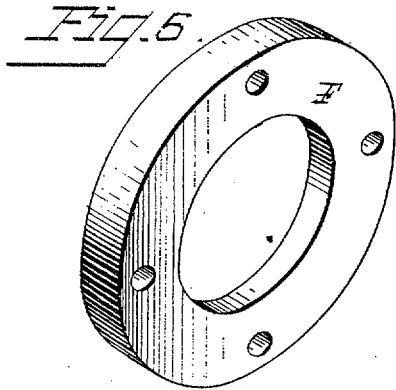
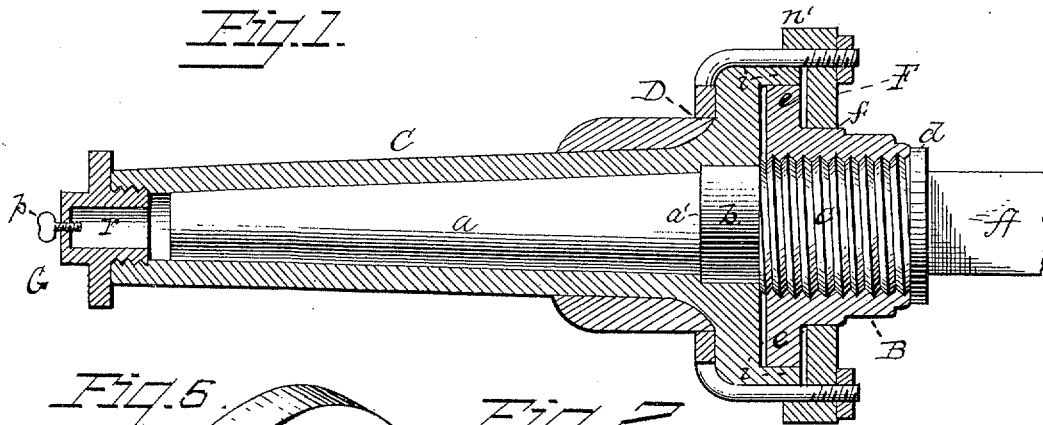

WITNESSES  
Frank L. Ostrand  
Geo. W. Rose, Jr.

INVENTOR  
August Warth.  
by Heylmunt Kaul,  
Attorney.

# UNITED STATES PATENT OFFICE.

AUGUST WARTH, OF GALVESTON, TEXAS.

## HUB-ATTACHING DEVICE.

SPECIFICATION forming part of Letters Patent No. 260,811, dated July 11, 1882.

Application filed April 13, 1882. (No model.)

To all whom it may concern :

Be it known that I, AUGUST WARTH, a citizen of the United States of America, residing at Galveston, in the county of Galveston and State of Texas, have invented certain new and useful Improvements in Hub-Attaching Devices ; and I do hereby declare the following to be a full, clear, and exact description of the invention, such as will enable others skilled in the art to which it appertains to make and use the same.

This invention has relation to hub-attaching devices, and is designed as an improvement on the devices shown and described in Letters Patent of the United States of America granted to me November 22, 1881, No. 249,809.

These improvements are designed to provide better and additional fastening means for securing the axle-box to the spindle.

My improvements consist in a metallic annulus formed or provided with rearward-extending bolts.

My improvements further consist in the combination, with an axle-box formed with an annular shoulder at the base of the fins and a plurality of longitudinal grooves in the perimeter, of a metallic annulus adapted to the shoulder in the axle-box, and formed or provided with a plurality of rearward-extending bolts, for the purposes hereinafter set forth.

My improvements further consist in an axle-box formed with an annular shoulder at the base of the fins and a plurality of grooves in its perimeter, in combination with an annulus adapted to the shoulder in the axle-box, and formed or provided with rearward-extending bolts and nuts fitting in the grooves of the axle-box, and an abutting cap or ring, as hereinafter set forth.

My improvements also consist in the novel construction and combination of parts, as will be hereinafter set forth.

In the accompanying drawings, making a part of this specification, Figure 1 is a longitudinal sectional view. Fig. 2 is a perspective view of the annulus, with bolts and fastening means. Fig. 3 is a view of the cap with flange to fit over the end of the axle-box, and Fig. 4 is an end view of the axle-box. Fig. 5 is a perspective view of cap F, and Fig. 6 is a detached view of end nut.

The letter A represents the end of an axle formed with a tapering spindle, *a*, shoulder *a'*, straight circular bearing *b*, screw-threads *c*, and abutting flange or ring *d*.

The letter B represents the screw-threaded sleeve or collar, corresponding in lateral measurement and in internal diameter to the screw-threaded portion of the spindle over which it is designed to fit. This sleeve or collar is formed with an annular flange, *e*, circular bearing *f*, and wrench-grip space for screwing in place on the spindle or while removing it. The annular flange of this sleeve fits in the open end of the axle-box, and the bearing *f* corresponds with the opening in the ring which is screwed over the face of the box. These parts are herein set out and described as being common with my improved hub-attaching device described in my Letters Patent hereinbefore mentioned.

The letter C represents the axle-box, provided at the outer end with internal screw-threads, and in interior conformation corresponds to the form of the spindle, and the tapering portion made somewhat longer than the tapering portion of the spindle. This axle-box is also formed with an annular shoulder, D, at the base of the fins, and has the wall against which the annulus, hereinafter described, sets at or nearly at right angles to the shoulder, and in the perimeter of the body and annular wall *i* of the axle-box are formed a plurality of semicircular grooves *k* for the purpose of receiving the bolts of the ring or annulus, as hereinafter described.

The letter E represents a metallic ring or annulus, which fits over the shoulder on the axle-box at the base of the fins, and is provided with curved extending bolts *m*, having screw-threads and nuts on the ends, and fits in the semicircular grooves in the box and extends through the bolt-holes in the abutting cap, substantially as seen in Figs. 1 and 3 of the drawings.

The letter F represents the abutting cap or ring, with a central circular opening, *n*, fitting about the bearing *f*, and formed with a horizontal wall, *n'*, adapted to fit over the end of the axle-box, and by means of the bolt-holes through it, which correspond to the bolts of the ring on the spindle, it is secured to the face and over the end of the axle-box, as shown in Fig. 1 of the drawings. Between the inner face

of the ring F and the face of the screw-threaded sleeve and flange of the axle-box a leather washer or rubber ring is fixed, for the purpose of obviating rattling of the parts when in motion. At the outer end of the axle-box, fitting the screw-threads of the same, is the hollow nut or chambered cap G, which does not quite reach the end of spindle, and in the center of this nut is a perforation, with a screw, *p*, inserted. The chamber *r* in this cap is for the purpose of holding the lubricator, and the central perforation with screw therein is intended to afford ready and quick means for introducing and preventing waste of the lubricating material.

To apply my improvements in use the screw-threaded sleeve is put in its place in the open end of the axle-box, the annulus or ring being in place on the shoulder at the base of the fins, with its bolts set in the longitudinal grooves, after which the abutting cap is adjusted on the bolts, the intervening washer having been inserted, and then screwed home and secured by the nuts on the bolts. The wheel is put on over the spindle and the screw-threaded sleeve screwed thereon.

What I claim as my invention, and desire to secure by Letters Patent, is—

1. A metallic ring adapted to be adjusted around a shoulder on the axle-box, formed or provided with a plurality of rearward-extending bolts, substantially as described.
2. An axle-box formed with an annular

shoulder at the rear of the fins and a plurality of longitudinal grooves, in combination with a metallic ring adapted to set around said shoulder, and formed or provided with a plurality of rearward-extending bolts with fastening means, substantially as described.

3. The combination, with an axle-box formed with an annular shoulder at the base of the fins and rearward-extending longitudinal grooves, of a metallic ring provided with a plurality of curved bolts, and an abutting cap fitting over the end of the axle-box and secured against the same, substantially as set forth.

4. The combination, with an axle-box formed with an annular shoulder at the base of the fins and rearward-extending longitudinal grooves, of a metallic ring provided with a plurality of curved bolts, an abutting cap fitting over the end of the axle-box and secured against the same, and a screw-threaded sleeve, substantially as described.

5. The combination, with solid spindle formed substantially as described, of the axle-box C, having the shoulder D and longitudinal grooves *k*, the ring E, having the bolts *m*, the abutting cap F, and screw-threaded sleeve B, substantially as described.

In testimony whereof I affix my signature in presence of two witnesses.

AUGUST WARTH.

Witnesses:

F. GAY,  
JOHN FORD.