

(No Model.)

C. APPLETON.  
STOCKING.

No. 260,922.

Patented July 11, 1882.

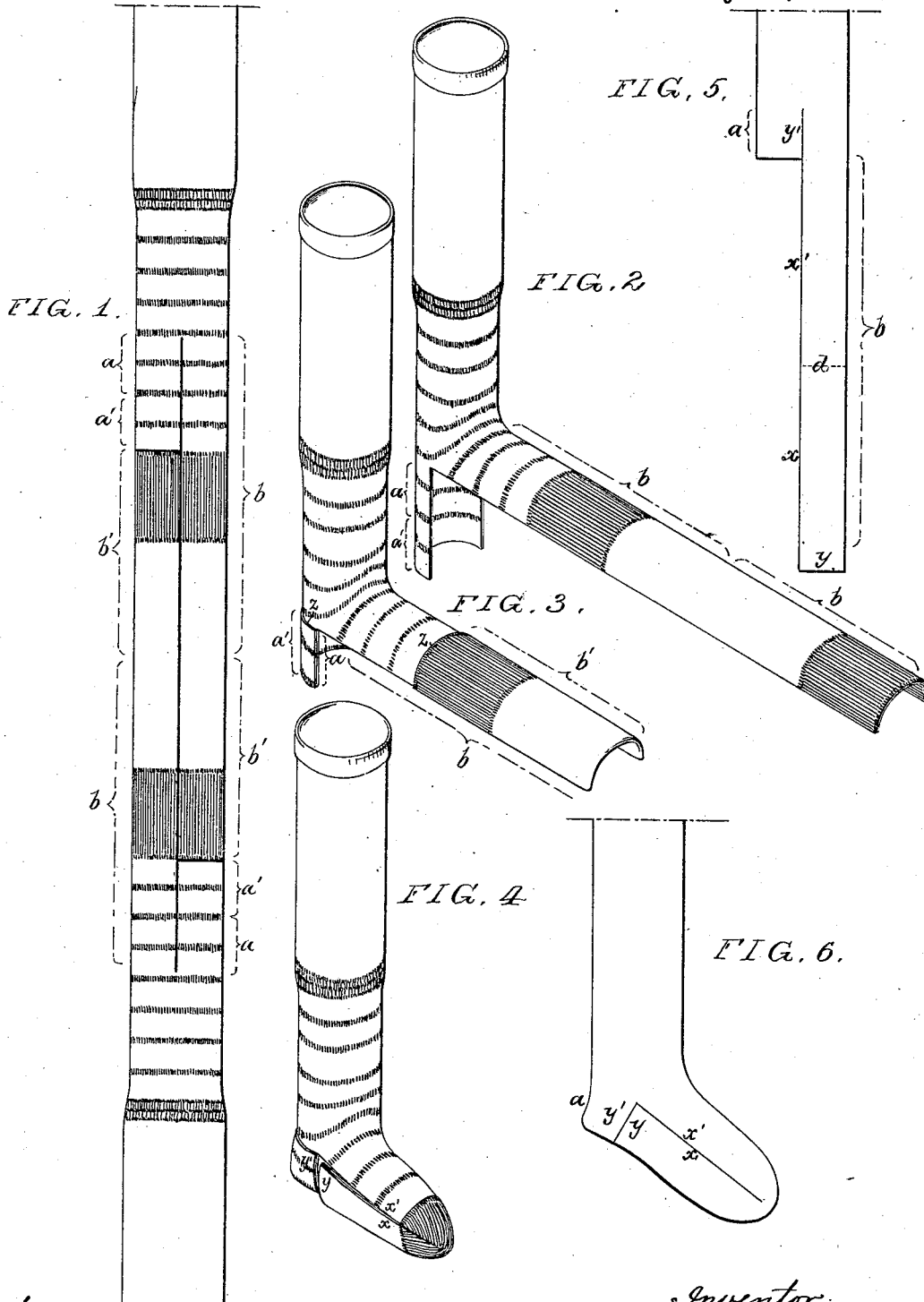

Witnesses:  
James L. Tobin  
Harry Drury

Inventor:  
Celara Appleton.  
By her attorneys  
Flores and Jones

# UNITED STATES PATENT OFFICE.

CLARA APPLETON, OF BRISTOL, PENNSYLVANIA.

## STOCKING.

SPECIFICATION forming part of Letters Patent No. 260,922, dated July 11, 1882.

Application filed February 14, 1882. (No model.)

To all whom it may concern:

Be it known that I, CLARA APPLETON, a citizen of the United States, residing in Bristol, Bucks county, Pennsylvania, have invented an Improvement in the Manufacture of Cut Stockings, of which the following is a specification.

The object of my invention is to so cut stocking-blanks from tubes or webs that there will be a double thickness of fabric at the heel and throughout portions of the foot; and this object I attain in the manner which I will now proceed to describe, reference being had to the accompanying drawings, in which—

Figure 1 is a view of a tubular web of knitted fabric, showing how blanks are cut therefrom for the manufacture of my improved stocking. Figs. 2, 3, and 4 are perspective diagrams illustrating the various stages in the manufacture of stockings from said blanks; Fig. 5, a view of a stocking-blank cut in the usual manner, and Fig. 6 a view of a stocking made therefrom.

In making ordinary stockings from tubes of knitted fabric blanks are cut, as shown in Fig. 5, so as to present a projecting heel portion, *a*, and foot portion *b*, and the latter is then folded on the central line, *d*, the edges *x* united to the edges *x'*, and the edges *y* to the edges *y'*, of the heel-projection *a*. This forms a stocking with a foot and heel having a single thickness of fabric throughout.

The object of my invention is to so cut a tube or web of knitted fabric as to provide double thicknesses of fabric at such parts of the stocking as may be necessary, in order to resist wear or serve as a better protection from the cold.

The mode of carrying out my invention is to cut the tube so that the foot and heel portions of the stocking-blank will be longer than usual. Thus on reference to Figs. 1 and 2 it will be seen that the heel portion *a* has a surplus, *a'*, and the foot portion *b* a surplus, *b'*. These surplus portions are then folded over and secured to the main heel and foot portions at *z*, as shown in Fig. 3, the surplus portion *a'* of the heel entirely overlapping the main portion of the same, and the surplus portion *b'* of the foot overlapping the main portion to the extent shown, so that when the blank is again folded, as shown in Fig. 4, and then seamed at the edges *x x' y y'*, as usual, the heel, sole, and toe of the foot will have a double thickness

of fabric, and the stocking will consequently be warmer and more durable than one made in the usual manner with a single thickness of fabric throughout.

It should be observed here that Figs. 2, 3, and 4 represent the stockings turned inside out, as usual, during the process of manufacture.

My invention is of great advantage in making that class of stockings in which the tube has at intervals bands of a color differing from that of the main portion of the tube, so as to make a stocking with a toe differing in color from the rest of the foot. To produce such a stocking the tube has to be made as shown in Fig. 1, the wide shaded bands representing the toe portions, and in cutting ordinary stocking-blanks from such a tube great waste of fabric results—a waste which is entirely overcome by my invention.

Although I have described my invention in connection with tubes of knitted fabric, it can be applied to the cutting of stocking-blanks from single flat webs of fabric.

I have described my invention as applied to stockings; but it will be evident that this term includes socks as well.

I claim as my invention—

1. A cut stocking in which the foot portion *b* is combined with a supplementary strip, *b'*, united to the foot at the edge *z*, adapted to form a lining for the toe and sole, and united to the heel of the stocking with said sole, all substantially as specified.

2. The mode herein described of forming a double heel on a cut stocking, said mode consisting in cutting the heel *a* with a surplus portion, *a'*, folding said surplus portion up onto the heel, and uniting it thereto at the upper edge, *z*, as set forth.

3. The mode herein described of forming a double toe and sole on a cut stocking, said mode consisting in cutting the foot *b* with a surplus portion, *b'*, adapted to form said toe and sole, folding said surplus portion over the foot, and uniting its edge *z* thereto, as set forth.

In testimony whereof I have signed my name to this specification in the presence of two subscribing witnesses.

CLARA APPLETON.

Witnesses:

SALLIE PEARSON,  
KATE R. WILSON.