

(No Model.)

H. A. LUGRIN.

STOP WATCH.

No. 302,749.

Patented July 29, 1884.

Fig. 1.

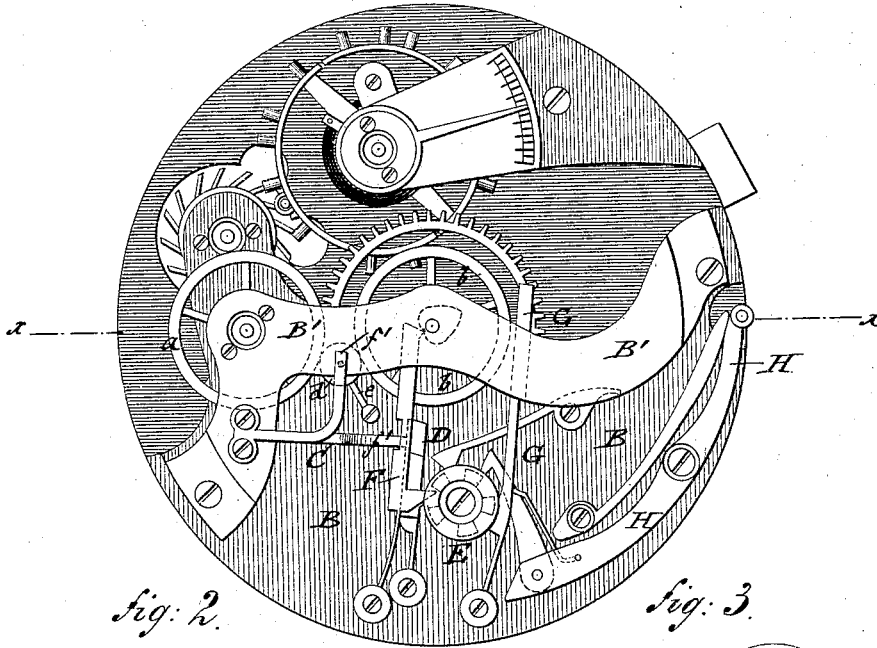

Fig. 2.

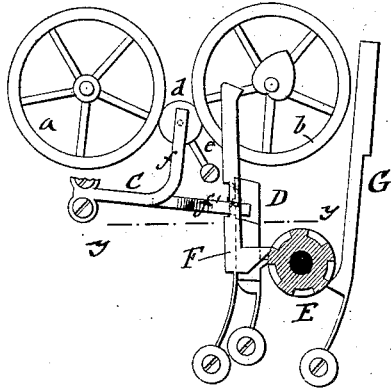

Fig. 3.

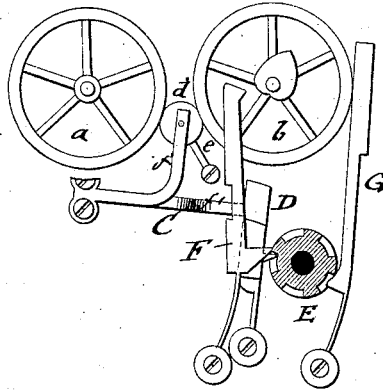
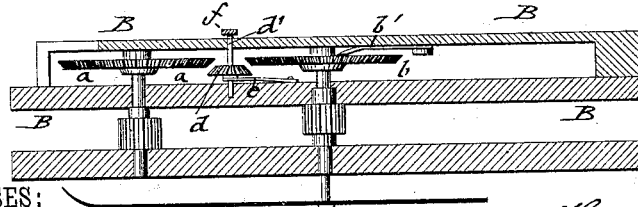
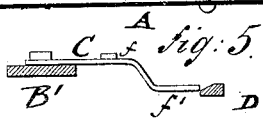

Fig. 4.



WITNESSES:
A. Schehl.
Martin Petry.



INVENTOR
Henry A. Lugin
 BY *J. J. ...*
 ATTORNEYS.

UNITED STATES PATENT OFFICE.

HENRY A. LUGRIN, OF NEW YORK, N. Y., ASSIGNOR TO HIMSELF AND
PROSPER NORDMANN, OF SAME PLACE.

STOP-WATCH.

SPECIFICATION forming part of Letters Patent No. 302,749, dated July 29, 1884.

Application filed November 26, 1883. (No model.)

To all whom it may concern:

Be it known that I, HENRY A. LUGRIN, of the city, county, and State of New York, have invented certain new and useful Improvements in Stop-Watches, of which the following is a specification.

This invention has reference to certain improvements in stop-watches for which Letters Patent have been granted to me heretofore, No. 232,737, dated September 28, 1880, whereby the mechanism for operating the quarter-second hand is set in motion from the arbor of the fourth wheel of the watch-movement by an intermediate mechanism, which is quickly thrown in or out of gear, so as to produce the instant and reliable starting or stopping of the quarter-second hand; and the invention consists of a vertically-movable bevel-pinion that is thrown into gear with a bevel-wheel on the arbor of the fourth wheel and a bevel-wheel on the arbor of the quarter-second hand, said bevel-pinion being raised or lowered by a forked spring and actuating-lever, so as to start or stop the quarter-second hand.

The invention consists, secondly, of the combination, with the arbor of the bevel-pinion, of a forked spring, one arm of which presses on the arbor of the bevel-pinion, a lever for engaging the other end of said spring, a spring that exerts a lifting action on the bevel-pinion, a bevel-wheel on the arbor of the fourth wheel and on the arbor of the second-hand, and a spring of less power than the spring of the bevel-pinion that presses upon the bevel-wheel on the arbor of the quarter-second hand, so as to produce the reliable intermeshing of the bevel-pinion and the bevel-wheels whenever the former is thrown into mesh therewith, as will be more fully described hereinafter, and finally be pointed out in the claims.

In the accompanying drawings, Figure 1 represents a top view of my improved stop-watch, in which the different operating parts are shown in their respective positions when the quarter-second hand is at zero. Figs. 2 and 3 are detail top views showing the operating parts of the stop-watch, respectively, in position when the quarter-second hand is started and stopped. Fig. 4 is a vertical trans-

verse section on line *x x*, Fig. 1; and Fig. 5 is a detail side view, partly in section, on line *y y*, Fig. 2, of the forked spring for throwing the bevel-pinion in or out of gear with the motion-transmitting bevel-wheels.

Similar letters of reference indicate corresponding parts.

My improved timing attachment for stop-watches is set in motion by the arbor of the fourth wheel of the watch-movement, which arbor carries a minutely-toothed bevel-wheel, *a*. The arbor of the quarter-second hand *A* is also provided with a minutely-toothed bevel-wheel, *b*, on which presses a spring, *b'*.

Intermediately between the bevel-wheels *a* and *b* is arranged a finely-toothed bevel-pinion, *d*, the arbor *d'* of which is supported in bearings of the main bridge *B* of the watch-movement, and of an auxiliary bridge, *B'*, that supports the different arbors of the timing attachment. The bevel-pinion *d* is acted upon at its under side by a spring, *e*, of a greater strength than the spring *b'* of the bevel-wheel *b*, the spring *e* tending to lift the bevel-pinion *d* whenever one end, *f*, of a forked spring, *C*, that presses on the arbor of the bevel-pinion is raised. The forked spring *C* is attached to the auxiliary bridge *B'*, its second arm, *f'*, being bent downward toward the main bridge *B*, and engaged or released by a spring-lever, *D*. The lever *D* is operated by a double ratchet-wheel, *E*, which also operates the shifting-lever *F* and the brake-lever *G*, that is placed in or out of contact with the circumference of the bevel-wheel of the quarter-second hand. The starting and stopping lever *H* is operated in the usual manner by a push-pin from the outside of the watch-case. The shifting-lever *F* engages a heart-cam on the arbor of the bevel-wheel *b*, which, together with the double ratchet-wheel, shifting-lever, brake-lever, and starting-lever, form the well-known accessories of the stop-watches in general use, and which require no special description.

The operation of my improved stop-watch is as follows: For starting the quarter-second hand, the lever *H* is oscillated by the push-pin and the double ratchet-wheel *G* moved,

whereby the shifting and brake levers are respectively moved away from the heart-cam and the bevel-wheel on the arbor of the quarter-second hand. Simultaneously the lever D is moved by the double ratchet-wheel G, so that its beveled outer end passes below the lower arm, f' , of the forked spring C, whereby the arm f' is raised, and thereby the bevel-pinion d instantly lifted by its spring e and thrown into gear with the bevel-wheels a and b , the teeth of which are parallel to the teeth of the bevel-pinion. To prevent the jarring by the too sudden intermeshing of the teeth of the bevel-pinion d with the bevel-wheel b of the quarter-second hand, a small degree of play is given to the arbor of the latter, which play, however, is compensated by the pressure of the spring b' on the bevel-wheel b . As this spring, however, is of about half the force of the spring e acting on the bevel-pinion, it recedes slightly and admits thereby the quick and reliable intermeshing without exerting any jar or concussion, and consequently without producing any vibratory effect or lost motion on the quarter-second hand. The quarter-second hand is therefore instantly started, and moved forward until stopped by the second depression of the stop-lever H, which applies, by the double ratchet-wheel, the brake-lever G to the circumference of the bevel-wheel b , while the lever D recedes from the lower arm, f' , of the spring C, as shown in Fig. 3, and causes, by the pressure of the upper arm, f , of the spring C upon the arbor of the bevel-pinion d , the lowering of the bevel-pinion against the pressure of its spring e , so that the bevel-pinion is thrown out of gear with the bevel-wheels a and b , and thereby the quarter-second hand stopped. The shifting-lever F is held at a proper distance from the heart-cam, as shown in Fig. 3. A third depression of the stopping-lever H applies the shifting-lever to the heart-cam, and moves the brake-lever away from the bevel-wheel b , as shown in Fig. 1, whereby the quarter-second hand is returned to the starting-point. The lever D, that raises the arm f' of the forked spring C, remains in

the same position as in Fig. 3, with the bevel-pinion in lowered position. In this manner the different operations of starting, stopping, and returning the quarter-second hand are accomplished in a reliable manner, and motion transmitted to the quarter-second hand at the proper time by the raising or lowering of the intermediate bevel-pinion, while in the stop-watches heretofore in use, either the bevel-wheel on the arbor of the fourth wheel or the bevel-wheel on the arbor of the quarter-second hand was thrown in or out of mesh with the intermediate bevel-pinion.

Having thus described my invention, I claim as new and desire to secure by Letters Patent—

1. As an improvement in stop-watches, the combination of a toothed bevel-wheel on the arbor of the fourth wheel, a toothed bevel-wheel on the arbor of the quarter-second hand, an intermediate bevel-pinion, a lifting-spring applied to the same, a forked spring pressing by one arm on the arbor of the bevel-pinion, and an actuating-lever that engages or releases the second arm of the forked spring, so as to throw the bevel-pinion in or out of gear with the bevel-wheels, substantially as set forth.

2. As an improvement in stop-watches, the combination of a toothed bevel-wheel on the arbor of the fourth wheel, a toothed bevel-wheel on the arbor of the quarter-second hand, a recoil-spring pressing on the bevel-wheel of the quarter-second hand, an intermediate bevel-pinion, a lifting-spring of greater strength than the recoil-spring, a forked spring bearing by one arm on the arbor of the bevel-pinion, and an actuating-lever that engages or releases the second arm of the spring, substantially as and for the purpose set forth.

In testimony that I claim the foregoing as my invention I have signed my name in presence of two subscribing witnesses.

HENRY A. LUGRIN.

Witnesses:

PAUL GOEPEL,
SIDNEY MANN.