

(No Model.)

J. T. SCHAFFER.
CONTINUOUS DRAW BAR AND BUFFER.

No. 303,951.

Patented Aug. 19, 1884.

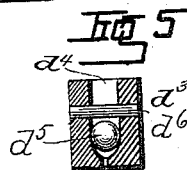
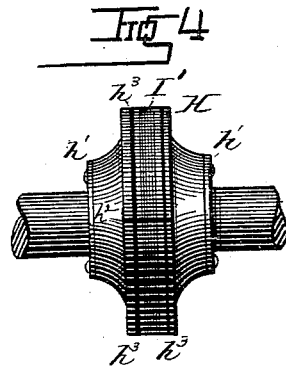
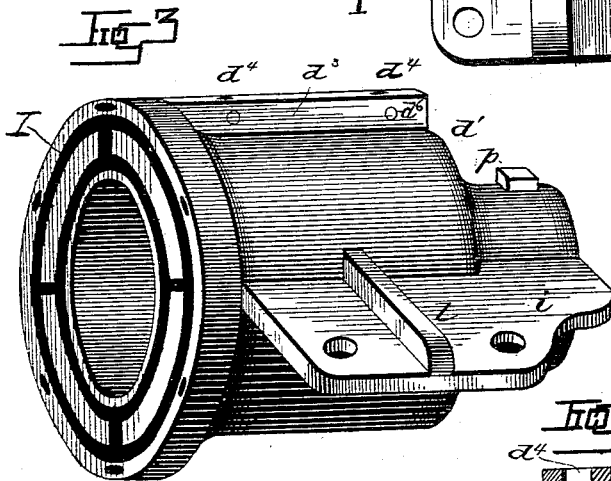
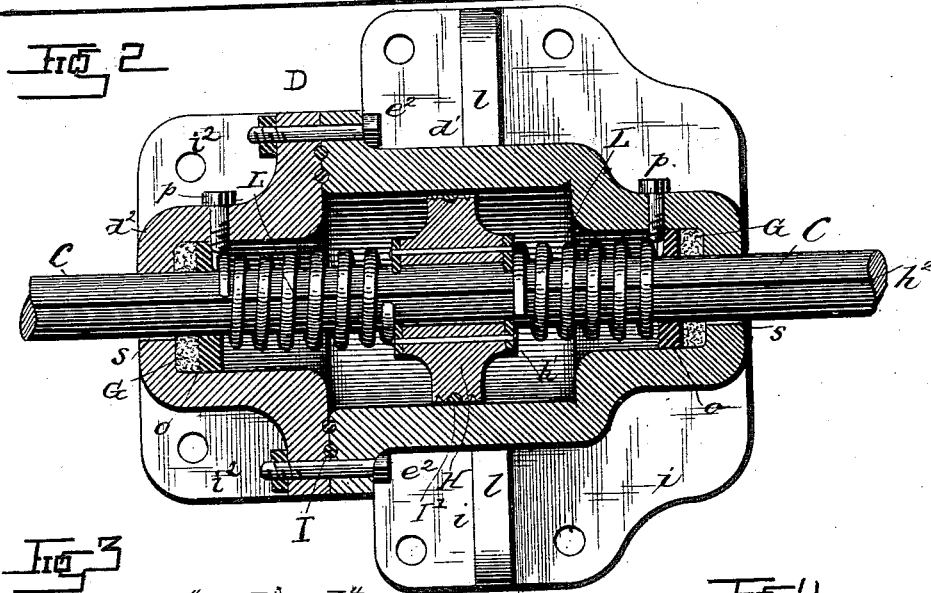
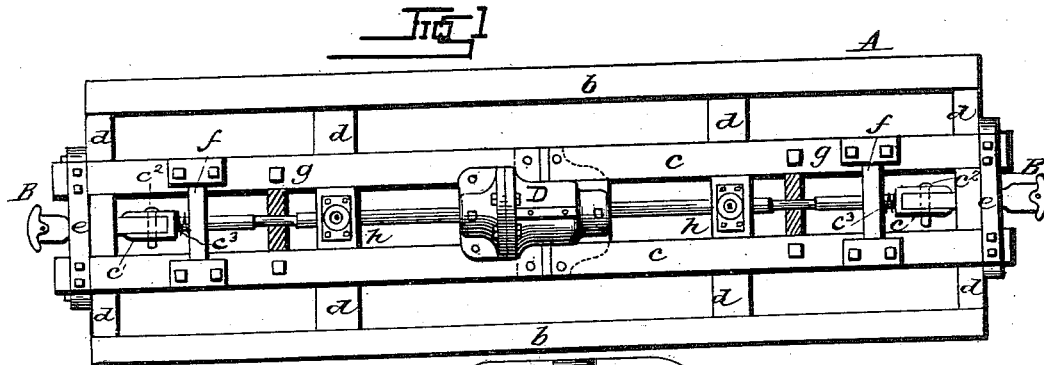

WITNESSES:

Wm. S. Dietrich
John G. Fink

INVENTOR.

John T. Schaffer
by *Wm. H. Woodcock*
ATTORNEY

UNITED STATES PATENT OFFICE.

JOHN T. SCHAFFER, OF ROCHESTER, NEW YORK, ASSIGNOR OF TWO-THIRDS
TO JONAS JONES, OF SAME PLACE.

CONTINUOUS DRAW-BAR AND BUFFER.

SPECIFICATION forming part of Letters Patent No. 303,951, dated August 19, 1884.

Application filed August 2, 1883. (No model.)

To all whom it may concern:

Be it known that I, JOHN T. SCHAFFER, a citizen of the United States, residing at Rochester, in the county of Monroe and State of New York, have invented certain new and useful Improvements in a Continuous Draw-Bar and Buffer; and I do hereby declare the following to be a full, clear, and exact description of the invention, such as will enable others skilled in the art to which it appertains to make and use the same.

The object of my invention is the adaptation to a railway continuous draw-bar of a cylinder-buffer; and it consists, as to the buffer, in a modification of the form patented to me May 29, 1883, Patent No. 278,606, and, as to the remaining parts, in certain changes in the draw-bar and in the frame-work of a car, by which the bar is made continuous and the buffer adapted to the same, as more fully hereinafter described.

My invention is illustrated in the accompanying drawings, in which Figure 1 is an inverted plan view of car-frame with buffer applied thereto; Fig. 2, a sectional top view of cylinder and attachments; Fig. 3, a detached view of part of cylinder with cap removed; Fig. 4, a detached sectional view of piston, and Fig. 5 a detached view of air passage and valve in the cylinder.

In the drawings, A is a frame composed of outer sills, *b b*, and center sills, *c c*, connected by the cross-pieces *d*. The center sills are also joined at their ends by straps *e e*, which support the draw-head B in the usual manner. These sills are also connected by straps and blocks *f f*, *g g*, and *h h*, which form bearings for the draw-bar.

C is the draw-bar, connected at each end to the draw-head, each end of the draw-bar being passed through a yoke, *c'*, and attached to the arm of the draw-head by bolt *c''*. The yoke *c'* is slotted to permit the draw-bar to slide therein. A spiral spring, *e'*, surrounds each end of the draw-bar back of the yoke *c'*, and next to the strap *f*, which springs answer the usual purpose of additional cushions for the draw-heads at those points. The draw-bar is cut out at the bearings *g g* to permit of its endwise movement.

D is a cylinder composed of two pieces, *d'* and *d''*, the former part being called, for convenience, the "body," and the latter mentioned part the "cap," which parts are bolted together by screw-bolts *e''*. The body *d'* is provided with flanges *i i* and ribs *l*, and the cap *d''* with flanges *i'' i''*, and these flanges are bolted to the sills, as shown in Fig. 1, the center sills being mortised to receive the ribs *l*. The body is also provided with a flange or rib, *d''*, through which extend passages *d'* into the cylinder for the egress of air alternately from the sides of the piston, as hereinafter explained. In these passages, as shown in Fig. 5, which are contracted to a very narrow slit, are placed valves *d''*, which close the passages, except when air is forced out by the action of the piston. The ball-valves shown are held in place by screw-bolts *d'''*.

The draw-bar C extends through the cylinder, and, as shown in Fig. 2, carries a piston-head, H, which is shrunk onto a cut-out portion of the bar, and there is immovably fixed by the divided plates *h'*. The piston-head is held normally at the center of the cylinder by the springs L. On each side of the piston-head the bar is provided with spiral springs L L, and it is also provided with a shallow crease, *h''*, extending from beyond the cylinder through the same and through the piston-head, for the ingress and egress of air to both sides of the piston. The draw-bar passes into the cylinder through stuffing-boxes G, the filling in said boxes being confined and held in place by ring-plates *o*, encircling the bar, and held in place by screw-bolts *p*, and against which plates the springs L abut. The piston-head H is provided with two outer plates, *h'*, a longitudinal groove, *h''*, and circumferential grooves *h'''*, the groove *h''* being for the passage of air from one side of the piston-head to the opposite side, and the grooves *h'''* for the admission of oil to lubricate the cylinder.

I is a rubber gasket composed of two rubber rings connected by cross-pieces of rubber, and placed between the body and cap of the cylinder to form a tight air-joint at that point. The piston H is provided with a similar packing, I'. The body and cap of the cylinder

may also be provided with small creases *s s*, for the admission and escape of air from the opposite sides of the piston.

In operation, on receiving a push the piston-head is forced back against the spring L and the cushion of air, and at the same time air is forced out of one of the passages *d*¹ and the groove *h*² in the draw-bar and the passage *s*. The admission of air into the cylinder and on the opposite side of the piston-head is had at this time only through the openings *h*² and *s*, the other passage *d*¹ being closed by the valve *d*³. In pushing or in pulling the draw-bar, more air is thus forced out through the passages on one side of the piston-head than is received into the cylinder from the opposite side, and thus a partial vacuum is produced within the cylinder, which increases the cushioning effect of the compressed air upon the piston. The operation of the device is the same both in pulling and pushing.

The number and form of several of the features above described may be varied without departing from my invention. For instance, the flanges by which the cylinder is connected to the frame may be changed in shape, the number of air-passages increased or diminished, or some of them dispensed with altogether, the continuous draw-bar may be made in two parts, another form of valve than the ball-valve shown may be employed to close the passage *d*¹, and more than one cylinder may be placed on the draw-bar.

This invention is applicable to street-cars, ships, steamboats, wharves, and other structures, and wherever shock is to be resisted or overcome by the colliding or sudden starting of large and heavy objects.

Having thus described my invention, what I claim is—

1. In a pneumatic buffer, the combination of the cylinder provided with air-passages and springs, with a piston and continuous draw-bar, substantially as described.
2. The combination, with a continuous draw-bar, of the cylinder provided with air-passages, the valves, and a piston, arranged and

operated substantially as described, whereby a partial vacuum is produced within the cylinder.

3. The combination of the continuous draw-bar provided with an air-passage extending through the cylinder, the cylinder provided with outer air-passages, and the piston provided with a passage for the admission of air from one side of said piston to the opposite side, substantially as described.

4. The combination of the frame A, the continuous draw-bar C, the cylinder D, the piston H, and the springs L, substantially as described.

5. The cylinder, in combination with the piston provided with the gasket I' and the plates *h*', and the continuous draw-bar, substantially as described.

6. The cylinder provided with the air-passages *d*¹, and a valve placed in such passages, combined with a suitable draw-bar and piston, substantially as described.

7. The cylinder provided with stuffing-boxes G G at each end, the ring-plates *o o*, and the pins *p p*, in combination with the continuous draw-bar, substantially as set forth.

8. In combination with the body and cap of the cylinder, a gasket composed of two rings connected by cross-pieces, substantially as set forth.

9. The combination of the cylinder, the continuous draw-bar, and the piston provided with the peripheral oil-grooves *h*³ *h*³, and with the gasket I', substantially as set forth.

10. In a pneumatic buffer, the draw-bar C, provided with an air-passage, *h*², substantially as and for the purpose described.

11. In a car-buffer, the combination of the cylinder provided with air-passages *d*¹, the valves *d*³, and the retaining-pins *d*⁶, substantially as set forth.

In testimony whereof I affix my signature in presence of two witnesses.

JOHN T. SCHAFFER.

Witnesses:

GEO. M. LOCKWOOD,
W. E. CHAFFEE.