

J. DUBOC.

SELF ACTING APPARATUS FOR PREVENTING RAILWAY ACCIDENTS.

No. 343,988.

Patented June 22, 1886.

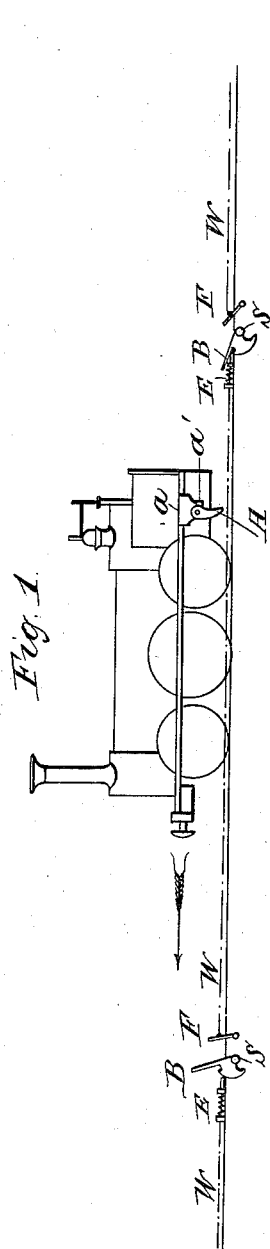
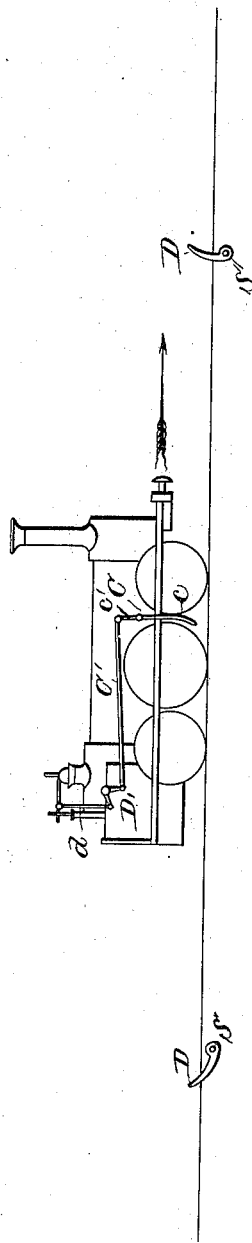

Fig. 1

Fig. 2



Witnesses
M. Kniblock
J. E. Dutton

Inventor
Jules Duboc
per Henry O'Neil
 his atty

J. DUBOC.

SELF ACTING APPARATUS FOR PREVENTING RAILWAY ACCIDENTS.

No. 343,988.

Patented June 22, 1886.

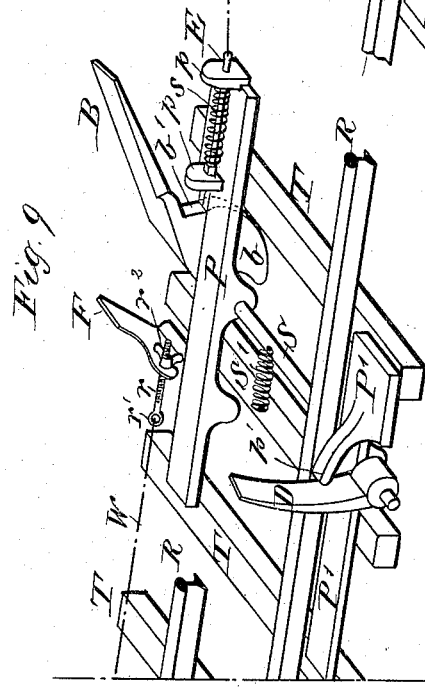
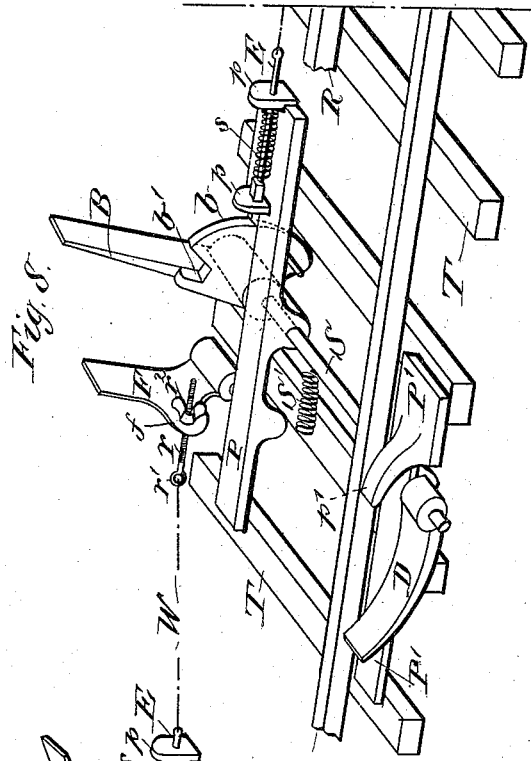
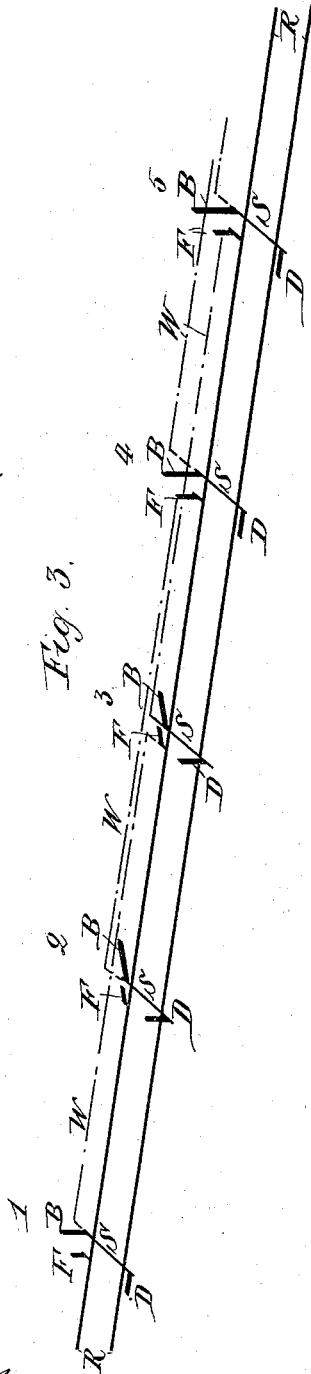

Witnesses
 M. Knobloch
 O. E. Buer

Inventor
 Jules Duboc
 by Henry O'Neil
 his atty.

J. DUBOC.

SELF ACTING APPARATUS FOR PREVENTING RAILWAY ACCIDENTS.

No. 343,988.

Patented June 22, 1886.

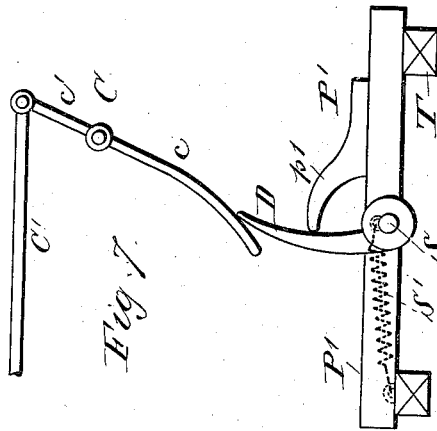
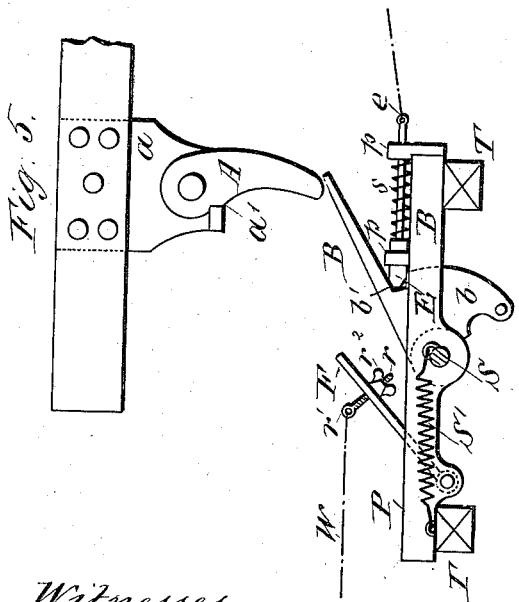
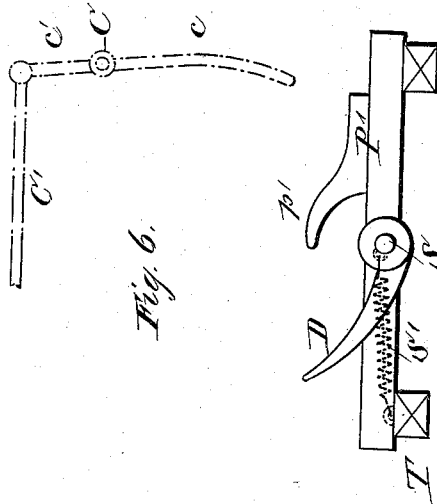
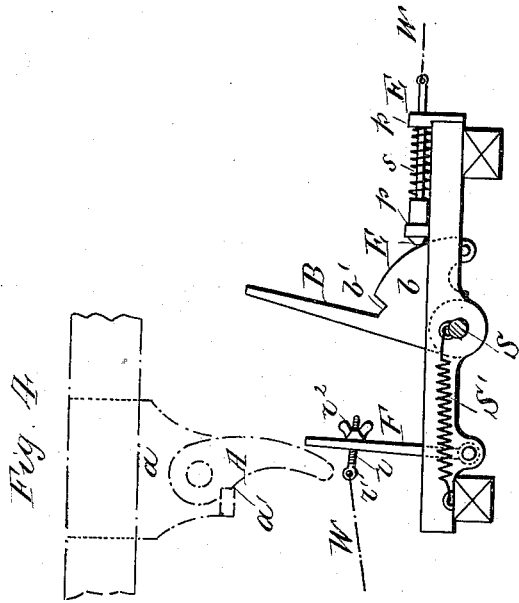

Witnesses
 O. M. Knobloch
 W. E. Gutter

Inventor
 Jules Duboc
 by Henry M. Gutter

UNITED STATES PATENT OFFICE.

JULES DUBOC, OF LISIEUX, CALVADOS, FRANCE.

SELF-ACTING APPARATUS FOR PREVENTING RAILWAY ACCIDENTS.

SPECIFICATION forming part of Letters Patent No. 343,988, dated June 22, 1886.

Application filed April 9, 1885. Serial No. 161,751. (No model.) Patented in France September 8, 1884, No. 164,120, and in England February 17, 1885, No. 2,201.

To all whom it may concern:

Be it known that I, JULES DUBOC, a citizen of the French Republic, residing at Lisieux, in the Department of Calvados, France, have
5 invented certain new and useful Improvements in Devices for Preventing Accidents on Railways, (for which I have obtained Letters Patent in France, No. 164,120, dated September 8, 1884, and in England, No. 2,201, dated
10 February 17, 1885,) of which the following is a full, clear, and exact description.

This invention relates to that class of safety devices for railroads designed to operate a signal and give warning to the engineer of
15 danger ahead, the road being laid out in sections or blocks at greater or less distances from one another, according to the nature of the ground in which these devices are arranged.

The object of this invention is to provide a single and effective mechanism whereby the engineer on his locomotive may be warned in ample time of danger ahead to enable him to stop his train, and thereby avoid a collision
25 with another train ahead of him that has from any cause been delayed or disabled.

The further object of this invention is to so construct and arrange the safety devices as to be automatically set by a passing locomotive
30 to indicate to the engineer of a train in rear that the road is clear, or to give him warning that a train is in dangerous proximity in front of him.

To these ends the invention consists in mechanism and combinations of mechanisms located on the track and operated from the locomotive, and operating, when set at "danger,"
35 to give warning, by an audible or visible signal, to the engineer that a train is close in front of him, substantially as hereinafter fully described, and as specifically pointed out in the claims.

In the accompanying drawings, forming a part of this specification, Figures 1 and 2 are
45 schematic views, the former showing the left side of a locomotive and the corresponding mechanism of the safety devices set at "safety," and in the latter view the right side of the locomotive and the corresponding mechanism of the safety devices set at "danger."
50 Fig. 3 is a like view showing the connections

of several sets of safety devices. Fig. 4 is a sectional side elevation showing the left-hand mechanism of the safety devices in position to be operated by the locomotive to set the
55 devices previously passed at "danger." Fig. 5 is a similar view showing the devices after being actuated. Fig. 6 shows by a like sectional elevation the right-hand devices set at "safety." Fig. 7 shows by a like view the
60 same devices set at "danger" and about to operate a signaling device on the locomotive; and Figs. 8 and 9 are perspective views of two sets of safety devices set at "safety" and
65 "danger," respectively.

In these drawings like letters indicate like parts wherever such may occur.

The safety appliances are arranged along the road at suitable distances from each other, the distance between them depending in a
70 measure on the appliances under the control of the engineer or train-hand, or both, to stop the train within a given distance when running at its greatest speed.

On the left side, and near the engineer's cab
75 or rear end of the locomotive, is pivoted a dog or pawl, A, on a suitable bracket, a, in such a manner that said dog or pawl is free to swing forward on its pivot, but prevented from swinging backward from a vertical line
80 by a shoulder or stop, a', projecting from said bracket a, as shown in Figs. 1, 5, and in dotted lines in Fig. 4. On the right side of the locomotive, and on a line some distance in front of the line where the dog A is pivoted,
85 is fulcrumed a lever, C, the long arm c of which is curved.

To the short arm c' of lever C is pivoted a connecting-rod, C', that is connected through a bell-crank lever, D', and a connecting-rod,
90 d, with the stem of the valve that admits steam to the whistle, as shown in Fig. 2, the lever C operating said valve and surrounding the whistle when said lever is rotated on its fulcrum by a dog or pawl of the safety devices
95 when set at "danger."

It is obvious that instead of connecting the lever C to the whistle-valve it may be connected with the bell-cord or with a rod connected with the bell, or said lever may through
100 its connections be made to operate a visible signal, such arrangements being readily under-

stood by skillful mechanics and within the province of such, and need, therefore, not be shown or described in detail.

Before describing the safety mechanism, I will mention here that the dog or pawl A operates to set the said mechanism to "danger," and that the lever C is operated by the said mechanism when set at "danger" to warn the engineer.

Inasmuch as all the safety devices are alike in construction and operation, it will be necessary to describe one set only, in order that the construction and operation thereof may be understood.

Referring more particularly to Figs. 8 or 9, P and P' indicate two bed or supporting plates provided with bearings for a cross-shaft, S, free to rotate in said bearings. These plates are secured to the ties T, outside the rails R, and on each end of the shaft S are secured on different radial lines arms B and D, respectively. The relative arrangement of the arms B D is such that when arm B is in a vertical position arm D will be in an approximately horizontal position, and vice versa, as shown in Figs. 8 and 9. From the bed-plate P' projects a stop, p', that limits the movement of the arm or cam D toward the right.

The arm B at its pivotal point has the form of a sector, as shown at b, in which is formed a notch or recess, b', with which engages a locking-dog, E. The locking-dog E slides in bearings p p on the supporting-plate P, a spring, s, exerting its power to keep the dog in engagement with said notch b', and S' is a spring secured to one of the ties T at one end and at the other to the shaft S, said spring exerting its power to return the arms B D into their normal position, Fig. 8, after being depressed into the position shown in Fig. 9, when released by the locking-dog E. To the plate P is also secured a pivot pin or stud, on which is pivoted a third arm, F, in advance of the arm B, and on the same side of the track, and said arm is connected, as hereinafter described, to the locking bolt or dog of one of a set of safety devices in the rear. The pivoted pawl or dog A on one side of the locomotive projects into the path of the arms B F, and the lever C, fulcrumed in advance of the dog A on the opposite side of the locomotive, projects into the path of the arm D.

The operation of these devices and their connections with each other may be briefly described to be as follows: Referring to Fig. 3, it will be seen that the locking-dog E of the safety devices marked 1, which we will suppose to be the first from a station—the train being supposed to run from left to right—is connected to the arm F of the second succeeding safety devices—that is to say, to the devices marked 3, the devices marked 2 being connected to those marked 4, and so on, so that there are always two safety devices set at "danger" intervening between one set at "safety" and the one about to be met by the train, the latter being supposed to be running

in section 3 in said Fig. 3. The connection of the locking-dogs E with their respective operating-arms F is effected by means of a wire, W, or other suitable connection, secured at one end to a hook or eye, e, on the shank of the locking-dog E, and at the other to a hook or eye, r', of a screw-rod, r, that passes through a perforation in an ear, f, formed on the arm F, and secured thereto by means of a thumb-screw, r². By means of the described arrangement of the connections between the locking-dogs and arms any slack therein may be readily taken up by manipulating the thumb screw r². As the locomotive enters the section 1, the safety devices of which are in their normal position, (see, also, Fig. 4,) the pivoted dog A on the left of the locomotive will first depress the arm F, which in the first section from a station may be dispensed with, and then the arm B, thereby rotating the shaft S against the stress of its spring S', and simultaneously therewith elevating the arm D into the "danger" position. As the arm B reaches the limit of its downward movement, the locking bolt or dog E, which is held in contact with the face of the sector-shaped portion b of said arm, under the stress of its spring, will move into the notch b' of said arm and lock the parts into position of "danger." (See, also, Figs. 5, 7, and 9.) The same will take place when the locomotive passes the safety device of section 2, setting the arm D thereof at "danger" also. When, however, the locomotive reaches the safety devices of section 3, and the arm F is depressed, the locking-dog E will be drawn out of the notch b' and release the arm B of the safety devices of section 1, and, under the stress of the spring S', the shaft S will be rotated backward to bring the parts into their normal position, as shown in section 1 and in Figs. 8 and 9, showing the parts set at "danger." When the locomotive reaches the next safety devices, or those of section 4, the safety devices of section 2 will be released and returned into their normal position, &c. Should a train be delayed in any one of the sections from any cause, the engineer of the train following would be warned in ample time to stop his train, as the lever C on the right of the locomotive will then encounter the arm D, set at "danger," and the whistle or other danger signal given as above described.

In Fig. 1 I have shown the arms B F on one side of a track, one set of them being depressed and a locomotive detained in the section, and in Fig. 2 I have shown on the other side of the track one of the arms D at "safety" and the other at "danger" and a locomotive about to reach the arm D, set to "danger."

Having described my invention, what I claim, and desire to secure by Letters Patent, is—

1. In a safety mechanism for railways, the combination, with the track, a pivoted shaft extending across the same, and having arms B D, arranged at an angle to each other, the arm A, pivoted upon one side of the locomotive, the

extent of movement of said arm in one direction being limited by a suitable stop or shoulder, said arm operating to reverse or tilt the shaft, a locking device operating to engage the arm B, when the shaft is tilted, and lock the same and its arms in the reversed position, and levers arranged upon the opposite side of the locomotive, connecting with a signaling device, one of the levers being adapted to strike the arm D while in its reversed position, of the pivoted arm F, located at a distance, connected with the locking device, and adapted to be struck by arm A on the locomotive, to withdraw the locking device from engagement with arm B, and a spring for returning the tilted shaft and its arms into their normal positions, as and for the purpose specified.

2. In a safety mechanism for railways, the combination, with the track, a pivoted shaft extending across the same, and having arms B D, arranged at an angle to each other, the arm A, pivoted upon one side of the locomotive, the extent of movement of said arm in one direction being limited by a suitable stop, said arm operating to reverse or tilt the shaft, a spring-actuated dog operating to engage in a notch formed in the arm B, when the shaft is tilted, and lock the shaft and arms in the reversed position, and levers arranged upon the opposite side of the locomotive, connecting with a signaling device, one of the levers being adapted to strike the arm D while in its reversed position, of the pivoted arm F, located at a distance, connected with the locking device, and adapted to be struck by arm A, to withdraw the dog from engagement with arm B, and a spring for returning the shaft and its arms into their normal positions, said parts being arranged for operation as described, for the purpose specified.

3. In a safety mechanism for railways, the combination, with the track, a pivoted shaft extending across the same, and having arms B D, arranged at an angle to each other, the arm A, pivoted upon one side of the locomotive, the extent of movement of said arm in one direction being limited by a suitable stop, said arm operating to reverse or tilt the shaft,

a stop for limiting the extent of rotation of the shaft, a locking device operating to engage the arm B, when the shaft is tilted, and lock the latter and its arms in the reversed position, and levers arranged upon the opposite side of the locomotive, connecting with a signaling device, one of the levers being adapted to strike the arm D while in its reversed position, of the pivoted arm F, located at a distance, connected with the locking device, and adapted to be struck by arm A on the locomotive, to withdraw the locking device from engagement with arm B, and a spring for returning the tilted shaft and its arms into their normal positions, said parts being arranged for operation as described, for the purpose specified.

4. In a safety mechanism for railways, the combination, with the track, a pivoted shaft extending across the same, and having arms B D, arranged at an angle to each other, the arm A, pivoted upon one side of the locomotive, the extent of movement of said arm in one direction being limited by a suitable stop, said arm operating to tilt the shaft, a locking device operating to engage the arm B, when the shaft is reversed or tilted, and lock the same and its arms in the reversed position, and levers arranged upon the opposite side of the locomotive, connecting with a signaling device, one of the levers being adapted to strike the arm D while in its reversed position, of the pivoted arm F, located at a distance, a connection between said arm and the locking device, and means, as described, for taking up slack in said connection, said arm F being adapted to be struck by arm A on the locomotive, to withdraw the locking device from engagement with arm A, and a spring for returning the shaft and its arms into their normal positions, said parts being arranged for operation as described, for the purpose specified.

In testimony that I claim the foregoing I have hereunto set my hand this 6th day of February, 1885.

JULES DUROC.

Witnesses:

A. CERT,
A. RAPENT.