

C. J. HERMANN.
VISE.

No. 382,360.

Patented May 8, 1888.

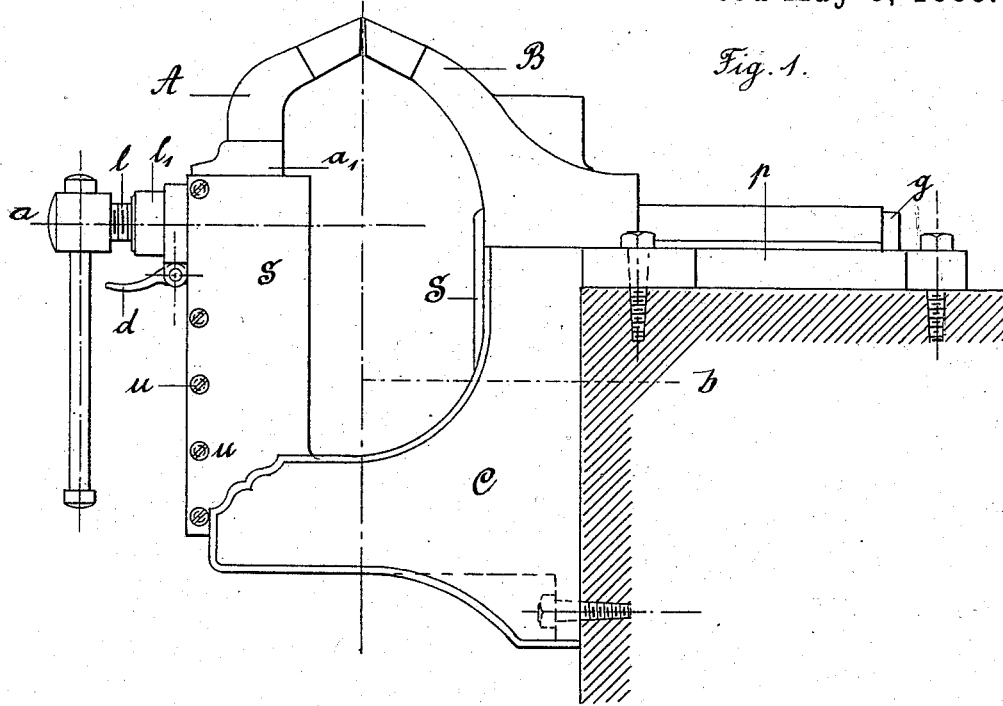

Fig. 1.

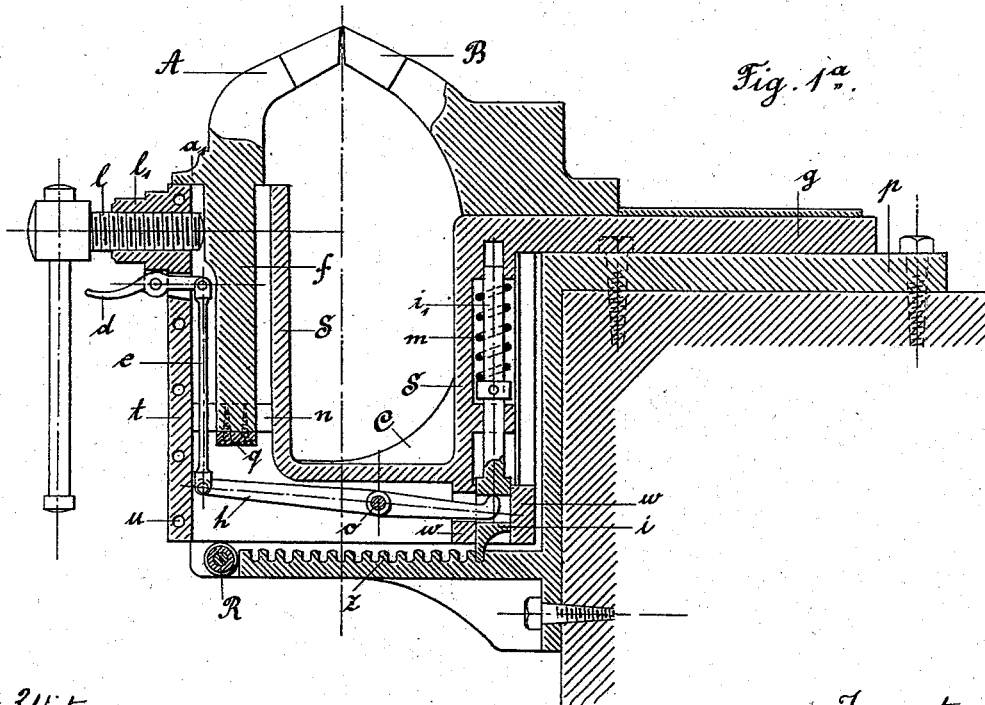

Fig. 1^a.

Witnesses:
Haddan
L. S. Neal

Inventor
Carl J. Hermann
 by *Haddan*
 his Attorney

C. J. HERMANN
VISE.

No. 382,360.

Patented May 8, 1888.

Fig. 2.

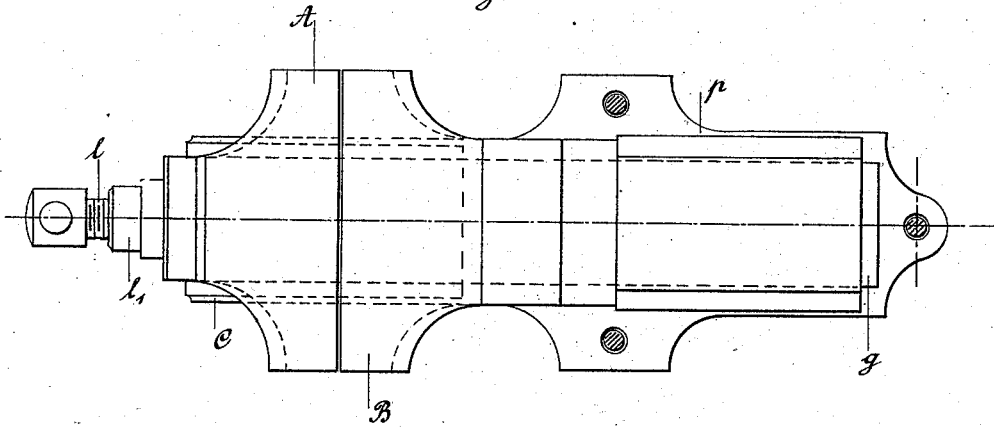

Fig. 3.

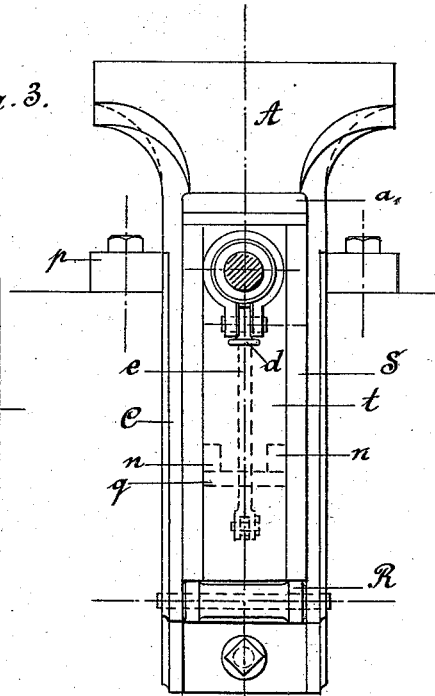
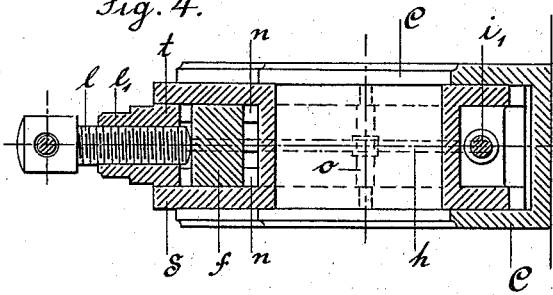

Fig. 4.



Witnesses.

W. H. Adams
J. A. Roe

Inventor.

Carl J. Hermann

by *W. H. Adams*

his Attorney

(Model.)

3 Sheets—Sheet 3.

C. J. HERMANN.
VISE.

No. 382,360.

Patented May 8, 1888.

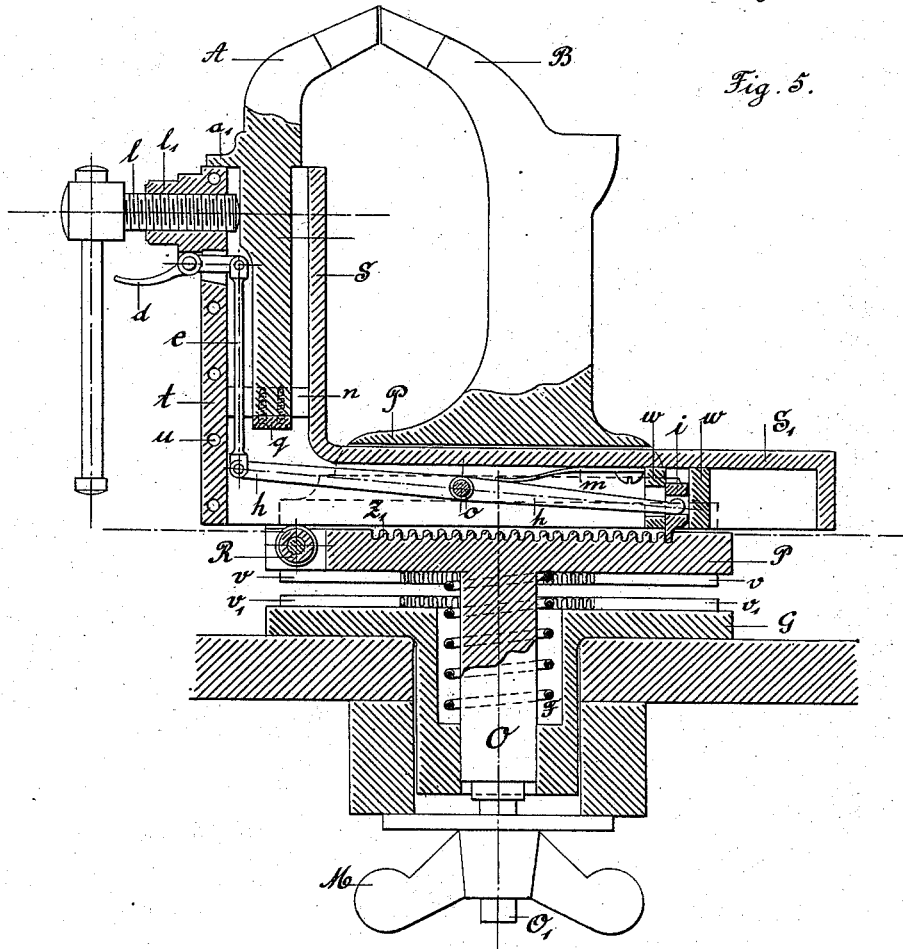

Fig. 5.

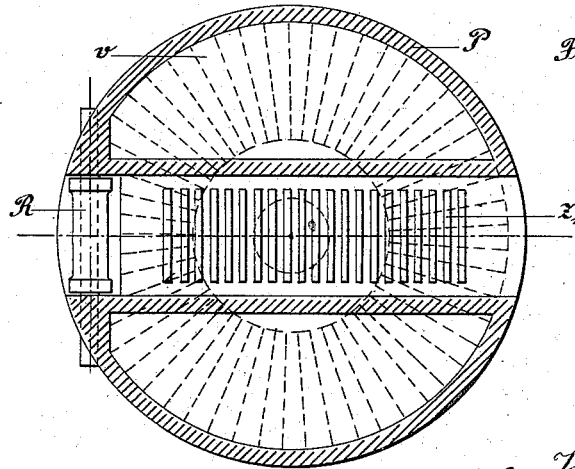

Fig. 6.

Witnesses:
W. H. Haddan
J. S. Mac.

Inventor
Carl J. Hermann
by *W. H. Haddan*
his Attorney.

UNITED STATES PATENT OFFICE.

CARL JOSEF HERMANN, OF BIELEFELD, WESTPHALIA, PRUSSIA, GERMANY.

WISE.

SPECIFICATION forming part of Letters Patent No. 382,360, dated May 8, 1888.

Application filed December 7, 1886. Serial No. 220,883. (Model.) Patented in Germany November 11, 1886, No. 40,233; in Austria-Hungary November 13, 1886, No. 44,696 and No. 9,611; in France November 30, 1886, No. 169,508; in Belgium November 30, 1886, No. 75,440, and in England December 1, 1886, No. 15,684.

To all whom it may concern:

Be it known that I, CARL JOSEF HERMANN, a subject of the German Emperor, and a resident of Bielefeld, in Westphalia, Prussia, Germany, have invented a new and useful Improvement in Vises, (for which I have obtained Letters Patent in the German Empire, No. 40,233, dated November 11, 1886; in Great Britain, No. 15,684, dated December 1, 1886; in France, No. 169,508, dated November 30, 1886; in Belgium, No. 75,440, dated November 30, 1886, and in Austria-Hungary, No. 44,696 and No. 9,611, dated November 13, 1886,) of which the following is a specification.

This invention relates to vises; and its object is to provide a vise with large range of holding capacity and readily and rapidly adjustable. A further object is to enable the vise to be set at any angle in a horizontal plane.

To this end my invention consists in the combination of parts, as hereinafter described, and specifically pointed out in the claims.

Referring to the accompanying drawings, Figure 1 represents a side elevation of my improved vise fixed to the edge of a bench. Fig. 1^a is a vertical section thereof, showing interior mechanism; Fig. 2, a plan view, and Fig. 3 a front elevation thereof. Fig. 4 is a horizontal section on line *a b*, Fig. 1. Fig. 5 shows, partly in section, a modification in which the vise is made adjustable. Fig. 6 is a horizontal section on line *x y*, Fig. 5.

Like letters refer to like parts throughout the figures.

The vise consists, essentially, of a fixed jaw, B, and a movable jaw, A. The fixed jaw B carries a foundation-plate, *p*, by means of which it can be firmly bolted to the upper surface of the bench. To or with the said fixed jaw B is fixed or formed in a position vertically below said jaw a bracket, C, extending horizontally forward from the front of the bench, and preferably bolted thereto. Within the bracket C, and supported partly on a roller, R, journaled in the fore or outer end thereof, slides the U-shaped casing S, holding in its forward arm the movable jaw A, and also containing mechanism, hereinafter described, for fixing the position of the said jaw. The casing S carries,

also, on the upper end of its rearward arm a horizontally and backwardly extending bar, *g*, sliding in a sleeve fixed to or forming part with the foundation-plate *p* of the fixed jaw B. In the bracket C, below the casing S, is arranged a rack, *z*, into the teeth of which projects the catch *i*, supported between guiding-blocks *w w* in the casing S and operated from the finger-lever *d* through the connecting-rod *e* and balance-lever *h*, pivoted at *o*. The pin *i* is normally held in the teeth *z* by the action of a spring, such as *m*. On pressing up the lever *d* the catch *i* will be disengaged from the rack *z* and the casing S will be free to move horizontally. The movable jaw A is fitted loosely into the forearm of the casing S in such a manner that it has a free play in the direction of the opposite jaw for an amount equal at least to the pitch of the teeth of the rack *z*. The jaw A is supported partly by the collar *a'*, formed thereon, resting on the upper end of the casing S and partly on rails *n*, arranged at its lower end and fixed to the sides of the casing S. The lower end of the jaw A is adapted in shape to the rails *n*, as shown in Fig. 3, and to it is screwed the plate *q*, catching under the rails *n*, so that when another jaw is to be substituted for the jaw A the latter can be removed from the casing by first removing the plate *q*.

The jaw A is adjusted in the casing S by the spindle *l*, operated in the usual manner.

The operation of this vise is as follows: The hand is placed round the spindle *l*, the lever *d* lifted, and the casing S pulled out to a sufficient extent to admit the article to be held between the jaws. The casing S is pushed back as far as possible and the lever *d* released. The catch *i* will then fall into one of the recesses in the rack *z* and hold the casing S firmly. The spindle is then turned until the article is held sufficiently firmly between the jaws.

In the modification shown in Fig. 5 the casing S is L-shaped and the bar *g* is dispensed with. The horizontal arm of the casing S is adapted to slide in the base of the fixed jaw, the rack *z* and the roller R being placed thereunder, as shown. In Figs. 5 and 6 are further shown the means for setting the vise at any

angle in a horizontal plane. To the bench is fixed a disk, G, having in its center a cavity, in which is adapted to slide the bolt O, fixed vertically to the under surface of the frame P of the vise. The upper surface of the disk G and the under surface of the plate P are provided with corresponding equidistant radial ridges, *v'* and *v*, respectively, said ridges being adapted to lock together when the plates P and G are held together. The bolt carries a screw-spindle, O', with thumb-nut M, and is also surrounded by the helical spring F, tending to force the plates P and G apart.

In setting the vise at any angle the thumb-nut M is partly unscrewed, allowing the spring F to lift the plate P out of engagement with the plate G. The vise can now be turned to the necessary angle and the screw M screwed up. The plate P will then engage the plate G in the desired position.

What I claim is—

1. The combination of a jaw, B, having a socket in the frame thereof and a rack, *z*, in said socket, with an arm, S, having an extension guided in said socket, a tooth in said extension adapted to gear with said rack, lever mechanism for lifting said tooth, and a jaw, A, adjustable in said arm in a direction to and from said jaw B, for the purpose set forth.

2. The combination, of a jaw, B, having a socket in the frame thereof and a rack, *z*, in said socket, with an arm, S, having an extension guided in said socket, a tooth in said extension adapted to gear with said rack, a spring for holding said tooth in engagement, bell-crank lever *h*, rod *e*, and lever *d*, for raising said tooth, a removable jaw, A, adjustable in said arm S in a direction to and from said jaw B, and screw-spindle *l*, for adjustment of said jaw A, in the manner set forth.

3. The combination of a jaw, B, a base, P, integral therewith, a socket in said base, an arm, S, having an extension movable in said socket, a jaw, A, in said arm, and means for relative adjustment of jaws A and B, with a spindle, O, on said base P, ribs *v* on said base, plate G, ribs *v'* on said plate, spring F, and nut M, for the purpose set forth.

In testimony whereof I have signed this specification in the presence of two subscribing witnesses.

CARL JOSEF HERMANN.

Witnesses:

KRÜSEMANN, II,
KRÜSEMANN, I.