

(No Model.)

13 Sheets—Sheet 1.

G. M. PETERS.  
CARTRIDGE LOADING MACHINE.

No. 383,905.

Patented June 5, 1888.

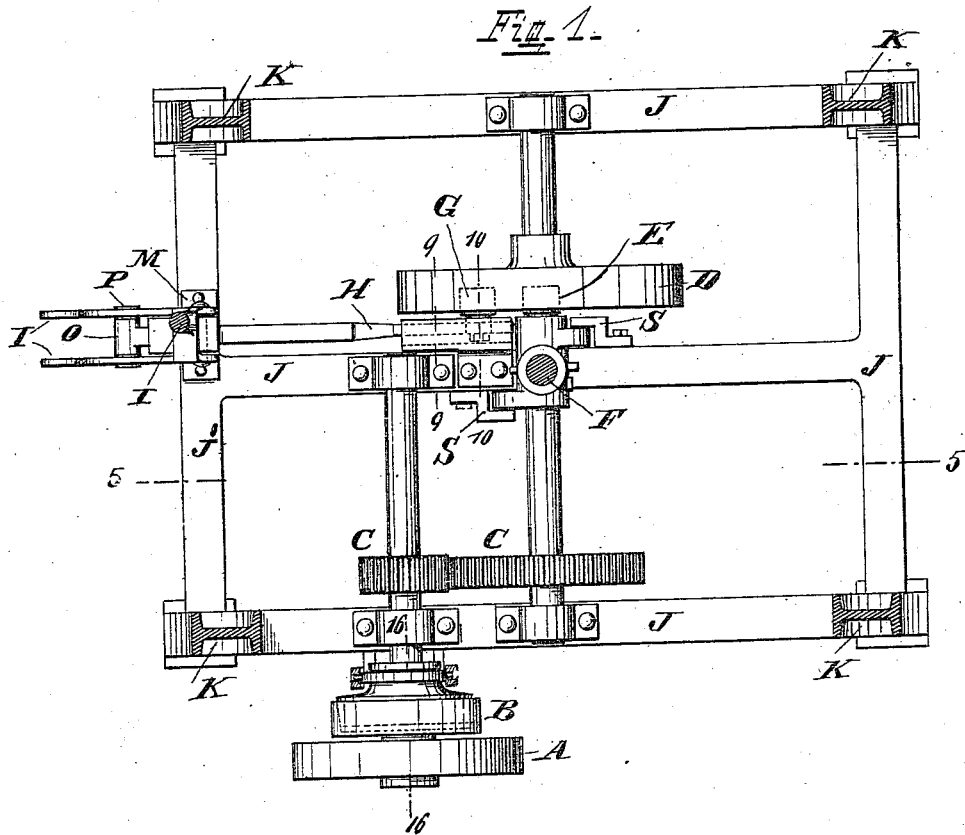
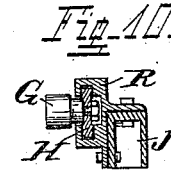
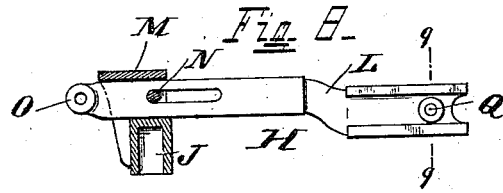
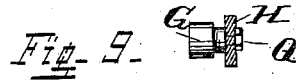

Attest.  
Carl Spengel.  
Jno. Emmett,

Inventor.  
G. M. Peters.  
J. H. MacDonalld.  
Atty.

(No Model.)

13 Sheets—Sheet 2.

G. M. PETERS.  
CARTRIDGE LOADING MACHINE.

No. 383.905.

Patented June 5, 1888.

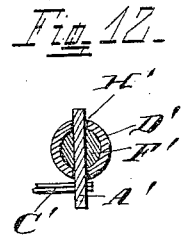
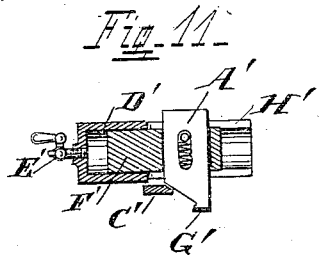
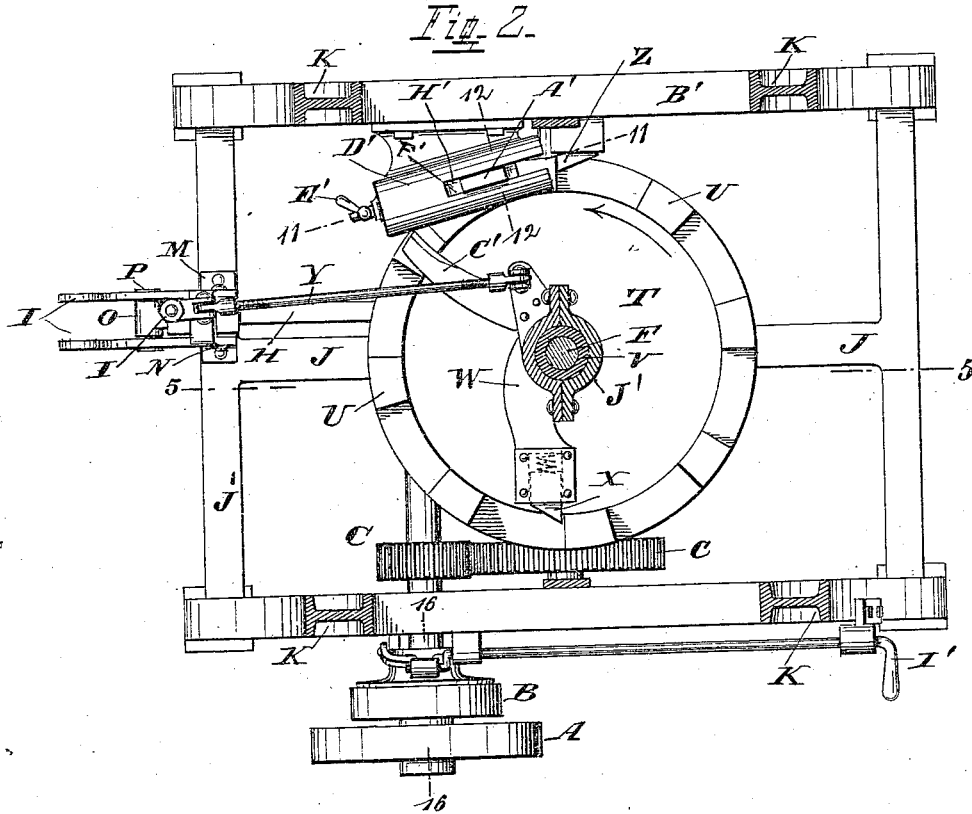

Attest.  
 Carl Spengel.  
 Jno. Emmett.

Inventor,  
 G. M. Peters.  
 Atty,  
 Dr. Macdonald.

(No Model.)

13 Sheets—Sheet 3.

G. M. PETERS.

CARTRIDGE LOADING MACHINE.

No. 383,905.

Patented June 5, 1888.

*Fig. 3.*

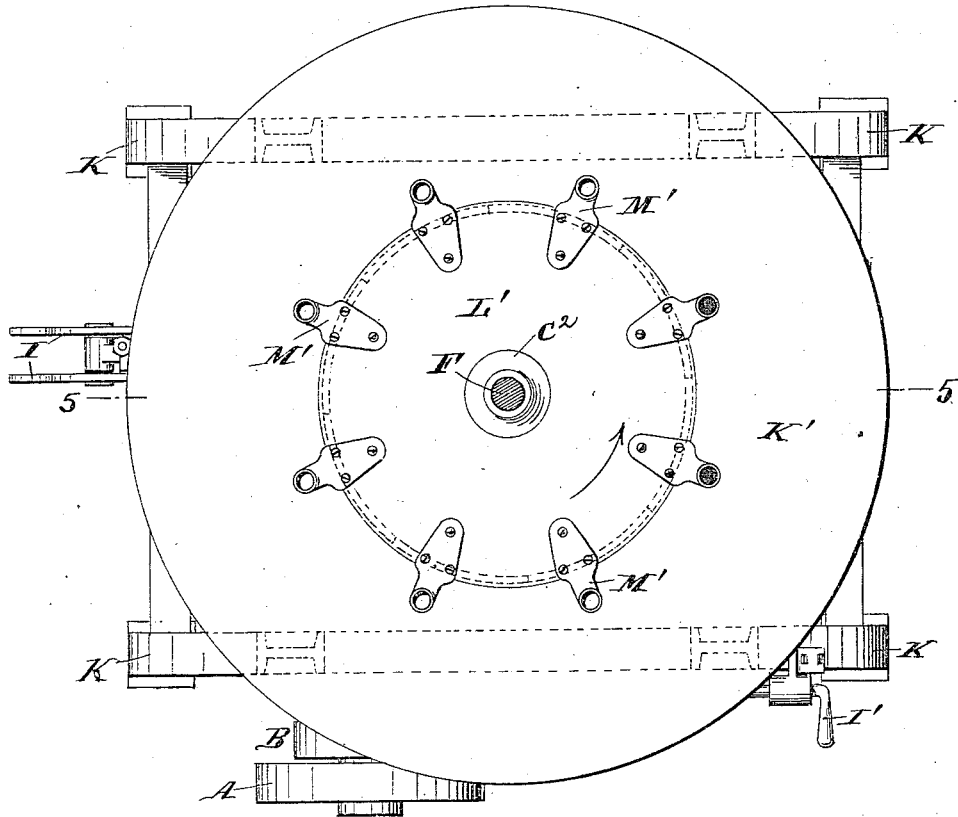

*Fig. 13.*

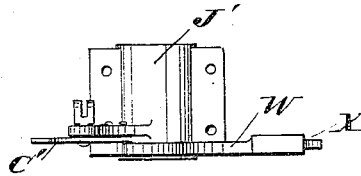

*Attest.*  
*Carl Spengel.*  
*Jno. Emmett.*

*Inventor.*  
*G. M. Peters.*  
*J. H. MacDonald.*  
*Atty.*

(No Model.)

13 Sheets—Sheet 4.

G. M. PETERS.

CARTRIDGE LOADING MACHINE.

No. 383,905.

Patented June 5, 1888.

Fig. 4.

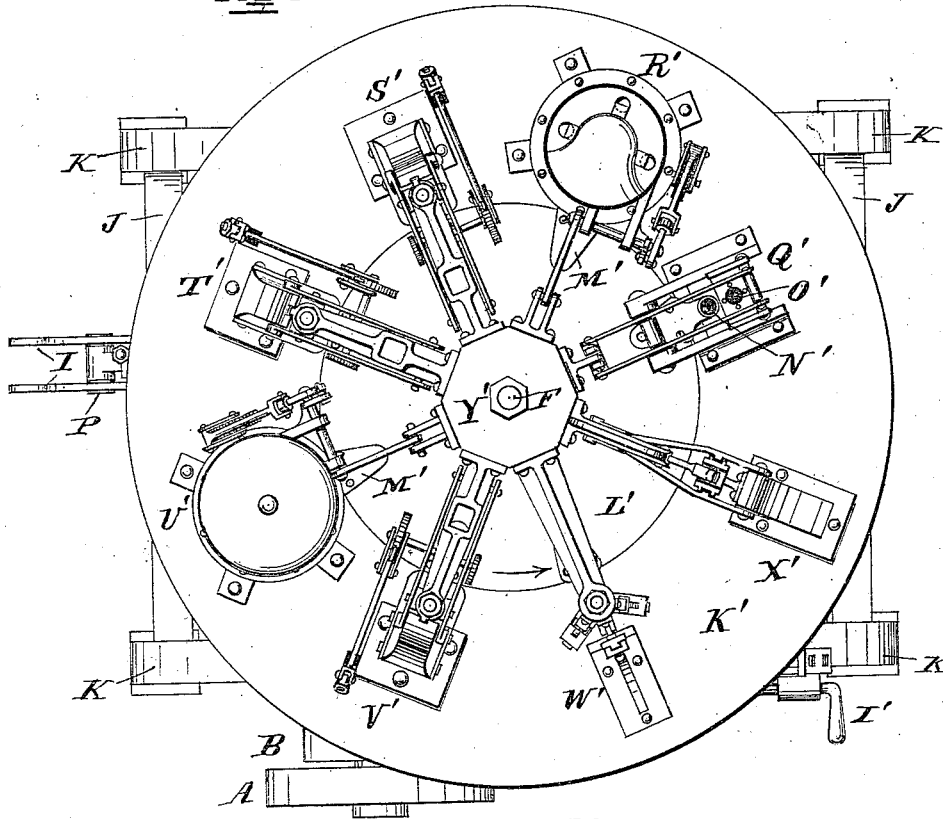
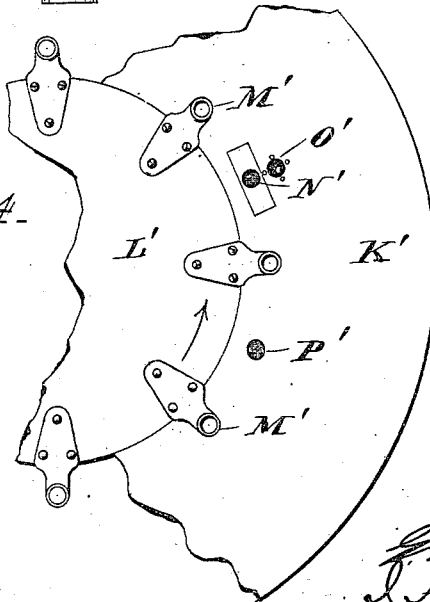

Fig. 14.



Attest.  
 Carl Spengel,  
 Jno. Emmett,

Inventor.  
 G. M. Peters.  
 J. H. MacDonald  
 Atty.

(No Model.)

13 Sheets—Sheet 5.

G. M. PETERS.  
CARTRIDGE LOADING MACHINE.

No. 383,905.

Patented June 5, 1888.

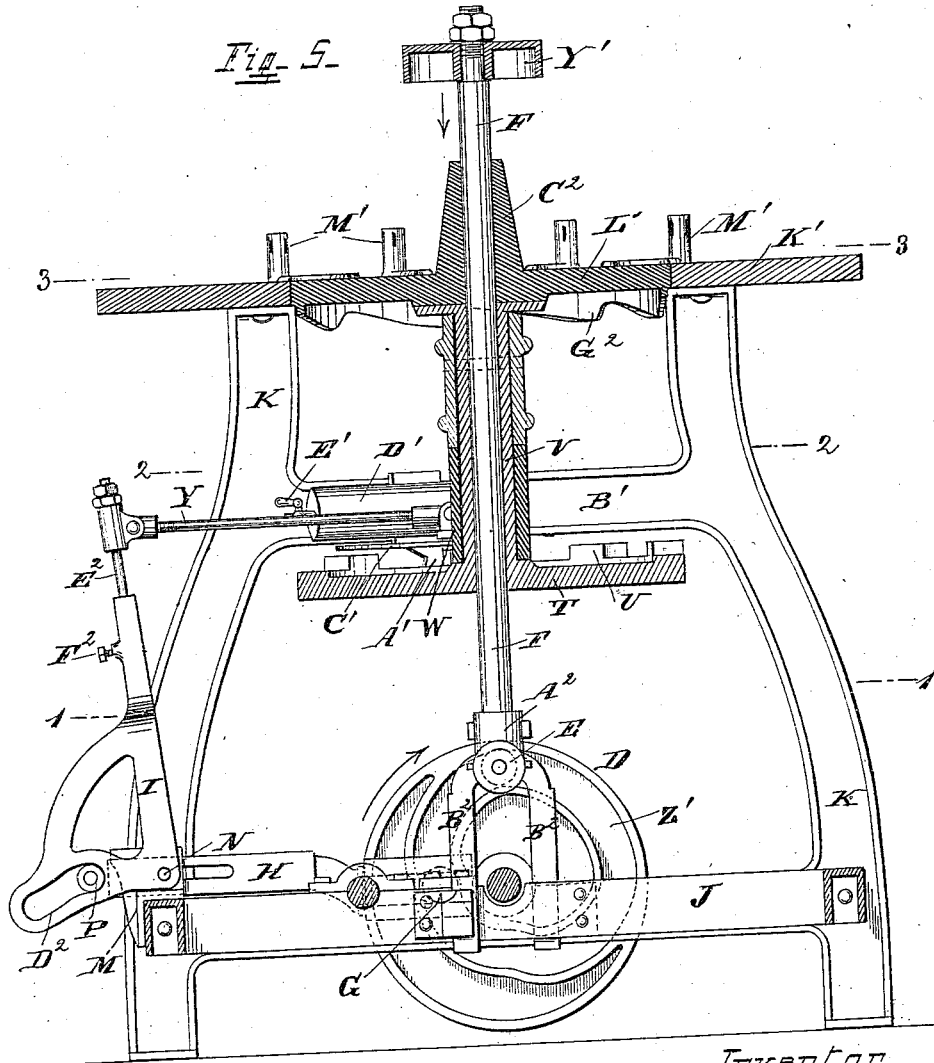
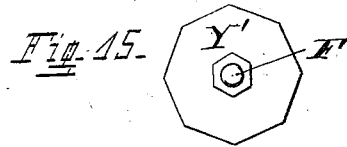

Inventor.

Attest.  
 Carl Spengel.  
 Jno. Emmett.

G. M. Peters.  
 J. H. Macdonald,  
 atty.

(No Model.)

13 Sheets—Sheet 6.

G. M. PETERS.

CARTRIDGE LOADING MACHINE.

No. 383,905.

Patented June 5, 1888.

*Fig. 6.*

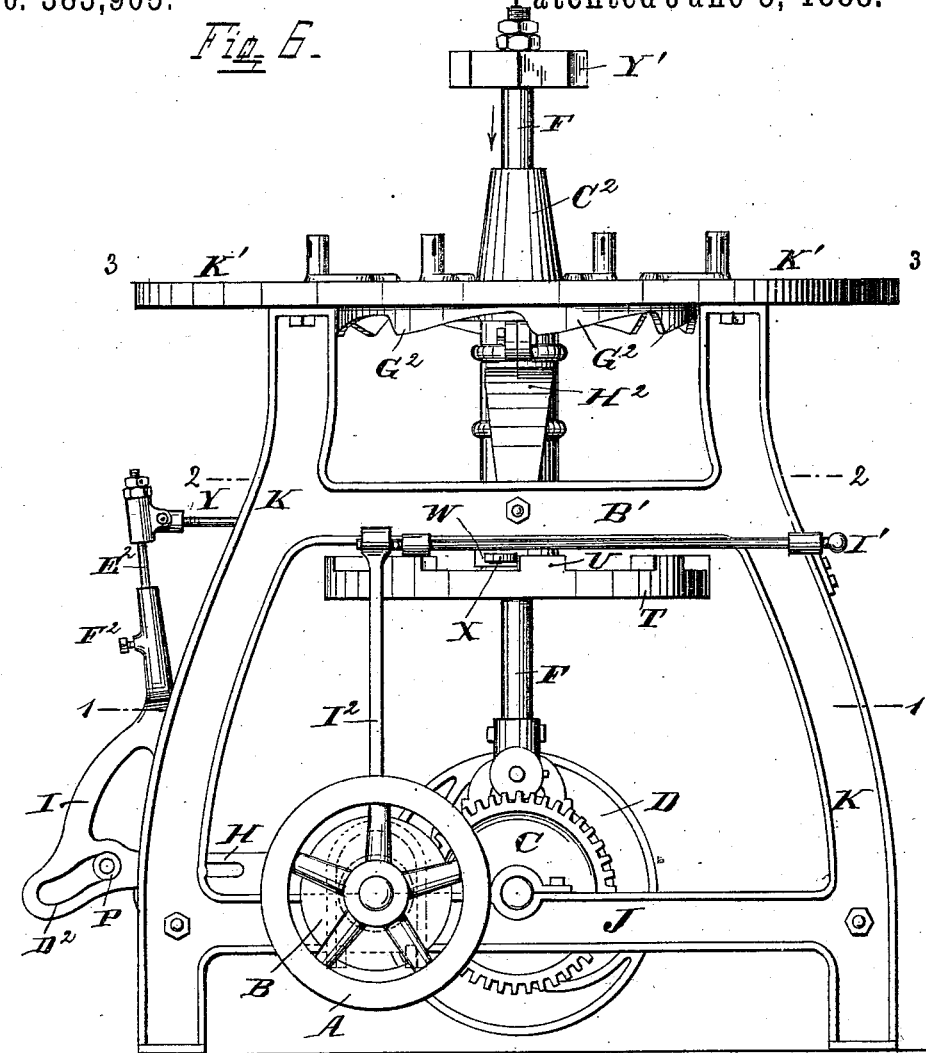

*Fig. 1 E.*

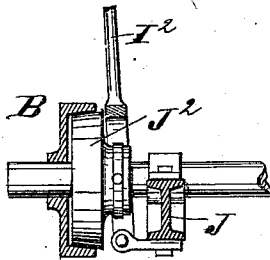

Attest.  
 Carl Spengel.  
 Jno Emmett.

Inventor,  
 G. M. Peters.  
 J. H. MacDonell,  
 Atty.



G. M. PETERS.  
CARTRIDGE LOADING MACHINE.

No. 383,905.

Patented June 5, 1888.

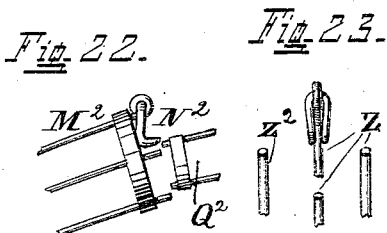
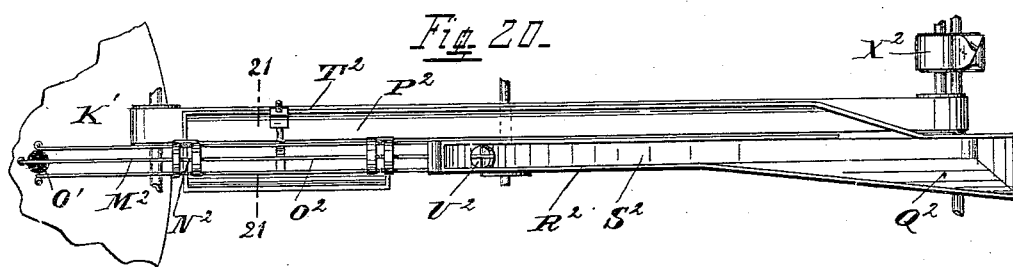
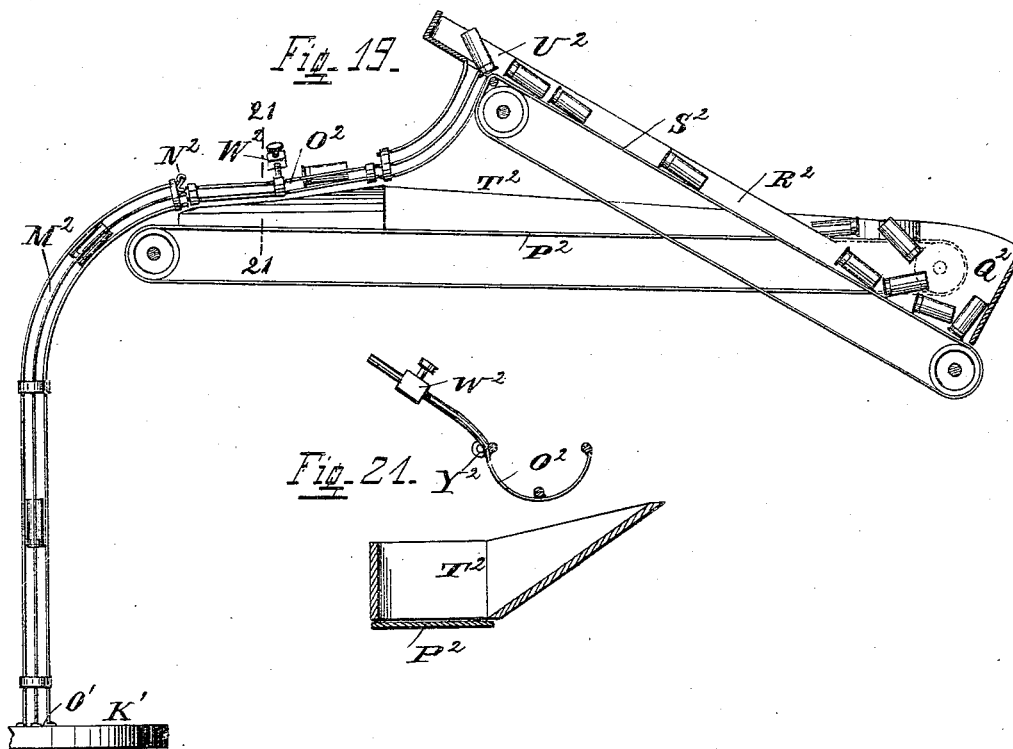

Attest.  
 Carl Spengel.  
 Jno. Emmett.

Inventor,  
 G. M. Peters.  
 J. H. MacDonnell  
 Atty.



G. M. PETERS.

CARTRIDGE LOADING MACHINE.

No. 383,905.

Patented June 5, 1888.

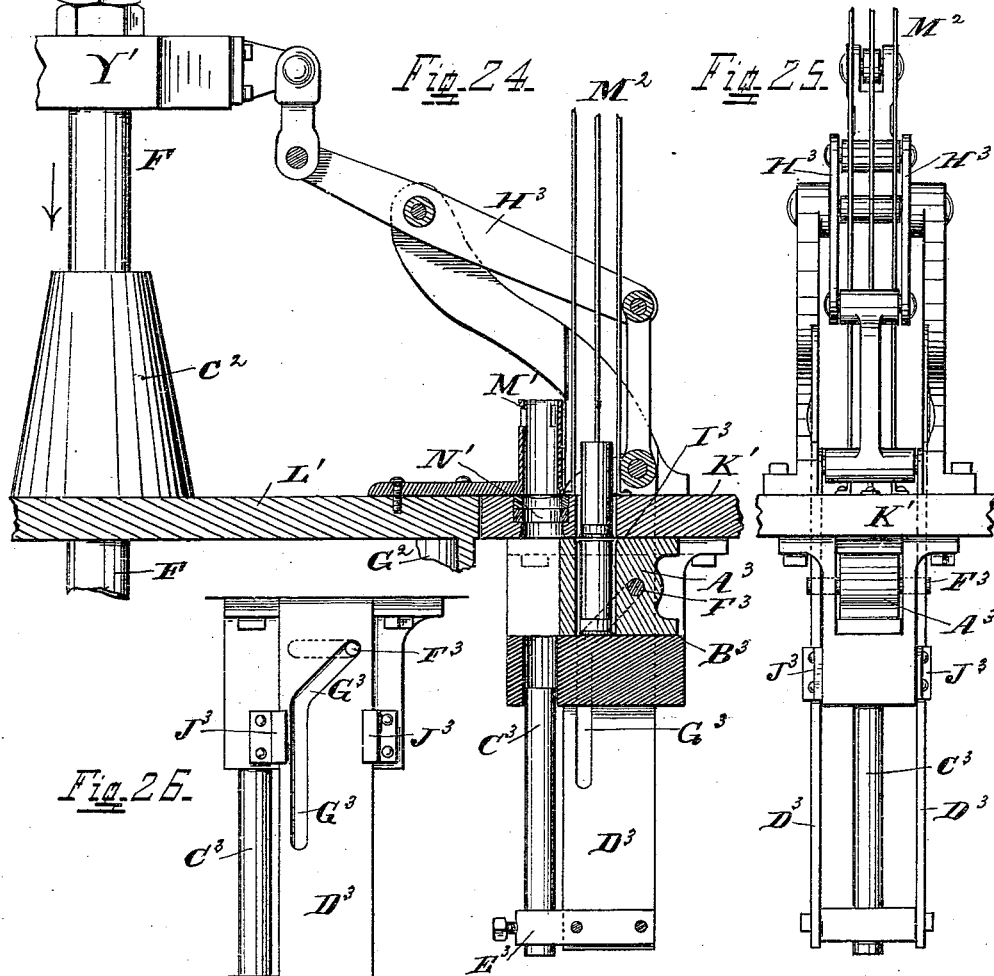

Fig. 26.

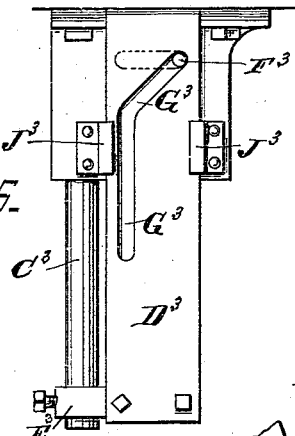

Fig. 27.

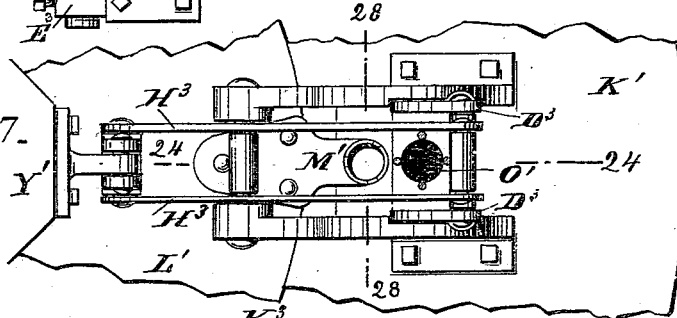
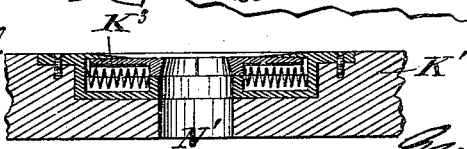

Fig. 28.



Attest.  
 Carl Spengel.  
 Jno. Emmett.

Inventor.  
 J. H. MacDonald, Att'y.

(No Model.)

13 Sheets—Sheet 10.

G. M. PETERS.

CARTRIDGE LOADING MACHINE.

No. 383,905.

Patented June 5, 1888.

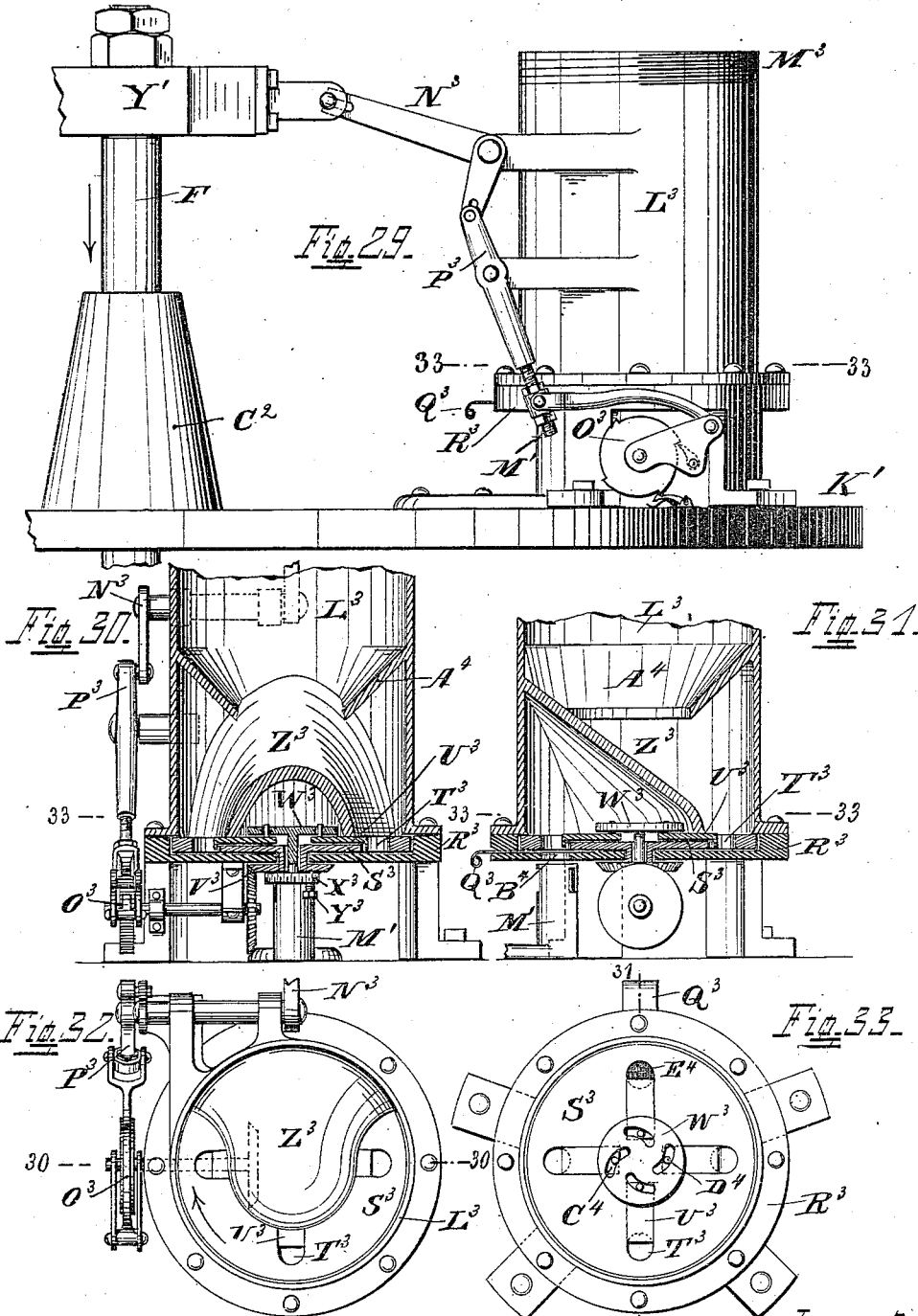

Attest.  
 Carl Spengel.  
 Jno Emmett.

Inventor.  
*G. M. Peters*  
 J. H. MacDonald,  
 Atty.

G. M. PETERS.

CARTRIDGE LOADING MACHINE.

No. 383,905.

Patented June 5, 1888.

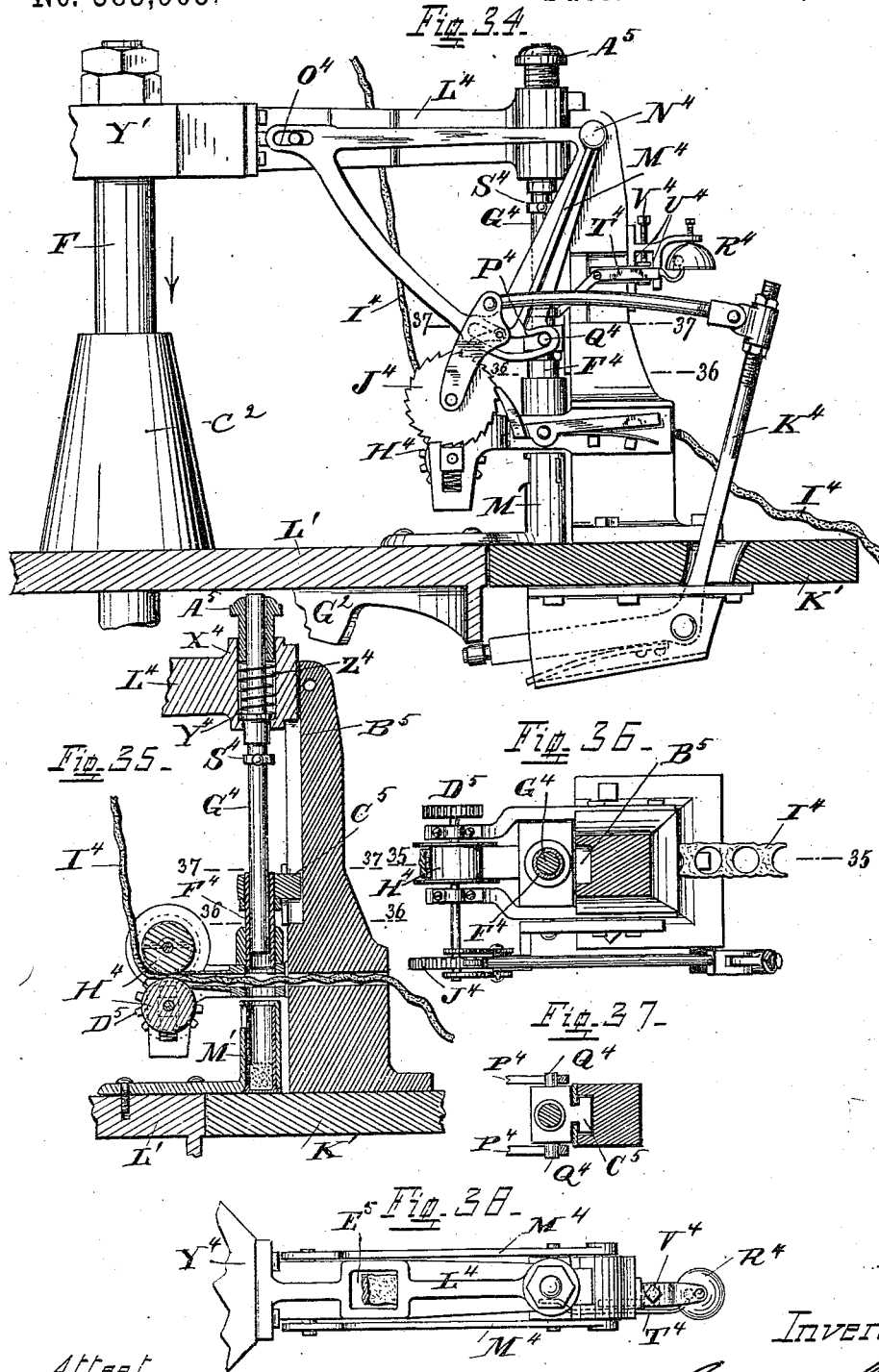

Attest.  
 Carl Spengel,  
 Jno. Emmett.

Inventor.  
 G. M. Peters  
 J. H. MacDougal atty.

(No Model.)

13 Sheets—Sheet 12.

G. M. PETERS.

CARTRIDGE LOADING MACHINE.

No. 383,905.

Patented June 5, 1888.

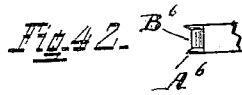
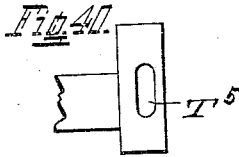
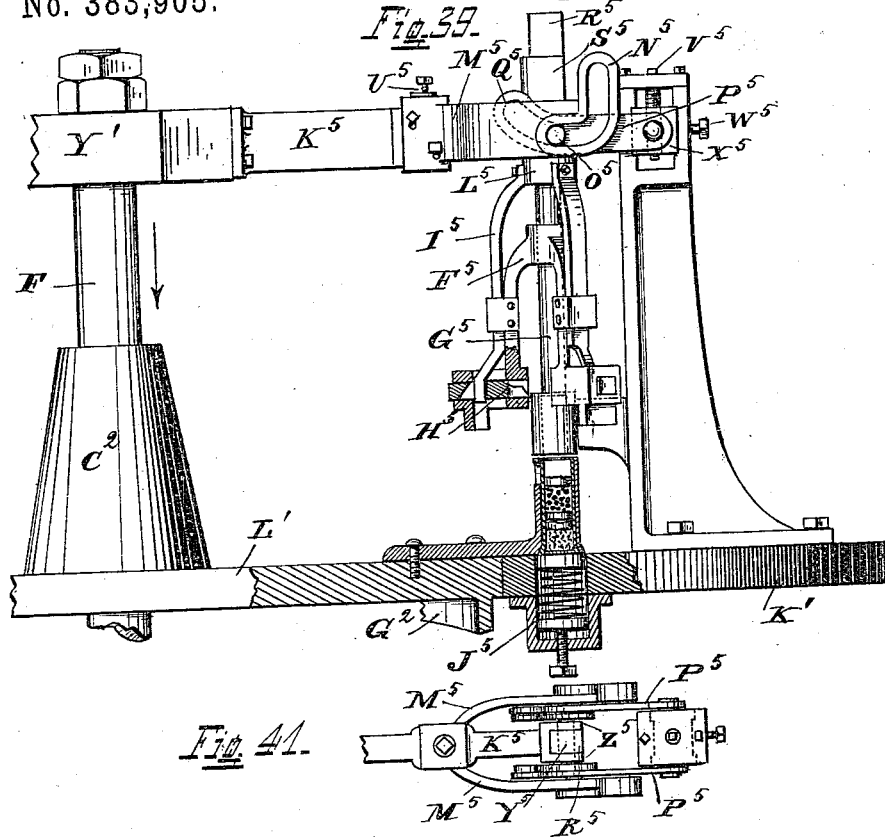

Attest.  
 Carl Spengel.  
 Jno. Emmett.

Inventor.  
*G. M. Peters.*  
 J. H. MacDonald, Atty.

(No Model.)

13 Sheets—Sheet 13.

G. M. PETERS.

CARTRIDGE LOADING MACHINE.

No. 383,905.

Patented June 5, 1888.

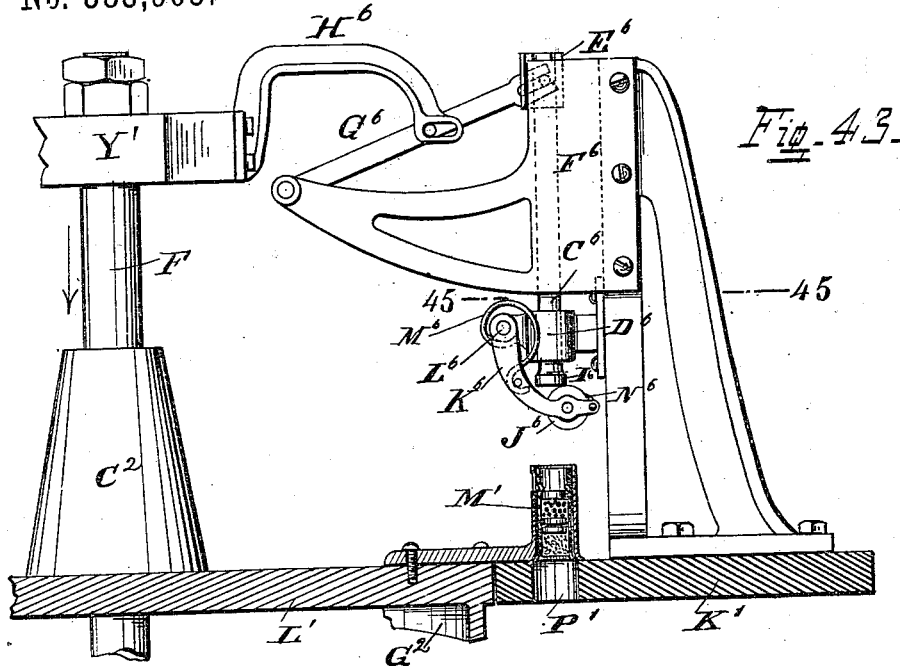

Fig. 43.

Fig. 44.

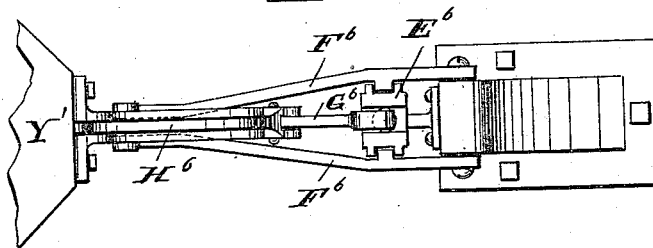
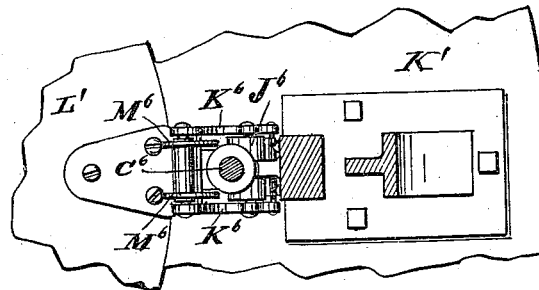

Fig. 45.



Inventor.

Attest.  
Carl Spengel.  
Jno. Emmett.

G. M. Peters.  
J. H. MacDonald, Atty.

# UNITED STATES PATENT OFFICE.

G. MOORE PETERS, OF XENIA, OHIO.

## CARTRIDGE-LOADING MACHINE.

SPECIFICATION forming part of Letters Patent No. 383,905, dated June 5, 1888.

Application filed September 10, 1887. Serial No. 249,301. (No model.)

### *To all whom it may concern:*

Be it known that I, G. MOORE PETERS, a citizen of the United States, residing at Xenia, in the county of Greene and State of Ohio, have invented certain new and useful Improvements in Cartridge-Loading Machines; and I do declare the following to be a full, clear, and exact description of the invention, such as will enable others skilled in the art to which it appertains to make and use the same, reference being had to the accompanying drawings, and to the letters and figures of reference marked thereon, which form a part of this specification.

My invention relates to cartridge-loading machines, and is an improvement on that granted to me in Letters Patent No. 360,013, of March 29, 1887. The main features of the machine therein described were a stationary table on which were placed the various filling devices, eight in number; an intermitting rotating table inside the stationary table and on a plane with it for carrying the cases containing the shells; a solid perpendicular central shaft actuating the devices on a stationary table; a hollow shaft surrounding as a sleeve the solid shaft to which the rotating table is attached, and all operated from beneath by a single cam-wheel.

The machine now presented simplifies mechanically the methods for carrying out the principles heretofore established.

The various devices will be described in detail and in their general relation to each other, and as illustrated in the accompanying drawings, in which—

Figure 1 is a top plan view of the driving apparatus; Fig. 2, a top plan view of the devices for operating the rotating table; Fig. 3, a similar view of the tables; Fig. 4, a top plan view of the table with the filling devices; Fig. 5, a side elevation, partly in section, of the actuating mechanism; Fig. 6, a side elevation of the actuating mechanism with the filling devices removed; Fig. 7, a front view of the actuating mechanism; Fig. 8, Sheet 1, a side view of the lever-operating slide; Fig. 9, Sheet 1, cross-section of the roller for operating said slide; Fig. 10, Sheet 1, a section of the slide-bearing bolted to cross piece of the main frame; Fig. 11, Sheet 2, a side section of one of the spring-catches. Fig. 12, Sheet 2, an end section of same; Fig. 13, Sheet 3, a side view of

the actuating-lever W; Fig. 14, Sheet 4, a plan view showing the cases midway between the filling devices; Fig. 15, Sheet 5, a top view of the head-block; Fig. 16, Sheet 6, a sectional view of the friction-clutch; Figs. 17 and 18, Sheet 7, side and end views, respectively, of the shaft and its connection with the cross-frame; Fig. 19, Sheet 8, a side view of the shell-feeder; Fig. 20, Sheet 8, a top view of the feeder; Fig. 21, Sheet 8, a cross-section of the bridge on the feeder; Fig. 22, Sheet 8, a detail view of the hook on the feeder; Fig. 23, Sheet 8, an end view of the cage on the feeder; Fig. 24, Sheet 9, a section of the shell-placer; Fig. 25, Sheet 9, a front view of same; Fig. 26, Sheet 9, a side view of same; Fig. 27, Sheet 9, a top view of same; Fig. 28, Sheet 9, a sectional view of the opening for the passage of the shell to the filling-case; Fig. 29, Sheet 10, a side view of the powder and shot filling devices; Fig. 30, Sheet 10, a cross section through the center of the machine; Fig. 31, Sheet 10, a side sectional view showing the sloping bottom; Fig. 32, Sheet 10, a top view of the hopper; Fig. 33, Sheet 10, a top view of the base with the hopper removed; Fig. 34, Sheet 11, a side view of the wad cutter and placer; Fig. 35, Sheet 11, a side sectional view of the cutter with the rammer inside; Figs. 36 and 37, top sectional views of the cutter and head-block; Fig. 38, a top view of the levers for operating the cutters; Fig. 39, a side view of the indenter; Fig. 40, plan view of the slotted arm-head; Fig. 41, a top view of the rammer-head and slotted arms; Fig. 42, a detail view of the indenter; Fig. 43, a side view of the extractor; Fig. 44, a top view of the supporting-frame and bearings for head-block for the extracting-rod, and Fig. 45 a top view of the inking-roller and actuating mechanism.

The same parts are designated by the same letters of reference throughout.

Referring more particularly to the drawings, in Fig. 1 the driving apparatus is shown in plan view, and consists of a fly or balance wheel, A, a friction-pulley, B, to which a driving-belt is secured, meshing gear-wheels C, which transmit movement to a cam-wheel, D, which in turn carries the roller E, for operating the central shaft, F, and the roller G, for operating the horizontal slide H, which in turn actuates the lever I. The shaft F is pro-

vided with suitable bearings, S. A cast-iron frame, J, supports these parts and rests on legs J'. The slide H, Fig. 8, is bent downward at L, in order to bring the roller G on a line with the cutter of the cam-wheel D, and is provided with a bearing, M, at its rear end, which bearing is bolted to the frame J. The lever I is pivoted at point N, the bolt forming same passing through a slot in the slide H to accommodate the backward and forward movement of the slide. A boss, O, is secured at either side of lever I, and has a bolt passing through it for holding rollers P, which move in the ogee slot of the lever I. The roller G is pivoted to slide H at point Q, Fig. 9. The forward bearing of said slide is bolted at R, Fig. 10, to the cross-piece of the main frame J.

The devices for operating the rotating table, Fig. 2, consist of a lug-plate, T, having eight lugs, U, carefully spaced on a milling-machine to give eight equal movements necessary to complete a revolution of the rotating table carrying the shell-cases. This lug-plate is connected to the table by means of the hollow shaft surrounding the solid central shaft, F. A lever, W, is pivoted about the hollow shaft, and has a horizontal movement back and forth equal to one-eighth of a revolution. The outer end of this lever is provided with a sloping spring-catch, X, which as the lever moves forward takes hold of the lugs U, causing plate T to turn. As the lever W is thrown backward, the sloping slide of the catch X strikes the next lug and pushes the catch back into its socket until it gets behind the lug, when it again flies out ready to take a new hold. The lever W is operated by the lever I through the intervention of links Y. This link is screw-threaded at its ends, so that it may be lengthened or shortened, as explained in my former patent. It is necessary to stop the rotating table at one-eighth of its revolution and hold it exactly at that point while the filling devices are in operation. To accomplish this two spring-catches, A' and Z, are provided to embrace the lug U on either side. These catches have their bearings bolted to the cross-piece B' of the frame of the machine, and are made adjustable by means of slotted holes, so that the catches can be set exactly to the point required. The catch Z acts horizontally and the catch A' perpendicularly, A' stopping the movement of the lug-plate and Z preventing its rebound. It will be seen that catch Z is operated in the same manner as catch X. The catch A' is raised over the lugs by means of the arm C', extending from the lever W, which strikes the sloping side of the catch, lifts it as lever W is thrown back, and holds it up until the lug-plate is moved forward, carrying the rejected lug underneath it, when the catch drops and is again ready to be struck by the next lug. The slope of the catch A' and the manner in which the arm C' strikes and lifts it are more fully shown in detail, Fig. 11. The speed at which the lug-plate T revolves would cause the lugs U (if not prevented) to

strike the catch A' with such force as to jar the machine. To prevent this an air-cushion connected with catch A' is provided. This consists of a horizontal cylinder, D, placed at a proper angle with reference to the circular movement of the lug-plate T. The cylinder is solid at its rear end, excepting a small aperture into which is fitted a stop-cock, E, to regulate the escape of air. This cylinder is smoothly bored, and into it is fitted an air-tight piston, F', Fig. 11, and to this piston is attached the catch A'. It is necessary to set this piston or draw it out for each lug, so that it may be drawn back against the air-cushion when it is struck. This is accomplished by the arm C', which not only lifts the catch A', but carries it forward to the opposite edge of the lug by taking hold of the notch or shoulder G'. The catch A', extending above and below the piston, requires a slot, as H', Fig. 12, to be cut through the cylinder of sufficient length to accommodate the movement in and out of piston F', and also serves to hold catch A' in a perpendicular line. At the same time the bearings of the piston are preserved throughout its movement. A crank or lever, I', is arranged at one side of the machine for the convenience of the operator in throwing in or out the friction-clutch which takes hold of the pulley B.

In Fig. 13 I have a side view of lever W, showing the manner in which the arm C' is attached and the general slope of the casting, the lever being cast with one-half of the boxing J', which surrounds the hollow shaft V.

The stationary table, Fig. 3, supports the filling devices, and within this rotates a table, L', to which are attached the eight cases M', for carrying the shells during the operation of filling. These cases are open at top and bottom, and do not differ materially in structure from those described in Letters Patent No. 360,043. As here shown, the cases are supposed to stand under the various filling devices. To show the intermediate positions I will refer to Fig. 14, where the cases are supposed to be standing midway between the filling devices, exposing to view openings in the table, as follows: N' represents the opening through which the shell-placer (hereinafter shown) thrusts the shells up into the cases M' as into the breach of a gun; O', the openings for carrying the shells from the hopper to the shell-placer; P', the opening through which the shells when loaded are extracted from the cases. As in my former patent, I first start with a placed shell and then traverse the various filling devices to the extractor. The arrangement of the filling devices placed in their proper order is shown in plan, Fig. 4. Starting with the placer Q, a shell is thrust upward into the holder, next passes to the powder-filler R, then to pasteboard-wad cutter and placer S, thence to the felt-wad cutter and placer T, next to the shot-filler U, thence to pasteboard-wad cutter and placer V, then to indenter W, and, finally, to extractor X'. All of these devices are attached to an octagonal head-block, Y', on top of the

central shaft, F, and are thus all operated in common. These devices will be hereinafter described in detail.

Figs. 5, 6, and 7 show the several features of the central shaft and table actuating devices. In these figures the filling devices on the stationary table are removed.

Referring to Fig. 5, Disthecam-wheel, in which play rollers E and G, the former operating the central shaft, F, and the latter the rotating table L'. These rollers are actuated by the cam Z'. This cam has a variation in and out from the center of four inches. It is arranged on quarters. Two quarters conform to the center—one near it, the other four inches farther away—one of the other quarters bringing the rollers toward the center, the other taking them from the center. The rollers are also arranged on quarters or at right angles to each other, E at the top giving the shaft F a perpendicular movement, G at the side giving the slide H a horizontal movement. Thus it will be seen that when roller E is in movement roller G is at rest, and vice versa. The roller E and shaft F are keyed to cast-iron base A<sup>2</sup>, which has two arms or prongs having bearings on the cross-piece J. This gives steadiness to the roller E while being acted upon by the cam and prevents the shaft F from turning. This shaft also has bearings through the hollow shaft V, and extends through the boss C<sup>2</sup>, cast on the rotating table L', and having at its upper end the octagonal head-block Y', resting on a shoulder and firmly held down by a nut and screw. The roller G moves the slide H, which operates the lever I, and this in turn, through link Y, operates the lever W, which throws the lug-plate T, and so the rotating table L', operating also by means of arm C the catch A' and air-cushion D'. The lever I is of peculiar construction. It is bell-cranked in form, and midway down it divides into two blades, one on either side of slide H. These blades have uniform ogee slots D<sup>2</sup>, in which play rollers P, connected with the slide H. These slots serve as cams for moving the lever I. This method is adopted in order to give ease to the starting and stopping of the rotating table L'. It is also necessary in order to operate the air-cushion D', which requires a slowing down of the movement as the air-cushion is compressed. This lever is capable of being lengthened or shortened by means of the bar E<sup>2</sup>, sliding in and out of a socket, and is held by the set screw F<sup>2</sup>. The link Y has universal-joint connections, by which the perpendicular and horizontal circular movements of the levers I and W are accommodated to each other. The toothed flange G<sup>2</sup>, east on the under side of the rotating table L', is for the purpose of operating the feed-wheels of the wad-cutters.

In Fig. 6 the manner in which the catch X of the lever W takes hold of the lugs U is more clearly shown. So is also the toothed flange G<sup>2</sup>. H<sup>2</sup> is an end view of the support of the rotating table L', with its attachments of hollow shaft V and lug-plate T. I<sup>2</sup> gives the con-

nection between the crank-lever I' and the friction-pulley B. In Fig. 16 I have a sectional view of the manner in which the friction-clutch J<sup>2</sup> takes hold of the pulley B.

In Fig. 7 there is shown more fully the connection of lever I<sup>2</sup> with the clutch J<sup>2</sup>; also a side view of the base A<sup>2</sup> of shaft F with spread of prongs B<sup>2</sup> and connection of roller E. (Vide also Figs. 17 and 18.) K<sup>2</sup> shows the divisions of lever I into the two blades before described.

W is the lever for throwing the lug-plate T; X, the catch for taking hold of lug U; J', the fastening to hollow shaft; C', the arm extending from lever W for striking the catch A' and operating the air-cushion D', and Z the catch for preventing rebound, its support being attached to cross frame B'. The relation of the two catches is here seen, the support H<sup>2</sup> of the rotating table L' being bolted at both ends to the cross-frame B'.

Having described the general mechanism for attaching the table carrying the shell-holders, I will now describe the apparatus for delivering the shells to the holders.

The shell-feeder (shown in side view, Fig. 19) is intended to be placed in the second story of the factory, or at a considerable elevation above the machine. It may be operated by a belt connected with the shaft of the cam-wheel D, or by means of other connections more directly with the driving-power. The main features are substantially such as described in my former patent. The new features are a wire cage, M<sup>2</sup>, for conducting the shells, thus permitting the operator to see if the feeding is being properly done; a hook, N<sup>2</sup>, for detecting and arresting a shell that may be entering wrong end foremost; a tilting bridge, O<sup>2</sup>, for throwing out shells arrested by the hook N<sup>2</sup>, or an excess of shells, should the feeding be done fast, and a returning belt, P<sup>2</sup>, for carrying back to the original hopper any shells that may be thrown out by the tilting bridge O<sup>2</sup>. The shells are first thrown promiscuously into a hopper, Q<sup>2</sup>. This hopper is reduced to a long narrow shallow trough, R<sup>2</sup>, scarcely more than the diameter of a shell. In the bottom of this trough is a belt, S<sup>2</sup>, of roughened surface, or having cleats distributed along it in order the more readily to draw out the shells. The trough being narrow, but one shell at a time can be taken by the belt, and that must go lengthwise. The trough is shallow at the upper part in order that should there be more than one layer of shells the riders will be forced to roll off, and, falling into the trough T<sup>2</sup>, are carried back to the hopper Q<sup>2</sup>. To prevent riders, it is desirable to place the hopper on an incline, so that they will tend to fall back. This may be assisted by placing a feather or small broom in the trough, so as to keep the riders brushed back. The shells should all go butts foremost. To turn those that go open end foremost, the same sort of tilting device is provided as in my former patent, and here shown at U<sup>2</sup>. Should any fail to turn and continue on open end forward, the hook N<sup>2</sup> will



catch in the open end and arrest the shell. To better expose the open end to the hook, the bridge O<sup>2</sup> is elevated somewhat above the cage M<sup>2</sup>, thus permitting the shell that has passed to drop down out of the way. When the shells go solid end foremost, the hook is pushed up out of the way and rides on top of the shells. The bridge O<sup>2</sup> hangs on a pivot, and has an adjustable balance, W<sup>2</sup>, which is so adjusted that when three or four shells get onto the bridge at once the bridge tilts, spilling the shells into the trough T<sup>2</sup>, to be carried back to the hopper Q<sup>2</sup> by the returning-belt P<sup>2</sup>. This extra accumulation of shells occurs when the cage M<sup>2</sup> is full, or when the hook N<sup>2</sup> arrests a shell. No accumulation of shells must be allowed at the point U<sup>2</sup>, else the dropping of shells will be prevented. The cage M<sup>2</sup> curves downward from the bridge and descends perpendicularly onto the table K<sup>2</sup>, depositing the shell through the opening O<sup>2</sup> into the shell-placer. The pulley X<sup>2</sup>, Fig. 20, shows the cross-belt necessary to actuate the returning-belt P<sup>2</sup> as driven by the pulley carrying the feed-belt S<sup>2</sup>. An enlarged cross-section of the bridge O<sup>2</sup> is shown in Fig. 21, as well as the adjustable balance W<sup>2</sup>, pivot Y<sup>2</sup>, and the relation of trough T<sup>2</sup> for catching tilted shells. An enlarged end view of cage M<sup>2</sup>, the hook N<sup>2</sup>, and arrangement of the four wires Z<sup>2</sup> is shown in Figs. 22 and 23.

The shells having been brought to the table, it is necessary to describe the shell-placer. A side sectional view of the placer is shown in Fig. 24. The shells are fed butts downward into the pocket of the block A<sup>3</sup>, which, by means of suitable bearings, has a sliding-horizontal movement back and forth like a shuttle. The pocket is open at top and bottom, depending on the bearing B<sup>3</sup> to close the aperture below. The depth and width of the pocket are such as that it will accommodate a single shell at a time. When the shell has dropped into it, the block A<sup>3</sup> is moved forward until the pocket is directly under the shell-case M<sup>3</sup> and over the piston C<sup>3</sup>. This piston starts to move at the same time that block A<sup>3</sup> does, and comes against the shell just as it gets over it, and, continuing upward, shoves the shell through the opening N<sup>3</sup> into the shell-case M<sup>3</sup>. The piston and block are then returned to their former positions ready to repeat the operation. They are actuated in common by the double blades D<sup>3</sup>. The piston is directly attached, as at E<sup>3</sup>, but the block is connected by means of a pin or roller, F<sup>3</sup>, playing in the cam-slot G<sup>3</sup>. As the blades D<sup>3</sup> move upward they carry the piston the entire length of their movement, which is regulated by the distance necessary for the piston to do its work. The upper slanting portion (which may be straight or ogee) of the slot G<sup>3</sup> throws the block forward into position, where the lower and perpendicular portion of the slot holds it while the piston is carried up through it and returned. The blades D<sup>3</sup> are operated by the levers H<sup>3</sup>, (two in number, to allow the

cage M to pass between,) connected by links and arm with the head-block Y<sup>3</sup> on the central shaft, F. When the block A<sup>3</sup> is moved forward, the bearing surface P<sup>3</sup> at the top of same becomes a cut-off for closing the cage M<sup>3</sup>, thus preventing the dropping of shells until the pocket, emptied, returns. The placer, with the relation of the parts as just described, is shown in front view, Fig. 25. The placer, as it appears below the table, with the bearings J<sup>3</sup> of the blades D<sup>3</sup>, is shown in side view, Fig. 26. These blades also have bearings cut in the table through which they pass. The opening O<sup>3</sup> in the table, with the arrangement of the wire cage about it, is shown in plan, Fig. 27. N<sup>3</sup>, Fig. 28, is the opening through which the shell is shoved up into the case M<sup>3</sup>, the spring-catches K<sup>3</sup> holding the shell until the case is moved forward.

I now come to the filling apparatus.

The main features of the powder and shot filling devices are alike. The hopper L<sup>3</sup>, Fig. 29, containing the powder, (or shot,) is circular in form. On the upper end of the powder-hopper is cut a thread, M<sup>3</sup>, for screwing on a tube or pipe to extend up through the floor above and near the roof, where an opening is provided, through which the powder may expend its force in case of an explosion. A lever, N<sup>3</sup>, operates the feed and is connected with the head-block Y<sup>3</sup>. This lever may be actuated directly, as here shown, or by means of an ogee slot, as described in my former patent.

O<sup>3</sup> is a ratchet-wheel for operating the feed, and may have direct connection with lever N<sup>3</sup> or by means of an intermediate lever, P<sup>3</sup>. A cut-off blade, Q<sup>3</sup>, prevents discharge when not desired, the movement being in and out. The shell-case M<sup>3</sup> receives the shell. The hopper L<sup>3</sup> is bolted to the base R<sup>3</sup>, which in turn is bolted to the stationary table K<sup>3</sup>. This is not only a base for the hopper, but contains the feed apparatus, now about to be described.

The feed-wheel S<sup>3</sup>, Fig. 30, contains openings T<sup>3</sup>, four or more in number, for receiving powder and shot and delivering them into the shell, one opening being brought over the shell with each movement of central shaft. These are graduated by means of the slides U<sup>3</sup>, which bend down into the cavities and enlarge or diminish them, as shown in previous Letters Patent, or they may be the entire thickness of the wheel. The feed-wheel S<sup>3</sup> has a horizontal movement and is operated by the ratchet O<sup>3</sup> by means of beveled gearing V<sup>3</sup>.

W<sup>3</sup> is a wheel lying on top of feed-wheel S<sup>3</sup>, having cam-slots for regulating the slides U<sup>3</sup>. This regulating-wheel has a stem extending down through the hollow shaft of S<sup>3</sup> and attached to the gage-wheel X<sup>3</sup>, which has scale-marks indicating the various-sized loads, and which when set is held by the thumb-screw Y<sup>3</sup>, bearing against bevel-wheel V<sup>3</sup>.

Z<sup>3</sup> is a sloping bottom cast in hopper L<sup>3</sup> to guide the powder or shot down to the feed-

opening T<sup>3</sup>, and cause the hopper to clean itself; also to cover over and protect the gage-wheel W<sup>3</sup>.

A<sup>4</sup> is a flange cast above Z<sup>3</sup>, sloping toward it and extending to within, say, one-half inch of it. This is especially intended for the shot-hopper to keep the great weight off the feed-wheel S<sup>3</sup>. Fig. 31 is a side sectional view. I have here better shown the sloping bottom Z<sup>3</sup> and the flange A<sup>4</sup>. I have also the location and relation of the cut-off Q<sup>3</sup>. It will be seen that it slides just underneath the feed-wheel S<sup>3</sup> and closes or opens at the bottom the feed-holes T<sup>3</sup>, as may be desired.

B<sup>4</sup> is an opening in the base R<sup>3</sup>, just over where the shell-case M' stands. Through this opening the powder or shot is delivered into the shell as each feed-opening T<sup>3</sup> or feed-wheel S<sup>3</sup> comes over it.

In Fig. 32 I have a top view looking down into hopper L<sup>3</sup>; Z<sup>3</sup>, sloping bottom; S<sup>3</sup>, feed-wheel; T<sup>3</sup>, feed-opening; U<sup>3</sup>, gage slide. Z<sup>3</sup> is so shaped that while one of the feed openings T<sup>3</sup> is delivering the others are being filled and packed, thus always insuring a full and accurate measure.

In Fig. 33 I have a top view with the hopper L<sup>3</sup> removed, leaving the base R<sup>3</sup>, with its embedded parts, exposed; S<sup>3</sup>, feed-wheel with feed-openings T<sup>3</sup> and gage-slide U<sup>3</sup>. There is shown more clearly the gage-wheel W<sup>3</sup>, with cam-slots C<sup>4</sup>, taking hold of pins D<sup>4</sup> in gage-slides U<sup>3</sup>. It is evident that as the gage-wheel is turned one way or the other the slides are moved in or out, thus tending to close or enlarge the feed-openings.

E<sup>4</sup> shows the opening down into the shell underneath; Q<sup>3</sup>, top view of the cut-off and its location.

Fig. 34 presents side view of the wad cutter and placer. Three are used on the machine—two for pasteboard and one for felt—the three being essentially the same device. This wad cutter and placer consists of a tubular cutter, F<sup>4</sup>, for cutting the wad, and an interior solid rammer, G<sup>4</sup>, for carrying the wad when cut down into the shell and ramming it home, said rammer moving back and forth inside the cutter, the cutter cutting against a hard bell-metal die. There are also feed-rollers H<sup>4</sup> for feeding the wad-strips I<sup>4</sup>, operated by ratchet J<sup>4</sup> through the intervention of bell-crank lever K<sup>4</sup>, which in turn is operated by the toothed flange G<sup>2</sup> on the rotating table L<sup>4</sup>, all of which is substantially as set forth in Letters Patent No. 360,043, Figs. 26, 27, and 28, page 5. There is no change in the principles there set forth. The only change here made is in the method of operating the cutter and rammer, with the addition of a device for detecting the accuracy of the loading, all of which I will now proceed to describe.

The rammer G<sup>4</sup> is operated directly by the arm L<sup>4</sup>, attached to the head-block Y<sup>4</sup>. The cutter F<sup>4</sup> is operated by the arm L<sup>4</sup> through the bell-crank levers M<sup>4</sup>, two in number, one

on either side of the arm. These have their pivot in the standard at N<sup>4</sup>, and are operated by a pin in the arm playing in slots, as at O<sup>4</sup>. It is necessary to carry the cutter down through the wad-strip I<sup>4</sup>, cutting the wad, then to hold it (the cutter being too large to enter the shell) while the rammer, continuing on, places the wad and returns within the cutter, when both ascend together, as described in Letters Patent above named. This action of the cutter is produced by means of a cam-slot, P<sup>4</sup>, in which plays a pin or roller, Q<sup>4</sup>, attached to the head of the cutter F<sup>4</sup>. This slot is a cam, say, for one-third of its length, with a slope graduated so as to move the cutter downward the proper distance. The rest of the slot conforms to the center N<sup>4</sup>, so holding the cutter where the cam left it till the rammer continues on, completes its work, and returns, when the cam portion again operates to carry the cutter up along with the rammer, the rammer having the continuous movement of the arm L<sup>4</sup>, to which it is attached. This device greatly simplifies the compound movement of cutter and rammer as related to each other and gives increased power of leverage for operating the cutter.

It is important to know whether all the wads and the proper amount of powder and shot have gone into the shell and gone in correctly. To this end a tell-tale, R<sup>4</sup>, is provided and placed on one or more of the wad cutters and placers. It consists of a bell to be struck whenever there is an inaccuracy in the load, calling the attention of the operator to the fact. On the rammer G<sup>4</sup> is a collar, S<sup>4</sup>. As the rammer descends this collar may be made at any desired point to strike the lever T<sup>4</sup>, which has on its outer end a clapper, causing it to fly up and strike the bell; or the lever T<sup>4</sup> may be made to touch a button, setting off an electric bell. The lever T<sup>4</sup> is pivoted to an arm which extends back and finds bearings U<sup>4</sup>. This arm is made adjustable up or down by screw V<sup>4</sup>. The manner of operating is this: Ascertain exactly where rammer G<sup>4</sup> is to go for a given load, the filling being properly done; then set the lever T<sup>4</sup> by means of the screw V<sup>4</sup> exactly to that point as related to the collar S<sup>4</sup>. Now, if the powder or shot is short in the slightest degree, or if one of the wads is absent or tilted on edge, the rammer will descend farther, and so the lever T<sup>4</sup> will be struck by the collar S<sup>4</sup>, and the bell will sound the alarm.

Fig. 35 is a side sectional view, showing the cutter F<sup>4</sup>, with rammer G<sup>4</sup> inside, all as about to descend on the wad-strip I<sup>4</sup>. Here is seen the manner in which the rammer G<sup>4</sup> is attached to the arm L<sup>4</sup> and operated. X<sup>4</sup> is a head cast on the outer end of arm L<sup>4</sup>, which contains a coil-spring, Z<sup>4</sup>, and serves as a socket for the upper portion of the rammer G<sup>4</sup>, which passes through it. Y<sup>4</sup> is a shoulder on the rammer. This serves to prevent the rammer from dropping out of the socket. At the same time it furnishes a bearing-surface for the spring

Z<sup>4</sup>. The spring is regulated in its tension by the nut A<sup>5</sup>. This nut is hollow and furnishes a bearing for the upper part of the rammer. It will thus be seen that the pressure on the load can exactly be regulated by means of the nut A<sup>5</sup> and spring Z<sup>4</sup>; also that the spring when set will always be compressed to a given point for a given load. If, therefore, the load is short in any way, the spring will force the rammer to go farther down in the shell, so causing the collar S<sup>1</sup> to strike the bell, as before described. To cause the arm L<sup>4</sup> to move perfectly true and steady, a bearing, as B<sup>5</sup>, is given it in the standard. Like bearings are also given the head-block of the cutter F<sup>4</sup> at C<sup>5</sup>. These may be more clearly seen in Figs. 36 and 37, which are top sectional views. To avoid slipping on the wad-strip and to compel the rollers H<sup>4</sup> to move together, they are geared together by cog-wheels D<sup>5</sup>, Fig. 36, which have teeth sufficiently long to admit of the rollers being spread without affecting the action of the gearing.

Fig. 38 is a top view of the arm L<sup>4</sup>, showing opening E<sup>5</sup> for the wad-strip to pass through. Here also I have top views of the two levers M<sup>4</sup>, for operating the cutter, one on each side of the arm L<sup>4</sup>.

Fig. 39 presents a side view of the indenter for making the indentations for holding the last wad. The tripod F<sup>5</sup>, attached to the rammer G<sup>5</sup>, for carrying the indenters H<sup>5</sup>, with the bent bars I<sup>5</sup>, for throwing same in and out, the depressions in the bottom of the rammer conforming to the indenting points, the spring J<sup>5</sup> in the table on which the shell rests during operation, all are substantially as described in Letters Patent No. 360,043, Figs. 29 to 32, pages 5, 6. The improvement consists in the device for operating the indenting-points and tripod for carrying same. The bent bars I<sup>5</sup>, for throwing the indenters in and out, are attached directly to the arm K<sup>5</sup> at L<sup>5</sup>, and are continuous with its movement. The difficult thing to do is to move the rammer G<sup>5</sup>, carrying the tripod F<sup>5</sup>, down a certain distance—namely, to the point where the load is properly compressed—and there hold it steady while the indenting-points are being thrown in and withdrawn. To accomplish this, two cam-slotted arms, M<sup>5</sup>, are bolted to the arm K<sup>5</sup>, one on either side. The slots N<sup>5</sup> in these arms are horizontal a part of the way and finally curve up into a perpendicular line. In these slots play pins or rollers O<sup>5</sup>, attached to levers P<sup>5</sup>, which also have curved slots Q<sup>5</sup>, which, by means of pins playing therein—these pins being solidly attached to the flattened head R<sup>5</sup> of the rammer G<sup>5</sup>—operate the rammer and tripod. The rammer-head R<sup>5</sup> has bearings in the arm-head S<sup>5</sup> of the arm K<sup>5</sup>, there being slots in arm-head through which the pins pass that work in slots Q<sup>5</sup> in lever P<sup>5</sup>, said slots being of sufficient length to accommodate the movement of the rammer G<sup>5</sup>. (See T<sup>5</sup>, Fig. 40.) It will be seen that as the arm K<sup>5</sup> descends it carries with it the levers P<sup>5</sup>, and so the rammer G<sup>5</sup>, with tripod F<sup>5</sup>, un-

til the pins O<sup>5</sup> reach the perpendicular portion of the slots N<sup>5</sup>, (being the point at which it is desirable to compress the load,) where the levers P<sup>5</sup>, with rammer and tripod, are held stationary, while the arm K<sup>5</sup> continues on, thrusting the indenters H<sup>5</sup> in and withdrawing them by means of the bent bars I<sup>5</sup>, when the pins O<sup>5</sup>, reaching the curved and horizontal portion of the slots N<sup>5</sup>, all are carried up together to their original position. It is the intention to use the spring J<sup>5</sup> only in case of an accidental overcharge of powder or shot, being strong enough not to give with an ordinary load and pressure. To accommodate the various-sized loads, a set-screw, U<sup>5</sup>, is used to raise and lower the slotted arms M<sup>5</sup>. There is also for the same purpose a regulating-screw, V<sup>5</sup>, and set-screw W<sup>5</sup>, which takes hold of block X<sup>5</sup>, which supports the pivots of levers P<sup>5</sup>.

Fig. 41 is a top view showing arrangement of slotted arms M<sup>5</sup> and relation to levers P<sup>5</sup>. It is shown here by dotted lines how the pin Y<sup>5</sup>, passing through the flattened rammer-head R<sup>5</sup>, takes hold of the levers P<sup>5</sup>. I have here also shown the bearings Z<sup>5</sup> in the arm K<sup>5</sup> for the rammer-head R<sup>5</sup>.

Fig. 42 gives a different-shaped indenter from that shown in previous Letters Patent, which was designed to cut simply the bottom of the indentation and shove it in over the wad. The object of this new indenter is to cut the top as well as the bottom of the indentation, so that the indentation may be shoved in at the top as well as the bottom—a form thought to be desirable in some instances. To accomplish this, the knife-like edges A<sup>6</sup> are provided at top and bottom of indenter. The edge B<sup>6</sup> in this case is perpendicular, instead of slanting, as formerly represented.

After the indenter has completed its work there is nothing to be done but to print the designation of the load and extract the cartridge from the shell-case. This is accomplished by the extractor, Fig. 43, a side view of which is here given. The cartridge is shoved out of the case M<sup>1</sup> through the hole P<sup>1</sup> in the stationary table K<sup>1</sup> by means of the extracting-rod C<sup>6</sup>, which is caused to move downward with the central shaft, E<sup>1</sup>. The diameter of the extracting-rod is such as to prevent its striking and crushing the indentations over the wad. It has a bearing for its lower end through the projecting support D<sup>6</sup>. The upper end is fastened to the head-block E<sup>6</sup>, which has bearings in the frame F<sup>1</sup>. It is necessary to give the extracting-rod a longer movement than is afforded by the shaft E<sup>1</sup>. This is accomplished by the intervention of the lever G<sup>6</sup>, operated by the arm H<sup>6</sup>. As shown in previous Letters Patent, the printing on the wad, the designation of the load, is done in the act of extracting the cartridge by means of an adjustable die, I<sup>6</sup>, on the end of the extracting-rod. The only change here is in the manner of inking the die. This is done by means of the inking-roller J<sup>6</sup>, made of felt or other absorbent capable of holding a considerable

quantity of ink, passing over the die as the extracting-rod descends. This is effected by the arms K<sup>5</sup>, supporting the roller being so pivoted, as at L<sup>5</sup>, that the roller is pushed aside and so rolled across the surface of the die by the descent of the extracting-rod. To throw the roller back when the extracting-rod returns and to hold it firmly against the die, a spring, as M<sup>5</sup>, is provided, which bends around the pivot-post L<sup>5</sup> and hooks into the arms K<sup>5</sup>, giving them a tendency to fly up. In order to prevent the roller J<sup>5</sup> from bearing against the extracting-rod while it continues to descend, thus keeping it daubed with ink, a slight projection or pin, N<sup>5</sup>, is provided to hold the roller off.

Fig. 44 gives top view showing the supporting arms or frame F<sup>5</sup> and the bearings in same of head-block E<sup>5</sup> of extracting-rod; Fig. 45, top view of inking roller J<sup>5</sup>, with supporting-arms K<sup>5</sup> and actuating-springs M<sup>5</sup>.

Having thus described my invention, what I claim, and desire to secure by Letters Patent, is—

1. In a cartridge-loading machine, the combination, with the actuating mechanism and a central shaft actuated by a cam-wheel provided with eccentric guideways and with in-and-out trends about a quadrant apart, of a roller for operating said central shaft and a roller for operating a horizontal slide, each engaging such eccentric way, and said slide being connected with and operating a lever, I, in a reciprocating manner by means of rollers at the outer end of said slide playing in an ogee slot or slots in said lever, the other end of the lever being connected to mechanism for rotating a shell-supporting table, as and for the purpose set forth.

2. In a cartridge-loading machine, the combination, with a horizontal slide, H, having rollers P connected thereto, of the adjustable lever I, having slotted blades engaging the rollers, said slots being ogee in shape and acting as cams to impart motion to the lever I through the intervention of the rollers, and intermediate connections between the lever I and the revolving shell-carrying table, as and for the purpose set forth.

3. In a cartridge-loading machine, the combination, with the central shaft and its actuating mechanism, of a hollow shaft and rotating table secured thereto, a lug-plate having lugs corresponding to the shell-cases, said lug-plate being connected with the table by means of a hollow shaft, as and for the purpose set forth.

4. In a cartridge-loading machine, the combination, with the central and hollow shafts and their actuating mechanism, a rotating shell-supporting table, and a lug-plate connected thereto, of a lever pivoted to a hollow shaft having the extension C', for operating the catch A', and the spring-catch X, for engaging successively the lugs on the lug-plate and pushing them till caught and held by the catches Z and A', as and for the purpose set forth.

5. The combination, with the rotating shell-

carrying table of a cartridge-machine, of the lug-plate connected thereto and having lugs U, a lever, W, pivoted on the shaft of the lug-plate, having an arm, C', extending therefrom and connected with suitable operating mechanism, and two spring-catches, A' Z, carried by the frame of the machine and embracing the lugs in succession, one catch acting horizontally and the other perpendicularly, so as to stop the movement of the lug-plate and prevent its rebound, as and for the purpose set forth.

6. In a cartridge-loading machine, the combination, with the rotating table and lug-plate connected thereto, of an air cushion or chamber provided with a piston engaged and actuated by the lugs successively, whereby the jar of the lug-plate and rotating table is prevented, as set forth.

7. The combination, with a rotating table, its lug-plate, and actuating mechanism, of a catch, A', provided with a piston moving in and out of the air-chamber, the lugs on the lug-plate, when the latter is rotated, alternately coming into contact with the catch, said cylinder having a slot to accommodate the sliding movement of the piston and hold the catch in position, as and for the purpose set forth.

8. In a cartridge-loading machine, the combination, with the driving mechanism, of a cam-wheel having variations from its center arranged in quarters, and intermediate connection between such cam-wheel and a rotary shell-carrying table, and the reciprocating shaft which supports the loading implements, whereby these parts are alternately operated, as set forth.

9. In a cartridge-loading machine, the combination, with the driving mechanism, of a cam-wheel engaging rollers actuating a central shaft and horizontal slide, said cam-wheel having a central variation arranged in quarters, the rollers engaging said variations at right angles and alternately, one roller giving the central shaft a vertical movement, the other giving the slide a horizontal movement, and such slide being in operative connection with the rotary shell-carrying table, as and for the purpose set forth.

10. In a cartridge-loading machine, the combination, with the central shaft, a hollow shaft surrounding the same, and slide H, having rollers P connected thereto and engaging a rotary cam on the driving-shaft, of the adjustable lever I, having slotted blades engaging the rollers, said slots acting as cams to impart motion to the lever I through the intervention of the rollers and by intermediate connection to a rotary shell-supporting table carried by the hollow shaft, substantially as and for the purpose set forth.

11. In a cartridge-loading machine, a shell-feeder consisting of a hopper gradually diminishing in width and depth from the receiving to the discharge end, a conveying and return belt, a wire cage for conducting the shells

to the shell-placer, a hook for arresting said shells entering said cage wrong end foremost, and a tilting bridge for throwing out arrested shells or excess of shells.

5 12. In a shell-feeding device, the combination, with a cage leading to the shell-placer, of a tilting pivoted bridge provided with a balance-weight so adjusted that when more than one shell is on said bridge it will automatically tilt and displace the excess of shells.

10 13. In a cartridge-loading machine, a shell-placer consisting of a piston and shell-holding block, said block sliding horizontally in bearings beneath the shell-holder of the rotating table, the upper bearing of the block forming a cut-off to the shell-feeder when the block is moved beneath the shell-holder, as and for the purpose set forth.

15 14. In a shell-placing device, the combination, with the actuating mechanism, of a hollow block to receive the shell from the feeder, a piston for forcing the shell into the case, said block and piston being actuated by slotted double blades  $D^2$  on the lever attachment to the central shaft, the block being connected thereto by a roller moving in the cam-slot, the roller in the upper portion of the slot moving the block forward into position, and in the lower portion of the slot holding the block while the piston passes through it, as and for the purpose set forth.

20 15. In a cartridge-loading machine, the combination, with a powder or shot hopper, of a feed wheel operated by a ratchet, said feed-wheel containing four or more openings to the shell, said openings being graduated by slides radiating from the center of the feed-wheel and regulated by a cam-slotted wheel conforming to said center, and having a stem reaching downward through the bottom of the hopper, as and for the purpose set forth.

25 16. In a cartridge loading machine, the combination, with a support for the wad-strip, of a wad cutter and placer consisting of a tubular cutter and an interior rammer, the rammer

being actuated directly by the arm  $L^1$ , extending from the head-block of the central shaft, and the cutter being actuated by the same arm through the intervention of cam-slotted levers  $M^1$ , by which said cutter is moved to a certain distance and held in position for the return of the rammer, as and for the purpose set forth.

30 17. The combination, with the shell-supporting mechanism, of a shell-indenting device consisting of the rammer  $G^2$ , with flattened head  $R^2$ , the tripod  $F^2$ , for carrying the indenters, the bars  $I^2$ , for throwing the indenters in and out, the arm  $K^2$ , with bearings  $S^2$ , the cam-slotted arms  $M^2$ , the levers  $P^2$ , and the indenting-points with knife-like edges or projections  $A^2$  at the end, as and for the purpose set forth.

35 18. In a cartridge-loading machine, the combination, with the support for the wad-strip and feed mechanism therefor, of a wad cutter and placer consisting of a tubular cutter and an interior rammer, the rammer being actuated directly by the arm  $L^1$ , extending from the head-block of the central shaft, and the cutter being actuated by the same arm through the intervention of the cam-slotted levers  $M^1$ , by which said cutter is moved a certain distance and held in position for the return of the rammer, as and for the purpose set forth.

40 19. In a cartridge-loading machine, the combination, with the shell-holder and a reciprocating plunger for ejecting the loaded shell, said plunger carrying a wad-marker at its lower end, of a spring-pressed vibrating lever pivoted to the frame which supports the plunger and carrying an ink-roller in position to engage and be pressed aside by the plunger-head, as set forth.

In testimony whereof I affix my signature in presence of two witnesses.

G. MOORE PETERS.

Witnesses:

W. K. MCKIBBEN,

F. NEWTON SHAFFER.