

(No Model.)

W. J. NOBLE.
COFFIN FASTENER.

No. 421,106.

Patented Feb. 11, 1890.

Fig. 1.

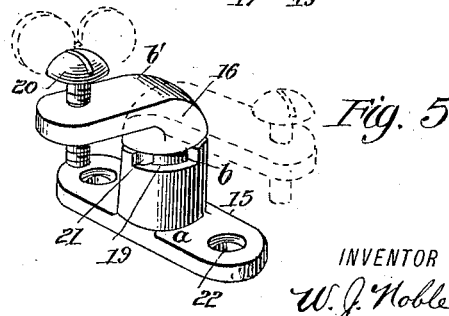
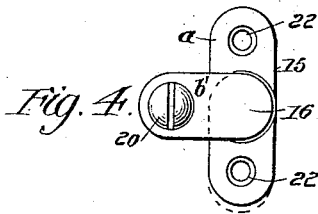
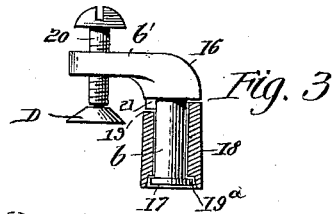
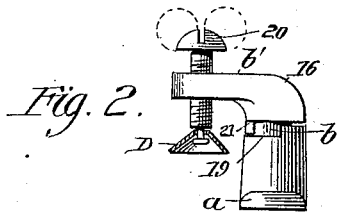
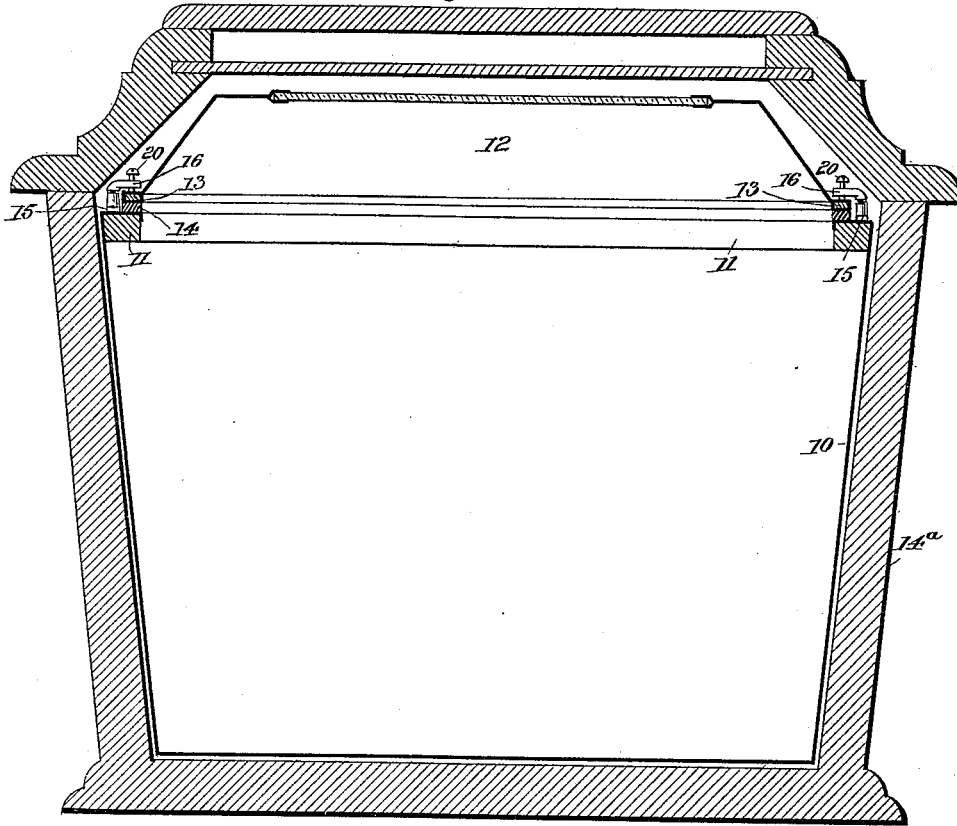

WITNESSES:

J. H. Clark.
C. Sedgwick

INVENTOR

W. J. Noble

BY

Munn & Co.

ATTORNEY

UNITED STATES PATENT OFFICE.

WILLIAM J. NOBLE, OF NEW YORK, N. Y.

COFFIN-FASTENER.

SPECIFICATION forming part of Letters Patent No. 421,106, dated February 11, 1890.

Application filed November 11, 1889. Serial No. 329,901. (No model.)

To all whom it may concern:

Be it known that I, WILLIAM J. NOBLE, of the city, county, and State of New York, have invented a new and Improved Fastening Device for Burial-Caskets, of which the following is a full, clear, and exact description.

My invention relates to an improvement in fastening devices for burial-caskets, especially adapted for use in connection with metallic caskets, and has for its object to provide a burial-case with a simple and economical fastening device which can be easily and quickly manipulated to firmly secure the lid to the top of the case, and which, while the said lid is firmly secured, will not take up an undue amount of space or necessitate any enlarging of the outer casket.

The invention consists in the novel construction and combination of the several parts, as will be hereinafter more fully set forth, and pointed out in the claim.

Reference is to be had to the accompanying drawings, forming a part of this specification, in which similar figures of reference indicate corresponding parts in all the views.

Figure 1 is a vertical transverse section through the metallic casket having my improvement applied, and also through the outer casket. Fig. 2 is an end view of the device detached. Fig. 3 is a central vertical section through the socket, the revoluble arm being in elevation. Fig. 4 is a plan view, and Fig. 5 is a perspective view, of the device, illustrating the device in its true position.

In carrying out the invention the body 10 of the inner or metallic casket is shown provided at the top with an interior filling piece or frame 11, extending around the sides and ends, over which the metal of the body is carried and secured in any approved manner. The body 10 of the casket is adapted to receive a suitable cover 12, having a marginal flange 13 of less width than the filling-piece 11 of the body. When the cover is placed upon the body, a rubber packing or gasket 14 is made to intervene the upper edge of the body and the flange of the cover, as best shown in Fig. 1.

The metallic casket is illustrated as inclosed within a case 14^a, and by reference to the said figure it will be readily observed that the fastening device, to be hereinafter described, does

not interfere in the slightest with the fitting of the outer case over the inner or metallic casket.

The fastening device comprises, primarily, a base or body 15 and a revoluble arm 16. The base or body 15 consists of a base-plate α , having a central rabbeted bore 17 and a collar 18 surrounding the said opening, extending vertically upward to form a socket, as best illustrated in Fig. 3, in which the rabbet of the opening 17 is clearly shown. In the upper edge of the socket 18 a segmental recess 19 is produced, for a purpose hereinafter stated. The revoluble arm 16 is angled or in the form of an elbow, as best illustrated in Fig. 3. The vertical member b is cylindrical and of sufficient diameter to turn freely in the socket 18, being provided at the lower extremity with an attached washer 19^a, forming a flange fitting in the rabbeted opening 17 of the said socket, whereby the arm is prevented from being withdrawn from the said socket, yet is capable of being freely revolved therein. The outer extremity of the horizontal member b' of the arm 16 is preferably flattened and provided with a threaded aperture capable of receiving a screw 20, which screw may be in the form of a set-screw, as illustrated in Figs. 3 and 4, or in the form of a thumb-screw, as shown in dotted lines in Figs. 2 and 5. The horizontal member b' of the arm is enlarged at its intersection with the vertical member, and from the overhanging portion of the said horizontal section of the arm 16 a lug or stop 21 is downwardly projected within the socket-recess 19, as best shown in Figs. 2, 3, and 5. The lug or stop 21 is so disposed upon the arm and the recess 19 is so located upon the socket that when the stop or lug 21 is in contact with one wall of the socket-recess the horizontal member of the arm will be at a right angle to the base-plate, as illustrated in Fig. 3 and in positive lines, Fig. 5. This is the locked position of the device. When the said lug or stop contacts with the opposite end wall of the socket-recess 19, the horizontal member of the arm is brought to a position over and parallel with the base-plate, as indicated in dotted lines, Fig. 5. This is the unlocked position of the device, and when the device is in this position the cover may be readily removed.

Any desired number of the locking devices are secured to the body of the casket, as illustrated in Fig. 1, and in attaching the device the base-plate is made to rest upon the upper projecting metallic surface of the body over the filling-piece 11 longitudinally of the said filling-piece and is secured rigidly thereto, preferably by passing suitable screws through proper apertures 22, one of which apertures is preferably produced at or near each end of the base-plate.

In locating the base-plate of the device upon the filling-piece 11 one longitudinal edge of the base-plate is preferably placed essentially flush with the outer face of the body of the casket, and the socket-recess 19 is upon the inner side. After the cover has been placed in position upon the body and it is desired to secure the same to place, the arm 16 is carried to its locked position, or at a right angle to the base-plate, as illustrated in Fig. 1, whereupon the outer extremity of the horizontal member of the arm will be brought over the flange of the cover. The set or thumb screw 20 is then screwed downward upon the upper surface of the flange, thereby producing a hermetical seal. To remove the cover from the body, the set or thumb screw is carried upward and the arm thrown to one side, or in a position parallel with the base-plate.

In practice I prefer to swivel to the inner

end of the set-screw a bearing-block D to secure a firmer hold upon the lid to prevent unnecessary marring of the same. I am aware that a button has been employed to secure the lids of the caskets to place, said button being used in connection with a screw which passes through it, the button being forced to and from a bearing with the lid by turning the screw, as the said construction is shown and described in the patents granted to William A. Sparks April 10, 1888, Serial No. 380,704, and to Sparks and Rappleyea March 16, 1886, No. 338,198.

Having thus described my invention, I claim as new and desire to secure by Letters Patent—

A fastening device for burial-caskets, comprising a base-plate, a socket projected upward from the said base-plate having a segmental slot in its upper edge, an angle-arm held to revolve in the socket provided with a lug or stop extending downward within the socket-recess, and a retaining-screw carried by the horizontal member of the said arm and provided at its threaded end with a swivel bearing-block, substantially as shown and described.

WILLIAM J. NOBLE.

Witnesses:

J. F. ACKER, Jr.,
C. SEDGWICK.