

R. W. SCOTT & L. N. D. WILLIAMS.

CIRCULAR RIB KNITTING MACHINE.

No. 421,147.

Patented Feb. 11, 1890.

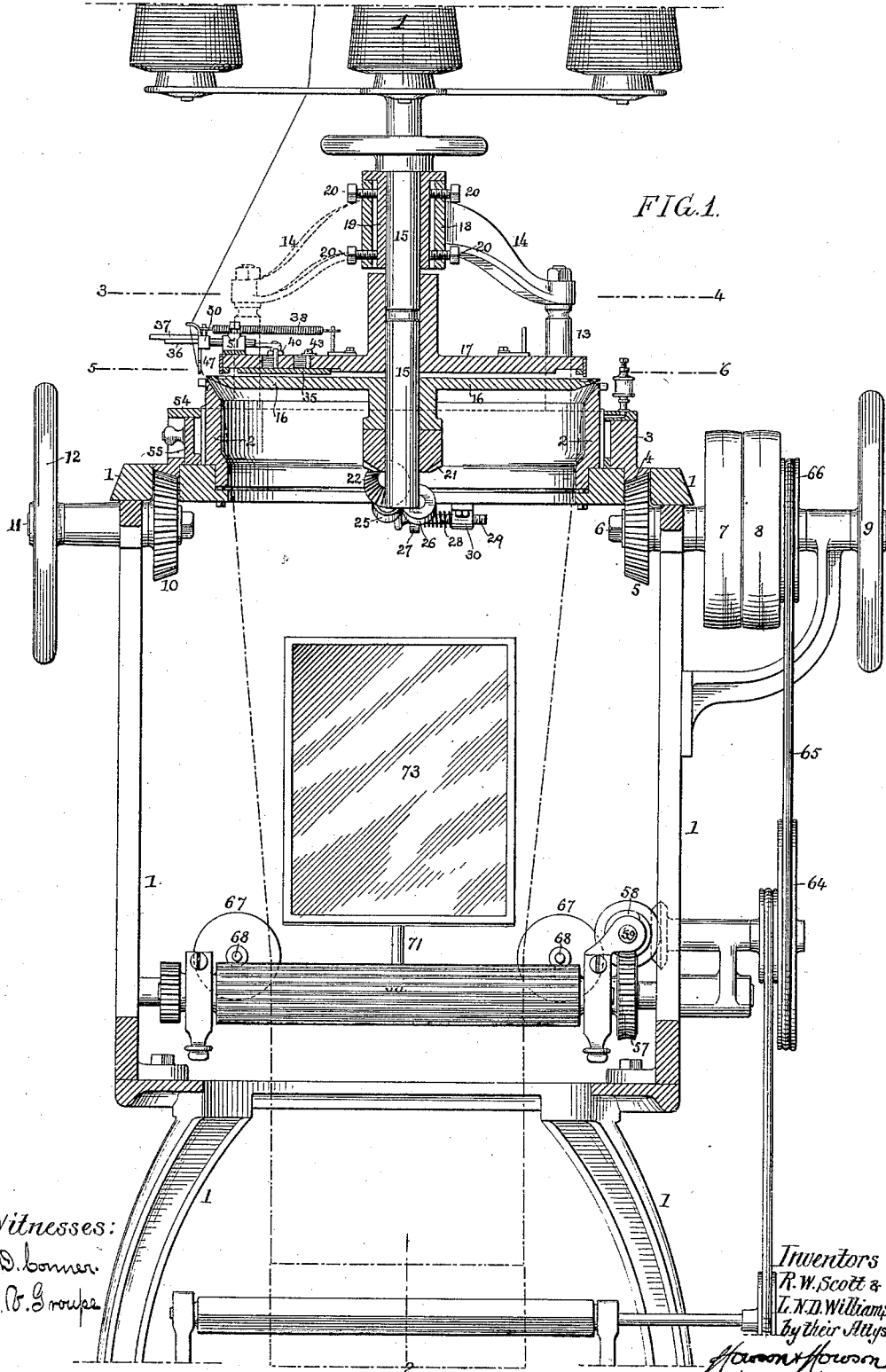

Witnesses:
 W. D. Bonner
 A. B. Grouse

Inventors
 R. W. Scott &
 L. N. D. Williams
 by their Attys
 H. W. Brown

R. W. SCOTT & L. N. D. WILLIAMS.

CIRCULAR RIB KNITTING MACHINE.

No. 421,147.

Patented Feb. 11, 1890.

FIG. 2.

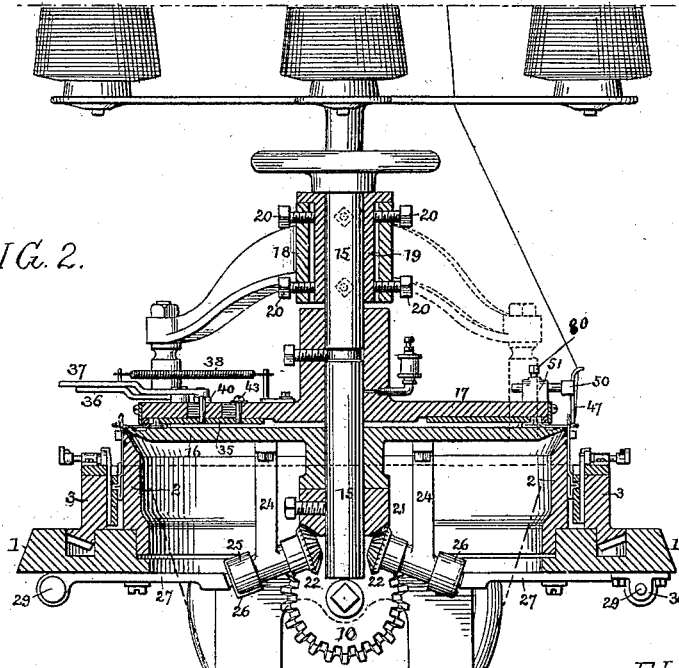

FIG. 6.

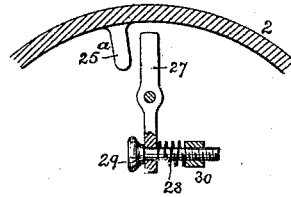
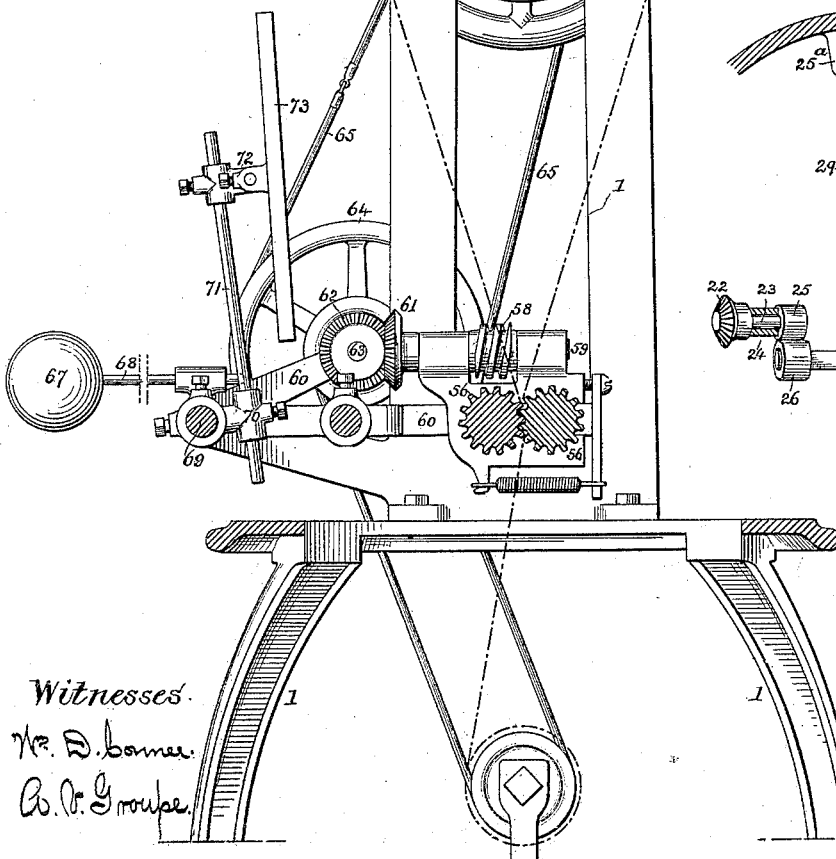
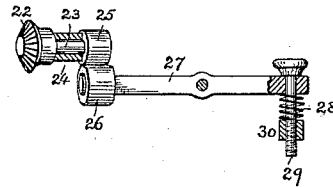

FIG. 5.



Witnesses:
 W. D. Bonner.
 C. V. Grouse.

Inventors:
 R. W. Scott &
 L. N. D. Williams
 by their Attys
 Howson & Howson

(No Model.)

3 Sheets—Sheet 3.

R. W. SCOTT & L. N. D. WILLIAMS.

CIRCULAR RIB KNITTING MACHINE.

No. 421,147.

Patented Feb. 11, 1890.

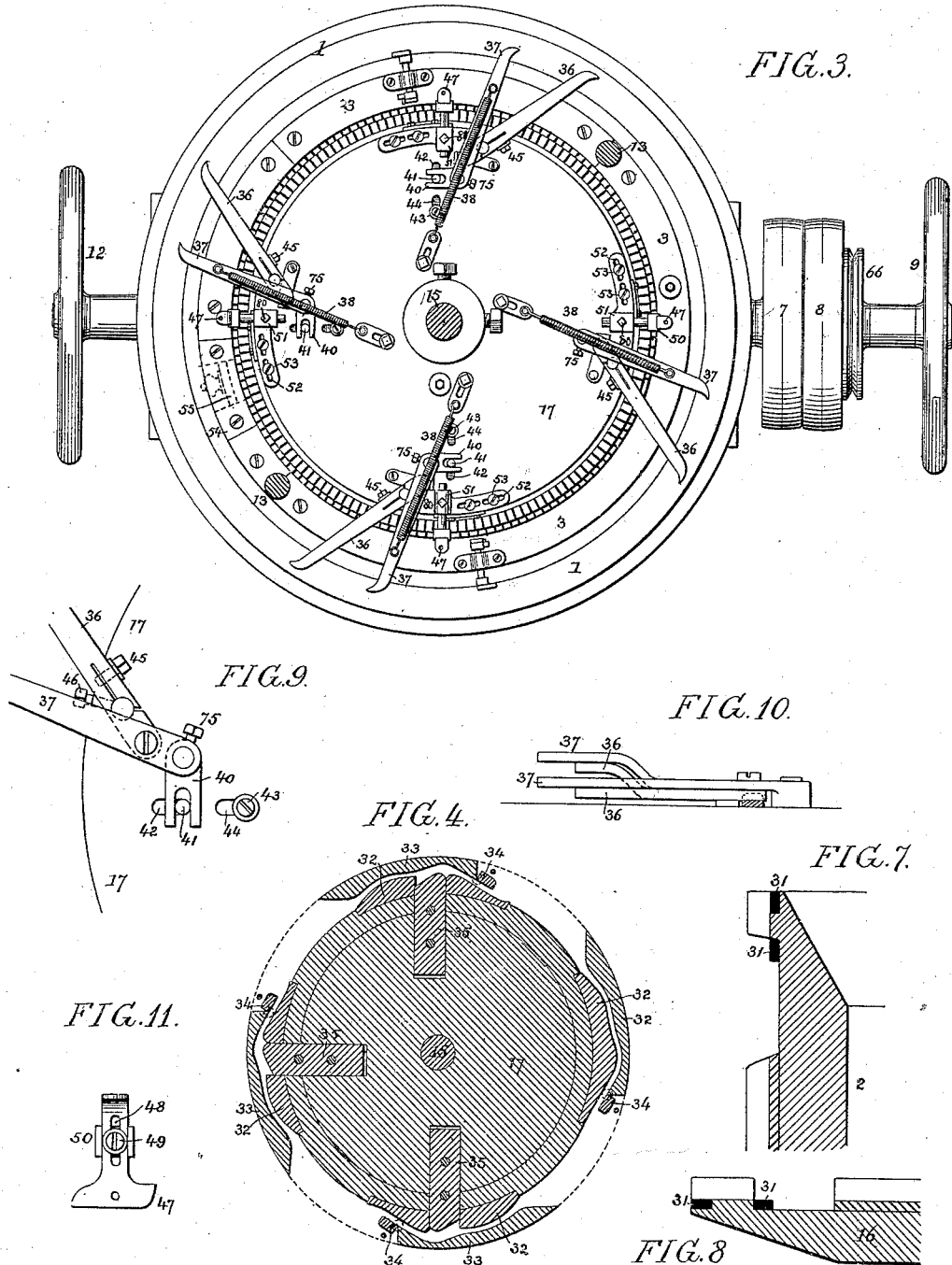

Witnesses:
 William D. Bonner
 C. V. Groupe.

Inventors:
 Robert W. Scott &
 Louis N. D. Williams
 by their Attorneys
 Howson & Howson

UNITED STATES PATENT OFFICE.

ROBERT W. SCOTT AND LOUIS N. D. WILLIAMS, OF PHILADELPHIA,
PENNSYLVANIA.

CIRCULAR-RIB-KNITTING MACHINE.

SPECIFICATION forming part of Letters Patent No. 421,147, dated February 11, 1890.

Application filed July 11, 1889. Serial No. 317,175. (No model.)

To all whom it may concern:

Be it known that we, ROBERT W. SCOTT and LOUIS N. D. WILLIAMS, both citizens of the United States, and residents of Philadelphia, Pennsylvania, have invented certain Improvements in Circular-Rib-Knitting Machines, of which the following is a specification.

Our invention relates to rib-knitting machines in which a needle-cylinder and dial, or their equivalents, are combined with each other, one object of our invention being to so construct such a machine as to insure the absolute truth of the dial in respect to the cylinder and the proper working of the needles of one in respect to those of the other; a further object being to lessen the friction caused by the passage of the fabric between the stops or bearing-dogs of the cylinder and dial; a still further object being to insure a positive, uniform, and steady take-up for the material as it is produced; another object being to provide for the tucking of the needles of the dial on their outward movement, or on both the outward and inward movement; another object being to provide for universal adjustment of the yarn-guide; another object being to permit the ready removal of a needle from the machine when desired; and a still further object being to so construct the cylinder or dial as to prevent excessive wear of the upper or outer edges of said cylinder or dial and of the bottoms or bases of the needle grooves or slots therein. These objects we attain in the manner hereinafter set forth, reference being had to the accompanying drawings, in which—

Figure 1 is a vertical sectional view, partly in elevation, of a knitting-machine constructed in accordance with our invention. Fig. 2 is a transverse section of the same on the line 1 2, Fig. 1. Fig. 3 is an enlarged sectional plan view on the line 3 4, Fig. 1. Fig. 4 is a sectional plan view on the line 5 6, Fig. 1; and Figs. 5 to 11 are detached views illustrating special features of construction or modifications of the invention.

The fixed frame 1 of the machine carries the vertical needle-cylinder 2 and has suitable bearings formed on it for the vertical cam-cylinder 3, which is provided with cams,

as usual, for actuating the needles of the cylinder, and has a bevel-gear 4 for engaging with a bevel-pinion 5 on the driving-shaft 6, adapted to bearings in the fixed frame and having fast and loose pulleys 7 and 8 for receiving a belt from any available counter-shaft, the shaft 6 being also provided with a hand-wheel 9, by which the machine may be operated by hand on the various occasions when such operation is required. The bevel-gear 4 of the cam-cylinder 3 is also in mesh with a bevel-pinion 10 on a short shaft 11, adapted to bearings in the main frame opposite those which carry the shafts 6, this shaft 11 being likewise provided with a hand-wheel 12, whereby the machine may be operated when it is not convenient to operate it by the hand-wheel 9, the provision of this secondary driving-shaft and hand-wheel being of considerable importance in machines of large size, such as are employed for the manufacture of shirts and like articles of underwear, owing to the fact that while engaged in adjusting or making repairs to parts of the machine in certain locations the hand-wheel 9 is practically inaccessible, and a single attendant cannot conveniently attend to the making of such adjustments or repairs, as slight movement of the rotating parts of the machine is frequently required while the repairs are in progress. In our machine, however, one or other of the hand-wheels is readily accessible by the attendant from any point on the machine where adjustment or repair is likely to be required.

The cam-cylinder 3 has the usual columns 13, supporting the arch 14, which carries the central spindle or stem 15, on which the needle-dial 16 is supported, and to which the dial cam-plate 17 is secured so as to turn with the main cam-cylinder, the dial being prevented from turning by engagement with a projecting portion of the needle cylinder or bed, as described hereinafter. Instead of the central spindle 15 being secured directly to the hub 18 of the arch, however, as usual, said spindle is secured to a sleeve 19, which is carried by a number of radially-disposed set-screws 20, equidistantly located around the hub 18, four pairs of these screws being shown

in the present instance, one screw of each pair being adjacent to the top of the hub, and the other screw of each pair being adjacent to the bottom of the hub, so that the two radially-disposed sets of screws are in different vertical planes. By the manipulation of these set-screws the sleeve 19, and consequently the spindle 15 and the needle-dial and its cam-plate can be moved laterally in any direction and to any extent, so that the absolute centering of the dial with respect to the needle-cylinder can be readily effected and the production of a tube uniform in all its parts thus insured. The set-screws may, if the sleeve 19 is circular, take such hold of said sleeve as to insure the rotation of the same with the hub 18; or the sleeve and hub may be of polygonal or other shape, which will insure the turning of one by the other.

It is important, also, that provision for accurate and minute circumferential adjustment of the dial should be provided in a machine of this class in order that the needles of the dial may work properly in the spaces between the needles of the cylinder, so as to prevent accidental contact of the needles of one with those of the other. For this reason we provide means for the delicate adjustment of the bearing lug or dog carried by the cylinder or dial in respect to that carried by the dial and cylinder, and we also provide for a positive feed being imparted to the fabric where it passes between these two bearing-surfaces, so that the friction upon the fabric—such as is caused by the passage of the same between the ordinary rigid bearing-surfaces of the cylinder and dial—is overcome. The construction of parts for the attainment of these objects is shown in Figs. 1, 2, and 5, on reference to which it will be observed that the spindle 15 carries at its lower end a bevel-wheel 21, which serves incidentally as the means of vertically supporting the needle-dial 16. This bevel-wheel 21 meshes with bevel-pinions 22 on short shafts 23, adapted to bearings in brackets 24, depending from the under side of the dial, the outer ends of these shafts having anti-friction rollers 25, which serve as feed-rollers and act in conjunction with rollers 26, carried by the inner arms of levers 27, hung to the under side of the fixed frame 1 of the machine, the outer arm of each lever being acted upon by a spring 28 and an adjusting-screw 29, the threaded stem of the latter being adapted to a threaded opening in a lug 30 on the under side of the frame. The knitted web as it passes downward from the needles of the cylinder and dial is caused to pass between the rollers 25 and 26 in the same manner as it ordinarily passes between the lugs of the cylinder and dial; but as the rollers 25 have a rotating movement imparted to them the downward movement of the web of fabric is not interfered with, but may, on the contrary, be facilitated.

It will be evident that by moving the levers 27, or either of them, pressure may be brought to bear upon the rollers 25, so as to cause a circumferential movement of the dial in respect to the cam-cylinder, and by reason of the employment of the adjusting-screw 29 for effecting the movement of the lever extremely delicate adjustments of the dial in respect to the cylinder are possible, and the correct working of the needles of the dial in respect to those of the cylinder may be thus insured.

It is not absolutely necessary that the rollers 25 should be positively driven, as anti-friction rollers turning on fixed studs projecting from the brackets 24 may in some cases be used with good effect as regards the lessening of the friction upon the descending web of fabric, and so far as regards the provision for effecting delicate adjustment of one bearing in respect to the other our invention may be carried out in connection with rigid bearing-lugs, such as are usually employed, an instance of such construction being shown in Fig. 6, in which the outer arm of a lever 27, hung to the under side of the dial, is caused to engage with a lug 25^a, projecting inward from the needle-cylinder 2, the inner arm of the lever 27 being acted upon by a spring 28 and an adjusting-screw 29, of the same character as that shown in Figs. 1, 2, and 5.

The needle-cylinder 2 and the needle-dial 16 are grooved or slotted, as usual, for the reception and guidance of the shanks of the needles; but as these parts of the machine are usually made of brass or other soft metal they have a tendency to wear, especially at the upper or outer ends, where the heels of the latches at the back of the needle-shanks are being rapidly and continuously moved to and fro over the bases of the slots, and where the fabric is being continuously drawn over the edge of the cylinder or dial. To counteract this tendency, therefore, we recess the upper edge of the cylinder and the outer portion of the dial for the reception of one or more hardened bearing-rings 31, as shown in Figs. 7 and 8, two of such rings being there shown—one at the extreme edge of the cylinder or dial and the other some distance inward therefrom—these rings providing hardened bearing-surfaces for the latch-carrying ends of the needles and serving to prevent wear of the cylinder or dial by the butts of the latches or by the fabric passing over the edge of said cylinder or dial.

The dial cam-plate 17 has needle-projecting cams 32 and needle-retracting cams 33, and at the tail end of each of said retracting-cams 33 is a pivoted toe 34, which, when thrown inward, as shown in Fig. 4, will cause the dial-needles to be retracted to their full extent, so as to cast their stitches, but if moved outward will fail to move the needles inward to their full extent, and will thus allow the needles to retain their old stitches, as well as to

receive new loops, thus forming what is called a "tuck-stitch." Some of the projecting cams 32 also have movable bits 35, which, when occupying their outermost position, cause the needles to be fully extended, so as to slip the stitches carried thereby back of the latches; but when these movable bits are retracted, as shown in Fig. 4, they will fail to project the needles to the full extent, and will permit them to retain their old stitches and receive new loops, thus also forming a tuck-stitch.

The pivot-shanks of the toes 34 are provided with levers 36, the outer arms of which project into the path of suitable adjustable tripping arms or disks common to machines of this class, and such, for instance, as shown in R. W. Scott's patent, No. 368,429, dated August 16, 1887, the inner arms of the levers being connected to other levers 37, also projecting into the path of the tripping arms or disks, so that when the lever 36 is acted upon directly it will be moved in one direction, and when the lever 37 is acted upon the lever 36 will be moved through the medium of said lever 37, but in the opposite direction from the movement directly imparted to it. By contact first of one lever and then of the other lever with the tripping arm or disk, therefore, the toe 34 of the retracting-cam may be moved to the full knitting-point or to the tuck-point, as desired.

The levers 37 are acted upon by springs 38, which, when the lever is in one extreme position, are on one side of the central line of the lever, and when said lever is in the other extreme position are on the opposite side of said central line, so that the springs tend to hold the levers in their extreme positions or to move them to such extreme positions as soon as the spring has passed the central point of the lever in the movement of the latter in one direction or the other. Where the projecting cams 32 have movable bits 35, these bits may be operated by the levers 37, these levers having notched arms 40, engaging with pins 41 projecting from the movable bits of the cams through radial slots 42 in the cam-plate, other pins 43 on the bits projecting through other radial slots 44, and serving to guide and support the rear ends of the movable bits.

In cases where it is desired to operate only the toes 34 of the retracting-cams 33, the levers 37 may not have the arm 40. (See, for instance, the construction shown at the right-hand side of Fig. 3.)

It may be advisable in some cases, also, to operate the bits of the projecting-cams without operating the toes of the retracting-cams. For this reason the levers 36 are split for adaptation to the pivot-stems of the toes 34 of the cams, the spring-finger thus formed being acted upon by a clamping-screw 45 when it is desired to clamp the lever to the pivot-pin of the toe. When the lever is loosened, the pivot-pin is held securely in posi-

tion by means of another clamp-screw 46, carried by the cam-plate, as shown in Fig. 9. In like manner the toes of the cams 33 may be operated without operating the bits of the cams 32, by loosening the set-screw 75, whereby the lever 37 is secured to the pivot-stem carrying the notched arm 40.

In order to provide for the operation of one set of cams independently of the operation of another set, the levers of different cams may occupy different vertical planes, as shown, for instance, in Fig. 10, so that a tripping arm or disk which would act upon the levers of one set of cams would not act upon those of the other set.

In machines of this class it is desirable to provide for adjustment of the thread-guide in all directions in order to insure the proper delivery of the yarn to the needles. With this object in view, therefore, we provide the thread-guide 47 with a vertical slot 48, for the reception of a set-screw 49, whereby said guide is secured to the end of an arm 50, which is adapted to and is secured by a set-screw 80 in a bearing in a bracket 51, the base of the latter having segmental slots 52, for the reception of confining-screws 53, so that there may be a vertical adjustment of the guide on the arm, a swinging movement of the arm in the bracket, and a circumferential adjustment of the bracket on the cam-plate, as well as a radial movement of the guide-carrying arm in its bearing, thus providing for such accurate and minute adjustment of the guide as may be required under the different conditions of working of the machine.

In case of breakage or defect of one or more of the needles or of their shanks or bits, and of the necessity of removal of such needle or needles from the needle-cylinder, the top of the cam-cylinder is provided with a detachable plate 54, on the removal of which and the adjustment of this portion of the cam-cylinder to a position in line with the needle or needles to be removed the latter can be lifted by means of a sliding gate 55, so as to be removed from the needle-cylinder.

In machines of the class to which our invention relates, it is usual to provide power-operated take-up mechanism at the lower portion of the frame, so as to cause the tubular web of fabric to be drawn down from the cylinder as fast as it is produced, this mechanism usually comprising a pair of ribbed or fluted rollers 56, carried by a suspended frame, the rollers being driven by spur or ratchet gearing, so as to properly take up the fabric. The objection to this gearing, however, is its intermittent action, and the intermittent strain or pull upon the fabric due thereto. In our machine, therefore, we provide the shaft of one of the rollers with a worm-wheel 57, operated by a worm 58 on a shaft 59, adapted to bearings in the

swinging frame 60, and having a bevel-wheel 61 meshing into a bevel-pinion 62 on a shaft 63, likewise hung to the swinging frame and having a grooved pulley 64, for the reception of a belt 65, running from a grooved pulley 66 on the driving-shaft 6 of the machine. As soon as the length of cloth produced, therefore, is sufficient to permit the drop of the swinging frame to such a position as to tighten the belt 65, the pulley 64 will be rotated, thus rotating the shaft 59 and its worm, and hence imparting a rotating motion to the take-up rolls 56, thus causing the same to rise on the web of fabric, the motion being arrested as soon as the swinging frame has been lifted sufficiently to remove the pulley 64 from driving contact with the belt 65, the motion being resumed on the next descent of the frame to an extent sufficient to tighten the belt.

By the use of the worm-gearing gradual and easy movements are imparted to the take-up rolls, instead of the jerky and intermittent movements caused by the devices hitherto employed.

Counterbalance-weights 67, carried by arms 68 projecting from the frame 60, serve to relieve the web of fabric from a part of the weight of said frame and its take-up rolls. Mounted upon the shaft 69, to which the swinging frame 60 is hung, is a bracket 70, carrying a rod 71, and secured in any desirable position on the latter is another bracket 72, to which is pivoted a mirror 73. This mirror is thus located at the rear of the machine, and provides means whereby the attendant can observe the condition of the rear portion of the tube of fabric which is being delivered by the machine, so that any defect in any part of said tube can be at once noticed by the attendant and the machine stopped until the defect is remedied, whereas in an ordinary machine the front portion only of the tube of fabric is under the eye of the attendant, and defects in the rear portion of the tube are likely to pass unnoticed, and are thus liable to be repeated indefinitely.

It will be evident that many of our improvements are applicable to that class of machines in which the cylinder and dial rotate and the cam-cylinder and cam-plate are stationary.

Having thus described our invention, we claim and desire to secure by Letters Patent—

1. The combination of the needle-cylinder and cam-box of a rib-knitting machine, the needle-dial and dial cam-plate, the supporting-spindle therefor, the supporting-arch, and radial set-screws whereby the spindle may be adjusted laterally in any direction in respect to the hub of the arch, substantially as specified.

2. The combination of the needle-cylinder, cam-box, needle-dial, and dial cam-plate of a rib-knitting machine, the supporting-spindle

and arch for said dial and cam-plate, and mechanism for effecting the lateral adjustment of the same, comprising two sets of radially-arranged set-screws, said sets being in different vertical planes, substantially as specified.

3. The combination of the needle-cylinder and needle-dial of a rib-knitting machine, bearing-lugs carried by the fixed cylinder or frame and the dial and provided with rollers between which the fabric passes, and means for rotating one of the rollers, substantially as specified.

4. The combination of the needle-carrier of a knitting-machine, having grooves or slots for the reception and guidance of the needles, with a hardened ring applied to a recess at the outer end of the carrier and serving as a bearing for the needles and for the fabric as it passes over the edge of the carrier, substantially as specified.

5. The combination of the dial cam-plate of a rib-knitting machine and its needle projecting and retracting cams, each having movable portions with a connected pair of operating-levers, one acting upon the movable portion of the projecting-cam and the other upon the movable portion of the retracting-cam, substantially as specified.

6. The combination of the dial cam-plate and its cams with the pair of connected levers, one operating upon the movable part of the projecting-cam and the other acting upon the movable part of the retracting-cam, and means for releasing one of the levers so as to render one of the cams inoperative, substantially as specified.

7. The combination of the dial cam-plate and its cams with the pair of connected levers, one operating upon the movable part of the projecting-cam and the other acting upon the movable part of the retracting-cam, and means for releasing both of the levers so as to render either of the cams inoperative, substantially as specified.

8. The combination of the dial cam-plate of a rib-knitting machine, the series of cams carried by said plate, and operating-levers for said cams, the levers of some of the cams being in a different vertical plane from those of the other cams, substantially as specified.

9. The combination of the yarn-guide, its carrying-stem and bracket, with provisions for vertically adjusting the guide on the stem and for permitting the stem to be swung in the bracket and to be radially adjusted therein, and provisions for adjusting the bracket circumferentially on the cam-plate of the machine, substantially as specified.

10. The combination of the drive-shaft of the machine and a pulley thereon, the take-up rolls, the pivoted frame carrying the same, a take-up drive-shaft also carried by the frame and having a pulley, a belt adapted to said pulley and to the pulley on the main driving-shaft, a counter-shaft geared to the take-up drive-shaft, and worm-gearing whereby

said counter-shaft is caused to operate one of the take-up rolls, substantially as specified.

11. The combination of the recessed cam-cylinder having a movable gate with a detachable plate closing the top of the recess in which said movable gate operates, substantially as specified.

In testimony whereof we have signed our names to this specification in the presence of two subscribing witnesses.

ROBERT W. SCOTT.
LOUIS N. D. WILLIAMS.

Witnesses:

WILLIAM D. CONNER,
HARRY SMITH.