

F. J. BAILEY.
CLOTHES DRIER.

No. 522,576.

Patented July 10, 1894.

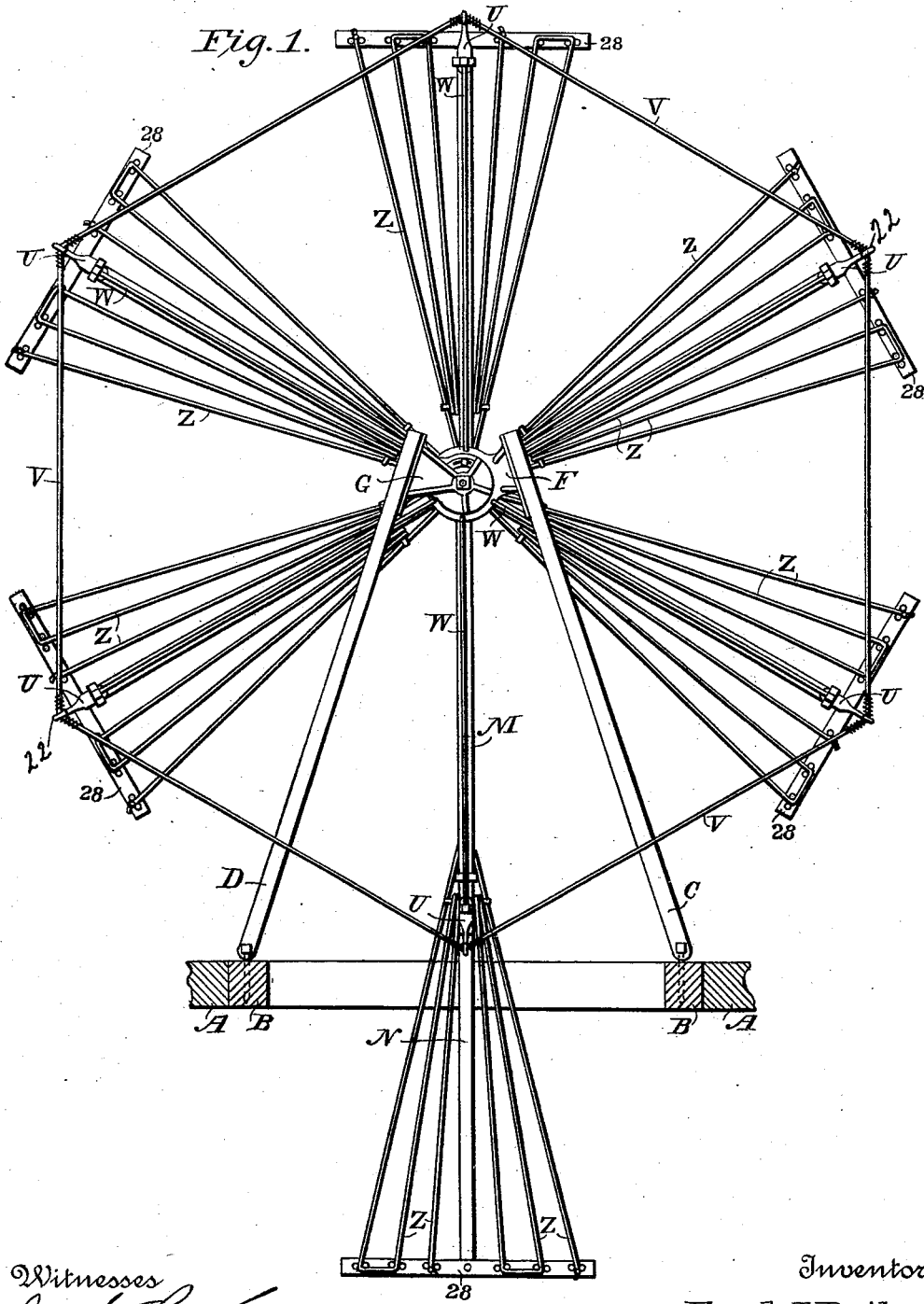

Witnesses
Jos. S. Latimer
Carlton D. Dell.

Inventor
 Frank J. Bailey
by [Signature]
 his Attorney

F. J. BAILEY.
CLOTHES DRIER.

No. 522,576.

Patented July 10, 1894.

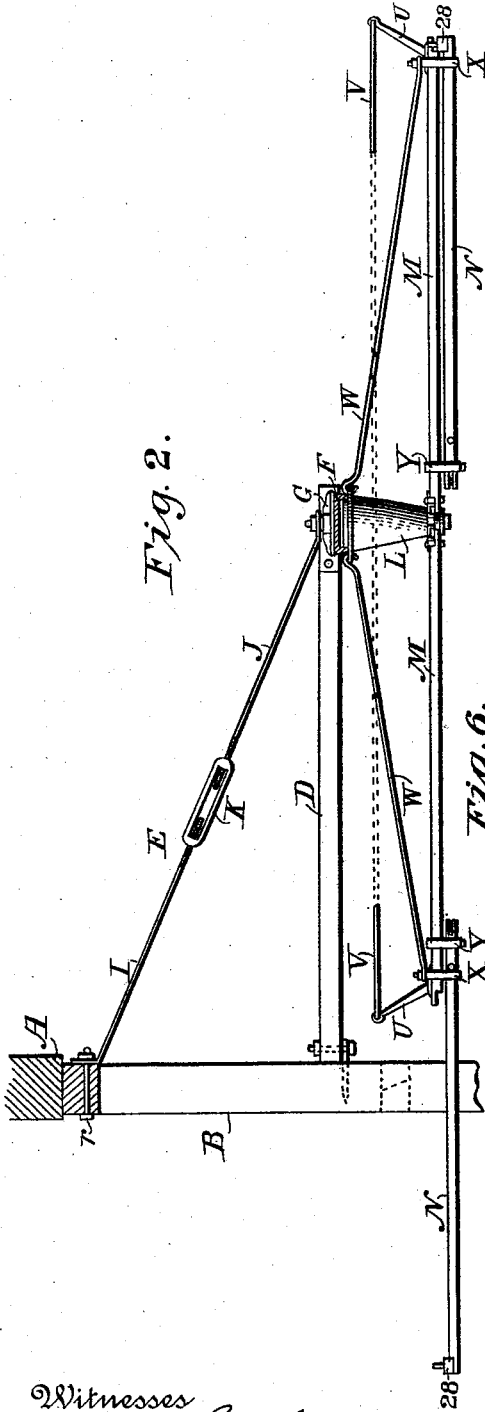

Fig. 2.

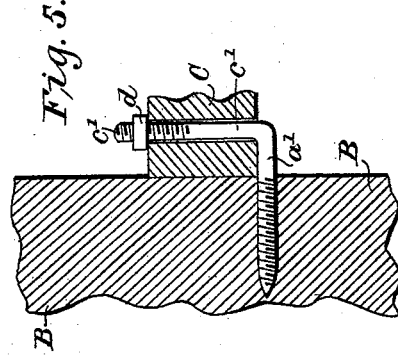

Fig. 5.

Fig. 6.

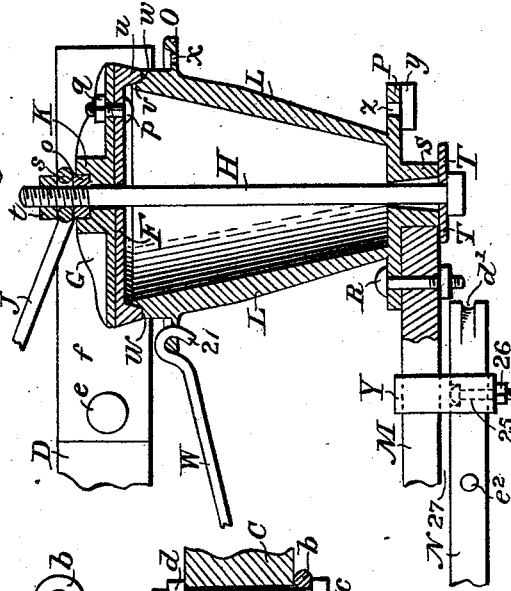

Fig. 4.

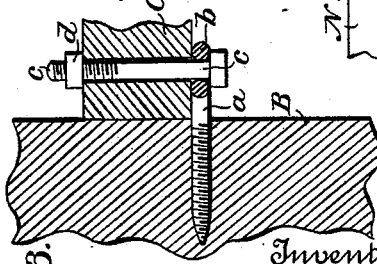

Fig. 3.

Witnesses
J. S. Laidley
Carlton C. Snell

Inventor

Frank J. Bailey

Arthur B. Brown
 his Attorney

F. J. BAILEY.
CLOTHES DRIER.

No. 522,576.

Patented July 10, 1894.

Fig. 7.

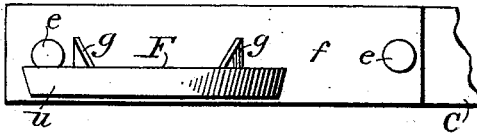

Fig. 9.

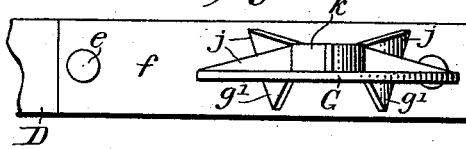

Fig. 8.

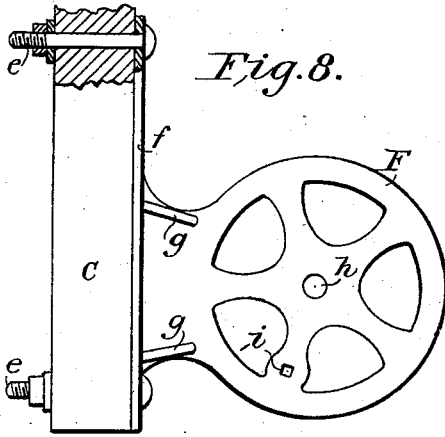

Fig. 10.

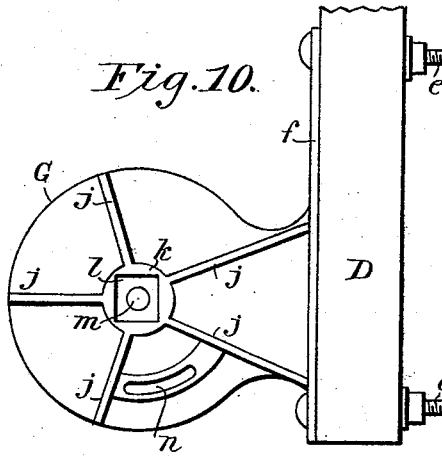

Fig. 11.

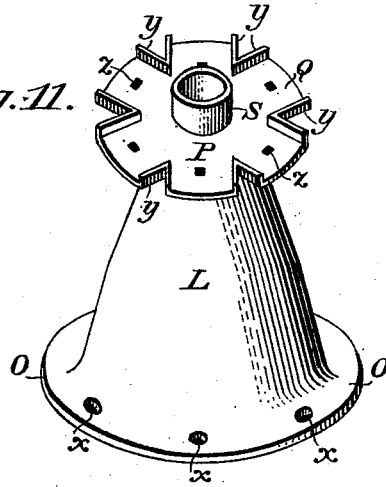

Fig. 13.

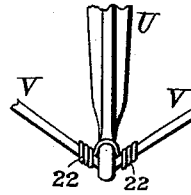
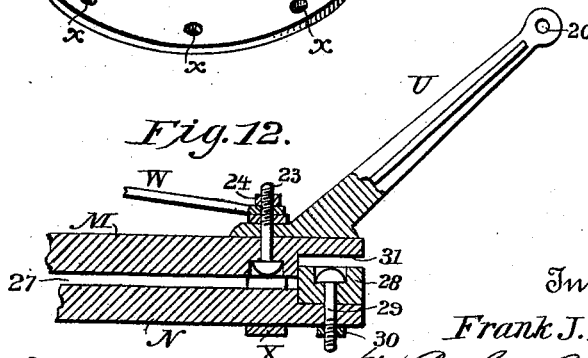

Fig. 12.



Witnesses
Jos. S. Lathrop
Charles E. Snell

Inventor
Frank J. Bailey
Wm. H. Brown
Attorney

F. J. BAILEY.
CLOTHES DRIER.

No. 522,576.

Patented July 10, 1894.

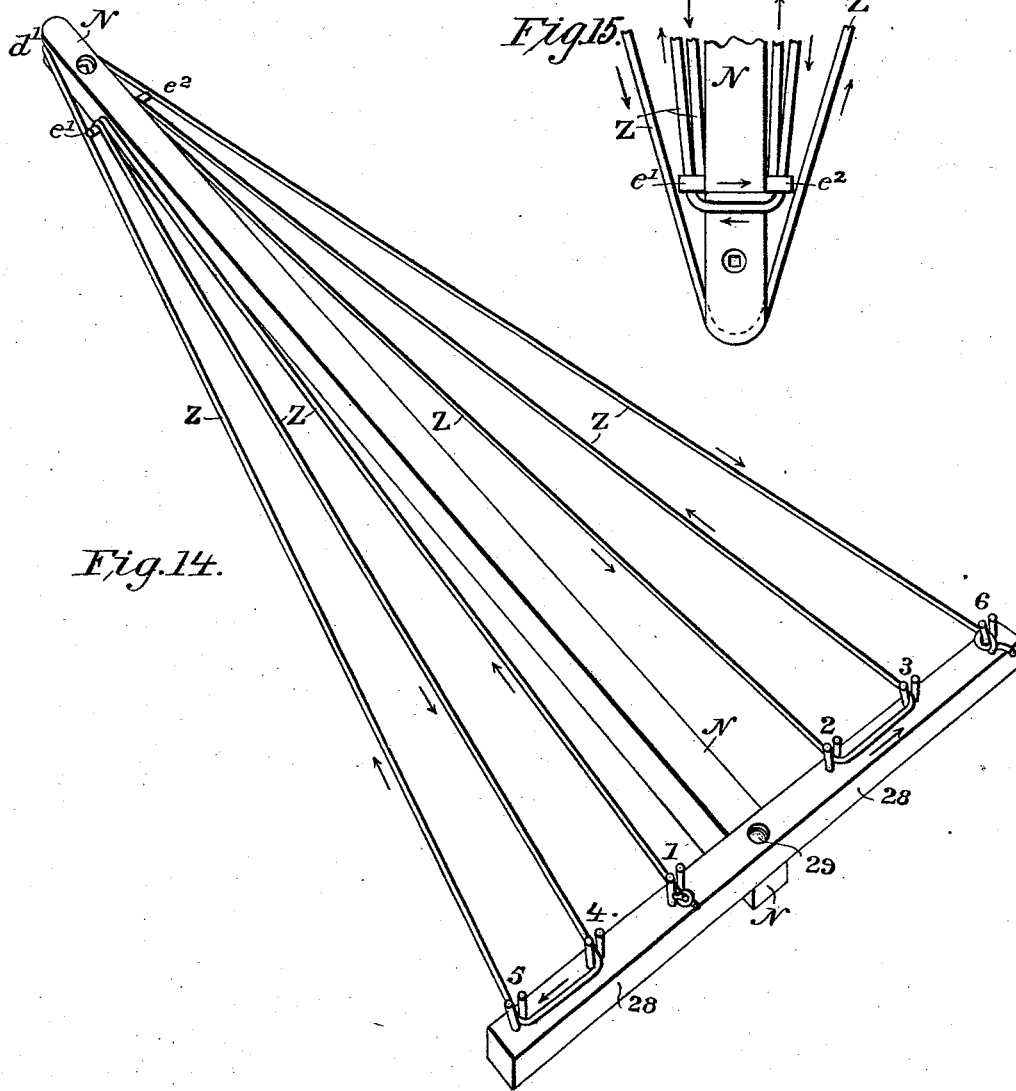

Fig. 14.

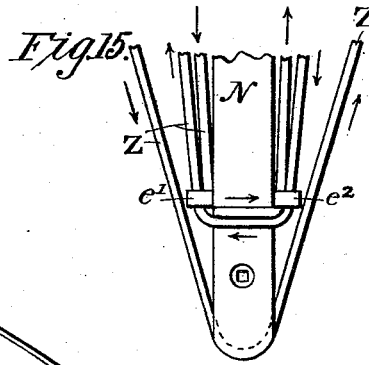

Fig. 15.

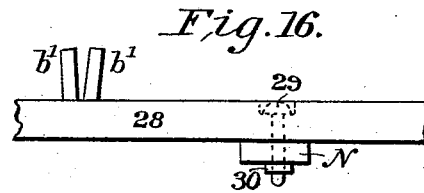

Fig. 16.

Witnesses
Jos. S. Litchner
Carleton C. Snell

Inventor
 Frank J. Bailey
Attorney

UNITED STATES PATENT OFFICE.

FRANK J. BAILEY, OF BRATTLEBOROUGH, VERMONT, ASSIGNOR TO LEVI K. FULLER, OF SAME PLACE.

CLOTHES-DRIER.

SPECIFICATION forming part of Letters Patent No. 522,576, dated July 10, 1894.

Application filed May 17, 1893. Serial No. 474,574. (No model.)

To all whom it may concern:

Be it known that I, FRANK J. BAILEY, of Brattleborough, in the county of Windham and State of Vermont, have invented certain new and useful Improvements in Clothes-Driers, of which the following is a specification.

The present invention consists in improvements upon the clothes driers described in my application for Letters Patent of the United States, filed September 22, 1892, and renewed November 6, 1893, Serial No. 490,170.

The clothes drier to which the present invention relates is a clothes drier comprising a supporting frame which is adapted to be secured permanently on the exterior of the wall of a building and adjacent to a window or door in the wall, and a rotary clothes reel suspended from and rotatively supported by said supporting frame, said reel having a plurality of radial arms, each arm carrying a bar sliding longitudinally thereupon, and each bar being provided with article-holding lines, whereby each bar in turn may be moved in through the window or door and its line laden with clothes and may then be moved out through the window or door. The principal advantage of such a clothes drier, when applied to a wall in connection with a window therein, is that it can be used in tenement and apartment houses where there is no yard space, without necessitating the use of the roof and the attendant climbing of stairs; and when applied to a doorway the clothes can be hung upon the drier within the house, thus obviating the necessity of carrying the clothes from the tubs to the lines, an advantage which is especially conspicuous when snow is on the ground. The present improvements are applied to such a clothes drier, and consist in the improved details of construction hereinafter described and claimed.

The present improvements are illustrated in the accompanying drawings, wherein—

Figure 1, is a horizontal section through a portion of a wall and a window opening therein and looking down upon the improved clothes drier secured to the wall. In this figure the stay-rod of the supporting-frame is not shown. Fig. 2, is a vertical section through a portion of the wall and a window

opening, showing the clothes reel in side elevation. In this figure only two radial arms of the reel and the sliding bars carried thereby are shown, one of the horizontal bars of the supporting frame is removed, and the bearing-plate of the removed bar is shown in vertical section. Fig. 3, is a vertical section through one end of one of the horizontal bars of the supporting frame and a portion of a window or door frame, showing the preferred fastener. Fig. 4, is a detail plan view of the attaching screw shown in Fig. 3. Fig. 5, is a modification of the fastener shown in Fig. 3. Fig. 6, is a vertical section of the hub of the reel, illustrating the connection between the supporting frame and the reel. Fig. 7, is a side view and Fig. 8, a plan view of the outer end of one of the horizontal bars of the supporting-frame. Fig. 9, is a side view and Fig. 10, a plan view of the outer end of the other horizontal bar of the supporting frame. Fig. 11 is a perspective view of the hub of the reel looking at the under side thereof. Fig. 12, is a vertical section of the outer end of one of the radial arms and of the sliding bar carried thereby. Fig. 13, is a plan view of the outer end of one of the metal brackets on the outer ends of the radial arms. Fig. 14, is a perspective view of one of the sliding bars detached, showing the manner of attaching a clothes line thereto. Fig. 15, is a bottom view of the inner end of one of the sliding bars. Fig. 16, is a front view of a portion of one of the sliding bars. A, is a portion of the wall of a building, and B, a portion of an ordinary window frame set therein.

As shown in the drawings, the supporting-frame of the clothes drier is secured to the wall by being fastened to the window frame B. The supporting-frame comprises three principal parts, namely, two horizontal wooden side bars C, D, and a metallic stay-rod E. At their inner ends the two side bars C, D, are attached to the window frame, and at their outer ends they are adjustably connected together so that they can be connected to windows of different widths. The stay-rod E, is connected at its inner and upper end to the window-frame and at its lower outer end to the side bars at the point where they are joined together. The stay-rod is extensible

being capable of longitudinal adjustment so as to be connected with windows of varying heights and widths.

5 The preferred fastener for fastening each of the side bars C, D, to the window frame B is illustrated in detail in Figs. 3, and 4. A shank *a*, having a screw-threaded point and an eyed head *b* is screwed horizontally into the side of the window-frame just above the 10 meeting rails of the window sashes. The inner end of the side bar C (or D, as the case may be) is then rested upon the eyed head *b* of the screw and abutting against the window-frame. A shank *c*, having a head at one end 15 and bolt screw-threads at the other, is then passed vertically upward through the eyed head *b* of the shank *a* and through an aperture in bar C, and is held in place by a nut *d*. The side bars are thus readily and securely 20 attached to the sides of the window-frame just above the meeting rails of the window sashes, by fasteners each of which comprises a horizontally-extending shank which enters the window-frame and a second shank extending 25 vertically and at right-angles to the first shank and which passes through the horizontal bar. A modification of the fastener is illustrated in Fig. 5, wherein the screw-shank *a'* entering the window-frame, and the bolt-shank *c'* 30 passing through the bar, are made in one piece of metal, the bolt-shank itself serving as a handle for turning the screw-shank. This modified fastener is equally as efficient as the preferred construction shown in Figs. 3, and 35 4, except that it cannot be used where the window-frame is narrow and is set into the wall.

The means for adjustably connecting the outer ends of the side bars C, D, together are 40 shown in detail in Figs. 6, 7, 8, 9, and 10. To the outer end of the bar C, on the inner face thereof, there is attached (see Figs. 7, and 8) by bolts *e e* an attaching metal plate *f* which carries an integral horizontally-and-laterally-extending circular plate F. Strengthening 45 ribs *g g* assist in uniting the plate F, and attaching plate *f*. This plate F is flat on its upper surface and has a central aperture *h* and an eccentric aperture *i*. The other side 50 bar D (see Figs. 9, and 10) has connected with it by bolts *e e* a similar metal attaching plate *f* which carries an integral horizontally-and-laterally-extending cap-plate G, provided with strengthening ribs *g' g'* beneath and 55 strengthening ribs *j j* above. The lower face of the cap-plate G is flat so as to rest upon the flat upper face of the plate F. The cap-plate G has on its upper face and at the center a projecting boss *k* having a polygonal 60 recess *l*. The cap-plate has also a central aperture *m* (communicating with said recess *l*) and a concentric slot *n* at the same distance from the center as is the aperture *i* of plate F. The two plates F and G are connected 65 together by a pivot-pin or king-bolt H (see Fig. 6) which extends through the two central apertures *h* and *m*, and which is held

in place by a polygonal nut *o* which seats non-rotatively in the polygonal recess *l*. 70 When the plates F G of the two side bars C D are thus united, the latter can turn on the pivot-pin or king-bolt so that their inner ends can be spread apart or brought together to any desired extent to enable them to fit any 75 window. When the bars C D have been thus placed in position, they can be locked together if desired by means of suitable locking provisions such as a locking and adjusting bolt *p* (see Fig. 6) passing through the 80 eccentric aperture *i* in plate F and slot *n* in cap-plate G, in connection with a nut *q*.

The extensible stay-rod E is composed of two metal rods I J, screw-threaded in opposite directions at their adjacent ends, and an intermediate turn-buckle K, whereby the 85 stay-rod may be lengthened or shortened as desired to accommodate it to windows of different heights and widths. The upper end of the upper rod I, is bolted by bolt *r* to the window-frame (see Fig. 2), and the lower end 90 of the lower rod J, has an eye *s* which fits over the upper end of the king-bolt or pivot-pin H and is fastened thereto by a lock-nut *t* (see Fig. 3). This lock-nut *t* not only secures the stay-rod to the bars C D, but also 95 acts as a lock-nut to prevent the accidental turning of the pivot-pin or king-bolt H. The supporting frame of the clothes drier is thus securely fastened to the window-frame or 100 other part of the wall, and the side bars C D are maintained in horizontal position.

The rotary reel which is suspended from the supporting-frame comprises, as in my aforesaid application, Serial No. 490,170, a central 105 hub L, a plurality of wooden radial arms M M secured at their inner ends to said hub, and a plurality of suspended wooden sliding bars N N mounted and sliding upon said arms M M respectively. The central hub L of the reel is now differently constructed. It is 110 shown best in Figs. 6, and 11. It is composed of a single hollow metal casting. The upper edge of the hub constitutes a lower bearing-plate co-operating with the under side of the plate F, which constitutes an upper non-rotating 115 bearing plate. On its under side the bearing-plate F has a depending circular flange *u* coned on its inner side, and within this seats a flange *v* extending upwardly from the hub and coned on its exterior to fit within 120 the depending flange *u*. The shoulder *w* formed by the flange *v* at the upper end of the hub seats against the lower edge of the depending flange *u*. The coned inner face of the flange *u* constitutes an upper journal 125 bearing for the hub, and the shoulder *w* of the hub and the co-operating lower edge of flange *u* constitute bearing faces to prevent the rocking or tilting of the hub. Immediately below its upper edge the hub has a horizontally-projecting peripheral flange O, provided 130 with apertures *x x* the purpose of which will presently appear. At its lower end the hub has a horizontal plate P, provided with de-

pending flanges $y y$ which divide the plate into six sections $Q Q$ for receiving the radial arms $M M$ of which there are six. Each section Q of plate P has a bolt aperture z . Each radial arm M is secured to the hub by having its inner end seated against the under side of plate P within one of the sections Q and between two of the flanges $y y$ (which prevent lateral movement to the radial arm), and it is bolted in place by a bolt R , extending through aperture z . Beneath the plate P , the hub has a central depending boss S , with a central aperture through which passes the pivot-pin or king-bolt H . The inner ends of the radial arms M abut against this boss S . A non-rotating step-plate T seats against the lower end of this boss S , and extends beneath the inner ends of the radial arms, and is held in place by the head of the king-bolt. This step-plate T , receives the friction of the rotating hub, and takes it off from the head of the king-bolt. The king-bolt itself, where it passes through the boss S , constitutes the lower bearing for the hub.

To each radial arm M , at the outer end thereof, there is attached an upwardly-and-outwardly-extending metal bracket U , having an eye 20 (see Fig. 12) in its upper end, and the brackets U of all of the radial arms are connected by a peripheral line V (preferably of wire) which extends through the eyes 20 of the several brackets, as shown in Fig. 1, and all as in my aforesaid application Serial No. 490,170. Also, as in said application, a stay-rod W connects the outer end of each radial arm with the hub, each stay-rod W having a hook 21 at its inner end which hooks into one of the apertures z in the flange O , of the hub (see Fig. 6). In order that the peripheral line V , may be of service to maintain the radial arms at equal distances, it is fastened to each of the eyes 20 of the brackets U by a wire 22 , as shown most clearly in Fig. 13.

Each of the sliding bars N , of which there is one for each radial arm M , is connected to and suspended from its radial arm by means substantially the same as in my said application Serial No. 490,170. A guiding and supporting metallic strap or loop X is secured so as to depend from the outer end of each radial arm. This strap X is attached to the radial arm by a bolt 23 , and nut 24 , which also serve to secure the bracket U and stay-rod W to the radial arm. The corresponding sliding bar N is located beneath its radial arm M , and slides within and rests upon the portion of the strap X depending below the radial arm, as shown most clearly in Fig. 12.

Near the inner end of each sliding bar N , there is attached thereto an upwardly-extending guiding and supporting metallic strap or loop Y (see Fig. 6), which is secured to bar N by bolt 25 , and nut 26 , and which embraces and slides along the corresponding radial arm M . The only difference between the connecting means of the arms M and N of the pres-

ent case and those of said application Serial No. 490,170, is that the strips X , and Y , are of sufficient length to leave a space 27 (see Fig. 6) between each arm M and its bar N . This space has been found to be an important feature, since the reel is exposed to the weather, and the radial arms and sliding bars being made of wood are liable to swell and bind together in wet weather if in contact with each other. The presence of the spaces 27 permits the free sliding of the bars at all times. Also, in case of snow or ice lodging between the arms and bars, the play afforded by this space permits the bars to be agitated so as to break off and detach any ice or snow.

Each sliding bar N carries by itself and independently of the other parts of the reel longitudinally-extending article-holding lines, as in said application, Serial No. 490,170, but improvements have been introduced in the manner of securing the lines, which are shown in detail in Figs. 14, 15, and 16. Each bar carries at its outer end a line-spacing-and-holding wooden cross-head 28 , extending horizontally and at right-angles to the bar N . This cross-head 28 , is secured at its center to bar N by bolt 29 , and nut 30 (see Fig. 12). The bar N is rabbeted at its end to receive the cross-head (as is also the arm M at 31 , see Fig. 12) which is of uniform size throughout. The line-holders consist of a plurality of pairs of wooden pegs b', b' , extending upwardly from the top face of the cross-head 28 , a groove d' at the extreme rear end of the bar N (see Fig. 6), and a wooden pin extending horizontally through and on either side of the bar near its rear end so as to furnish projections $e' e''$ on opposite sides of the bar. The wooden pegs b', b' , of each pair (constituting one holder) incline away from each other (see Fig. 16) being nearly in contact at their lower ends and spreading thence apart, so that a wedge-shaped opening is provided between them for the insertion and retention of the clothes-line.

The line Z employed is an ordinary clothes-line, and only one line is required for each sliding bar. The lines need not be sold with the clothes reel, since any ordinary clothes-line can be attached to the bar.

The line Z is attached in the following manner (see Fig. 14):—A knot is tied in one end of the line and the line close to the knot is squeezed between the pair 1, of the pegs b' on one side of the cross-head nearest the bar N . The line is carried longitudinally over the projection e' ; thence under the bar N (see Fig. 15); thence over projection e'' ; thence to the pair 2 of pegs on the opposite side of the cross-head nearest the bar, between which the line is squeezed; thence to intermediate pair 3 of pegs, between which the line is squeezed; thence over projection e'' ; thence under bar N ; thence over projection e' ; thence to the intermediate pair 4 of pegs, between which it is squeezed; thence to the outer pair 5 of the pegs at one end of the cross-head be-

tween which it is squeezed; thence around groove d' in the end of the bar; and thence to the outer pair 6 of the pegs on the opposite end of the cross-head between which the line is squeezed and around which the line is given an additional twist to firmly secure the end thereof. The cross-heads can be lengthened and more than six holders thereupon can be employed if a larger line-holding capacity is desired. The course which the line follows is indicated by arrows in Figs. 14, and 15.

By thus attaching the clothes-lines, several important advantages result. The different longitudinally-extending sections of the line are properly spaced so that each can hold articles to be dried; the line can be easily and readily removed after each use of the drier so as not to be subjected to the deteriorating effect of the weather; ordinary clothes-pins can be used for attaching the clothes to the line (the peripheral line V being maintained by the brackets U so far above the lines Z that it does not interfere with clothes-pins on the lines Z); and a full-length sheet can be attached to the line without any folding thereof except the longitudinal fold which is given to it when hung upon an ordinary clothes-line. As the reels are ordinarily constructed, the length of the line Z from the holder 5 around the holder d' at the inner end of bar N to holder 6 is about eight feet, whereas the length of a sheet is about seven feet. In attaching such a sheet to the line, the end of the clothes-line is detached from the holder 6, and the length of the line from holder 5 to holder 6 is brought within the room. The sheet is then placed upon the line, and the line with the sheet attached is then placed and fastened in position, the sheet also passing around the inner end of the bar N. The capability of thus hanging a full-length sheet upon the clothes-line is due not only to the manner of attaching the clothes-line but also to the facts that each sliding bar is suspended from its radial arm so that there is nothing in the way of a sheet suspended therefrom, and that the inner end of the sliding bar is wholly unobstructed by any part of the drier so that the line with the sheet upon it can be freely passed therearound.

The manner of using the drier as a whole is similar to that of using the drier shown in my said application Serial No. 490,170. A sliding bar opposite the window opening is slid through the window within the room where the washing is being done, as shown in Figs. 1, and 2. Its lines are then filled with articles of clothing, and it is then slid out of the window. The reel is turned until the next sliding bar is in front of the window, and it is likewise slid into the room, filled, and slid out. In this manner, each of the sliding bars is filled. After all of the sliding bars are filled, articles may be hung upon the peripheral line V. The capacity of the drier is large.

The entire construction of the reel is strong, simple, efficient, inexpensive, and durable.

Since the lines extend longitudinally along the bars, there is no danger of the clothes on the lines being blown by the wind against the wall of the building.

The drier has been illustrated and described as used in connection with a window. When so used the drier should be so located (as shown) that the sliding bars are in a plane sufficiently below the meeting rails of the window sashes so that the clothes pins upon the lines Z Z will pass beneath the window sashes when the lower sash is fully raised.

When applied to a doorway, the entire drier is elevated so that the sliding bars with clothes-pins attached pass freely beneath the top of the door-frame in sliding through the doorway. The line can then be easily reached, and the drier does not interfere with the ordinary use of the doorway.

I claim as my invention—

1. In a clothes-drier, a rotary clothes-reel, and an adjustable supporting frame therefor comprising two supporting bars adapted to be fixed to a wall at their inner ends on the opposite sides of a window or door opening in said wall and pivotally connected together at their outer ends whereby said frame may be adjusted to wall openings of different widths, said rotary clothes reel being supported at the outer end of said frame, in combination with a single king-bolt which constitutes the axis of the rotary clothes reel and the pivot-pin for the outer ends of said supporting bars, substantially as set forth.

2. In a clothes-drier, a rotary clothes-reel, and an adjustable supporting frame therefor comprising two supporting bars adapted to be fixed to a wall at their inner ends on the opposite sides of a window or door opening in said wall and pivotally connected together at their outer ends whereby said frame may be adjusted to wall openings of different widths, said rotary clothes-reel being suspended from the outer end of said frame, in combination with an extensible stay-rod adapted to be attached at its upper end to the wall above the opening therein and at its lower end to the outer end of said frame, and a single king-bolt which constitutes the axis of the rotary clothes reel, the pivot-pin for the outer ends of the supporting bars, and the attachment for the lower end of said stay-rod, substantially as set forth.

3. An adjustable supporting-frame for a clothes-drier comprising in combination two supporting bars adapted to be fixed at their inner ends and pivoted together at their outer ends, and provisions carried by said bars respectively for locking them together in their different positions, substantially as set forth.

4. The combination of the two bars C and D of the supporting-frame of a clothes-drier, one of said bars having the laterally-extending plate F having a flat upper face and a central aperture, and the other of said bars having a laterally-extending plate G having a flat lower face and a central aperture, said two plates

lying one above the other with their flat faces together, and a pivot-pin or king-bolt passing through said central apertures, substantially as set forth.

- 5 5. The combination of the two bars C and D of the supporting-frame of a clothes drier, one of said bars having a laterally-extending plate F with a central aperture *h* and an eccentric aperture *i*, the other of said bars having a
10 laterally-extending plate G with a central aperture *m* and a slot *n*, said plates lying one above the other, a king-bolt or pivot-pin extending through said apertures *h* and *m*, and a locking and adjusting bolt extending through
15 said aperture *i* and slot *n*, substantially as set forth.
6. The two supporting bars of a clothes-drier having connecting plates lying one above the other with central apertures in each
20 and a central polygonal recess in one, in combination with a stay-rod having an eye at one end, a pivot-pin or king-bolt extending through said apertures, recess and eye, a polygonal nut for said pivot-pin or king-bolt located in said polygonal recess and on one side
25 of the eyed end of said stay-rod, and a lock-nut for said pivot-pin or king-bolt on the opposite side of the eyed end of said stay-rod, substantially as set forth.
- 30 7. The hollow rotary metallic hub of a

clothes reel having radial arms and supporting stay-rods therefor, comprising in one piece of metal the upper flange *O* having apertures
35 *x* for the attachment of the stay-rods, the lower horizontal plate *P* with depending flanges *y* dividing said plate into sections *Q* for receiving the ends of the radial arms of the reel, the plate *P* having at each of said sections *Q*
40 bolt-holes for the attachment of the radial arms, and a hollow boss *S* against which the inner ends of said radial arms abut and through which extends the bolt upon which
45 the hub turns, substantially as set forth.

8. The non-rotating bearing-plate *F*, and the non-rotating step-plate *T*, in combination
50 with the hollow depending rotating metallic hub located between said plates *F* and *T*, and the king-bolt extending upwardly through said step-plate, hollow hub, and plate *F*, and supported in place above said plate *F*, the
55 head of said king-bolt being below said step-plate *T*, substantially as set forth.

In witness whereof I have hereunto signed my name in the presence of two subscribing witnesses.

FRANK J. BAILEY.

Witnesses:

GEORGE B. HITT,
FRANK G. KETCHUM.