

(No Model.)

C. P. McCLANATHAN.
TIP CART OPERATING DEVICE.

No. 524,787.

Patented Aug. 21, 1894.

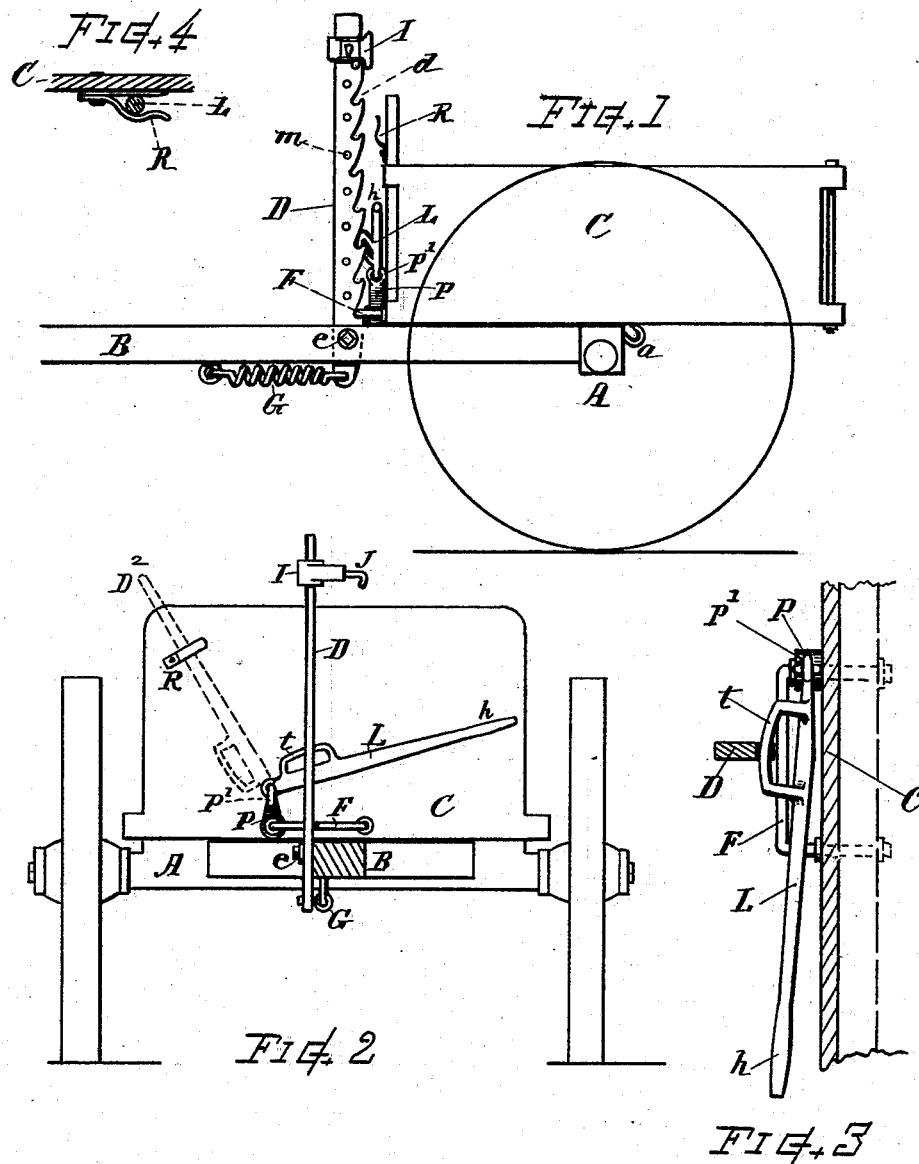

Witnesses

W. B. Barton
Simon King

Inventor

Charles P. McClanathan
By *Chas. H. Burleigh*
Attorney

UNITED STATES PATENT OFFICE.

CHARLES P. McCLANATHAN, OF OAKHAM, MASSACHUSETTS.

TIP-CART-OPERATING DEVICE.

SPECIFICATION forming part of Letters Patent No. 524,787, dated August 21, 1894.

Application filed February 5, 1894. Serial No. 499,120. (No model.)

To all whom it may concern:

Be it known that I, CHARLES P. McCLANATHAN, a citizen of the United States, residing at Oakham, in the county of Worcester and State of Massachusetts, have invented a new and useful Tip-Cart-Operating Device, of which the following, together with the accompanying drawings, is a specification sufficiently full, clear, and exact to enable persons skilled in the art to which this invention appertains to make and use the same.

This invention relates to an improvement in mechanism of the kind described in my previous Letters Patent, No. 513,132; the object of my present invention being to provide, in combination with a tip-cart holder and supporter, a lever appliance adapted for operating in conjunction with the notched supporter to aid the operator in easily tilting the cart-body when heavily loaded, as more fully hereinafter described.

In the drawings, Figure 1 is an outline side view of a tip-cart showing my invention as applied thereto. Fig. 2 is a front view of the same. Fig. 3 is a plan view of the lifter and adjacent parts in detail, and Fig. 4 is a view of the lever-retaining clip.

Referring to parts, A indicates the axle; B the tongue; C the tilting cart-body pivoted at *a* to tip backward; D the upwardly projecting supporter pivoted to the tongue at *e* and having the series of upwardly directed teeth or notches *d* along its edge adapted for engaging the body-iron or loop F that retains the adjustment of and is fixed to the front of the cart-body.

G denotes the supporter-spring; I the locking device or slide-block adjustable on the bar D, and J the locking bolt for securing the slide at position of adjustment on the bar by engagement with one of the holes *m* therein.

All of the above named parts may be constructed as shown or as heretofore employed in my previous invention, set forth in the patent above mentioned; and need not be herein more particularly described in individual detail.

In accordance with my present invention I arrange at the front of the body a lifting hand-lever L in the following described manner:— An attaching piece or link P is securely connected to the body-iron F (or to the body-

frame adjacent thereto) at about three inches, more or less, from the bar D, and provided at its upper end with an eye P'. In said eye is loosely connected, by a loop or equivalent joint, the end of the arm or lever L which extends past the rear edge of the supporter D along the front of the cart-body; said lever being of sufficient length to afford a liberal purchase. The free end of the lever is properly rounded or formed with a convenient handle, as at *h*, and the lever is furnished with an overhanging loop or edge *t* of suitable form and size for taking into or engaging with the several notches or teeth *d* of the supporter bar D that acts as a fulcrum for the same. Said loop is preferably slightly curved, as shown, to accommodate the swing of the parts when in use.

A retaining clip R is attached to the upper part of the body front into which the arm of the lever L can be adjusted (see dotted lines D² Fig. 2) and there retained out of the way of the holding devices when not required for use.

In the operation, the lever is brought down to working position, as in full lines Fig. 2. The operator then taking hold of the handle *h* raises the lever and hooks its edge or loop *t* into one of the ratchets *d* of the bar D; then by pressing down the long arm of the lever L the front end of the cart-body and load is lifted by the short arm and attaching piece P, the lever acting over the tooth of the bar D as a fulcrum, thereby carrying the body-iron F upward along the bar D until it can be entered into a higher notch than it before occupied, where it will be readily engaged by permitting the backward swing of the supporter-bar; the loop *t* is then released from the notch *d* which it occupied, the handle of the lever raised, and the loop *t* re-engaged in a higher notch and the lifting operation, as above noted, is repeated elevating the body another notch, and so on by easy steps until the cart-body is tilted to a convenient height. The lever can then be swung up into the clip R, and the body overturned the rest of its distance, if desired, by a light push by the operator. By this mechanism a heavily loaded cart can be readily tilted or tipped, as required, by a single person and without great labor. The mechanism is simple and inex-

pensive for manufacture and application to use.

What I claim, and desire to secure by Letters Patent, is—

5 1. A tip-cart operating device comprising, in combination with the cart-body, and its draft tongue, an upwardly projecting supporter attached to the tongue, and having a series of notches or upwardly directed teeth, 10 and a swinging hand lever fitted for engagement with said notched supporter, its short arm end flexibly connected with the cart-body; said lever adapted for operation in conjunction with the several teeth of said supporter as a fulcrum, substantially as and for 15 the purpose set forth.

2. The combination with the tongue and body in a tip-cart, and a backwardly and forwardly swinging support-bar pivoted to the 20 tongue and provided with a series of ratchets or notches along its edge, a body-iron fixed to the front end of the cart-body, adapted for engaging said notches, and a spring that normally swings said support-bar toward the

cart-body, of a hand-lever its end loosely 25 jointed by an attaching piece or link in connection with the body-iron, and having an edge or loop for engaging with the notched support-bar, for the purposes set forth.

3. The lifter-lever provided with an over- 30 hanging engaging loop, and having its longer end formed as a handle and its shorter end loosely connected by a suitable joint-piece with the body, and a lever-holding clip attached to the body-front, in combination with 35 the tilting cart-body, the tongue, the notched supporting bar pivoted to the tongue, the support-bar spring, the body-iron and the holder adapted for sustaining the tilting body at position of adjustment, all substantially as 40 shown and described.

Witness my hand this 29th day of January, A. D. 1894.

CHARLES P. McCLANATHAN.

Witnesses:

ALBERT E. RICE,
CLINTON C. COOK.