

(No Model.)

6 Sheets—Sheet 1.

E. B. ALLEN.

CARPET HOLDING AND SEWING APPARATUS.

No. 524,997.

Patented Aug. 28, 1894.

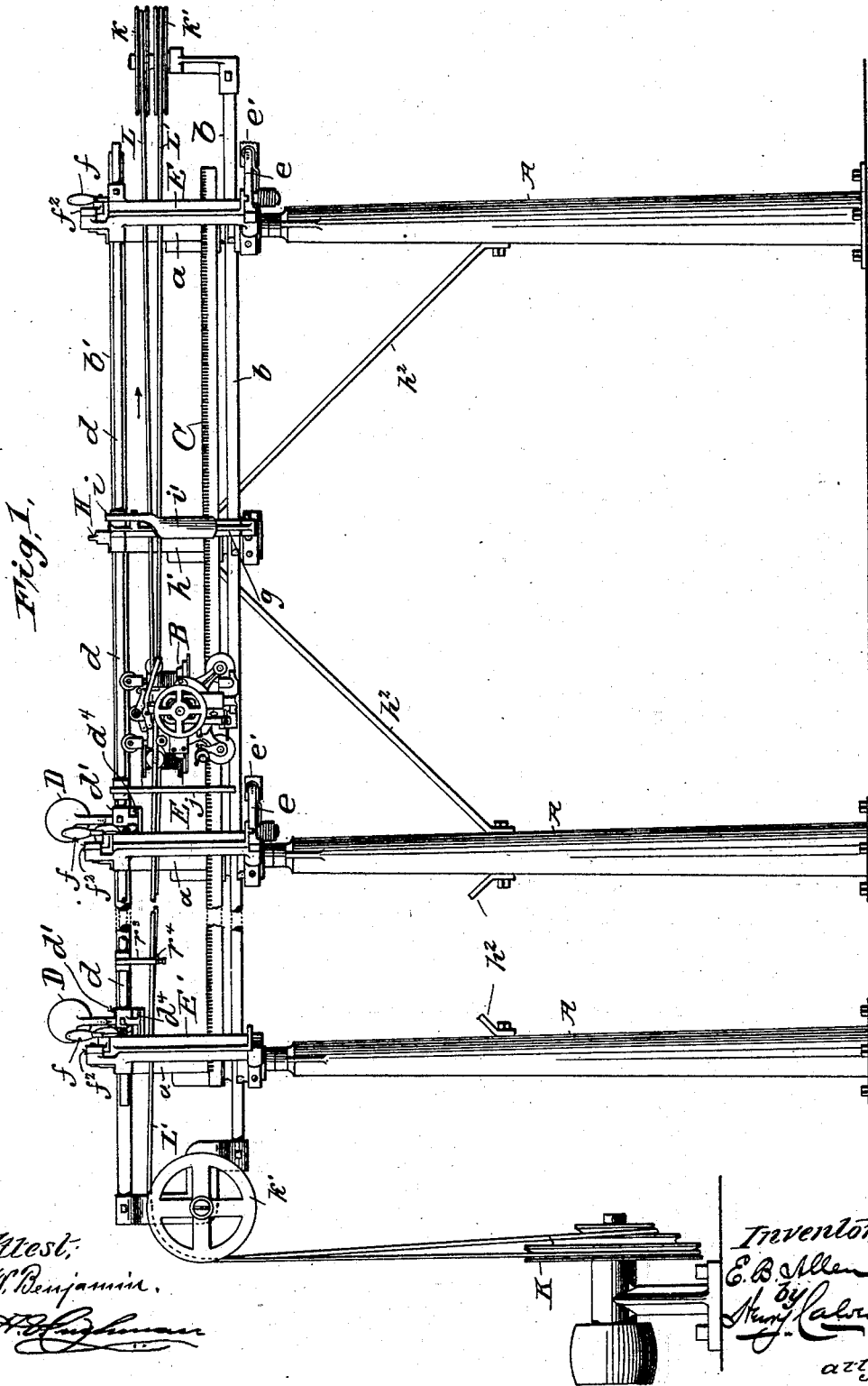

(No Model.)

6 Sheets—Sheet 2.

E. B. ALLEN.
CARPET HOLDING AND SEWING APPARATUS.

No. 524,997.

Patented Aug. 28, 1894.

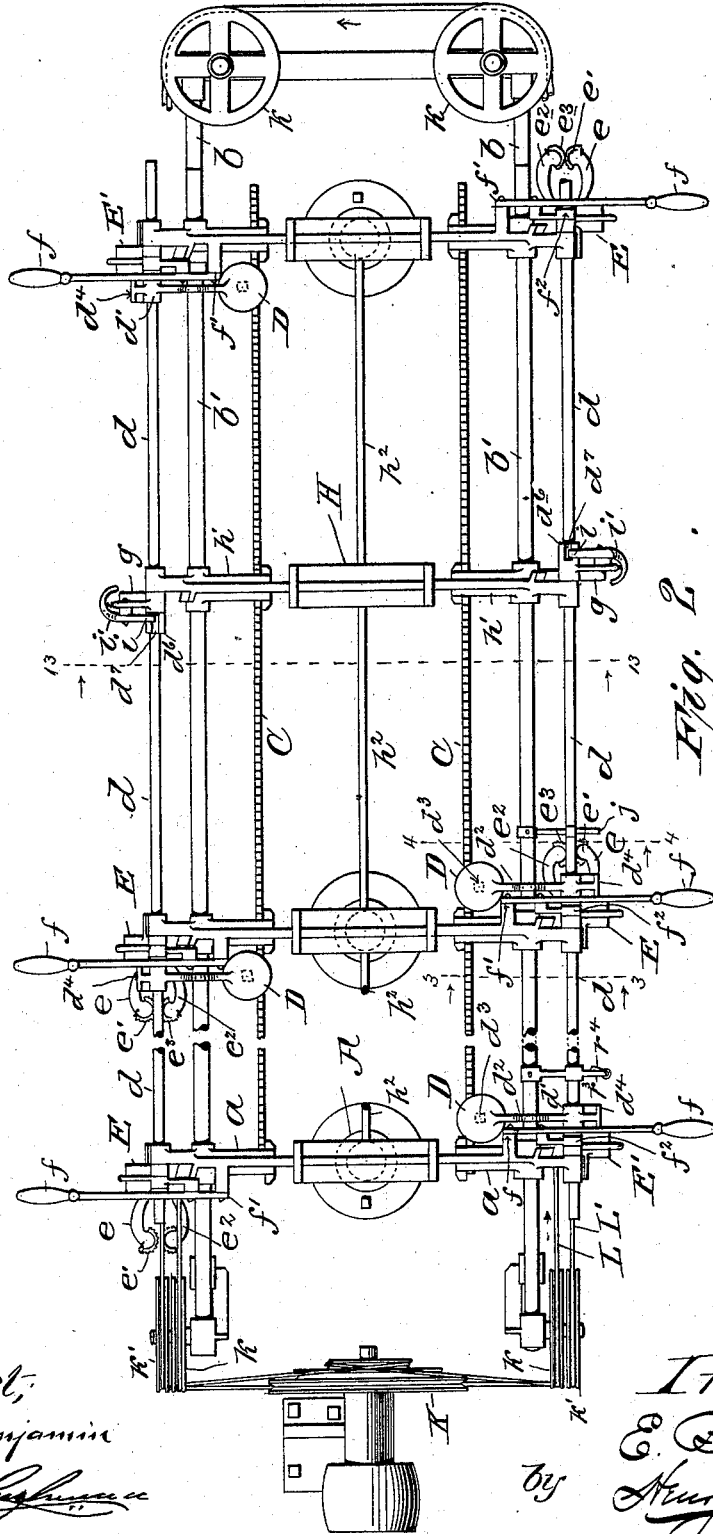

Fig. 2.

Attest:
C. W. Benjamin
H. J. [Signature]

Inventor:
E. B. Allen
by
H. J. [Signature]
Atty.

E. B. ALLEN.
CARPET HOLDING AND SEWING APPARATUS.

No. 524,997.

Patented Aug. 28, 1894.

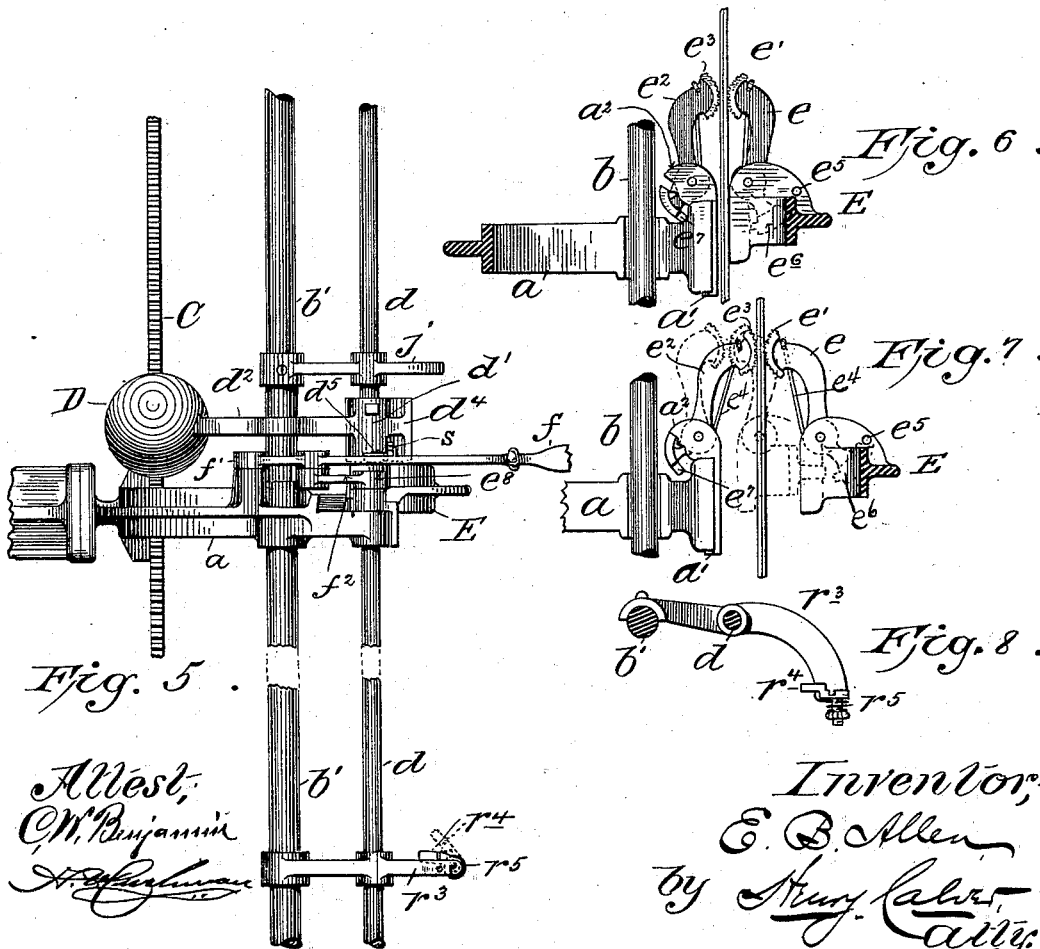
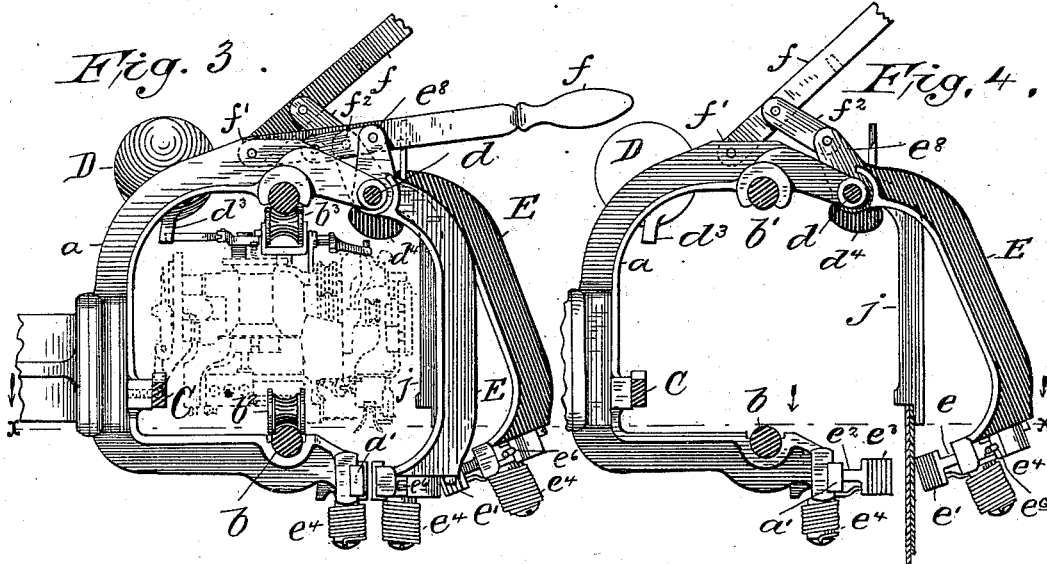

Attest:
C. W. Benjamin
Notary Public

Inventor,
E. B. Allen
 by *Henry Law*
att'y.

E. B. ALLEN.
CARPET HOLDING AND SEWING APPARATUS.

No. 524,997.

Patented Aug. 28, 1894.

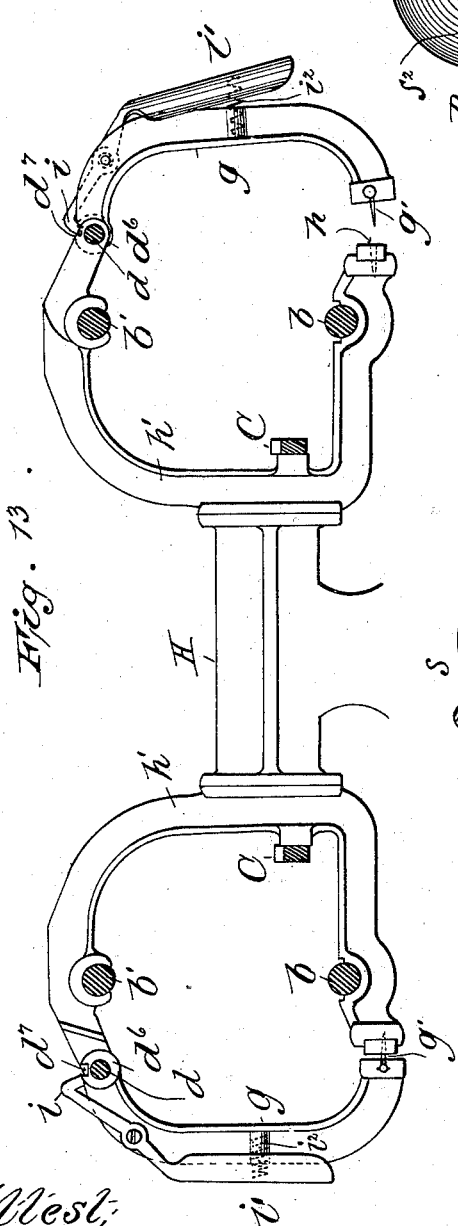

Fig. 9.

Fig. 10.

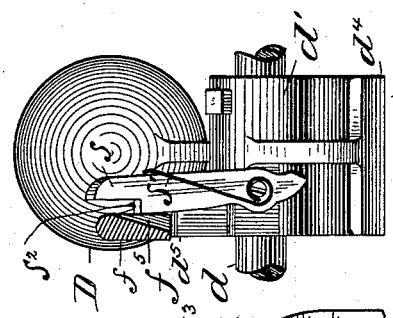

Fig. 11.

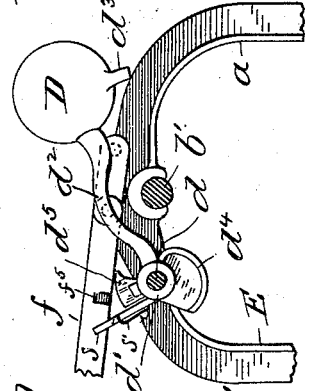

Fig. 12.

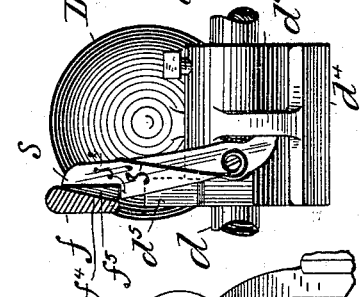

Fig. 13.

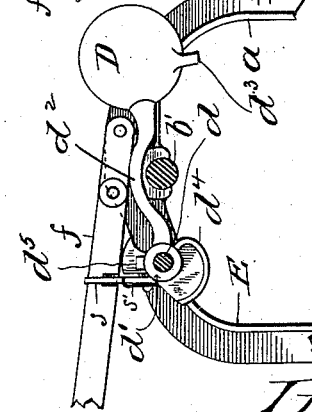

Fig. 14.

Attest:
C. W. Benjamin
H. G. Johnson

Inventor:
E. B. Allen
by Henry Labar
att'y.

(No Model.)

6 Sheets—Sheet 5.

E. B. ALLEN.

CARPET HOLDING AND SEWING APPARATUS.

No. 524,997.

Patented Aug. 28, 1894.

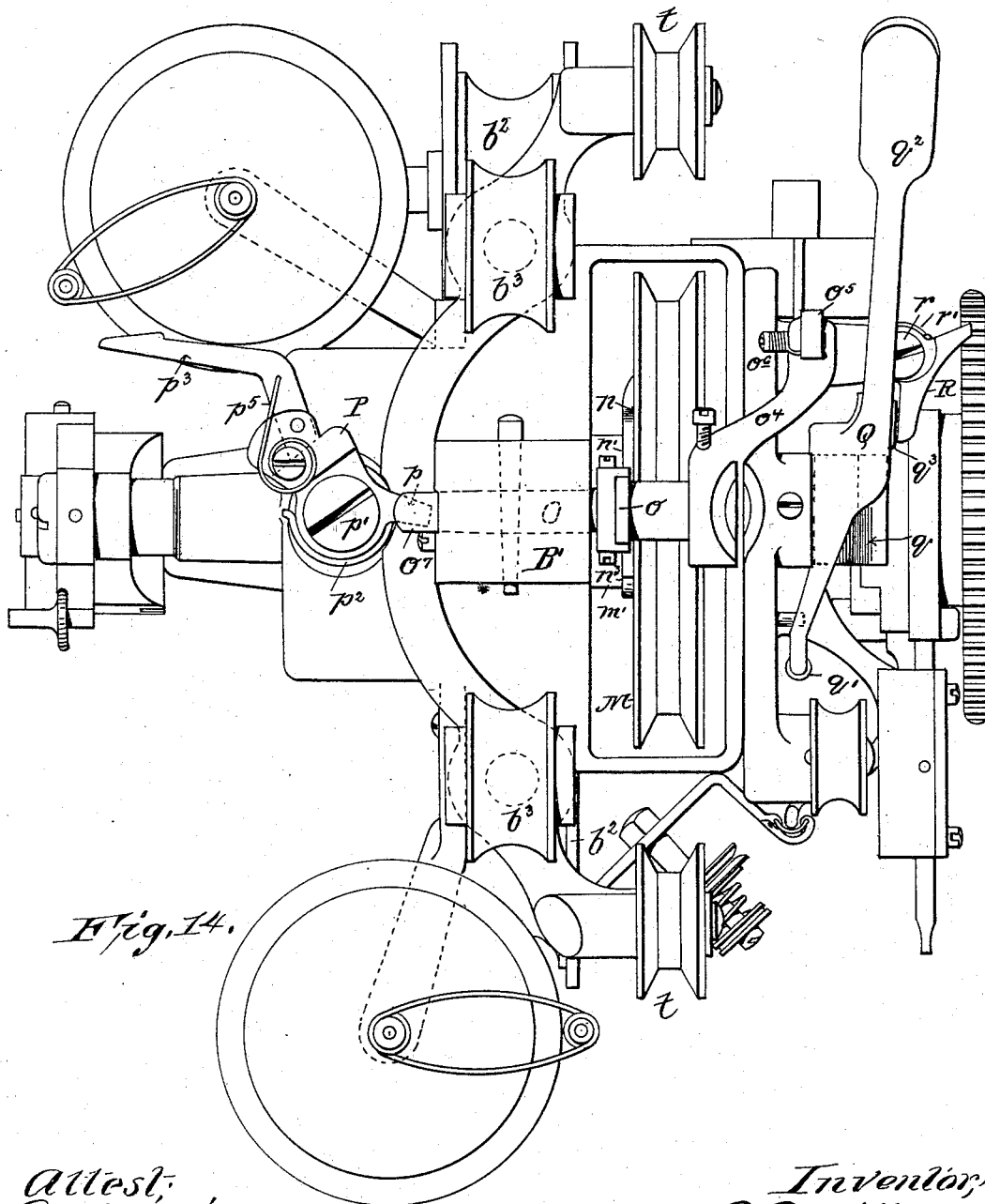

Fig. 14.

Attest:
C. W. Benjamin
H. J. Johnson

Inventor:
E. B. Allen
by Henry C. Allen
att'y.

(No Model.)

6 Sheets—Sheet 6.

E. B. ALLEN.
CARPET HOLDING AND SEWING APPARATUS.

No. 524,997.

Patented Aug. 28, 1894.

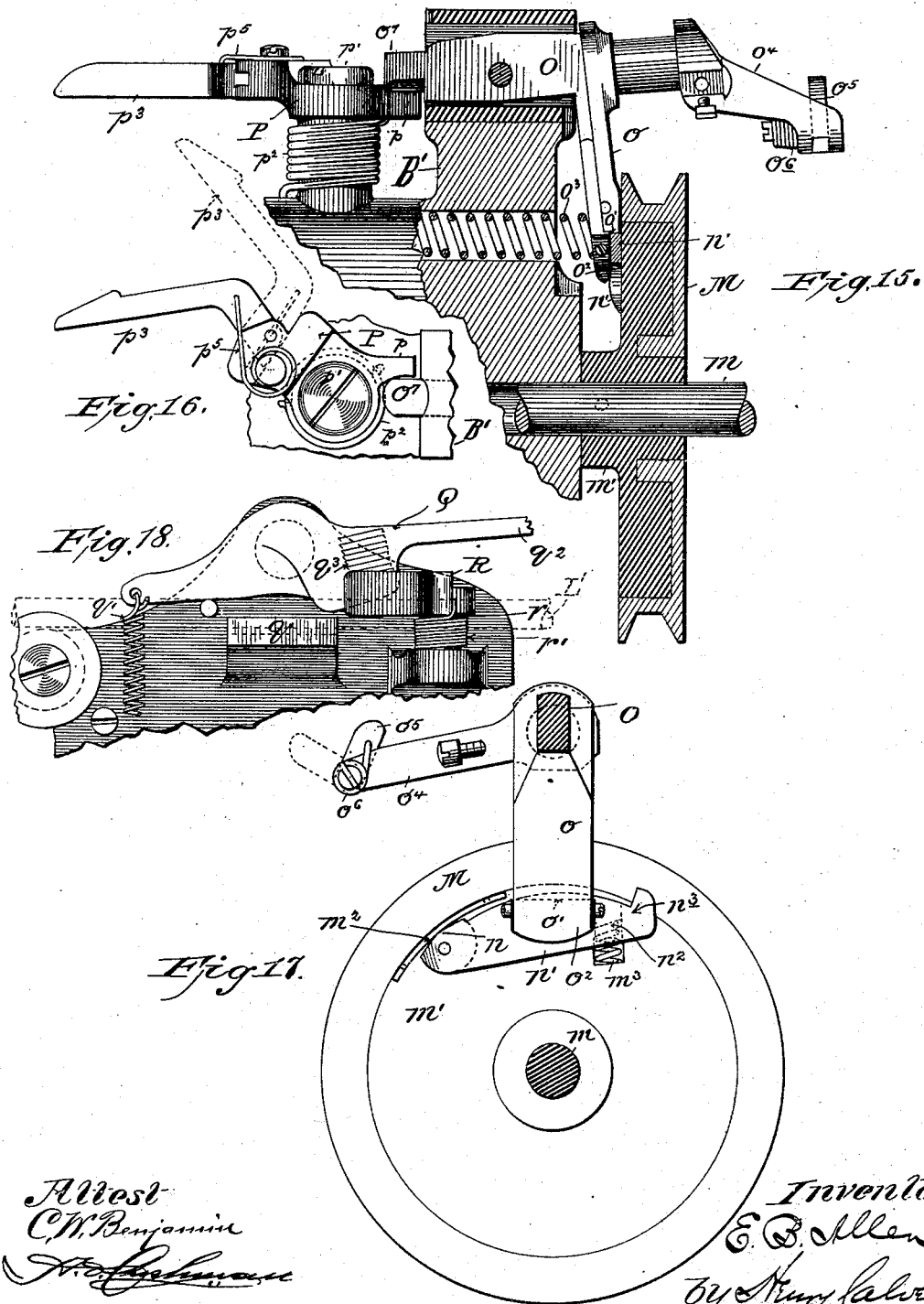

Attest
C. M. Benjamin
J. P. Schuman

Inventor;
E. B. Allen
by *King* *Calvert*
Atty.

UNITED STATES PATENT OFFICE.

EDWARD B. ALLEN, OF ELIZABETH, NEW JERSEY, ASSIGNOR TO THE SINGER
MANUFACTURING COMPANY, OF NEW JERSEY.

CARPET HOLDING AND SEWING APPARATUS.

SPECIFICATION forming part of Letters Patent No. 524,997, dated August 28, 1894.

Application filed January 2, 1894. Serial No. 495,391. (No model.)

To all whom it may concern:

Be it known that I, EDWARD B. ALLEN, a citizen of the United States, residing at Elizabeth, in the county of Union and State of New Jersey, have invented certain new and useful Improvements in Carpet Holding and Sewing Apparatus, of which the following is a specification, reference being had therein to the accompanying drawings.

5 My invention has for its object to provide a convenient apparatus for stretching, holding and sewing long sections of carpets or other heavy fabrics which are to be held in such manner that their edges may be readily
15 evened for the sewing operation and so that patterns or figures of the carpets may be conveniently matched by the operator as the sewing progresses, or so that the fabrics may be stretched, matched and held preparatory to
20 the sewing operation.

To this end my improved apparatus comprises a suitable support which sustains stretching and holding devices or clamps for the fabrics and also a suitable track or guide-
25 way on which a traveling sewing machine, by which the fabric edges are to be united, is to move. The fabric holding devices are preferably so disposed that the carpets or other fabrics to be united will be supported edge-
30 wise vertically so that the different sections thereof may be more easily moved relative to each other, (to even their edges or match the patterns or figures) than would be possible were the fabric sections superposed or laid
35 flatwise horizontally on each other, as in the latter position the weight of the fabrics and the frictional or clinging nature of the contiguous faces of heavy pile fabrics renders the adjustment of one fabric section on another almost impossible, particularly with cut
40 pile fabrics. The fabric holding and stretching devices or clamps are placed at suitable intervals throughout the length of the guide-way or track on which the traveling machine is to run, and the said traveling machine is
45 preferably driven by an endless belt having a clutch or other suitable start and stop-motion connection with the driving shaft of the machine. The traveling movement of the
50 machine relative to the stationarily held fab-

rics is preferably effected by a positive feeding mechanism having a positive engagement with a rail or bar placed parallel to the track or guide-way on which the sewing machine travels. The clamps by which the fabrics to
55 be united are held are preferably of such construction that as the jaws thereof are closed together on the fabrics they will stretch the said fabrics which are grasped between them, to place the fabrics under suitable tension so
60 as to hold their edges taut and smooth, said clamps being thus stretching as well as holding clamps; and, movable with the said clamps, as the latter are closed and opened, are start and stop-motion devices, or what
65 may be termed "governing devices" of such a character that should the traveling sewing machine arrive at the end of a fabric section which has been matched, stretched and clamped, in readiness for the sewing opera-
70 tion, before the next fabric section has been made ready, the machine will be automatically stopped, but will be again set into operation by and simultaneously with the act of closing the clamps of the next fabric section; the start and stop-motion devices movable
75 with the closing and opening clamps co-operating with the start and stop-motion devices of the machine to effect these operations. The adjustment of the fabric edges in pre-
80 paring for the sewing operation is facilitated by stationary guides which determine their height as they are placed in the clamps, and impaling pins carried by pivoted arms movable independently of the clamping arms are
85 provided to assist in the operation of handling the heavy fabrics. The stretching and holding clamps are normally movable independently of each other in opening and closing, but connecting latches, whereby all the clamps
90 of a series may be opened by operating one clamp or clamp section, are provided; thus enabling the finished work to be quickly released. The traveling machine is preferably returned to its starting position by an endless
95 return belt running in a direction opposite to the driving belt, and the latter is preferably so arranged that both the forwardly moving and return sections thereof will run in the same horizontal plane and thus both parts of
100

said belt may be utilized to drive sewing machines in opposite directions at the same time, the tracks or guideways for the machine and the clamping and holding devices for the fabrics, being, to this end, provided in duplicate.

In the accompanying drawings Figure 1 is a partial side elevation of a carpet sewing apparatus embodying my invention. Fig. 2 is a plan view of the same. Figs. 3 and 4 are cross sections on lines 3—3 and 4—4, respectively, of Fig. 2. Fig. 5 is a partial plan view, on an enlarged scale, of the apparatus shown near the lower right hand corner of Fig. 2. Figs. 6 and 7 are detail views of the clamping devices. Fig. 8 is a detail view of the releasing or tripping device for the locking dog of the return belt grip. Figs. 9, 10, 11 and 12 are detail views to show the operation of the releasing latches for the clamps. Fig. 13 is a cross section, on an enlarged scale, on line 13—13, Fig. 2. Fig. 14 is a full plan view of the traveling sewing machine. Figs. 15, 16 and 17 are detail views of the clutch and starting and stopping mechanisms of the said machine, and Fig. 18 is a detail view of the return-belt gripping-device.

In the form in which I have herein illustrated my invention I provide standards A at the upper parts of which are brackets *a* having upper and lower horizontally extending arms which support rods *b* and *b'* which latter form the track or guideway for the traveling sewing machine B, the latter having lower grooved wheels *b²* engaging the lower rod *b* and upper grooved wheels *b³* engaging the upper rod *b'*, the said wheels *b³* being preferably pressed upward by suitable springs placed beneath them so as to have yielding contact with said rod *b'*. C is a rack-bar the teeth of which are engaged by suitable feeding devices of the traveling sewing machine to move the same positively forward intermittingly.

Journalled in the outer ends of the upper arms of the brackets *a* are rods *d* to which the clamping arms E are attached, said arms carrying at their lower ends pivoted clamping and stretching levers *e* provided with jaws *e'* co-operating with similar pivoted, clamping and stretching levers *e²* supported by blocks *a'* at the lower ends of the arms of the said brackets *a* and furnished with jaws *e³*, the said jaws being forced inward or toward each other by springs *e⁴* Fig. 7 acting on said levers. The movements of the levers *e* under the influence of their springs *e⁴* are limited by stop-pins or projections *e⁵* on the arms E engaged by tail pieces *e⁶* on said levers *e*, and the movements of the levers *e²* under the stress of their springs *e⁴* are limited by stops or projections *a²* on the blocks *a'* co-operating with the tail pieces *e⁷* on the said levers *e²*. In closing the clamps the jaws *e* and *e³* of the levers *e* and *e²* are first brought into engagement with the opposite sides of the fabrics which are placed between said jaws and the further downward or closing movements of

the arms E will then turn said levers *e* and *e²* on their pivots thus causing said jaws *e'* and *e³* to move forward somewhat in the direction of the length of the fabrics thereby stretching the latter and drawing them taut. This stretching operation of the clamping jaws will be readily understood by reference to Fig. 7 in which the first grasping and the final stretching and holding positions of the clamp jaws are denoted by full and dotted lines, respectively. The arm E' farthest to the left (Figs. 1 and 2) has a plain or non-stretching clamp-jaw co-operating with a similar plain clamp-jaw on the frame-work of the apparatus, as this first clamp merely holds the ends of the fabrics, and is therefore of any ordinary or suitable construction.

The arms E are operated by hand levers *f* fulcrumed at *f'* to the upper arms of the brackets *a* and connected to the short arms *e⁸* of the arms or levers E by links *f²*, the latter and the inner end portions of the levers *f* forming toggles which are straightened out just before the outer ends of the hand levers *f* are depressed to their lowest positions to close the clamping and stretching jaws together; the center point of a toggle just passing a central longitudinal line drawn through the toggle when said jaws are as fully closed as is desired and when the further descent of the hand lever is arrested by a suitable stop; and as the toggle center is thus just past said central line when the jaws are in clamping position any tendency of the said jaws to open is overcome and the said jaws are locked, as will be understood.

The rods *d* are provided at their ends, opposite to where the arms E are attached, with collars *d'* from which, on the sides of the rods *d* opposite to the arms E, are extended arms *d²* provided with weights or counterpoises D sufficiently heavy to overbalance the arms E and thus hold the jaws of the clamps apart and the clamps open when not in use. The weights D are each provided with a depending lug or projection *d³* arranged to be in the path of a tripping arm on the machine, to stop the latter, should the clamp arm E with which said weight and projection are connected (through rod *d*) not be closed, and each collar *d'* is furnished with a cam *d⁴* arranged to engage a starting and stopping lever on the machine as the clamp with which said cam is connected is closed, and thus the traveling machine, which has been stopped by a lug *d³*, will again be set into operation when the material is ready. Thus the lugs *d³* and cams *d⁴*, co-operating with the stop-and-start-motion devices (to be hereinafter described) of the traveling machine, are what may be termed "governing devices" as they control the movement of the machine in such a manner as to cause it to stop when the material ahead is not ready and to start when such material has been clamped and stretched in readiness for sewing. The collars *d'* are provided with lugs *d⁵* placed beneath the hand levers *f* and

thus serving to arrest the downward or clamping movements of said levers, the said lugs being the stops for said levers hereinbefore mentioned.

5 Pivoted on the rods d are arms g carrying impaling pins g' which, when said arms are in their lowered or closed positions enter holes h formed in the lower arms of brackets h' similar in form to the brackets a and supported by strengthening cross-heads H braced to the standards A by rods h^2 and serving to steady the track or guideway rods b and b' and the rack bar C all of which are attached to said brackets h' . The rods d are provided with collars d^6 having notches d^7 to be entered by hooks or lugs i formed at the upper or inner ends of latches or hand levers i' pivoted to the arms g and beneath which are placed springs i^2 to hold the lugs or hooks i in contact with the collars d^6 or to force said lugs or hooks into said notches d^7 when said arms g are lifted to cause said lugs or hooks to register with said notches. When said lugs or hooks are entered in said notches the arms g will be held elevated with their impaling pins g' withdrawn from the work, even when the clamps are closed, and said arms g will be further lifted to be wholly out of the way when the clamps are opened.

30 Placed closely adjacent to each set of clamping and stretching jaws is a stationary gage j to be engaged by the upper edges of the fabrics and thus determine the height to which the fabrics should be lifted before the clamps are closed on the same. The gages j are so placed as to be outside of the line of movement of the traveling machine B , the fabrics, after being positioned as to height by the said gages, being moved inward to sewing position by clamps as the latter are closed. The gages j are attached to the rod b' , the rods d passing freely through the upper parts thereof.

45 The traveling sewing machine B is preferably driven by an endless belt L receiving movement from any suitable source of power, as from a driving pulley K which may be operated by an electric motor or otherwise, said belt running over pulleys k supported at the opposite ends of the track or guideway on which the machine runs. The driving belt L is preferably so arranged that both the forwardly moving and return sections thereof will run in the same horizontal plane so that both parts of said belt may be utilized to drive sewing machines in opposite directions at the same time, the tracks or guideways for said machines, and the stretching and holding devices for the fabrics being, to this end, provided in duplicate, as shown in the drawings.

60 The endless driving belt L operates a pulley M which, in the present instance has a suitable clutch connection with the main shaft m of the machine B , said clutch connection, as herein shown, being as follows: To the shaft m is secured a wheel m' surmounted by the pulley M , and between said

pulley and said wheel is placed a shoe m^2 acted on by a cam n seated in said wheel and provided with an arm n' having a lug n^2 against which presses a coil spring m^3 to cause the cam n to force said shoe m^2 into holding contact with the pulley M to give the latter a driving engagement with the wheel m' . The endless driving belt L is held in contact with the pulley M by pulleys t beneath which said belt runs.

Pivoted to a post B' forming part of the frame of the machine B is a stopping and starting lever O having a depending arm o at the lower end of which is a shoulder o' to engage the upper edge of the clutch arm n' and turn the cam n slightly, in opposition to the action of the spring m^3 , when the shoe m^2 is to be disengaged from the pulley M to permit the latter to run free; said arm n' having at its end a hook or projection n^3 to engage said arm o and thus positively stop the wheel m' and the main shaft of the machine with which said wheel is connected. The arm o is provided, below the shoulder o' with a brake o^2 having a friction surface of raw hide or other suitable material, to engage the side or face of the clutch arm n' to arrest or slacken the movement of the wheel m' after it has been disengaged from the pulley M and before it is positively stopped by contact of the hook n^3 with the arm o ; thus avoiding any injurious shock by the positive stop. The lever O is tilted, to bring the arm o into contact with the arm n' , by a spring o^3 seated in the post B' and pressing against the said arm o .

The lever O is provided with an arm o^4 rigidly attached thereto and having at its end a projection o^5 to be acted on by any one of the cams d^4 movable with the clamps, the action of the cams d^4 on the arm o^4 being to depress the end of the lever O to which said arm is attached and thus remove the arm o from contact with the arm n' and thereby cause the clutch above described to engage the wheel m' with the pulley M and set the machine in motion. To prevent accidental starting of the machine when the latter is being run idly backward to commence a new seam the lug or projection o^5 is pivoted to the arm o^4 and is yieldingly held in its operative position by a spring o^6 which will permit it to be turned to the position shown in dotted lines in Fig. 17, should any of the clamps not be opened when the machine is running backward, the cams d^4 being in position to be engaged by said lug or projection o^5 only when the clamps, with which cams are connected, are closed.

125 The stopping and starting lever O is provided with a tail piece o^7 beneath which, to hold the arm o of said lever out of engagement with the arm n' of the clutch device, extends a lug p formed on a dog P pivoted on the shank of the screw p' , so as to turn horizontally, and acted on by a torsional spring p^2 to hold said lug p beneath the said tail piece o^7 . The dog P is provided with a trip-

ping arm p^3 so placed as to engage any one of the stopping lugs d^3 on the weights D should the clamp, with which any one of said weights and lugs are connected, not be closed; the engagement of a tripping arm p^3 with a lug d^3 , when the machine is traveling forward, causing the dog P to be turned to remove the lug p from beneath the nail piece o^7 of the lever O, thus leaving said lever free to be moved into position by its spring o^3 to uncouple the clutch and stop the machine. When the dog P is thus tripped the tail piece o^7 of the lever O descends slightly so that the lug p , by engagement with a vertical face of said tail-piece, is held aside in an inoperative position. As the clamps will be open when the machine is to be run backward to its starting point, and as the lugs d^3 will thus be in the path of the tripping arm p^3 , the latter, although so connected with the locking dog P as to move the said dog positively when tripping it to stop the machine, is yieldingly connected with said dog by the spring p^5 so as to move idly to the position shown in dotted lines, Fig. 16, when passing said lugs d^3 on the backward or return movements of the traveling machine.

L' is an endless returning belt running, in a direction opposite to the belt L, over pulleys h' at the opposite ends of the track or guideway on which the traveling machine moves. The said machine is provided with a gripping device to engage the said returning belt so as to be moved therewith, said gripping device, as herein shown, consisting of a grooved block or lug q between which and a gripping lever Q said returning belt runs. A spring q' normally holds the gripping part of the said lever lifted out of contact with the said belt, and when the machine is to be returned the operator depresses the handle end q^2 of the said lever to cause the latter to grip the said belt, said lever being held in gripping position by a toothed locking dog R pivoted on a screw r and forced by a torsional spring r' into engagement with a toothed portion q^3 of said lever Q. When the locking dog R is released from the said lever Q the spring q' releases said lever from the returning belt.

To prevent the machine from overrunning its track or guideway at its return movement I provide, near the starting point of the machine, a releasing device for the locking dog R, said releasing device consisting of an arm r^4 supported by a hanger r^3 and placed in the path of movement of said dog to trip the latter on the return movement of the machine and thus automatically ungrasp the return belt, said arm being yieldingly held by a spring r^5 in such a manner that it will be swung out of the way, when engaged by said dog, on the forward movement of the machine.

In practice my improved fabric stretching and holding apparatus and the track or guideway for the traveling machine are of considerable length and comprise quite a large

number of the stretching and holding clamps which latter are some three and a half feet (more or less) apart, and when a long seam has been completed it is desirable that all of the clamps holding the fabrics which have been sewed may be released by operating a single hand lever f by which the clamps are closed and opened, and thus avoid the delay which would be occasioned were said hand levers all to be separately operated to open the clamps. To thus open all of the clamps by that one of the hand levers f which is at the end of the seam last completed I mount on the collars d' adjacent to the clamp arms E and hand levers f pivoted releasing latches s the upper ends of which are pressed by springs s' toward said levers f and the latter are provided with inclines f^4 preferably formed at the bottoms of notches f^5 formed in said levers, the said latches s being provided near their tops with shoulders s^2 . Thus when a clamp is to be closed by depressing its operating hand lever f and the clamp which is next ahead (or to the right, Fig. 1) is open, (as will always be the case in practice, as the clamps are successively closed from one end of the fabric sections to be sewed to the other) the latch s connected with the open clamp will be in such position (see Figs. 9, 11 and 12) that the incline on the lever f will permit said lever, as the latter is lowered in closing its clamp, to pass by the shouldered portion of the latch s , but when the clamp with which said latch is connected is closed the latch will be turned to the position shown in Fig. 10 to bring its shoulder s^2 beneath the lever f contiguous thereto and which is on the next clamping section and thus engage said latch with said lever so that when the clamp with which the latch is connected is opened the turning movement of the collar d' on which the latch is mounted (and which is connected with the clamp through the rod d) will lift the said latch and cause the latter to raise the lever f with which said latch is now engaged far enough to throw out the toggle, formed by the inner end of said lever and the link f^3 , and thus permit the overbalancing weight D connected with the clamp rod d to entirely open the clamp. As all of the clamps of a series will, when closed, be connected together through the releasing latches s it will be obvious that by raising the operating hand lever of the clamp last closed, to open said clamp, the latch connected with the clamp first released or opened will open the next clamp, and so on successively through the entire series of clamps, running back to the first stretching clamp near the starting point of the machine. With regard to this releasing operation of the clamps it should be borne in mind that the lever f , shown in Figs. 9 and 10, is on a different clamp section from that with which the releasing latch s , shown in said figures, is to be connected, and that the operating lever f with which said releasing latch s is connected is represented by the op-

erating lever farthest to the right at the lower side of Fig. 2, while the operating lever *f*, shown in said Figs. 9 and 10 is represented by the middle one of the operating levers 5 shown at the lower side of Fig. 2. In other words, it should be borne in mind, for a clear understanding of the operation of the releasing latches, that a releasing latch of one clamp section operates to throw up the lever 10 *f* of the next adjoining clamp section, and so on through the entire series of clamps. As it is objectionable (except when a carpet has been entirely sewed by uniting the last two breadths thereof) to permit the heavy fabrics 15 to fall to the floor when the clamps are all opened, as above indicated, owing to the labor which would be required to again lift the heavy fabrics, the arms *g* are lowered to engage their impaling pins *g'* with the fabrics 20 before the clamps are opened, said pins thus holding the fabrics from falling.

The traveling sewing machine B has an intermittent feeding movement on its track or guide-way, this feeding movement being effected by suitable feeding and holding devices engaging the teeth of the rack-bar C. This feeding mechanism is fully set forth in my application, Serial No. 495,390, filed January 2, 1894, simultaneously herewith, and therefore need not be further described herein. 30

In the use of my invention and with the endless driving belt L running in the direction denoted by the arrows in Figs. 1 and 2, 35 if the front track or guideway shown at the lower side of Fig. 2 be in use, the traveling sewing machine will be placed at the left hand end of the said track or guide-way with the projection *o*⁵ on the arm *o*⁴ of the starting and stopping lever O beneath the cam *d*⁴ farthest 40 to the left. The fabrics (the ends of which are held by the non-stretching first clamp after the clamp arm E' has been lowered) are now adjusted to proper position and the clamp arm E farthest to the left is lowered, closing the first set of stretching and holding clamps and drawing taut the fabrics extending from the end holding clamp to the stretching clamp 45 first closed. The operation of closing the first stretching clamp, and which thus makes a fabric section ready for sewing, causes the cam *d*⁴ to act on the said projection *o*⁵ on the arm *o*⁴ of the starting and stopping lever O, thus withdrawing the stopping arm *o* of said 50 lever from the clutch arm *n'* and permitting the clutch to engage the wheel *m'* with the driving pulley M, and thus start the machine, the said pulley, it being understood, running continuously with the driving belt L. When the traveling machine arrives at the end of the clamped and stretched fabrics if the next set of clamps be not closed the stopping lug *d*³, 55 connected with the open clamp, will be in the path of the tripping arm *p*³ of the locking dog P, and the engagement of said arm with said stopping lug *d*³ will cause the locking lug *p* of said dog to be withdrawn from beneath the

tail-piece *o*⁷ of the lever O, thus permitting the latter to be tilted by its spring *o*³ to uncouple the clutch and stop the machine, the 70 said machine being again set into operation by a cam *d*⁴, when the next stretching clamp is closed, as above described. Should all of the clamps of a series be closed, or, in other words, should lengths of carpet sections to 75 be united be matched, stretched and clamped, before the machine is started, of course the entire lengths will be sewed without stopping the machine; and the sewing operation of carpet sections extending the full length of 80 the holding and stretching apparatus and of the track or guideway will also be continuous if the clamps be successively closed, as the machine advances, before the machine reaches the respective governing devices represented 85 by the stopping lugs *d*³ and starting cams *d*⁴ which are placed opposite to each other, these governing devices, it being understood, being for the purpose of preventing the machine from running into unclamped and unpre- 90 pared fabric sections; and also to provide for starting the machine simultaneously with the operation of closing the clamps, without requiring any special care on the part of the operator who has only to attend to adjusting 95 and clamping the fabrics. The edges of the carpets are held above the clamps, and the arms E of the latter are curved outward, and the traveling machine can thus move freely past said arms and clamps without interfer- 100 ence therewith, a suitable guide on the traveling machine bringing the edges of the fabrics in proper position relative to the needle of the machine and holding said edges during the sewing operation. 105

Having thus described my invention, I claim and desire to secure by Letters Patent—

1. The combination with a track or guideway and a traveling sewing machine to run 110 thereon and provided with a stop-motion device, of clamps disposed along said track or guideway and serving to hold the fabrics to be sewed by said machine, and stopping devices movable with said clamps and so ar- 115 ranged as to be brought into position to stop the machine when the clamps are open but to be in such position as not to interfere with the machine when the clamps are closed.

2. The combination with a track or guide- 120 way and a traveling sewing machine to run thereon and provided with start and stop-motion devices, of clamps for holding the fabrics to be sewed by said machine, and starting and stopping or governing devices mov- 125 able with said clamps and co-operating with the start and stop motion devices of the machine: whereby the latter will be set into operation when a clamp is closed or will be stopped by a governing device if the clamp 130 with which the latter is connected be open.

3. The combination with a track or guideway and a traveling sewing machine to run thereon and provided with a pulley having a

- clutch connection with the driving shaft of the machine, starting and stopping devices to operate said clutch and to connect and disconnect said pulley and shaft, clamps to hold the fabrics to be sewed, and starting and stopping or governing devices movable with said clamps and serving, according to the closed or open positions of the clamps, to govern the action of the starting, stopping and clutch mechanisms of the said machine.
4. The combination with a track or guideway and a traveling sewing machine to run thereon, of an endless driving belt for moving the machine forward, means for operatively connecting said belt with the driving shaft of the machine, to set the latter into operation, an independent endless returning belt for running the machine back to its starting position, and a gripping device on the machine for engaging the latter with the said returning belt.
5. The combination with a track or guideway and a traveling sewing machine to run thereon, of an endless driving belt for moving the machine forward, means for operatively connecting said belt with the driving shaft of the machine to set the latter into operation, an independent endless returning belt for running the machine back to its starting position, a gripping device on the machine for engaging the latter with the said returning belt, and a releasing device, placed near the starting point of the machine, for disengaging said gripping device from said returning belt.
6. The combination with a track or guideway and a traveling sewing machine to run thereon, of a fabric-holding apparatus comprising means for holding one end of the fabrics and one or more clamps each of which consists of two opposing spring-pressed jaws which, after having been brought into engagement with the opposite sides of the fabrics, in closing, are constructed and arranged to have a horizontal or forward movement to stretch the fabrics longitudinally, and means for closing the clamps against the fabrics.
7. The combination with a track or guideway and a traveling sewing machine to run thereon, of a series of independent, combined stretching and holding clamps disposed along said track or guideway and each clamp having opposing spring-pressed jaws to engage the opposite sides of the fabrics to be united by said machine, each of said independent clamps being adapted to be opened and closed without disturbing the others.
8. The combination with a track or guideway and a traveling sewing machine adapted to run thereon, of a series of clamps arranged to hold the fabrics to be sewed parallel with the said track or guideway, each of said clamps comprising a spring-pressed clamp arm or lever pivoted to a stationary support and provided with a clamping jaw, and a spring-pressed clamp arm or lever pivoted to a movable support or carrying arm and also provided with a clamping jaw, the jaw-portions of said clamp arms being yieldingly pressed toward each other by their springs, so that when said jaws are forced against the opposite sides of the fabrics, in clamping, they will have horizontal or forward movements to stretch the fabrics longitudinally.
9. The combination with a track or guideway and a traveling sewing machine adapted to run thereon, of supporting brackets forming part of the stationary framework of the said track or guideway, clamp-arms or jaws sustained by said brackets, rods journaled in said brackets and provided with arms carrying clamp-arms or jaws co-operating with the said first-named clamp arms or jaws, operating levers pivoted to said brackets, and links arranged in connection with said operating levers to form toggles which straighten out as the clamp-jaws are closed together.
10. The combination with a track or guideway and a traveling sewing machine to run thereon, of a fabric-holding apparatus comprising a series of clamps disposed along said track or guideway, said clamps being independent of each other, and being thus adapted to be successively closed on the fabrics, arms or levers by means of which said clamps may be opened, and releasing devices or latches by which said arms or levers may be operated to open the clamps, when desired, said releasing devices or latches serving, when the last clamp of the series of clamps is opened, to successively open the preceding clamps of the series.
11. A fabric holding apparatus comprising a series of clamps, combined with impaling pins for assisting in handling the fabrics, and pivoted arms, movable independently of the clamps, by which said pins are carried.
12. A fabric holding apparatus comprising a series of clamps, combined with impaling pins for assisting in handling the fabrics, pivoted arms, movable independently of the clamps, by which said pins are carried, and means for connecting said arms with said clamps, so that, when desired, the said arms may be raised, to lift said pins, when the clamps are opened.
13. The combination with a track or guideway and a traveling sewing machine to run thereon, said sewing machine being provided with a stop-motion device, of clamps comprising the movable clamp-carrying arms E, the rods d, by which said arms are carried, and stopping devices, as lugs d², movable with said rods and clamp-carrying arms, said stopping devices being so constructed and arranged as to be in the path of movement of some portion of the said stop-motion device of the machine when the clamps are open, but to be in such position as not to operate the stop-motion device when the clamps are closed.
14. The combination with a track or guideway and a traveling sewing machine to run thereon, and provided with start and stop-motion devices, of clamps comprising the mov-

able clamp-carrying arms E, the rods d by which said arms are carried, starting devices, as cams d^4 , and stopping devices, as lugs d^3 , movable with said rods and arms, and so arranged relative to the start and stop motion devices of the machine as to stop the machine if the clamps be open, and to start the machine when the clamps are closed.

15. The combination with a track or guideway and a traveling sewing machine to run thereon, of clamps comprising the clamp-carrying arms E, the rods d by which said arms are carried, the lugs d^3 and the cams d^4 movable with said rods and arms, the stopping and starting lever O having an arm a part of which is arranged to be engaged by a cam d^4 to start the machine, and the dog P serving to lock the said starting and stopping lever in an inoperative position when the machine is in operation, said dog having a tripping arm p^3 to be engaged by one of the said lugs d^3 when a clamp is open, and the machine is to be stopped.

16. The combination with the traveling sewing machine having the driving shaft m , of the wheel m' fixed to said shaft, the driving pulley M loose relative to said shaft, the shoe m^2 interposed between said wheel and pulley, the clutch cam n seated in said wheel and having a spring-pressed arm by which it is caused to act on said shoe to couple the said pulley M with the said wheel m' , when desired, and a starting and stopping lever O having a spring-pressed arm o to disengage the said clutch devices, and having also the tail-piece o^7 and the arm o^4 which latter, when pressed upon, will permit the clutch to act to couple the driving pulley M with the said wheel m' , and the spring-pressed locking dog P having a lug p arranged to engage said tail-piece o^7 , to hold the said arm o out of engagement with the clutch devices.

17. The combination with the traveling sewing machine having the driving shaft m , of the wheel m' fixed to said shaft, the driving pulley M loose relative to said shaft, the shoe m^2 interposed between said wheel and pulley, the clutch cam n seated in said wheel and having a spring-pressed arm by which it is caused to act upon the said shoe to couple the said wheel with the said pulley, the starting and stopping lever O provided with the arm o having a shoulder o^7 to engage the edge of the said spring-pressed arm, and thus release the said shoe from binding contact with the said pulley, said arm o having also a brake portion to bear against the face of the spring-pressed clutch arm to arrest the movement of the said wheel m' , the spring o^3 for operating said starting and stopping lever in one direction, the locking dog P to hold the said lever O in an inoperative position when the machine is running, and the arm o^4 carried by the said lever O and which, when pressed upon, releases the arm o from the clutch and permits the latter to act to start the machine.

18. The combination with the traveling sewing

machine having the driving shaft m , of the wheel m' fixed to said shaft, the driving pulley M loose relative to said shaft, the shoe m^2 interposed between said wheel and pulley, the clutch cam n seated in said wheel and having a spring-pressed arm by which it is caused to act upon the said shoe to couple the said wheel with the said pulley, the starting and stopping lever O provided with the arm o having a shoulder o^7 to engage the edge of the said spring-pressed clutch arm, and thus release the said shoe from binding contact with the said pulley, said arm o having also a brake portion to bear against the face of the spring-pressed clutch arm to arrest the movement of the said wheel m' , the spring o^3 for operating said starting and stopping lever in one direction, the locking dog P to hold the said lever O in an inoperative position when the machine is running, and the arm o^4 carried by the said lever O and which, when pressed upon, releases the arm o from the clutch and permits the latter to start the machine, said arm o^4 being provided with a spring-pressed pivoted lug or projection o^5 which is adapted to yield in one direction so that the machine will not be set into operation when being returned to its starting position.

19. The combination with a track or guideway and a traveling sewing machine to run thereon and provided with a starting and stopping lever, of a locking dog by which the said starting and stopping lever is held in an inoperative position when the machine is running, but which is provided with a tripping arm to release the said lever when the machine is to be stopped, said tripping arm having positive connection with said dog in one direction but being yieldingly connected with the said dog so that it may be moved freely in an opposite direction, when the machine is running backward to be returned to its starting position, without operating said dog.

20. The combination with a track or guideway and a traveling sewing machine to run thereon, of an endless driving belt for moving the machine forward, means for operatively connecting said belt with the driving pulley of the machine, to set the latter in operation, an independent endless returning belt for running the machine backward to its starting position, and a gripping device for the said returning belt consisting of the block q on the machine and the lever Q having a gripping portion to engage the said returning belt and force it against the said block q , and a spring-pressed locking dog R for holding the said lever Q in gripping position.

21. The combination with a track or guideway and a traveling sewing machine to run thereon, of an endless driving belt for moving the machine forward, means for operatively connecting said belt with the driving pulley of the machine, to set the latter in operation, an independent endless returning belt for running the machine backward to its starting position, and a gripping device for the

said returning belt, said gripping device consisting of the block *q* on the machine and the lever *Q* having a gripping portion to engage the said returning belt and force it against the said block *q*, a spring pressed locking dog *R* for holding the said lever *Q* in gripping position, and a releasing device for the said locking dog, said releasing device being placed near the starting point of the machine.

22. The combination with a track or guideway and a traveling sewing machine to run thereon, of an endless driving belt for moving the machine forward, means for operatively connecting said belt with the driving pulley of the machine, to set the latter in operation, an endless driving belt for running the machine backward to its starting position, and a gripping device for the said returning belt, said gripping device consisting of the block *q* on the machine and the lever *Q* having a gripping portion to engage the said returning belt and force it against the said block *q*, a spring-pressed locking dog *R* for holding the said lever *Q* in gripping position, and a releasing device for the said locking dog, said releasing device being placed near the starting point of the machine, and consisting of a spring-pressed arm *r*⁴ and the hanger *r*³ by which said arm is carried.

23. An apparatus for holding fabrics to be sewed by a traveling sewing machine and comprising a series of clamps each composed of a spring-pressed pivot lever, as *e*², supported by a stationary part of the apparatus, and a swinging arm *E* carrying a spring-pressed pivoted lever, as *e*, said levers being provided at their outer or free ends with gripping jaws.

24. The combination with a track or guideway and a traveling sewing machine to run thereon, of a fabric holding apparatus comprising the pivoted rods *d* provided with arms *E* carrying spring-pressed clamp levers *e*, spring-pressed clamp-levers *e*², supported by stationary parts of the apparatus, to cooperate with the said levers *e* and hold the fabrics, the arms *e*³ movable with the said arms *E* and rods *d*, the operating levers *f* and the links *f*² connecting the said levers with the said arms *e*³.

25. In a fabric clamping and holding apparatus the combination with the rods *d* and the

clamp-carrying arms *L* movable therewith, of the arms *d*² rigidly attached to said rods and provided with counterbalancing weights *D* serving to throw out the said clamp-carrying arms *E* when the latter are released.

26. In a fabric clamping and holding apparatus the combination with the rods *d* and the clamp-carrying arms *E* supported thereby and movable therewith, of the arms *g* carrying the impaling pins *g*¹ and pivoted on said rods *d*, and means for connecting said arms *g* with the said rods when desired.

27. In a fabric clamping and holding apparatus the combination with the rods *d* and the clamp-carrying arms *E* supported thereby and movable therewith, of the arms *g* pivoted on said rods and provided with impaling pins *g*¹, the notched collars *d*⁶ attached to said rods, and the spring-pressed locking levers *i*¹ having lugs or hooks *i* to engage said notched collars and thus connect said arms *g* with the said rods, when desired.

28. The combination with the clamps comprising the swinging arms *E* carrying suitable clamping devices and co-operating clamping devices on a stationary part of the apparatus, of the levers *f* by which said arms *E* are operated to open or close the clamps, connections between said arms and levers and spring-pressed releasing latches *s* movable with the said arms *E* and arranged to engage the said levers *f* and lift the latter to open the clamps.

29. The combination with the rods *d* provided with the arms *E* and the collars *d*⁷, of the levers *f* connected with the said arms *E* and provided with inclines *f*⁵, clamps which are closed and opened by the movements of said levers, spring-pressed releasing latches *s* mounted on said collars and having shoulders *s*² to engage the said levers *f*, said shoulders being overridden by the inclines on the said levers *f* when the latter are brought down to close the clamps, but being brought beneath the said levers, to be in position to lift the latter, as the succeeding clamps of the series are successively closed.

In testimony whereof I affix my signature in presence of two witnesses.

EDWARD B. ALLEN.

Witnesses:

HENRY CALVER,
J. F. JAQUITH.