

No. 646,722.

Patented Apr. 3, 1900.

J. A. BARHYDT.
FLUE CUTTER.

(Application filed May 6, 1898.)

(No Model.)

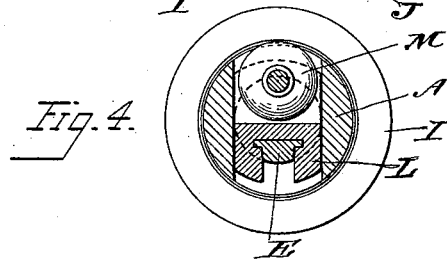
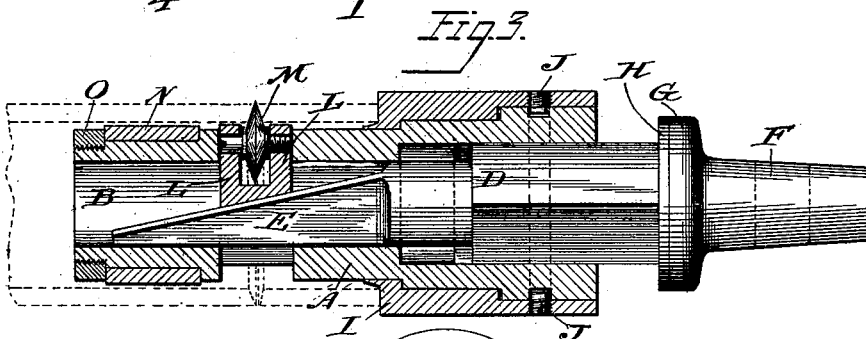
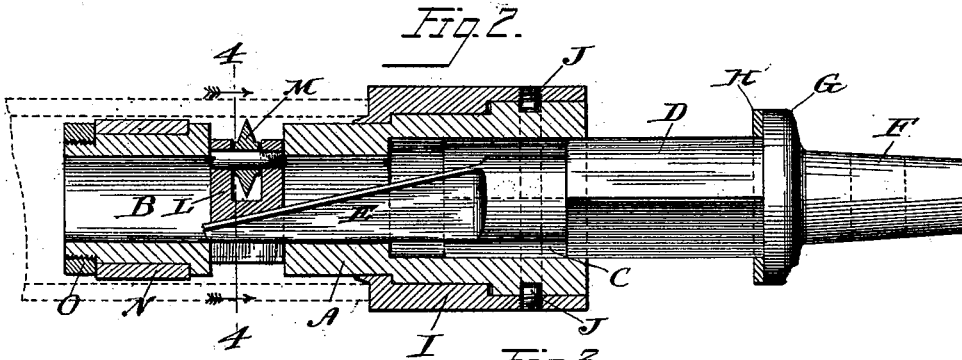
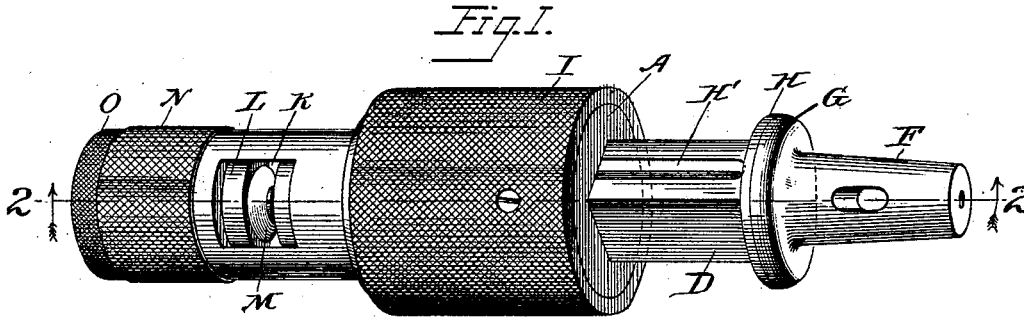

Witnesses
Martin H. Olsew.
Wm. J. Huming

Inventor
James A. Barhydt
by Edward Reeta
his atty

UNITED STATES PATENT OFFICE.

JAMES A. BARHYDT, OF ROCHESTER, NEW YORK.

FLUE-CUTTER.

SPECIFICATION forming part of Letters Patent No. 646,722, dated April 3, 1900.

Application filed May 6, 1898. Serial No. 679,884. (No model.)

To all whom it may concern:

Be it known that I, JAMES A. BARHYDT, a citizen of the United States, residing at Rochester, in the county of Monroe, in the State of New York, have invented a certain new and useful Improvement in Flue-Cutters, of which the following is a description, reference being had to the accompanying drawings, forming part of this specification.

My novel flue-cutter has been chiefly designed for cutting off the tips of the flues of locomotive-boilers, but may be used for other purposes, as will be understood from the explanation of it hereinafter given.

My invention has for its object the provision of a simple, compact, and efficient power-driven cutter by which the tips of flues may be rapidly severed from the bodies of the flues, and its novelty will be hereinafter set forth, and particularly pointed out in the claims.

In the accompanying drawings, Figure 1 is a perspective view of my new cutter; Fig. 2, a vertical longitudinal section of the same in the plane indicated by the dotted line 2 2 of Fig. 1 and with the cutter retracted preparatory to beginning the cutting operation; Fig. 3, a corresponding view with the cutter forced outward to sever the tip from the flue, and Fig. 4 a vertical cross-section on the line 4 4 of Fig. 2.

The same letters of reference are used to indicate the corresponding parts in the several views.

My novel cutter, as shown in the accompanying drawings, is adapted to be operated by any suitable power-driven device for the purpose—as, for instance, by that shown in Patent No. 564,139, issued to me on July 14, 1896, for a machine for operating flue-expanders—such machine being also adapted for the operation of flue-cutters.

In the accompanying drawings, A represents the cylindrical body of the tool, which is provided in the present instance with a forward cylindrical chamber B and a larger rear chamber C, which is in the present instance square in cross-section. Adapted to slide back and forth within the cylinder A is a stock or spindle D, which has a middle rectangular portion adapted to fit within the chamber C of the cylinder A and a forward

wedge portion E, adapted to travel back and forth in the forward chamber B of the cylinder and cooperate with the cutter in the manner hereinafter described. The rear end of the spindle or stock D consists of a tapering shank F, adapted to be inserted in the chuck or holding device of the power apparatus by which the tool is driven. Between the parts D and F the spindle is provided with a flange or collar G, the contact of which with the rear end of the cylinder A limits the forward movement of the spindle. A washer H is fitted over the spindle immediately in front of the collar G and interposes between the collar and the rear end of the cylinder A when the spindle is moved forward to its limit of movement. By providing a considerable number of these washers and placing more or less of them upon the spindle the limit of forward movement of the latter may be regulated, as desired. The square middle portion of the spindle D is provided upon one side with a longitudinal groove H', in which fits one end of a screw (not shown) passed through the cylinder A near its extreme rearward end, the engagement of which screw with the extreme forward end of the groove H' serves to limit the rearward movement of the spindle D and prevent its being entirely withdrawn from the cylinder A.

The rear end of the cylinder A is surrounded by a sleeve I, having a milled exterior surface to facilitate its being grasped by hand, such sleeve constituting the holding-piece of the tool. It is connected with the cylinder A by screws J J, passing through the sleeve I, and fitting in a circumferential groove in the cylinder A, the result of which connection is that while the cylinder A is free to turn within the sleeve I it cannot move longitudinally independently thereof. Within the sleeve I the cylinder A is in the present instance provided with two forwardly-facing annular shoulders, against which about two corresponding rearwardly-facing shoulders upon the inner surface of the sleeve, the purpose of which shoulders is to prevent rearward movement of the sleeve upon the cylinder when the front end of the sleeve is subjected to pressure in the operation of the tool, as hereinafter described.

The cylinder A is provided about midway

of the length of its forward chamber B with a transverse recess K, in which is fitted a sliding block L, in which is journaled the hardened cutting-disk M, the block L constituting the movable support or carrier for said cutter. At its under side, Figs. 2 to 4, the block L is provided with a recess shaped to receive and fit the wedge E, constituting the forward end of the spindle D. This wedge E is in the present instance provided upon its upper side with a projecting flange fitting in corresponding grooves in the walls of the recess in the block L, so that not only will the forward movement of the spindle and wedge serve to force the block and cutter outward, but their rearward movement will serve to positively draw the block and cutter inward.

Forward of the cutter the cylinder A is surrounded by a short sleeve N, having a milled exterior surface, and held in place upon the cylinder by a nut O. This sleeve is free to turn upon the cylinder A, and its exterior fits the interior of the tube and serves to support the forward end of the cutter centrally in the tube as the cutter is turned therein.

The operation of the tool under the above-described construction is as follows: The parts of the tool being in the position shown in Figs. 1 and 2 its forward end is inserted into the end of the flue whose tip is to be removed until the end of the flue abuts against the front end of the sleeve I, as indicated by the dotted lines representing the flue in Fig. 2. Then with the flue held firmly in fixed position the spindle of the tool is pressed forward and rapidly rotated by means of the power-driven device heretofore referred to. The forward pressure upon the spindle will cause its wedge to press the block L outward and force the edge of the cutting-disk M into contact with the inner surface of the flue, and it will be rapidly rolled around the inner surface of the flue and pressed against it upon the same line until it cuts through the flue and severs the tip therefrom, as indicated by the dotted lines of the flue and the position of the parts in Fig. 3.

Having thus fully described my invention, I claim—

1. In a flue-cutter the combination with a cylinder having forwardly-facing shoulders on its exterior, a radially-movable cutting-tool in the cylinder, a driving-spindle longitudinally movable in the cylinder having provisions for moving the tool out, and a sleeve

loosely mounted and secured against the longitudinal movement on the cylinder and having interior shoulders corresponding with the shoulders on the cylinder.

2. In a flue-cutter, the combination of a rotatable cylinder carrying a radially-movable cutter, a non-rotatable sleeve loosely encircling said cylinder in rear of the cutter and having its forward end adapted to form an abutment for the end of the flue, and a driving-spindle fitting within the cylinder and adapted to rotate the same and to force the cutter outward as the spindle is pressed forward.

3. In a flue-cutter, the combination of a rotatable cylinder, a transversely-movable block or carrier fitting in a recess therein, a cutting-disk mounted in said block or carrier, a non-rotatable sleeve loosely encircling the cylinder in rear of the cutting-disk and adapted to form an abutment for the end of the flue, and a driving-spindle fitting within the cylinder and adapted to rotate the same and to force the block or carrier outward and press the cutting-disk into contact with the flue as the spindle is moved forward.

4. The herein-described flue-cutter, composed of the cylinder A, the block L mounted in a transverse recess therein, the cutting-disk M mounted in the block L, the sleeve I encircling the cylinder A, and the spindle D turning with the cylinder A and having at its forward end the wedge E cooperating with the block L, and at its rear end the shank F adapted to be held in the chuck of the power-driven device.

5. The herein-described flue-cutter, composed of the cylinder A, the block L fitting in a transverse recess therein, the cutting-disk M mounted in the block L, the sleeve I fitting around the cylinder A and connected thereto by the screws J fitting the circumferential groove in said cylinder, and the spindle D having the rectangular middle portion adapted to fit and travel in the chamber C of the cylinder, and the forward wedge portion E adapted to travel in the chamber B thereof and cooperate with the block L, and provided at its rear end with the flange G and shank F.

JAMES A. BARHYDT.

Witnesses:

IRVING PAINE,
J. C. YEAGER.