

No. 649,505.

Patented May 15, 1900.

H. BITNER.  
ELEVATOR DOOR.

(Application filed Sept. 14, 1899.)

(No Model.)

2 Sheets—Sheet 1.

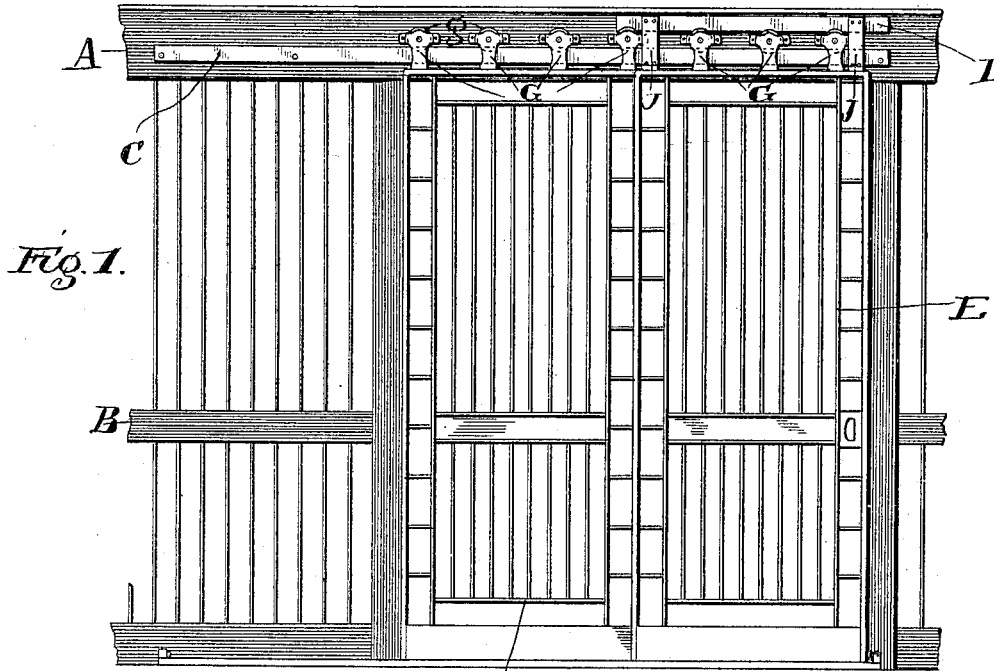

Fig. 1.

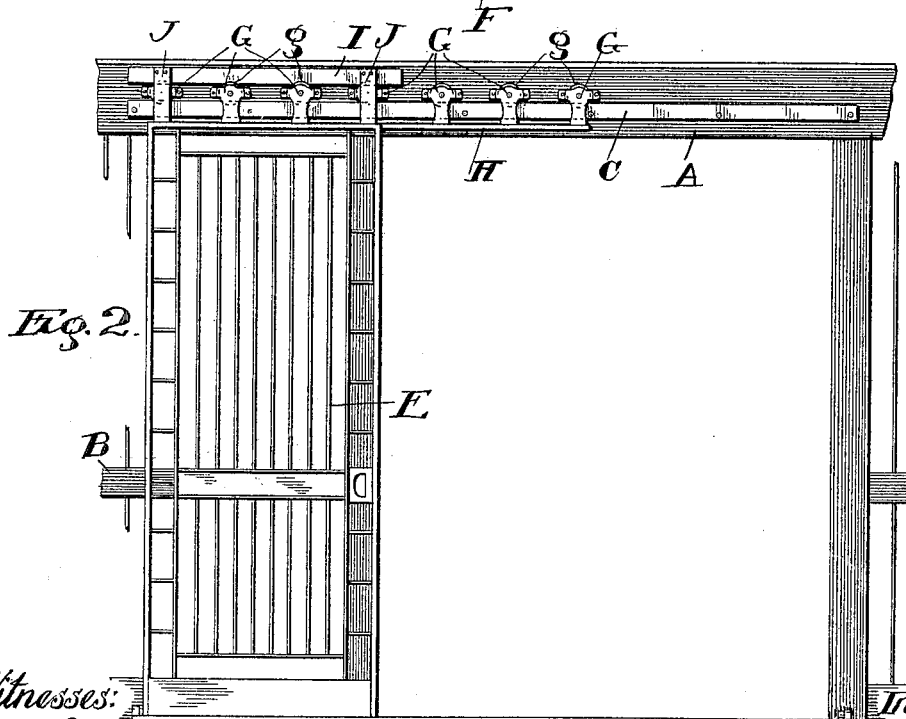

Fig. 2.

Witnesses:

*D. Bliss*  
*Chas. O. Shewey*

Inventor.

*Harry Bitner*  
by *Millie Irvine Bitner*  
Attys.

H. BITNER.  
ELEVATOR DOOR.

(Application filed Sept. 14, 1899.)

(No Model.)

2 Sheets—Sheet 2.

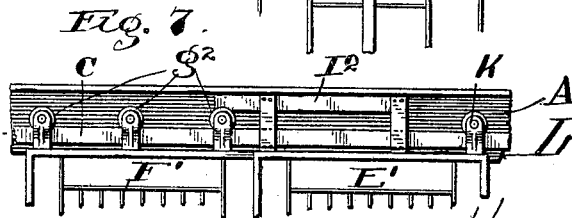
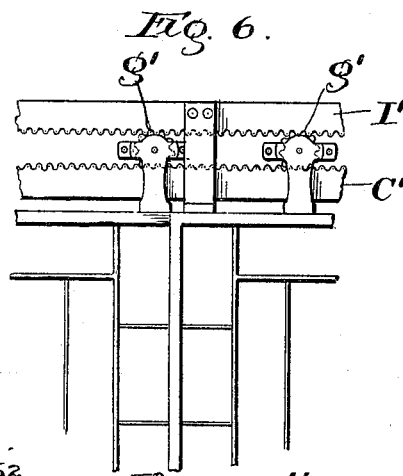
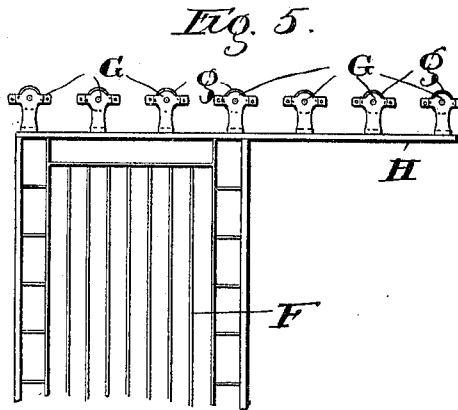
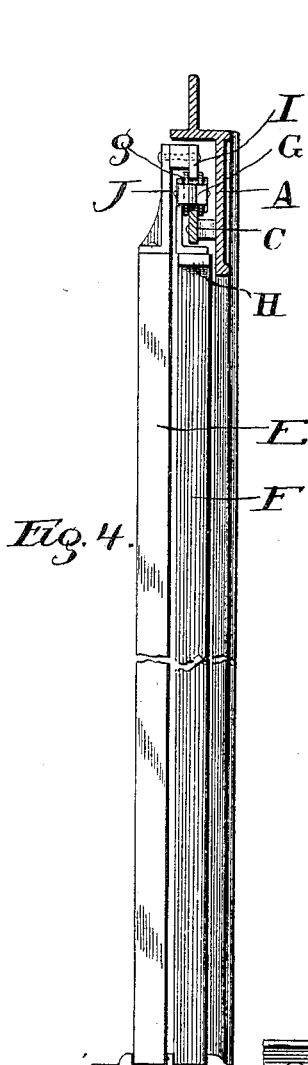
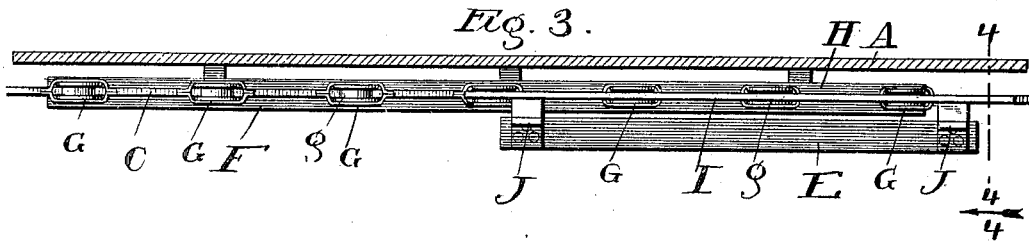

Witnesses:  
 A. Bliss.  
 Chas. O. Shervey

Inventor:  
 Harry Bitner  
 by Messrs. Bitner & Bitner  
 Atty's.

# UNITED STATES PATENT OFFICE.

HARRY BITNER, OF BERWYN, ILLINOIS.

## ELEVATOR-DOOR.

SPECIFICATION forming part of Letters Patent No. 649,505, dated May 15, 1900.

Application filed September 14, 1899. Serial No. 730,398. (No model.)

*To all whom it may concern:*

Be it known that I, HARRY BITNER, a citizen of the United States of America, residing at Berwyn, in the county of Cook and State of Illinois, have invented certain new and useful Improvements in Elevator-Doors, of which the following is a specification.

My invention relates to certain improvements in elevator-doors, the object of which is to mount two parallel doors upon a single track and to time the movements of the doors so that one may move twice as fast as the other. By this means two doors may be arranged to close a given space when shut and to lie one alongside of the other at one side of the space when open.

The invention consists in certain novel characteristics in the hanging of the doors, which will be fully described and claimed.

In the drawings, Figure 1 is a side elevation of a pair of doors and a portion of the inclosure looking from the inside and showing the hangers, the doors being in the closed position. Fig. 2 is a similar view with the doors open. Fig. 3 is a plan with the top of the beam to which the track is secured cut away to show the tops of the hangers, the parts being shown upon a larger scale than the former figures. Fig. 4 is a transverse vertical section in line 4 4 of Fig. 3 looking in the direction of the arrow 4, also upon the same scale as Fig. 3. Fig. 5 is a detail side elevation of one of the doors and hangers, and Figs. 6 and 7 are details of possible modifications.

In the figures, A is the beam spanning the top of the doorway, and B the stationary part of the inclosure containing the latter. A single track C is secured to the beam A in the ordinary manner, and two doors E F are hung upon this track, the doors being of the proper width to close the doorway when extended. The doors open from right to left, the door F traveling its own width to bring it behind the stationary part of the inclosure, and the door E traveling the combined width of itself and the door F to bring it alongside of the latter and also behind the stationary part of the inclosure. To accomplish this the door F is hung upon the track C by means of ordinary hangers G, in which are journaled the common grooved wheels *g*. An extension to the right, H, is formed upon the top of the door and provided with additional hangers and wheels or rollers, a sufficient number of hangers being employed to furnish a contin-

uous support for a bar I, secured by means of straps J to the door E. The bar I rests upon the tops of the wheels or rollers *g*, and said bar is moved by the rotation of the rollers, or vice versa. As these rollers travel upon the track C their tops travel in the same direction as their axles and with double the speed, so that if the door E be moved from its closed position, as seen in Fig. 1, to its open position, as seen in Fig. 2, the door F will travel just half as far and reach a position behind the door E at the same time that the latter is fully opened.

If it should be necessary in any particular use to do so, the track C and the bar I may be made in the form of racks with teeth along the surfaces which roll upon the hanger-wheels, as seen at I', Fig. 6, and the peripheries of the wheels may be toothed to engage with said racks, as seen at *g'* in the same figure. This construction will absolutely prevent slipping and may be found of advantage in some cases.

In the modification shown in Fig. 7 the door E' has a single hanger K to carry the right-hand edge of the door, the left-hand edge being carried by a short bar I<sup>2</sup>, running upon the rollers *g*<sup>2</sup> of the door F'.

I claim as new and desire to secure by Letters Patent—

1. The combination with a relatively-stationary track, of a pair of doors arranged to slide in parallel planes and one alongside of the other, a roller mounted upon one of said doors, upon an axis fixed with relation to said stationary track and a second track secured to the other door and adapted to travel upon the opposite side of the periphery of said roller; substantially as described.

2. The combination with a track and pair of doors hung in parallel planes to slide one alongside of the other, of hangers secured to one of said doors containing rollers adapted to run upon said track and a bar secured to the other of said doors and adapted to run upon said rollers; substantially as described.

In witness whereof I have hereunto set my hand, at Chicago, in the county of Cook and State of Illinois, this 31st day of August, A. D. 1899.

HARRY BITNER.

Witnesses:

CHAS. O. SHERVEY,  
S. BLISS.