



US0D1076727S

(12) **United States Design Patent**  
**Wang**

(10) **Patent No.:** **US D1,076,727 S**

(45) **Date of Patent:** **\*\* May 27, 2025**

(54) **ELECTRIC BICYCLE**

(71) Applicant: **G-Force Inc**

(72) Inventor: **Xin Wang**, Xuzhou (CN)

(73) Assignee: **G-Force Inc**

(\*\*) Term: **15 Years**

(21) Appl. No.: **29/962,843**

(22) Filed: **Sep. 13, 2024**

**Related U.S. Application Data**

(63) Continuation-in-part of application No. 29/874,481, filed on Apr. 20, 2023, now Pat. No. Des. 1,051,777.

(51) **LOC (15) Cl.** ..... **12-11**

(52) **U.S. Cl.**  
USPC ..... **D12/111**

(58) **Field of Classification Search**  
USPC ..... D12/110, 111, 114, 115, 117; D21/412, D21/414, 419, 423, 425, 426, 427, 431, D21/432

CPC ... B62K 3/00; B62K 3/02; B62K 3/04; B62K 3/06; B62K 3/08; B62K 7/00; B62K 7/02; B62K 11/00; B62K 11/02; B62K 11/04; B62K 11/10; B62K 15/00; B62K 17/00; B62K 19/00; B62K 25/02; B62K 25/04; B62K 2202/00

See application file for complete search history.

(56) **References Cited**

**U.S. PATENT DOCUMENTS**

D925,405 S *	7/2021	Lin	.....	D12/111
D960,769 S *	8/2022	Chen	.....	D12/111
D981,914 S *	3/2023	Xiong	.....	D12/111
D984,322 S *	4/2023	Xiong	.....	D12/111
D988,937 S *	6/2023	Knapp	.....	D12/111

D991,099 S *	7/2023	Chen	.....	D12/111
D1,008,882 S *	12/2023	Yang	.....	D12/111
D1,008,884 S *	12/2023	Yang	.....	D12/111
D1,049,936 S *	11/2024	Xiong	.....	D12/111
D1,051,777 S *	11/2024	Wang	.....	D12/111
D1,051,779 S *	11/2024	Li	.....	D12/111
D1,063,713 S *	2/2025	Ye	.....	D12/111
D1,067,831 S *	3/2025	Jia	.....	D12/111

**OTHER PUBLICATIONS**

G-Force DE-S Assembly Instructions, March 20, 2025, YouTube Webpage[online], [Site Visit Mar. 26, 2025], URL: <https://www.youtube.com/watch?v=nRazvayKcE> (Year: 2025).\*  
2025 G-Force DE-S All-Terrain Fat Tire Wide Cargo Electric Bike, G-Force Webpage[online], [Site Visit Mar. 20, 2025], URL: <https://g-forcebike.com/products/g-force-de-s-wide-cargo-e-bike?variant=52327052870003> (Year: 2025).\*

\* cited by examiner

*Primary Examiner* — Darlington Ly  
*Assistant Examiner* — Giang Hoang Tran  
(74) *Attorney, Agent, or Firm* — Birchwood IP

(57) **CLAIM**

The ornamental design for an electric bicycle, as shown and described.

**DESCRIPTION**

FIG. 1 is a top, front and right side perspective view of an electric bicycle showing my new design; FIG. 2 is a right side elevation view thereof; FIG. 3 is a left side elevation view thereof; FIG. 4 is a rear elevation view thereof; FIG. 5 is a front elevation view thereof; FIG. 6 is a top plan view thereof; and, FIG. 7 is a bottom plan view thereof.

**1 Claim, 7 Drawing Sheets**





FIG. 1



FIG. 2



FIG. 3



FIG. 4

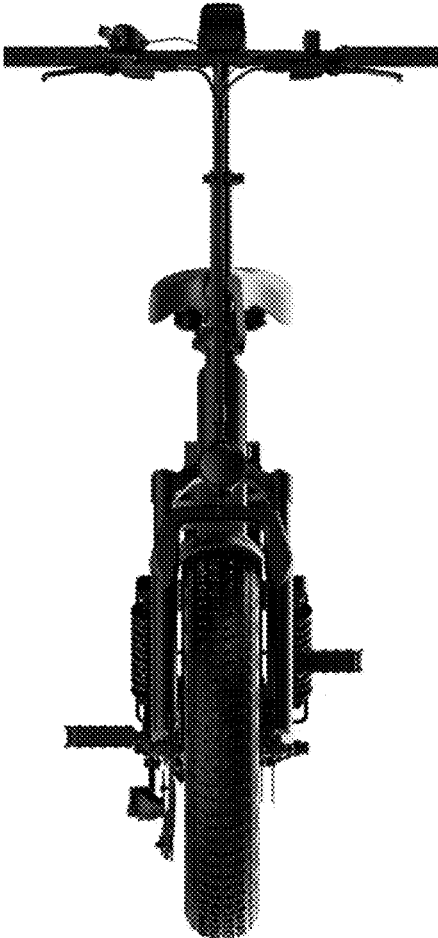

FIG. 5

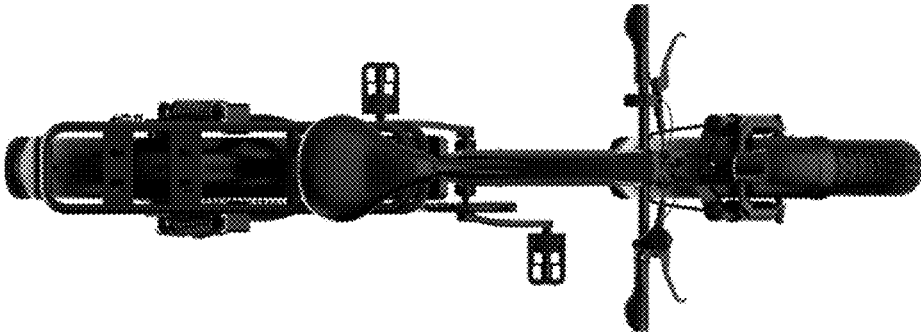

FIG. 6

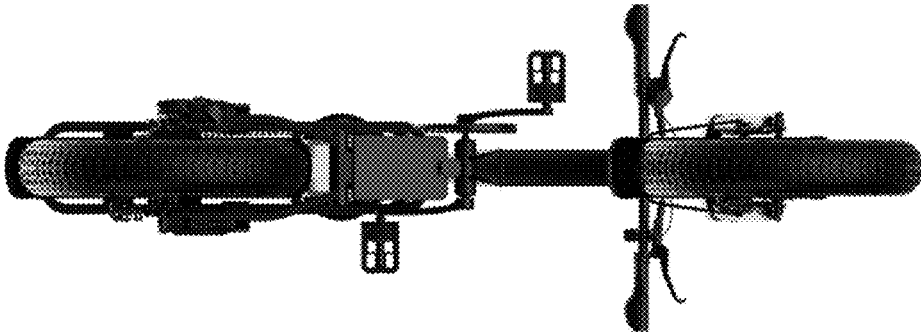

FIG. 7